

DESCRIPTION

The IP1521 is a dual output voltage series regulator which can provide up to 600mA of output current. The IP1521 consists of 1-fixed 3.3V and 1-fixed 1.8V regulators.

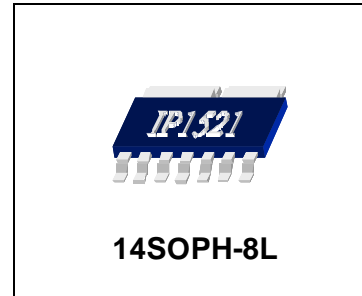

FEATURES

- 1-Fixed 3.3V Regulator with Internal NPN TR.
- 1-Fixed 1.8V Regulator with Internal NPN TR.
- Built-in TSD Circuit.
- Built-in Current Limit Circuit.
- Built-in ON/OFF Control Circuit.
- Built-in Over Voltage Protection Circuit.
- Output Trimmed to +/-3% Tolerance

ORDERING INFORMATION

Device	Package	Operating Temp
IP1521	14SOPH-8L	-35°C ~ +85°C

BLOCK DIAGRAM

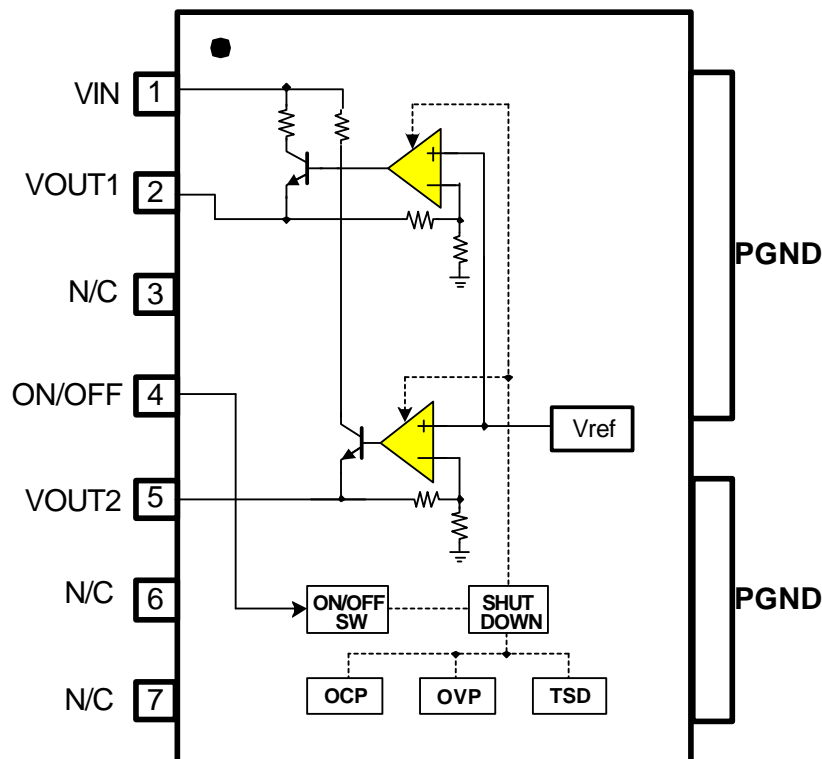

PIN CONNECTIONS

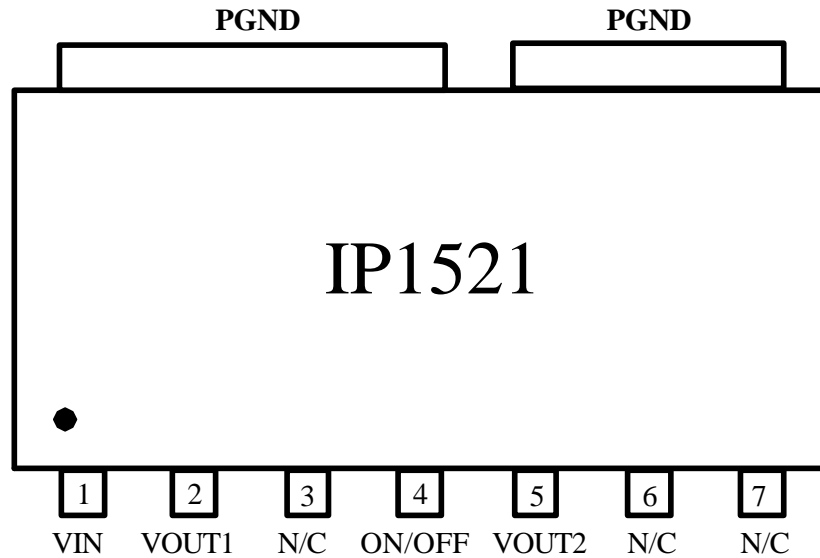

PIN DESCRIPTIONS

NO	SYMBOL	I/O	DESCRIPTION
1	VIN	I	Input Supply Voltage
2	VOUT1	O	Reg +3.3V Output
3	N/C	-	No Connection
4	ON/OFF	I	ON/OFF Control
5	VOUT2	O	Reg +1.8V Output
6	N/C	-	No Connection
7	N/C	-	No Connection
8	PGND	-	Power Ground

ABSOLUTE MAXIMUM RATINGS(TA=25°C)

CHARACTERISTICS	SYMBOL	VALUE	UNIT
Maximum supply voltage	VINmax	10	V
ON/OFF voltage	Vonoff	10	V
Power dissipation	Pd	3.5*	W
Operating temperature	Topr	-35 ~ +85	°C
Storage temperature	Tstr	-55 ~ +150	°C
Maximum output current	Iomax	700	mA

Note>

1. When mounted on 100mm X 100mm X 1mm PCB (Phenolic resin material).
2. Power dissipation reduces 28mW/°C for using above Ta=25°C
3. Do not exceed Pd and SOA.

POWER DISSIPATION CURVE

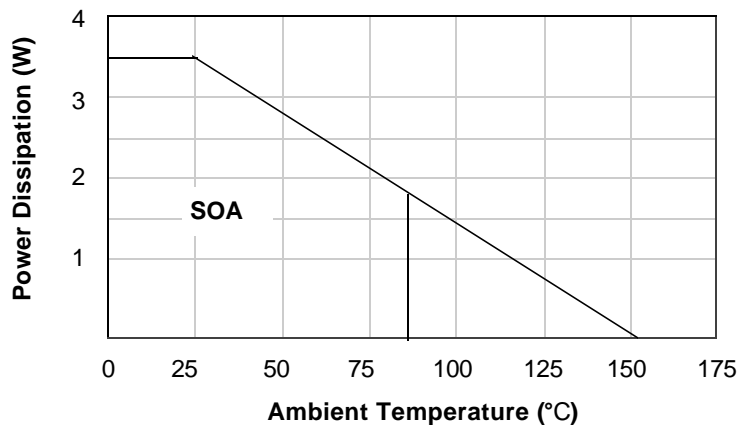

RECOMMENDED OPERATING CONDITIONS

CHARACTERISTICS	SYMBOL	VALUE	UNIT
Supply voltage	Vcc	4.5 ~ 6.0	V
Input voltage	Vin	4.5 ~ 6.0	V

ELECTRICAL CHARACTERISTICS

($V_{in}=5V$, $C_o=10\mu F$, $T_a = 25^\circ C$, unless otherwise specified.)

Characteristics	Symbol	Condition	Min.	Typ.	Max.	Units
Quiescent current	I _{cc}	V _{cc} =5V, No-Load	-	7	11	mA
OVP Detecting Voltage	V _{ovp}	V _{cc} =Variable	6.5	-	-	V
3.3V REGULATOR PART						
Output Voltage	V _{out1}	I _o =10mA	3.2	3.3	3.4	V
Line Regulation	dV _{line1}	V _{in} =4.5~6V, I _o =10mA	-	0.035	0.2	%
Load Regulation	dV _{load 1}	V _{in} =5V, 10mA < I _o < 500mA	-	0.4	0.8	%
Dropout voltage	V _{drop1}	I _o =500mA	-	1.1	1.3	V
Ripple rejection	RR1	F=120Hz, C _o =10μF Tantalum (V _{in} -V _{out})=3V, I _o =200mA	60	70	-	dB
Current limit ^{*Note}	I _{limit1}	V _{in} -V _{out} =2V	650	-	-	mA
Temperature stability	Temp1	-	-	0.5	-	%
Output noise voltage 1	V _{n1}	I _{out} =300mA	-	100	-	μV
1.8V REGULATOR PART						
Output Voltage	V _{out2}	I _o =10mA	1.746	1.8	1.854	V
Line Regulation	dV _{line2}	V _{in} =4.5~6V, I _o =10mA	-	0.035	0.2	%
Load Regulation	dV _{load2}	V _{in} =5V, 10mA < I _o < 300mA	-	0.4	0.8	%
Dropout voltage	V _{drop2}	I _o =300mA	-	1.7	2.1	V
Ripple rejection	RR2	F=120Hz, C _o =10μF Tantalum (V _{in} -V _{out})=3V, I _o =100mA	60	70	-	dB
Current limit ^{*Note}	I _{limit2}	V _{in} -V _{out} =3.5V	450	-	-	mA
Temperature stability	Temp2	-	-	0.5	-	%
Output noise voltage 2	V _{n2}	I _{out} =150mA	-	100	-	μV

ELECTRICAL CHARACTERISTICS (Continued)

(Vin= 5V, Co=10uF, Ta = 25°C, unless otherwise specified.)

ON/OFF CONTROL PART						
On voltage	Von	Vout=Enabled	-	-	0.8	V
Off voltage	Voff	Vout=Disabled	2.0	-	-	V

* Note

Don't exceed following current limit.
(Iout1 : 650 mA, Iout2 : 450 mA)

APPLICATION SUMMARY

- ON / OFF

When you want to control output of the IP1521, use pin #4 as follows

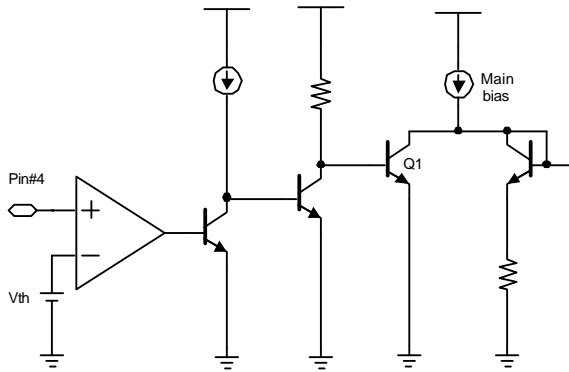

on/off function

Pin#4	IP1521
HIGH	off
LOW	on

As shown in figure Pin#4 is positive input of the comparator, and the other Input is threshold voltage. If the voltage of the pin#4 rises above threshold voltage, then TR Q1 will be saturated and the main bias current will be shut down.

TYPICAL APPLICATION CIRCUIT

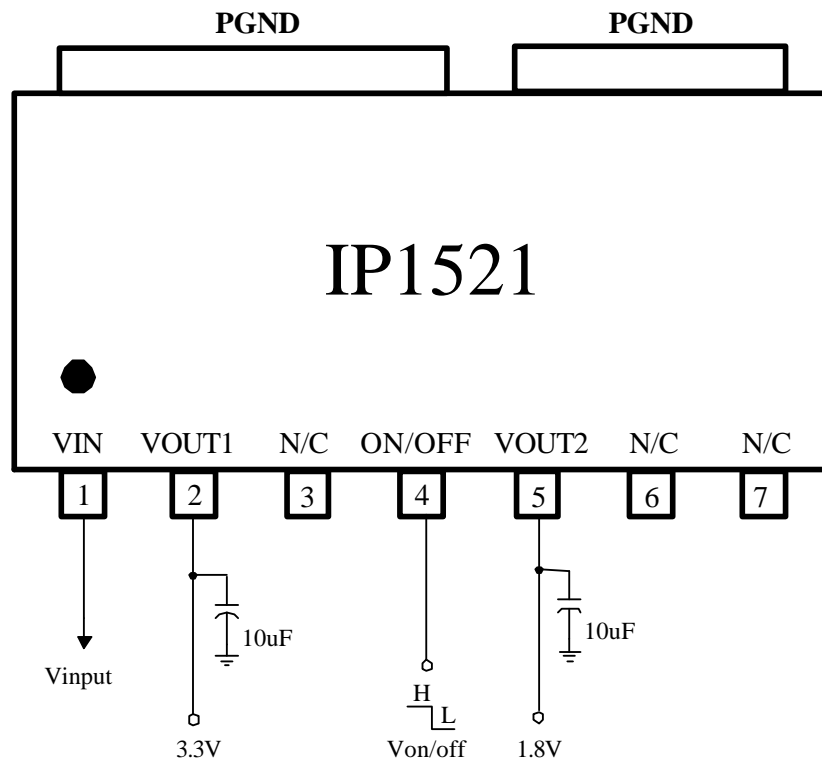

INTERNAL CIRCUIT

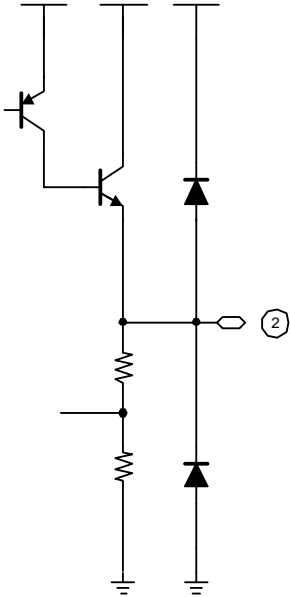
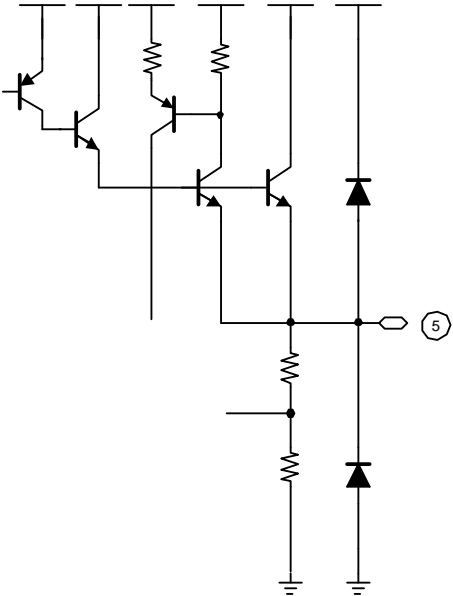
Pin no	Pin name	Internal circuit
2	Regulator output1	
5	Regulator Output2	

INTERNAL CIRCUIT (Continued)

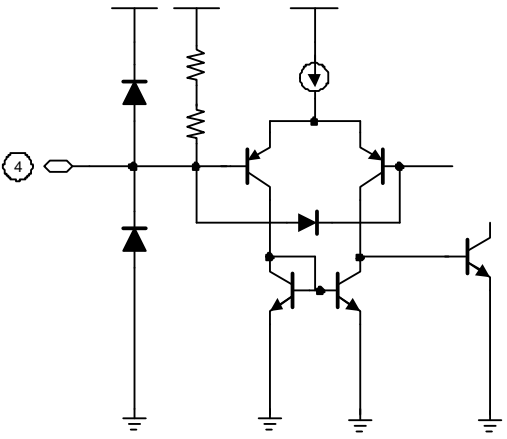
Pin no	Pin name	Internal circuit
4	ON / OFF	

VCC vs ICC

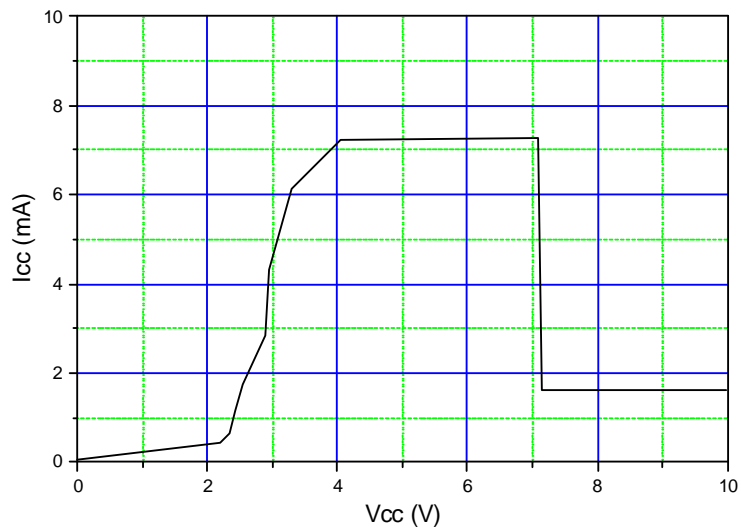

VREF TEMPERATURE STABILITY

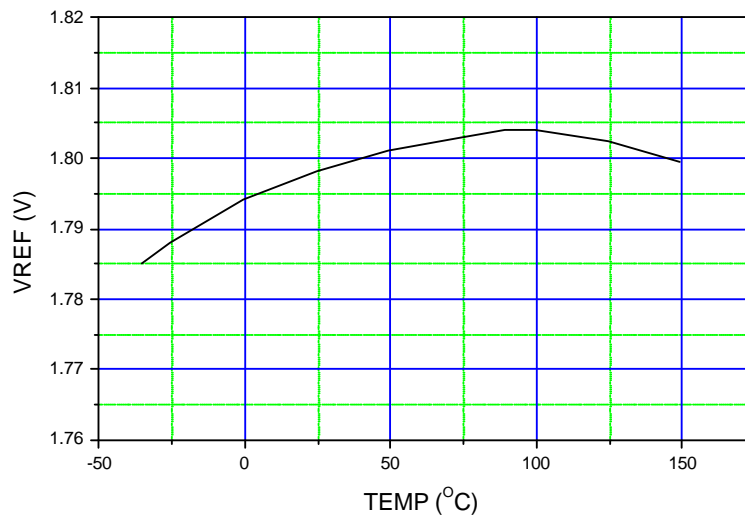

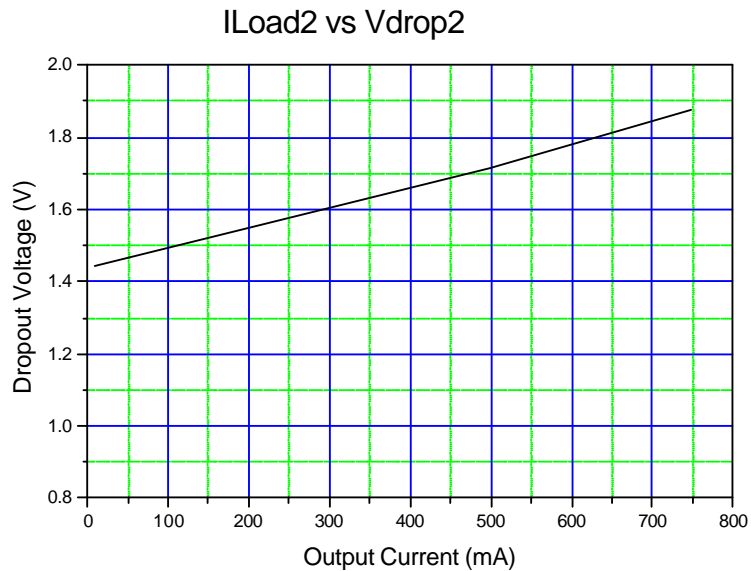
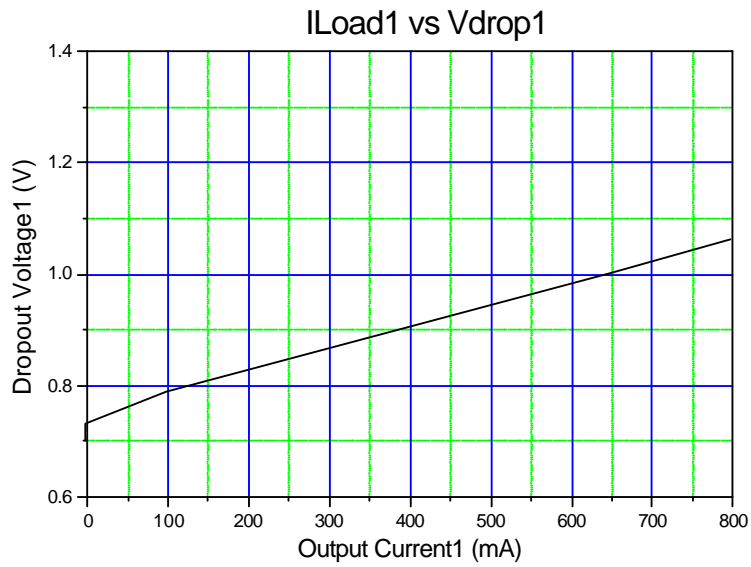

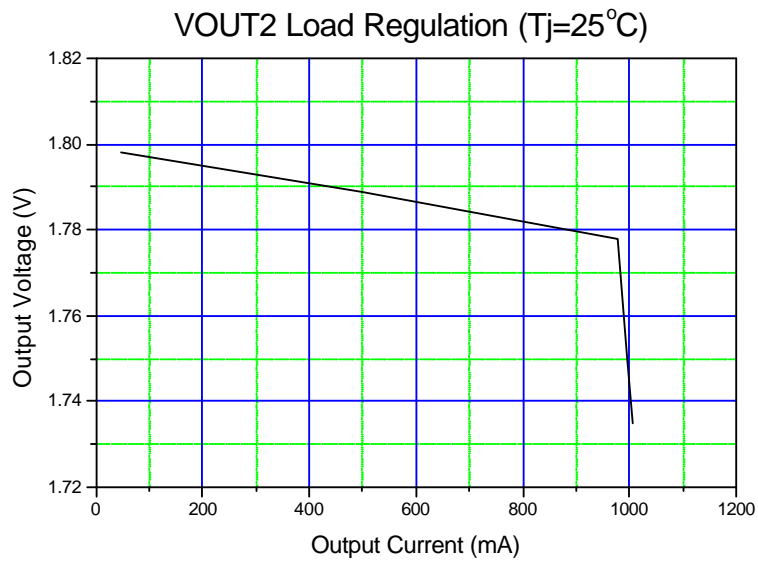
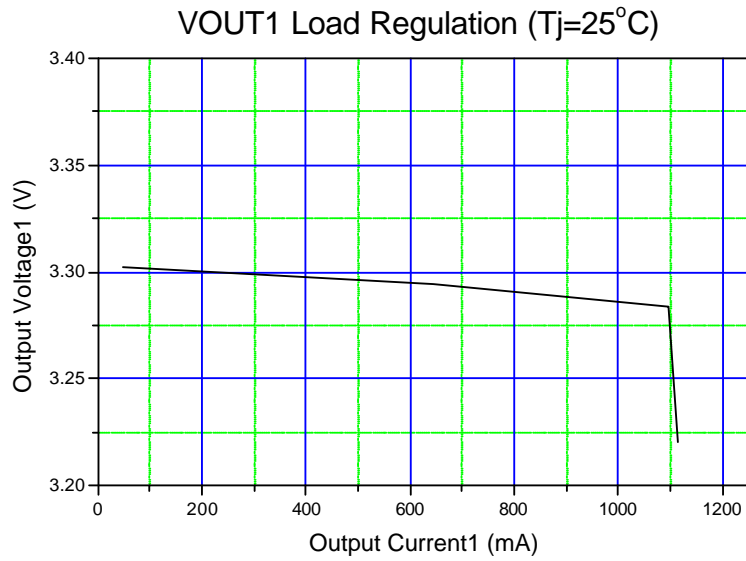

VOUT1 Load Transient Response

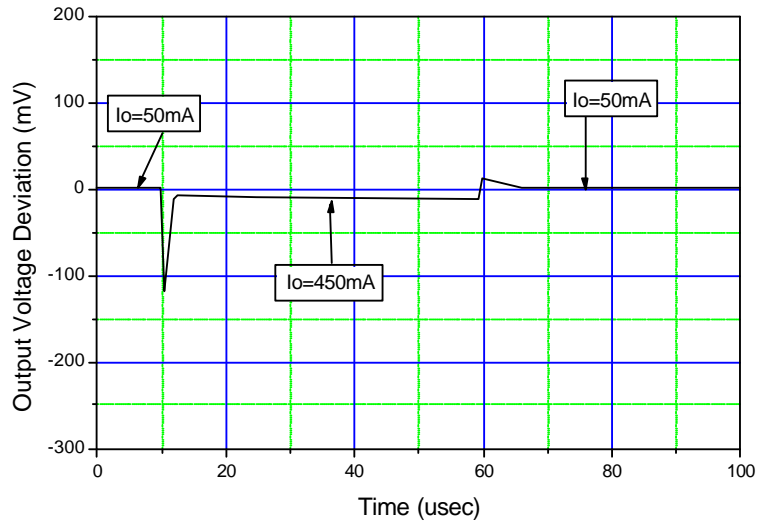

VOUT2 Load Transient Response

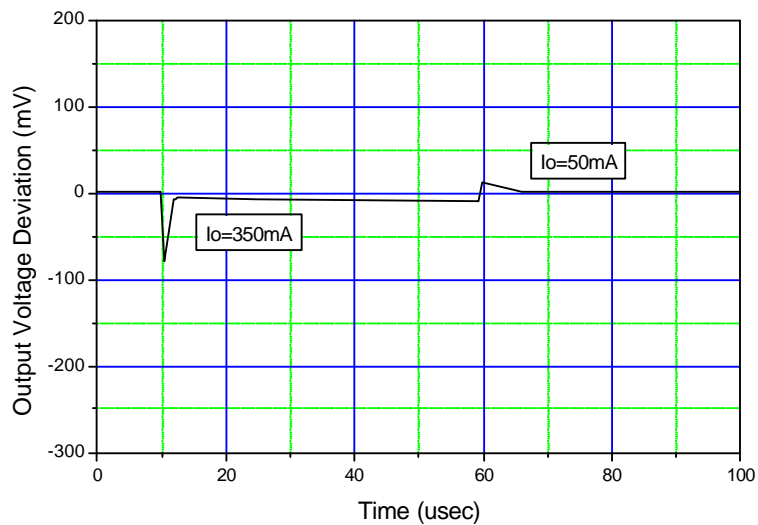

PACKAGE DIMENSION

14SOPH-8L

