

* The Main Differences of IP103 and IP103H are **V_{icm}**(Input Common Mode Voltage Range) and **V_{op}**(Operating Voltage)

DESCRIPTION

The IP103H is designed to be used in battery chargers with a constant voltage and a constant current control.

This device is a monolithic IC that includes one independent op-amp and other op-amp for which the non inverting input is wired to a 2.5V fixed Voltage reference.

Integrating the reference and op-amps creates a solution for low cost charging applications.

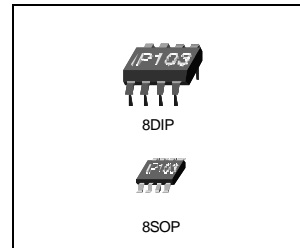

FEATURES

Operational Amplifiers

- Low Supply Current : 200uA/amp
- Medium Speed : 1.5MHz
- Low Level Output Voltage Close to VEE : 0.1V Typ.
- **Wide Power Supply Range; 3.6~28V**

Adjustable Shunt Regulator

- Fixed Output Voltage Reference 2.5V
- Sink Current Capability : 0.5 to 150mA
- 1% Voltage Precision
- Latch-up Immunity

ORDERING INFORMATION

Device	Package	Operating Temp
IP103H	8DIP	-40°C ~ +105°C
I103H	8SOP	

BLOCK DIAGRAM

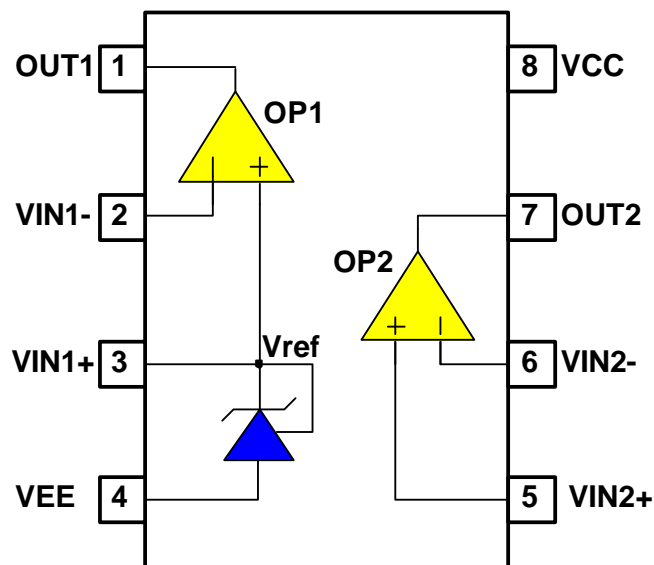

PIN CONNECTIONS

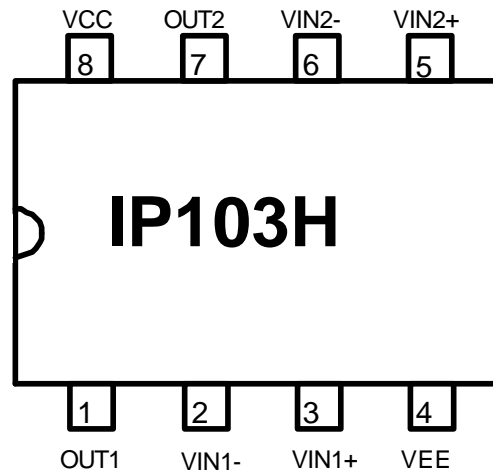

PIN DESCRIPTIONS

NO	SYMBOL	I/O	DESCRIPTION
1	OUT1	O	OP-Amp 1 Output
2	VIN1-	I	OP-Amp 1 Inverting Input
3	VIN1+	I	OP-Amp 1 Non-Inverting Input
4	VEE	-	Negative Supply Voltage
5	VIN2+	I	OP-Amp 2 Non-Inverting Input
6	VIN2-	I	OP-Amp 2 Inverting Input
7	OUT2	O	OP-Amp 2 Output
8	VCC	-	Positive Supply Voltage

ABSOLUTE MAXIMUM RATINGS

PARAMETER	SYMBOL	VALUE	UNIT
Supply Voltage	V _{ccmax}	28	V
Operating Temperature	T _{opr}	-40 ~ +105	°C
Storage temperature	T _{stg}	-65 ~ 150	°C

ELECTRICAL CHARACTERISTICS

T_a = 25°C, V_{CC} = 5V, V_{EE} = GND (unless otherwise specified.)

TOTAL SUPPLY VOLTAGE SECTION						
CHARACTERISTICS	SYMBOL	CONDITIONS	MIN	TYP	MAX	UNIT
Total Supply Current	I _{cc}	V _{ee} = 0V, No Load		0.8	1.5	mA
Operational Amplifiers						
Input Offset Voltage	V _{io}		-	1	4.5	mV
Input Bias Current	I _{ib}		-	50	150	nA
Large Signal Voltage Gain	A _{vd}	V _{cc} =15V, V _o =5~10V, R _{load} =10K	60	100	-	dB
Supply Voltage Rejection Ratio	SVRR	V _{cc} = 5V to 15V	65	100	-	dB
Input Common Mode Voltage Range	V _{icm}	-	0	-	V _{cc} -1.8V	V
Common Mode Rejection Ratio	CMRR	V _{cc} =15V	70	90	-	dB
Output Source Current	I _{source}	V _o =2.5V, V _{id} =+1V	3	6	-	mA
Output Sink Current	I _{sink}	V _o =2.5V, V _{id} =-1V	3	6	-	mA
Phase Margin	PM	R _{load} =10K,C _{load} =100pF	-	55	-	Degree
Output Voltage High	V _{oh}	V _{cc} =15V, R _{load} =10K	12	13	-	V
Output Voltage Low	V _{ol}	R _{load} =10K	-	100	250	mV
Slew Rate	SR	V _i =10V, V _{cc} =12V, R _{load} =10K,C _{load} =100pF	-	0.75	-	V/us
Gain Bandwidth	GB	R _{load} =10K,C _{load} =100pF, f=100kHz	-	1.5	-	MHz
Total Harmonic Distortion	THD		-	0.05	-	%

ELECTRICAL CHARACTERISTICS

Ta = 25°C, VCC = 5V, VEE=GND (unless otherwise specified.)

Adjustable Shunt Regulator						
CHARACTERISTICS	SYMBOL	CONDITIONS	MIN	TYP	MAX	UNIT
Recommended Cathode Current	I _k		0.5		100	mA
Reference Input Voltage	V _{ref}		2.475	2.5	2.525	V
Reference Input Voltage Deviation	dV _{ref}	V _{ka} =V _{ref} , I _k =10mA -40°C < Ta < 105°C		7	30	mV
Load Regulation	R _{load}	I _k =1mA~10mA		3	10	mV
Minimum Cathode Current for Regulation	I _{min}			0.2	0.5	mA

TYPICAL APPLICATION

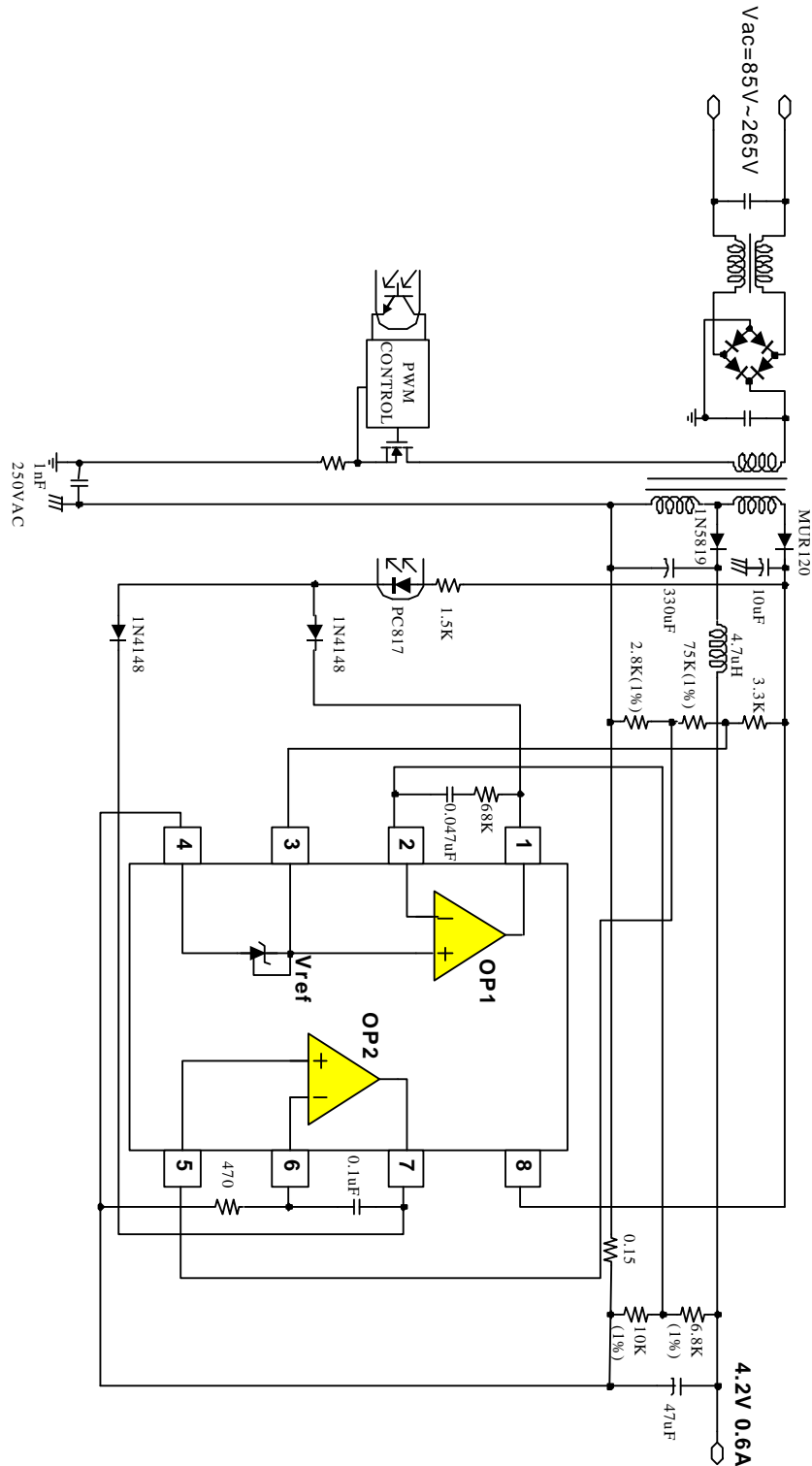

ELECTRICAL DIAGRAMS

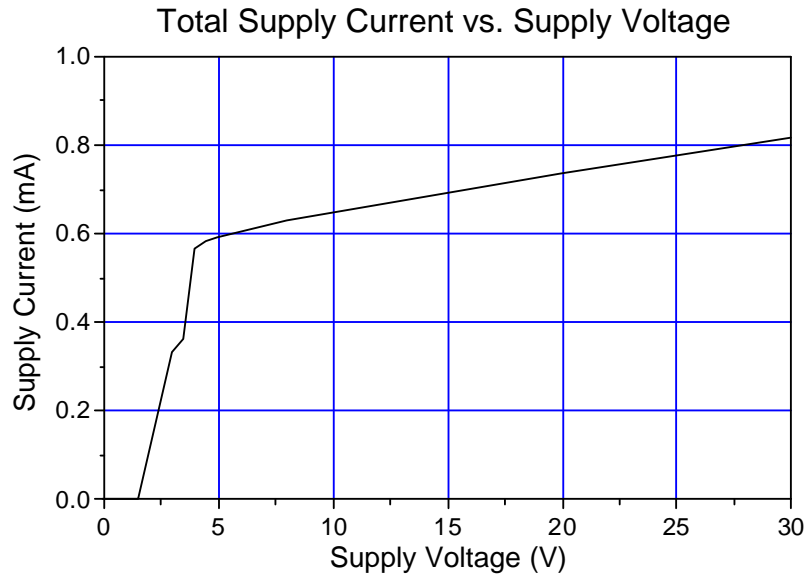

Fig.1 : Toatal Supply Current vs. Supply Voltage

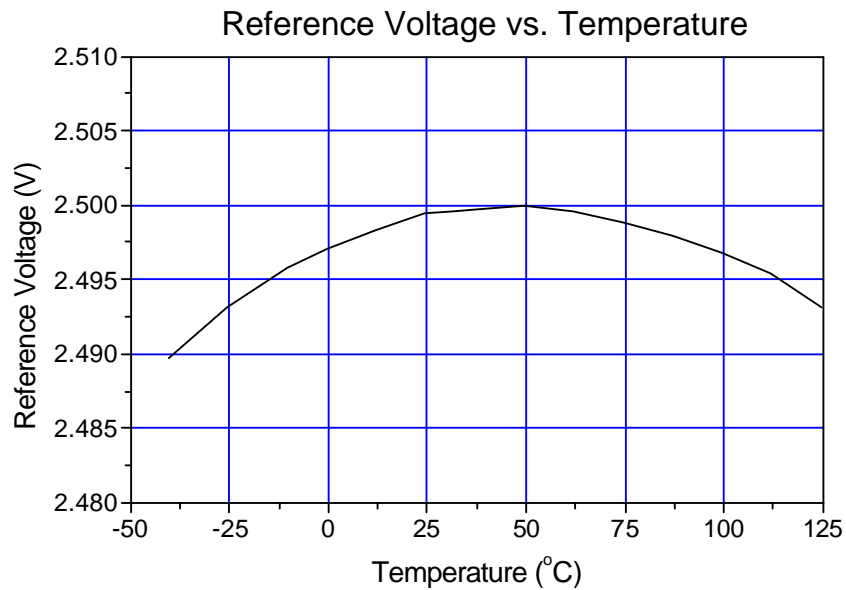

Fig.2 : Reference Voltage vs. Temperature

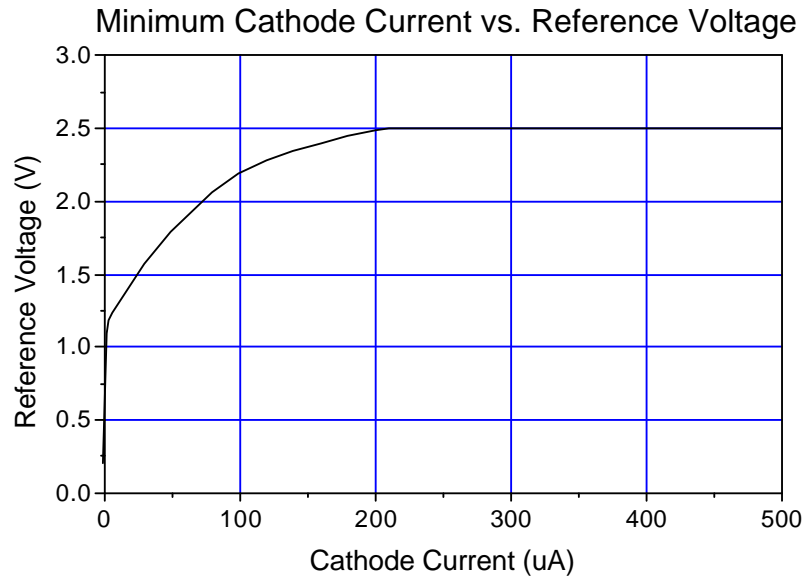

Fig.3 : Minimum Cathode Current vs. Reference Voltage

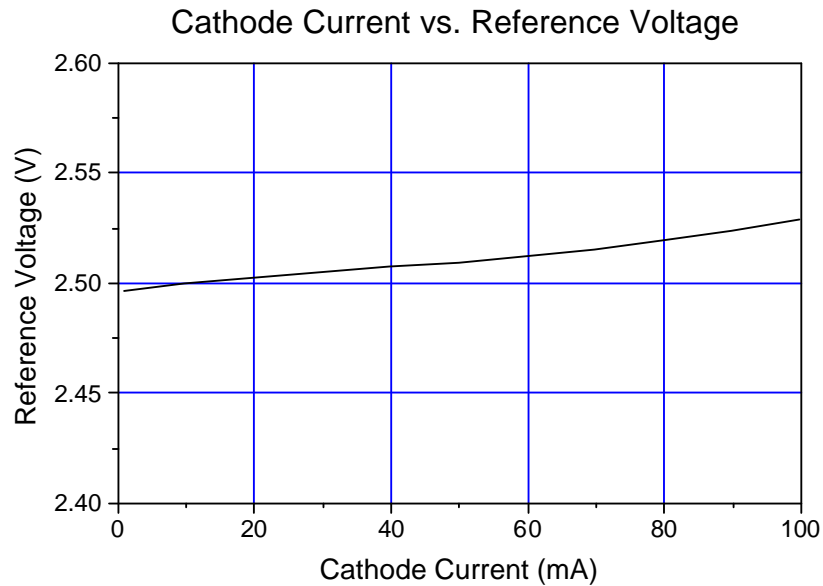

Fig.4 : Cathode Current VS. Reference Voltage

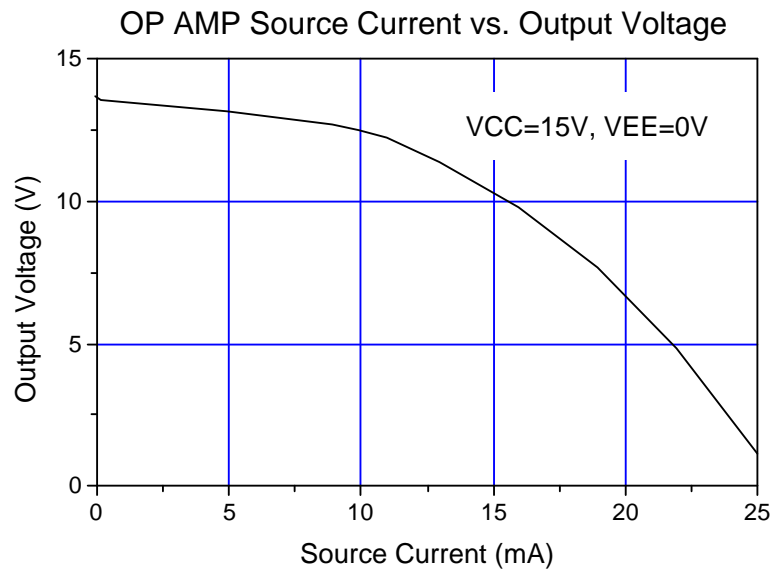

Fig.5 : OP AMP Source Current vs. Output Voltage

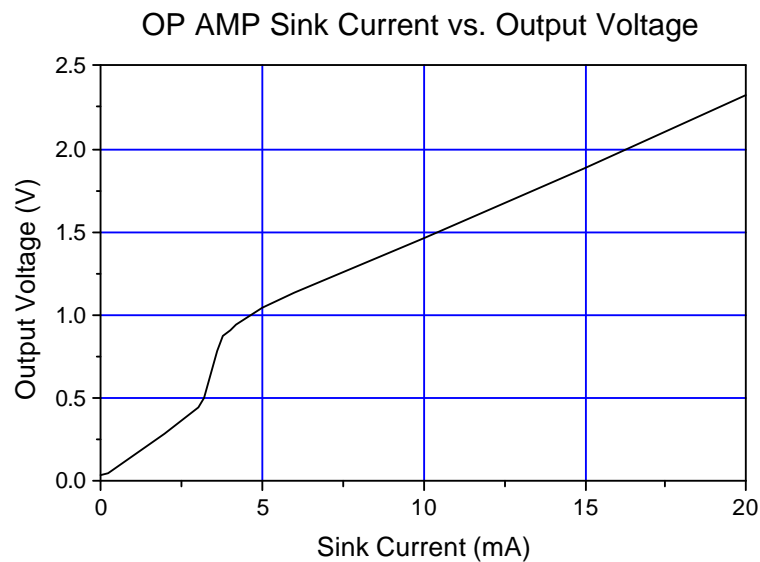

Fig.6 : OP AMP Sink Current vs. Output Voltage

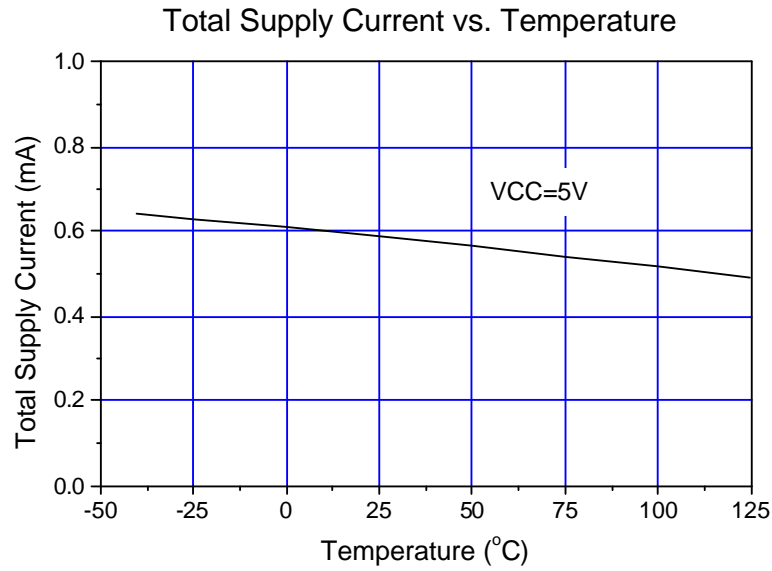

Fig.7 : Total Supply Current vs. Temperature

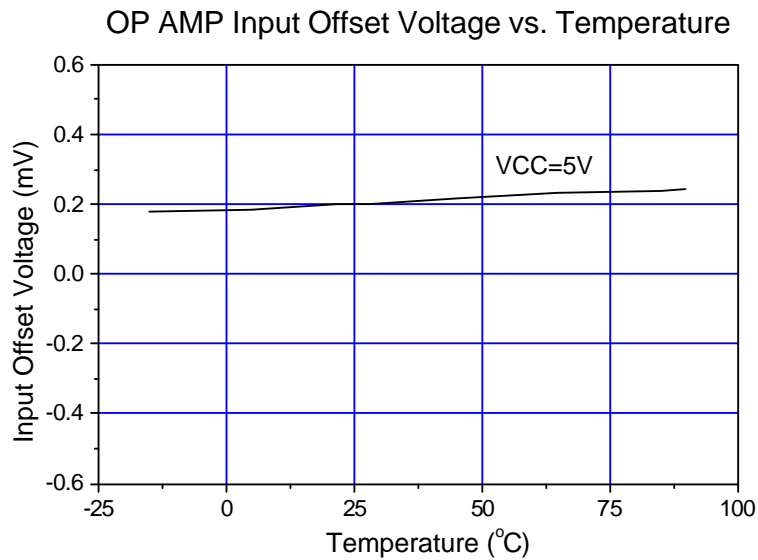

Fig.8 : OP AMP Input Offset Voltage vs. Temperature

PACKAGE DIMENSION

8-DIP

