

FEATURES

1. This specification shall be applied to photocoupler. Model No. 4N25 / 4N26 as an option.

2. Applicable Models (Business dealing name)

* Response time

(t_r : TYP. $3\mu\text{s}$ at $V_{CE} = 10\text{V}$, $I_C = 2\text{mA}$, $R_L = 100\Omega$)

* Current transfer ratio

(CTR : MIN. 20% at $I_F = 10\text{mA}$, $V_{CE} = 10\text{V}$)

* Input-output isolation voltage

4N25 series : $V_{iso} = 2,500\text{Vrms}$

4N26 series : $V_{iso} = 1,500\text{Vrms}$

* Dual-in-line package :

4N25-V, 4N26-V

* Wide lead spacing package :

4N25M-V, 4N26M-V

* Surface mounting package :

4N25S-V, 4N26S-V

* Tape and reel packaging :

4N25S-TA1-V, 4N26S-TA1-V

* Creepage distance > 8.0 mm

* Clearance > 8.0 mm

3. Safety certification list

* UL approved (No. E113898)

* TUV approved (No. R9653630)

* CSA approved (No. CA91533-1)

* FIMKO approved (No. 193422-01)

* NEMKO approved (No. P96103013)

* DEMKO approved (No. 303985)

* SEMKO approved (No. 9646047 / 01-30)

* VDE approved (No. 094722)

FEATURES

4. The relevant models are the models Approved by VDE according to DIN VDE 0884:1992-06

Approved Model No.: 4N25 / 4N256 / 4N25M / 4N26M / 4N25S / 4N26S ;
4N25S-TA1 / 4N256S-TA1

VDE approved No.: 094722

(According to the specification DIN VDE 0884:1992-06)

- * Operating isolation voltage V_{IORM} : 420V (Peak)
- * Transient voltage V_{TR} : 6000V (Peak)
- * Pollution : 2 (According to VDE 0110-1 : 1997-04)
- * Clearances distance (Between input and output) : 7.0mm (MIN.)
- * Creepage distance (Between input and output) : 7.0mm (MIN.)
- * Isolation thickness between input and output : 0.4mm (MIN.)
- * Safety limit values Current (Isi) : 400mA (Diode side)
 Power (Psi) : 700mW (Phototransistor side)
 Temperature(Tsi) : 175°C

In order to keep safety electric isolation of photocoupler, please set the protective circuit to keep within safety limit values when the actual application equipment troubled.

- * Indication of VDE 0884 approval prints "  " on sleeve package.

OUTLINE DIMENSIONS

4N25 / 4N26:

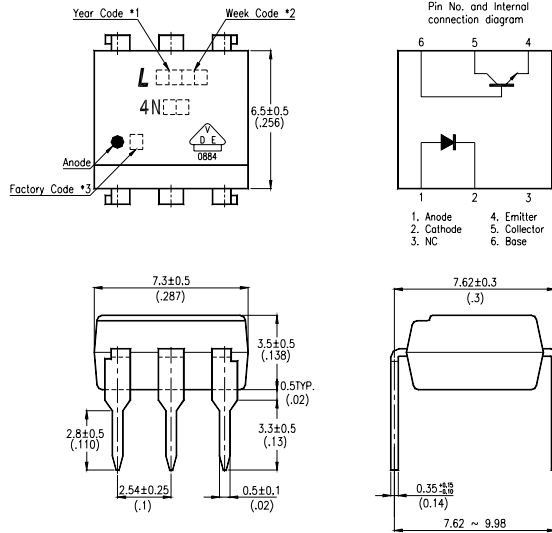

4N25M / 4N26M:

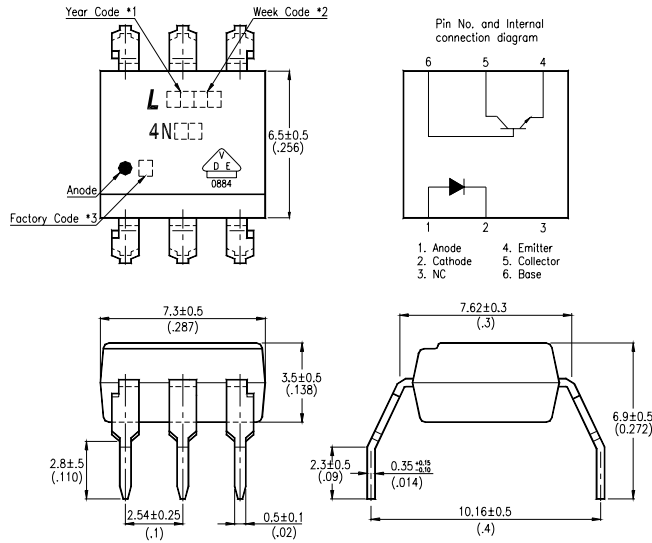

- *1. Year date code.
- *2. 2-digit work week.
- *3. Factory identification mark shall be marked (Z : Taiwan, Y : Thailand).

OUTLINE DIMENSIONS

4N25S / 4N26S :

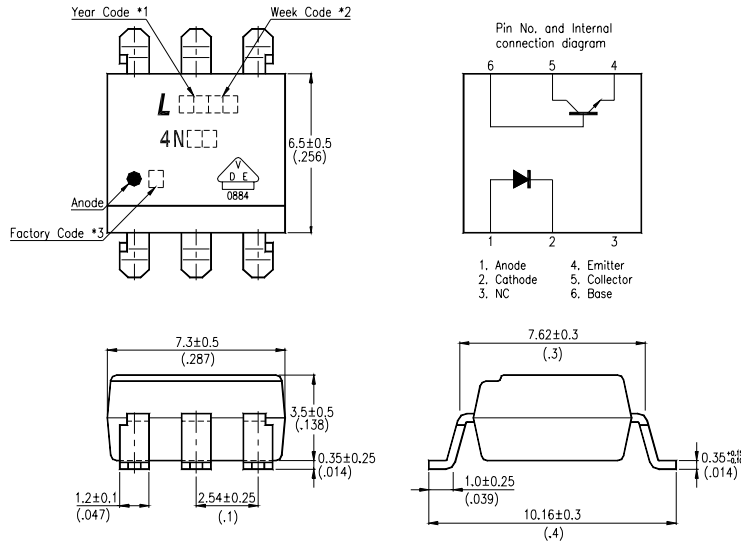

- *1. Year date code.
- *2. 2-digit work week.
- *3. Factory identification mark shall be marked (Z : Taiwan, Y : Thailand).

TAPING DIMENSIONS

4N25S-TA1 , 4N26S-TA1 :

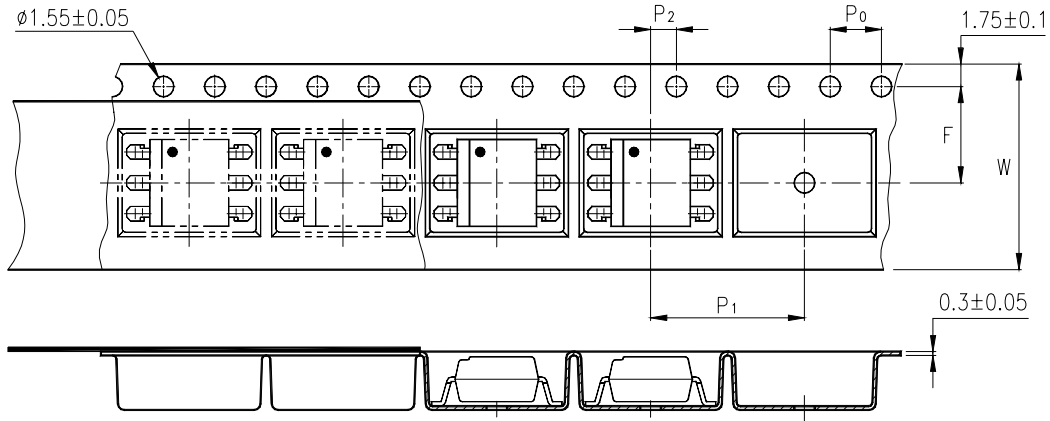

Description	Symbol	Dimensions in mm (inches)
Tape wide	W	16 ± 0.3 (.63)
Pitch of sprocket holes	P ₀	4 ± 0.1 (.15)
Distance of compartment	F	7.5 ± 0.1 (.295)
Distance of compartment to compartment	P ₂	2 ± 0.1 (.079)
Distance of compartment to compartment	P ₁	12 ± 0.1 (.472)

ABSOLUTE MAXIMUM RATING

(Ta = 25°C)

PARAMETER		SYMBOL	RATING	UNIT
INPUT	Forward Current	I _F	80	mA
	Reverse Voltage	V _R	6	V
	Power Dissipation	P	150	mW
OUTPUT	Collector - Emitter Voltage	V _{CEO}	30	V
	Emitter - Collector Voltage	V _{ECO}	7	V
	Collector - Base Voltage	V _{CBO}	70	V
	Collector Current	I _C	100	mA
	Collector Power Dissipation	P _C	150	mW
Total Power Dissipation		P _{tot}	250	mW
*1	Isolation Voltage	V _{iso}	5,000	V _{rms}
Operating Temperature		T _{opr}	-55 ~ +100	°C
Storage Temperature		T _{stg}	-55 ~ +150	°C
*2	Soldering Temperature	T _{sol}	260	°C

*1. AC For 1 Minute, R.H. = 40 ~ 60%

Isolation voltage shall be measured using the following method.

- (1) Short between anode and cathode on the primary side and between collector, emitter and base on the secondary side.
- (2) The isolation voltage tester with zero-cross circuit shall be used.
- (3) The waveform of applied voltage shall be a sine wave.

*2. For 10 Seconds

ELECTRICAL - OPTICAL CHARACTERISTICS

(Ta = 25°C)

PARAMETER		SYMBOL	MIN.	TYP.	MAX.	UNIT	CONDITIONS
INPUT	Forward Voltage	V _F	—	1.2	1.5	V	I _F =10mA
	Reverse Current	I _R	—	—	10	μA	V _R =4V
	Terminal Capacitance	C _t	—	50	—	pF	V=0, f=1KHz
OUTPUT	Collector Dark Current	I _{CEO}	—	—	50	nA	V _{CE} =10V, I _F =0
	Collector-Emitter Breakdown Voltage	BV _{CEO}	30	—	—	V	I _C =0.1mA I _F =0
	Emitter-Collector Breakdown Voltage	BV _{ECO}	7	—	—	V	I _E =10μA I _F =0
	Collector-Base Breakdown Voltage	BV _{CBO}	70	—	—	V	I _C =0.1mA I _F =0
TRANSFER CHARACTERISTICS	Collector Current	I _C	2	—	—	mA	I _F =10mA V _{CE} =10V
	* Current Transfer Ratio	CTR	20	—	—	%	
	Collector-Emitter Saturation Voltage	V _{CE(sat)}	—	0.1	0.5	V	I _F =50mA I _C =2mA
	Isolation Resistance	R _{iso}	5×10 ¹⁰	1×10 ¹¹	—	Ω	DC500V 40 ~ 60% R.H.
	Floating Capacitance	C _f	—	1	—	pF	V=0, f=1MHz
	Response Time (Rise)	t _r	—	3	—	μs	V _{CE} =10V, I _C =2mA R _L =100Ω
	Response Time (Fall)	t _f	—	3	—	μs	

$$* \text{ CTR} = \frac{I_C}{I_F} \times 100\%$$

ISOLATION SPECIFICATION ACCORDING TO VDE 0884

Parameter	Symbol	Conditions	Rating	Unit	Remark	
Class of environmental test	-	DIN IEC68	55/100/21	-		
Pollution	-	DIN VDE0110	2	-		
Maximum Operating Isolation Voltage	V_{IORM}	-	420	V_{PEAK}	Refer to the Diagram 1, 2	
Partial Discharge Test Voltage (Between Input and Output)	Diagram 1	V_{pr}	$t_p=60s, q_c<5pC$	630		V_{PEAK}
	Diagram 2		$t_p=1s, q_c<5pC$	788		V_{PEAK}
Maximum Over-voltage	$V_{INITIAL}$	$t_{NI} = 10s$	6000	V_{PEAK}		
Safety Maximum Ratings						
1) Case Temperature	T_{si}	$I_F = 0, P_c = 0$	175	$^{\circ}C$	Refer to the Figure 1, 3	
2) Input Current	I_{si}	$P_c=0$	400	mA		
3) Electric Power (Output or Total Power Issipation)	P_{si}	-	700	mW		
Isolation Resistance (Test Voltage Between Input and Output : DC500V)	R_{ISO}	$T_a=T_{si}$	MIN. 10^9	Ω		
		$T_a=T_{opr}(MAX.)$	MIN. 10^{11}			
		$T_a=25^{\circ}C$	MIN. 10^{12}			

Precautions in performing isolation test

* Partial discharge test methods shall be the ones according to the specifications of VDE 0884:1992-06

* Please don't carry out isolation test (V_{iso}) over $V_{INITIAL}$,This product deteriorates isolation characteristics by partial discharge due to applying high voltage (ex. $V_{INITIAL}$). And there is possibility that this product occurs partial discharge in operating isolation voltage (V_{IORM})

PARTIAL DISCHARGE TEST METHOD

Method (A) for type testing and random testing.

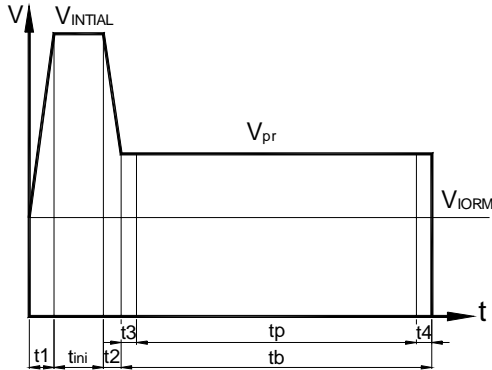

t_1, t_2 = 1 to 10s
 t_3, t_4 = 1s
 t_p (Partial Discharge Measuring Time) = 60s
 t_b = 62s
 t_{ini} = 10s

Method (B) for routine testing.

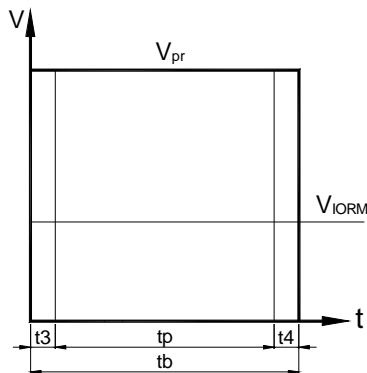

t_3, t_4 = 0.1s
 t_p (Partial Discharge Measuring Time) = 1s
 t_b = 1.2s

The partial discharge level shall not exceed 5 pC during the partial discharge measuring time interval t_p under the test conditions shown above.

CHARACTERISTICS CURVES

Fig. 1 Forward Current vs. Ambient Temperature

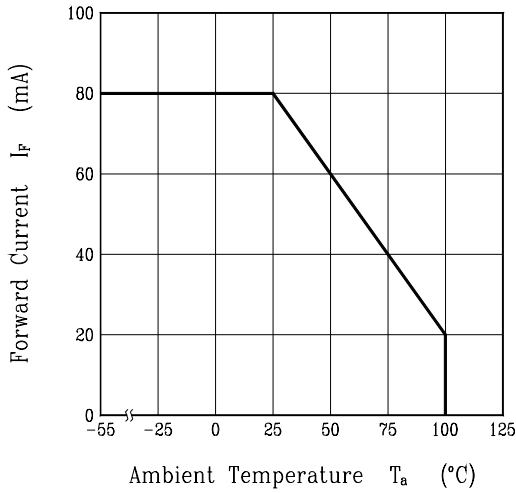

Fig. 2 Diode Power Dissipation vs. Ambient Temperature

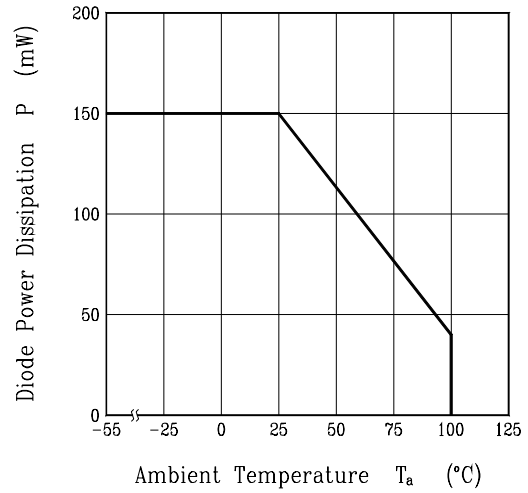

Fig. 3 Collector Power Dissipation vs. Ambient Temperature

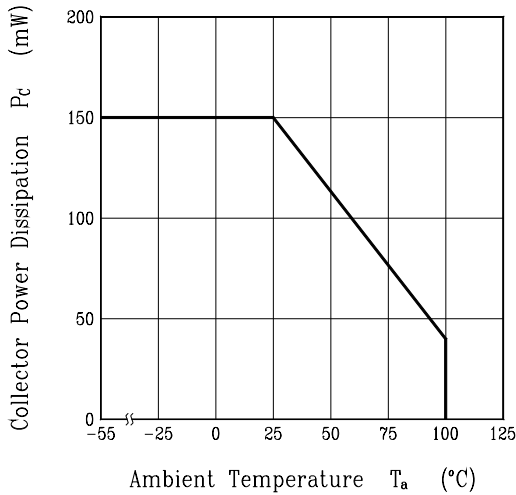
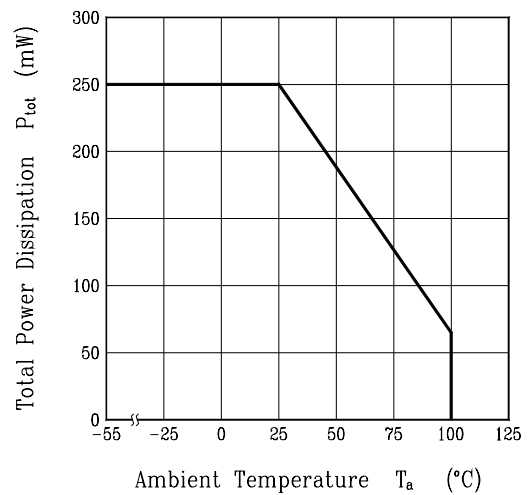
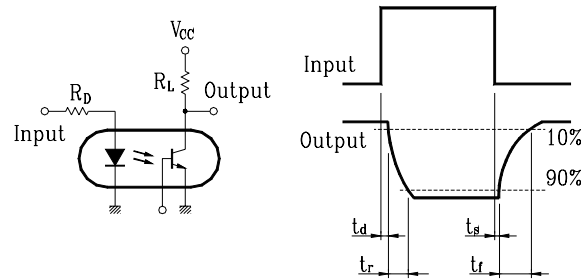

Fig. 4 Total Power Dissipation vs. Ambient Temperature



TEST CIRCUITS

Test Circuit for Response Time



Test Circuit for Frequency Response

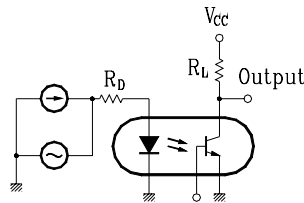

TEMPERATURE PROFILE OF SOLDERING REFLOW

(1) One time soldering reflow is recommended within the condition of temperature and time profile shown below.

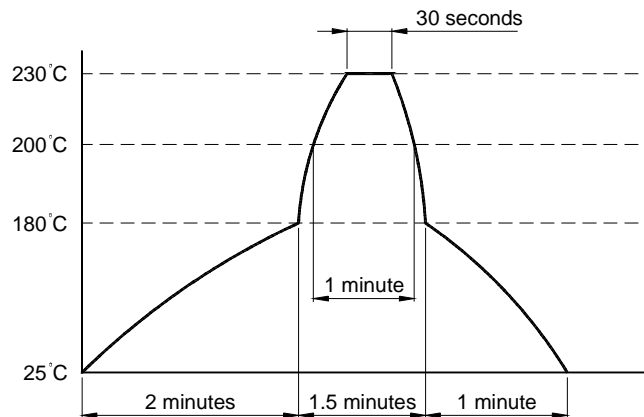

(2) When using another soldering method such as infrared ray lamp, the temperature may rise partially in the mold of the device.
Keep the temperature on the package of the device within the condition of above (1)

RECOMMENDED FOOT PRINT PATTERNS (MOUNT PAD)

Unit : mm

