

**FEATURES**

1. This specification shall be applied to photocoupler. Model No. MOC3063 as an option.

2. Applicable Models (Business dealing name)

\* Dual-in-line package :

MOC3063-V : 1-channel type

\* Wide lead spacing package :

MOC3063M-V : 1-channel type

\* Surface mounting package :

MOC3063S-V : 1-channel type

\* Tape and reel packaging :

MOC3063S TA1-V

3. The relevant models are the models Approved by VDE according to DIN VDE 0884:1992-06

Approved Model No.: MOC3063 / MOC3063M / MOC3063S /

VDE approved No.: 094722

(According to the specification DIN VDE 0884:1992-06)

\* Operating isolation voltage  $V_{IORM}$  : 850V (Peak)

\* Transient voltage  $V_{TR}$  : 6000V (Peak)

\* Pollution : 2 (According to VDE 0110-1 : 1997-04)

\* Clearances distance (Between input and output) : 7.0mm (MIN.)

\* Creepage distance (Between input and output) : 7.0mm (MIN.)

\* Isolation thickness between input and output : 0.4mm (MIN.)

\* Safety limit values Current (Isi) : 400mA (Diode side)

Power (Psi) : 700mW (Phototransistor side)

Temperature(Tsi) : 175°C

In order to keep safety electric isolation of photocoupler, please set the protective circuit to keep within safety limit values when the actual application equipment troubled.

\* Indication of VDE 0884 approval prints "  " on sleeve package.

## OUTLINE DIMENSIONS

### Dual-in-line package :

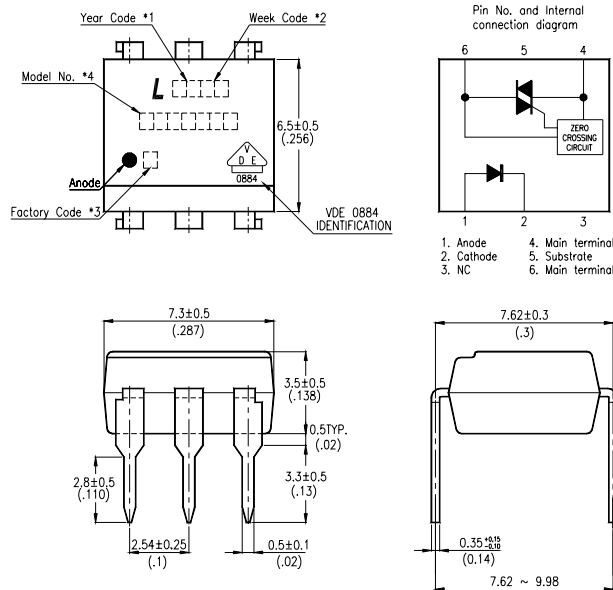

### Wide lead spacing package:

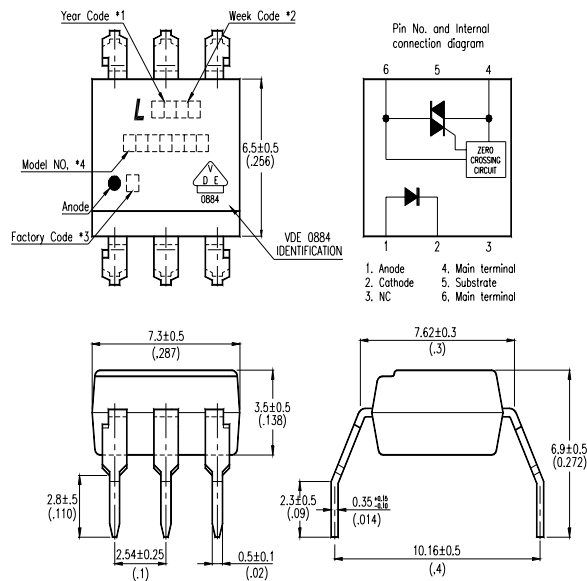

- \*1. Year date code.
- \*2. 2-digit work week.
- \*3. Factory identification mark shall be marked (Z : Taiwan, Y : Thailand, X : China).
- \*4. Model No.: MOC3063

## OUTLINE DIMENSIONS

Surface mounting package :

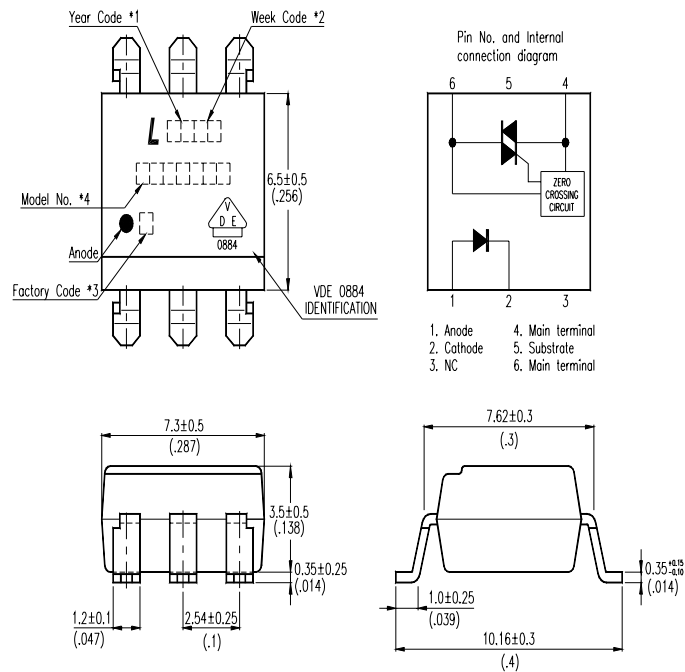

- \*1. Year date code.
- \*2. 2-digit work week.
- \*3. Factory identification mark shall be marked (Z : Taiwan, Y : Thailand, X : China).
- \*4. Model MOC3063

## TAPING DIMENSIONS

**Tape and reel package ( TYPE I ):  
MOC3063S-TA1**

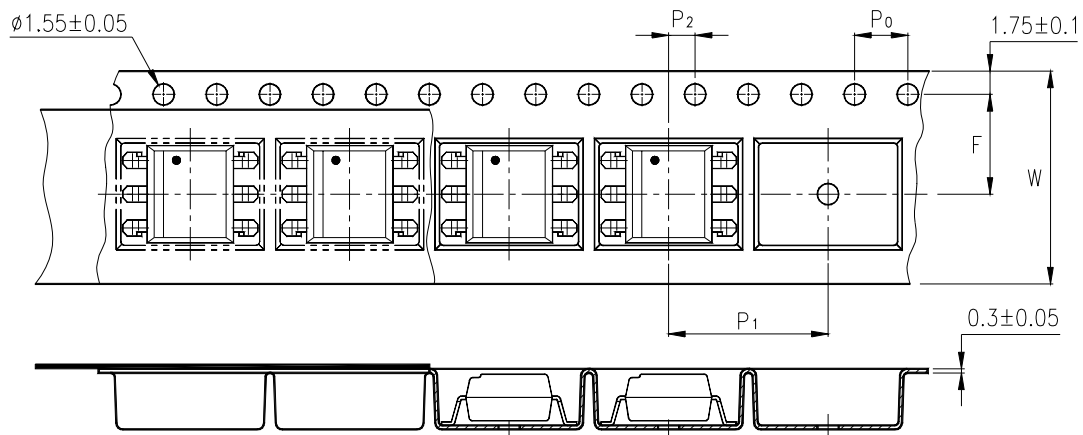

Description	Symbol	Dimensions in mm ( inches )
Tape wide	W	$16 \pm 0.3$ ( .63 )
Pitch of sprocket holes	$P_0$	$4 \pm 0.1$ ( .15 )
Distance of compartment	F	$7.5 \pm 0.1$ ( .295 )
	$P_2$	$2 \pm 0.1$ ( .079 )
Distance of compartment to compartment	$P_1$	$12 \pm 0.1$ ( .472 )

**ABSOLUTE MAXIMUM RATING**

( Ta = 25°C )

PARAMETER		SYMBOL	RATING	UNIT
INPUT	Forward Current	I <sub>F</sub>	50	mA
	Reverse Voltage	V <sub>R</sub>	6	V
	Power Dissipation	P <sub>D</sub>	120	mW
OUTPUT	Off-State Output Terminal Voltage	V <sub>DRM</sub>	600	V
	Peak Repetitive Surge Current ( PW=100μs, 120pps )	I <sub>TSM</sub>	1	A
	Collector Power Dissipation	P <sub>C</sub>	150	mW
Total Power Dissipation		P <sub>tot</sub>	250	mW
*1	Isolation Voltage	V <sub>iso</sub>	5,000	Vrms
Ambient Operating Temperature Range		T <sub>A</sub>	-40 ~ +100	°C
Storage Temperature Range		T <sub>stg</sub>	-55 ~ +150	°C
*2	Soldering Temperature	T <sub>L</sub>	260	°C

\*1. AC For 1 Minute, R.H. = 40 ~ 60%

Isolation voltage shall be measured using the following method.

- (1) Short between anode and cathode on the primary side and between collector, emitter on the secondary side.
- (2) The isolation voltage tester with zero-cross circuit shall be used.
- (3) The waveform of applied voltage shall be a sine wave.

\*2. For 10 Seconds

**ELECTRICAL - OPTICAL CHARACTERISTICS**

( Ta = 25°C )

PARAMETER		SYMBOL	MIN.	TYP.	MAX.	UNIT	CONDITIONS
INPUT	Forward Voltage	$V_F$	—	1.2	1.4	V	$I_F=20mA$
	Reverse Current	$I_R$	—	0.05	10	$\mu A$	$V_R=6V$
OUTPUT	*1 Peak Blocking Current, Either Direction	$I_{DRM1}$	—	—	500	nA	$V_{DRM} = 600V$
	Peak On-State Voltage, Either Direction	$V_{TM}$	—	—	3.0	V	$I_{TM}=100 mA Peak$
	*2 Critical rate of Rise of Off-State Voltage	Dv/dt	600	1500	—	V/ $\mu s$	
COUPLED	*3 Led Trigger Current, Current Required to Latch Output, Either Direction	$I_{FT}$	—	—	5	mA	Main Terminal Voltage = 3V
	Holding Current, Either Direction	$I_H$	—	400	—	$\mu A$	
	Turn-On Time	$T_{ON}$	—	8	20	$\mu s$	$V_P=9V, I_F=20mA$ $R_L = 100\Omega$
ZERO CROSSING	Inhibit Voltage	$V_{INH}$	—	5	20	Volts	$I_F=Rated I_{FT}, MT1-MT2$ Voltage above which device will not trigger.
	Leakage in Inhibited State	$I_{DRM2}$	—	—	500	$\mu A$	$I_F = Rated I_{FT}, Rated V_{DRM}, Off State$

\*1 Test voltage must be applied within dv/dt rating.

\*2 This is static dv/dt. Commutating dv/dt is a function of the load-driving thyristor(s) only.

\*3 All devices are guaranteed to trigger at an  $I_F$  value less than or equal to max  $I_{FT}$ . Therefore, recommended operating  $I_F$  lies between max  $I_{FT}$  ( 5mA for MOC3063-V) and absolute max  $I_F$  (50mA)

**ISOLATION SPECIFICATION ACCORDING TO VDE 0884**

Parameter	Symbol	Conditions	Rating	Unit	Remark	
Class of environmental test	-	DIN IEC68	30/100/21	-		
Pollution	-	DIN VDE0110	2	-		
Maximum Operating Isolation Voltage	$V_{IORM}$	-	850	$V_{PEAK}$	Refer to the Diagram 1, 2	
Partial Discharge Test Voltage (Between Input and Output)	Diagram 1	$V_{pr}$	$t_p=60s, q_c<5pC$	1275		$V_{PEAK}$
	Diagram 2		$t_p=1s, q_c<5pC$	1594		$V_{PEAK}$
Maximum Over-voltage	$V_{INITIAL}$	$t_{INI} = 10s$	6000	$V_{PEAK}$		
Safety Maximum Ratings						
1) Case Temperature	$T_{si}$	$I_F = 0, P_c = 0$	130	°C	Refer to the Figure 1, 3	
2) Input Current	$I_{si}$	$P_c=0$	55	mA		
3) Electric Power (Output or Total Power Issipation)	$P_{si}$	-	160	mW		
Isolation Resistance (Test Voltage Between Input and Output : DC500V)	$R_{ISO}$	$T_a=T_{si}$	MIN.10 <sup>9</sup>	$\Omega$		
		$T_a=T_{opr}(MAX.)$	MIN.10 <sup>11</sup>			
		$T_a=25^\circ C$	MIN.10 <sup>12</sup>			

**Precautions in performing isolation test**

\* Partial discharge test methods shall be the ones according to the specifications of VDE 0884:1992-06

\* Please don't carry out isolation test ( $V_{iso}$ ) over  $V_{INITIAL}$  ,This product deteriorates isolation characteristics by partial discharge due to applying high voltage (ex.  $V_{INITIAL}$  ). And there is possibility that this product occurs partial discharge in operating isolation voltage ( $V_{IORM}$ )

## PARTIAL DISCHARGE TEST METHOD

Method (A) for type testing and random testing.

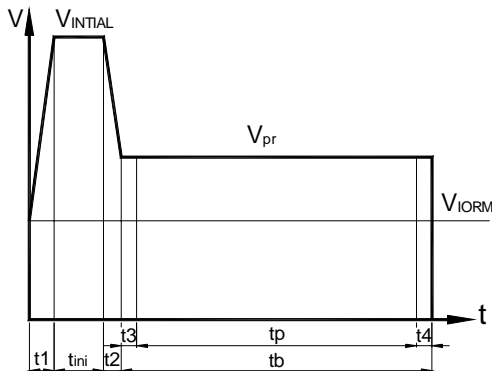

$t1, t2$  = 1 to 10s  
 $t3, t4$  = 1s  
 $t_p$  (Partial Discharge Measuring Time) = 60s  
 $t_b$  = 62s  
 $t_{ini}$  = 10s

Method (B) for routine testing.

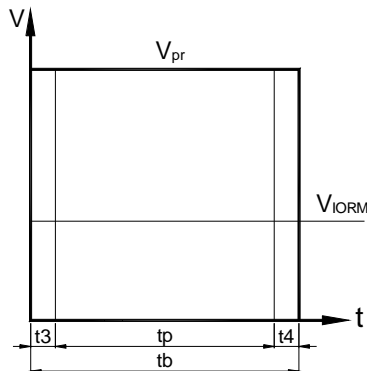

$t3, t4$  = 0.1s  
 $t_p$  (Partial Discharge Measuring Time) = 1s  
 $t_b$  = 1.2s

The partial discharge level shall not exceed 5 pC during the partial discharge measuring time interval  $t_p$  under the test conditions shown above.



**CHARACTERISTICS CURVES**

Fig.1 Forward Current vs. Ambient Temperature

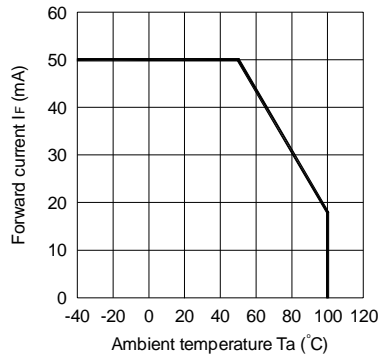

Fig.2 On-state Current vs. Ambient Temperature

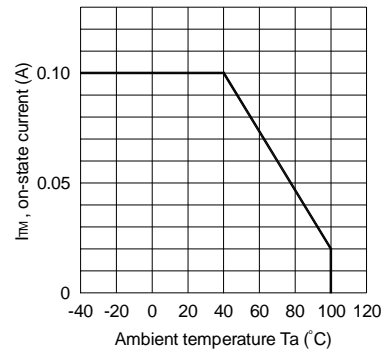

Fig.3 Minimum Trigger Current vs. Ambient Temperature

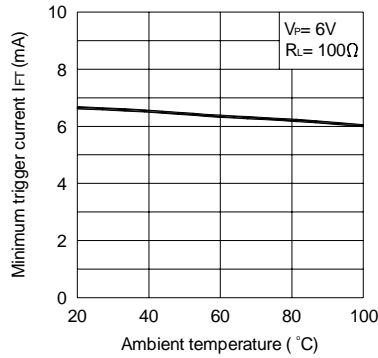

Fig.4 Forward Current vs. Forward Voltage

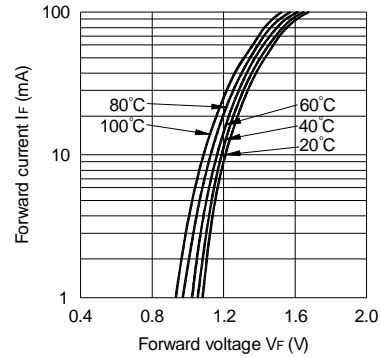

Fig.5 On-state Voltage vs. Ambient Temperature

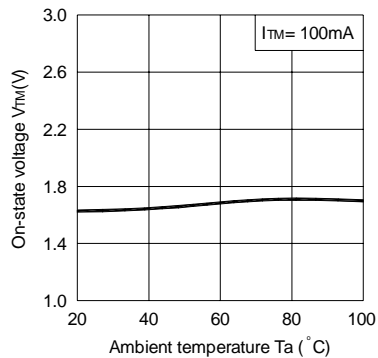
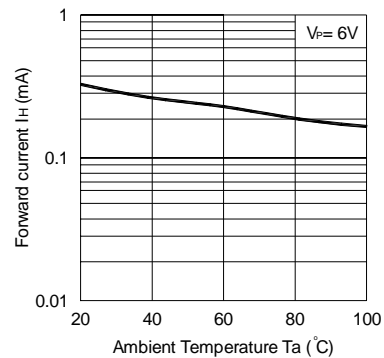

Fig.6 Holding Current vs. Ambient Temperature



## CHARACTERISTICS CURVES

Fig.7 Turn-on Time vs. Forward Current

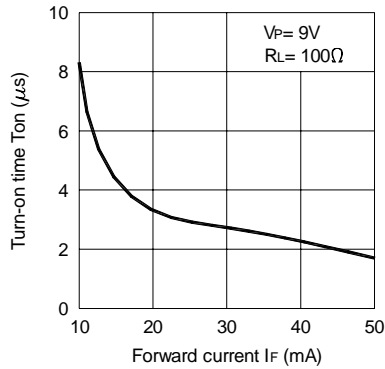

Fig.8 Repetitive Peak Off-state Current vs. Temperature

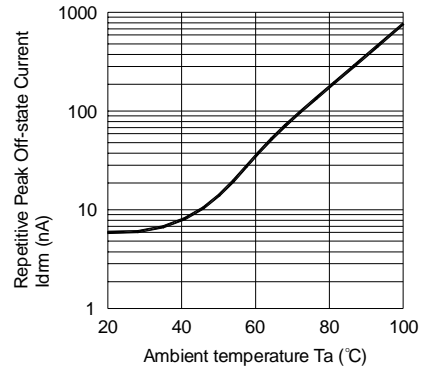
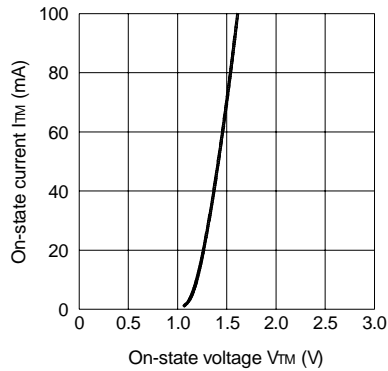
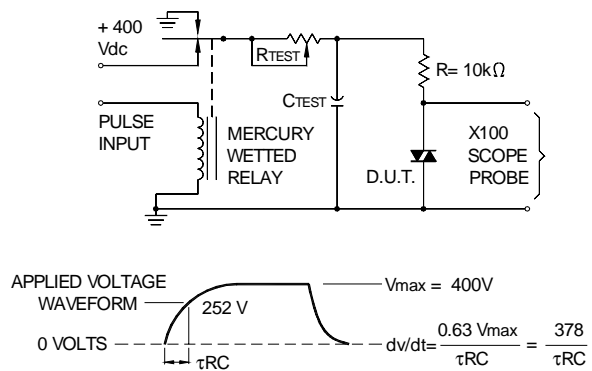

Fig.9 On-state Current vs. On-state Voltage



Static dv/dt Test Circuit



## RECOMMENDED FOOT PRINT PATTERNS (MOUNT PAD)

