

Am79Q02/021/031

Quad Subscriber Line Audio-Processing Circuit (QSLAC™) Devices



DISTINCTIVE CHARACTERISTICS

- Performs the functions of four codec/filters
- Software programmable:
 - SLIC input impedance
 - Transhybrid balance
 - Transmit and receive gains
 - Equalization (frequency response)
 - Digital I/O pins
 - Programmable debouncing on one input
 - Time slot assigner
 - Programmable clock slot and PCM transmit clock edge options
- Standard microprocessor interface
- A-law, μ -law, or linear coding
- Single or Dual PCM ports available
 - Up to 128 channels (PCLK at 8.192 MHz) per PCM port
 - Optional supervision on the PCM highway
- 1.536, 1.544, 2.048, 3.072, 3.088, 4.096, 6.144, 6.176, or 8.192 MHz master clock derived from MCLK or PCLK
- Built-in test modes with loopback, tone generation, and μ P access to PCM data
- Low-power, 5.0 V CMOS technology
- 5.0 V only operation
- Mixed state (analog and digital) impedance scaling
- Performance characteristics guaranteed over a 12 dB gain range
- Real Time Data register with interrupt (open drain or TTL output)
- Supports multiplexed SLIC inputs
- Broadcast state
- 256 kHz or 293 kHz chopper clock for Legerity SLICs with switching regulator
- Maximum channel bandwidth for V.34 modems

GENERAL DESCRIPTION

The Am79Q02/021/031 Quad Subscriber Line Audio-Processing Circuit (QSLAC) devices integrate the key functions of analog linecards into high-performance, very-programmable, four-channel codec-filter devices. The QSLAC devices are based on the proven design of Legerity's reliable SLAC™ device families. The advanced architecture of the QSLAC devices implements four independent channels and employs digital filters to allow software control of transmission, thus providing a cost-effective solution for the audio-processing function of programmable linecards.

Advanced submicron CMOS technology makes the Am79Q02/021/031 QSLAC devices economical, with both the functionality and the low power consumption needed in linecard designs to maximize linecard density at minimum cost. When used with four Legerity SLICs, a QSLAC device provides a complete software-configurable solution to the BORSCHT functions.

TABLE OF CONTENTS

Distinctive Characteristics	1
General Description	1
Block Diagram	4
Ordering Information	5
Connection Diagrams	6
Pin Descriptions	8
Functional Description	10
Absolute Maximum Ratings	11
Operating Ranges	11
Electrical Characteristics	12
Transmission Characteristics	13
Attenuation Distortion	14
Group Delay Distortion	14
Variation of Gain with Input Level	15
Total Distortion, Including Quantizing Distortion	16
Discrimination against Out-of-Band Input Signals	17
Discrimination against 12- and 16 kHz Metering Signals	18
Spurious Out-of-Band Signals at the Analog Output	18
Overload Compression	19
Switching Characteristics (PCM/MPI Mode)	20
Microprocessor Interface	20
PCM Interface	20
Master Clock	21
Auxiliary Output Clocks	21
Switching Waveforms	21
Input and Output Waveforms for AC Tests	21
Master Clock Timing	21
Microprocessor Interface (Input Mode)	22
Microprocessor Interface (Output Mode)	22
PCM Highway Timing for XE = 0 (Transmit on Negative PCLK Edge)	23
PCM Highway Timing for XE = 1 (Transmit on Positive PCLK Edge)	24
Operating the QSLAC Device	25
Power-Up Sequence	25
Channel Enable Register	25
SLIC Control and Data Lines	25
Clock Mode Operation	25
E1 Multiplex Operation	26
Debounce Filters Operation	29
Real-Time Data Register Operation	31
Interrupt	31
Interrupt Mask Register	31
Active State	31
Inactive State	31
Low Power State	31
Chopper Clock	31
Reset States	31
Signal Processing	32
Overview of Digital Filters	32
Two-Wire Impedance Matching	33
Frequency Response Correction and Equalization	33
Transhybrid Balancing	33
Gain Adjustment	33

Transmit Signal Processing	33
Transmit PCM Interface	33
Receive Signal Processing	34
Receive PCM Interface	34
Analog Impedance Scaling Network (AISN)	34
Speech Coding	35
Signaling on the PCM Highway	35
Robbed-Bit Signaling Compatibility	35
Default Filter Coefficients.	36
Command Description and Formats	36
Microprocessor Interface Description	36
Summary of MPI Commands*	38
MPI Command Structure	39
Programmable Filters.	56
General Description of CSD Coefficients.	56
User Test States and Operating Conditions.	57
A-Law and μ -Law Companding	58
Applications	60
Physical Dimensions	61
Revision Summary.	64

LIST OF FIGURES

Figure 1	Attenuation Distortion.	14
Figure 2	Group Delay Distortion.	14
Figure 3	A-Law/ μ -Law Gain Tracking with Tone Input (Both Paths)	15
Figure 4	A-Law/ μ -Law Total Distortion with Tone Input (Both Paths)	16
Figure 5	Discrimination Against Out-of-Band Signals	17
Figure 6	Spurious Out-of-Band Signals	18
Figure 7	A/A Overload Compression	19
Figure 8	Clock Mode Option.	26
Figure 9	SLIC I/O, E1 Multiplex, and Real-Time Data Register Operation	28
Figure 10	E1 Multiplex Internal Timing.	29
Figure 11	MPI Real-Time Data Register or GCI Upstream SC Channel Data.	30
Figure 12	QSLAC Device Block Diagram.	32
Figure 13	Robbed-Bit Frame	36

LIST OF TABLES

Table 1	dBm0 Voltage Definitions with Unity Gain in X, R, GX, GR, AX, and AR	13
Table 2	A-Law: Positive Input Values	58
Table 3	μ -Law: Positive Input Values	59

BLOCK DIAGRAM

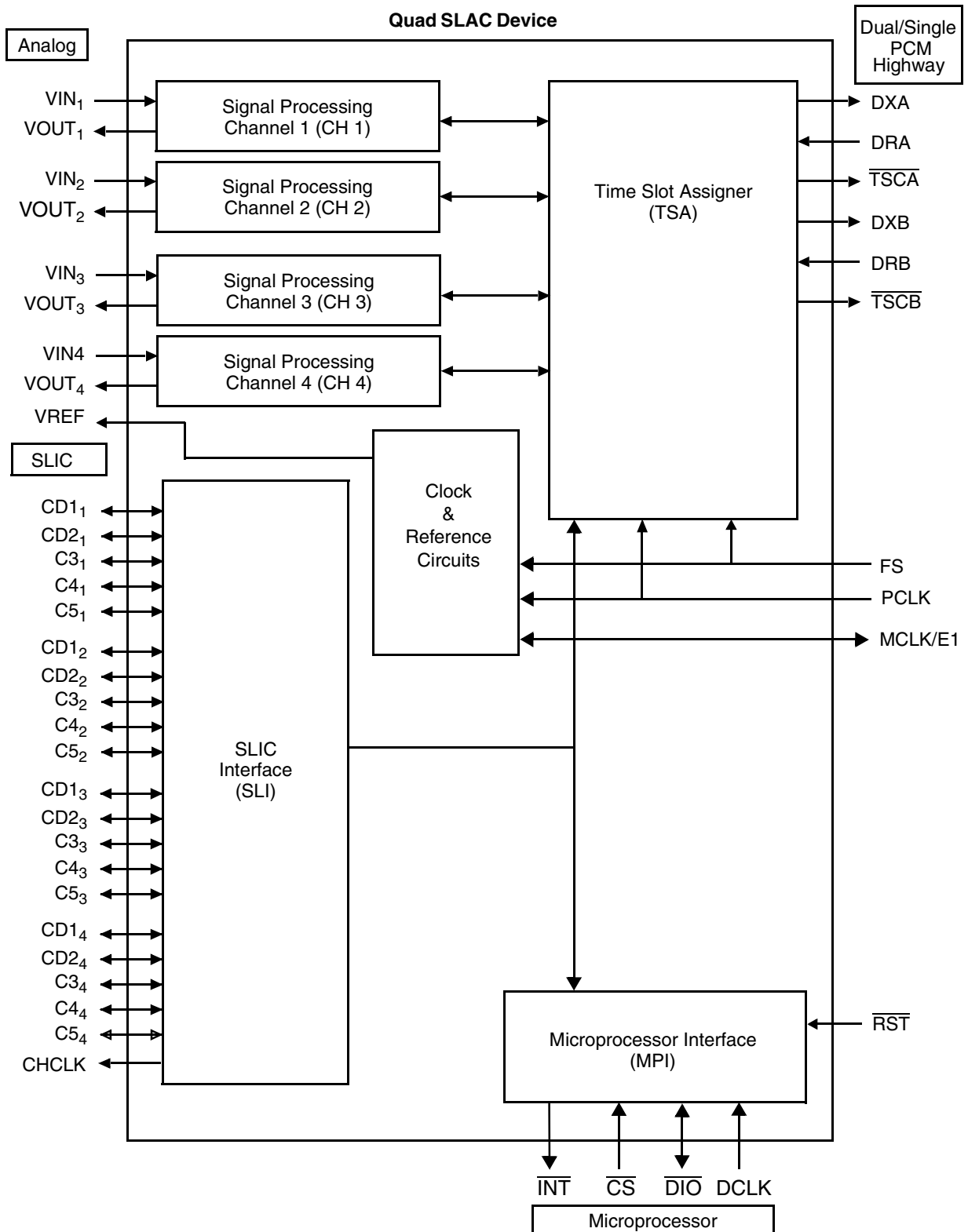

19256A-001

ORDERING INFORMATION

Standard Products

Legerity standard products are available in several packages and operating ranges. The order number (Valid Combination) is formed by a combination of the elements below.

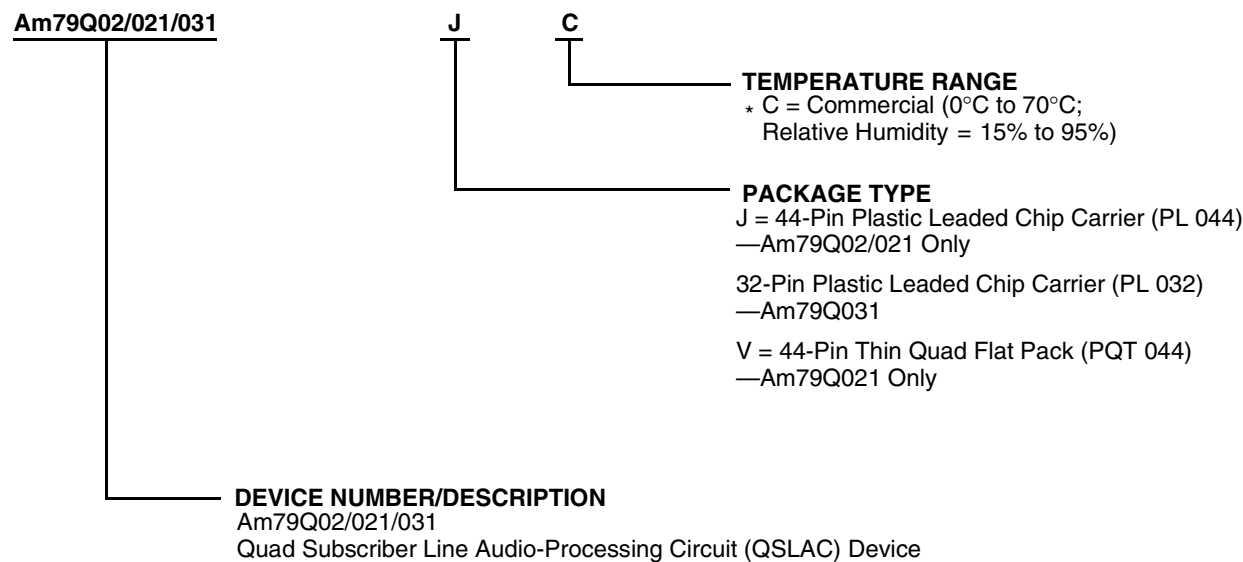

Valid Combinations	
Am79Q02	JC
Am79Q021	JC
Am79Q031	JC
Am79Q021	VC

Valid Combinations

Valid Combinations list configurations planned to be supported in volume for this device. Consult the local Legerity sales office to confirm availability of specific valid combinations, to check on newly released combinations, and to obtain additional data on Legerity's standard military-grade products.

Note:

* Functionality of the device from 0°C to +70°C is guaranteed by production testing. Performance from -40°C to +85°C is guaranteed by characterization and periodic sampling of production units.

CONNECTION DIAGRAMS (PLCC PACKAGES)

Top View

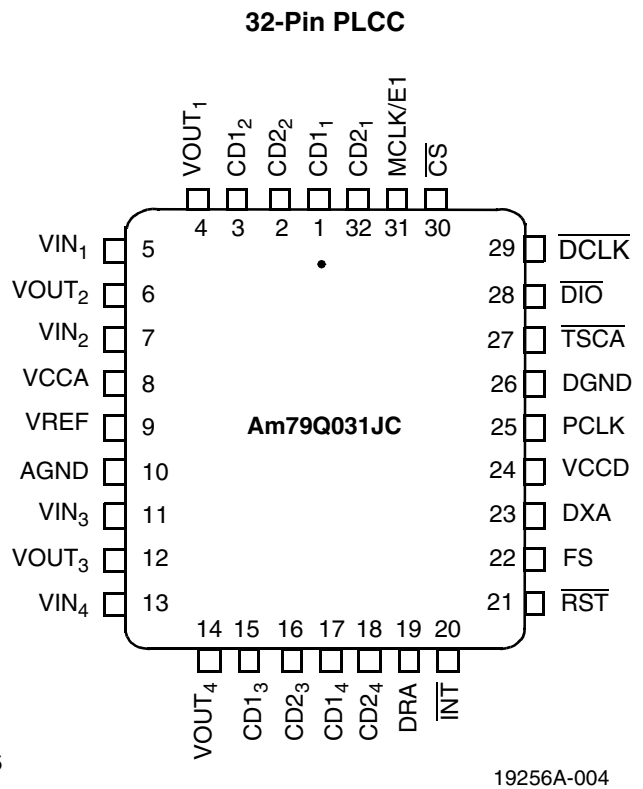
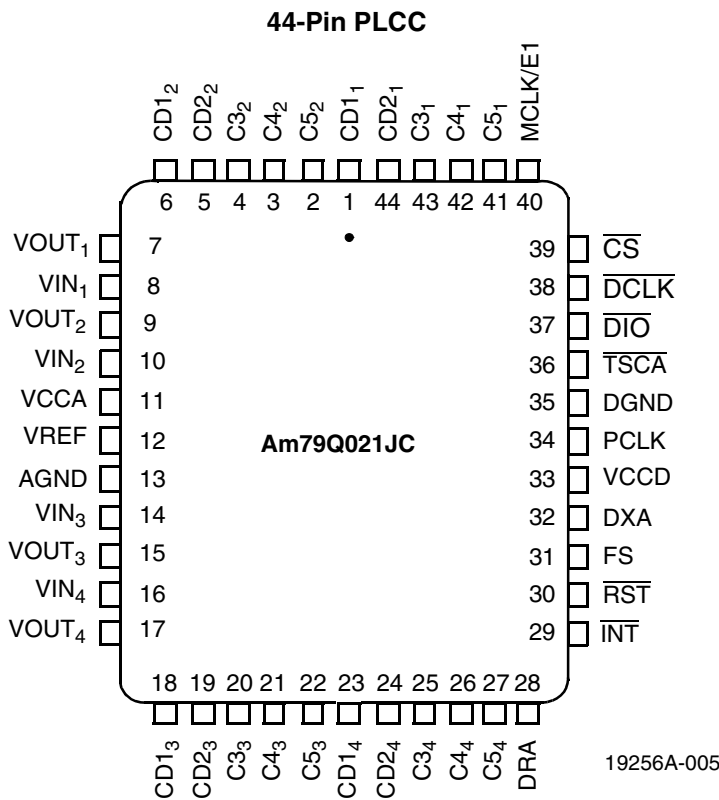
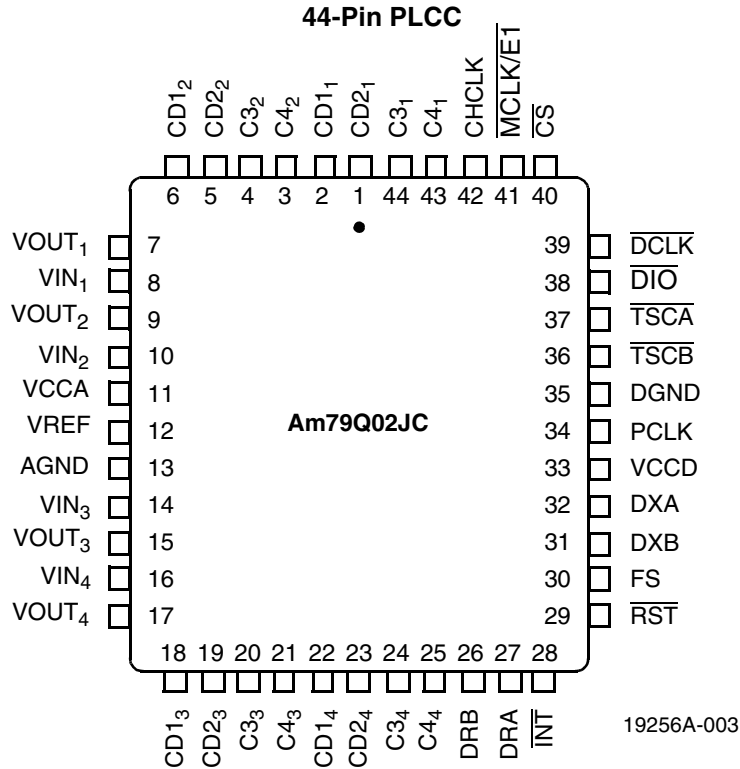

Notes:

1. Pin 1 is marked for orientation.
2. RSVD = Reserved pin; should not be connected externally to any signal or supply.

CONNECTION DIAGRAM (TQFP PACKAGE)

Top View

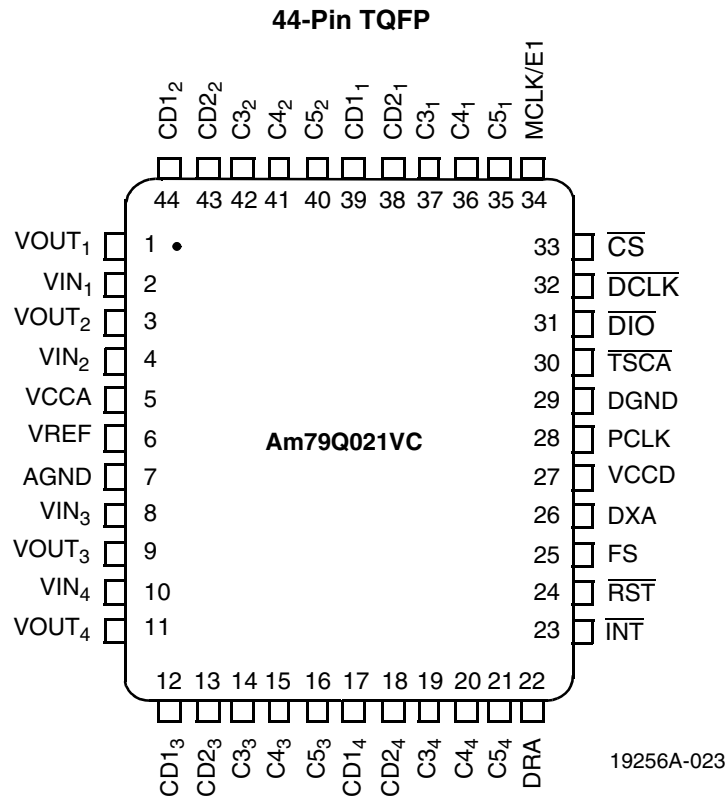

Notes:

1. Pin 1 is marked for orientation.
2. RSVD = Reserved pin; should not be connected externally to any signal or supply.

PIN DESCRIPTIONS

Pin Names	Type	Description
CD1 ₁ –CD1 ₄ , CD2 ₁ –CD2 ₄	Inputs/Outputs	<p>Control and Data. CD1 and CD2 are TTL compatible programmable Input or Output (I/O) ports. They can be used to monitor or control the state of SLIC or any other device associated with subscriber line interface. The direction, input or output, is programmed using MPI Command 22. As outputs, CD1 and CD2 can be used to control relays, illuminate LEDs, or perform any other function requiring a latched TTL compatible signal for control. The output state of CD1 and CD2 is written using MPI Command 20. As inputs, CD1 and CD2 can be processed by the QSLAC device (if programmed to do so). CD1 can be debounced before it is made available to the system. The debounce time is programmable from 0 to 15 ms in 1 ms increments using MPI Command 45. CD2 can be filtered using the up/down counter facility and programming the sampling interval using MPI Command 52.</p> <p>Additionally, CD1 can be demultiplexed into two separate inputs using the E1 demultiplexing function. The E1 demultiplexing function of the QSLAC device was designed to interface directly to Legerity SLICS supporting the ground key function. With the proper Legerity SLIC and the E1 function of the QSLAC enabled, the CD1 bit can be demultiplexed into an Off-Hook/Ring Trip signal and Ground Key signal. In the demultiplex mode, the second bit, Ground Key, takes the place of the CD2 as an input. The demultiplexed bits can be debounced (CD1) or filtered (CD2) as explained previously. A more complete description of CD1, CD2, debouncing, and filtering functions is contained in the <i>Operating the QSLAC Device</i> section on page 25.</p> <p>Once the CD1 and CD2 inputs are processed (Debounced, Filtered and/or Demultiplexed) by the QSLAC device, the information can be accessed by the system in two ways: 1) on a per channel basis along with C3, C4, and C5 of the specific channel using MPI Command 21, or 2) by using MPI Commands 16 and 17, which obtain the CD1 and CD2 bits from all four channels simultaneously. This feature reduces the processor overhead and the time required to retrieve time-critical signals from the line circuits, such as off-hook and ring trip. With this feature, hookswitch status and ring trip information, for example, can be obtained from all four channels of a QSLAC device with one read command.</p>
C3 ₁ –C3 ₄ , C4 ₁ –C4 ₄ , C5 ₁ –C5 ₄	Inputs/Outputs	<p>Control. C3, C4, and C5 are TTL-compatible programmable Input or Output (I/O) ports. They can be used to monitor or control the state of SLIC or any other device associated with subscriber line interface. The direction, input or output, is programmed using MPI Command 22. As outputs, C3, C4, and C5 can be used to control relays, illuminate LEDs, or perform any other function requiring a latched TTL compatible signal for control. The output state of C3, C4, and C5 is written using MPI Command 20. As inputs, C3, C4, and C5 can be accessed by the system by using MPI Command 21.</p> <p>The Am79Q021 QSLAC device contains a single PCM highway and five programmable I/Os per channel (CD1, CD2, C3, C4, and C5) in a 44-pin PLCC or TQFP package. In the Am79Q02 QSLAC device, the C5₁, C5₂, C5₃, and C5₄ I/Os are eliminated, enabling dual PCM highways and a chopper clock output in a 44-pin PLCC or TQFP package. In the Am79Q031 QSLAC device, the C3₁–C5₁, C3₂–C5₂, C3₃–C5₃, and C3₄–C5₄ I/Os are eliminated, enabling a single PCM highway and two control and data I/Os (CD1, CD2) per channel in a 32-pin PLCC package.</p>
CHCLK	Output	<p>Chopper Clock. This output provides a 256 kHz or a 292.57 kHz, 50% duty cycle, TTL-compatible clock for use by up to four SLICs with built-in switching regulators. The CHCLK frequency is synchronous to MCLK, but the phase relationship to MCLK is random. The chopper clock is not available in all package types.</p>
\overline{CS}	Input	<p>Chip Select. The Chip Select input (active Low) enables the device so that control data can be written to or read from the part. The channels selected for the write or read operation are enabled by writing 1 s to the appropriate bits in the Channel Enable Register of the QSLAC device prior to the command. See EC1, EC2, EC3, and EC4 of the Command 14, page 42, for more information. If Chip Select is held Low for 16 rising edges of DCLK, a hardware reset is executed when Chip Select returns High.</p>

Pin Names	Type	Description
DCLK	Input	Data Clock. The Data Clock input shifts data into and out of the microprocessor interface of the QSLAC device. The maximum clock rate is 4.096 MHz.
DIO	Input/Output	Data. Control data is serially written into and read out of the QSLAC device via the DIO pin, with the most significant bit first. The Data Clock determines the data rate. DIO is high impedance except when data is being transmitted from the QSLAC device.
DRA/DRB	Inputs	PCM Data Receive A/B. The PCM data for channels 1, 2, 3, and 4 is serially received on either the DRA or DRB port during user-programmed time slots. Data is always received with the most significant bit first. For compressed signals, 1 byte of data for each channel is received every 125 μ s at the PCLK rate. In the Linear state, two consecutive bytes of data for each channel are received every 125 μ s at the PCLK rate. DRB is not available on all package types.
DXA/DXB	Outputs	PCM Data Transmit. The transmit data from channels 1, 2, 3, and 4 is sent serially out on either the DXA or DXB port or both ports during user-programmed time slots. Data is always transmitted with the most significant bit first. The output is available every 125 μ s and the data is shifted out in 8-bit (16-bit in Linear or PCM Signaling state) bursts at the PCLK rate. DXA and DXB are High impedance between time slots, while the device is in the Inactive state with no PCM signaling, or while the Cutoff Transmit Path bit (CTP) is on. DXB is not available on all package types.
FS	Input	Frame Sync. The Frame Sync pulse is an 8 kHz signal that identifies Time Slot 0, Clock Slot 0 of a system's PCM frame. The QSLAC device references individual time slots with respect to this input, which must be synchronized to PCLK.
$\overline{\text{INT}}$	Output	Interrupt. $\overline{\text{INT}}$ is an active Low output signal which is programmable as either TTL compatible or open drain. The $\overline{\text{INT}}$ output goes Low any time one of the input bits in the Real Time Data register changes state and is not masked. It also goes Low any time new transmit data appears if this interrupt is armed. $\overline{\text{INT}}$ remains Low until the appropriate register is read via the microprocessor interface, or the QSLAC device receives either a software or hardware reset. The individual CD _x _y bits in the Real Time Data register can be masked from causing an interrupt by using Command 26 of the MPI. The transmit data interrupt must be armed with a bit in the Operating Conditions register.
MCLK/E1	Input/Output	Master Clock (Input)/Enable CD1 Multiplex (Output). The Master Clock can be a 1.536 MHz, 1.544 MHz, or 2.048 MHz (times 1, 2, or 4) clock for use by the digital signal processor. If the internal clock is derived from the PCM Clock Input (PCLK), this pin can be used as an E1 output to control Legerity SLICs having multiplexed hookswitch and ground-key detector outputs.
PCLK	Input	PCM Clock. The PCM clock determines the rate at which PCM data is serially shifted into or out of the PCM ports. PCLK is an integer multiple of the frame sync frequency. The maximum clock frequency is 8.192 MHz and the minimum clock frequency is 128 kHz for dual PCM highway versions and 256 kHz for single PCM highway versions. The minimum clock rate must be doubled if Linear state or PCM signaling is used. PCLK frequencies between 1.03 MHz and 1.53 MHz are not allowed. Optionally, the digital signal processor clock can be derived from PCLK rather than MCLK.
$\overline{\text{RST}}$	Input	Reset. A logic Low signal at this pin resets the QSLAC device to its default state. The $\overline{\text{RST}}$ pin may be tied to VCCD if it is not needed in the system.
$\overline{\text{TSCA}}$, $\overline{\text{TSCB}}$	Outputs	Time Slot Control. The Time Slot Control outputs are open drain outputs (requiring pull-up resistors to VCCD) and are normally inactive (High impedance). TSCA or TSCB is active (Low) when PCM data is transmitted on the DXA or DXB pin respectively.
VIN ₁ –VIN ₄	Inputs	Analog. The analog voice band signal is applied to the VIN input of the QSLAC device. The VIN input is biased at VREF by a large internal resistor. The audio signal is sampled, digitally processed and encoded, and then made available at the TTL-compatible PCM output (DXA or DXB). If the digitizer saturates in the positive or negative direction, VIN is pulled by a reduced resistance toward AGND or VCCD, respectively. VIN ₁ is the input for channel 1, VIN ₂ is the input for channel 2, VIN ₃ is the input for channel 3, and VIN ₄ is the input for channel 4.

Pin Names	Type	Description
VOUT ₁ – VOUT ₄	Outputs	Analog. The received digital data at DRA or DRB is processed and converted to an analog signal at the VOUT pin. VOUT ₁ is the output from channel 1, VOUT ₂ is the output for channel 2, VOUT ₃ is the output from channel 3, and VOUT ₄ is the output for channel 4. The VOUT voltages are referenced to VREF.
VREF	Output	Analog Voltage Reference. The VREF output is provided in order for an external 0.1 μF capacitor to be connected from VREF to ground, filtering noise present on the internal voltage reference. VREF is buffered before it is used by internal circuitry. The voltage on VREF is nominally 2.1 V, and the output resistance is 100 kΩ ±30%. The leakage current in the capacitor must be less than 20 nA.

Power Supply

- AGND Analog ground
- DGND Digital ground
- VCCA +5.0 V analog power supply
- VCCD +5.0 V digital power supply

Two separate power supply inputs are provided to allow for noise isolation and proper power supply decoupling techniques; however, the two pins have a low impedance connection inside the part. For best performance, all of the +5.0 power supply pins should be connected together at the connector of the printed circuit board, and all of the grounds should be connected together at the connector of the printed circuit board.

FUNCTIONAL DESCRIPTION

The QSLAC device performs the codec/filter and two- to four-wire conversion functions required of the subscriber line interface circuitry in telecommunications equipment. These functions involve converting audio signals into digital PCM samples and converting digital PCM samples back into audio signals. During conversion, digital filters are used to band limit the voice signals. All of the digital filtering is performed in digital signal processors operating from a master clock, which can be derived either from PCLK or MCLK.

Four independent channels allow the QSLAC device to function as four SLAC devices or two DSLAC™ devices. For programming information, each channel has its own enable bit (EC1, EC2, EC3, and EC4) to allow individual channel programming. If more than one Channel Enable bit is High or if all Channel Enable

bits are High, all channels enabled will receive the programming information written; therefore, a Broadcast state can be implemented by simply enabling all channels in the device to receive the information. The Channel Enable bits are contained in the Channel Enable register, which is written and read using Commands 14 and 15. The Broadcast state is useful in initializing QSLAC devices in a large system.

The user-programmable filters set the receive and transmit gain, perform the transhybrid balancing function, permit adjustment of the two-wire termination impedance, and provide equalization of the receive and transmit paths. All programmable digital filter coefficients can be calculated using the AmSLAC4 or WinSLAC™ software.

Data transmitted or received on the PCM highway can be 8-bit companded code (with an optional 8-bit signaling byte in the transmit direction) or 16-bit linear code. The 8-bit codes appear 1 byte per time slot, while the 16-bit code appears in two consecutive time slots. The compressed PCM codes can be either 8-bit companded A-law or μ-law. The PCM data is read from and written to the PCM highway in user-programmable time slots at rates of 128 kHz to 8.192 MHz. The transmit clock edge and clock slot can be selected for compatibility with other devices that can be connected to the PCM highway.

Three configurations of the QSLAC device are offered with single or dual PCM highways. The Am79Q02 and Am79Q021 QSLAC devices with dual and single PCM highways respectively are available in the 44-pin packages. The Am79Q031JC QSLAC device is a single PCM highway version in a 32-pin PLCC package.

PCM Highway	Programmable I/O	Chopper Clock	Package	Part Number
Dual	Four	Yes	44 PLCC/TQFP	Am79Q02 JC
Single	Five	No	44 PLCC/TQFP	Am79Q021 JC (or VC)
Single	Two	No	32 PLCC	Am79Q031 JC

ABSOLUTE MAXIMUM RATINGS

Storage Temperature	$-60^{\circ}\text{C} < T_A < +125^{\circ}\text{C}$
Ambient Operating Temperature	$-40^{\circ}\text{C} < T_A < +85^{\circ}\text{C}$
Ambient Relative Humidity	5% to 95% (non-condensing)
V_{CCA} with respect to AGND	$-0.4\text{ V to }+7.0\text{ V}$
V_{CCA} with respect to VCCD	$\pm 50\text{ mV}$
V_{CCD} with respect to DGND	$-0.4\text{ V to }+7.0\text{ V}$
V_{IN} with respect to AGND	$-0.4\text{ V to } (V_{CCA} + 0.4\text{ V})$
AGND with respect to DGND	$\pm 0.4\text{ V}$
Other pins	
with respect to DGND	$-0.4\text{ V to } V_{CCD} + 0.4\text{ V}$
Total combined CD1–C5 current per device:	
Source from VCCD	40 mA
Sink into DGND	40 mA
Latch-up immunity (any pin)	$\pm 100\text{ mA}$

Stresses above those listed under Absolute Maximum Ratings may cause permanent device failure. Functionality at or above these limits is not implied. Exposure to Absolute Maximum Ratings for extended periods may affect device reliability.

OPERATING RANGES

V_{CCA} , Analog Supply	$+5.0\text{ V} \pm 0.25\text{ V}$
V_{CCA} , Analog Supply	$V_{CCD} \pm 10\text{ mV}$
V_{CCD} , Digital Supply	$+5.0\text{ V} \pm 0.25\text{ V}$
DGND	0 V
AGND	$\pm 50\text{ mV}$
Ambient Temperature	$0^{\circ}\text{C} < T_A < +70^{\circ}\text{C}$
Ambient Relative Humidity	15% to 95%

Operating Ranges define those limits between which functionality of the device is guaranteed by production testing.

Functionality of the device from 0°C to $+70^{\circ}\text{C}$ is guaranteed by production testing. Performance from -40°C to $+85^{\circ}\text{C}$ is guaranteed by characterization and periodic sampling of production units.

ELECTRICAL CHARACTERISTICS

Typical values are for $T_A = 25^\circ\text{C}$ and nominal supply voltages. Minimum and maximum values are over the temperature and supply voltage ranges shown in Operating Ranges.

Symbol	Parameter Descriptions	Min	Typ	Max	Unit	Note
V_{IL}	Input Low voltage			0.8	V	
V_{IH}	Input High voltage	2.0				
I_{IL}	Input leakage current	-10		+10	μA	
V_{OL}	Output Low voltage				V	1
	CD1–C5 ($I_{OL} = 4 \text{ mA}$)			0.4		
	CD1–C5 ($I_{OL} = 8 \text{ mA}$)			0.8		
	\overline{TSCA} , \overline{TSCB} ($I_{OL} = 14 \text{ mA}$)			0.4		
	Other digital outputs ($I_{OL} = 2 \text{ mA}$)			0.4		
V_{OH}	Output High voltage					1
	CD1–C5 ($I_{OH} = 4 \text{ mA}$)	$V_{CCD} - 0.4 \text{ V}$				
	CD1–C5 ($I_{OH} = 8 \text{ mA}$)	$V_{CCD} - 0.8 \text{ V}$				
	Other digital outputs ($I_{OH} = 400 \mu\text{A}$)	2.4				
I_{OL}	Output leakage current ($H_I = Z$ state)	-10		10	μA	
V_{IR}	Analog input voltage range($AX = 0 \text{ dB}$) (Relative to V_{REF})($AX = 6.02 \text{ dB}$)		± 1.584 ± 0.792		Vpk	
V_{IOS}	Offset voltage allowed on V_{IN}	-50		50	mV	
Z_{IN}	Analog input impedance to V_{REF} 300 to 3400 Hz	0.43		3.4	$\text{M}\Omega$	
I_{IP}	Current into analog input for input voltages between 3.8 V and 5.0 V	54		170	μA	2
I_{IN}	Current out of analog input for input voltages between 0 V and 0.5 V	50		170		2
Z_{OUT}	V_{OUT} output impedance		1	10	Ω	3
I_{OUT}	V_{OUT} output current ($F < 3400 \text{ Hz}$)	-4		4	mApk	
Z_{REF}	V_{REF} output impedance ($F < 3400 \text{ Hz}$)	70		130	$\text{k}\Omega$	
V_{OR}	V_{OUT} voltage range($AR = 0 \text{ dB}$) (Relative to V_{REF})($AR = 6.02 \text{ dB}$)		± 1.584 ± 0.792		Vpk	
V_{OOS}	V_{OUT} offset voltage (AISN off)	-40		40	mV	4
V_{OOSA}	V_{OUT} offset voltage (AISN on)	-80		80		
LIN_{AISN}	Linearity of AISN circuitry (input = 0 dBm0)	-0.25		0.25	LSB	
PD	Power dissipation				mW	5
	All channels active		200	260		
	1 channel active		70	130		
	All channels inactive, (in normal state)		18	25		
	All channels inactive (in low power state)		6	12		
C_I	Input capacitance (Digital)		15		pF	
C_O	Output capacitance (Digital)		15			
PSRR	Power supply rejection ratio (1.02 kHz, 100 mV _{RMS} , either path, $G_X = G_R = 0 \text{ dB}$)	40			dB	

Notes:

1. The CD1, CD2, C3–C5 outputs are resistive for less than a 0.8 V drop. Total current must not exceed absolute maximum ratings.
2. When the digitizer saturates, a resistor of $50 \text{ k}\Omega \pm 20 \text{ k}\Omega$ is connected either to DGND or to V_{CCD} — (1 diode drop) as appropriate to discharge the coupling capacitor.
3. When the QSLAC device is in the Inactive state, the analog output will present either a V_{REF} DC output level through a $15 \text{ k}\Omega$ resistor ($V_{MODE} = 0$) or a high impedance ($V_{MODE} = 1$).
4. If there is an external DC path from V_{OUT} to V_{IN} with a gain of G_{DC} and the AISN has a gain of h_{AISN} , then the output offset will be multiplied by $1/[1 - (h_{AISN} \cdot G_{DC})]$.
5. Power dissipation in the Inactive state is measured with all digital inputs at $V_{IH} = V_{CC}$ and $V_{IL} = \text{DGND}$ and with no load connected to V_{OUT}_1 , V_{OUT}_2 , V_{OUT}_3 , or V_{OUT}_4 .

Transmission Characteristics

Table 1. 0 dBm0 Voltage Definitions with Unity Gain in X, R, GX, GR, AX, and AR

Signal at Digital Interface	Transmit	Receive	Unit
A-law digital mW or equivalent (0 dBm0)	0.7804	0.7804	Vrms
μ-law digital mW or equivalent (0 dBm0)	0.7746	0.7746	
±22,827 peak linear coded sine wave	0.7804	0.7804	

When relative levels (dBm0) are used in any of the following transmission specifications, the specification holds for any setting of the GX gain from 0 dB to 12 dB and the GR loss from 0 dB to 12 dB.

Description	Test Conditions	Min	Typ	Max	Unit	Note	
Gain accuracy, D/A or A/D	0 dBm0, 1014 Hz AX = AR = 0 dB 0 to 85°C -40°C AX = +6.02 dB and/or AR = -6.02 dB 0 to 85°C -40°C	-0.25 -0.30		+0.25 +0.30	dB		
Gain accuracy digital-to-digital		-0.25		+0.25			
Gain accuracy analog-to-analog		-0.25		+0.25			
Attenuation distortion	300 Hz to 3 kHz	-0.125		+0.125			1
Single frequency distortion				-46			2
Idle channel noise							
Analog out	Digital looped back weighted unweighted			-68 -55	dBm0p dBm0	3 3	
Digital out	Digital input = 0 A-law Digital input = 0 μ-law Analog V _{IN} = 0 VAC A-law Analog V _{IN} = 0 VAC μ-law		0 0	12 16	dBrnc0 dBrnc0	3, 6 3, 6	
CrosstalkTX to RX same channelRX to TX	0 dBm0 300 Hz to 3400 Hz 0 dBm0 300 Hz to 3400 Hz			-75 -75	dBm0		
Crosstalk between channels TX or RX to TX TX or RX to RX	0 dBm0 1014 Hz, Average 1014 Hz, Average			-76 -78			4
End-to-end group delay	B = Z = 0; X = R = 1			678	μs	5	

Notes:

- Also see Figure 1 and Figure 2.
- 0 dBm0 input signal, 300 Hz to 3400 Hz; measurement at any other frequency, 300 Hz to 3400 Hz.
- No single frequency component in the range above 3800 Hz may exceed a level of -55 dBm0.
- The weighted average of the crosstalk is defined by the following equation, where C(f) is the crosstalk in dB as a function of frequency, f_N = 3300 Hz, f₁ = 300 Hz, and the frequency points (f_j, j = 2..N) are closely spaced:

$$\text{Average} = 20 \cdot \log \left[\frac{\sum_j \frac{\frac{1}{20} \cdot C(f_j)}{10^{20}} + \frac{\frac{1}{20} \cdot C(f_{j-1})}{10^{20}}}{2} \cdot \log \left(\frac{f_j}{f_{j-1}} \right)}{\log \left(\frac{f_N}{f_1} \right)} \right]$$

- The End-to-End Group Delay is the sum of the transmit and receive group delays (both measured using the same time and clock slot).
- Typical values not tested in production.

Attenuation Distortion

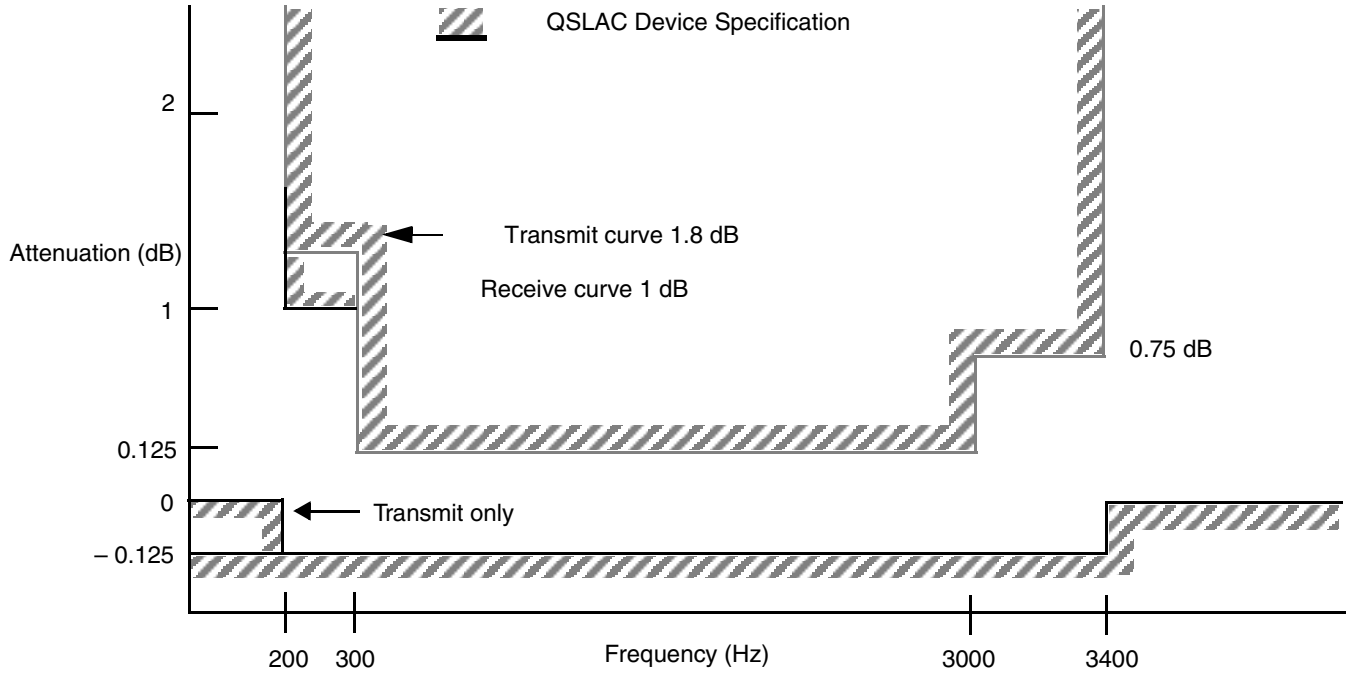

Figure 1. Attenuation Distortion

19256A-006

Group Delay Distortion

For either transmission path, the group delay distortion is within the limits shown in Figure 2. The minimum value of the group delay is taken as the reference. The signal level should be 0 dBm0.

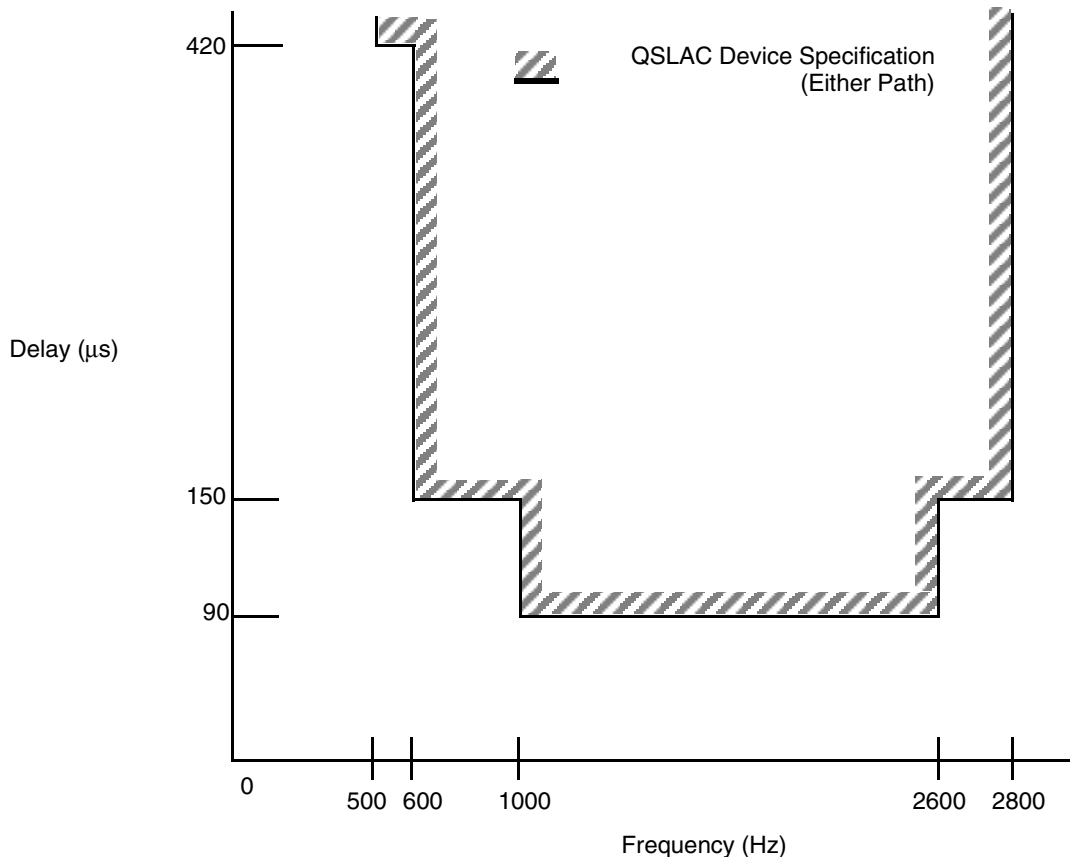
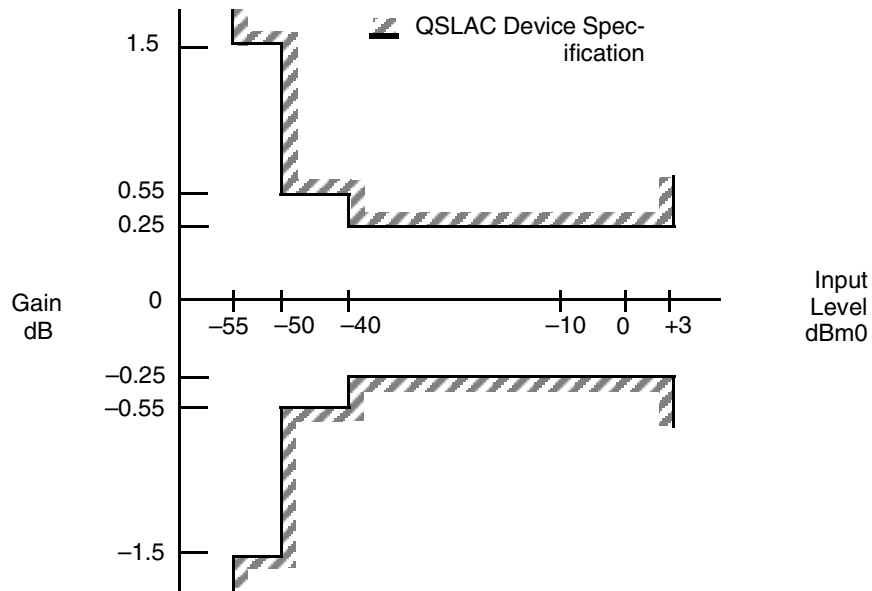

Figure 2. Group Delay Distortion

19256A-007

Variation of Gain with Input Level

The gain deviation relative to the gain at -10 dBm0 is within the limits shown in Figure 3 for either transmission path when the input is a sine wave signal of frequency 1014 Hz.



19256A-008

a. A-law

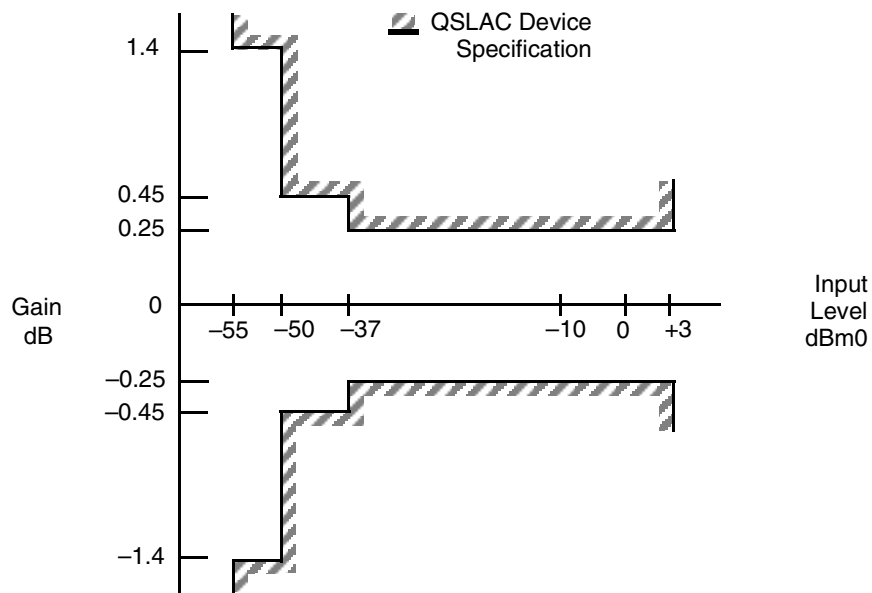

19256A-009

b. μ -law

Figure 3. A-law/ μ -law Gain Tracking with Tone Input (Both Paths)

Total Distortion, Including Quantizing Distortion

The signal-to-total distortion will exceed the limits shown in Figure 4 for either transmission path when the input is a sine wave signal of frequency 1014 Hz.

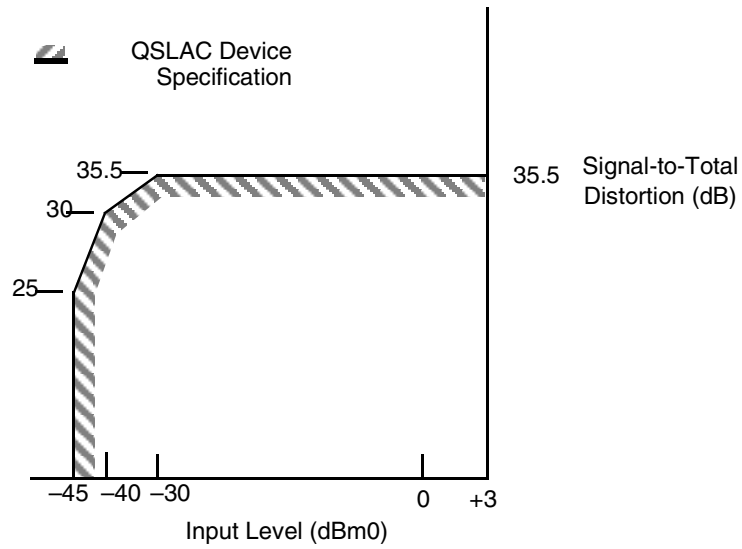

a. A-law

19256A-010

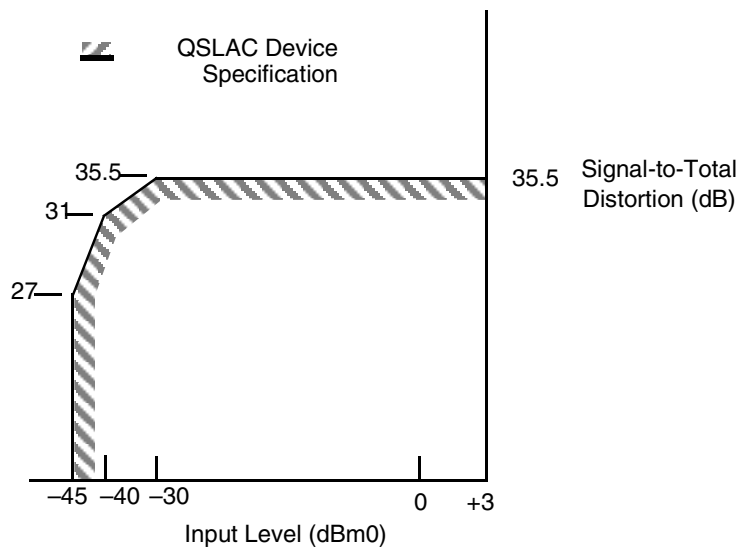

b. μ -law

19256A-011

Figure 4. A-law/ μ -law Total Distortion with Tone Input (Both Paths)

Discrimination against Out-of-Band Input Signals

When an out-of-band sine wave signal with frequency and level A is applied to the analog input, there may be frequency components below 4 kHz at the digital output which are caused by the out-of-band signal. These components are at least the specified dB level below the level of a signal at the same output originating from a 1014 Hz sine wave signal with a level of A dBm0 also applied to the analog input. The minimum specifications are shown in the following table.

Frequency of Out-of-Band Signal	Amplitude of Out-of-Band Signal	Level below A
16.6 Hz < f < 45 Hz	-25 dBm0 < $A \leq 0$ dBm0	18 dB
45 Hz < f < 65 Hz	-25 dBm0 < $A \leq 0$ dBm0	25 dB
65 Hz < f < 100 Hz	-25 dBm0 < $A \leq 0$ dBm0	10 dB
3400 Hz < f < 4600 Hz	-25 dBm0 < $A \leq 0$ dBm0	see Figure 5
4600 Hz < f < 100 kHz	-25 dBm0 < $A \leq 0$ dBm0	32 dB

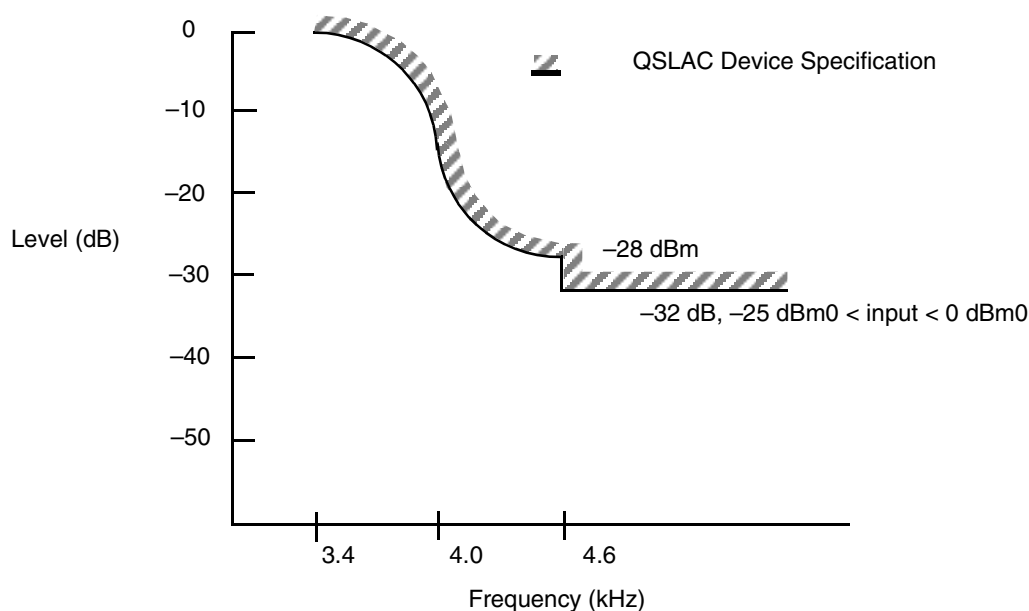

19256A-012

Note:

The attenuation of the waveform below amplitude A between 3400 Hz and 4600 Hz is given by the formula:

$$\text{Attenuation (db)} = 14 - 14 \sin \frac{\pi(4000 - f)}{1200}$$

Figure 5. Discrimination Against Out-of-Band Signals

Discrimination against 12- and 16-kHz Metering Signals

If the QSLAC device is used in a metering application where 12-kHz or 16-kHz tone bursts are injected onto the telephone line toward the subscriber, a portion of those tones may also appear at the VIN terminal. These out-of-band signals may cause frequency components to appear below 4 kHz at the digital output. For a 12 kHz or 16 kHz tone, the frequency components below 4 kHz will be reduced from the input by at least 70 dB. The sum of the peak metering and signal voltages must be within the analog input voltage range.

Spurious Out-of-Band Signals at the Analog Output

With PCM code words representing a sine wave signal in the range of 300 Hz to 3400 Hz at a level of 0 dBm0 applied to the digital input, the level of the spurious out-of-band signals at the analog output is less than the limits shown below.

Frequency	Level
4.6 kHz to 40 kHz	-32 dBm0
40 kHz to 240 kHz	-46 dBm0
240 kHz to 1 MHz	-36 dBm0

With code words representing any sine wave signal in the range 3.4 kHz to 4.0 kHz at a level of 0 dBm0 applied to the digital input, the level of the signals at the analog output are below the limits in Figure 6. The amplitude of the spurious out-of-band signals between 3400 Hz and 4600 Hz is given by the formula:

$$A = -14 - 14 \sin \frac{\pi(f - 4000)}{1200} \text{dBm0}$$

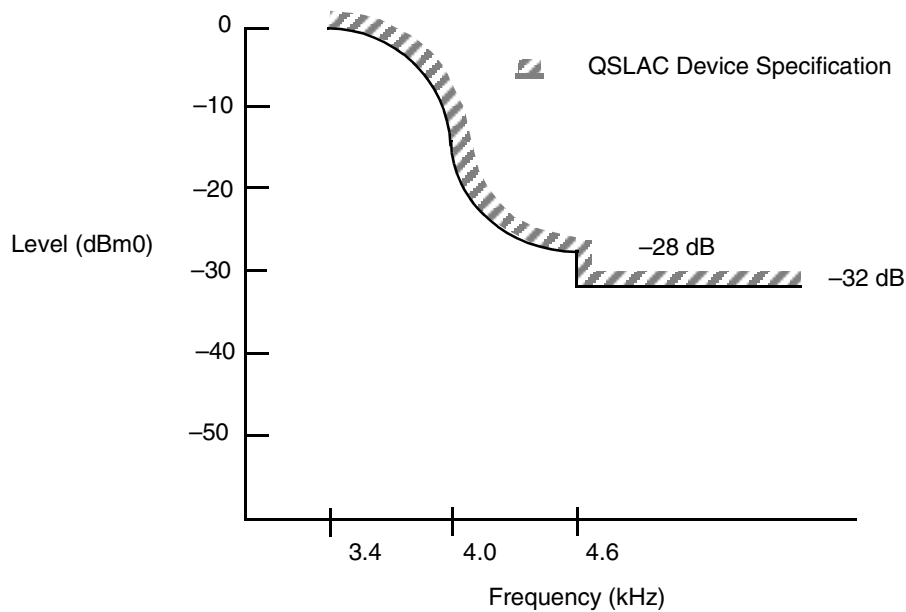
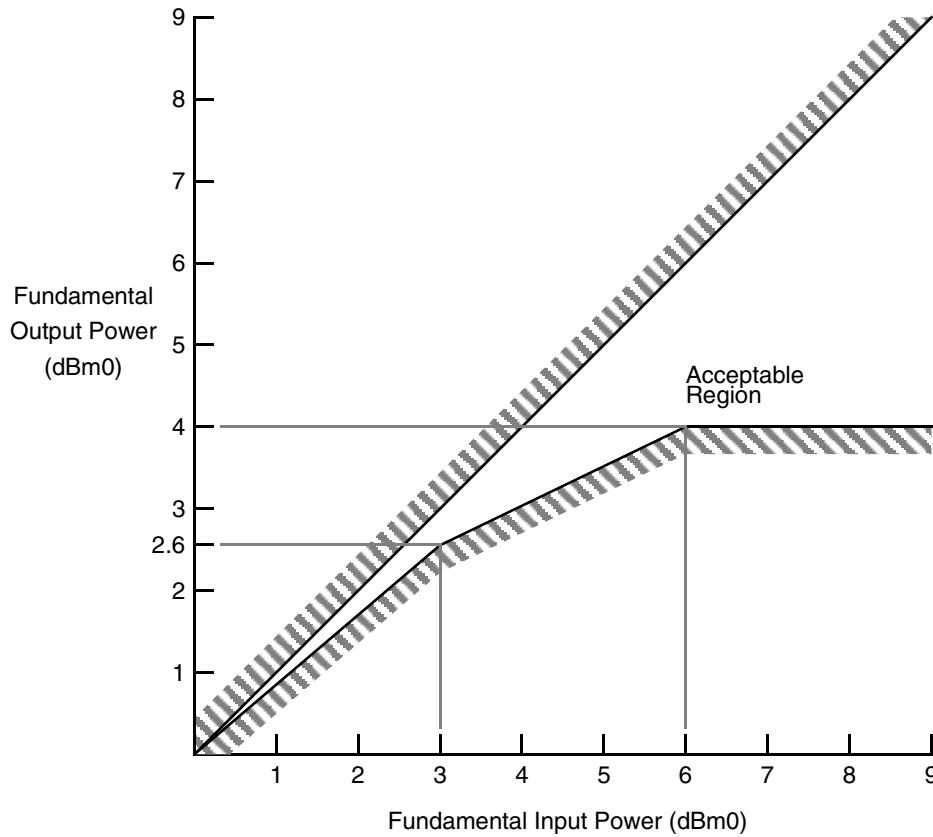

Figure 6. Spurious Out-of-Band Signals

19256A-013

Overload Compression

Figure 7 shows the acceptable region of operation for input signal levels above the reference input power (0 dBm0). The conditions for this figure are: (1) $1.2 \text{ dB} < G_X \leq 12 \text{ dB}$; (2) $-12 \text{ dB} \leq G_R < -1.2 \text{ dB}$; (3) PCM output connected to PCM input; and (4) measurement analog-to-analog.



19256A-014

Figure 7. A/A Overload Compression

SWITCHING CHARACTERISTICS over operating range (unless otherwise noted)

Min and max values are valid for all digital outputs with a 150 pF load, except CD1–C5 with a 30 pF load.

Microprocessor Interface

No.	Symbol	Parameter	Min	Typ	Max	Units	Note
1	t_{DCY}	Data clock period	244			ns	
2	t_{DCH}	Data clock High pulse width	97				
3	t_{DCL}	Data clock Low pulse width	97				
4	t_{DCR}	Rise time of clock			25		
5	t_{DCF}	Fall time of clock			25		
6	t_{ICSS}	Chip select setup time, Input state	70		$t_{DCY} - 10$		
7	t_{ICSH}	Chip select hold time, Input state	0		$t_{DCH} - 20$		
8	t_{ICSL}	Chip select pulse width, Input state		$8t_{DCY}$			
9	t_{ICSO}	Chip select off time, Input state	2.5			μs	1
10	t_{IDS}	Input data setup time	30			ns	
11	t_{IDH}	Input data hold time	30				
12	t_{OLH}	SLIC output latch valid			1000		
13	t_{OCSS}	Chip select setup time, Output state	70		$t_{DCY} - 10$		
14	$t_{OC SH}$	Chip select hold time, Output state	0		$t_{DCH} - 20$		
15	$t_{OC SL}$	Chip select pulse width, Output state		$8t_{DCY}$			
16	$t_{OC SO}$	Chip select off time, Output state	2.5			μs	1
17	t_{ODD}	Output data turn on delay			50	ns	2
18	t_{ODH}	Output data hold time	0				
19	t_{ODOF}	Output data turn off delay			50		
20	t_{ODC}	Output data valid	0		50		
21	t_{RST}	Reset pulse width	50			μs	

PCM Interface

PCLK not to exceed 8.192 MHz.

Pull-up resistors of 360 Ω are attached to \overline{TSCA} and \overline{TSCB} .

No.	Symbol	Parameter	Min	Typ	Max	Units	Note	
22	t_{PCY}	PCM clock period	122			ns	3	
23	t_{PCH}	PCM clock High pulse width	48					
24	t_{PCL}	PCM clock Low pulse width	48					
25	t_{PCF}	Fall time of clock			15			
26	t_{PCR}	Rise time of clock			15			
27	t_{FSS}	FS setup time	25		$t_{PCY} - 50$			
28	t_{FSH}	FS hold time	50					
30	t_{TSD}	Delay to \overline{TSC} valid	5		80			4
31	t_{TSO}	Delay to \overline{TSC} off	5		80			4,5
32	t_{DXD}	PCM data output delay	5		70			
33	t_{DXH}	PCM data output hold time	5		70			
34	t_{DXZ}	PCM data output delay to High-Z	5		70			6
35	t_{DRS}	PCM data input setup time	25					
36	t_{DRH}	PCM data input hold time	5					

Master Clock

No.	Symbol	Parameter	Min	Typ	Max	Units	Note
37	A_{MCY}	Master clock accuracy	-100		+100	ppM	
38	t_{MCR}	Rise time of clock			15	ns	
39	t_{MCF}	Fall time of clock			15		
40	t_{MCH}	MCLK High pulse width	48				
41	t_{MCL}	MCLK Low pulse width	48				

Auxiliary Output Clocks

No.	Symbol	Parameter	Min	Typ	Max	Units	Note
42	f_{CHP}	Chopper clock frequency CHP = 0 CHP = 1		256 292.57		kHz	
43	f_{E1}	E1 output frequency (CMODE = EE1 = 1)		4.923			
44	t_{E1}	E1 pulse width (CMODE = EE1 = 1)		31.25		μ s	

Notes:

- If $CFAIL = 1$ (Command 23), GX , GR , Z , $B1$, X , R , and $B2$ coefficients must not be written or read without first deactivating all channels or switching them to default coefficients; otherwise, a chip select off time of 25μ s is required. If the low power state ($LPM = 1$, Command 14) is selected and $MCLK$ is also lost, this minimum chip select off time increases to 75μ s.
- The first data bit is enabled on the falling edge of \overline{CS} or on the falling edge of $DCLK$, whichever occurs last.
- The PCM clock frequency must be an integer multiple of the frame sync frequency. The maximum allowable PCM clock frequency is 8.192 MHz. The actual PCM clock rate is dependent on the number of channels allocated within a frame. The minimum clock frequency is 128 kHz in Companded state and 256 kHz in Linear state, PCM Signaling state. The minimum PCM clock rates should be doubled for parts with only one PCM highway in order to allow simultaneous access to all four channels.
- \overline{TSC} is delayed from FS by a typical value of $N \cdot t_{PCY}$, where N is the value stored in the time/clock-slot register.
- t_{TSO} is defined as the time at which the output achieves the Open Circuit state.
- There is a special conflict detection circuitry that will prevent high-power dissipation from occurring when the DXA or DXB pins of two $QSLAC$ devices are tied together and one $QSLAC$ device starts to transmit before the other has gone into a High-impedance state.

SWITCHING WAVEFORMS

Input and Output Waveforms for AC Tests

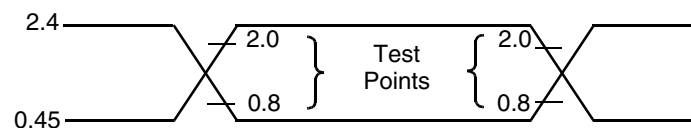

19256A-015

Master Clock Timing

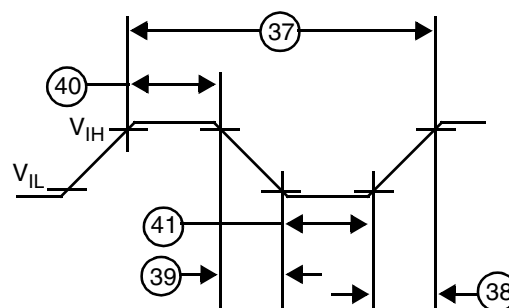

19256A-016

Microprocessor Interface (Input Mode)

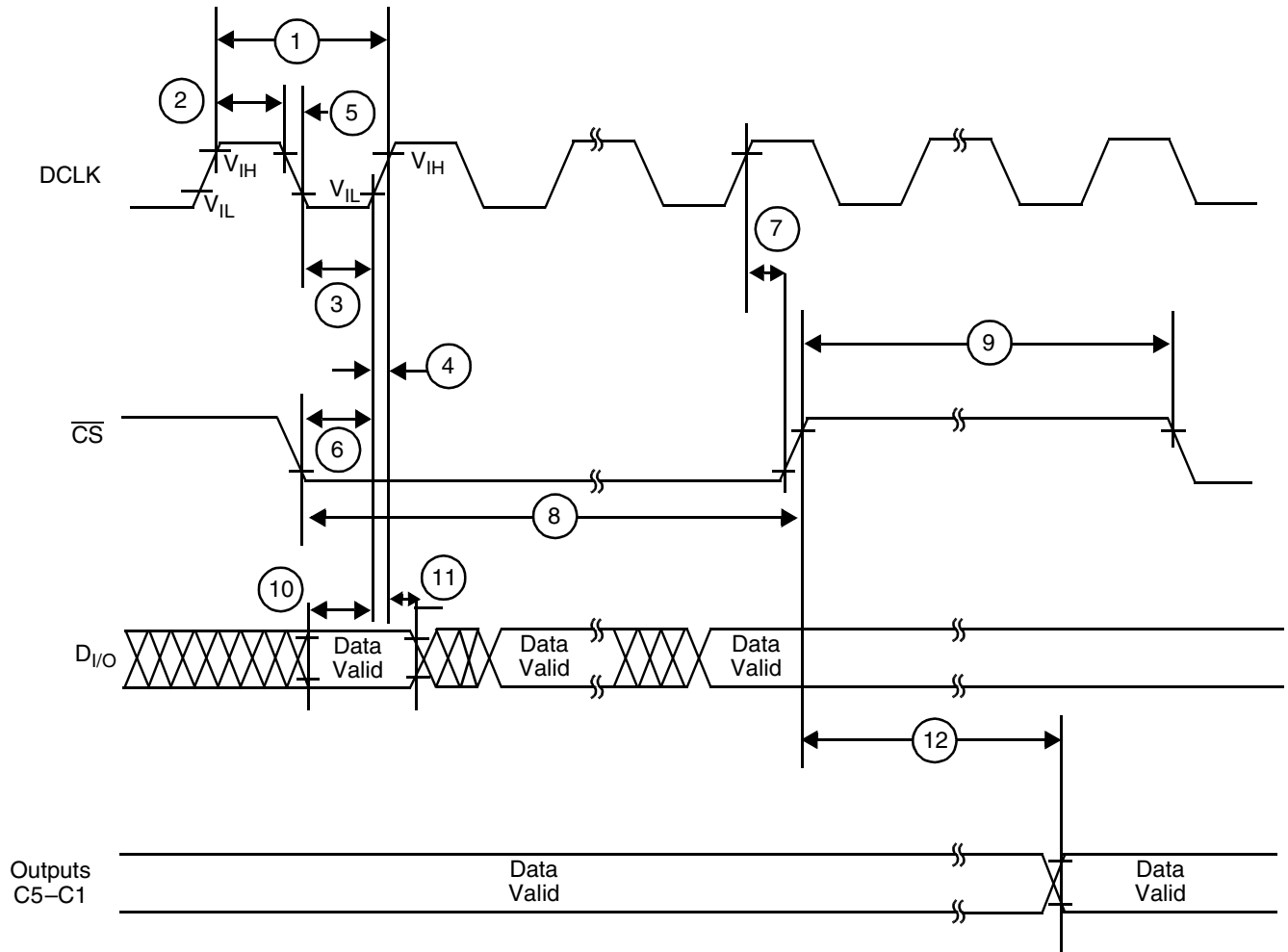

21108-019

Microprocessor Interface (Output Mode)

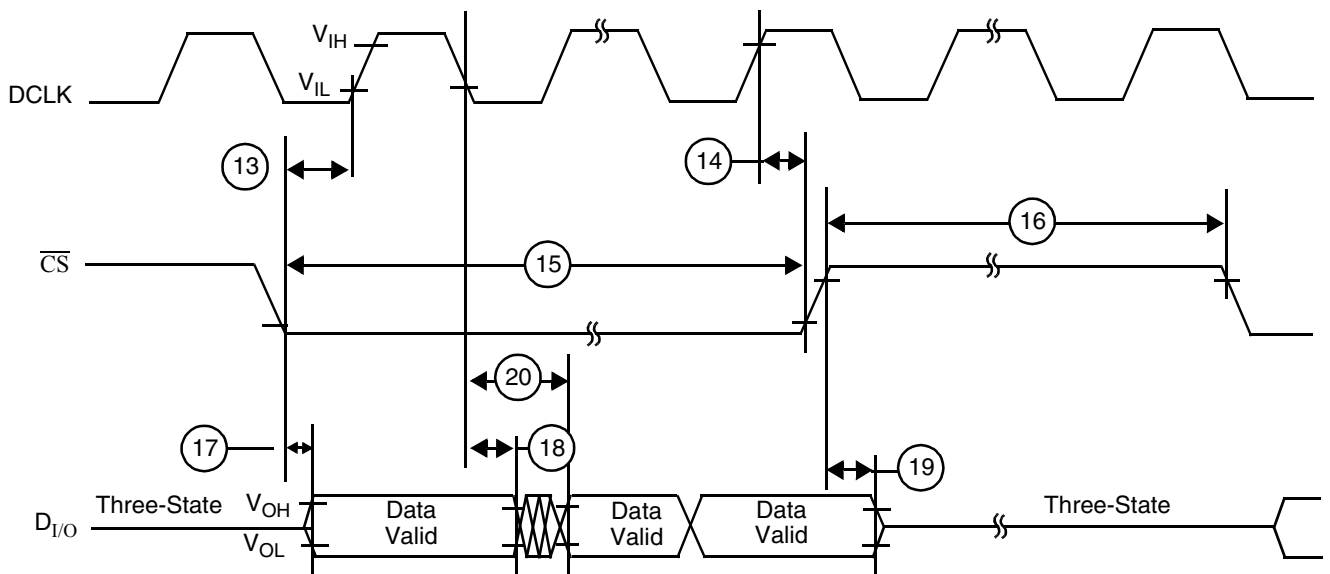

21108A-020

PCM Highway Timing for XE = 0 (Transmit on Negative PCLK Edge)

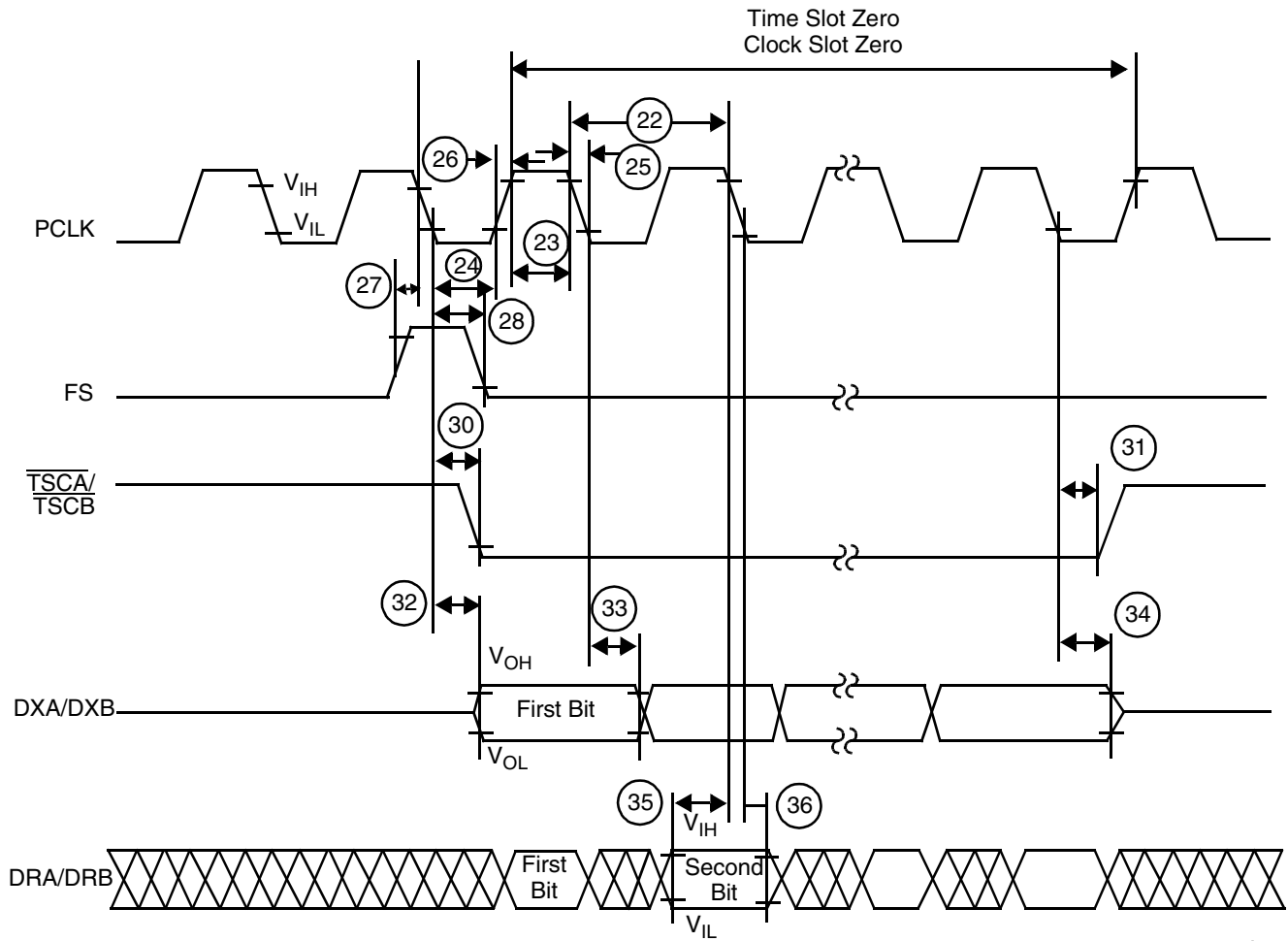

21108A-021

PCM Highway Timing for XE = 1 (Transmit on Positive PCLK Edge)

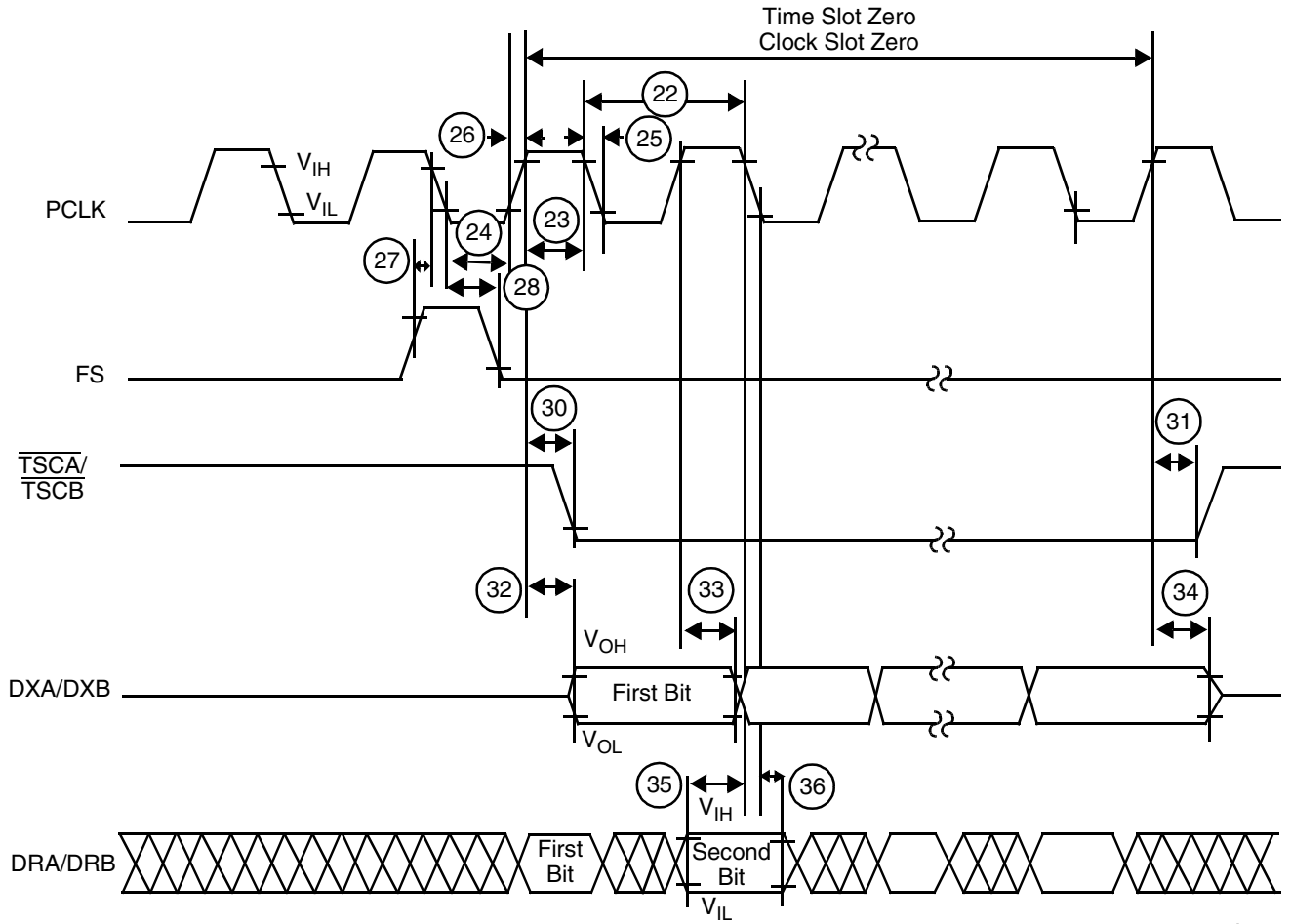

21108A-022

OPERATING THE QSLAC DEVICE

The following sections describe the operation of the four independent channels of the QSLAC device. The description is valid for channel 1, 2, 3, or 4; consequently, the channel subscripts have been dropped. For example, VOUT refers to either VOUT1, VOUT2, VOUT3, or VOUT4.

Power-Up Sequence

The recommended QSLAC device power-up sequence is to apply:

1. VCC and ground
2. Signal connections and Low on RST
3. High on RST

The software initialization should then include:

1. Wait 1 ms.
2. Select master clock frequency and source (Commands 12 and 13). This should turn off the CFAIL bit (Command 23) within 400 μ s. While the CFAIL bit is on, normal programming can proceed, but no channels should be activated.
3. Program filter coefficients and other parameters as required.
4. Activate (Command 5).

If the power supply (VCCD) falls below approximately 1.0 V, the device is reset and will require complete reprogramming with the above sequence. A reset may be initiated by connection of a logic Low to the $\overline{\text{RST}}$ pin, or if chip select ($\overline{\text{CS}}$) is held low for 16 rising edges of DCLK, a hardware reset is generated when CS returns high. The $\overline{\text{RST}}$ pin may be tied to VCCD if it is not used in the system.

Channel Enable Register

A channel enable register has been implemented in the QSLAC device in order to reduce the effort required to address individual or multiple channels of the QSLAC device. The register is written using MPI Command 14. Each bit of the register is assigned to one unique channel, bit 0 for channel 1, bit 1 for channel 2, bit 2 for channel 3, and bit 3 for channel 4. The channel or channels are enabled when their corresponding enable bits are High. All enabled channels will receive the data written to the QSLAC device. This enables a Broadcast state (all channels enabled) to be implemented simply and efficiently, and

multiple channel addressing is accomplished without increasing the number of I/O pins on the device. The Broadcast state can be further enhanced by providing the ability to select many chips at once; however, care must be taken never to enable more than one chip in the Read state. This can lead to an internal bus contention, in which excess power is dissipated. (Bus contention will not damage the device.) Most control commands defined for the DSLAC device are compatible with the QSLAC device, thereby minimizing the impact to existing system software.

SLIC Control and Data Lines

The QSLAC device has up to five SLIC digital interface pins per channel (CD1–C5). Each of these pins can be programmed as either an input or an output using the I/O Direction register (Commands 22 and 23) (see Figure 9). The output latches can be written with Command 20; however, only those bits programmed as outputs will actually drive the pins. The inputs can be read with Command 21. If a pin is programmed as an output, the data read from it will be the contents of the output latch. It is recommended that any of the SLIC input/output data points, which are to be programmed as outputs, be written to their desired state via Command 21 before writing the data which configures them as outputs with the I/O direction register Command 22. This ensures that when the output is activated, it is already in the correct state, and will prevent unwanted data from being driven from the SLIC output pins.

Clock Mode Operation

The QSLAC device operates with multiple clock signals. The master clock (MCLK) is used for internal timing including operation of the digital signal processing and may be derived from either the MCLK or PCLK source. The allowed frequencies are listed under Commands 12 and 13.

The PCM clock (PCLK) is used for PCM timing and is an integer multiple of the frame sync frequency. The internal device clock (MCLK) can be optionally derived from the PCLK source by setting the CMODE bit (bit 4, Commands 12 and 13, 46/47h) to one. In this mode, the MCLK/E1 pin is free to be used as an E1 signal output. Clock mode options and E1 output functions are shown in Figure 8.

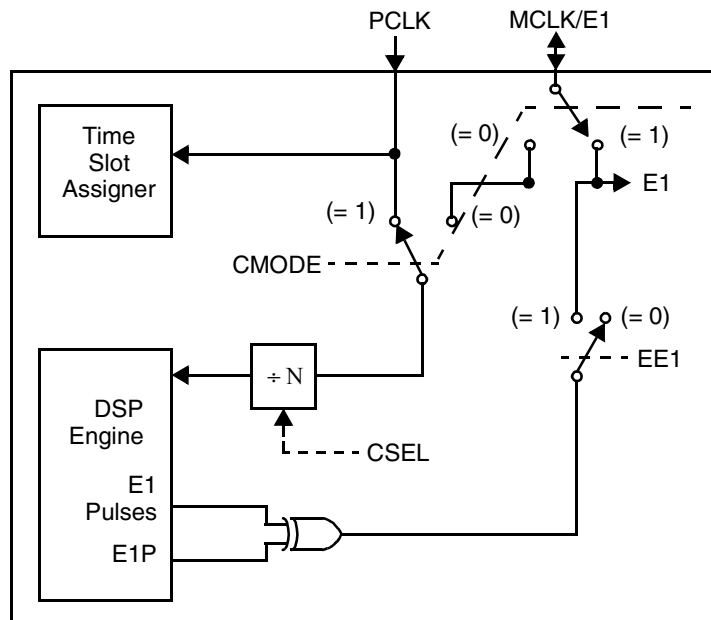

Notes:

1. CMODE = Command 12, 13 Bit 4
2. CSEL = Command 12, 13 Bits 0–3
3. EE1 = Command 45, 46 Bit 7
4. E1P = Command 45, 46 Bit 6

Figure 8. Clock Mode Option

E1 Multiplex Operation

The QSLAC device can multiplex input data from the CD1 SLIC I/O pin into two separate status bits per channel (CD1 and CD1B bits in the SLIC Input/Output register, Commands 52/53h, and CDA and CDB bits in the Real Time Data register, Commands 4D/4Fh) using the E1 multiplex mode. This multiplex mode provides the means to accommodate dual detect states when connected to an Legerity SLIC device, which also supports ground-key detection in addition to loop detect. Legerity SLICs that support ground-key detect use their E1 pin as an input to switch the SLIC's single detector (DET) output between internal loop detect or ground-key detect comparators. Using the E1 multiplex mode, a single QSLAC device can monitor both loop detect and ground-key detect states of all four connected SLICs without additional hardware. Although normally used for ground key detect, this multiplex function can also be used for monitoring other signal states.

The E1 multiplex mode is selected by setting the EE1 bit (bit 7, Command C8/C9h) and CMODE bit (bit 4, Command 46/47h) in the QSLAC device. The CMODE bit must be selected (CMODE=1) for the master clock to be derived from PCLK so that the MCLK/E1 pin can be used as an output for the E1 signal. The multiplex mode is then turned on by setting the EE1 bit. With the

E1 multiplex mode enabled, the QSLAC device generates the E1 output signal. This signal is a 31.25 μ s (1/32 kHz) duration pulse occurring at a 4.923 kHz (64 kHz/13) rate. The polarity of this E1 output is selected by the E1P bit (bit 6, Command C8/C9h) allowing this multiplex mode to accommodate all SLICs regardless of their E1 high/low logic definition.

Figure 9 shows the SLIC Input/Output register, I/O pins, E1 multiplex hardware operation for one QSLAC device channel. It also shows the operation of the Real Time Register. The QSLAC device E1 output signal connects directly to the E1 inputs of all four connected SLICs and is used by those SLICs to select an internal comparator to route to the SLIC's DET output. This E1 signal is also used internally by the QSLAC device for controlling the multiplex operation and timing.

The CD1 and CD1B bits of the SLIC Input/Output register are isolated from the CD1 pin by transparent latches. When the E1 pulse is off, the CD1 pin data is routed directly to the CD1 bit of the SLIC I/O register and changes to the CD1B bit of that register are disabled by its own latch. When E1 pulses on, the CD1 latch holds the last CD1 state in its register. At the same time, the CD1B latch is enabled, which allows CD1 pin data to be routed directly to the CD1B bit.

Therefore, during this multiplexing, the CD1 bit always has loop-detect status and the CD1B bit always has ground-key detect status.

This multiplexing state changes almost instantaneously within the QSLAC device but the SLIC device may require a slightly longer time period to respond to this detect state change before its DET output settles and becomes valid. To accommodate this delay difference, the internal signals within the QSLAC device are isolated by 15.625 μ s before allowing any change to the CD1 bit and CD1B bit latches. This operation is further described by the E1

multiplex timing diagram in Figure 9. In this timing diagram, the E1 signal represents the actual signal presented to the E1 output pin. The GK Enable pulse allows CD1 pin data to be routed through the CD1B latch. The LD Enable pulse allows CD1 pin data to be routed through the CD1 latch. The uncertain states of the SLIC's DET output, and the masked times where that DET data is ignored are shown in this timing diagram. Using this isolation of masked times, the CD1 and CD1B registers are guaranteed to contain accurate representations of the SLIC detector output.

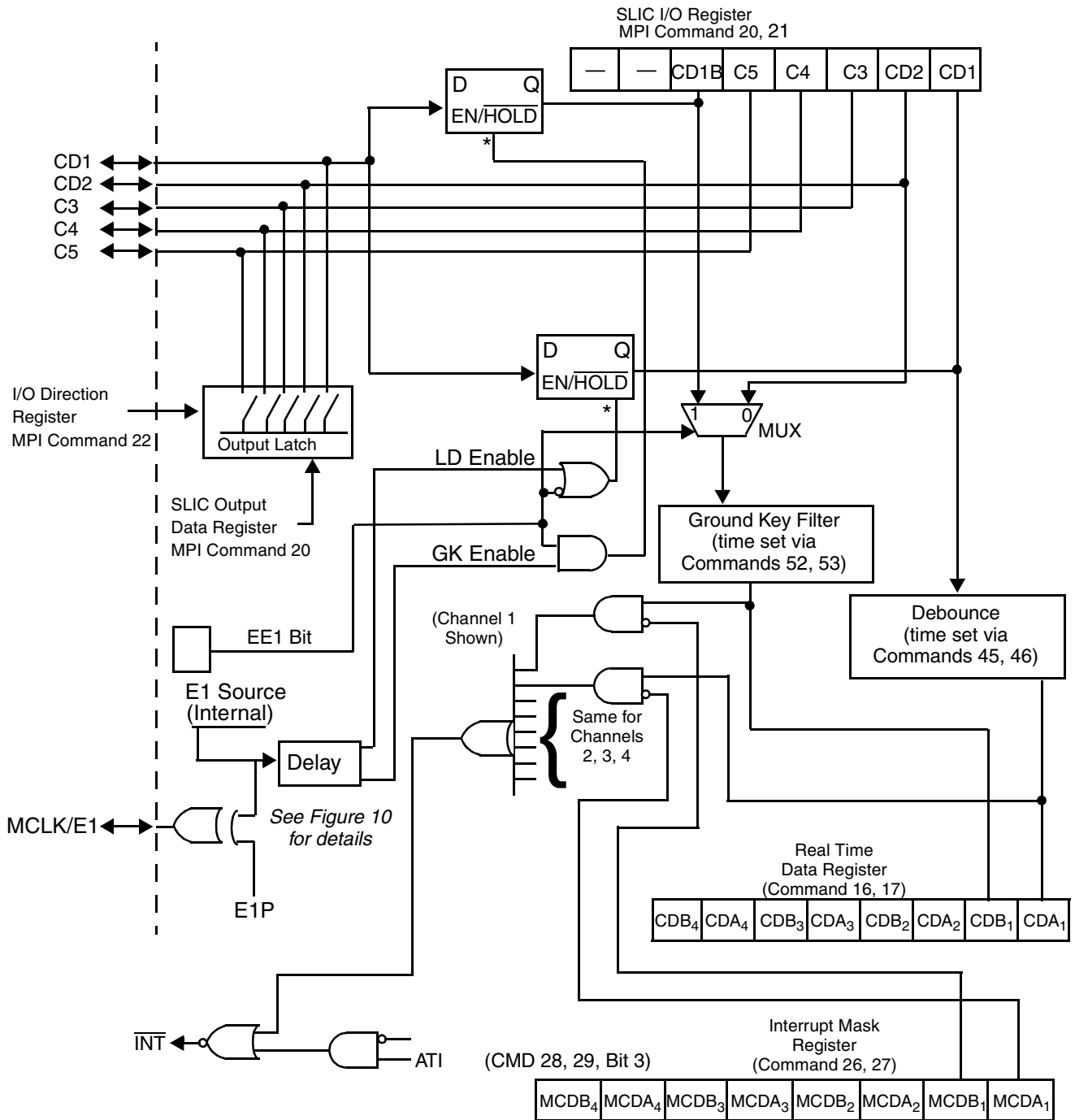

Note:

* Transparent latches: When enable input is high, Q output follows D input. When enable input goes low, Q output is latched at last state.

Figure 9. SLIC I/O, E1 Multiplex and Real-Time Data Register Operation

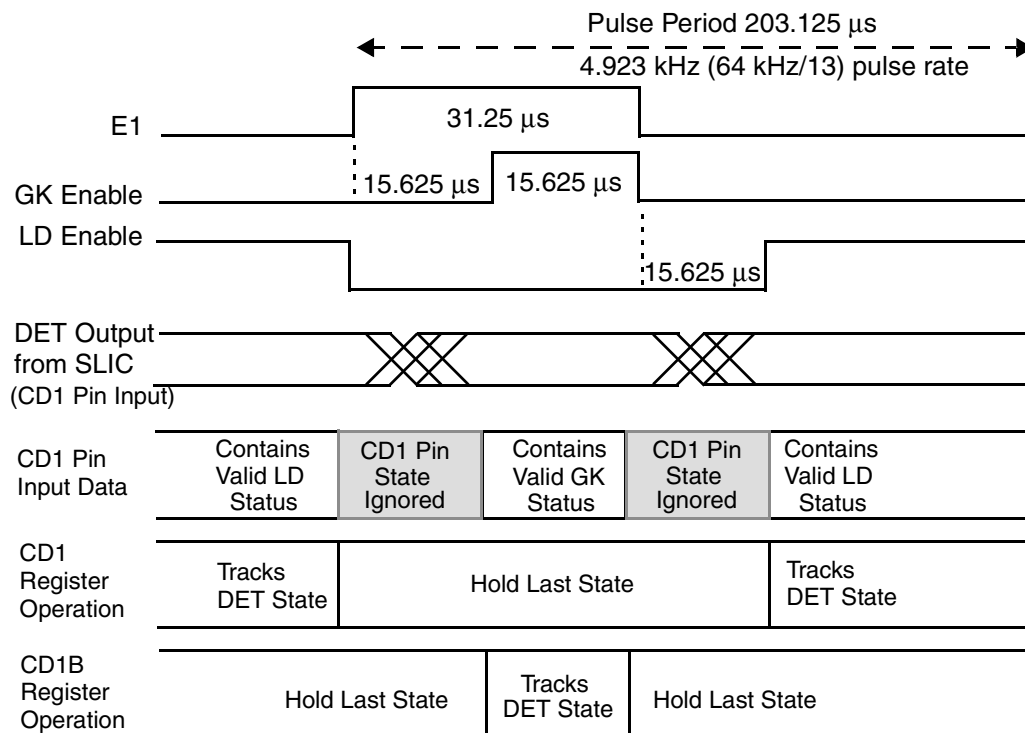

Figure 10. E1 Multiplex Internal Timing

Debounce Filters Operation

Each channel is equipped with two debounce filter circuits to buffer the logic status of the CD1 and CD2/CD1B bits of the SLIC I/O Data Register (Commands 20 and 21, 52/53h) before providing filtered bit's outputs to the Real-Time Data Register (Commands 16 and 17, 4D/4Fh). One filter is used only for the CD1 bit. The other filter acts upon either the CD1B bit if E1 multiplexing is enabled, or on the CD2 bit if the multiplexing is not enabled.

The CD1 bit normally contains SLIC loop detect status. The CD1 debouncing time is programmable with the Debounce Time Register (Commands 45 and 46, C8/C9h), and even though each channel has its own filter, the programmed value is common to all four channels. This debounce filter is initially clocked at the frame sync rate of 125 μs, and any occurrence of changing data at this sample rate resets a programmable counter. This programmable counter is clocked at a 1 ms rate, and the programmed count value of 0 to 15 ms, as defined by the Debounce Time Register, must be reached before updating the CDA bit of the Real Time Data register with the CD1 state. Refer to Figure 11a for this filter's operation.

The ground-key filter (Figure 11b) provides a buffering of the signal, normally ground key detect, which appears in the CDB bit of the Real Time Data Register. Each channel has its own filter, and each filter's time can be individually programmed. The input to the filter comes from either the CD2 bit of the SLIC I/O Data Register (Command 20 and 21, 52/53h), when E1

multiplexing is not enabled, or from the CD1B bit of that register when E1 multiplexing is enabled. The feature debounces ground-key signals before passing them to the Real Time Data Register, although signals other than ground-key status can be routed to the CD2 pin and then through the registers.

The ground-key debounce filter operates as a duty-cycle detector and consists of an up/down counter which can range in value between 0 and 6. This six-state counter is clocked by the GK timer at the sampling period of 1–15 ms, as programmed by the value of the four GK bits (GK3, GK2, GK1, GK0) of the Ground-Key Filter Data register (Commands 52 and 53, E8/E9h). This sampling period clocks the counter, which buffers the CD2/CD1B bit's status before it is valid for presenting to the CDB bit of the Real Time Data Register. When the sampled value of the ground-key (or CD2) input is high, the counter is incremented by each clock pulse. When the sampled value is low, the counter is decremented. Once the counter increments to its maximum value of 6, it sets a latch whose output is routed to the corresponding CDB bit. If the counter decrements to its minimum value of 0, this latch is cleared and the output bit is set to zero. All other times, the latch (and the CDB status) remains in its previous state without change. It therefore takes at least six consecutive GK clocks with the debounce input remaining at the same state to effect an output change. If the GK bit value is set to zero, the buffering is bypassed and the input status is passed directly to CDB.

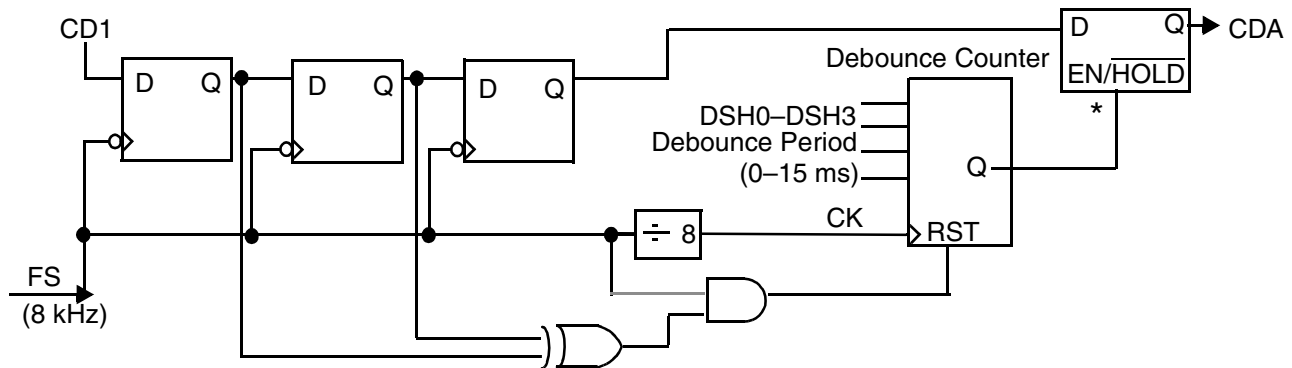

Notes:

* Transparent latch: Output follows input when EN is high; output holds last state when EN is low
 Debounce Counter: Output goes high after counting to programmed (DSH) number of 1 ms clocks; Counter is reset for CD1 input changes at 125 μ s sample period.
 DSH0-DSH3 programmed value is common for all 4 channels, but debounce counter is separate per channel

a. Loop Detect Debounce Filter

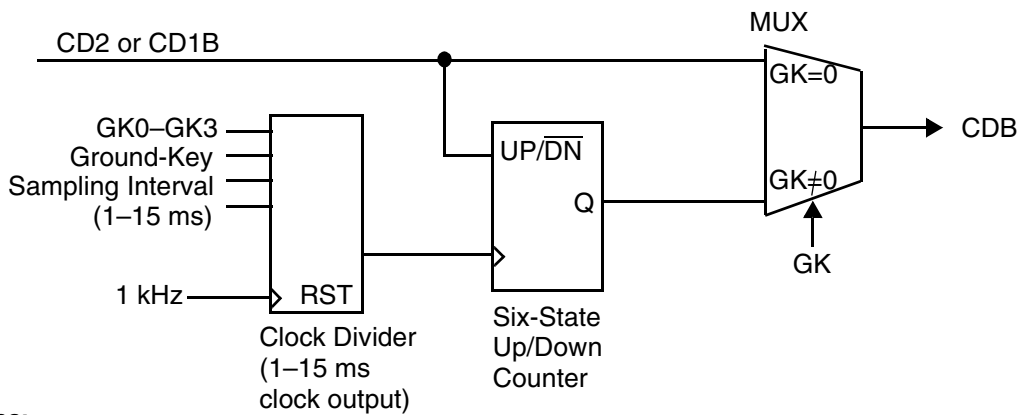

Notes:

Programmed value of GK0-GK3 determines clock rate (1-15 ms) of six-state counter.
 If GK value = 0, counter is bypassed and no buffering occurs.
 Six-state up/down counter: Counts up when input is high; counts down when input is low. Output goes and stays high when maximum count is reached; output goes and stays low when counts down to zero.

b. Ground-Key Filter

Figure 11. MPI Real-Time Data Register or GCI Upstream SC Channel Data

Real-Time Data Register Operation

To obtain time-critical data such as off/on-hook and ring trip information from the SLIC with a minimum of processor time and effort, the QSLAC device contains an 8-bit Real Time Data register. This register contains CDA and CDB bits from all four channels. The CDA bit for each channel is a debounced version of the CD1 input. The CDA bit is normally used for switchhook. The CDB bit for each channel normally contains the CD2 input bit; however, if the E1 multiplex operation is enabled, the CDB bit will contain the debounced value of the CD1B bit. CD1 and CD2 can be assigned to off-hook, ring trip, ground key signals, or other signals. Frame sync is needed for the debounce and the ground key signals. If Frame sync is not provided, the real-time register will not work. The register is read using MPI Commands 16 and 17 (4D/4Fh), and may be read at any time regardless of the state of the Channel Enable Register. This allows off/on-hook, ring trip, or ground key information for all four channels to be obtained from the QSLAC device with one read operation versus one read per channel. If these data bits are not used for supervision information, they can be accessed on an individual channel basis in the same way as C3–C5; however, CD1 and CD1B will not be debounced.

Interrupt

In addition to the Real Time Data register, an interrupt signal has been implemented in the QSLAC device. The interrupt signal is an active Low output signal which pulls Low whenever the unmasked CD bits change state (Low to High or High to Low); or whenever the transmit PCM data changes on a channel in which the Arm Transmit Interrupt (ATI) bit is on. The interrupt control is shown in Figure 9. The interrupt remains Low until the appropriate register is read. This output can be programmed as TTL or open drain. When an interrupt is generated, all of the unmasked bits in the Real Time Data register latch and remain latched until the interrupt is cleared. The interrupt is cleared by reading the register with Command 17, by writing to the interrupt mask register (Command 26), or by a reset. If any of the inputs to the unmasked bits in the Real Time Data register are different from the register bits when the interrupt is cleared, a new interrupt is immediately generated with the new data latched into the Real Time Data register. For this reason, the interrupt logic in the controller should be level-sensitive rather than edge-sensitive.

Interrupt Mask Register

The Real Time Data register data bits can be masked from causing an interrupt to the processor using the interrupt mask register. The mask register can be written or read via the MPI Commands 26 and 27.

Active State

Each channel of the QSLAC device can operate in either the Active (operational) or Inactive (standby) state. In the Active state, individual channels of the QSLAC device can transmit and receive PCM or linear data and analog information. The Active state is required when a telephone call is in progress. The activate command (MPI Command 5), puts the selected channel(s) into this state (see channel enable register). Bringing a channel of the QSLAC device into the Active state is only possible through the MPI.

Inactive State

All channels of the QSLAC device are forced into the Inactive (standby) state by a power-up or hardware reset. Individual channels can be programmed into this state by the deactivate command (Command 1) or by the software reset command (Command 2). Power is disconnected from all nonessential circuitry while the MPI remains active to receive commands. The analog output is tied to VREF through a resistor whose value depends on the VMODE bit. All circuits that contain programmed information retain their data in the Inactive state.

Low Power State

If the Low Power state is turned on by setting LPM = 1 (Command 14), the internal clock speed substantially reduces when all four channels are deactivated. When this happens, the CFAIL bit is set to 1, and if MCLK also is lost, the microprocessor interface requires a minimum of 75 ms off time between commands.

Chopper Clock

On the Am79Q02JC there is a chopper clock output to drive the switching regulator on some Legerity SLICs. The clock frequency is selectable as 256 or 292.57 kHz by the CHP bit (Command 12). The chopper output must be turned on with the ECH bit (Command 45).

Reset States

The QSLAC device can be reset by application of power, by an active Low on the hardware Reset pin ($\overline{\text{RST}}$), by a hardware reset command, or by $\overline{\text{CS}}$ Low for 16 or more rising edges of DCLK. This resets the QSLAC device to the following state:

1. A-law companding is selected.
2. Default B, X, R, and Z filter values are selected and the AISN is set to zero.
3. Default digital gain blocks (GX, GR) are selected. The analog gains, AX and AR, are set to 0 dB.
4. SLIC I/Os (CD1–C5) are set to the Input state.
5. All of the test states in the Operating Conditions register are turned off (0's).
6. All four channels are in the Inactive (standby) state.

7. Transmit time slots and receive time slots are set to 0, 1, 2, and 3 for channels 1, 2, 3, and 4, respectively. The clock slots are set to 0, with transmit on the negative edge.
8. DXA port is selected for all channels.
9. DRA port is selected for all channels.
10. The master clock frequency selected is 8.192 MHz and is programmed to come from PCLK.
11. All four channels are selected in the Channel Enable register.
12. Any pending interrupts are cleared, all interrupts are masked, and the Interrupt Output state is set to open drain.
13. The supervision debounce time is set to 8 ms.
14. The previously programmed B, Z, X, R, GX, and GR filters are unchanged.
15. The chopper clock frequency is set to 256 kHz but the chopper clock is turned off.

16. The E1 Multiplex state is turned off and the polarity is set for high going pulses.
17. No signalling on the PCM highway.

SIGNAL PROCESSING

Overview of Digital Filters

Several of the blocks in the signal processing section are user programmable. These allow the user to optimize the performance of the QSLAC device for the system. Figure 12 shows the QSLAC device signal processing and indicates the programmable blocks.

The advantages of digital filters are:

- High reliability
- No drift with time or temperature
- Unit-to-unit repeatability
- Superior transmission performance
- Flexibility
- Maximum possible bandwidth for V.34 modems

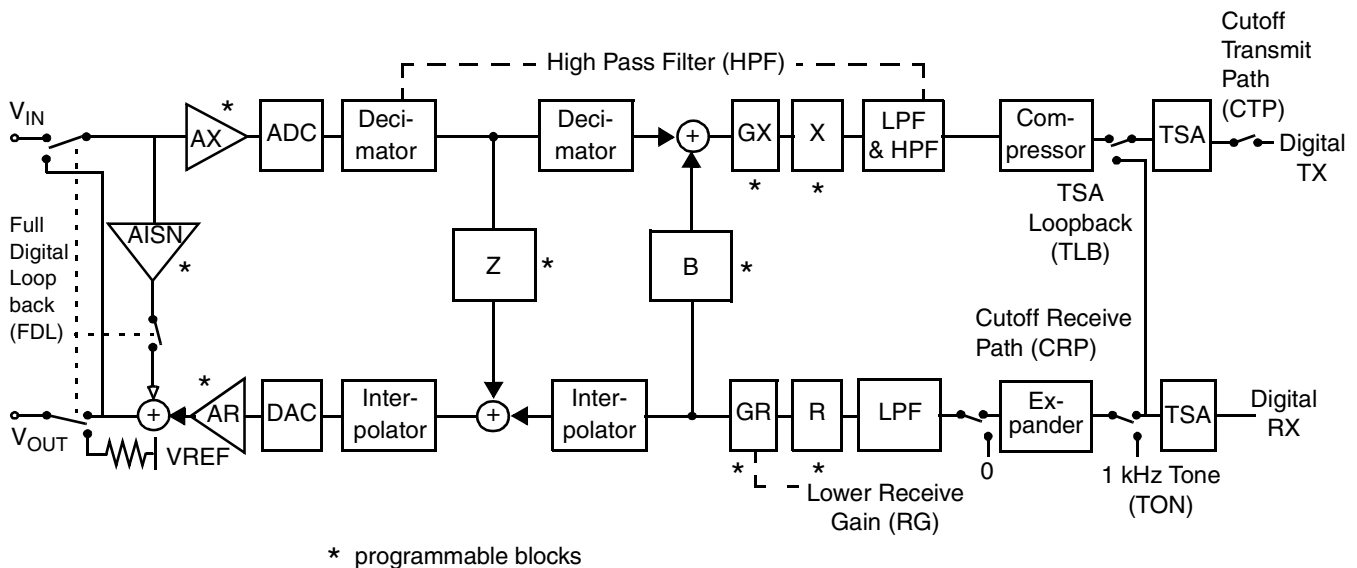

21108-027

Figure 12. QSLAC Device Block Diagram

Two-Wire Impedance Matching

Two feedback paths on the QSLAC device synthesize the two-wire input impedance of the SLIC by providing a programmable feedback path from VIN to VOUT. The Analog Impedance Scaling Network (AISN) is a programmable analog gain of -0.9375 to $+0.9375$ from VIN to VOUT. The Z filter is a programmable digital filter providing an additional path and programming flexibility over the AISN in modifying the transfer function from VIN to VOUT. Together, the AISN and the Z-Filter enable the user to synthesize virtually all required SLIC input impedances.

Frequency Response Correction and Equalization

The QSLAC device contains programmable filters in the receive (R) and transmit (X) directions that may be programmed for line equalization and to correct any attenuation distortion caused by the Z filter.

Transhybrid Balancing

The QSLAC device's programmable B filter is used to adjust transhybrid balance. The filter has a single pole IIR section (BIIR) and an eight-tap FIR section (BFIR), both operating at 16 kHz.

Gain Adjustment

The QSLAC device's transmit path has two programmable gain blocks. Gain block AX is an analog gain of 0 dB or 6.02 dB (unity gain or gain of 2.0), located immediately before the A/D converter. GX is a digital gain block that is programmable from 0 dB to +12 dB, with a worst-case step size of 0.1 dB for gain settings below +10 dB, and a worst-case step size of 0.3 dB for gain settings above +10 dB. The filters provide a net gain in the range of 0 dB to 18 dB.

The QSLAC device receive path has two programmable loss blocks. GR is a digital loss block that is programmable from 0 dB to 12 dB, with a worst-case step size of 0.1 dB. Loss block AR is an analog loss of 0 dB or 6.02 dB (unity gain or gain of 0.5), located immediately after the D/A converter. This provides a net loss in the range of 0 dB to 18 dB.

An additional 6 dB attenuation is provided as part of GR, which can be inserted by setting the RG bit of Command 70/71h. This allows writing of a single bit to introduce 6 dB of attenuation into the receive path without having to reprogram GR. This 6 dB loss is implemented as part of GR and the total receive path attenuation must remain in the specified 0 to -12 dB range. If the RG bit is set, the programmed value of GR must not introduce more than an additional 6 dB attenuation.

Transmit Signal Processing

In the transmit path (A/D), the analog input signal (VIN) is A/D converted, filtered, companded (for A-law or μ -law), and made available to the PCM highway in A-law, μ -law, or linear form. If linear form is selected, the 16-bit data will be transmitted in two consecutive time slots starting at the programmed time slot. The signal processor contains an ALU, RAM, ROM, and control logic to implement the filter sections. The B, X, and GX blocks are user-programmable digital filter sections with coefficients stored in the coefficient RAM, while AX is an analog amplifier that can be programmed for 0 dB or 6.02 dB gain. The B, X, and GX filters can also be operated from an alternate set of default coefficients stored in ROM (Commands 24 and 25).

The decimator reduces the high input sampling rate to 16 kHz for input to the B, GX, and X filters. The X filter is a six-tap FIR section which is part of the frequency response correction network. The B filter operates on samples from the receive signal path in order to provide transhybrid balancing in the loop. The high-pass filter rejects low frequencies such as 50 Hz or 60 Hz, and may be disabled.

Transmit PCM Interface

The transmit PCM interface transmits a 16-bit linear code (when programmed) or an 8-bit compressed code from the digital A-law/ μ -law compressor. Transmit logic controls the transmission of data onto the PCM highway through output port selection and time/clock slot control circuitry. The linear data requires two consecutive time slots, while a single time slot is required for A-law/ μ -law data.

In the PCM Signaling state (SMODE = 1), the transmit time slot following the A-law or μ -law data is used for signaling information. The two time slots form a single 16-bit data block.

The frame sync (FS) pulse identifies time slot 0 of the transmit frame and all channels (time slots) are referenced to it. The logic contains user-programmable Transmit Time Slot and Transmit Clock Slot registers.

The Time Slot register is 7 bits wide and allows up to 128 8-bit channels (using a PCLK of 8.192 MHz) in each frame. This feature allows any clock frequency between 128 kHz and 8.192 MHz (2 to 128 channels) in a system. The data is transmitted in bytes, with the most significant bit first.

The Clock Slot register is 3 bits wide and may be programmed to offset the time slot assignment by 0 to 7 PCLK periods to eliminate any clock skew in the system. An exception occurs when division of the PCLK frequency by 64 kHz produces a nonzero remainder, R, and when the transmit clock slot is greater than R. In that case, the R-bit fractional time

slot after the last full time slot in the frame will contain random information and will have the TSC output turned on. For example, if the PCLK frequency is 1.544 MHz ($R = 1$) and the transmit clock slot is greater than 1, the 1-bit fractional time slot after the last full time slot in the frame will contain random information, and the TSC output will remain active during the fractional time slot. In such cases, problems can be avoided by not using the last time slot.

The PCM data may be user programmed for output onto either the DXA or DXB port or both ports simultaneously. Correspondingly, either \overline{TSCA} or \overline{TSCB} or both are Low during transmission.

The DXA/DXB and $\overline{TSCA}/\overline{TSCB}$ outputs can be programmed to change either on the negative or positive edge of PCLK.

Transmit data can also be read through the microprocessor interface using Command 47.

Receive Signal Processing

In the receive path (D/A), the digital signal is expanded (for A-law or μ -law), filtered, converted to analog, and passed to the VOUT pin. The signal processor contains an ALU, RAM, ROM, and Control logic to implement the filter sections. The Z, R, and GR blocks are user-programmable filter sections with their coefficients stored in the coefficient RAM, while AR is an analog amplifier which can be programmed for a 0 dB or 6.02 dB loss. The Z, R, and GR filters can also be operated from an alternate set of default coefficients stored in ROM (Commands 24 and 25).

The low-pass filter band limits the signal. The R filter is composed of a six-tap FIR section operating at a 16 kHz sampling rate and a one-tap IIR section operating at 8 kHz. It is part of the frequency response correction network. The Analog Impedance Scaling Network (AISN) is a user-programmable gain block providing feedback from VIN to VOUT to emulate different SLIC input impedances from a single external SLIC impedance. The Z filter provides feedback from the transmit signal path to the receive path and is used to modify the effective input impedance to the system. The interpolator increases the sampling rate prior to D/A conversion.

Receive PCM Interface

The receive PCM interface logic controls the reception of data bytes from the PCM highway, transfers the data to the A-law/ μ -law expansion logic for compressed signals, and then passes the data to the receive path of the signal processor. If the data received from the PCM highway is programmed for linear code, the A-law/ μ -law expansion logic is bypassed and the data is presented to the receive path of the signal processor directly. The linear data requires two consecutive time slots, while the A-law or μ -law data requires a single time slot.

The frame sync (FS) pulse identifies time slot 0 of the receive frame, and all channels (time slots) are referenced to it. The logic contains user-programmable Receive Time Slot and Receive Clock Slot registers. The Time Slot register is 7 bits wide and allows up to 128 8-bit channels (using a PCLK of 8.192 MHz) in each frame. This feature allows any clock frequency between 128 kHz and 8.192 MHz (2 to 128 channels) in a system.

The Clock Slot register is 3 bits wide and can be programmed to offset the time slot assignment by 0 to 7 PCLK periods to eliminate any clock skews in the system. An exception occurs when division of the PCLK frequency by 64 kHz produces a nonzero remainder (R), and when the receive clock slot is greater than R . In that case, the last full receive time slot in the frame is not usable. If the PCLK frequency is 1.544 MHz ($R=1/8$, or 1 clock slot within a time slot), the receive clock slot can be only 0 or 1 if the last time slot is to be used. The PCM data can be programmed for input from the DRA or DRB port.

Analog Impedance Scaling Network (AISN)

The AISN is in the QSLAC device to scale the value of the external SLIC impedance. Scaling this external impedance with the AISN (along with the Z filter) allows matching of many different line conditions using a single impedance value. Linecards can meet many different specifications without any hardware changes.

The AISN is a programmable transfer function connected from VIN to VOUT for each QSLAC device channel. The AISN transfer function alters the input impedance of the SLIC device to a new value (Z_{IN}):

$$Z_{IN} = ZSL \cdot (1 - G_{44} \cdot h_{AISN}) / (1 - G_{440} \cdot h_{AISN})$$

where G_{440} is the SLIC echo gain into an open circuit, G_{44} is the SLIC echo gain into a short circuit, and ZSL is the SLIC input impedance without the QSLAC device.

The gain can be varied from -0.9375 to $+0.9375$ in 31 steps of 0.0625. The AISN gain is determined by the following equation:

$$h_{AISN} = 0.0625 \left[\left(\sum_{i=0}^4 AISN_i \cdot 2^i \right) - 16 \right]$$

where $AISN_i = 0$ or 1

There are two special cases to the formula for h_{AISN} : 1) a value of $AISN = 00000$ will specify a gain of 0 (or cutoff), and 2) a value of $AISN = 10000$ is a special case where the AISN circuitry is disabled and VOUT is connected internally to VIN with a gain of 0 dB. This allows a Full Digital Loopback state where an input digital PCM signal is completely processed through the receive section, looped back, processed through the transmit section, and output as digital PCM data.

During this test, the VIN input is ignored and the VOUT output is connected to VREF.

Speech Coding

The A/D and D/A conversion follows either the A-law or the μ -law standard as defined in ITU-T Recommendation G.711. A-law or μ -law operation is programmed using MPI Commands 24 and 25. Alternate bit inversion is performed as part of the A-law coding. The QSLAC device provides linear code as an option on both the transmit and receive sides of the device. Linear code is selected using MPI Commands 24 and 25. Two successive time slots are required for linear code operation. The linear code is a 16-bit two's-complement number which appears sign bit first on the PCM highway. Linear code occupies two time slots.

Signaling on the PCM Highway

If the SMODE bit is set in the Configuration register, each data point occupies two consecutive time slots. The first time slot contains A-law or μ -law data and the second time slot will have the following information:

- Bit 7: Debounced CD1 bit (usually hookswitch)
- Bit 6: CD2 bit or CD1B bit
- Bits 5–3: Reserved
- Bit 2: CFAIL
- Bits 1–0: Reserved

Bit 7 of the signaling byte will appear immediately after bit 0 of the data byte. A-law or μ -law Companded state must be specified in order to put signaling information on the PCM highway. The signaling time slot remains active, even when the channel is deactivated.

Robbed-Bit Signaling Compatibility

The QSLAC device supports robbed bit signaling compatibility. Robbed bit signaling allows periodic use of the least significant bit (LSB) of the receive path PCM data to be used to carry signaling information. In this scheme, separate circuitry within the line card or system intercepts this bit out of the PCM data stream and uses this bit to control signaling functions within the system. The QSLAC device does not perform any processing of any of the robbed bits during this operation; it simply allows for the robbed bit presence by performing the LSB substitution.

If the RBE bit is set, then the robbed-bit signaling compatibility mode is enabled. Robbed-bit signaling is

only available in the μ -law companding mode of the device. Also, only the receive (digital-to-analog) path is involved. There is no change of operation to the transmit path and PCM data coming out of the QSLAC device will always contain complete PCM byte data for each time slot, regardless of robbed-bit signaling selection.

In the absence of actual PCM data for the affected time slots, there is an uncertainty of the legitimate value of this bit to accurately reconstruct the analog signal. This bit can always be assumed to be a 1 or 0; hence, the reconstructed signal is correct half the time. However, the other half of the time, there is an unacceptable reconstruction error of a significance equal to the value weighting of the LSB. To reduce this error and provide compatibility with the robbed bit signaling scheme, when in the robbed-bit signaling mode, the QSLAC device ignores the LSB of each received PCM byte and replace its value in the expander with a value of half the LSB's weight. This then guarantees the reconstruction is in error by only half this LSB weight. In the expander, the eight bits of the companded PCM byte are expanded into linear PCM data of several more bits within the internal signal processing path of the device. Therefore, accuracy is not limited to the weight of the LSB, and a weight of half this value is realizable.

When this robbed-bit mode is selected, not every frame contains bits for signaling, and therefore not every byte requires its LSB substituted with the half-LSB weight. This substitution only occurs for valid PCM time slots within frames for which this robbed bit has been designated. To determine which time slots are affected, the device monitors the frame sync (FS) pulse. The current frame is a robbed-bit frame and this half-LSB value is used only when this criteria is met:

- The RBE bit is set, *and*
- The device is in the μ -law companding mode, *and*
- The current frame sync pulse (FS) is two PCLK cycles long, *and*
- The previous frame sync pulse (FS) was *not* two PCLK cycles long.

The frame sync pulse is sampled on the falling edge of PCLK. As shown in Figure 13, if the above criteria is met, and if FS is high for two consecutive falling edges of PCLK then low for the third falling edge, it is considered a robbed-bit frame. Otherwise, it is a normal frame.

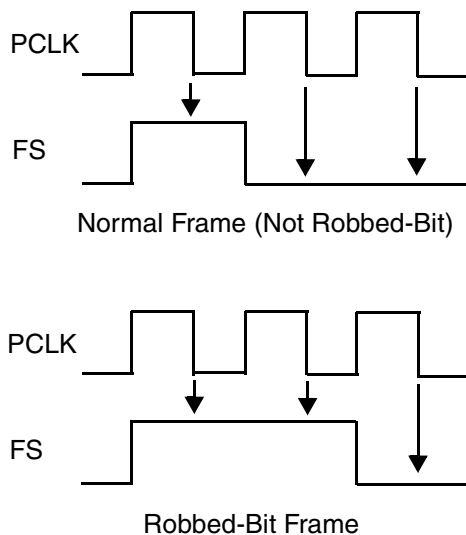

Figure 13. Robbed-Bit Frame

Default Filter Coefficients

The QSLAC device contains an internal set of default coefficients for the programmable filters. These coefficients were determined to allow reasonable system performance for initial power-up non-programmed situations, such as may exist before a system processor has opportunity to program any coefficients.

The default filter coefficients are calculated assuming an Am7920 SLIC with 50 Ω protection resistors, a 178 kΩ transversal impedance (ZT), and a 90.5 kΩ receive impedance (ZRX). This SLIC has a transmit gain of 0.5 (GTX) and a current gain of 500 (K1). The transmit relative level is set to +0.28 dB_r, and the receive relative level is set to -4.39 dB_r. The equalization filters (X and R) are not optimized. The balance filter was designed to give acceptable balance into a variety of impedances. The nominal input impedance was set to 815 Ω. If the SLIC circuit differs significantly from this design, the default filters cannot be used and must be replaced by programmed coefficients.

To obtain this above-system response, the default filter coefficients are set to produce these values:

GX gain = +6 dB, GR gain = -8.984 dB

AX gain = 0 dB, AR gain = 0 dB

R filter: $H(z) = 1$, X filter: $H(z) = 1$

Z filter: $H(z) = 0$, B filter $H(z) = 0$

AISN = cutoff

Notice that these default coefficient values are retained in a read-only memory area within the QSLAC device, and those values cannot be read back using any data commands. When the device is selected to use default coefficients, it obtains those values directly from the read-only memory area, where the coefficient read operations access the programmable random access data memory only. If an attempt is made to read back any filter values without those values first being written with known programmed data, the values read back are totally random and do not represent the default or any other values.

COMMAND DESCRIPTION AND FORMATS

Microprocessor Interface Description

A microprocessor can program and control the QSLAC device using the MPI. Data programmed previously can be read out for verification.

Commands assign values to the following channel parameters:

- Transmit time slot
- Receive time slot
- Transmit clock slot
- Receive clock slot
- Transmit gain
- Receive loss
- B-filter coefficients
- X-filter coefficients
- R-filter coefficients
- Z-filter coefficients
- AISN coefficient
- Read/Write SLIC Input/Output
- SLIC Input/Output Direction
- Select A-law, μ-law, or linear code
- Select Transmit PCM Port A or B or both
- Select Receive PCM Port A or B
- Programmed/Default B filter
- Programmed/Default Z filter
- Programmed/Default X filter
- Programmed/Default R filter
- Programmed/Default GX filter
- Programmed/Default GR filter
- Enable/disable AX amplifier
- Enable/disable AR amplifier
- Select test states
- Select Active or Inactive (standby) state

Commands are provided to read values from the following channel monitors:

- SLIC status
- Transmit PCM data

Commands are provided to assign values to the following global chip parameters:

- Transmit PCM Clock Edge
- Interrupt Output Drive state
- Chopper Clock Frequency
- Select Signaling on the PCM Highway
- Select Master Clock Frequency
- Channel Enable register
- Debounce Time for CD1
- Enable E1 Output
- E1 Polarity

Commands are provided to read values from the following global chip status monitors:

- Real Time Data register
- Power Interruption Bit
- Clock Failure Bit
- Interrupt Mask register
- Revision Code Number

The following description of the MPI (Microprocessor Interface) is valid for channel 1–4. If desired, multiple channels may be programmed simultaneously with identical information by setting multiple Channel Enable bits. Channel enables are contained in the Channel Enable register and written or read using MPI Commands 14 and 15. If multiple Channel Enable bits are set for a read operation, only data from the first enabled channel will be read.

The MPI physically consists of a serial data input/output (DIO), a data clock (DCLK), and a chip select (\overline{CS}). Individual Channel Enable bits EC1, EC2, EC3, and EC4 are stored internally in the Channel Enable register of the QSLAC device. The serial input consists of 8-bit commands which may be followed with additional bytes of input data, or may be followed by the QSLAC device sending out bytes of data. All data input and output is MSB (D7) first and LSB (D0) last. All data bytes are read or written one at a time, with \overline{CS}

going High for at least a minimum off period before the next byte is read or written. Only a single channel should be enabled during read commands.

All commands that require additional input data to the device must have the input data as the next N words written into the device (for example, framed by the next N transitions of \overline{CS}). Program all unused bits as 0 to ensure compatibility with future parts. All commands that are followed by output data will cause the device to output data for the next N transitions of \overline{CS} going Low. The QSLAC device will not accept any commands until all the data has been shifted out. The output values of unused bits are not specified.

An MPI cycle is defined by transitions of \overline{CS} and DCLK. If the \overline{CS} lines are held in the High state between accesses, the DCLK may run continuously with no change to the internal control data. Using this method, the same DCLK may be run to a number of QSLAC devices and the individual \overline{CS} lines will select the appropriate device to access. Between command sequences, DCLK can stay in the High state indefinitely with no loss of internal control information regardless of any transitions on the \overline{CS} lines. Between bytes of a multibyte read or write command sequence, DCLK can also stay in the High state indefinitely. DCLK can stay in the Low state indefinitely with no loss of internal control information, provided the \overline{CS} lines remain at a High level.

If a low period of \overline{CS} contains less than 8 positive DCLK transitions, it will be ignored. If it contains 8–15 positive transitions, only the last 8 transitions matter. If it contains 16 or more positive transitions, it will cause a hardware reset in the part. If the chip is in the middle of a read sequence when \overline{CS} goes Low, data will be present at the DIO pin even if DCLK has no activity.

SUMMARY OF MPI COMMANDS*

Number	Hex	Description
1	00	Deactivate (Standby Mode)
2	02	Software Reset
3	04	Hardware Reset
4	06	No Operation
5	0E	Activate (Operational Mode)
6,7	40/41	Write/Read Transmit Time Slot and PCM Highway Selection
8,9	42/43	Write/Read Receive Time Slot and PCM Highway Selection
10,11	44/45	Write/Read REC & TX Clock Slot and TX Edge
12,13	46/47	Write/Read Configuration Register
14,15	4A/4B	Write/Read Channel Enable & Operating Mode Register
16	4D	Read Real Time Data Register
17	4F	Read Real Time Data Register and Clear Interrupt
18,19	50/51	Write/Read AISN and Analog Gains
20,21	52/53	Write/Read SLIC Input/Output Register
22,23	54,55	Write/Read SLIC Input/Output Direction and Status Bits
24,25	60/61	Write/Read Operating Functions
26,27	6C/6D	Write/Read Interrupt Mask Register
28,29	70/71	Write/Read Operating Conditions
30	73	Read Revision Code Number (RCN)
31,32	80/81	Write/Read GX Filter Coefficients
33,34	82/83	Write/Read GR Filter Coefficients
35,36	84/85	Write/Read Z Filter Coefficients (FIR and IIR)
37, 38	86/87	Write/Read B1 Filter Coefficients (FIR)
39, 40	88/89	Write/Read X Filter Coefficients
41, 42	8A/8B	Write/Read R Filter Coefficients
43, 44	96/97	Write/Read B2 Filter Coefficients (IIR)
45, 46	C8/C9	Write/Read Debounce Time Register
47	CD	Read Transmit PCM Data
48, 49	98/99	Write/Read Z Filter Coefficients (FIR only)
50, 51	9A/9B	Write/Read Z Filter Coefficients (IIR only)
52,53	E8/E9h	Write/Read Ground Key Filter Sampling Interval

Note:

*All codes not listed are reserved by Legerity and should not be used.

MPI COMMAND STRUCTURE

This section details each MPI command. Each command is shown along with the format of any additional data bytes that follow. For details of the filter coefficients of the form $C_{xy}m_{xy}$, refer to the *General Description of CSD Coefficients* section on page 56.

Unused bits are indicated by “RSVD”; 0’s should be written to them, but 0’s are not guaranteed when they are read.

*Default field values are marked by an asterisk. A hardware reset forces the default values.

1. Deactivate (Standby State)

MPI Command

(00h)

	D ₇	D ₆	D ₅	D ₄	D ₃	D ₂	D ₁	D ₀
Command	0	0	0	0	0	0	0	0

In the Deactivated mode:

All programmed information is retained.

The Microprocessor Interface (MPI) remains active.

The PCM inputs are disabled and the PCM outputs are high impedance unless signaling on the PCM highway is programmed (SMODE = 1).

The analog output (VO_{UT}) is disabled and biased at 2.1 V.

The channel status (\overline{CS}) bit in the SLIC I/O Direction and Channel Status Register is set to 0.

2. Software Reset

MPI Command

(02h)

	D ₇	D ₆	D ₅	D ₄	D ₃	D ₂	D ₁	D ₀
Command	0	0	0	0	0	0	1	0

The action of this command is identical to that of the \overline{RST} pin except that it only operates on the channels selected by the Channel Enable Register and it does not change clock slots, time slots, PCM highways, or global chip parameters. See the note under the hardware reset command that follows.

3. Hardware Reset

MPI Command

(04h)

	D ₇	D ₆	D ₅	D ₄	D ₃	D ₂	D ₁	D ₀
Command	0	0	0	0	0	1	0	0

Hardware reset is equivalent to pulling the \overline{RST} on the device Low. This command does not depend on the state of the Channel Enable Register.

Note: The action of a hardware reset is described in Reset States on page 31 of the section Operating the QSLAC Device.

4. No Operation

MPI Command

(06h)

	D ₇	D ₆	D ₅	D ₄	D ₃	D ₂	D ₁	D ₀
Command	0	0	0	0	0	1	1	0

5. Activate Channel (Operational Mode)

MPI Command

(0Eh)

	D ₇	D ₆	D ₅	D ₄	D ₃	D ₂	D ₁	D ₀
Command	0	0	0	0	1	1	1	0

This command places the device in the Active mode and sets CSTAT = 1. No valid PCM data is transmitted until after the second FS pulse is received following the execution of the Activate command.

6, 7. Write/Read Transmit Time Slot and PCM Highway Selection

MPI Command

(40/41h)

R/W = 0: Write

R/W = 1: Read

	D ₇	D ₆	D ₅	D ₄	D ₃	D ₂	D ₁	D ₀
Command	0	1	0	0	0	0	0	R/W
I/O Data	TPCM	TTS6	TTS5	TTS4	TTS3	TTS2	TTS1	TTS0

Transmit PCM Highway

TPCM = 0* Transmit on Highway A (see TAB in Commands 10, 11)
 TPCM = 1 Transmit on Highway B (see TAB in Commands 10, 11)

Transmit Time Slot

TTS = 0–127 Time Slot Number (TTS0 is LSB, TTS6 is MSB)

PCM Highway B is not available on the Am79Q021/031 QSLAC devices.

* Power Up and Hardware Reset (\overline{RST}) Value = 00h, 01h, 02h, 03h for Channels 1, 2, 3, and 4, respectively.

8, 9. Write/Read Receive Time Slot and PCM Highway Selection

MPI Command

(42/43h)

R/W = 0: Write

R/W = 1: Read

	D ₇	D ₆	D ₅	D ₄	D ₃	D ₂	D ₁	D ₀
Command	0	1	0	0	0	0	1	R/W
I/O Data	RPCM	RTS6	RTS5	RTS4	RTS3	RTS2	RTS1	RTS0

Receive PCM Highway

RPCM = 0* Receive on Highway A
 RPCM = 1 Receive on Highway B

Receive Time Slot

RTS = 0–127 Time Slot Number (RTS0 is LSB, RTS6 is MSB)

PCM Highway B is not available on the Am79Q021 and the Am79Q031 QSLAC devices.

* Power Up and Hardware Reset (\overline{RST}) Value = 00h, 01h, 02h, 03h for Channels 1, 2, 3, and 4, respectively.

10, 11. Write/Read Transmit Clock Slot, Receive Clock Slot, and Transmit Clock Edge MPI Command

(44/45h)

R/W = 0: Write

R/W = 1: Read

	D ₇	D ₆	D ₅	D ₄	D ₃	D ₂	D ₁	D ₀
Command	0	1	0	0	0	1	0	R/W
I/O Data	TAB	XE	RCS2	RCS1	RCS0	TCS2	TCS1	TCS0

Transmit on A and B

TAB = 0* Transmit data on highway selected by TPCM (See Commands 6,7 on page 40).

TAB = 1 Transmit data on both highways A and B

Transmit Edge

XE = 0* Transmit changes on negative edge of PCLK

XE = 1 Transmit changes on positive edge of PCLK

Receive Clock Slot

RCS = 0*–7 Receive Clock Slot number

Transmit Clock Slot

TCS = 0*–7 Transmit Clock Slot number

The XE bit and the clock slots apply to all four channels; however, they cannot be written or read unless at least one channel is selected in the Channel Enable Register.

* Power Up and Hardware Reset (\overline{RST}) Value = 00h.

12, 13. Write/Read Configuration Register MPI Command

MPI Command

(46/47h)

R/W = 0: Write

R/W = 1: Read

	D ₇	D ₆	D ₅	D ₄	D ₃	D ₂	D ₁	D ₀
Command	0	1	0	0	0	1	1	R/W
I/O Data	INTM	CHP	SMODE	CMODE	CSEL3	CSEL2	CSEL1	CSEL0

Interrupt Mode

INTM = 0 TTL-compatible output

INTM = 1* Open drain output

Chopper Clock Control

CHP = 0* Chopper Clock is 256 kHz (2048/8 kHz)

CHP = 1 Chopper Clock is 292.57 kHz (2048/7 kHz)

PCM Signaling Mode

SMODE = 0* No signaling on PCM highway

SMODE = 1 Signaling on PCM highway

Clock Source Mode

CMODE = 0 MCLK used as master clock; no E1 multiplexing allowed

CMODE = 1* PCLK used as master clock; E1 multiplexing allowed if enabled in commands 49, 50.

The master clock frequency can be selected by CSEL. The master clock frequency selection affects all channels.

Master Clock Frequency

CSEL = 0000	1.536 MHz
CSEL = 0001	1.544 MHz
CSEL = 0010	2.048 MHz
CSEL = 0011	Reserved
CSEL = 01xx	Two times frequency specified above (2 x 1.536 MHz, 2 x 1.544 MHz, or 2 x 2.048 MHz)
CSEL = 10xx	Four times frequency specified above (4 x 1.536 MHz, 4 x 1.544 MHz, or 4 x 2.048 MHz)
CSEL = 11xx	Reserved
CSEL = 1010*	8.192 MHz is the default

These commands do not depend on the state of the Channel Enable Register.

* Power Up and Hardware Reset (\overline{RST}) Value = 9Ah.

14, 15. Write/Read Channel Enable and Operating Mode Register

MPI Command

(4A/4B)

R/W = 0: Write

R/W = 1: Read

	D ₇	D ₆	D ₅	D ₄	D ₃	D ₂	D ₁	D ₀
Command	0	1	0	0	1	0	1	R/W
I/O Data	RSVD	RBE	VMODE	LPM	EC4	EC3	EC2	EC1

RSVD Reserved for future use. Always write as 0, but 0 is not guaranteed when read.

Robbed-bit Mode

RBE = 0*	Robbed-bit Signaling mode is disabled.
RBE = 1	Robbed-bit Signaling mode is enabled on PCM receiver if μ -law is selected.

VOUT Mode

VMODE = 0*	VOUT = VREF through a resistor when channel is deactivated
VMODE = 1	VOUT high impedance when channel is deactivated.

Low Power Mode

LPM = 0*	Low Power mode off
LPM = 1	Low Power mode on while all channels are inactive

Channel Enable 4

EC4 = 0	Disabled, Channel 4 cannot receive commands
EC4 = 1*	Enabled, Channel 4 can receive commands

Channel Enable 3

EC3 = 0	Disabled, Channel 3 cannot receive commands
EC3 = 1*	Enabled, Channel 3 can receive commands

Channel Enable 2

EC2 = 0	Disabled, Channel 2 cannot receive commands
EC2 = 1*	Enabled, Channel 2 can receive commands

Channel Enable 1

EC1 = 0	Disabled, Channel 1 cannot receive commands
EC1 = 1*	Enabled, Channel 1 can receive commands

* Power Up and Hardware Reset (\overline{RST}) Value = 0Fh.

16, 17. Read Real-Time Data Register

MPI Command

(4D/4Fh)

C = 0: Do not clear interrupt

C = 1: Clear interrupt

This register writes/reads real-time data with or without clearing the interrupt.

	D ₇	D ₆	D ₅	D ₄	D ₃	D ₂	D ₁	D ₀
Command	0	1	0	0	1	1	C	1
Output Data	CDB4	CDA4	CDB3	CDA3	CDB2	CDA2	CDB1	CDA1

Real Time Data

CDA1	Debounced data bit 1 on Channel 1
CDB1	Data bit 2 or multiplexed data bit 1 on Channel 1
CDA2	Debounced data bit 1 on Channel 2
CDB2	Data bit 2 or multiplexed data bit 1 on Channel 2
CDA3	Debounced data bit 1 on Channel 3
CDB3	Data bit 2 or multiplexed data bit 1 on Channel 3
CDA4	Debounced data bit 1 on Channel 4
CDB4	Data bit 2 or multiplexed data bit 1 on Channel 4

This command does not depend on the state of the Channel Enable Register.

18, 19. Write/Read AISN and Analog Gains

MPI Command

(50/51h)

R/W = 0: Write

R/W = 1: Read

	D ₇	D ₆	D ₅	D ₄	D ₃	D ₂	D ₁	D ₀
Command	0	1	0	1	0	0	0	R/W
I/O Data	RSVD	AX	AR	AISN4	AISN3	AISN2	AISN1	AISN0

RSVD Reserved for future use. Always write as 0, but 0 is not guaranteed when read.

Transmit Analog Gain

AX = 0*	0 dB gain
AX = 1	6.02 dB gain

Receive Analog Loss

AR = 0*	0 dB loss
AR = 1	6.02 dB loss

AISN coefficient

AISN = 0* – 31 See below (Default value = 0)
 The Impedance Scaling Network (AISN) gain can be varied from –0.9375 to 0.9375 in multiples of 0.0625. The gain coefficient is decoded using the following equation:

$$h_{AISN} = 0.0625[(16 \cdot AISN4 + 8 \cdot AISN3 + 4 \cdot AISN2 + 2 \cdot AISN1 + AISN0) - 16]$$
 where h_{AISN} is the gain of the AISN. A value of AISN = 10000 turns on the Full Digital Loopback mode and a value of AISN = 0000* indicates a gain of 0 (cutoff).

* Power Up and Hardware Reset (\overline{RST}) Value = 00h.

20, 21. Write/Read SLIC Input/Output Register

MPI Command

(52/53h)

R/W = 0: Write

R/W = 1: Read

	D ₇	D ₆	D ₅	D ₄	D ₃	D ₂	D ₁	D ₀
Command	0	1	0	1	0	0	1	R/W
I/O Data	RSVD	RSVD	CD1B	C5	C4	C3	CD2	CD1

RSVD Reserved for future use. Always write as 0, but 0 is not guaranteed when read.

Pins CD1, CD2, and C3 through C5 are set to 1 or 0. The data appears latched on the CD1, CD2, and C3 through C5 SLIC I/O pins, provided they were set in the Output mode (see Command 22). The data sent to any of the pins set to the Input mode is latched, but does not appear at the pins. The CD1B bit is only valid if the E1 Multiplex mode is enabled (EE1 = 1).

* Power Up and Hardware Reset ($\overline{\text{RST}}$) Value = 00h

22, 23. Write/Read SLIC Input/Output Direction, Read Status Bits

MPI Command

(54/55h)

	D ₇	D ₆	D ₅	D ₄	D ₃	D ₂	D ₁	D ₀
Command	0	1	0	1	0	1	0	R/W
Input Data	RSVD	CSTAT	CFAIL	IOD5	IOD4	IOD3	IOD2	IOD1

RSVD Reserved for future use. Always write as 0, but 0 is not guaranteed when read.

Channel Status (Read status only, write as 0)

CSTAT = 0 Channel is inactive (Standby mode).

CSTAT = 1 Channel is active.

Clock Fail (Read status only, write as 0)

CFAIL* = 0 The internal clock is synchronized to frame synch.

CFAIL = 1 The internal clock is not synchronized to frame synch.

* The CFAIL bit is independent of the Channel Enable Register.

I/O Direction (Read/Write)

IOD5 = 0* C5 is an input

IOD5 = 1 C5 is an output

IOD4 = 0* C4 is an input

IOD4 = 1 C4 is an output

IOD3 = 0* C3 is an input

IOD3 = 1 C3 is an output

IOD2 = 0* CD2 is an input

IOD2 = 1 CD2 is an output

IOD1 = 0* CD1 is an input

IOD1 = 1 CD1 is an output

Pins CD1, CD2, and C3 through C5 are set to Input or Output modes individually. Pins C3–C5 are not available on the Am79Q031 QSLAC device, and C5 is available only on the Am79Q021 QSLAC device.

* Power Up and Hardware Reset ($\overline{\text{RST}}$) Value = 00h

24, 25. Write/Read Operating Functions

MPI Command

(60/61h)

R/W = 0: Write

R/W = 1: Read

	D ₇	D ₆	D ₅	D ₄	D ₃	D ₂	D ₁	D ₀
Command	0	1	1	0	0	0	0	R/W
I/O Data	C/L	A/ μ	EGR	EGX	EX	ER	EZ	EB

Linear Code

C/L = 0* Compressed coding
 C/L = 1 Linear coding

A-law or μ -law

A/ μ = 0* A-law coding
 A/ μ = 1 μ -law coding

GR Filter

EGR = 0* Default GR filter enabled
 EGR = 1 Programmed GR filter enabled

GX Filter

EGX = 0* Default GX filter enabled
 EGX = 1 Programmed GX filter enabled

X Filter

EX = 0* Default X filter enabled
 EX = 1 Programmed X filter enabled

R Filter

ER = 0* Default R filter enabled
 ER = 1 Programmed R filter enabled

Z Filter

EZ = 0* Default Z filter enabled
 EZ = 1 Programmed Z filter enabled

B Filter

EB = 0* Default B filter enabled
 EB = 1 Programmed B filter enabled

* Power Up and Hardware Reset ($\overline{\text{RST}}$) Value = 00h.

26, 27. Write/Read Interrupt Mask Register

MPI Command

(6C/6Dh)

R/W = 0: Write

R/W = 1: Read

	D ₇	D ₆	D ₅	D ₄	D ₃	D ₂	D ₁	D ₀
Command	0	1	1	0	1	1	0	R/W
I/O Data	MCDB4	MCDA4	MCDB3	MCDA3	MCDB2	MCDA2	MCDB1	MCDA1

Mask CD Interrupt

MCDxy = 0 CDxy bit is NOT MASKED

MCDxy = 1* CDxy bit is MASKED

x Bit number (A or B)

y Channel number (1 through 4)

Masked: A change does not cause the Interrupt Pin to go Low.

This command does not depend on the state of the Channel Enable Register.

* Power Up and Hardware Reset ($\overline{\text{RST}}$) Value = FFh.

28, 29. Write/Read Operating Conditions

MPI Command

(70/71h)

R/W = 0: Write

R/W = 1: Read

	D ₇	D ₆	D ₅	D ₄	D ₃	D ₂	D ₁	D ₀
Command	0	1	1	1	0	0	0	R/W
I/O Data	CTP	CRP	HPF	RG	ATI	ILB	FDL	TON

Cutoff Transmit Path

CTP = 0* Transmit path connected

CTP = 1 Transmit path cut off

Cutoff Receive Path

CRP = 0* Receive path connected

CRP = 1 Receive path cutoff (see note)

High Pass Filter

HPF = 0* Transmit Highpass filter enabled

HPF = 1 Transmit Highpass filter disabled

Lower Receive Gain

RG = 0* 6 dB loss not inserted

RG = 1 6 dB loss inserted

Arm Transmit Interrupt

ATI = 0* Transmit Interrupt not Armed

ATI = 1 Transmit Interrupt Armed

Interface Loopback

ILB = 0* TSA loopback disabled

ILB = 1 TSA loopback enabled

Full Digital Loopback

FDL = 0* Full digital loopback disabled

FDL = 1 Full digital loopback enabled

1 kHz Receive Tone

TON = 0* 1 kHz receive tone off

TON = 1 1 kHz receive tone on

* Power Up and Hardware Reset ($\overline{\text{RST}}$) Value = 00h.

The B Filter is disabled during receive cutoff.

30. Read Revision Code Number (RCN)

MPI Command

(73h)

	D ₇	D ₆	D ₅	D ₄	D ₃	D ₂	D ₁	D ₀
Command	0	1	1	1	0	0	1	1
I/O Data	RCN7	RCN6	RCN5	RCN4	RCN3	RCN2	RCN1	RCN0

This command returns an 8-bit number (RCN) describing the revision number of the QSLAC device. This command does not depend on the state of the Channel Enable Register.

31, 32. Write/Read GX Filter Coefficients

MPI Command

(80/81h)

R/W = 0: Write

R/W = 1: Read

	D ₇	D ₆	D ₅	D ₄	D ₃	D ₂	D ₁	D ₀
Command	1	0	0	0	0	0	0	R/W
I/O Data Byte 1	C40	m40			C30	m30		
I/O Data Byte 2	C20	m20			C10	m10		

The coefficient for the GX filter is defined as:

$$H_{GX} = 1 + (C10 \cdot 2^{-m10} \{1 + C20 \cdot 2^{-m20} [1 + C30 \cdot 2^{-m30} (1 + C40 \cdot 2^{-m40})]\})$$

Power Up and Hardware Reset (\overline{RST}) Values = A9F0 (Hex) ($H_{GX} = 1.995$ (6 dB)).

Note: The default value is contained in a ROM register separate from the programmable coefficient RAM. There is a filter enable bit in Operating Functions Register to switch between the default and programmed values.

33, 34. Write/Read GR Filter Coefficients

MPI Command

(82/83h)

R/W = 0: Write

R/W = 1: Read

	D ₇	D ₆	D ₅	D ₄	D ₃	D ₂	D ₁	D ₀
Command:	1	0	0	0	0	0	1	R/W
I/O Data Byte 1	C40	m40			C30	m30		
I/O Data Byte 2	C20	m20			C10	m10		

The coefficient for the GR filter is defined as:

$$H_{GR} = C10 \cdot 2^{-m10} \{1 + C20 \cdot 2^{-m20} [1 + C30 \cdot 2^{-m30} (1 + C40 \cdot 2^{-m40})]\}$$

Power Up and Hardware Reset (\overline{RST}) Values = 23A1 (Hex) ($H_{GR} = 0.35547$ (-8.984 dB)).

See note under Commands 31 and 32.

35, 36. Write/Read Z Filter Coefficients (FIR and IIR)

MPI Command

(84/85h)

R/W = 0: Write

R/W = 1: Read

This command writes and reads both the FIR and IIR filter sections simultaneously.

	D ₇	D ₆	D ₅	D ₄	D ₃	D ₂	D ₁	D ₀
Command	1	0	0	0	0	1	0	R/W
I/O Data Byte 1	C40	m40			C30	m30		
I/O Data Byte 2	C20	m20			C10	m10		
I/O Data Byte 3	C41	m41			C31	m31		
I/O Data Byte 4	C21	m21			C11	m11		
I/O Data Byte 5	C42	m42			C32	m32		
I/O Data Byte 6	C22	m22			C12	m12		
I/O Data Byte 7	C43	m43			C33	m33		
I/O Data Byte 8	C23	m23			C13	m13		
I/O Data Byte 9	C44	m44			C34	m34		
I/O Data Byte 10	C24	m24			C14	m14		
I/O Data Byte 11	C45	m45			C35	m35		
I/O Data Byte 12	C25	m25			C15	m15		
I/O Data Byte 13	C26	m26			C16	m16		
I/O Data Byte 14	C47	m47			C37	m37		
I/O Data Byte 15	C27	m27			C17	m17		

The Z-transform equation for the Z filter is defined as:

$$H_z(z) = z_0 + z_1 \cdot z^{-1} + z_2 \cdot z^{-2} + z_3 \cdot z^{-3} + z_4 \cdot z^{-4} + \frac{z_5 \cdot z_6 \cdot z_7 \cdot z^{-1}}{1 - z_7 \cdot z^{-1}}$$

Sample rate = 32 kHz

For i = 0 to 5 and 7

$$z_i = C1i \cdot 2^{-m1i} \{1 + C2i \cdot 2^{-m2i} [1 + C3i \cdot 2^{-m3i} (1 + C4i \cdot 2^{-m4i})]\}$$

$$z_6 = C16 \cdot 2^{-m16} \{1 + C26 \cdot 2^{-m26}\}$$

Power Up and Hardware Reset (\overline{RST}) Values = 0190 0190 0190 0190 0190 0190 01 0190 (Hex)

$$(H_z(z) = 0)$$

See note under Commands 31 and 32.

Note: Z_6 is used for IIR filter scaling only. Its value is typically greater than zero but less than or equal to one. The input to the IIR filter section is first increased by a gain of $1/Z_6$, improving dynamic range and avoiding truncation limitations through processing within this filter. The IIR filter output is then multiplied by Z_6 to normalize the overall gain. Z_5 is the actual IIR filter gain value defined by the programmed coefficients, but it also includes the initial $1/Z_6$ gain. The theoretical effective IIR gain, without the Z_6 gain and normalization, is actually Z_5/Z_6 .

37, 38. Write/Read B1 Filter Coefficients

MPI Command

(86/87h)

R/W = 0: Write

R/W = 1: Read

	D ₇	D ₆	D ₅	D ₄	D ₃	D ₂	D ₁	D ₀
Command	1	0	0	0	0	1	1	R/W
I/O Input Data Byte 1	C32	m32			C22	m22		
I/O Input Data Byte 2	C12	m12			C33	m33		
I/O Input Data Byte 3	C23	m23			C13	m13		
I/O Input Data Byte 4	C34	m34			C24	m24		
I/O Input Data Byte 5	C14	m14			C35	m35		
I/O Input Data Byte 6	C25	m25			C15	m15		
I/O Input Data Byte 7	C36	m36			C26	m26		
I/O Input Data Byte 8	C16	m16			C37	m37		
I/O Input Data Byte 9	C27	m27			C17	m17		
I/O Input Data Byte 10	C38	m38			C28	m28		
I/O Input Data Byte 11	C18	m18			C39	m39		
I/O Input Data Byte 12	C29	m29			C19	m19		
I/O Input Data Byte 13	C310	m310			C210	m210		
I/O Input Data Byte 14	C110	m110			RSVD	RSVD		

The Z-transform equation for the B filter is defined as:

$$H_B(z) = B_2 \cdot z^{-2} + \dots + B_9 \cdot z^{-9} + \frac{B_{10} \cdot z^{-10}}{1 - B_{11} \cdot z^{-1}}$$

Sample rate = 16 kHz

The coefficients for the FIR B section and the gain of the IIR B section are defined as:

For $i = 2$ to 10,

$$B_i = C1i \cdot 2^{-mi} [1 + C2i \cdot 2^{-m2i} (1 + C3i \cdot 2^{-m3i})]$$

The feedback coefficient of the IIR B section is defined as:

$$B_{11} = C111 \cdot 2^{-m111} \{1 + C211 \cdot 2^{-m211} [1 + C311 \cdot 2^{-m311} (1 + C411 \cdot 2^{-m411})]\}$$

Refer to Commands 43, 44 for programming of the B_{11} coefficients.

Power Up and Hardware Reset (\overline{RST}) Values = 36 AB B8 22 93 AB 2B 6C 46 2C 63 B6 9F 60 (Hex)

$$(H_B(z) = -0.254 \cdot z^{-2} - 0.891 \cdot z^{-3} - 0.656 \cdot z^{-4} - 0.090 \cdot z^{-5} + 0.013 \cdot z^{-6} + 0.017 \cdot z^{-7} + 0.014 \cdot z^{-8} + 0.013 \cdot z^{-9} + \frac{0.016 \cdot z^{-10}}{1 - 0.97656 \cdot z^{-1}})$$

See note under Commands 31 and 32.

RSVD Reserved for future use. Always write as 0, but 0 is not guaranteed when read.

(88/89h)

R/W = 0: Write

R/W = 1: Read

	D ₇	D ₆	D ₅	D ₄	D ₃	D ₂	D ₁	D ₀
Command	1	0	0	0	1	0	0	R/W
I/O Input Data Byte 1	C40	m40			C30	m30		
I/O Input Data Byte 2	C20	m20			C10	m10		
I/O Input Data Byte 3	C41	m41			C31	m31		
I/O Input Data Byte 4	C21	m21			C11	m11		
I/O Input Data Byte 5	C42	m42			C32	m32		
I/O Input Data Byte 6	C22	m22			C12	m12		
I/O Input Data Byte 7	C43	m43			C33	m33		
I/O Input Data Byte 8	C23	m23			C13	m13		
I/O Input Data Byte 9	C44	m44			C34	m34		
I/O Input Data Byte 10	C24	m24			C14	m14		
I/O Input Data Byte 11	C45	m45			C35	m35		
I/O Input Data Byte 12	C25	m25			C15	m15		

The Z-transform equation for the X filter is defined as:

$$H_x(z) = x_0 + x_1z^{-1} + x_2z^{-2} + x_3z^{-3} + x_4z^{-4} + x_5z^{-5}$$

Sample rate = 16 kHz

For i = 0 to 5, the coefficients for the X filter are defined as:

$$X_i = C1i \cdot 2^{-m1i} \{1 + C2i \cdot 2^{-m2i} [1 + C3i \cdot 2^{-m3i} (1 + C4i \cdot 2^{-m4i})]\}$$

Power Up and Hardware Reset (\overline{RST}) Values = 0111 0190 0190 0190 0190 0190 (Hex)

$$(H_x(z) = 1)$$

See note under Commands 31 and 32.

41, 42. Write/Read R Filter Coefficients

MPI Command

(8A/8Bh)

R/W = 0: Write

R/W = 1: Read

	D ₇	D ₆	D ₅	D ₄	D ₃	D ₂	D ₁	D ₀
Command	1	0	0	0	1	0	1	R/W
I/O Input Data Byte 1	C46	m46			C36	m36		
I/O Input Data Byte 2	C26	m26			C16	m16		
I/O Input Data Byte 3	C40	m40			C30	m30		
I/O Input Data Byte 4	C20	m20			C10	m10		
I/O Input Data Byte 5	C41	m41			C31	m31		
I/O Input Data Byte 6	C21	m21			C11	m11		
I/O Input Data Byte 7	C42	m42			C32	m32		
I/O Input Data Byte 8	C22	m22			C12	m12		
I/O Input Data Byte 9	C43	m43			C33	m33		
I/O Input Data Byte 10	C23	m23			C13	m13		
I/O Input Data Byte 11	C44	m44			C34	m34		
I/O Input Data Byte 12	C24	m24			C14	m14		
I/O Input Data Byte 13	C45	m45			C35	m35		
I/O Input Data Byte 14	C25	m25			C15	m15		

$$HR = H_{IIR} \cdot H_{FIR}$$

The Z-transform equation for the IIR filter is defined as:

$$H_{IIR} = \frac{1 - z^{-1}}{1 - (R_6 \cdot z^{-1})}$$

Sample rate = 8 kHz

The coefficient for the IIR filter is defined as:

$$R_6 = C16 \cdot 2^{-m16} \{1 + C26 \cdot 2^{-m26} [1 + C36 \cdot 2^{-m36} (1 + C46 \cdot 2^{-m46})]\}$$

The Z-transform equation for the FIR filter is defined as:

$$H_{FIR}(z) = R_0 + R_1 z^{-1} + R_2 z^{-2} + R_3 z^{-3} + R_4 z^{-4} + R_5 z^{-5}$$

Sample rate = 16 kHz

For i = 0 to 5, the coefficients for the R2 filter are defined as:

$$R_i = C1i \cdot 2^{-m1i} \{1 + C2i \cdot 2^{-m2i} [1 + C3i \cdot 2^{-m3i} (1 + C4i \cdot 2^{-m4i})]\}$$

Power Up and Hardware Reset (\overline{RST}) Values = 2E01 0111 0190 0190 0190 0190 (Hex)

$$(H_{FIR}(z) = 1, R_6 = 0.9902)$$

See note under Commands 31 and 32.

43, 44. Write/Read B2 Filter Coefficients (IIR)

MPI Command

(96/97h)

R/W = 0: Write

R/W = 1: Read

	D ₇	D ₆	D ₅	D ₄	D ₃	D ₂	D ₁	D ₀
Command	1	0	0	1	0	1	1	R/W
I/O Data Byte 1	C411	m411			C311	m311		
I/O Data Byte 2	C211	m211			C111	m111		

This function is described in *Write/Read B1 Filter Coefficients (FIR)* on page 49.

Power Up and Hardware Reset ($\overline{\text{RST}}$) Values = AC01 (Hex) (B₁₁ = 0.97656)

See note under Commands 31 and 32.

45, 46. Write/Read Debounce Time Register**

MPI Command

(C8/C9h)

R/W = 0: Write

R/W = 1: Read

	D ₇	D ₆	D ₅	D ₄	D ₃	D ₂	D ₁	D ₀
Command	1	1	0	0	1	0	0	R/W
I/O Data	EE1	E1P	DSH3	DSH2	DSH1	DSH0	RSVD	ECH

Enable E1

EE1 = 0* E1 multiplexing turned off
 EE1 = 1 E1 multiplexing turned on

E1 Polarity

E1P = 0* E1 is a high-going pulse
 E1P = 1 E1 is a low-going pulse
 There is no E1 output unless CMODE = 1.

Debounce for Switchhook

DSH = 0–15 Debounce period in ms
 DSH contains the debouncing time (in ms) of the CD1 data (usually switchhook) entering the Real Time Data register described earlier. The input data must remain stable for the debouncing time in order to change the appropriate real time bit.

RSVD Reserved for future use. Always write as 0, but 0 is not guaranteed when read.

Enable Chopper

ECH = 0* Chopper output (CHCLK) turned off
 ECH = 1 Chopper output (CHCLK) turned on

* Power Up and Hardware Reset ($\overline{\text{RST}}$) Value = 20h.

** This command applies to all channels and does not depend on the state of the Channel Enable Register.

47. Read Transmit PCM Data

MPI Command

(CDh)

	D ₇	D ₆	D ₅	D ₄	D ₃	D ₂	D ₁	D ₀
Command	1	1	0	0	1	1	0	1
Output Data Byte 1	XDAT7	XDAT6	XDAT5	XDAT4	XDAT3	XDAT2	XDAT1	XDAT0
Output Data Byte 2	RSVD	RSVD	RSVD	RSVD	RSVD	RSVD	RSVD	RSVD

RSVD Reserved for future use. Always write as 0, but 0 is not guaranteed when read.

Upper Transmit Data

XDAT contains A-law or μ -law transmit data in Companded mode.

XDAT contains upper data byte in Linear mode with sign in XDAT7.

48, 49. Write/Read FIR Z Filter Coefficients (FIR only)

MPI Command

(98/99h)

R/W = 0: Write

R/W = 1: Read

This command writes and reads only the FIR filter section without affecting the IIR.

	D ₇	D ₆	D ₅	D ₄	D ₃	D ₂	D ₁	D ₀
Command	1	0	0	1	1	0	0	R/W
I/O Data Byte 1	C40	m40			C30	m30		
I/O Data Byte 2	C20	m20			C10	m10		
I/O Data Byte 3	C41	m41			C31	m31		
I/O Data Byte 4	C21	m21			C11	m11		
I/O Data Byte 5	C42	m42			C32	m32		
I/O Data Byte 6	C22	m22			C12	m12		
I/O Data Byte 7	C43	m43			C33	m33		
I/O Data Byte 8	C23	m23			C13	m13		
I/O Data Byte 9	C44	m44			C34	m34		
I/O Data Byte 10	C24	m24			C14	m14		

The Z-transform equation for the Z filter is defined as:

$$H_z(z) = z_0 + z_1 \cdot z^{-1} + z_2 \cdot z^{-2} + z_3 \cdot z^{-3} + z_4 \cdot z^{-4} + \frac{z_5 \cdot z_6 \cdot z_7 \cdot z^{-1}}{1 - z_7 \cdot z^{-1}}$$

Sample rate = 32 kHz

For i = 0 to 5 and 7

$$z_i = C1i \cdot 2^{-m1i} \{1 + C2i \cdot 2^{-m2i} [1 + C3i \cdot 2^{-m3i} (1 + C4i \cdot 2^{-m4i})]\}$$

$$z_6 = C16 \cdot 2^{-m16} \{1 + C26 \cdot 2^{-m26}\}$$

Power Up and Hardware Reset ($\overline{\text{RST}}$) Values = 0190 0190 0190 0190 0190 0190 01 0190 (Hex)

$$(H_z(z) = 0)$$

See note under Commands 31 and 32.

Note: Z_6 is used for IIR filter scaling only. Its value is typically greater than zero but less than or equal to one. The input to the IIR filter section is first increased by a gain of $1/Z_6$, improving dynamic range and avoiding truncation limitations through processing within this filter. The IIR filter output is then multiplied by Z_6 to normalize the overall gain. Z_5 is the actual IIR filter gain value defined by the programmed coefficients, but it also includes the initial $1/Z_6$ gain. The theoretical effective IIR gain, without the Z_6 gain and normalization, is actually Z_5/Z_6 .

50, 51. Write/Read IIR Z Filter Coefficients (IIR only)

MPI Command

(9A/9Bh)

R/W = 0: Write

R/W = 1: Read

This command writes/reads the IIR filter section only, without affecting the FIR.

	D ₇	D ₆	D ₅	D ₄	D ₃	D ₂	D ₁	D ₀
Command	1	0	0	1	1	0	1	R/W
I/O Data Byte 11	C45	m45			C35	m35		
I/O Data Byte 12	C25	m25			C15	m15		
I/O Data Byte 13	C26	m26			C16	m16		
I/O Data Byte 14	C47	m47			C37	m37		
I/O Data Byte 15	C27	m27			C17	m17		

The Z-transform equation for the Z filter is defined as:

$$H_z(z) = z_0 + z_1 \cdot z^{-1} + z_2 \cdot z^{-2} + z_3 \cdot z^{-3} + z_4 \cdot z^{-4} + \frac{z_5 \cdot z_6 \cdot z_7 \cdot z^{-1}}{1 - z_7 \cdot z^{-1}}$$

Sample rate = 32 kHz

For i = 0 to 5 and 7

$$z_i = C1i \cdot 2^{-m1i} \{1 + C2i \cdot 2^{-m2i} [1 + C3i \cdot 2^{-m3i} (1 + C4i \cdot 2^{-m4i})]\}$$

$$z_6 = C16 \cdot 2^{-m16} \{1 + C26 \cdot 2^{-m26}\}$$

Power Up and Hardware Reset ($\overline{\text{RST}}$) Values = 0190 0190 0190 0190 0190 0190 01 0190 (Hex)

$$(H_z(z) = 0)$$

See note under Commands 31 and 32.

Note: Z_6 is used for IIR filter scaling only. Its value is typically greater than zero but less than or equal to one. The input to the IIR filter section is first increased by a gain of $1/Z_6$, improving dynamic range and avoiding truncation limitations through processing within this filter. The IIR filter output is then multiplied by Z_6 to normalize the overall gain. Z_5 is the actual IIR filter gain value defined by the programmed coefficients, but it also includes the initial $1/Z_6$ gain. The theoretical effective IIR gain, without the Z_6 gain and normalization, is actually Z_5/Z_6 .

52, 53. Write/Read Ground Key Filter

MPI Command

(E8/E9h)

R/W = 0: Write

R/W = 1: Read

	D ₇	D ₆	D ₅	D ₄	D ₃	D ₂	D ₁	D ₀
Command	1	1	1	0	1	0	0	R/W
I/O Data	RSVD	RSVD	RSVD	RSVD	GK3	GK2	GK1	GK0

Filter Ground Key

GK = 0–15 Filter sampling period in 1 ms

GK contains the filter sampling time (in ms) of the CD1B data (usually Ground Key) or CD2 entering the Real Time Data register described earlier. A value of 0 disables the Ground Key filter for that particular channel.

Power Up and Hardware Reset ($\overline{\text{RST}}$) Value = 00h.

RSVD Reserved for future use. Always write as 0, but 0 is not guaranteed when read.

PROGRAMMABLE FILTERS

General Description of CSD Coefficients

The filter functions are performed by a series of multiplications and accumulations. A multiplication occurs by repeatedly shifting the multiplicand and summing the result with the previous value at that summation node. The method used in the QSLAC device is known as Canonic Signed Digit (CSD) multiplication and splits each coefficient into a series of CSD coefficients.

Each programmable FIR filter section has the following general transfer function:

$$HF(z) = h_0 + h_1 z^{-1} + h_2 z^{-2} + \dots + h_n z^{-n} \quad \text{Equation 1}$$

where the number of taps in the filter = $n + 1$.

The transfer function for the IIR part of Z and B filters:

$$HI(z) = \frac{1}{1 - h_{(n+1)} z^{-1}} \quad \text{Equation 2}$$

The transfer function of the IIR part of the R filter is:

$$HI(z) = \frac{1 - z^{-1}}{1 - h_{(n+1)} z^{-1}} \quad \text{Equation 3}$$

The values of the user-defined coefficients (h_i) are assigned via the MPI. Each of the coefficients (h_i) is defined in the following general equation:

$$h_i = B_1 2^{-M_1} + B_2 2^{-M_2} + \dots + B_N 2^{-M_N} \quad \text{Equation 4}$$

where:

M_i = the number of shifts = $M_i \leq M_i + 1$

B_i = sign = ± 1

N = number of CSD coefficients.

h_i in Equation 4 represents a decimal number, broken down into a sum of successive values of:

1) ± 1.0 multiplied by 2^{-0} , or 2^{-1} , or $2^{-2} \dots 2^{-7} \dots$

2) ± 1.0 multiplied by 1, or 1/2, or 1/4 ... 1/128 ...

The limit on the negative powers of 2 is determined by the length of the registers in the ALU.

The coefficient h_i in Equation 4 is a value made up of N binary 1s in a binary register where the left part represents whole numbers, the right part decimal fractions, and a decimal point separates them. The first binary 1 is shifted M_1 bits to the right of the decimal point; the second binary 1 is shifted M_2 bits to the right of the decimal point; the third binary 1 is shifted M_3 bits to the right of the decimal point, and so on.

When M_1 is 0, the value is a binary 1 in front of the decimal point, that is, no shift. If M_2 is also 0, the result is another binary 1 in front of the decimal point, giving a total value of binary 10 in front of the decimal point (i.e., a decimal value of 2.0). The value of N , therefore, determines the range of values the coefficient h_i can take (e.g., if $N = 3$ the maximum and minimum values are ± 3 , and if $N = 4$ the values are between ± 4).

Detailed Description of QSLAC Device Coefficients

The CSD coding scheme in the QSLAC device uses a value called m_i , where m_1 represents the distance shifted right of the decimal point for the first binary 1. m_2 represents the distance shifted to the right of the previous binary 1, and m_3 represents the number of shifts to the right of the second binary 1. Note that the range of values determined by N is unchanged. Equation 4 is now modified (in the case of $N = 4$) to:

$$h_i = B_1 2^{-m_1} + B_2 2^{-m_2} + B_3 2^{-m_3} + B_4 2^{-m_4} \quad \text{Equation 5}$$

$$h_i = C_1 \cdot 2^{-m_1} + C_1 \cdot C_2 \cdot 2^{-(m_1 + m_2)} + C_1 \cdot C_2 \cdot C_3 \cdot 2^{-(m_1 + m_2 + m_3)} + C_1 \cdot C_2 \cdot C_3 \cdot C_4 \cdot 2^{-(m_1 + m_2 + m_3 + m_4)} \quad \text{Equation 6}$$

$$h_i = C_1 \cdot 2^{-m_1} \{1 + C_2 \cdot 2^{-m_2} [1 + C_3 \cdot 2^{-m_3} (1 + C_4 \cdot 2^{-m_4})]\} \quad \text{Equation 7}$$

where:

$$\begin{aligned} M_1 &= m_1 & B_1 &= C_1 \\ M_2 &= m_1 + m_2 & B_2 &= C_1 \cdot C_2 \\ M_3 &= m_1 + m_2 + m_3 & B_3 &= C_1 \cdot C_2 \cdot C_3 \\ M_4 &= m_1 + m_2 + m_3 + m_4 & B_4 &= C_1 \cdot C_2 \cdot C_3 \cdot C_4 \end{aligned}$$

In the QSLAC device, a coefficient, h_i , consists of N CSD coefficients, each being made up of 4 bits and formatted as $C_{xy} m_{xy}$, where C_{xy} is 1 bit (MSB) and m_{xy} is 3 bits. Each CSD coefficient is broken down as follows:

C_{xy} is the sign bit (0 = positive, 1 = negative).

m_{xy} is the 3-bit shift code. It is encoded as a binary number as follows:

000:	0 shifts
001:	1 shifts
010:	2 shifts
011:	3 shifts
100:	4 shifts
101:	5 shifts
110:	6 shifts
111:	7 shifts

y is the coefficient number (the i in h_i).

x is the position of this CSD coefficient within the h_i coefficient. The most significant binary 1 is represented by $x = 1$. The next most significant binary 1 is represented by $x = 2$, and so on.

Thus, $C_{13} m_{13}$ represents the sign and the relative shift position for the first (most significant) binary 1 in the 4th (h_3) coefficient.

The number of CSD coefficients, N, is limited to 4 in the GR, GX, R, X, and Z filters; 4 in the IIR part of the B filter; 3 in the FIR part of the B filter; and 2 in the post-gain factor of the Z-IIR filter. The GX filter coefficient equation is slightly different from the other filters.

$$h_{iGX} = 1 + h_i \quad \text{Equation 8}$$

Please refer to the section detailing the commands for complete details on programming the coefficients.

User Test States and Operating Conditions

The QSLAC device supports testing by providing test states and special operating conditions as shown in Figure 9 (see Operating Conditions register).

Cutoff Transmit Path (CTP): When $CTP = 1$, \overline{DX} and \overline{TSC} are high impedance and the transmit time slot does not exist. This state takes precedence over the TSA Loopback (TLB) and Full Digital Loopback (FDL) states.

Cutoff Receive Path (CRP): When $CRP = 1$, the receive signal is forced to 0 just ahead of the low pass filter (LPF) block. This state also blocks Full Digital Loopback (FDL), the 1 kHz receive tone, and the B-filter path.

High Pass Filter Disable (HPF): When $HPF = 1$, all of the high pass and notch filters in the transmit path are disabled.

Lower Receive Gain (LRG): When $LRG = 1$, an extra 6.02 dB of loss is inserted into the receive path.

Arm Transmit Interrupt (ATI) and Read Transmit PCM Data: The read transmit PCM data command, Command 47, can be used to read transmit PCM data through the microprocessor interface. If the ATI bit is set, an interrupt will be generated whenever new transmit data appears in the channel and will be cleared when the data is read. When combined with Tone Generation and Loopback states, this allows the microprocessor to test channel integrity.

TSA Loopback (TLB): When $TLB = 1$, data from the TSA receive path is looped back to the TSA transmit path. Any other data in the transmit path is overwritten.

Full Digital Loopback (FDL): When $FDL = 1$, the VOUT output is turned off and the analog output voltage is routed to the input of the receive path, replacing the voltage from VIN. The AISN path is temporarily turned off. This test state can also be entered by writing the code 10000 into the AISN register.

1 kHz Receive Tone (TON): When $TON = 1$, a 1 kHz digital milliwatt is injected into the receive path, replacing any receive signal from the TSA.

A-Law and μ -Law Companding

Table 2 and Table 3 show the companding definitions used for A-law and μ -law PCM encoding.

Table 2. A-Law: Positive Input Values

1 Segment Number	2 # Intervals x Interval Size	3 Value at Segment End Points	4 Decision Value Number n	5 Decision Value x_n (See Note 1)	6 Character Signal pre Inversion of Even Bits	7 Quantized Value (at Decoder Output) y_n	8 Decoder Output Value No.
					Bit No. 1 2 3 4 5 6 7 8		
7	16 x 128	4096	(128)	(4096)	-----	4032	128
			127	3968	1 1 1 1 1 1 1 1		
			113	2176	See Note 2		
6	16 x 64	2048	112	2048	1 1 1 1 0 0 0 0	2112	113
			97	1088	See Note 2		
			96	1024	1 1 1 0 0 0 0 0		
5	16 x 32	1024	81	544	See Note 2	1056	97
			80	512	1 1 0 1 0 0 0 0		
			65	272	See Note 2		
4	16 x 16	256	64	256	1 1 0 0 0 0 0 0	264	65
			49	136	See Note 2		
			48	128	1 0 1 1 0 0 0 0		
3	16 x 8	128	33	68	See Note 2	132	49
			32	64	1 0 1 0 0 0 0 0		
			1	2	See Note 2		
2	16 x 4	64	0	0	1 0 0 0 0 0 0 0	66	33
			0	0	See Note 2		
			0	0	1 0 0 0 0 0 0 0		
1 ↓	32 x 2					1	1

Notes:

- 4096 normalized value units correspond to $TMAX = 3.14 \text{ dBm0}$.
- The character signals are obtained by inverting the even bits of the signals of column 6. Before this inversion, the character signal corresponding to positive input values between two successive decision values numbered n and $n+1$ (see column 4) is $128+n$, expressed as a binary number.
- The value at the decoder output is $y_n = \frac{x_{n-1} + x_n}{2}$, for $n = 1, \dots, 127, 128$.
- x_{128} is a virtual decision value.
- Bit 1 is a 0 for negative input values.

Table 3. μ -Law: Positive Input Values

1	2	3	4	5	6	7	8
Segment Number	# Intervals x Interval Size	Value at Segment End Points	Decision Value Number n	Decision Value x_n (See Note 1)	Character Signal pre Inversion of Even Bits	Quantized Value (at Decoder Output) y_n	Decoder Output Value No.
					Bit No. 1 2 3 4 5 6 7 8		
8	16 x 256	8159	(128)	(8159)	-----	8031	127
			127	7903	1 0 0 0 0 0 0 0		
7	16 x 128	4063	113	4319	See Note 2	4191	112
			112	4063	1 0 0 0 1 1 1 1		
6	16 x 64	2015	97	2143	See Note 2	2079	96
			96	2015	1 0 0 1 1 1 1 1		
5	16 x 32	991	81	1055	See Note 2	1023	80
			80	991	1 0 1 0 1 1 1 1		
4	16 x 16	479	65	511	See Note 2	495	64
			64	479	1 0 1 1 1 1 1 1		
3	16 x 8	223	49	239	See Note 2	231	48
			48	223	1 1 0 0 1 1 1 1		
2	16 x 4	95	33	103	See Note 2	99	32
			32	95	1 1 0 1 1 1 1 1		
1	15 x 2	31	17	35	See Note 2	33	16
			16	31	1 1 1 0 1 1 1 1		
↓	1 x 1	31	2	3	See Note 2	2	1
			1	1	1 1 1 1 1 1 1 0		
			0	0	1 1 1 1 1 1 1 1	0	0

Notes:

- 8159 normalized value units correspond to $TMAX = 3.17 \text{ dBm0}$.
- The character signal corresponding to positive input values between two successive decision values numbered n and $n+1$ (see column 4) is $255-n$, expressed as a binary number.
- The value at the decoder is $y_0 = x_0 = 0$ for $n = 0$, and $y_n = \frac{x_{n+1} + x_n}{2}$, for $n = 1, 2, \dots, 127$.
- x_{128} is a virtual decision value.
- Bit 1 is a 0 for negative input values.

APPLICATIONS

The QSLAC device performs a programmable codec/filter function for four telephone lines. It interfaces to the telephone lines through an Legerity SLIC device or a transformer with external buffering. The QSLAC device provides latched digital I/O to control and monitor four SLICs and provides access to time-critical information, like off/on-hook and ring trip, for all four channels via a single read operation. When various country or transmission requirements must be met, the QSLAC device enables a single SLIC design for multiple applications. The line characteristics (such as apparent impedance, attenuation, and hybrid balance) can be modified by programming each QSLAC device channel's coefficients to meet desired performance. The QSLAC device requires an external buffer to drive transformer SLICs.

Connection to a PCM back plane is implemented by means of a simple buffer chip. Several QSLAC devices can be tied together in one bus interfacing the back plane through a single buffer. An intelligent bus interface chip is not required because each QSLAC device provides its own buffer control (TSXA/B). The QSLAC device is controlled through the microprocessor interface, either by a microprocessor on the linecard or by a central processor.

Controlling the SLIC

The Am79Q021 QSLAC device has five TTL-compatible I/O pins (CD1, CD2, C3 to C5) for each channel. The Am79Q031 QSLAC device has only CD1 and CD2 available. The outputs are programmed using Command 19, and the status is read back using Command 20. CD1 and CD2 for all four channels can be read back using Command 16. The direction of the I/O pins (input or output) is specified by programming the SLIC I/O direction register (Commands 21 and 22).

Default Filter Coefficients

The default filter coefficients were calculated assuming an Am7920 SLIC with 50 Ω protection resistors, a 178 k Ω transversal impedance (Z_T), and a 90.5 k Ω receive impedance (Z_{RX}). This SLIC has a transmit gain of 0.5 (G_{TX}) and a current gain of 500 (K1). The transmit relative level was set to +0.28 dBr, and the receive

relative level was set to -4.39 dBr. The equalization filters (X and R) were not optimized. The balance filter was designed to give acceptable balance into a variety of impedances. The nominal input impedance was set to 815 Ω . If the SLIC circuit differs significantly from this design, the default filters cannot be used and must be replaced by programmed coefficients.

Calculating Coefficients with WinSLAC Software

The WinSLAC software is a program that models the QSLAC device, the line conditions, the SLIC, and the linecard components to obtain the coefficients of the programmable filters of the QSLAC device and some of the transmission performance plots.

The following parameters relating to the desired line conditions and the components/circuits used in the linecard are to be provided as input to the program:

1. Line impedance or the balance impedance of the line is specified by the local PTT.
2. Desired two-wire impedance that is to appear at the linecard terminals of the exchange.
3. Tabular data for templates describing the frequency response and attenuation distortion of the design.
4. Relative analog signal levels for both the transmit and receive two-wire signals.
5. Component values and SLIC device selection for the analog portion of the line circuits.
6. Two-wire return loss template is usually specified by the local PTT.
7. Four-wire return loss template is usually specified by the local PTT.

The output from the WinSLAC program includes the coefficients of the GR, GX, Z, R, X, and B filters as well as transmission performance plots of two-wire return loss, receive and transmit path frequency responses, and four-wire return loss.

The software supports the use of the Legerity SLICs or allows entry of a SPICE netlist describing the behavior of any type of SLIC circuit.

PHYSICAL DIMENSIONS

PL032

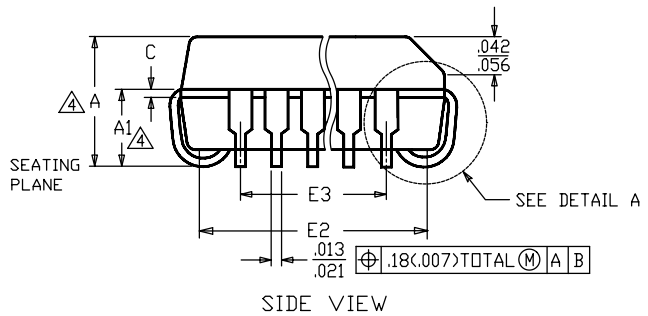
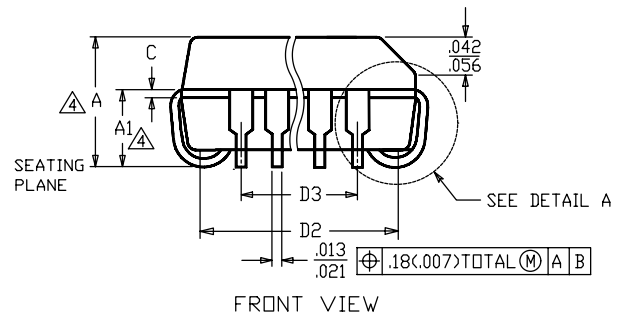
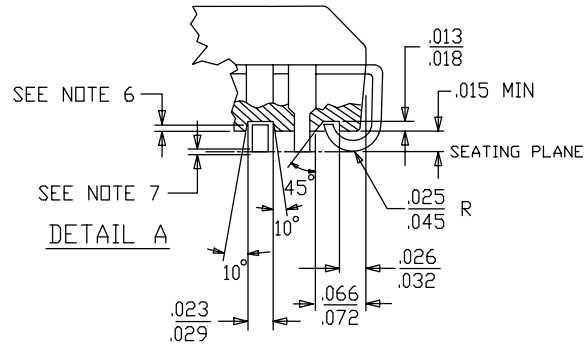
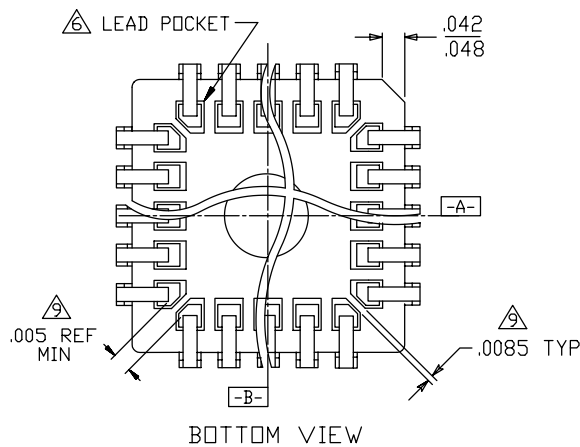
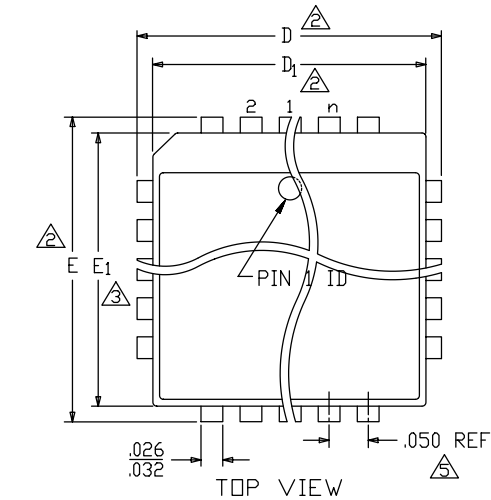

PACKAGE	PL32	
JEDEC	MO-052(A)AE	
SYMBOL	MIN	MAX
A	.125	.140
A1	.080	.095
D	.485	.495
D1	.447	.453
D2	.390	.430
D3	.300	REF
E	.585	.595
E1	.547	.553
E2	.490	.530
E3	.400	REF
C	.009	.015

NOTES:

Dwg rev AH; 10/99

- ALL DIMENSIONS ARE IN INCHES.
- DIMENSIONS "D" AND "E" ARE MEASURED FROM OUTERMOST POINT.
- DIMENSIONS D1 AND E1 DO NOT INCLUDE CORNER MOLD FLASH. ALLOWABLE CORNER MOLD FLASH IS .010"
- DIMENSIONS "A", "A1", "D2" AND "E2" ARE MEASURED AT THE POINTS OF CONTACT TO BASE PLANE
- LEAD SPACING AS MEASURED FROM CENTERLINE TO CENTERLINE SHALL BE WITHIN $\pm .005$ ".
- J-LEAD TIPS SHOULD BE LOCATED INSIDE THE "POCKET".
- LEAD COPLANARITY SHALL BE WITHIN .004" AS MEASURED FROM SEATING PLANE. COPLANARITY IS MEASURED PER AMD 06-500.
- LEAD TWEAZE SHALL BE WITHIN .0045" ON EACH SIDE AS MEASURED FROM A VERTICAL FLAT PLANE. TWEAZE IS MEASURED PER AMD 06-500.
- LEAD POCKET MAY BE RECTANGULAR (AS SHOWN) OR OVAL. IF CORNER LEAD POCKETS ARE CONNECTED THEN 5 MILS MINIMUM CORNER LEAD SPACING IS REQUIRED.

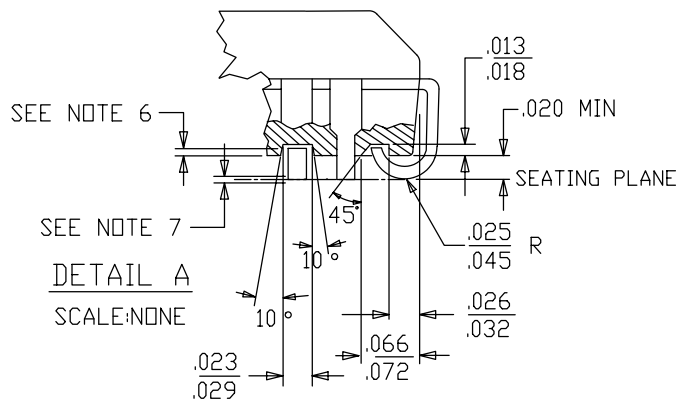
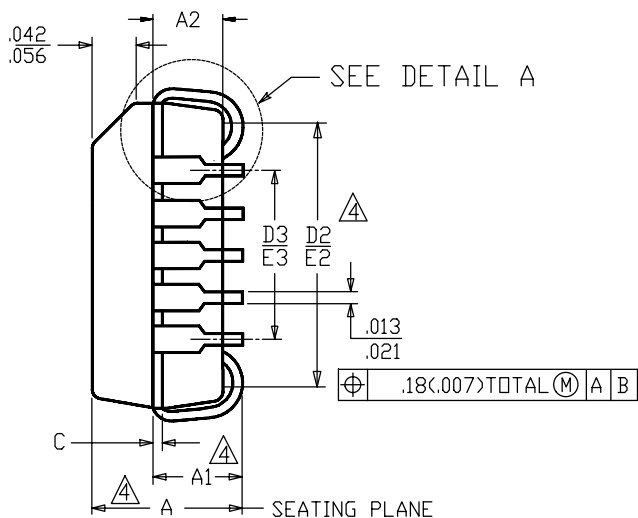
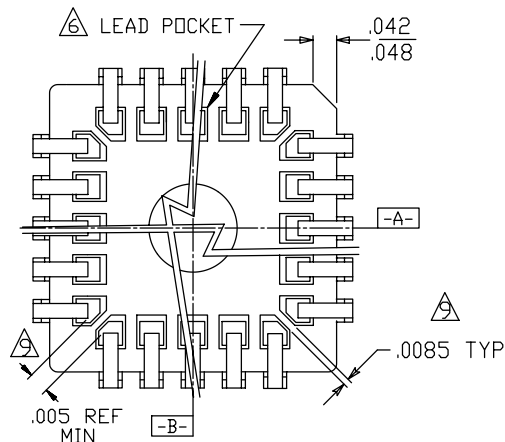
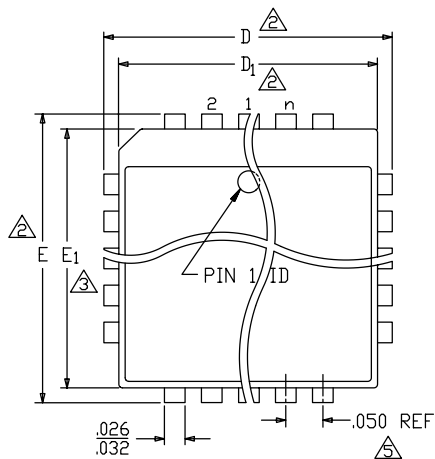

Dwg rev. AN; 8/99

PACKAGE	PL44	
JEDEC SYMBOL	MIN	MAX
	MS-018(A)AC	
A	.165	.180
A1	.090	.120
A2	.062	.083
D	.685	.695
D1	.650	.656
D2	.590	.630
D3	.500	REF
E	.685	.695
E1	.650	.656
E2	.590	.630
E3	.500	REF
C	.009	.015

NOTES: (UNLESS OTHERWISE SPECIFIED)

- ALL DIMENSIONS ARE IN INCHES.
- DIMENSIONS "D" AND "E" ARE MEASURED FROM OUTERMOST POINT.
- DIMENSIONS D1 AND E1 DO NOT INCLUDE CORNER MOLD FLASH. ALLOWABLE CORNER MOLD FLASH IS .010 INCH.
- DIMENSIONS "A", "A1", "D2" AND "E2" ARE MEASURED AT THE POINTS OF CONTACT TO BASE PLANE.
- LEAD SPACING AS MEASURED FROM CENTERLINE TO CENTERLINE SHALL BE WITHIN ±.005 INCH.
- J-LEAD TIPS SHOULD BE LOCATED INSIDE THE "POCKET".
- LEAD COPLANARITY SHALL BE WITHIN .004 INCH AS MEASURED FROM SEATING PLANE. COPLANARITY IS MEASURED PER AMD 06-500.
- LEAD TWEEZE SHALL BE WITHIN .0045 INCH ON EACH SIDE AS MEASURED FROM A VERTICAL FLAT PLANE. TWEEZE IS MEASURED PER AMD 06-500.
- LEAD POCKET MAY BE RECTANGULAR (AS SHOWN) OR OVAL. IF CORNER LEAD POCKETS ARE CONNECTED THEN 5 MILS MINIMUM CORNER LEAD SPACING IS REQUIRED.

PQT044

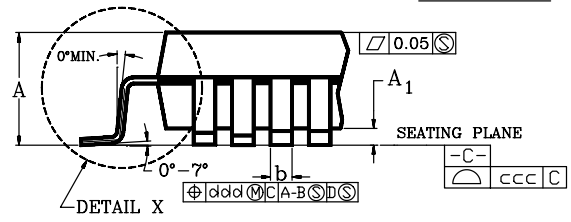
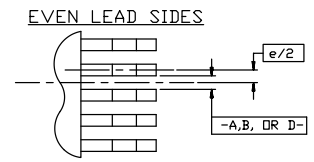
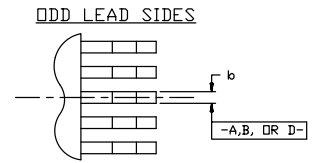
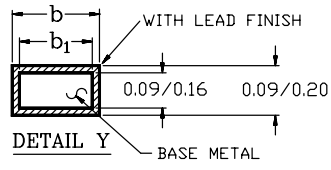
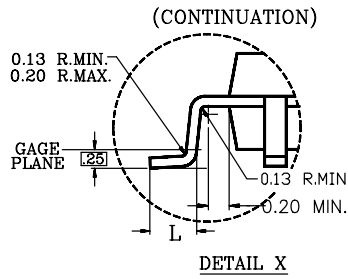
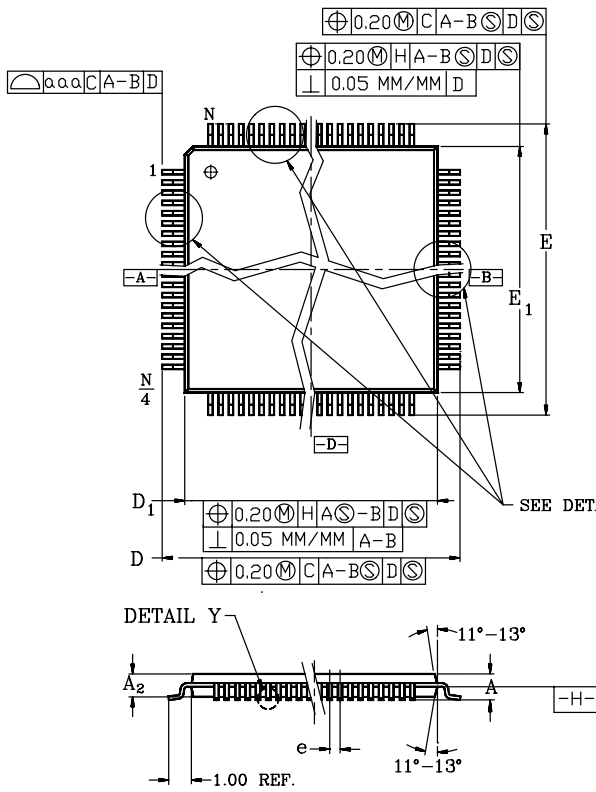

Dwg rev AS; 08/99

PACKAGE	PQT 44		
JEDEC	MS-026 (C) ACB		
SYMBOL	MIN	NOM	MAX
A	—	—	1.20
A1	0.05	—	0.15
A2	0.95	1.00	1.05
D	12.00 BSC		
D1	10.00 BSC		
E	12.00 BSC		
E1	10.00 BSC		
L	0.45	0.60	0.75
N	44		
e	0.80 BASIC		
b	0.30	0.37	0.45
b1	0.30	0.35	0.40
ccc	—	—	0.10
ddd	—	—	0.20
aaa	—	—	0.20

NOTES:

- ALL DIMENSIONS AND TOLERANCES CONFORM TO ANSI Y14.5M-1982.
- DATUM PLANE $-H-$ IS LOCATED AT THE MOLD PARTING LINE AND IS COINCIDENT WITH THE BOTTOM OF THE LEAD WHERE THE LEAD EXITS THE PLASTIC BODY.
- DIMENSIONS "D1" AND "E1" DO NOT INCLUDE MOLD PROTRUSION. ALLOWABLE PROTRUSION IS 0.254mm PER SIDE. DIMENSIONS "D1" AND "E1" INCLUDE MOLD MISMATCH AND ARE DETERMINED AT DATUM PLANE $-H-$
- DIMENSION "B" DOES NOT INCLUDE DAMBAR PROTRUSION. ALLOWABLE DAMBAR PROTRUSION SHALL BE 0.08 mm TOTAL IN EXCESS OF THE b DIMENSION AT MAXIMUM MATERIAL CONDITION. DAMBAR CAN NOT BE LOCATED ON THE LOWER RADIUS OR THE FOOT.
- CONTROLLING DIMENSIONS: MILLIMETER.
- DIMENSIONS "D" AND "E" ARE MEASURED FROM BOTH INNERMOST AND OUTERMOST POINTS.
- DEVIATION FROM LEAD-TIP TRUE POSITION SHALL BE WITHIN ± 0.076 mm.
- LEAD COPLANARITY SHALL BE WITHIN 0.10 mm. COPLANARITY IS MEASURED PER SPECIFICATION 06-500.
- HALF SPAN (CENTER OF PACKAGE TO LEAD TIP) SHALL BE $15.30 \pm .165$ mm.
- "N" IS THE TOTAL NUMBER OF TERMINALS.
- THE TOP OF PACKAGE IS SMALLER THAN THE BOTTOM OF THE PACKAGE BY 0.15 mm.
- THIS OUTLINE CONFORMS TO JEDEC PUBLICATION 95 REGISTRATION MO-136, MS-026.

REVISION SUMMARY

Revision B to Revision C

- In the *Connection Diagrams* section, “INT” was changed to “ $\overline{\text{INT}}$ ” for Am79Q021JC and Am79Q021VC.
- “Frame sync” information was added to the first paragraph on page 31.

Revision C to Revision D

- Minor changes were made to the data sheet style and format to conform to Legerity standards.
- Deleted the Am79Q02VC package and all references to it.
- The physical dimensions (PL032, PL044, and PQT044) were added to the Physical Dimensions section.
- In the Pin Description table, the second sentence was deleted from the MCLK/E1 row and the second to last sentence was deleted from the PCLK row.
- On page 20, row 29 was deleted.
- On pages 23–24, the reference to “29” was deleted.
- In the *Clock Mode Operation* section on page 25, the second to last sentence was deleted.

Revision D to Revision E

- Page 59, Table 3, changed values in column 7.

Revision E to Revision F

- All the physical dimensions were updated.

Revision F to Revision G

- Page 28, deleted “Old Flag (CMD 47, Bit 0)” from Figure 9.
- Page 53, “47. Read Transmit PCM Data”. Changed last row, last column from OLD to RSVD. Deleted text “Old Data Flag...”
- Electrical characteristics table: “pk” added to units for I_{out}.

Revision G to Revision H

- In the “Functional Description” section, deleted “VC” as an option for the Am79Q02 QSLAC device in the table listing the different configurations available.

Notes:

www.legerity.com

Legerity provides silicon solutions that enhance the performance, speeds time-to-market, and lowers the system cost of our customers' products. By combining process, design, systems architecture, and a complete set of software and hardware support tools with unparalleled factory and worldwide field applications support, Legerity ensures its customers enjoy a smoother design experience. It is this commitment to our customers that places Legerity in a class by itself.

The contents of this document are provided in connection with Legerity, Inc. products. Legerity makes no representations or warranties with respect to the accuracy or completeness of the contents of this publication and reserves the right to make changes to specifications and product descriptions at any time without notice. No license, whether express, implied, arising by estoppel or otherwise, to any intellectual property rights is granted by this publication. Except as set forth in Legerity's Standard Terms and Conditions of Sale, Legerity assumes no liability whatsoever, and disclaims any express or implied warranty, relating to its products including, but not limited to, the implied warranty of merchantability, fitness for a particular purpose, or infringement of any intellectual property right.

Legerity's products are not designed, intended, authorized or warranted for use as components in systems intended for surgical implant into the body, or in other applications intended to support or sustain life, or in any other application in which the failure of Legerity's product could create a situation where personal injury, death, or severe property or environmental damage may occur. Legerity reserves the right to discontinue or make changes to its products at any time without notice.

© 2001 Legerity, Inc.
All rights reserved.

Trademarks

Legerity, the Legerity logo and combinations thereof, DSLAC, QSLAC, SLAC, and WinSLAC are trademarks of Legerity, Inc.

Other product names used in this publication are for identification purposes only and may be trademarks of their respective companies.

Americas

ATLANTA

6465 East Johns Crossing, Suite 400
Duluth, GA USA 30097
MainLine: 770-814-4252
Fax: 770-814-4253

AUSTIN

4509 Freidrich Lane
Austin, TX USA 78744-1812
MainLine: 512-228-5400
Fax: 512-228-5510

BOSTON

6 New England Executive Park Suite 400
Burlington, MA USA 01803
MainLine: 781-229-7320
Fax: 781-272-3706

CHICAGO

8770 W. Bryn Mawr, Suite 1300
Chicago, IL USA 60631
MainLine: 773-867-8034
Fax: 773-867-2910

DALLAS

4965 Preston Park Blvd., Suite 280
Plano, TX USA 75093
MainLine: 972-985-5474
Fax: 972-985-5475

HUNTSVILLE

600 Boulevard South, Suite 104
Huntsville, AL USA 35802
MainLine: 256-705-3504
Fax: 256-705-3505

IRVINE

1114 Pacifica Court, Suite 250
Irvine, CA USA 92618
MainLine: 949-753-2712
Fax: 949-753-2713

NEW JERSEY

3000 Atrium Way, Suite 270
Mt. Laurel, NJ USA 08054
MainLine: 856-273-6912
Fax: 856-273-6914

OTTAWA

600 Terry Fox Drive
Ottawa, Ontario, Canada K26 4B6
MainLine: 613-599-2000
Fax: 613-599-2002

RALEIGH

2500 Regency Parkway, Suite 226
Cary, NC USA 27511
MainLine: 919-654-6843
Fax: 919-654-6781

SAN JOSE

1740 Technology Drive, Suite 290
San Jose, CA USA 95110
MainLine: 408-573-0650
Fax: 408-573-0402



Mailing: P.O. Box 18200
Austin, TX 78760-8200
Shipping: 4509 Freidrich Lane
Austin, TX 78744-1812

Telephone: (512) 228-5400
Fax: (512) 228-5510
North America Toll Free: (800) 432-4009

Worldwide Sales Offices

Asia

HONG KONG

Units 2401-2, 24th Floor
Jubilee Centre, 18 Fenwick Street
Wanchai, Hong Kong
MainLine: 852-2864-8300
Fax: 852-2866-1323

KOREA

135-090 18th Fl., Kyoung Am Bldg
157-26, Samsung-dong, Kangnam-ku
Seoul, Korea
MainLine: 82-2-565-5951
Fax: 82-2-565-3788

SHANGHAI

Shanghai P.O. Box 232022
Shanghai PR China 200232
MainLine: 86-21-54233253
Fax: 86-21-54233254

SHENZHEN

Room 310, Tower 9
Jinxu Street 30 Futian District
Shenzhen, PR China 518040
MainLine: 86-755-3706-667
Fax: 86-755-3706-520

SINGAPORE

Serangoon Central Post Office
P.O. Box 537
Singapore 915502
MainLine: 65-2803267
Fax: 65-2855869

TOKYO

Shinjuku NS Bldg. 5F
2-4-1 Nishi Shinjuku, Shinjuku-ku
Tokyo, Japan 163-0805
MainLine: 81-3-5339-2011
Fax: 81-3-5339-2012

Europe

BELGIUM

Baron Ruzettelaan 27
8310 Brugge
Belgium
MainLine: 32-50-28-88-10
Fax: 32-50-27-06-44

FRANCE

7, Avenue G. Pompidou
Suite 402
92300 Levallois-Perret, France
MainLine: 33-1-47-48-2206
Fax: 33-1-47-48-2568

GERMANY

Elisabethstrasse 89-91
80797 München, Germany
MainLine: 49-89-5908-0
Fax: 49-89-5908-1308

ITALY

Via F. Rosselli 3/2
20019 Settimo Mse, Milano Italy
MainLine: 39-02-3355521
Fax: 39-02-33555232

SWEDEN

Frösundaviks Allé 15, 4tr
SE-16970 Solna
Sweden
MainLine: 46-8-509-045-45
Fax: 46-8-509-046-36

UK

Regus House, Windmill Hill Business Park
Whitehill Way
SN5 6QR Swindon
Wiltshire UK
MainLine: 44-(0)1793-441408
Fax: 44-(0)1793-441608

To download or order product literature, visit our website at www.legerity.com.

To order literature in North America, call: (800) 572-4859 or 512-349-3193
or email: americallit@legerity.com

To order literature in Europe or Asia, call: 44-0-1179-341607
or email: Europe — eurolit@legerity.com
Asia — asialit@legerity.com