

BiCMOS CURRENT MODE PWM CONTROLLERS

FEATURES

- Low Power BiCMOS Design
- Tough CMOS™ Construction
- Low Supply Current 1.0mA Typ @ 100kHz
- Wide Supply Voltage Operation 8V to 15V
- Latch-Up Immunity 500mA on Outputs
- Input Will Withstand Negative Inputs to - 5 Volts
- High Output Drive 0.7A Peak
(1.2A on 14-Pin and 16-Pin Versions)
- 2 kV ESD Protection
- Current Mode Control
- Fast Rise/Fall Time (Max) 60nsec @ 1000pF
- High Frequency Operation 500kHz
- Clock Ramp Reset Current 2.5mA ±10%
- Low Propagation Delay Current Amp to Output 140nsec Typ.
- Pin Compatible with UC3843

ORDERING INFORMATION

Part No.	Package	Temperature
TC18C43MJA	8-Pin CerDIP	- 55°C to +125°C
TC18C43MJD	14-Pin CerDIP	- 55°C to +125°C
TC28C43EOE	16-Pin SOIC (Wide)	- 40°C to +85°C
TC28C43EPA	8-Pin Plastic DIP	- 40°C to +85°C
TC28C43EPD	14-Pin Plastic DIP	- 40°C to +85°C
TC38C43COE	16-Pin SOIC (Wide)	0°C to +70°C
TC38C43CPA	8-Pin Plastic DIP	0°C to +70°C
TC38C43CPD	14-Pin Plastic DIP	0°C to +70°C

PIN CONFIGURATIONS

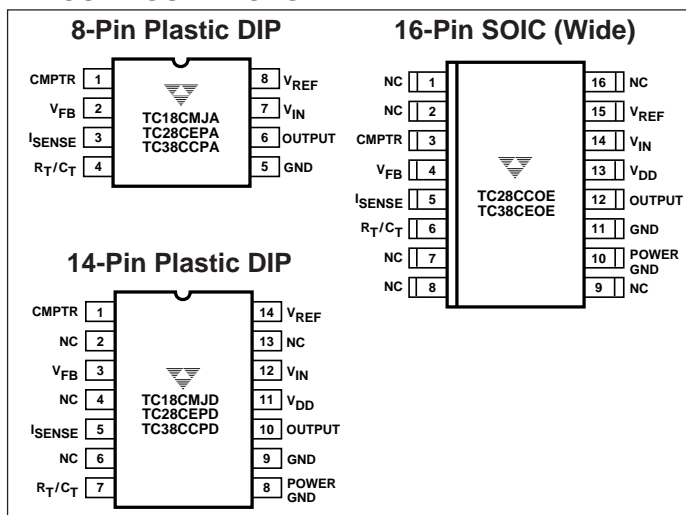

GENERAL DESCRIPTION

The TC38C43 is a current mode BiCMOS PWM control IC. With a low 1.0 mA supply current along with high drive current (0.7A peak) it provides a low cost solution for a PWM that operates to 500 kHz and directly drives MOSFETs up to HEX 3 size.

Performance of the oscillator and current sense amplifier have been greatly improved over previous bipolar versions. Voltage and temperature stability have been improved by a factor of 3. Noise immunity (PSRR) has also been improved.

The TC38C43 is pin compatible with the earlier bipolar version so that designers can easily update older designs. Improvements have been added, though. For example, clock ramp reset current is specified at 2.5mA (±10%) for accurate dead time control. A few component values must be changed (R_T & C_T) to use the TC38C43 in existing bipolar designs.

The 14-pin DIP and 16-pin SOIC versions have separate and internally isolated grounds, and are rated for higher output current (1.2A). These separate grounds allow for 'bootstrap' operation of the PWM to further improve efficiency.

FUNCTIONAL BLOCK DIAGRAM

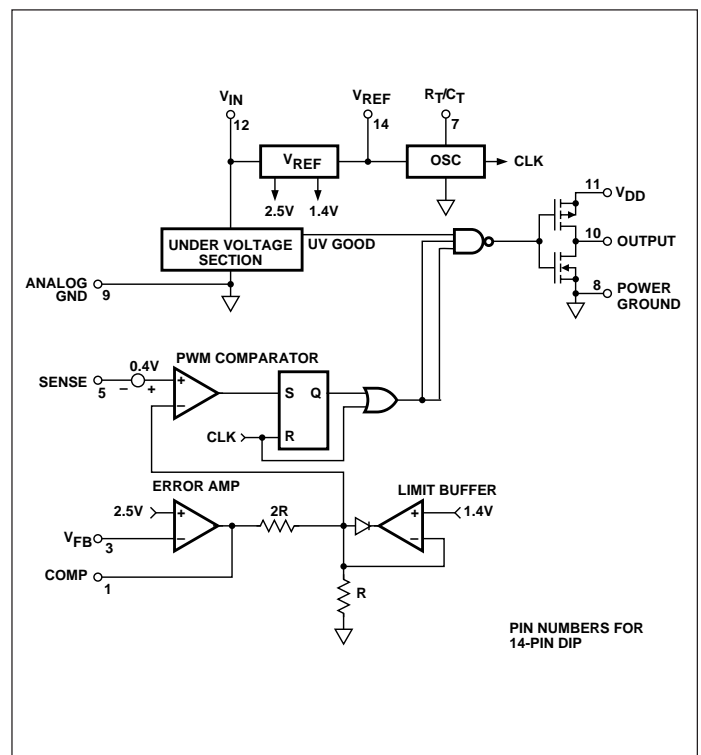

TC18C43 TC28C43 TC38C43

ABSOLUTE MAXIMUM RATINGS*

Supply Voltage	18V
Maximum Chip Temperature	150°C
Storage Temperature	- 65°C to +150°C
Lead Temperature (Soldering, 10 sec)	+300°C
Package Thermal Resistance	
CerDip R _{θJ-A}	150°C/W
CerDip R _{θJ-C}	55°C/W

PDIP R _{θJ-A}	125°C/W
PDIP R _{θJ-C}	45°C/W
SOIC R _{θJ-A}	250°C/W
SOIC R _{θJ-C}	75°C/W
Operating Temperature	
18C4x	- 55°C ≤ T _A ≤ +125°C
28C4x	- 40°C ≤ T _A ≤ +85°C
38C4x	0°C ≤ T _A ≤ +70°C

ELECTRICAL CHARACTERISTICS unless otherwise stated, these specifications apply over specific temperature range. V_{IN} = V_{DD} = 15V; R_T = 71 kΩ; C_T = 150 pF.

Parameter	Test Conditions	TC18C43 TC28C43			TC38C43			Units
		Min	Typ	Max	Min	Typ	Max	
Reference Section								
Output Voltage	T _A = 25°C, I _O = 1mA	4.9	5	5.1	4.90	5	5.10	V
Line Regulation	9.5V ≤ V _{IN} ≤ 15V, I _O = 1mA	—	±3	±10	—	±3	±10	mV
Load Regulation	1mA ≤ I _O ≤ 11mA	—	±5	±15	—	±3	±10	mV
Temp Stability	(Note 1)	—	±0.25	±0.5	—	±0.25	±0.5	mV/°C
Output Noise Voltage	10Hz ≤ f ≤ 10 kHz, T _A = 25°C (Note 1)	—	100	—	—	100	—	μV(rms)
Long Term Stability	T _A = 125°C, 1000 Hrs. (Note 1)	—	±0.5	—	—	±0.5	—	%
Output Short Circuit		-20	-50	-100	-30	-50	-100	mA
Oscillator Section								
Initial Accuracy	T _A = 25°C (Note 4)	90	100	110	93.8	100	106.5	kHz
Voltage Stability	9.5V ≤ V _{IN} ≤ 15V	—	±0.2	±0.3	—	±0.2	±0.3	%
Temp Stability	T _{MIN} ≤ T _A ≤ T _{MAX} (Note 1); Figure 2	—	±0.01	±0.05	—	±0.01	±0.03	%/°C
Clock Ramp Reset	R _T /C _T Pin at 4V	2.25	2.5	2.75	2.25	2.5	2.75	mA
Amplitude	R _T /C _T Pin Peak to Peak	2.45	2.65	2.85	2.45	2.65	2.85	V
Maximum Freq	Note 1	1	—	—	1	—	—	MHz
Error Amp Section								
Input Offset Voltage	V _(CMPTR) = 2.5V	—	±15	±50	—	±15	±50	mV
Input Bias Current	(Note 1)	—	±0.3	±2	—	±0.3	±2	nA
A _{VOL}	2V ≤ V _O ≤ 4V	70	90	—	70	90	—	dB
Gain Bandwidth Product	(Note 1)	650	750	—	650	750	—	kHz
PSRR	9.5V ≤ V _{IN} ≤ 15V	80	100	—	80	100	—	dB
Output Sink Current	V _{FB} = 2.7V, V _(CMPTR) = 1.1V (Note 1)	1.2	1.5	—	1.5	1.7	—	mA
Output Source Current	V _{FB} = 2.3V, V _(CMPTR) = 5V (Note 1)	3	3.4	—	3.9	4.2	—	mA
V _{OUT} High	V _{FB} = 2.3V, R _L = 10k to Ground	5.65	6	6.5	5.65	6	6.5	V
V _{OUT} Low	V _{FB} = 2.7V, R _L = 10k to V _{REF}	0.1	0.7	1.1	0.1	0.7	1.1	V
Rise Response	Note 1	—	5	7	—	5	7	μsec
Fall Response	Note 1	—	3	5	—	3	5	μsec
Current Sense Section								
Gain Ratio	Notes 2 & 3	2.8	2.9	3.1	2.8	2.9	3.1	V/V
Maximum Input Signal	V _(CMPTR) = 5V (Note 2)	0.85	0.95	1.05	0.85	0.95	1.05	V
PSRR	9.5V ≤ V _{IN} ≤ 15V (Notes 1, 2 & 5)	70	80	—	70	80	—	dB
Input Bias Current	Note 1	—	±0.3	±2	—	±0.3	±2	nA
Delay to Output	V _(ISENSE) = 1V (Note 1); Figure 3	—	140	160	—	140	150	nsec

ELECTRICAL CHARACTERISTICS (Cont): unless otherwise stated, these specifications apply over specified temperature range. $V_{IN} = V_{DD} = 15V$; $R_T = 71\text{ k}\Omega$; $C_T = 150\text{ pF}$.

Parameter	Test Conditions	TC18C4X TC28C4X			TC38C4X			Units
		Min	Typ	Max	Min	Typ	Max	
Output Section								
$R_{DS(ON)}$	$I_{SINK} = 20\text{mA}$	—	7	15	—	7	15	Ω
$R_{DS(ON)}$	$I_{SOURCE} = 20\text{mA}$	—	11	20	—	11	15	Ω
Rise Time	$C_L = 1\text{nF}$ (Note 1)	—	40	60	—	35	60	nsec
Fall Time	$C_L = 1\text{nF}$ (Note 1)	—	30	60	—	30	40	nsec
Cross Conduction	In Coulombs (Note 1)	—	6.5	—	—	6.5	—	nC
V_{DD} Ma	Note 1	—	—	18	—	—	18	V
Undervoltage Lockout Section								
Start Threshold	x8C43	7.9	8.4	8.8	7.9	8.4	8.8	V
Undervoltage Threshold	x8C43	7.2	7.6	7.9	7.2	7.6	7.9	V
PWM Section								
Maximum Duty Cycle	x8C43 (Note 1)	95	97	100	95	97	100	%
Minimum Duty Cycle				0			0	%
Supply Current								
Start Up	$T_A = 25^\circ\text{C}$, $V_{IN} < V_{UV}$; Figure 1	50	170	300	50	170	300	μA
Operating	$V_{FB} = V(I_{SENSE}) = 0V$; Figure 4		1	2		1	1.5	mA

- NOTES:** 1. These parameters, although guaranteed over the recommended operating conditions, are not tested in production.
2. Parameter measured at trip point of latch.
3. Gain ratio is defined as:

$$\frac{\Delta V_{COMP}}{\Delta V(I_{SENSE})}$$

where $0 \leq V(I_{SENSE}) \leq 0.8V$

4. Output frequency equals oscillator frequency for the x8C43.
5. PSRR of V_{REF} , Error Amp and PWM Comparator combination.

TelCom Semiconductor reserves the right to make changes in the circuitry or specifications detailed in this manual at any time without notice. Minimums and maximums are guaranteed. All other specifications are intended as guidelines only. TelCom Semiconductor assumes no responsibility for the use of any circuits described herein and makes no representations that they are free from patent infringement.

*Static-sensitive device. Unused devices must be stored in conductive material. Protect devices from static discharge and static fields. Stresses above those listed under Absolute Maximum Ratings may cause permanent damage to the device. These are stress ratings only and functional operation of the device at these or any other conditions above those indicated in the operational sections of the specifications is not implied. Exposure to Absolute Maximum Rating Conditions for extended periods may affect device reliability.

PIN DESCRIPTION

Pin No. 8-Pin	Pin No 14-Pin	Pin No 16-Pin	Symbol	Description
	2	1	NC	No Connection
	4	2	NC	No Connection
1	1	3	CMPTR	Compensation of the feedback loop response.
2	3	4	V_{FB}	Feedback of voltage to error amplifier to regulate voltage.
3	5	5	I_{SENSE}	For sensing pass transistor current and terminate drive when current limit threshold is reached at this pin.
4	7	6	R_T/C_T	Capacitor and resistor input to set oscillator frequency of this PWM controller. The resistor is connected from V_{REF} output to R_T/C_T . The capacitor is connected from R_T/C_T to ANALOG GND.

TC18C43 TC28C43 TC38C43

PIN DESCRIPTION (Cont.)

Pin No. 8-Pin	Pin No 14-Pin	Pin No 16-Pin	Symbol	Description
	6	7	NC	No Connection
	13	8	NC	No Connection
		9	NC	No Connection
	8	10	POWER GROUND	Ground return of output driver.
5	9	11	ANALOG GND	For all the low level analog signal returns.
6	10	12	OUTPUT	Output to drive switching transistor gate input.
	11	13	V _{DD}	Supply power input terminal for the output drivers.
7	12	14	V _{IN}	Voltage bias supply of all PWM Controller circuit functions.
8	14	15	V _{REF}	Reference: 5.0 volt output.
		16	NC	No Connection.

REFERENCE SECTION

The reference is a zener-based design with a buffer amplifier to drive the output. It is unstable with capacitances between 0.01μF and 3.3μF. In a normal application a 4.7μF is used. In some lower noise layouts the capacitor can be eliminated entirely.

The reference is active as soon as the 38C4x has power supplied. This is different than its bipolar counterparts, in that the bipolar reference comes on only after the IC has come out of its under voltage mode. Thus, on the 38C4x, the reference pin can not be used as a reset function such as on a soft start circuit.

OSCILLATOR SECTION

The oscillator frequency is set by the combination of a resistor from the reference to the R_T/C_T pin and by a capacitor from this pin to ground. The oscillator is designed to have ramp amplitude from 0.15 to 2.5 volts. This is approximate, as over shoot on the oscillator comparator causes the ramp amplitude to increase with frequency due to comparator delay. Minimum values for C_T and R_T are 33pF and 1kΩ respectively. Maximum values are dependent on leakage currents in the capacitor, not on the input currents to the R_T/C_T pin.

FREQUENCY OF OPERATION

The frequency of oscillation for the TC38C43 is controlled by a resistor to V_{REF} (R_T) and a capacitor to ground (C_T). V_{REF} supplies current through the resistor and charges the capacitor until its voltage reaches the threshold of the upper comparator (≈2.5V). A 2.5mA current is then applied to the capacitor to discharge it to near ground (≈0.15V). The discharge current is then shut off and the cycle repeats. An approximate equation for the frequency of operation is:

$$f_o \approx \frac{1}{R_T C_T} \quad (R_T \text{ in Ohms and } C_T \text{ in Farads})$$

The value of R_T affects the discharge current and the upper and lower comparators each have delays. As R_T gets smaller and as the frequency of operation gets higher, the above equation is no longer valid.

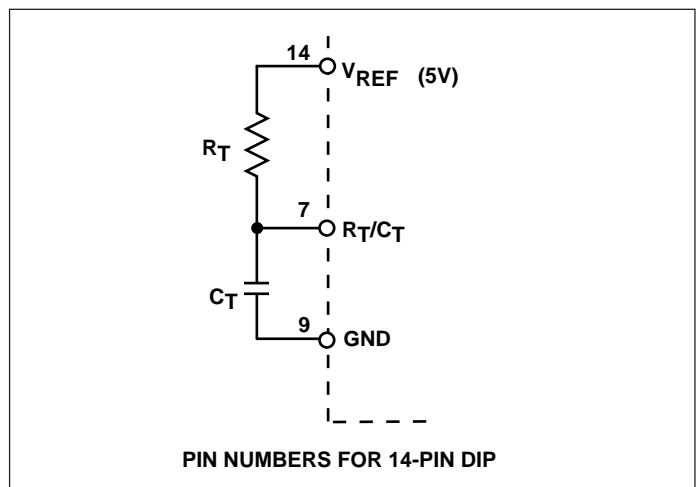

Dead Time

The value of R_T has an effect on the discharge rate but the primary consideration is the value of C_T . The time required to discharge the capacitor is approximately $1000 C_T$.

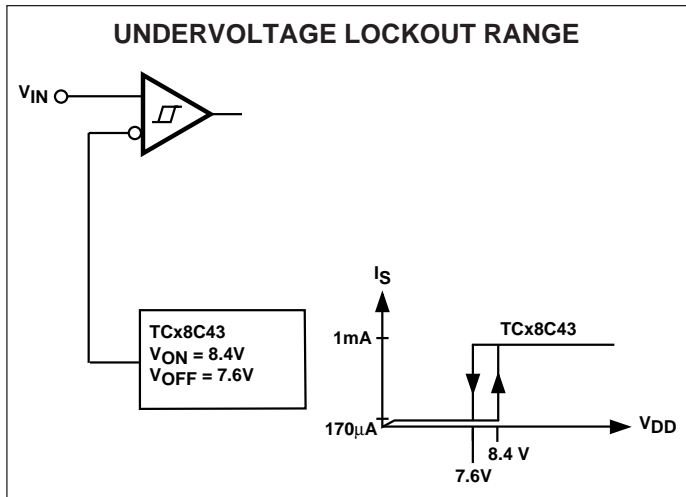

Undervoltage Lockout Range

The TCx8C43 PWM Controller is used where wide ranges of input voltage is not required. The range from starting V_{in} voltage threshold to under voltage threshold is approximately 9.5% of the starting voltage. The typical start-up voltage is 8.4V and dropout voltage is 7.6V. This range is used most in DC-to-DC converter applications.

Duty Cycle Limit

The TCx8C43 PWM Controller has a duty cycle limit maximum of 99%. The oscillator is running at the same frequency as the output.

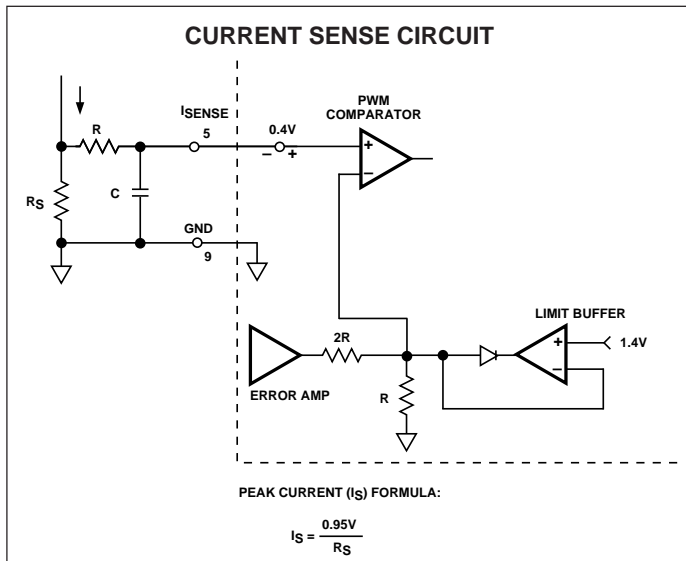

Current is sensed through voltage drop across resistor R_S . A small RC filter may be required to suppress switching transient. This voltage enters PWM Controller at I_{SENSE} , pin 5. A voltage of 0.4V is added before this is fed into PWM Comparator (+) input. The PWM Comparator (-) input senses the voltage feedback error amp output with a limit buffer that limits this voltage to 1.4V maximum. This limit buffer limits the peak current across R_S to a maximum of 0.95V. In normal operation, the error amplifier controls the current limit threshold.

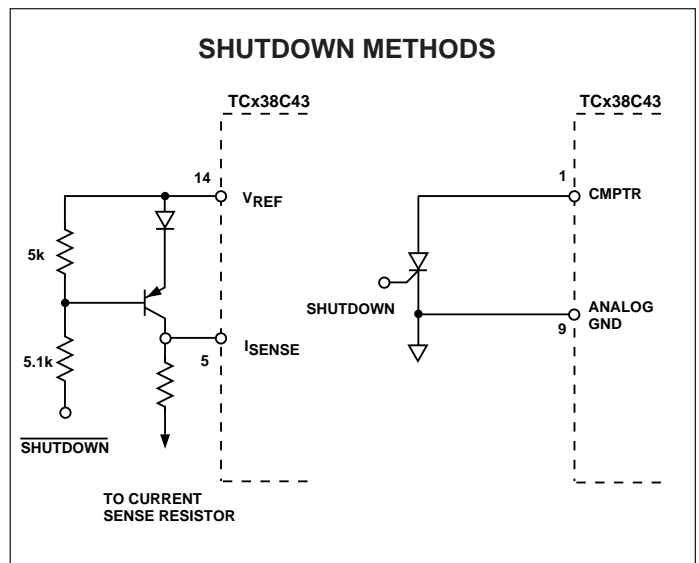

Shutdown can be accomplished by either pulling I_{SENSE} above 1 volt or pulling CMPTR, pin 1 to GND. This will set the PWM latch so that the output will remain low until the next clock pulse after the shutdown condition is removed.

BENCH TEST OPERATIONAL SIMULATION

The timing ramp (R_T/C_T) is buffered by the emitter fullpower and fed back to the I_{SENSE} input. This ramp simulates the di/dt current ramp which would flow through the primary of the transformer. The output voltage of the power supply is simulated by feeding some of the reference voltage into V_{FB} . The combination of the two levels determined the operating characteristics of the current mode controller.

TC18C43
TC28C43
TC38C43

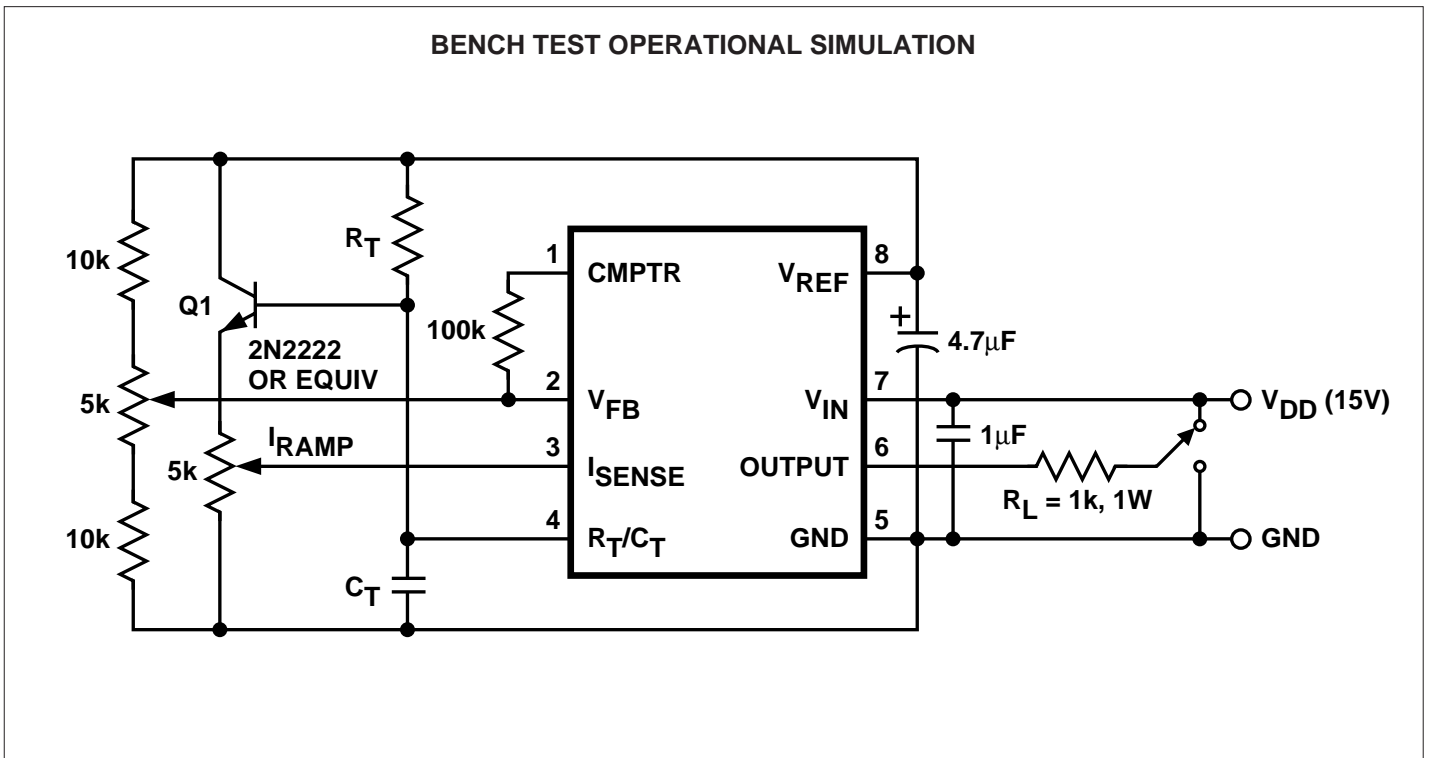

TYPICAL CHARACTERISTICS

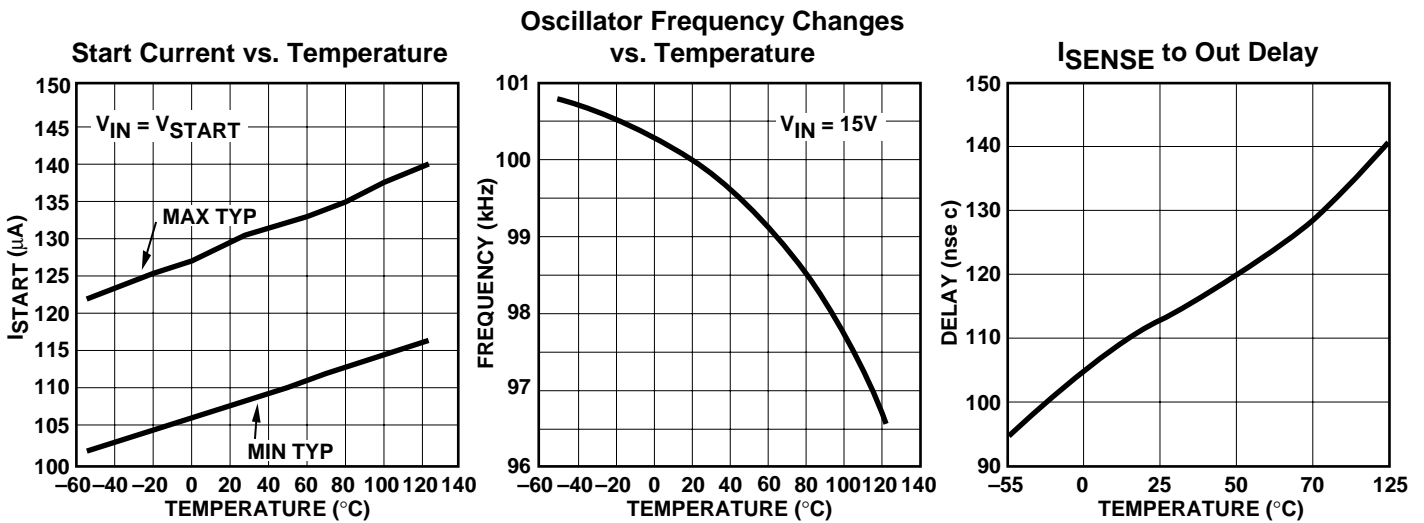

TYPICAL CHARACTERISTICS (Cont.)

