

## Microprocessor Voltage Monitor with Manual Reset

### Features

- Precision monitoring of +3V, +3.3V, and +5V power-supply voltages
- Fully specified over temperature
- Available in two output configurations
  - Push-pull  $\overline{\text{RESET}}$  output (SS8039L)
  - Push-pull RESET output (SS8039H)
- Manual reset input
- Power-on reset pulse width of 140ms min
- Supply current of 5 $\mu$ A
- Guaranteed reset valid to  $V_{CC} = +1V$
- Power supply transient immunity
- No external components
- 4-Pin SOT-143 package

### Applications

- Computers
- Controllers
- Intelligent instruments
- Critical  $\mu$ P and  $\mu$ C power monitoring
- Portable / battery-powered equipment
- Automotive

**Compatible with the popular "811" series**

### General Description

The SS8039 is a microprocessor ( $\mu$ P) supervisory circuit used to monitor the power supplies in  $\mu$ P and digital systems. It provides excellent circuit reliability and low cost by eliminating external components and adjustments when used with +5V, +3.3V, +3.0V- powered circuits.

These circuits perform a single function: they assert a reset signal whenever the  $V_{CC}$  supply voltage declines below a preset threshold, keeping it asserted for at least 140ms after  $V_{CC}$  has risen above the reset threshold. Reset thresholds suitable for operation with a variety of supply voltages are available.

The SS8039 has a push-pull output stage. The SS8039L has an active-low  $\overline{\text{RESET}}$  output, while the SS8039H has an active-high RESET output. The reset comparator is designed to ignore fast transients on  $V_{CC}$ , and the outputs are guaranteed to be in the correct logic state for  $V_{CC}$  down to 1V.

Low supply current makes the SS8039 ideal for use in portable equipment, and it is available in a 4-pin SOT-143 package.

### Pin Configuration

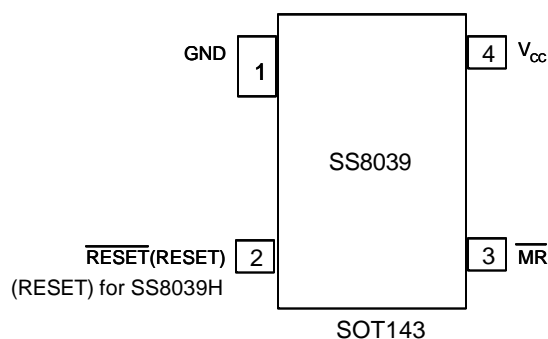

### Typical Application

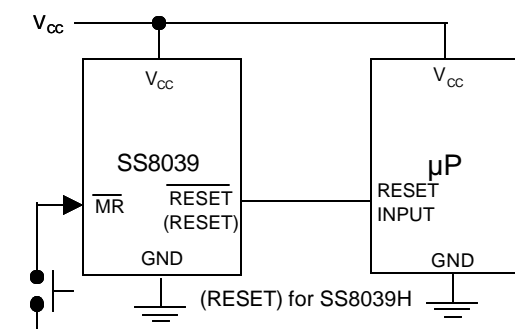

## Ordering Information

Options are released to production as needed. Please check with Silicon Standard for availability.

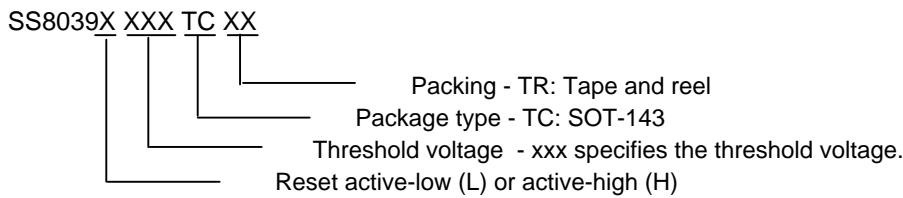

Example: SS8039H263TCTR

SS8039 with push-pull active-high reset output at 2.63V in SOT-143 package supplied on tape and reel

## Absolute Maximum Ratings

Terminal voltages with respect to GND

$V_{CC}$ .....-0.3V to +6.0V  
 RESET,  $\overline{\text{RESET}}$  (push-pull).....-0.3V to ( $V_{CC}$  + 0.3V)  
 Input Current,  $V_{CC}$ .....20mA  
 Output Current, RESET,  $\overline{\text{RESET}}$  .....20mA

Continuous Power Dissipation ( $T_A = +70^\circ\text{C}$ )  
 SOT-143 (derate 4mW/ $^\circ\text{C}$  above +70 $^\circ\text{C}$ ).....320mW  
 Operating Temperature Range .....-40 $^\circ\text{C}$  to +105 $^\circ\text{C}$   
 Storage Temperature Range..... -65 $^\circ\text{C}$  to +150 $^\circ\text{C}$   
 Lead Temperature (soldering, 10s) .....+300 $^\circ\text{C}$

## Electrical Characteristics

( $V_{CC}$  = full range,  $T_A = -40^\circ\text{C}$  to +105 $^\circ\text{C}$ , unless otherwise noted. Typical values are at  $T_A = +25^\circ\text{C}$ ,  $V_{CC} = 5\text{V}$  for 463/438/400 versions,  $V_{CC} = 3.3\text{V}$  for 308/293 versions, and  $V_{CC} = 3\text{V}$  for 263 version.) (Note 1)

PARAMETER	SYMBOL	CONDITION		MIN	TYP	MAX	UNITS
$V_{CC}$ Range		$T_A = 0^\circ\text{C} +70^\circ\text{C}$		1.0		5.5	V
		$T_A = -40^\circ\text{C} +105^\circ\text{C}$		1.2		5.5	
Supply Current	$I_{CC}$	$T_A = -40^\circ\text{C} +105^\circ\text{C}$	$V_{CC} < 5.5\text{V}$ , SS8039x463/438/400		5.5	9	$\mu\text{A}$
			$V_{CC} < 3.6\text{V}$ , SS8039x308/293/263		5	8	
Reset Threshold	$V_{TH}$	SS8039x463	$T_A = +25^\circ\text{C}$	4.537	4.63	4.722	V
		SS8039x438	$T_A = +25^\circ\text{C}$	4.292	4.38	4.467	
		SS8039x400	$T_A = +25^\circ\text{C}$	3.92	4.00	4.08	
		SS8039x308	$T_A = +25^\circ\text{C}$	3.018	3.08	3.141	
		SS8039x293	$T_A = +25^\circ\text{C}$	2.871	2.93	2.988	
		SS8039x263	$T_A = +25^\circ\text{C}$	2.577	2.63	2.682	

**Electrical Characteristics (Continued)**

( $V_{CC}$  = full range,  $T_A$  = -40°C to +105°C, unless otherwise noted. Typical values are at  $T_A$  = +25°C,  $V_{CC}$  = 5V for 463/438/400 versions,  $V_{CC}$  = 3.3V for 308/293 versions, and  $V_{CC}$  = 3V for 263 version.) (Note 1)

PARAMETER	SYMBOL	CONDITION	MIN	TYP	MAX	UNITS
Reset Threshold Tempco				70		ppm/°C
$V_{CC}$ to Reset Delay (Note 2)		$V_{CC} = V_{TH}$ to $(V_{TH} - 100\text{mV})$		15		
Reset Active Timeout Period		$V_{CC} = V_{TH}$ max, SS8039x463/438/400	250	510	720	ms
		$V_{CC} = V_{TH}$ max, SS8039x308/293/263	140	310	520	
$\overline{\text{MR}}$ Minimum Pulse Width	$t_{MR}$			10		μs
$\overline{\text{MR}}$ Glitch Immunity (Note 3)				100		ns
$\overline{\text{MR}}$ to Reset Propagation Delay (Note 2)	$t_{MD}$			0.5		μs
$\overline{\text{MR}}$ Input Threshold	$V_{IH}$	$V_{CC} > V_{TH(\text{max})}$	$0.6 \times V_{CC}$			V
	$V_{IL}$			$0.25 \times V_{CC}$		
$\overline{\text{MR}}$ Pull-up Resistance			10	20	30	KΩ
RESET Output Current Low (push-pull active low, SS8039L)	$I_{OL}$	$V_{CC} = 2.5\text{V}$ , $V_{\overline{\text{RESET}}} = 0.5\text{V}$	8			mA
RESET Output Current High (push-pull active low, SS8039L)	$I_{OH}$	$V_{CC} = 5\text{V}$ , $V_{\overline{\text{RESET}}} = 4.5\text{V}$ , SS8039L463/438/400	4.5			mA
		$V_{CC} = 3.3\text{V}$ , $V_{\overline{\text{RESET}}} = 2.8\text{V}$ , SS8039L308/293	3			
		$V_{CC} = 3\text{V}$ , $V_{\overline{\text{RESET}}} = 2.5\text{V}$ , SS8039L263	2			
RESET Output Current Low (push-pull active high, SS8039H)	$I_{OL}$	$V_{CC} = 5\text{V}$ , $V_{\overline{\text{RESET}}} = 0.5\text{V}$ , SS8039H463/438/400	16			mA
		$V_{CC} = 3.3\text{V}$ , $V_{\overline{\text{RESET}}} = 0.5\text{V}$ , SS8039H308/293	12			
		$V_{CC} = 3\text{V}$ , $V_{\overline{\text{RESET}}} = 0.5\text{V}$ , SS8039H263	10			
RESET Output Current High (push-pull active high, SS8039H)	$I_{OH}$	$V_{CC} = 2.5\text{V}$ , $V_{\overline{\text{RESET}}} = 2\text{V}$	2			mA

Note 1: Production testing done at  $T_A$  = +25°C; limits over temperature guaranteed by design.

Note 2: RESET output is for SS8039L; RESET output is for SS8039H.

Note 3: "Glitches" of 100ns or less typically will not generate a reset pulse.

**Selection Guide and Part Marking**

PART/SUFFIX	RESET THRESHOLD (V)	OUTPUT TYPE	TOP MARK
SS8039H463TC	4.63	Push-Pull RESET	692Lx
SS8039H438TC	4.38	Push-Pull RESET	692Kx
SS8039H400TC	4.00	Push-Pull RESET	692Jx
SS8039H308TC	3.08	Push-Pull RESET	692Ix
SS8039H293TC	2.93	Push-Pull RESET	692Hx
SS8039H263TC	2.63	Push-Pull RESET	692Gx
SS8039L463TC	4.63	Push-Pull $\overline{\text{RESET}}$	692Fx
SS8039L438TC	4.38	Push-Pull $\overline{\text{RESET}}$	692Ex
SS8039L400TC	4.00	Push-Pull $\overline{\text{RESET}}$	692Dx
SS8039L308TC	3.08	Push-Pull $\overline{\text{RESET}}$	692Cx
SS8039L293TC	2.93	Push-Pull $\overline{\text{RESET}}$	692Bx
SS8039L263TC	2.63	Push-Pull $\overline{\text{RESET}}$	692Ax

### Typical Operating Characteristics

( $V_{CC}$  = full range,  $T_A$  =  $-40^{\circ}\text{C}$  to  $+105^{\circ}\text{C}$ , unless otherwise noted. Typical values are at  $T_A$  =  $+25^{\circ}\text{C}$ ,  $V_{CC}$  = 5V for 463/438/400 versions,  $V_{CC}$  = 3.3V for 308/293 versions, and  $V_{CC}$  = 3V for 263 version.)

**Supply Current vs. Temperature  
(No Load)**

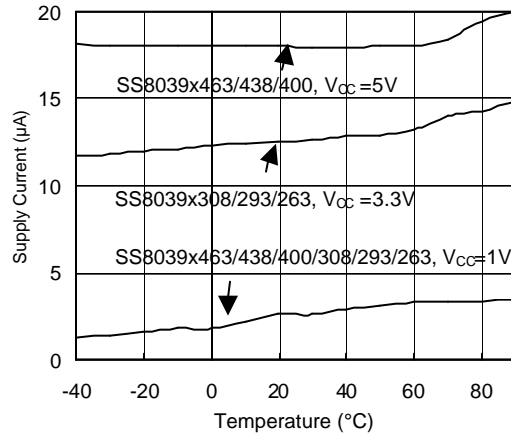

**Power-down Reset Delay vs. Temperature  
(SS8039x308/293/263)**

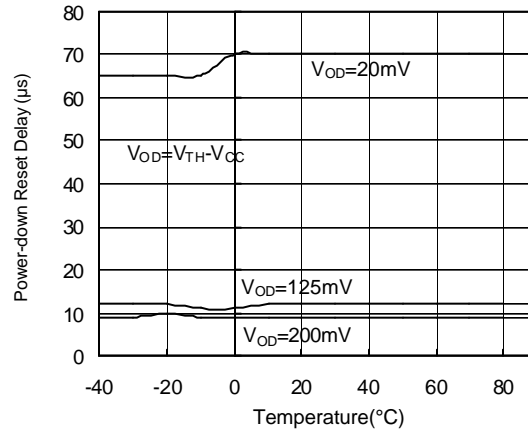

**Power-up Reset Timeout  
vs. Temperature**

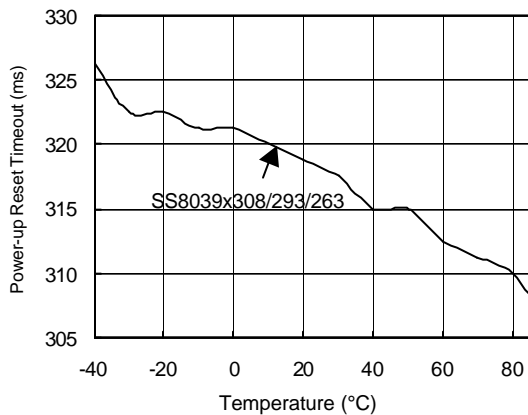

**Normalized Reset Threshold  
vs. Temperature**

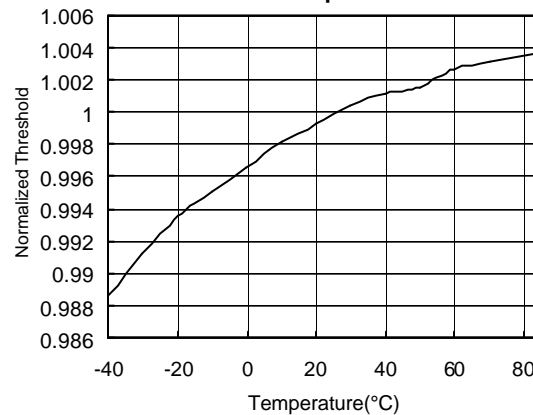

## Pin Description

PIN	NAME	FUNCTION
1	GND	Ground
2	$\overline{\text{RESET}}$ (SS8039L)	$\overline{\text{RESET}}$ Output remains low while $V_{CC}$ is below the reset threshold, and for at least 140ms after $V_{CC}$ rises above the reset threshold.
	RESET (SS8039H)	RESET Output remains high while $V_{CC}$ is below the reset threshold, and for at least 140ms after $V_{CC}$ rises above the reset threshold.
3	$\overline{\text{MR}}$	Manual Reset Input. A logic low on $\overline{\text{MR}}$ asserts reset. Reset remains asserted as long as $\overline{\text{MR}}$ is low and for at least 140ms after $\overline{\text{MR}}$ returns high, This active-low input has an internal 20k $\Omega$ pull-up resistor. It can be driven from a TTL or CMOS-logic line, or shorted to ground with a switch. Leave open if unused.
4	$V_{CC}$	Supply Voltage (+5V, +3.3V, +3.0V)

## Detailed Description

A microprocessor's ( $\mu\text{P}$ 's) reset input starts the  $\mu\text{P}$  in a known state. The SS8039L and SS8039H assert reset to prevent code-execution errors during power-up, power-down, or brownout conditions. They assert a reset signal whenever the  $V_{CC}$  supply voltage declines below a preset threshold, keeping it asserted for at least 140ms after  $V_{CC}$  has risen above the reset threshold.

The SS8039L/SS8039H have a push-pull output stage. The manual reset input (MR) can also initiate a reset. See the Manual Reset Input Section.

### Manual Reset Input

Many  $\mu\text{P}$ -based products require manual reset capability allowing the operator, a test technician, or external logic circuitry to initiate a reset. A logic low on  $\overline{\text{MR}}$  asserts reset. Reset remains asserted while  $\overline{\text{MR}}$  is low, and for the Reset Active Timeout Period ( $t_{RP}$ ) after  $\overline{\text{MR}}$  returns high. This input has an internal 20k $\Omega$  pull-up resistor, so it can be left open if it is not used.  $\overline{\text{MR}}$  can be driven with TTL or CMOS-logic levels, or with open-drain / collector outputs. Connect a normally open momentary switch from  $\overline{\text{MR}}$  to GND to create a manual-reset function; external debounce circuitry is not required. If  $\overline{\text{MR}}$  is driven from long cables or if the device is used in a noisy environment, connecting a 0.1 $\mu\text{F}$  capacitor from  $\overline{\text{MR}}$  to ground provides additional noise immunity.

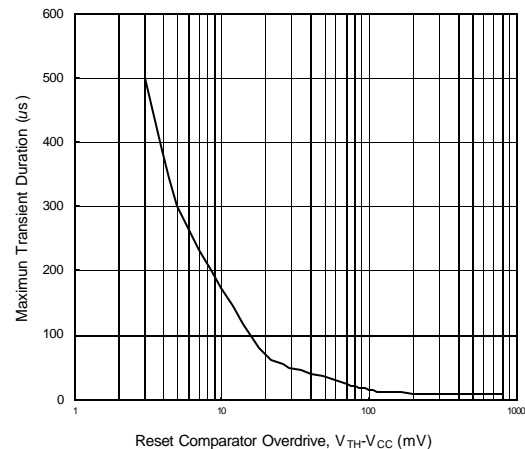

**Fig.1 Maximum Transient Duration Without Causing a Reset Pulse vs. Reset Comparator Overdrive**

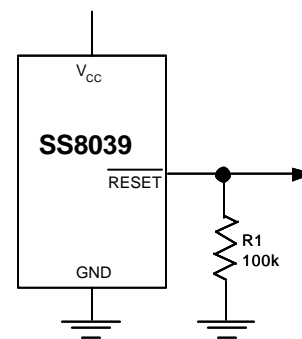

**Figure2.  $\overline{\text{RESET}}$  Valid to  $V_{CC} = \text{Ground}$  Circuit**

## Applications Information

### Negative-Going $V_{CC}$ Transients

In addition to issuing a reset to the  $\mu P$  during power-up, power-down, and brownout conditions, the SS8039H and SS8039L are relatively immune to short-duration negative-going  $V_{CC}$  transients (glitches).

Figure 1 shows typical transient durations, vs. the reset comparator overdrive, for which both the SS8039H and SS8039L do not generate a reset pulse. The graph was generated using a negative-going pulse applied to  $V_{CC}$ , starting 0.5V above the actual reset threshold and ending below it by the magnitude indicated (reset comparator overdrive). The graph indicates the maximum pulse width a negative-going  $V_{CC}$  transient can have without causing a reset pulse. As the magnitude of the transient increases (goes farther below the reset threshold), the maximum allowable pulse width decreases. For the SS8039x463 and SS8039x438, a  $V_{CC}$  transient that goes 100mV below the reset threshold and lasts 15 $\mu s$  or less will not typically cause a reset pulse. A 0.1 $\mu F$  bypass capacitor mounted as close as possible to the  $V_{CC}$  pin provides additional transient immunity.

### Ensuring a Valid Reset Output Down to $V_{CC} = 0$

When  $V_{CC}$  falls below 1V, the SS8039  $\overline{RESET}$  output no longer sinks current—it becomes an open circuit. Therefore, high-impedance CMOS logic inputs connected to  $\overline{RESET}$  can drift to undetermined voltages. This presents no problem in most applications since most  $\mu P$  and other circuitry is inoperative with  $V_{CC}$  below 1V. However, in applications where  $\overline{RESET}$  must be valid down to 0V, adding a pull-down resistor to  $\overline{RESET}$  causes any stray leakage currents to flow to ground, holding  $\overline{RESET}$  low (Figure 2). R1's value is not critical; 100k $\Omega$  is large enough not to load  $\overline{RESET}$  and small enough to pull  $\overline{RESET}$  to ground.

### Benefits of Highly Accurate Reset Threshold

Most  $\mu P$  supervisor ICs have reset threshold voltages between 5% and 10% below the value of nominal supply voltages. This ensures a reset will not occur within 5% of the nominal supply, but will occur when the supply is 10% below nominal.

When using ICs rated at only the nominal supply  $\pm 5\%$ , this leaves a zone of uncertainty where the supply is between 5% and 10% low, and where the reset may or may not be asserted.

The SS8039x uses highly accurate circuitry to ensure that reset is asserted close to the 5% limit, and long before the supply has declined to 10% below nominal.

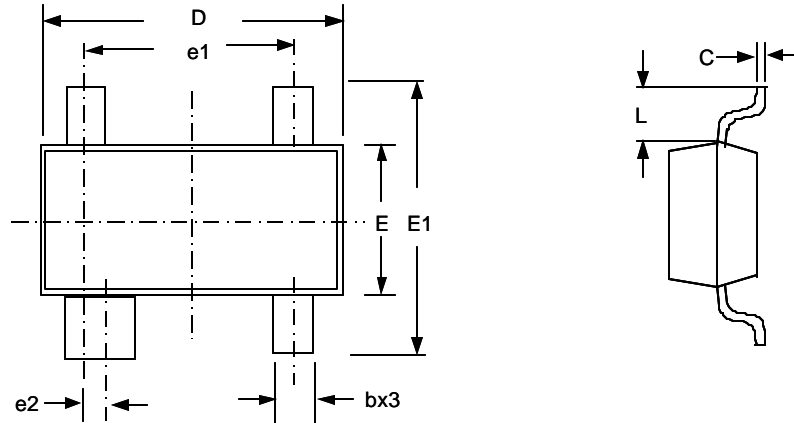
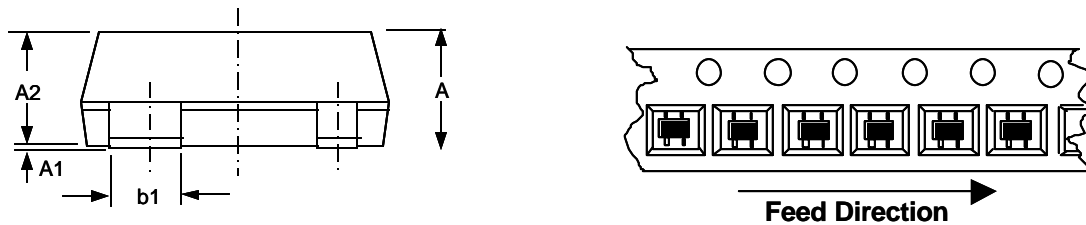
**Physical Dimensions**

**Package Orientation**

**SOT 143 Package**

SYMBOL	DIMENSION IN MILLIMETERS		DIMENSION IN INCHS	
	MIN.	MAX.	MIN.	MAX.
A	0.95	1.20	0.037	0.047
A1	0.05	0.10	0.002	0.004
A2	0.90	1.10	0.035	0.043
b	0.37	0.46	0.145	0.018
b1	0.76	0.89	0.030	0.035
C	0.10	0.18	0.004	0.007
D	2.80	3.04	0.110	0.120
E	1.20	1.40	0.047	0.055
E1	2.30	2.50	0.091	0.098
e1	1.92 BSC.		0.75 BSC.	
e2	0.20 BSC.		0.078 BSC.	
L	0.69 REF.		0.27 REF.	

Information furnished by Silicon Standard Corporation is believed to be accurate and reliable. However, Silicon Standard Corporation makes no guarantee or warranty, express or implied, as to the reliability, accuracy, timeliness or completeness of such information and assumes no responsibility for its use, or for infringement of any patent or other intellectual property rights of third parties that may result from its use. Silicon Standard reserves the right to make changes as it deems necessary to any products described herein for any reason, including without limitation enhancement in reliability, functionality or design. No license is granted, whether expressly or by implication, in relation to the use of any products described herein or to the use of any information provided herein, under any patent or other intellectual property rights of Silicon Standard Corporation or any third parties.