

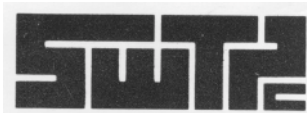

KEYBOARD and ENCODER



219 W. Rhapsody, San Antonio, Texas 78216

KBD-5 KEYBOARD

General Description

The KBD-5 keyboard and ASCII encoder utilizes a single MOS integrated circuit to perform the bulk of all necessary operations to generate full 8 bit parallel ASCII output code complete with a parity bit for error detection. Debounce is internal and automatic and choice between positive or negative keypressed output strobe is provided. The keyboard can be programmed for upper case characters only, or upper and lower case characters. The KBD-5 has the features of n key lockout and 2 key rollover to help in reducing typing errors. Once a key is pressed pressing other keys will have no effect until the first key is released. The KBD-5 is already programmed for the control functions LINE FEED, RETURN and ESCAPE and can easily be programmed for other control functions. The keyboard also has two SPST locking keyswitches which can be used for turning the RECEIVE, TRANSMIT and ECHO functions of a terminal such as the CT-1024 on and off. The keyboard also has an automatic repeat function which causes a string of characters to be transmitted after a key has been depressed for more than about 0.5 seconds.

Assembling your Keyboard and ASCII Encoder

NOTE: MOS integrated circuits are susceptible to damage by static electricity. Although some degree of protection is provided internally within the integrated circuits, their cost demands the utmost in care. Before opening and/or installing any MOS integrated circuits you should ground your body and all metallic tools coming into contact with the leads through a 1M ohm 1/4 watt resistor (supplied with the kit). The ground must be an "earth" ground such as a water pipe, and not the circuit board ground. As for the connection to your body, attach a clip lead to your watch or metal ID bracelet. Make absolutely sure you have the 1M ohm resistor connected between you and the "earth" ground, otherwise you will be creating a dangerous shock hazard. Avoid touching the leads of the integrated circuits any more than necessary when installing them even if you are grounded. On those MOS IC's being soldered in place, the tip of the soldering iron should be grounded as well (separately from your body ground) either with or without a 1 Meg ohm resistor. Most soldering irons having-a three prong line cord already have a grounded tip. Static electricity should be an important consideration in cold, dry environments. It is less of a problem when it is warm and humid.

- () Install the 14 jumpers on the PC board. Use some of the light gauge wire supplied with the kit or excess resistor leads. On the longer jumpers use insulated wire to keep the jumper from shorting to other components. Jumpers are denoted on the circuit board by solid lines connecting two pads. As with all other component installation, unless otherwise noted, pull the jumpers down flush with the circuit board and solder.
- () Install the resistors and capacitors on the circuit board using the component layout on the board and the parts list. Bend the leads over on the back side of the board and trim so that 1/16" to 1/8" of lead remains. Solder.

Scanned and edited by Michael Holley Mar 02, 2002 Revised May 23, 2003 Southwest Technical Products Corporation Document Circa 1975
--

- () Install integrated circuits IC2-IC3 on the board, Be sure to orient the IC's as shown on the board and do not bend the leads on the back side of the board. Doing so makes it very difficult to remove the IC should replacement ever be necessary. Do not install IC1 at this time. Solder.
- () Install the transistor and diodes on the board. Leave about 1/4" clearance between the transistor body and the circuit board. Be sure to orient the components exactly as shown on the component side of the board. Solder.
- () Check the key switches with an ohmmeter before they are installed to be sure that they are making contact properly and to be sure that they do not stick. Solder the switches in place one at a time using as little heat as necessary to get a good solder joint. Note that the keyswitches for the RCVE/XMIT and ECHO positions are a SPST switch and are different from the rest. The switches can be recognized by pressing each keyswitch. The SPST switches will have a locking position. Install these two switches first. Be careful not to force any switch into a hole in such a way as to damage the connecting wires. Excessive heating can distort, or even melt the plastic body and ruin the keyswitch. Check the switch again with an ohmmeter for proper operation after soldering it in place. This can save much troubleshooting later. If the switch works properly heat stake the switch in place by melting over the ends of the plastic mounting bosses. This can be done with the tip of your soldering iron.

After all keyswitches have been installed and checked you are ready to install the programming strips on the bottom of the board. These strips mount vertically, at right angles to the main board. The etched finger, connection points on the programming strips will match the connection pads on the main board when the strips are in the correct position. Hold one of the strips in the correct position and turn it so that the connection fingers match the pads on both sides of the strip. Note that there are two ways the strip may be turned and only one is correct. If the strips edge is too rough to fit down solidly against the main board, file, or sand that edge flat. Hold, or clamp sides of the strip to the main board, pads. Install the other strip in the same way. Both strips are identical.

- () The spacebar and equalizer assembly goes together as follows. Mount a keyswitch on the board in the center of the spacebar area. Mount the two "L" shaped brackets with a notch in the top on each side of the keyswitch in the holes provided. The side of the bracket with the notch should be next to the circuit board edge. These should be fixed in place by melting and flattening slightly the plastic pins on the back of the board with your soldering iron tip. Press one of the equalizer wire retainers into place on the end of the spacebar itself. The hole for the wire should be on the more slanted side of the spacebar that has the four casting bumps. Slip the equalizer wire into the hole in, the retainer you have not yet pressed into place. Press the second retainer into place. Turn the spacebar upside down in front of the board and press the equalizer wire into the notches in the top of the mounting clips. Turn the spacebar over and position it over the keyswitch in the center of the board. Press it down into place.

- () Install IC1 following the precautions given for MOS IC's. Solder.
- () To finish the keyboard assembly snap the plastic key tops on their respective keyswitch as noted on the key configuration drawing. If some of the keytops are loose you can securely fasten them to the switches by using a small amount of plastic cement. Blank keytops may be supplied for the RCVS/XMIT and ECHO positions.

The programming of the "CASE", "PARITY" and the "KEYPRESSED" jumpers depends on what your keyboard will be used for. For upper case characters only connect a jumper from the pad marked "CASE" to "U". For upper plus lower case connect the jumper from the "CASE" pad to "U + L". For a positive keypressed strobe (KP line normally low, goes high when a key is pressed) connect a jumper from the KP pad to "+", for a negative keypressed strobe (KP line normally high, goes low when a key is pressed) connect a jumper from the KP pad to "-". A jumper for "PAR" should also be installed to its respective "U" or "U + L" pad depending on whether upper case or upper plus lower case characters will be used.

Notice to CT-1024 Terminal Owners

In order for the KBD-5 to be used on the CT-1024 terminal the keyboard should be programmed for a negative keypressed strobe (KP select jumper connected to -) and for upper case characters only, ("CASE" jumper connected to U). This is the normal programming for other TV TYPEWRITERS but may need to be modified for your particular application. The parity bit is not used in the CT-1024 but the "PAR" jumper should be connected to "U". The terminals R, T and E of J1 can be connected to control the receive/transmit and echo functions of your CT-1024 if a serial interface is installed. Connect R to JS-1 pin 5, T to JS-1 pin 4 and E to JS-1 pin 8 of the serial interface.

Checkout

The only equipment needed to check the operation of your keyboard is a DC milliammeter and a DC voltmeter. Apply +5 volts, ground, and -12 volts to the proper pins and check for currents of about 4 mA on the -12 line and about 8mA on the +5 line (no keys pressed). If the currents are much higher than this stop immediately and check for parts inserted incorrectly or solder bridges. If the currents check OK check the keypressed output. If the KP select jumper is set for (-) the KP output should be high (4.5V nominal) and go low (0.1 volts nominal) when a key is pressed. If the KP output is held low check for possible solder bridges or a shorted key switch. If the KP select jumper is set for (+) the KP output will be normally low and will go high when a key is pressed. If all seems well refer to the ASCII code tables supplied and check the outputs of bits 1-7 with your voltmeter for each individual character. Be sure to use the correct table depending on how the "CASE" selector is wired on your keyboard. With the "CASE" selector set for the upper case only the SHIFT control will have no effect on the output code when any letter is pressed but will make bit 5 a 0 when any character of column 3 of Table 1 is pressed. When in the upper case only mode the SHIFT key will not affect any of the characters in columns 4 or 5. Pressing the control key forces bit 7 to be a 0 therefore allowing you to select the operators in columns 0 and 1. When in the upper plus lower case mode the SHIFT key makes bit 6 a 1 when letters of columns 4 and 5 of table 2 are pressed and makes bit 5 a 0 when any character of column 3 is selected. The control key operates as before.

This keyboard uses EVEN parity in both the upper case only and the upper plus lower case modes. The parity bit should be low when the number of zeros in the output code is odd and should be high when the number of zeros is even. For example the ASCII code for X, 0001101, should make the parity bit high. The repeat function should be checked by holding any one key down for more than about 1 sec. The keypressed strobe should switch on and off until the key is released. If a faster or slower repeat rate is desired the value of C6 can be changed slightly.

Circuit Description

As shown in figure 1 the keyswitches are arranged into a matrix with the X lines from IC-1 outputting test pulses in time sequence and the Y lines sensing their presence. If no key is pressed, IC-1 continuously scans the keys, at a rate of 50,000 keys per second. Whenever a key is closed, the scanning action stops and that location is held by the internal circuitry of the encoder. This location is called an address. This address is routed to an internal fixed memory called a read only memory. In exchange for an address and some information on the status of the shift and control keys the read only memory gives the proper 8 bit ASCII output code, complete with parity.

As soon as the scanning stops, a time delay is started and controlled by R1 and C1. This takes into account any switch closure bounce or noise and makes sure the key is firmly down and not just brushed on the way by. After the delay time, an output "keypressed" strobe is made available. This tells whatever you attach to your keyboard that the code is ready for use and valid.

If a key is released the scanning action starts up again and goes on till a new key is pressed. If two keys are pressed at nearly the same time the first key pressed provides its output code after a debounce delay. When the first key is released, the scanner starts up but only goes around till it hits the other key's location. After a new debounce delay, the second key's code is output. Keys can continue to be pressed in sequence two down at a time forever, with always the right code being output in sequence, and nothing missed or out of order. This most handy feature takes care of sloppy typing and "burst" rate typing where keys are hit fast and furious in sequence.

IC2 and IC3 are used for the automatic repeat function. IC3 is setup as an astable multivibrator that continuously runs at a frequency of approximately 8.5 Hz. When a key is first pressed the KP line of IN goes high causing an immediate low output of IC2-C. If the key is immediately released no repeat function is initiated. If the key is held down for more than about 1 second C7 will charge to a point where IC2A is triggered. At this time the output of IC3 is NAND'ed with the KP strobe therefore causing the KP signal to be chopped just as if the key was continuously pushed and released. This action will continue until the key is released.

In Case of Problems

The tests called for in the check-out procedure are designed to warn you of problems before they can cause damage. If any abnormal results are obtained during the tests, or if there is obvious overheating of any part discontinue use until the problem is located and corrected. Experience has shown that most problems are caused by minor wiring, component installation and soldering technique errors which can be prevented by careful assembly.

If you do have problems with your keyboard there are several tests you can perform which may help you locate the problem. You will need an ohmmeter, an oscilloscope, and a DC voltmeter for these tests. First go back and check once more for proper component installation and for solder bridges or cold solder joints. Also be sure that the correct jumpers are in place. Next check each keyswitch with an ohmmeter to be sure none are shorted. If you have an oscilloscope apply power to the keyboard and check for a 50 KHz signal on pin 40 of IC-1. If you obtain no signal check for 5 volts on pin 1, -12 on pin 18 and ground on pin 17.

Repair Procedure

Repairs will be made on a basic rate charge plus parts. The basic rate for the KBD-5 is \$10.00. If you must return your KBD-5 please send the \$10.00-in the form of a money order or cashiers check along with the keyboard. When repairs are finished the keyboard will be returned to you COD for parts charges, if any. Do Not send personal checks for repair work.

Pack all parts to be returned carefully and insure. We will not accept delivery on any parcels that arrive in damaged condition. Make check or money order payable to Southwest Technical Products Corporation.

Parts List - KBD-5 Keyboard

Resistors

R1	680K ohm 1/4 watt resistor
R2	100K ohm 1/4 watt resistor
R3	150K ohm 1/4 watt resistor
R4	47K ohm 1/4 watt resistor
R5	10K ohm 1/4 watt resistor
R6	680 ohm 1/4 watt resistor
R7	330 ohm 1/4 watt resistor

Capacitors

C1, C5	0.01 mfd disc capacitor
C2	47 pf polystyrene capacitor
C3, C4	0.1 mfd @16 volt disc capacitor
C6	0.47 mfd tantalum capacitor
C7	220 mfd @6.3 volt electrolytic capacitor

Semiconductors

ICI	2376 Keyboard Encoder (MOS)
IC2	74LS00 quad NAND gate
IC3	555 timer
Q1	2N5210 NPN silicon transistor
D1 - D3	1N4148/1N914 silicon diode

Misc.

J1	15 pin Molex edge connector
S1-S2	Keyboard switch, SPST locking
S3-S56	Keyboard switch
	PC board, programming jumpers (2), Keytops

BIT NUMBERS								b7	0	0	0	0	1	1
								b6	0	0	1	1	0	0
								b5	0	1	0	1	0	1
b7	b6	b5	b4	b3	b2	b1	COLUMN ROW	0	1	2	3	4	5	
			0	0	0	0	0	NUL	DLE	SP	0	@	P	
			0	0	0	1	1	SOH	DC1	!	1	A	Q	
			0	0	1	0	2	STX	DC2	"	2	B	R	
			0	0	1	1	3	ETX	DC3	#	3	C	S	
			0	1	0	0	4	EOT	DC4	\$	4	D	T	
			0	1	0	1	5	ENQ	NAK	%	5	E	U	
			0	1	1	0	6	ACK	SYN	&	6	F	V	
			0	1	1	1	7	BEL	ETB	'	7	G	W	
			1	0	0	0	8	BS	CAN	(8	H	X	
			1	0	0	1	9	HT	EM)	9	I	Y	
			1	0	1	0	10	LF	SUB	*	:	J	Z	
			1	0	1	1	11	VT	ESC	+	;	K	[
			1	1	0	0	12	FF	FS	,	<	L	\	
			1	1	0	1	13	CR	GS	-	=	M]	
			1	1	1	0	14	SO	RS	.	>	N	^	
			1	1	1	1	15	S1	US	/	?	0	_	

Available codes and characters for the UPPER CASE mode
AY-5-2376 Keyboard Encoder

BIT NUMBERS								b7	0	0	0	0	1	1	1	1
								b6	0	0	1	1	0	0	1	1
								b5	0	1	0	1	0	1	0	1
b7	b6	b5	b4	b3	b2	b1	COLUMN ROW	0	1	2	3	4	5	6	7	
			0	0	0	0	0	NUL	DLE	SP	0	@	P	\		
			0	0	0	1	1	SOH	DC1	!	1	A	Q	a	q	
			0	0	1	0	2	STX	DC2	"	2	B	R	b	r	
			0	0	1	1	3	ETX	DC3	#	3	C	S	c	s	
			0	1	0	0	4	EOT	DC4	\$	4	D	T	d	t	
			0	1	0	1	5	ENQ	NAK	%	5	E	U	e	u	
			0	1	1	0	6	ACK	SYN	&	6	F	V	f	v	
			0	1	1	1	7	BEL	ETB	'	7	G	W	g	w	
			1	0	0	0	8	BS	CAN	(8	H	X	h	x	
			1	0	0	1	9	HT	EM)	9	I	Y	i	y	
			1	0	1	0	10	LF	SUB	*	:	J	Z	j	z	
			1	0	1	1	11	VT	ESC	+	;	K	[k	{	
			1	1	0	0	12	FF	FS	,	<	L	\	l		
			1	1	0	1	13	CR	GS	-	=	M]	m	}	
			1	1	1	0	14	SO	RS	.	>	N	^	n	~	
			1	1	1	1	15	S1	US	/	?	0	_	o	DEL	

Available codes and characters for the UPPER PLUS LOWER CASE mode
AY-5-2376 Keyboard Encoder

CONNECT		X0 39	X1 38	X2 37	X3 36	X4 35	X5 34	X6 33	X7 32
TO OBTAIN									
Y0 31	NORMAL	NUL	DLE	-	0	;	l	o	9
	SHIFT	NUL	DLE	=	NUL	+	L	O)
	CONTROL	NUL	DLE	NUL	NUL	NUL	FF	SI	NUL
Y1 30	NORMAL	SOH	K	FS	:	/	k	i	8
	SHIFT	SOH	[FS	*	?	K	I	(
	CONTROL	SOH	VT	FS	NUL	NUL	VT	HT	NUL
Y2 29	NORMAL	STX	L	GS	p	.	j	u	7
	SHIFT	STX	\	GS	P	>	J	U	'
	CONTROL	STX	FF	GS	OLE	NUL	LF	NAK	NUL
Y3 28	NORMAL	ETX	N	RS	_	,	h	y	6
	SHIFT	ETX	^	RS	DEL	<	H	Y	&
	CONTROL	ETX	SO	RS	US	NUL	BS	EM	NUL
Y4 27	NORMAL	EOT	M	US	@	m	g	t	5
	SHIFT	EOT]	US	`	M	G	T	%
	CONTROL	EOT	CR	US	NUL	CR	BEL	DC	NUL
Y5 26	NORMAL	ENQ	NAK	<	BS	n	f	r	4
	SHIFT	ENQ	NAK	<	BS	N	F	R	\$
	CONTROL	ENQ	NAK	NUL	BS	SO	ACK	DC	NUL
Y6 25	NORMAL	ACK	SYN	>	[b	d	e	3
	SHIFT	ACK	SYN	>	{	B	D	E	#
	CONTROL	ACK	SYN	NUL	ESC	STX	EDT	ENQ	NUL
Y7 24	NORMAL	BEL	ETB	,]	v	s	w	2
	SHIFT	BEL	ETB	,	{	V	S	W	"
	CONTROL	BEL	ETB	NUL	GS	SYN	DC	ETB	NUL
Y8 23	NORMAL	DC1	CAN	SP	CR	c	a	q	1
	SHIFT	DC1	CAN	SP	CR	C	A	Q	!
	CONTROL	DC1	CAN	SP	CR	ETX	SOH	DC1	NUL
Y9 22	NORMAL	P	EM	.	LF	x	FF	HT	^
	SHIFT	@	EM	.	LF	X	FF	HT	~
	CONTROL	DLE	EM	NUL	LF	CAN	FF	HT	RS
Y10 21	NORMAL	0	SUB	_	DEL	z	ESC	VT	\
	SHIFT	_	SUB	_	DEL	Z	ESC	VT	:
	CONTROL	SI	SUB	US	DEL	SUB	ESC	VT	FS

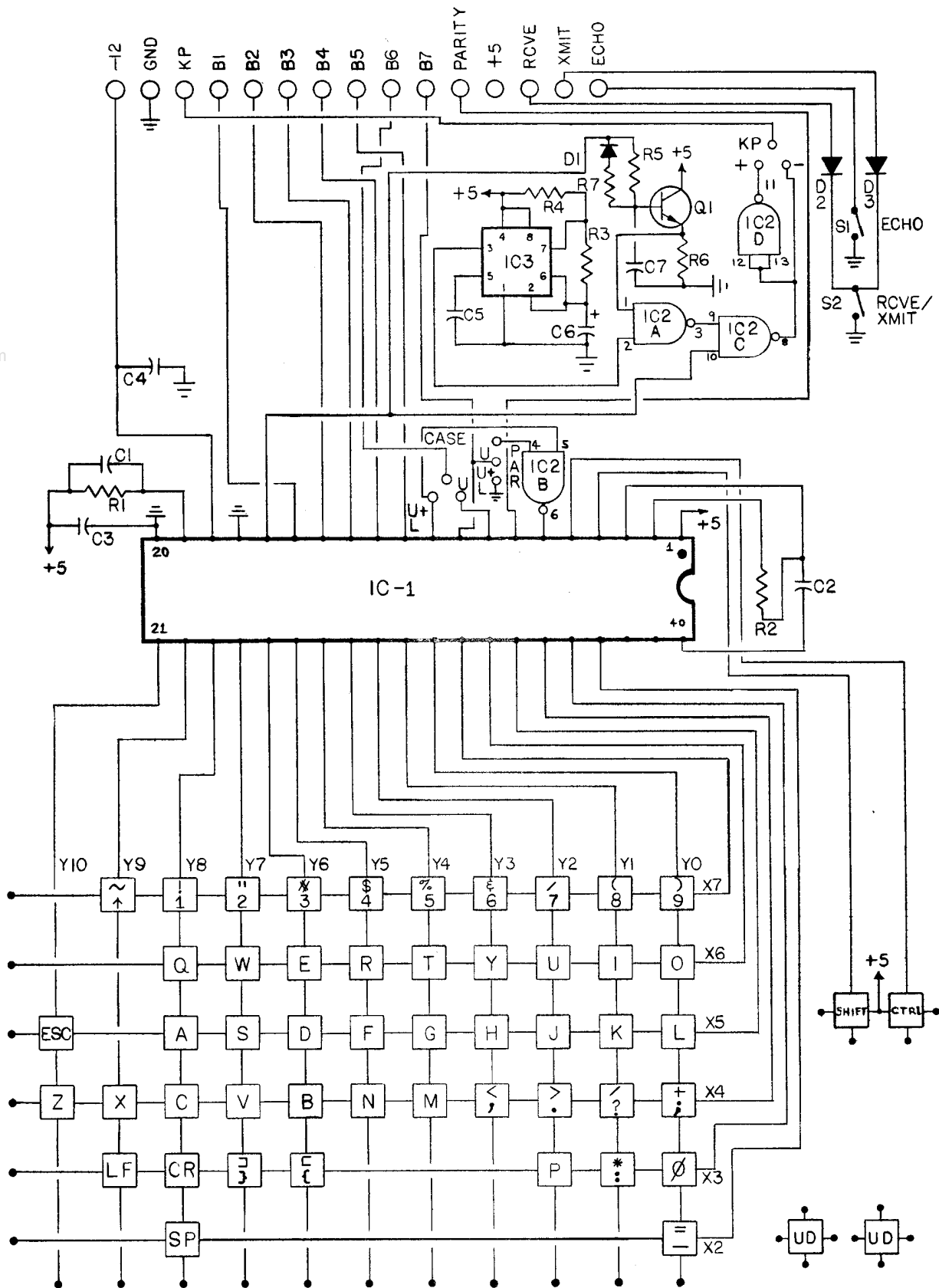

Schematic - KBD - 5 Keyboard and Encoder

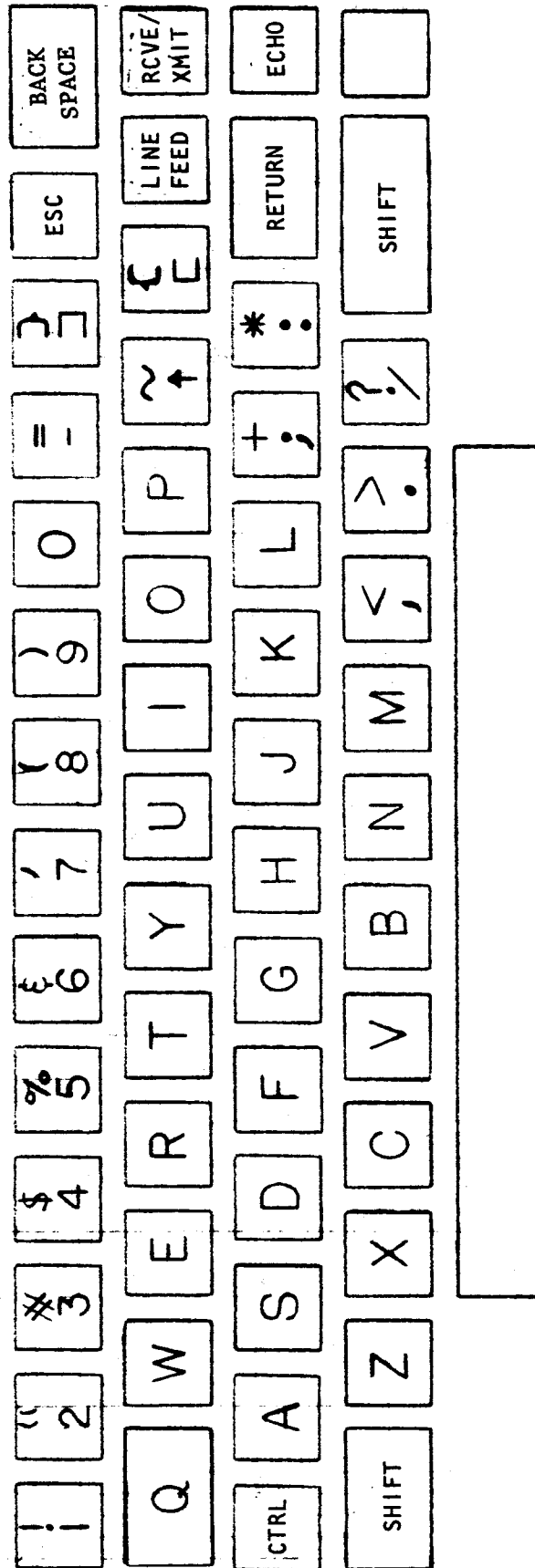

Key Configuration - KBD - 5 Keyboard

Keyboard Modifications

These are the modifications that I did on my CT-1024 System

Back Space

The backspace key is not connected to anything. To generate a BS(08) connect a wire from one pin of the key switch to Y5 (IC1 pin 26). Connect a wire from the other pin of the key-switch to X3 (IC1 pin 36).

At Sign @

To generate an at sign "@" you can change the function of the letter P key. Isolate both pins of the P key-switch. Cut the trace going to the left pin near the switch. Cut the trace for the right pin on both sides of the pin. You will need jumper the right trace around the switch.

Connect a wire from the left pin of the key-switch to Y9 (IC1 pin 22). Connect a wire from the other pin of the key-switch to X0 (IC1 pin 39).

When the shift key is held down the P key will send an @.

Underscore

To generate an under score "_" you can change the function of the letter O key. Isolate both pins of the O key-switch. Cut the trace on the vertical strip near the switch (between the O and I switch). Cut the trace for the right pin on both sides of the pin. You will need jumper the right trace around the switch.

Connect a wire from the left pin of the key-switch to Y10 (IC1 pin 21). Connect a wire from the other pin of the key-switch to X0 (IC1 pin 39).

When the shift key is held down the O key will send a _.