

SERIES UDN-5700A

QUAD 2-INPUT PERIPHERAL/POWER DRIVERS

—Transient-Protected Outputs

FEATURES:

- Four Logic Types
- DTL/TTL/PMOS/CMOS Compatible Inputs
- Low Input Current
- 300 mA Continuous Output Current
- Standoff Voltage of 80 V

Description

THESE 16-LEAD QUAD 2-input peripheral and power drivers are bipolar monolithic integrated circuits containing AND, NAND, OR, or NOR logic gates, high-current switching transistors, and transient-suppression diodes on the same chip. The four output transistors are capable of simultaneously sinking 300 mA continuously at ambient temperatures of up to +70°C. In the OFF state, these drivers will withstand at least 80 V.

Applications

Series UDN-5700A quad drivers are ideally suited for interface between low-level or high-level logic and high-current/high-voltage loads. Typical applications include driving peripheral loads such as incandescent lamps, light-emitting diodes, memories, and heaters.

The integral transient-suppression diodes allow their use with inductive loads such as relays, solenoids, or stepping motors without the need of discrete diodes. For non-inductive loads, the diode-common bus can be used for a convenient lamp test.

ABSOLUTE MAXIMUM RATINGS

Supply Voltage, V_{CC}	7.0 V
Input Voltage, V_{IN}	30 V
Output Off-State Voltage, V_{OFF}	80 V
Output On-State Sink Current, I_{ON}	600 mA
Suppression Diode Off-State Voltage, V_{OFF}	80 V
Suppression Diode On-State Current, I_{ON}	600 mA
Power Dissipation, P_D	2.0 W
Each Driver	0.8 W
Derating Factor Above 25°C	16.7 mW/°C or 60°C/W
Operating Free-Air Temperature Range, T_A	-20°C to +85°C
Storage Temperature Range, T_S	-55°C to +150°C

RECOMMENDED OPERATING CONDITIONS

	Min.	Nom.	Max.	Units
Supply Voltage (V_{CC}):	4.75	5.0	5.25	V
Operating Temperature Range	0	+25	+85	°C
Current into any output (ON state)			300	mA

INPUT PULSE CHARACTERISTICS

$V_{in(0)} = 0V$	$t_r = 7ns$	$t_p = 1\mu s$
$V_{in(1)} = 3.5V$	$t_r = 14ns$	PRR = 500kHz

3

ELECTRICAL CHARACTERISTICS over operating temperature range (unless otherwise noted)

Characteristic	Symbol	Test Conditions				Limits			Units	Notes	
		Temp.	V_{CC}	Driven Input	Other Input	Output	Min.	Typ.			Max.
"1" Input Voltage	$V_{in(1)}$		MIN				2.0			V	
"0" Input Voltage	$V_{in(0)}$		MIN					0.8		V	
"0" Input Current	$I_{in(0)}$		MAX	0.4 V	30 V			-50	-100	μA	2
"1" Input Current	$I_{in(1)}$		MAX	30 V	0 V				10	μA	2
Input Clamp Voltage	V_I		MIN	-12 mA					-1.5	V	

SWITCHING CHARACTERISTICS at $V_{CC} = 5.0 V$, $T_A = 25^\circ C$

Characteristic	Symbol	Test Conditions	Limits			Units	Notes
			Min.	Typ.	Max.		
Turn-on Delay Time	t_{p0}	$V_S = 70 V$, $R_L = 465 \Omega$ (10 Watts) $C_L = 15 pF$		200	500	ns	3
Turn-off Delay Time	t_{p1}	$V_S = 70 V$, $R_L = 465 \Omega$ (10 Watts) $C_L = 15 pF$		300	750	ns	3

NOTES:

1. Typical values are at $V_{CC} = 5.0V$, $T_A = 25^\circ C$.
2. Each input tested separately.
3. Voltage values shown in the test circuit waveforms are with respect to network ground terminal.
4. Capacitance values specified include probe and test fixture capacitance.

Type UDN-5703A Quad OR Driver

ELECTRICAL CHARACTERISTICS over operating temperature range (unless otherwise noted)

Characteristic	Symbol	Test Conditions					Limits			Notes	
		Temp.	V _{CC}	Driven Input	Other Input	Output	Min.	Typ.	Max.		Units
"1" Output Reverse Current	I _{off}		MIN	2.0 V	0 V	80 V			100	μA	
			OPEN	2.0 V	0 V	80 V			100	μA	
"0" Output Voltage	V _{on}		MIN	0.8 V	0.8 V	150 mA	0.35	0.5		V	
			MIN	0.8 V	0.8 V	300 mA	0.5	0.7		V	
Diode Leakage Current	I _{LK}	NOM	NOM	0 V	0 V	OPEN			200	μA	3
Diode Forward Voltage Drop	V _D	NOM	NOM	V _{CC}	V _{CC}		1.5	1.75		V	4
"1" Level Supply Current	I _{CC(1)}	NOM	MAX	5.0 V	5.0 V		16	25		mA	1, 2
"0" Level Supply Current	I _{CC(0)}	NOM	MAX	0 V	0 V		72	100		mA	1, 2

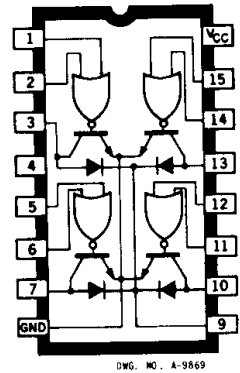
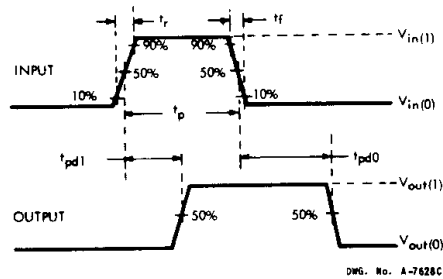
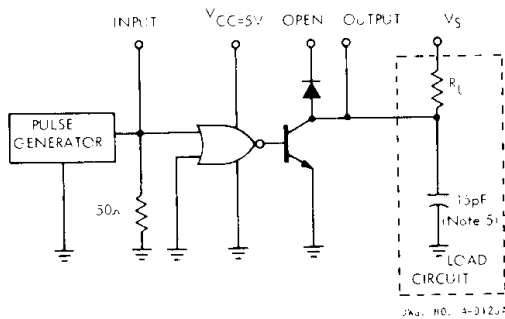

Type UDN-5706A Quad AND Driver

ELECTRICAL CHARACTERISTICS over operating temperature range (unless otherwise noted)

Characteristic	Symbol	Test Conditions					Limits			Notes	
		Temp.	V _{CC}	Driven Input	Other Input	Output	Min.	Typ.	Max.		Units
"1" Output Reverse Current	I _{off}		MIN	2.0 V	2.0 V	80 V			100	μA	
			OPEN	2.0 V	2.0 V	80 V			100	μA	
"0" Output Voltage	V _{on}		MIN	0.8 V	V _{CC}	150 mA	0.35	0.5		V	
			MIN	0.8 V	V _{CC}	300 mA	0.5	0.7		V	
Diode Leakage Current	I _{LK}	NOM	NOM	0 V	0 V	OPEN			200	μA	3
Diode Forward Voltage Drop	V _D	NOM	NOM	V _{CC}	V _{CC}		1.5	1.75		V	4
"1" Level Supply Current	I _{CC(1)}	NOM	MAX	5.0 V	5.0 V		16	24		mA	1, 2
"0" Level Supply Current	I _{CC(0)}	NOM	MAX	0 V	0 V		70	98		mA	1, 2

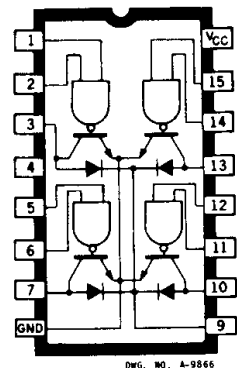
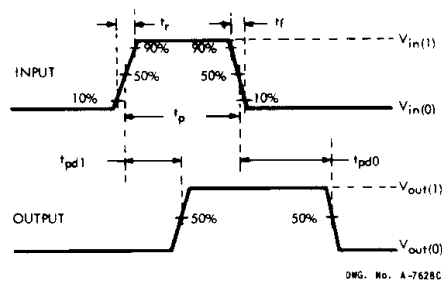
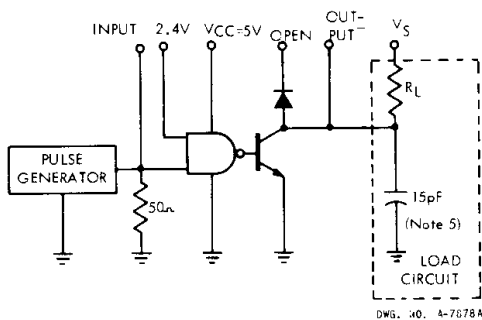

NOTES:

1. Typical values are at V_{CC} = 5.0 V, T_A = 25°C.
2. Per package.
3. Diode leakage current measured at V_R = V_{off(min)}.
4. Diode forward voltage drop measured at I_f = 300 mA.
5. Capacitance values specified include probe and test fixture capacitance.

Type UDN-5707A Quad NAND Driver

ELECTRICAL CHARACTERISTICS over operating temperature range (unless otherwise noted)

Characteristic	Symbol	Test Conditions					Limits				Notes
		Temp.	V _{CC}	Driven Input	Other Input	Output	Min.	Typ.	Max.	Units	
"1" Output Reverse Current	I _{off}		MIN	0.8 V	V _{CC}	80 V			100	μA	
			OPEN	0.8 V	V _{CC}	80 V			100	μA	
"0" Output Voltage	V _{on}		MIN	2.0 V	2.0 V	150 mA	0.35	0.5	V		
			MIN	2.0 V	2.0 V	300 mA	0.5	0.7	V		
Diode Leakage Current	I _{LK}	NOM	NOM	V _{CC}	V _{CC}	OPEN		200	μA	3	
Diode Forward Voltage Drop	V _D	NOM	NOM	0 V	0 V		1.5	1.75	V	4	
"1" Level Supply Current	I _{CC(1)}	NOM	MAX	0 V	0 V		24	30	mA	1, 2	
"0" Level Supply Current	I _{CC(0)}	NOM	MAX	5.0 V	5.0 V		80	106	mA	1, 2	

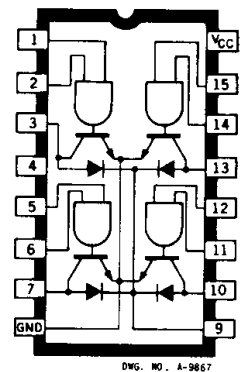
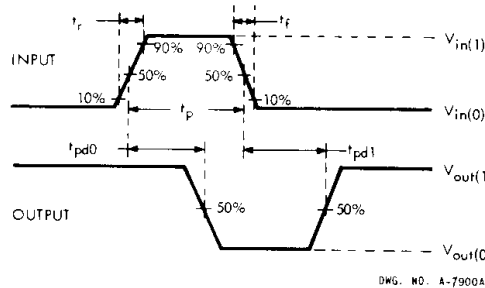
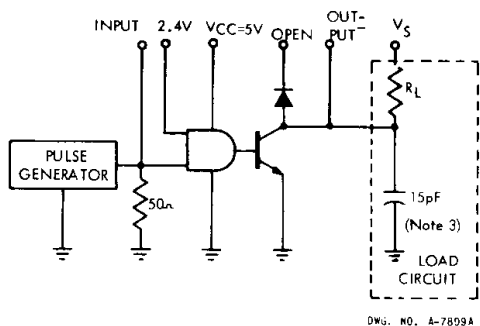

Type UDN-5733A Quad NOR Driver

ELECTRICAL CHARACTERISTICS over operating temperature range (unless otherwise noted)

Characteristic	Symbol	Test Conditions					Limits				Notes
		Temp.	V _{CC}	Driven Input	Other Input	Output	Min.	Typ.	Max.	Units	
"1" Output Reverse Current	I _{off}		MIN	0.8 V	0.8 V	80 V			100	μA	
			OPEN	0.8 V	0.8 V	80 V			100	μA	
"0" Output Voltage	V _{on}		MIN	2.0 V	0 V	150 mA	0.35	0.5	V		
			MIN	2.0 V	0 V	300 mA	0.5	0.7	V		
Diode Leakage Current	I _{LK}	NOM	NOM	V _{CC}	V _{CC}	OPEN		200	μA	3	
Diode Forward Voltage Drop	V _D	NOM	NOM	0 V	0 V		1.5	1.75	V	4	
"1" Level Supply Current	I _{CC(1)}	NOM	MAX	0 V	0 V		24	30	mA	1, 2	
"0" Level Supply Current	I _{CC(0)}	NOM	MAX	5.0 V	5.0 V		80	100	mA	1, 2	

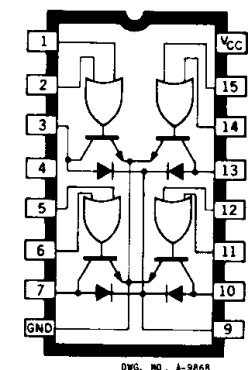
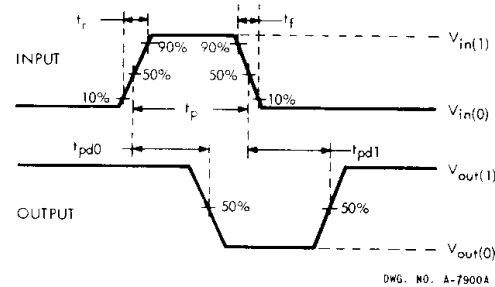
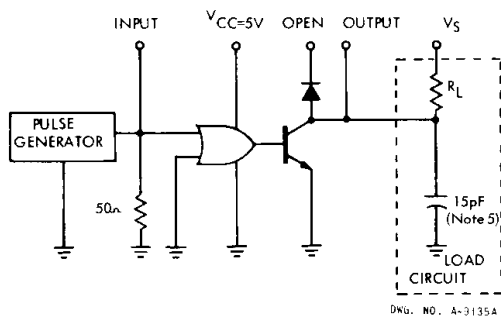

NOTES:

1. Typical values are at V_{CC} = 5.0 V, T_A = 25°C.
2. Per package.
3. Diode leakage current measured at V_R = V_{off(min)}.
4. Diode forward voltage drop measured at I_f = 300 mA.
5. Capacitance values specified include probe and test fixture capacitance.