

DBL 1045

DUAL PREAMPLIFIER FOR AUTO REVERSE

The DBL1045 contains forward/reverse control switches and metal/normal tape equalizer control switches.

FEATURES

- High open loop voltage gain :
 $G_{VO} = 98\text{dB(Typ.)}$ at $V_{CC} = 9\text{V}$, $f = 1\text{KHz}$
- No input coupling capacitor
- Low distortion :
 $\text{THD} = 0.035\%(\text{Typ.})$
at $G_V = 40\text{dB}$, $V_{OUT} = 0.5\text{Vrms}$
- Low equivalent input noise voltage :
 $V_{NI} = 0.9\text{Vrms(Typ.)}$
at $R_g = 620\ \Omega$, $\text{BW} = 20\text{Hz} \sim 20\text{KHz}$, NAB EQ

APPLICATIONS

- Radio cassette, Car stereo

MAXIMUM RATINGS ($T_a = 25^\circ\text{C}$)

Characteristic	Symbol	Rating	Unit
Supply Voltage	V_{CC}	16	V
Power Dissipation*	P_D	750	mW
Operating Temperature	T_{opr}	$-30 \sim +75$	$^\circ\text{C}$
Storage Temperature	T_{stg}	$-55 \sim +150$	$^\circ\text{C}$

* Power dissipation is derated above $T_a = 25^\circ\text{C}$ in the proportion of $6\text{mW}/^\circ\text{C}$

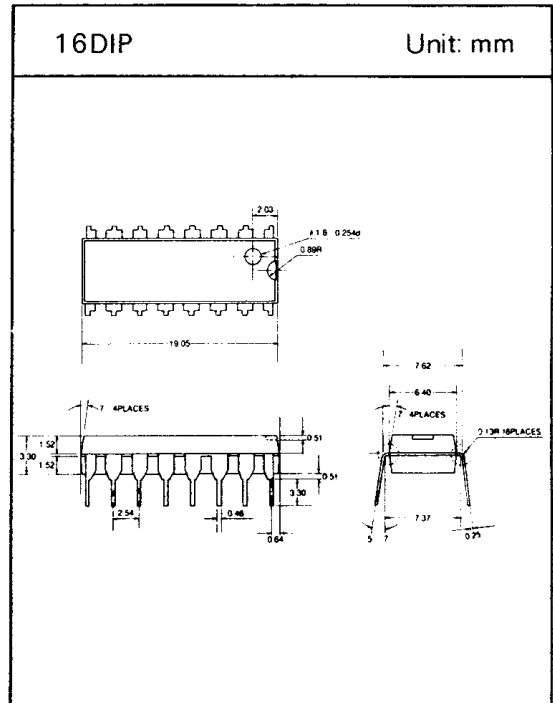

DBL 1045

□ BLOCK DIAGRAM AND TEST CIRCUIT

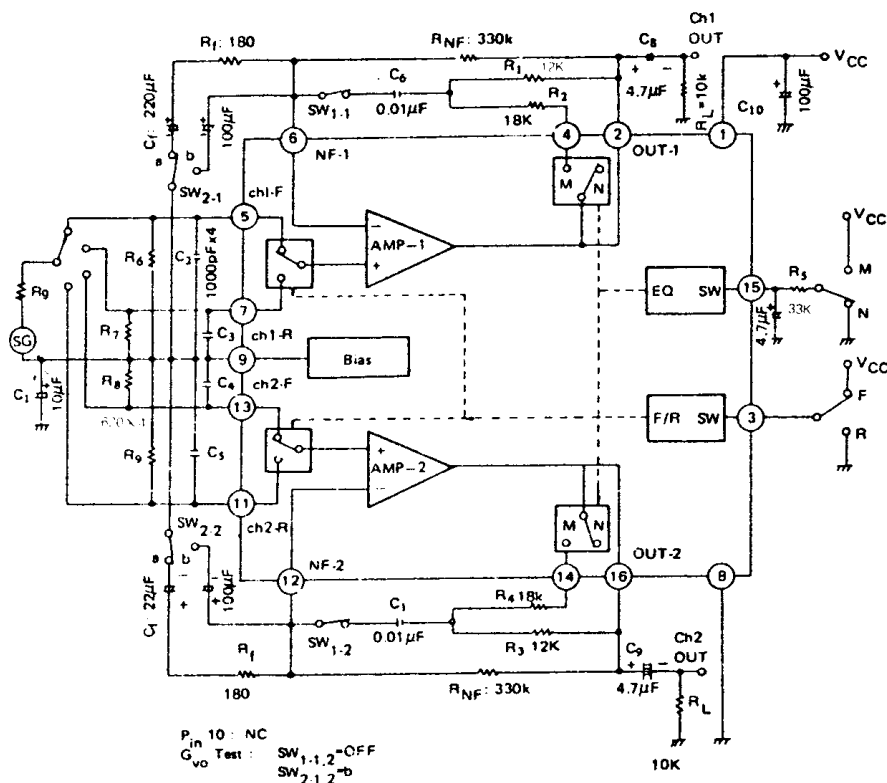

□ ELECTRICAL CHARACTERISTICS

(Unless otherwise specified, $V_{CC} = 9V$, $f = 1KHz$, $R_g = 600\Omega$, $T_a = 25^\circ C$, Normal EQ)

Characteristic	Symbol	Test Condition	Min.	Typ.	Max.	Unit
Quiescent current	I_{CCQ1}	Normal EQ	—	5	—	mA
	I_{CCQ2}	Metal EQ	—	6	9	mA
Open Loop Voltage Gain	G_{VO}	$C_f = 100\mu F$, $R_f = 0$	—	98	—	dB
Maximum Output Voltage	V_{OM}	THD = 0.5%	1.5	2	—	Vrms
Total Harmonic Distortion	THD	$V_{OUT} = 0.5V_{rms}$	—	0.035	0.12	%
Equivalent Input Noise Voltage	V_{NI}	$R_g = 620\Omega$, NAB BW : 20Hz ~ 20KHz	—	0.9	1.7	μV_{rms}
Input Resistance	R_{IN}	—	—	500	—	K Ω
Ripple Rejection	R.R.	$f_r = 100Hz$, $V_r = 1V_{rms}$	—	55	—	dB
Cross Talk	C.T.	$V_{OUT} = 0dBm$	50	60	—	dB
Forward/Reverse Cross Talk	C.T. (F/R)	$V_{OUT} = 0dBm$	60	70	—	dB

DBL 1045

TYPICAL DC VOLTAGE OF EACH TERMINAL ($V_{CC} = 9V$, $T_a = 25^\circ C$, Dual Mode)

Pin No.	1	2	3	4	5	6	7	8	9	10	11	12	13	14	15	16
Voltage(V)	V_{CC}	3.0	0.7	2.9	2.9	2.9	2.9	GND	2.9	NC	2.9	2.9	2.9	2.9	3.5	2.9

APPLICATION INFORMATION

1. Forward/Reverse Selection Switch

The forward and the reverse selection is controlled by the change of the pin 3 voltage.

Reverse : $0 \sim 0.5V$

Forward : $1.0V \sim V_{CC}$

$I_3 = 12\mu A$ (MAX.)

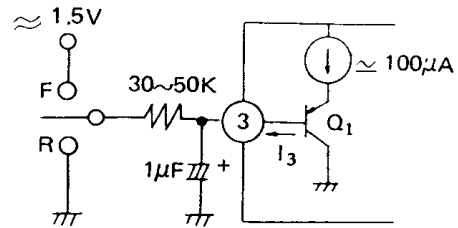

Fig. 1

2. Metal/Normal Selection Switch

The metal and the normal selection is controlled by the change of the pin 15 voltage.

Metal : $3.2V \sim V_{CC}$

Normal : $0 \sim 2.4V$

The emitter Voltage of Q_2 is set by $6V_{BE}$ ($= 3.9V$)

The voltage of pin 15 above $3.2V$ make the Q_2 nonconducting condition.

And then the metal function can be operated.

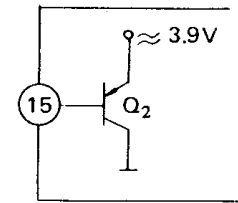
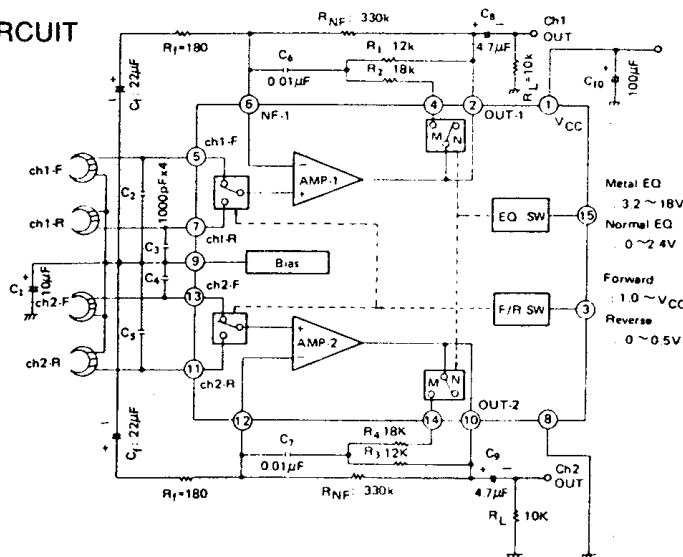

Fig. 2.

3. $C_2/C_3/C_4/C_5$

Capacitor $C_2 \sim C_5$ can prevent an instability caused by the pattern layout or interference of external high frequency signal.

APPLICATION CIRCUIT



Metal EQ : $3.2 \sim 18V$
 Normal EQ : $0 \sim 2.4V$
 Forward : $1.0 \sim V_{CC}$
 Reverse : $0 \sim 0.5V$

DBL 1045

TYPICAL PERFORMANCE CHARACTERISTICS

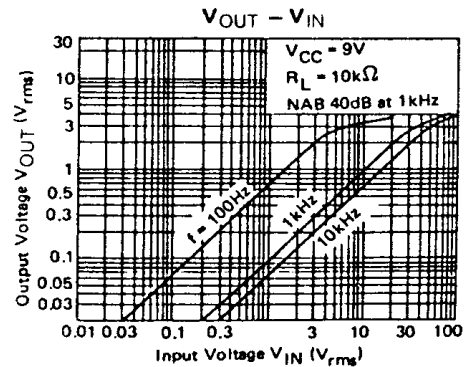
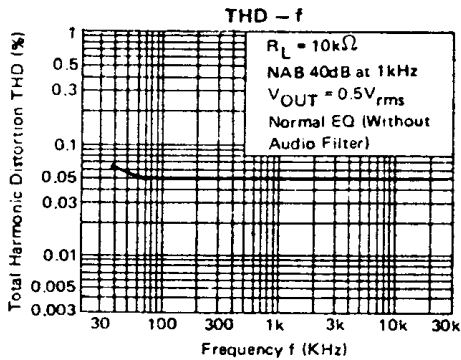
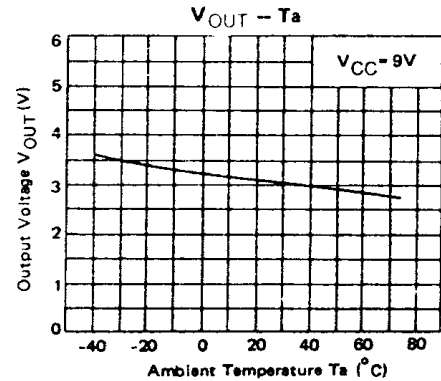
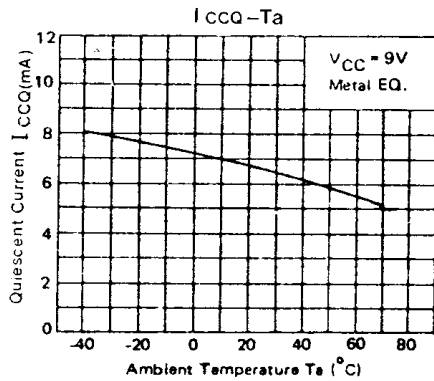
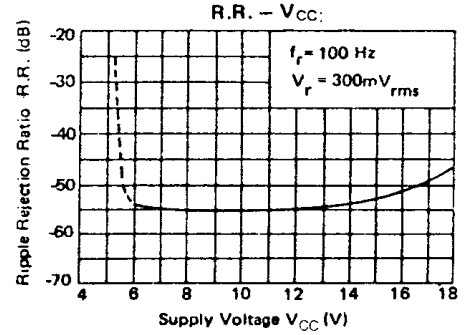
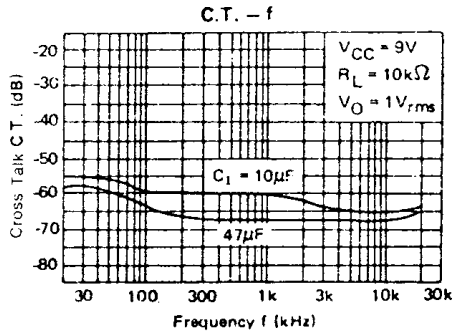
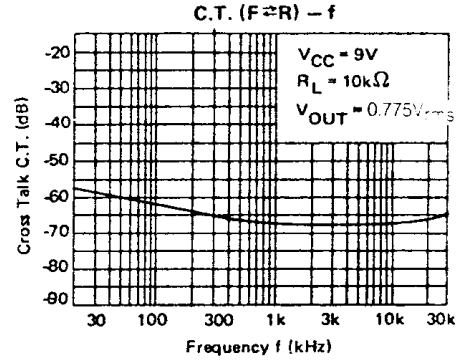
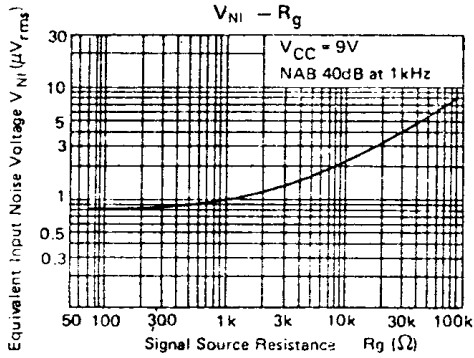

DBL 1045

□ TYPICAL PERFORMANCE CHARACTERISTICS (continued)

