



三合微科技股份有限公司
SAMHOP Microelectronics Corp.

SM5028RF

2¹² RF ENCODER

REV. 1.20

DECEMBER 23, 2004

**The information in this document is subject to change without notice.
© SAMHOP Microelectronics Corp. All Rights Reserved.**

台北縣新店市民權路100號7樓
7F, No. 100, Min-Chyuan Road, Hsintien, Taipei Hsien, Taiwan, R.O.C.
TEL: 886-2-2218-3978/2820 FAX: 886-2-2218-3320
Email : info@samhop.com.tw

**2¹² RF ENCODER****GENERAL DESCRIPTION**

SM5028RF is a RF remote control encoder paired with SM5038RF. It utilizes CMOS technology. The chip has 12 bits of 2-state address pins that provides 2¹² codes. SM5028RF/SM5038RF pair is suitable for use on remote controller.

FEATURES

- * CMOS technology
- * Low power consumption
- * Wide range operating voltage, V_{CC} = 2.4-12V
- * Up to four data bits
- * High noise immunity

APPLICATION

- * Car Security
- * Garage Door
- * Ceiling Fan
- * Home Security/Automatic
- * Toys
- * Wireless doorbell

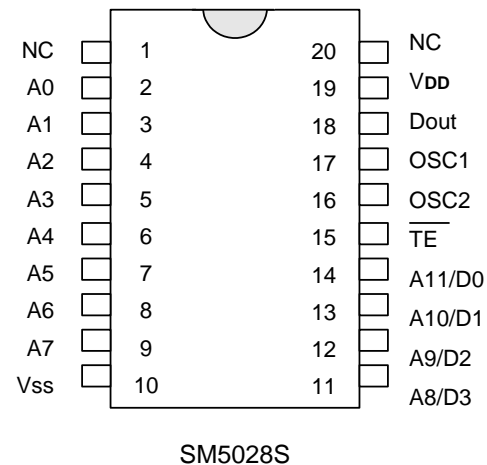
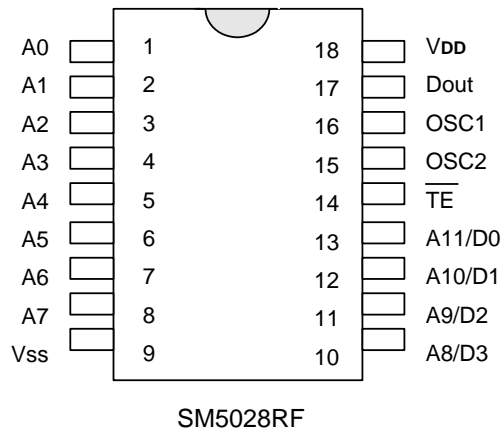
PIN ASSIGNMENTS (TOP VIEW)



2¹² RF ENCODER

BLOCK DIAGRAM

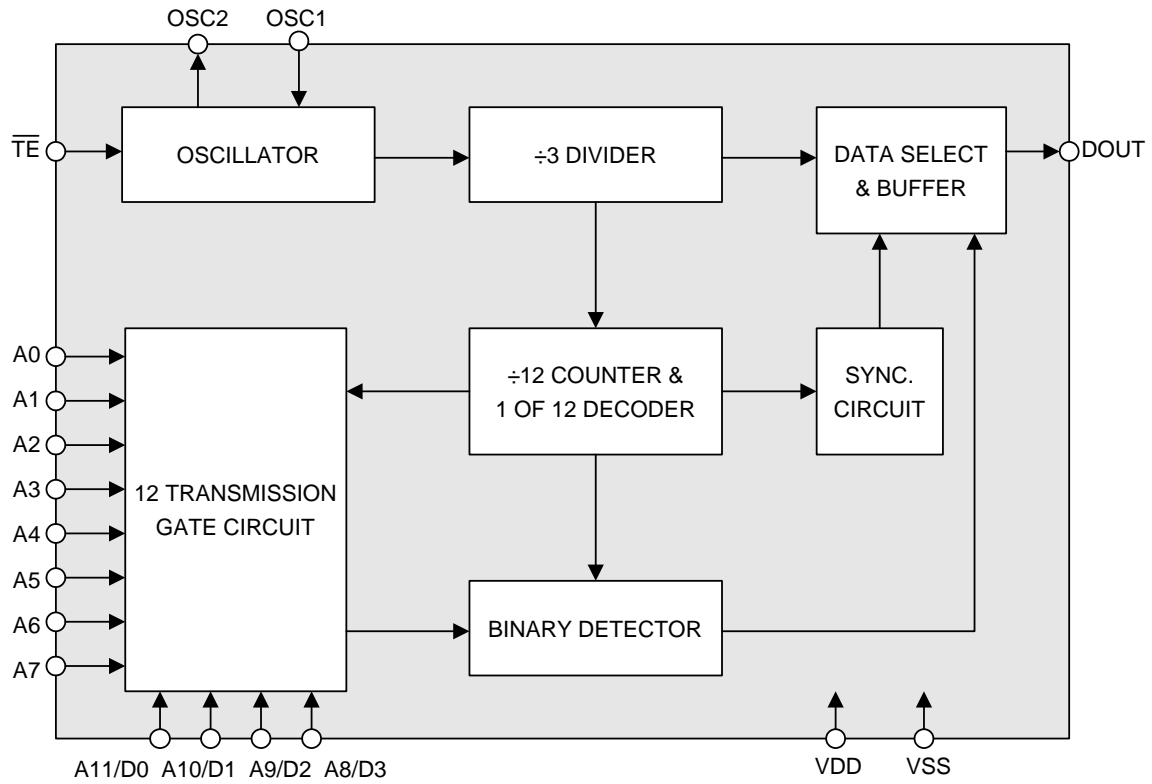

**2¹² RF ENCODER****PIN DESCRIPTION**

NO.	PIN NAME	I / O	FUNCTION
1	A0	I	Address input , each pin can be set to "0" , "1".
2	A1	I	
3	A2	I	
4	A3	I	
5	A4	I	
6	A5	I	
7	A6	I	
8	A7	I	
9	V _{SS}	POWER	Negative power supply.
10	A8/D3	I	Address/data input.
11	A9/D2	I	
12	A10/D1	I	
13	A11/D0	I	
14	$\overline{\text{TE}}$	I	Enables transmission.
15	OSC2	O	Resistor connected between these two pins determine the system clock.
16	OSC1	I	
17	Dout	O	Serial output of encoded signals.
18	V _{DD}	POWER	Positive power supply.



2¹² RF ENCODER

FUNCTION DESCRIPTION

An information word consists of 4 periods as illustrated below.

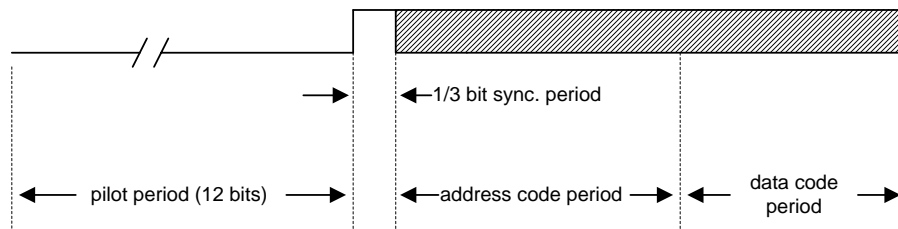

Composition of information

Address/Data waveform

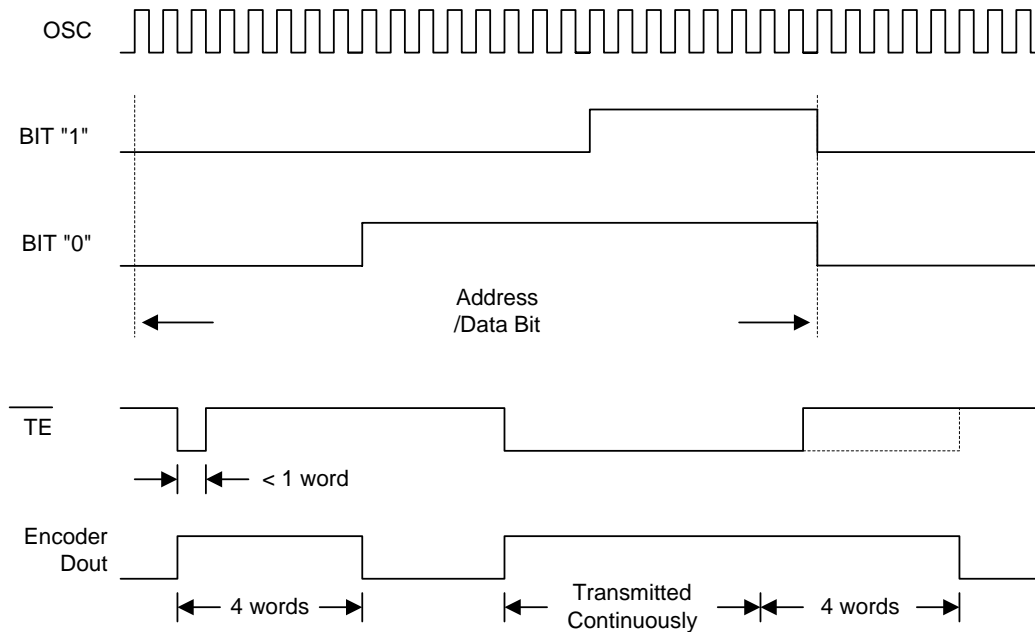

SM5028RF begin a 4-word transmission cycle upon receipt of a transmission enable (TE active low). This cycle will repeat itself as long as the transmission enable (TE is held low). Once the transmission enable returns high the encoder output completes its final cycle and then stops as shown below.



2¹² RF ENCODER

2. OSC Frequency

SM5028RF's oscillator can be constructed by connecting a resistor between OSC1 and OSC2 pin.

Encoder OSC Frequency
KHz

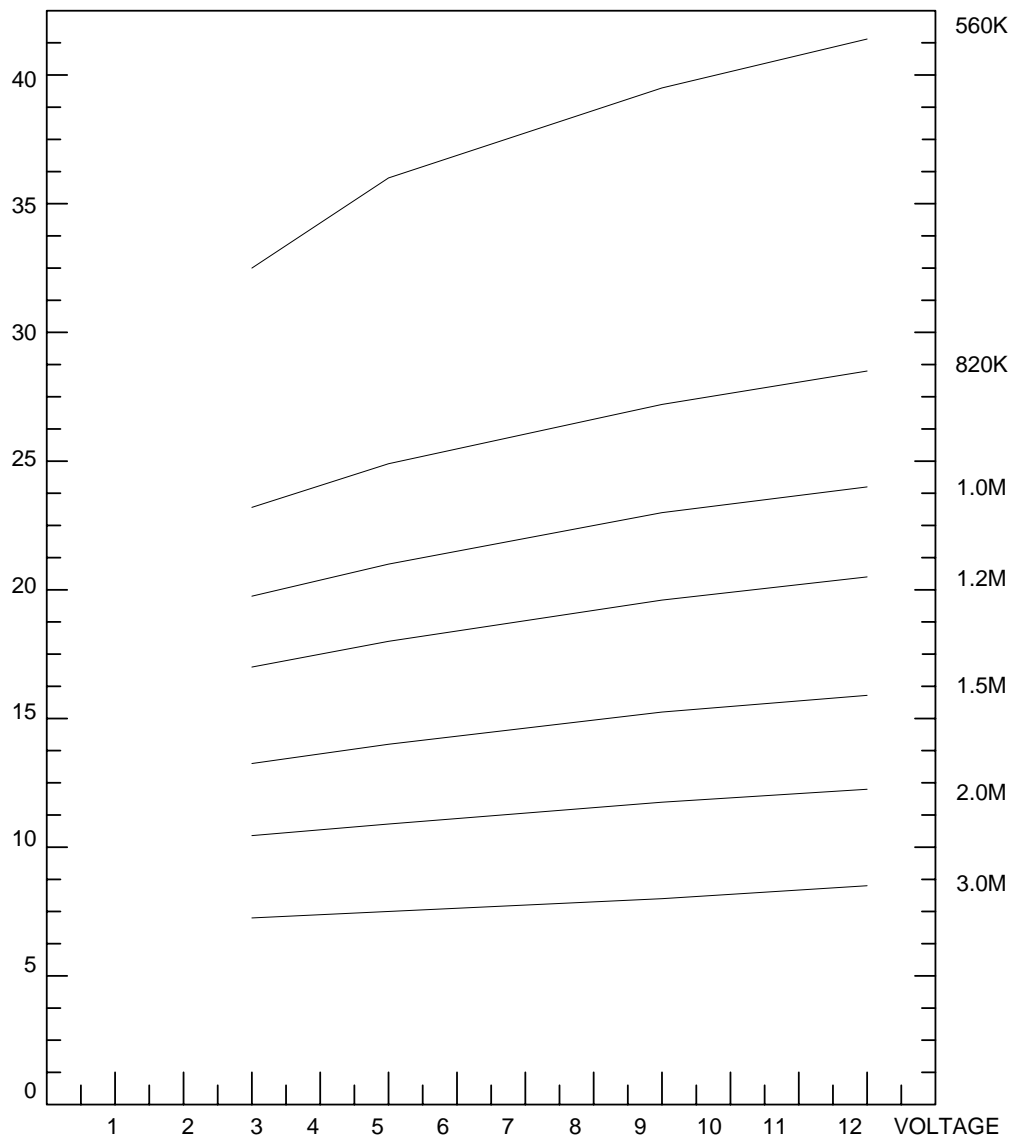

The recommended oscillator frequency is $F_{OSC} \text{ (SM5038RF decoder)} \approx 8 - 10 F_{OSC} \text{ (SM5028RF encoder)}$

**2¹² RF ENCODER****ABSOLUTE MAXIMUM RATINGS**

Parameter	Symbol	Conditions	Ratings	Unit
Supply Voltage	V _{DD} - V _{SS}		-0.3~13	V
Input Voltage	V _I - V _{SS}		V _{SS} -0.3~V _{DD} +0.3	V
Output Voltage	V _O - V _{SS}		V _{SS} -0.3~V _{DD} +0.3	V
Maximum power dissipation	P _a	V _{DD} - V _{SS} = 12V	500	mW
Operating Temperature	T _{opr}		-20~70	°C
Storage Temperature	T _{stg}		-40~125	°C

DC ELECTRICAL CHARACTERISTICS

Parameter	Symbol	Test Condition		Limits			Unit
		V _{DD}	Conditions	Min.	Typ.	Max.	
Operating Voltage	V _{DD}		—	2.4	5	12	V
Operating Current	I _{DD}	3V 12V	No load F _{OSC} = 24KHZ	- -	10 150	20 300	μA
Standby Current	I _{STB}	3V 12V	Oscillator stops	- -	0.1 2	1 4	μA
Output Drive Current	I _{DOUT}	5V	V _{DH} = 0.9V _{DD} (SOURCE) V _{OL} = 0.1V _{DD} (Sink)	-1 1	-1.6 1.6	- -	mA
"H" Input Voltage	V _{IH}	—	—	0.8V _{DD}		V _{DD}	V
"L" Input Voltage	V _{IL}	—	—	0		0.2V _{DD}	V
Oscillator Frequency	F _{OSC}	5V	R _{OSC} = 1M	—	24	—	kHz
\overline{TE} Pull-High Resistance	R \overline{TE}	3V	V \overline{TE} = 0V	—	1.25	—	M
		5V		—	600	—	K
		9V		—	350	—	K
		12V		—	260	—	K
ADDRESS Pull-High Resistance	R _{ADDRESS}	3V		—	680	—	K
		5V		—	340	—	K
		9V		—	180	—	K
		12V		—	140	—	K

(T_a=25⁰C)



2¹² RF ENCODER

APPLICATION CIRCUIT

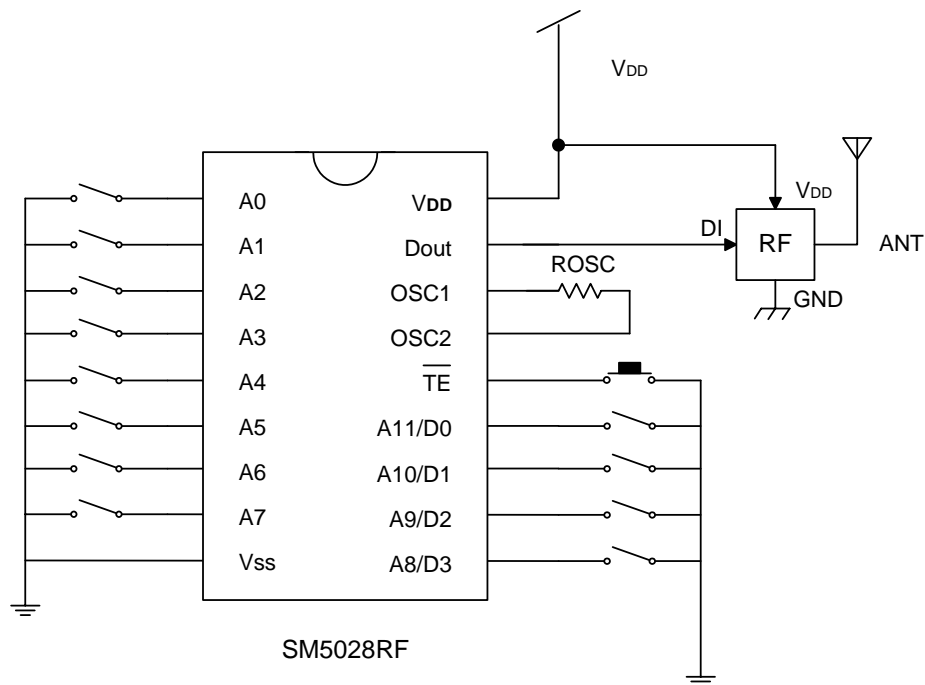



2¹² RF ENCODER

ORDERING INFORMATION

Part NO.	Package
SM5028RF	18Pin DIP

Part NO.	Package
SM5028S	20Pin SOP

