

INTEGRATED VOLTAGE STABILIZER

The TCA530 is an adjustable 30 V integrated circuit voltage stabilizer for use with variable capacitance diodes.

The circuit features: continuous short-circuit protected output, a.f.c. control voltage input, internal switch-on delay (can be adjusted externally), pre-stabilization and crystal temperature control (temperature sensor and heater).

QUICK REFERENCE DATA

Input (supply) voltage range (for $R_i = 3,3 \text{ k}\Omega$)	$V_I = V_P$	50 to 68 V
Output voltage	$V_O = V_{6-16}$	typ. 30 V
Amplitude range of output voltage for a.f.c.	ΔV_{6-16}	typ. $\pm 0,75 \text{ V}$
Variation of output voltage as a function of:		
input (supply) voltage variations	$\Delta V_{6-12}/\Delta V_I$	typ. 0,2 mV/V
output current variations	$\Delta V_{6-12}/\Delta I_6$	typ. 0,5 mV/mA
temperature variations	$\Delta V_{6-12}/\Delta T_{\text{amb}}$	typ. 0,1 mV/K
heater voltage variations	$\Delta V_{6-12}/\Delta V_{1-16}$	typ. 0,2 mV/V
Output current	$I_6 - I_Q$	typ. 3,0 mA

Allowable output voltage range	$V_O = V_{6-16}$	25 to $30 \pm 0,75 \text{ V}$
Allowable output current range	I_6	0 to 4,6 mA

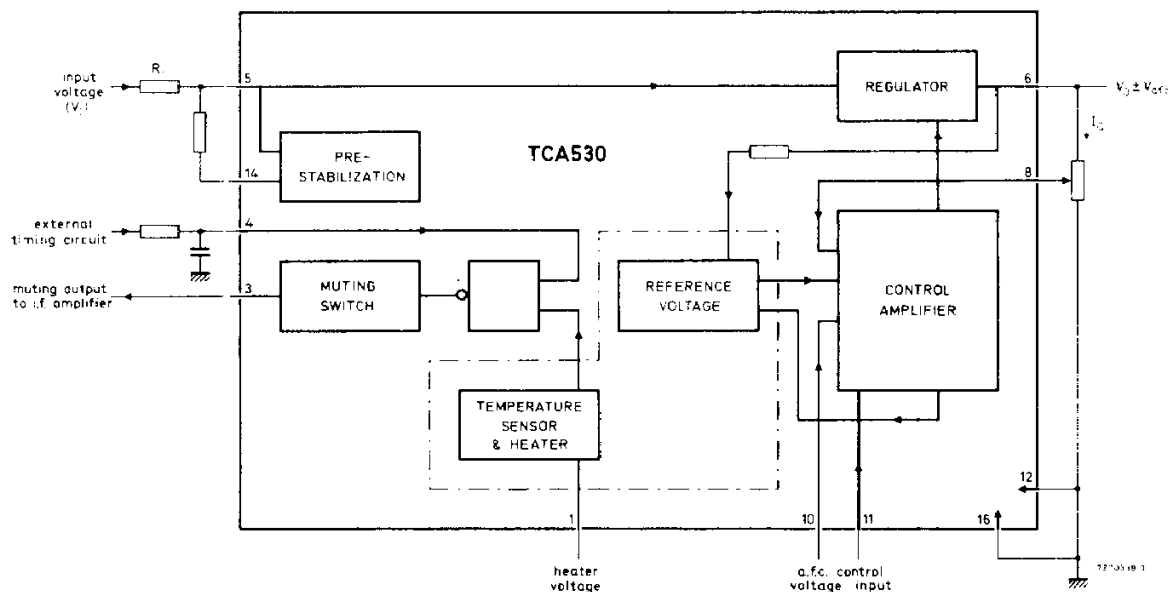

Fig. 1 Block diagram.

PACKAGE OUTLINE

16-lead DIL; plastic (SOT-38).

RATINGS

Limiting values in accordance with the Absolute Maximum System (IEC 134)

Voltages: pin 1 (heater voltage)	V_{1-16}		0 to 20 V
pin 3 (muting switch supply)	V_{3-16}	max.	15 V
pins 10 and 11 (a.f.c. input control voltage)	$\pm V_{10-11}$	max.	6 V
Currents: pin 3	$\pm I_3$	max.	5 mA
pin 4	I_4	max.	500 μ A
pin 5	I_5	max.	25 mA
pin 6	I_6	max.	30 mA
pin 8	I_8	max.	500 μ A
pin 10	I_{10}	max.	500 μ A
pin 11	I_{11}	max.	500 μ A
pin 14	I_{14}	max.	15 mA
Total power dissipation (excluding heater power) at $T_{amb} = 60$ °C	P_{tot}	max.	500 mW
Storage temperature	T_{stg}		-55 to + 150 °C
Operating ambient temperature	T_{amb}		-20 to + 80 °C

CHARACTERISTICS

 $V_{6-12} = 30$ V; $V_{10-12} = V_{11-12} = 10$ V; $V_{1-16} = 15$ V; $T_{amb} = 25$ °C; measured in Fig. 3.

Voltage control

Input (supply) voltage range*

 $R_i = 3,3$ k Ω ; $I_6 = 3,5$ mA $V_I = V_P$ 50 to 68 V

Current consumption

 I_P typ. 8,1 mA
5,2 to 11,0 mA I_5 typ. $I_6 + (1,1 \pm 0,3)$ mA

Regulator voltage drop

within operating range of
the pre-stabilizer V_{5-6} typ. 2,7 V
2 to 3,5 Voutside operating range of
the pre-stabilizer** $V_{5-6} <$ 6 V

Output current (start of current limiting)

 $I_6 >$ 8 mA

Internal reference voltage

 V_{8-12} typ. 20 V
18,2 to 21,8 V* For other input (supply) voltage ranges and output currents, the series resistor R_i has to be altered (see also Fig. 2).

** The specified output voltage dependency of the input (supply) voltage is not guaranteed outside the operating range of the pre-stabilizer.

Input current of control amplifier	I_8	typ. <	0,5 μ A 1 μ A
Variation of output voltage as a function of *			
input (supply) voltage variations	$\Delta V_{6-12}/\Delta V_1$	typ.	0,2 mV/V
output current variations	$\Delta V_{6-12}/\Delta I_6$	typ.	0,5 mV/mA
temperature variations	$\Delta V_{6-12}/\Delta T_{amb}$	typ.	0,1 mV/K
heater voltage variations	$\Delta V_{6-12}/\Delta V_{1-16}$	typ.	0,2 mV/V
Hum suppression at f = 50 Hz			
between input (supply) voltage and pin 6		typ.	80 dB
between pins 5 and 6		typ.	60 dB
between pins 1 and 6		typ.	80 dB
Output noise voltage at f = 10 Hz to 15 kHz (r.m.s. value)	$V_{n(rms)}$	<	50 μ V

A.F.C. control amplifier

Common mode input voltage range	$V_{10-12} = V_{11-12}$		6,0 to 18,0 V
Common mode rejection ratio	CMRR	typ.	60 dB
Input current	$I_{10} = I_{11}$	typ. <	0,1 μ A 0,5 μ A
Input resistance	$R_{i(10-11)}$	>	1 M Ω
Ratio between output voltage variation and a.f.c. input voltage variation	$\Delta V_{6-12}/\Delta V_{10-11}$		1,2 : 1
Amplitude range of output voltage	ΔV_{6-12}	typ.	$\pm 0,75$ V $\pm 0,5$ to $\pm 1,0$ V

Muting switch

When the crystal temperature has reached approximately its stationary final value, the output of the muting switch (pin 3) becomes high-ohmic. The switching of pin 3 can be delayed by an external RC-circuit at pin 4 or by a switching voltage.

Muting switch ON (pin 3 low-ohmic)

Input voltage	V_{4-16}	<	8 V
Input current	I_4	typ.	1 μ A
Output saturation voltage at $I_3 = 1$ mA	$V_{3-16 sat}$	typ. <	0,45 V 0,6 V

Muting switch OFF (pin 3 high-ohmic)

Input voltage	V_{4-16}		8 to 11 V
Input current	I_4	>	0,1 μ A
Output voltage	V_{3-16}	<	15 V
Output current	I_3	<	1 μ A
Internal switch-on delay	t_d	<	3 s

* External component value changes are not taken into account.

100-900-33-000-001
 100-900-33-000-001
 100-900-33-000-001



CHARACTERISTICS (continued)

Crystal temperature control

Heater voltage range	V_{1-16}	8 to 20 V
Heater peak current at switching on	I_{1M}	typ. 230 mA < 300 mA
Continuous heater current at $V_{1-16} = 15$ V	I_1	typ. 40 mA < 55 mA
Continuous heater power	P_h	typ. 600 mW

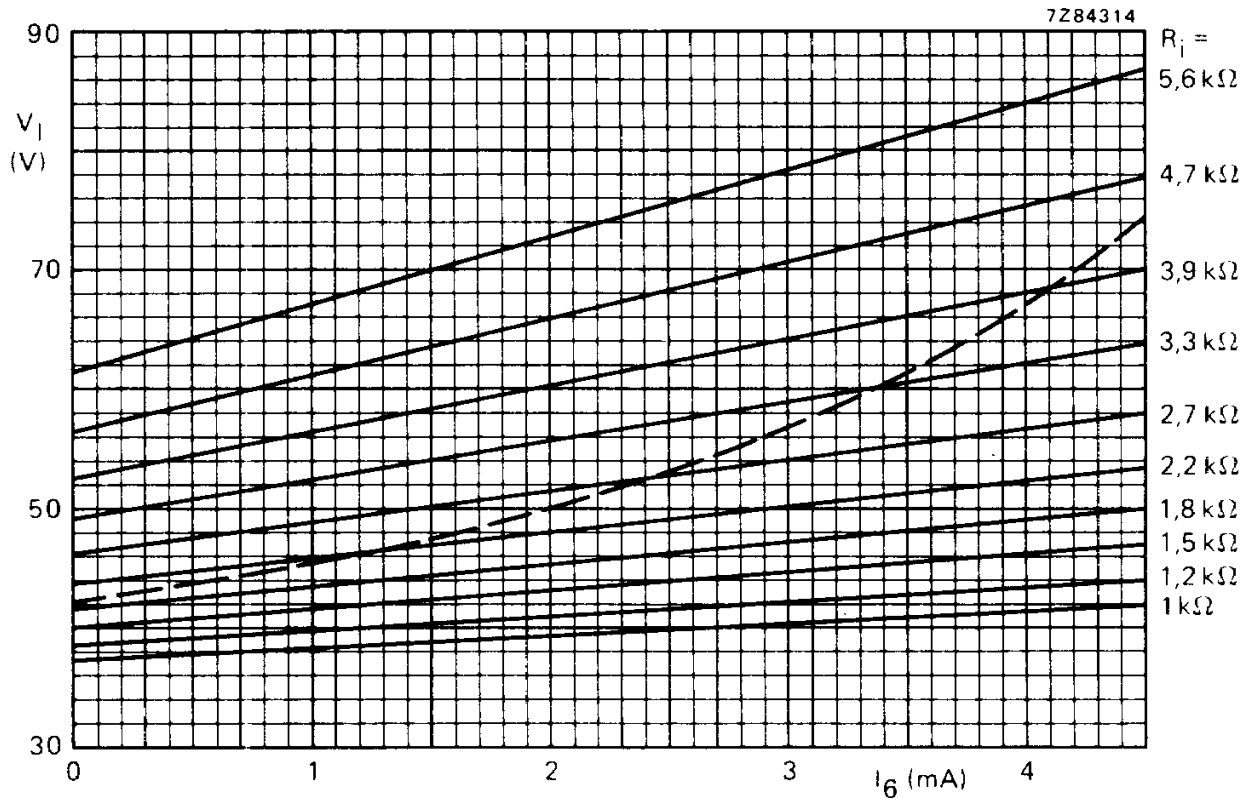

Fig. 2 Curves to obtain R_i -values for various input (supply) voltages and/or output currents. Conditions: $V_{6-12} = 30$ V; tolerance of $I_6 = \pm 20\%$; $R_{5-14} = 3,6$ k Ω ; tolerance of $R_i = \pm 2\%$. Above the dotted curve a tolerance of V_1 (Vp) of $\pm 15\%$ is allowed.

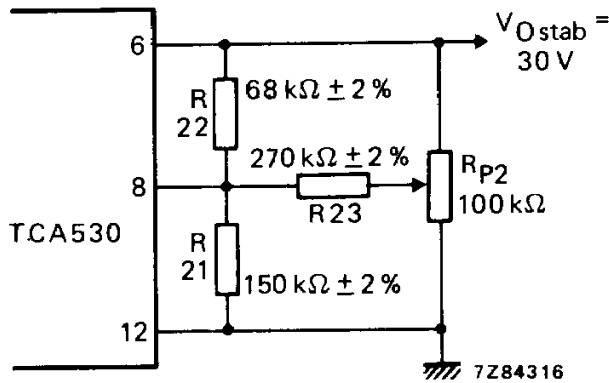

Fig. 4 Voltage divider for the narrowest possible temperature dependency.

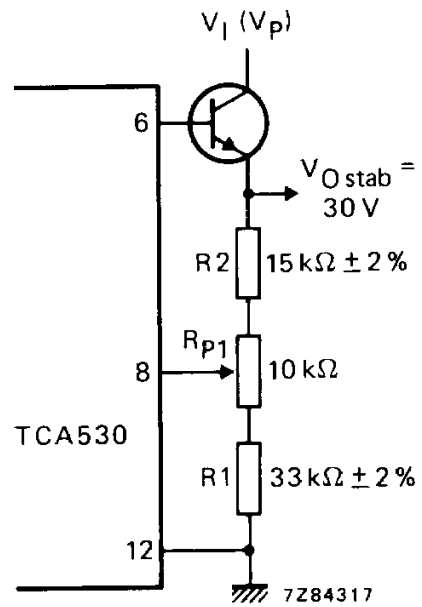

Fig. 5 Circuit extension by means of a series transistor at the output, for output currents > 4,6 mA.

The following table gives some resistor value examples for various output voltages with $\Delta R/R \leq \pm 2\%$ and $\Delta R_p/R_p \leq \pm 20\%$.

V_{Ostab} V	R_{p2} kΩ	R_{21} kΩ	R_{22} kΩ	R_{23} kΩ	R_{p1} kΩ	R_1 kΩ	R_2 kΩ
30	100	200	82	300	10	20	10
30	47	180	82	300	47	100	47
29					22	39	18
28 ⁺	100	220	75	300	22	39	15
28	47	300	100	430			
27					47	68	24
26					22	27	8,2
25	100	560	91	390	47	47	12
25	47	620	100	430			

The series resistors R_i and R_i' (see Fig. 3), as well as the input (supply) voltage $V_I (V_p)$, have to be adapted to the chosen output voltages V_{Ostab} .

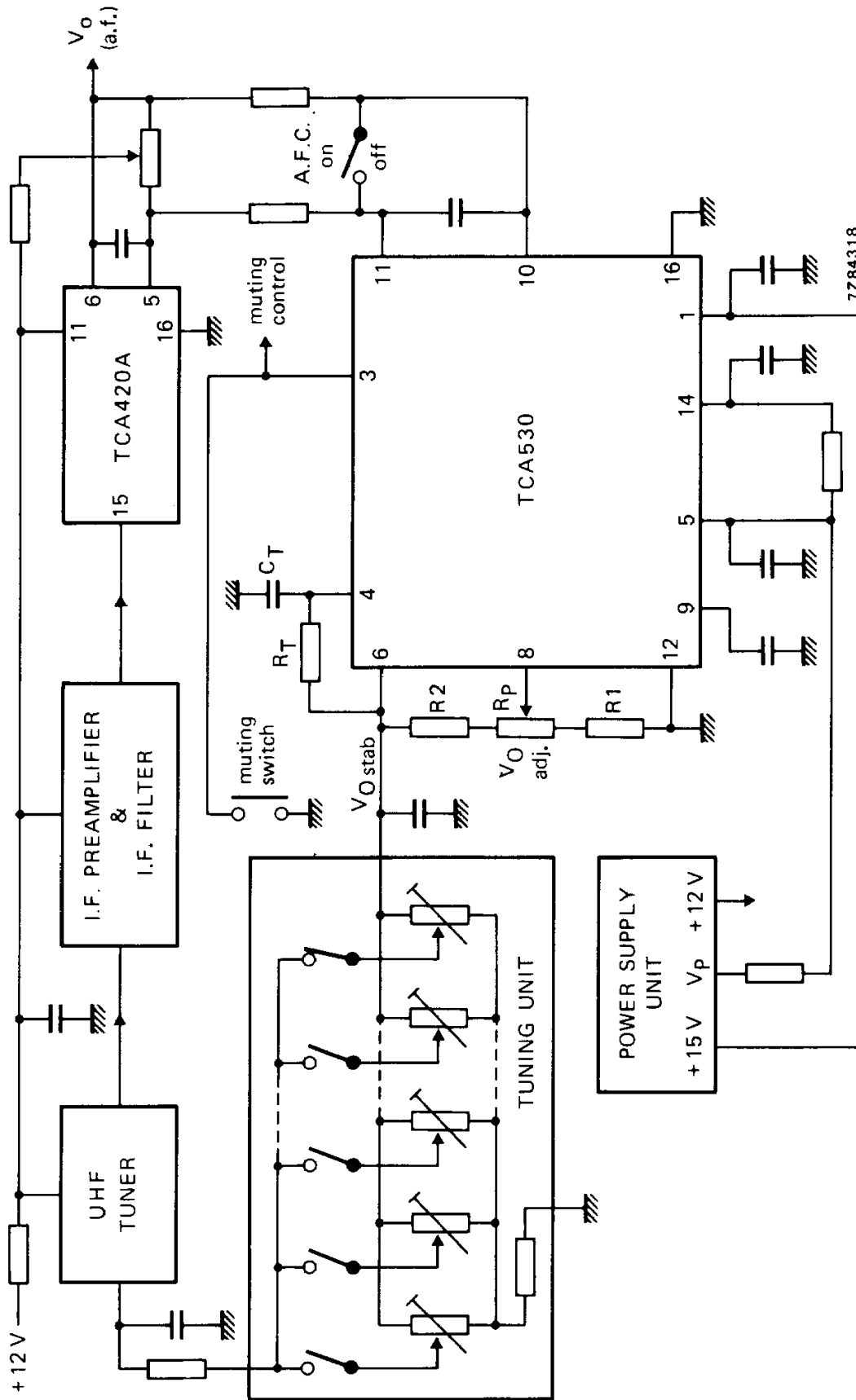

Fig. 6 Application example; f.m. receiver with TCA530 and TCA420A.



Doc. 990. 33 000. 001.