



DC COMPONENTS CO., LTD.
RECTIFIER SPECIALISTS

MP6005
THRU
MP610

TECHNICAL SPECIFICATIONS OF SINGLE-PHASE SILICON BRIDGE RECTIFIER
VOLTAGE RANGE - 50 to 1000 Volts
CURRENT - 6.0 Amperes

FEATURES

- * Surge overload rating: 125 Amperes peak
- * Low forward voltage drop
- * Small size: simple installation

MECHANICAL DATA

- * Case: Molded plastic with heatsink
- * Epoxy: UL 94V-0 rate flame retardant
- * Lead: MIL-STD-202E, Method 208 guaranteed
- * Polarity: Symbols molded or marked on body
- * Mounting position: Any
- * Weight: 6.1 grams

MAXIMUM RATINGS AND ELECTRICAL CHARACTERISTICS

Ratings at 25°C ambient temperature unless otherwise specified.
Single phase, half wave, 60Hz, resistive or inductive load.
For capacitive load, derate current by 20%.

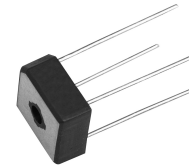

MP-6

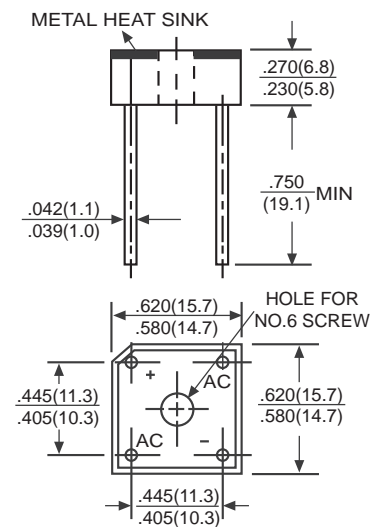

Dimensions in inches and (millimeters)

	SYMBOL	MP6005	MP601	MP602	MP604	MP606	MP608	MP610	UNITS
Maximum Recurrent Peak Reverse Voltage	V _{RRM}	50	100	200	400	600	800	1000	Volts
Maximum RMS Bridge Input Voltage	V _{RMS}	35	70	140	280	420	560	700	Volts
Maximum DC Blocking Voltage	V _{DC}	50	100	200	400	600	800	1000	Volts
Maximum Average Forward Output Current at T _c = 75°C	I _O	6.0							Amps
Peak Forward Surge Current 8.3 ms single half sine-wave superimposed on rated load (JEDEC Method)	I _{FSM}	125							Amps
Maximum Forward Voltage Drop per element at 3.0A DC	V _F	1.0							Volts
Maximum DC Reverse Current at Rated DC Blocking Voltage per element	@ T _A = 25°C	10							μAmps
	@ T _c = 100°C	500							
Operating Temperature Range	T _J	-55 to +125							°C
Storage Temperature Range	T _{STG}	-55 to +150							°C

RATING AND CHARACTERISTIC CURVES (MP6005 THRU MP610)

FIG. 1 - MAXIMUM NON-REPETITIVE FORWARD SURGE CURRENT

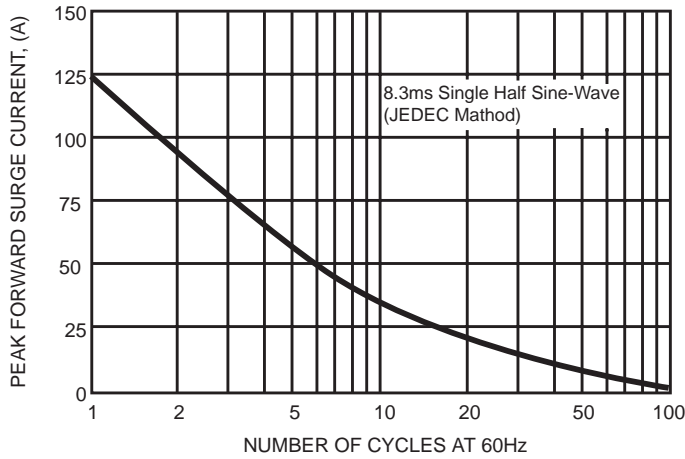

FIG. 2 - TYPICAL FORWARD CURRENT DERATING CURVE

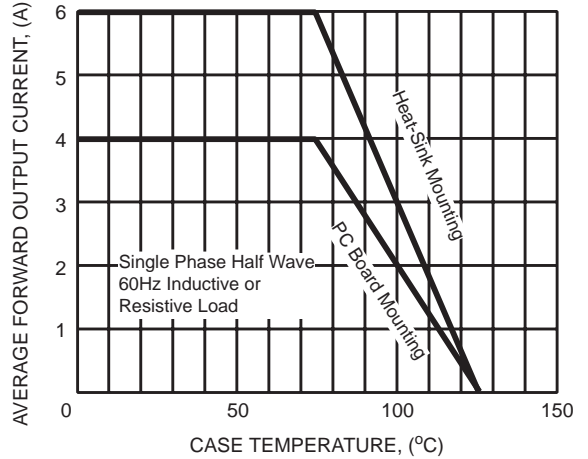

FIG. 3 - TYPICAL INSTANTANEOUS FORWARD CHARACTERISTICS

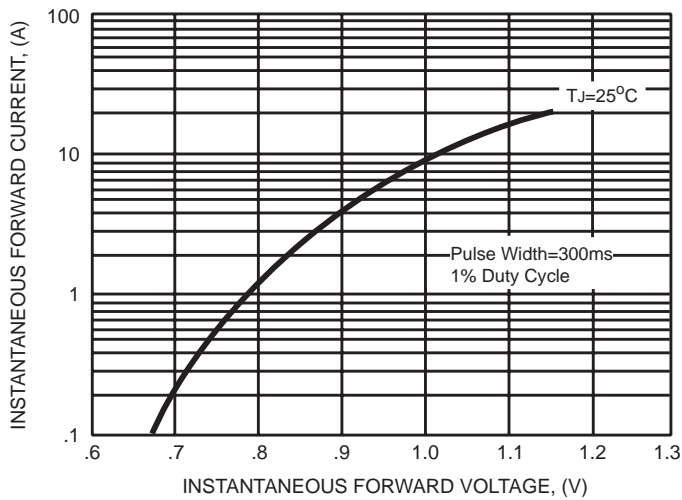
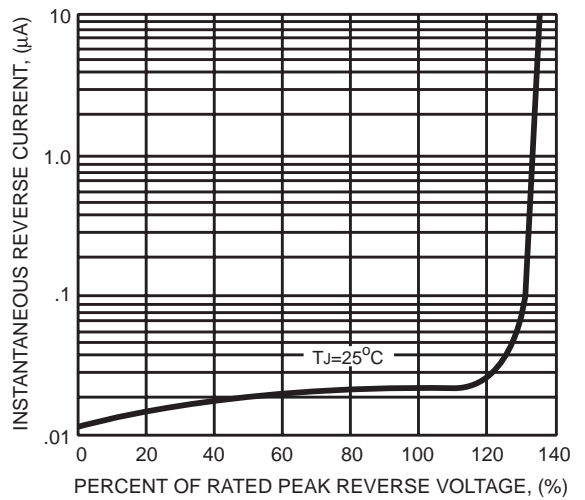

FIG. 4 - TYPICAL REVERSE CHARACTERISTICS



DC COMPONENTS CO., LTD.