

MAS9181B/C

OCTAL 8-BIT TRIMMER IC

- Eight discrete DACs
- I²C-bus slave receiver
- Voltage output

DESCRIPTION

The MAS9181 comprises eight digital to analog converters (DACs) each controlled by a two-wire I²C bus. The DACs are individually programmed using an 8-bit word to select an output from one of 256 voltage steps. The maximum output voltage of all DACs is set

by V_{max} and the resolution is V_{max}/256. At power-on all outputs are set to their lowest value. The I²C-bus slave receiver has 3 programmable address pins (2 for MAS9181 CS).

FEATURES

- Rail to rail output stages
- Octal 8-bit DACs on a single monolithic chip
- Power supply range from +5 V to +12 V
- -20°C to +85°C temperature range
- 16-pin PDIL and SO package
- Power-up reset

APPLICATION

- Trimmer replacement
- AGC/AFT or TVs and VCRs
- Graphic equalizers
- High resolution monitors

BLOCK DIAGRAM

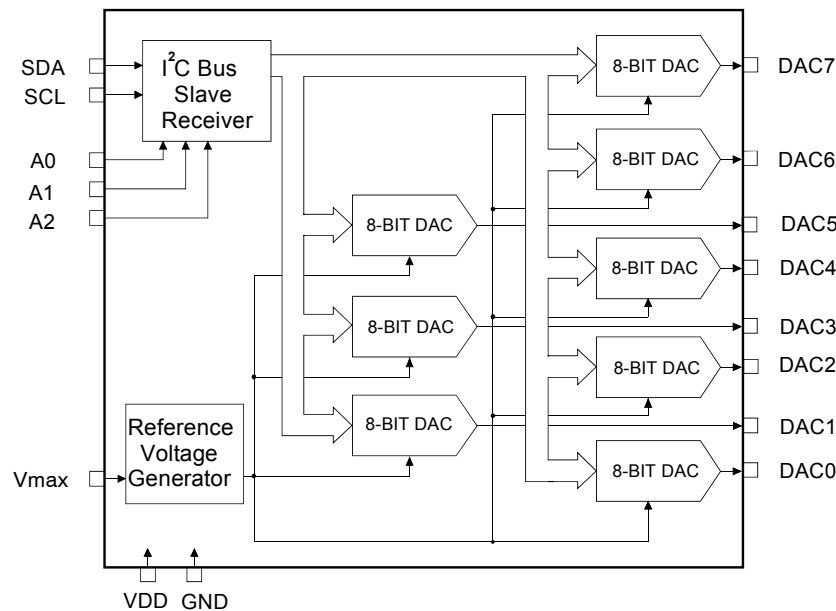

PIN CONFIGURATION

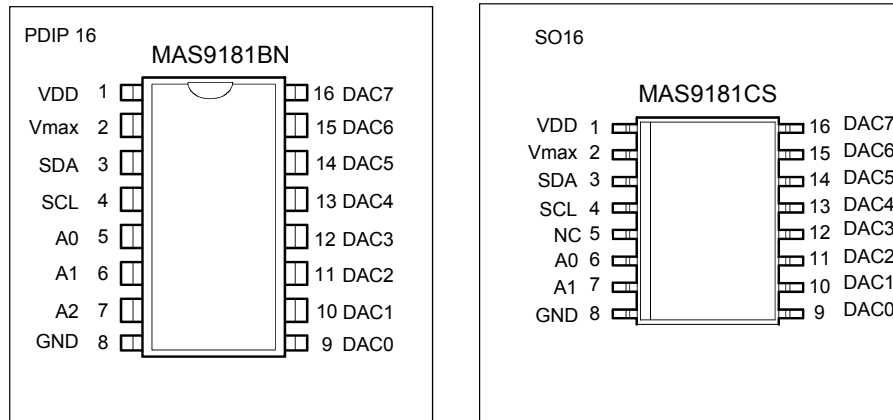

PIN DESCRIPTION

Pin name	Pin no.		I/O	Function
	*1	*2		
VDD	1	1	P	Positive supply voltage
Vmax	2	2	I	Control input for DAC maximum output voltage
SDA	3	3	I/O	I ² C bus serial data input/output
SCL	4	4	I	I ² C bus serial data clock
A ₀	5	6	I	Programmable address bits for I ² C bus slave receiver
A ₁	6	7	I	Programmable address bits for I ² C bus slave receiver
A ₂	7	NC	I	Programmable address bits for I ² C bus slave receiver
GND	8	8	G	Ground
DAC0	9	9	O	Analog voltage output
DAC1	10	10	O	Analog voltage output
DAC2	11	11	O	Analog voltage output
DAC3	12	12	O	Analog voltage output
DAC4	13	13	O	Analog voltage output
DAC5	14	14	O	Analog voltage output
DAC6	15	15	O	Analog voltage output
DAC7	16	16	O	Analog voltage output

*1 MAS9181BN (PDIP16)

*2 MAS9181CS (SO16)

ABSOLUTE MAXIMUM RATINGS

(conditions)

Parameter	Symbol	Conditions	Min	Max	Unit
Supply Voltage	VDD		-0.5	18	V
Supply current	IDD		-10	40	mA
I ² C-bus line voltage	V(3),V(4)		-0.5	5.9	V
Input voltage	V _{in}		-0.5	VDD+0.5	V
Output voltage	V _o		-0.5	VDD+0.5	V
Maximum current on any pin	I _{max}			10	mA
total power dissipation	P _{tot}			500	mW
Operating ambient temperature range	T _{amb}		-20	+85	°C
Storage temperature range	T _{stg}		-65	+150	°C

RECOMMEDED OPERATION CONDITIONS

 (All voltages are with respect to GND; T_{amb} = +25 °C; VDD = 12V unless otherwise specified)

Parameter	Symbol	Conditions	Min	Typ	Max	Unit
Supply Voltage	VDD		4.5	12	13.2	V
Supply current	IDD	No loads, V _{max} =VDD=12V, All data=00 _{OCT}		3.0	5.0	mA
Total power dissipation	P _{tot}	No loads, V _{max} =VDD=12V, All data=00 _{OCT}		40	60	mW

ELECTRICAL CHARACTERISTICS

◆ Inputs

SDA, SCL input (pins 3, 4)

 (All voltages are with respect to GND; T_{amb} = -20 °C to 85 °C; VDD = 5V to 12V unless otherwise specified)

Parameter	Symbol	Conditions	Min	Typ	Max	Unit
Input voltage range	V _I		-0.5		5.5	V
Input low voltage	V _{IL}				1.0	V
Input high voltage	V _{IH}		3.0			V
Input leakage current	I _{IL}	V _{in} = 0V or VDD	-1		+1	μA
Power-up reset				3.5		V

ELECTRICAL CHARACTERISTICS
Address Input (pins 5, 6, 7)

(All voltages are with respect to GND; Tamb = -20 °C to 85 °C; VDD = 5V to 12V unless otherwise specified)

Parameter	Symbol	Conditions	Min	Typ	Max	Unit
Input voltage range	V_I		0		VDD	V
Input low voltage	V_{IL}				1.0	V
Input high voltage	V_{IH}		3.0			V
Input current low	I_{IL}			-10	-15	μ A
Input current high	I_{IH}				1	μ A

Vmax Control Input for DAC maximum output voltage (pin 2)

(All voltages are with respect to GND; Tamb = -20 °C to 85 °C; VDD = 5V to 12V unless otherwise specified)

Parameter	Symbol	Conditions	Min	Typ	Max	Unit
Pin 2 current	I_2			7	10	μ A

◆ Outputs

(All voltages are with respect to GND; Tamb = -20 °C to 85 °C; VDD = 5V to 12V unless otherwise specified)

Parameter	Symbol	Conditions	Min	Typ	Max	Unit
DAC output (pin 9 to 16) Output voltage range	V_o	$I_o = \pm 100 \mu$ A	0.1		VDD-0.1	V
		$I_o = \pm 500 \mu$ A	0.2		VDD-0.2	V
Output impedance	Z_o	data = 7F		30		Ω
DAC output drive range	I_o	Upper side saturation voltage= 0.2v Low side saturation voltage = 0.2v	-1		1	mA
Output capacitive load	C_o				2	nF

SDA Output (pin 3)

(All voltages are with respect to GND; Tamb = -20 °C to 85 °C; VDD = 5V to 12V unless otherwise specified)

Parameter	Symbol	Conditions	Min	Typ	Max	Unit
Output voltage low	V_{OL}	$I_3 = 3.0$ mA			0.4	V

Linearity

(All voltages are with respect to GND; Tamb = -20 °C to 85 °C; VDD = 5V to 12V unless otherwise specified)

Parameter	Symbol	Conditions	Min	Typ	Max	Unit
Differential nonlinearity	DNL	$I_o = 0$ (without load) $V_{max} = VDD-1.0$	-1		1	LSB
Integral nonlinearity	INL	$I_o = 0$ (without load) $V_{max} = VDD-1.0$	-1.5		1.5	LSB
Zero code error ¹	ZCE	data = 00		10	30	mV
Power supply rejection ¹	PSRR				5	mV/V
Zero code temperature coefficient ¹	TC _o		-200		200	μ V/°C

Note 1: Guaranteed by design but not production tested

FUNCTIONS

◆ I²C - bus

The MAS9181 I²C-bus interface is a receiver- only slave. Data is accepted from the I²C - bus in the following format.

S	0 1 0 0 A2 A1 A0 0	A	I3 I2 I1 I0 SD SC SB	A	D7 D6 D5 D4 D3 D2 D1	A	P
	Address byte		Instruction byte		First data byte		
			SA		D0		

S	Start condition	A2, A1, A0	programmable address bits
P	Stop condition	I3, I2, I1, I0	instruction bits
A	Acknowledgement	SD, SC, SB, SA	sub-address bits
		D7, D6, D5, D4, D3, D2, D1, D0	data bits

◆ I²C - bus timing

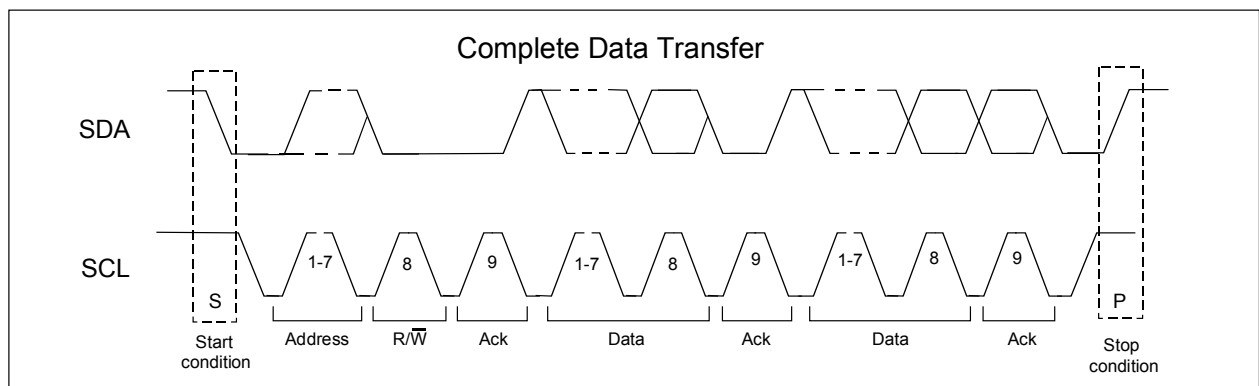
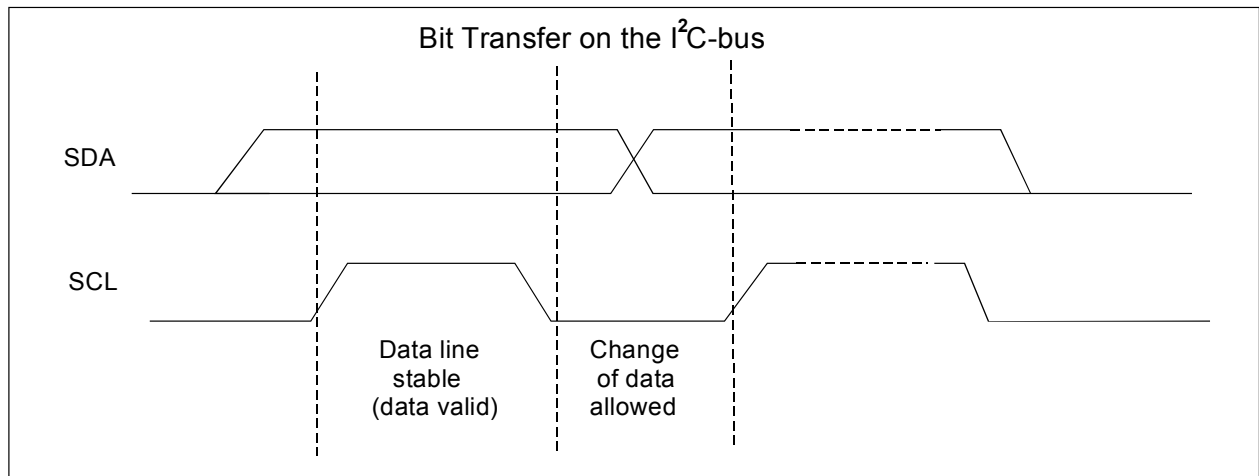

FUNCTIONS

◆ Address Byte

Valid addresses are 40, 42, 44, 46, 48, 4A, 4C, 4E(hex), depending on the programming of bits A2, A1 and A0. With these addresses, up to eight MAS9181 ICs can be operated independently from one I²C-bus. No other addresses are acknowledged by the MAS9181. The

address inputs A0, A1 and A2 are programmed by connection to GND for An = 0 or to VDD for An = 1. If the inputs are left floating, An = 1 will result. For MAS9181CS, A2 is always 1.

◆ Instruction and data bytes

Valid instructions from 00 to 0F and F0 to FF (hex); MAS9181 will not respond to other instruction value, but will still generate an acknowledgement. Instructions 00 to 0F cause auto-incrementing of the sub-address (bits SD to SA) when more than one data byte is sent within one transmission. With auto-incrementing, the first data byte is written into the DAC addressed by bits SD to SA and then the sub-address is automatically incremented by one position for the next databyte in the series. Auto-

incrementing does not occur with instructions F0 to FF. The DAC addressed by the sub-address will always receive the data if more than one data byte is sent. Valid sub-addresses (bits SD to SA) are 0 to 7 (hex) relating numerically to DAC0 to DAC7. When the auto-incrementing function is used, the sub-address will sequence through all possible values (0 to F, 0 to F, etc.). While the sub-address is between 8 and F no DAC outputs change.

◆ I²C - bus

Input SCL (pin 4) and input/output SDA (pin 3) conform to I²C-bus specifications. Pins 3 and 4 are protected against voltage pulses by internal zener diodes

connected to the ground plane and therefore the normal bus line voltage shall not exceed 5.5V.

◆ Input Vmax

Input Vmax (pin 2) provides a means of comprising the output voltage swing of the DACs. The maximum DAC output voltage is restricted to approximately Vmax while

the 8-bit resolution is maintained, therefore giving a finer voltage resolution of smaller output swings.

APPLICATION INFORMATION

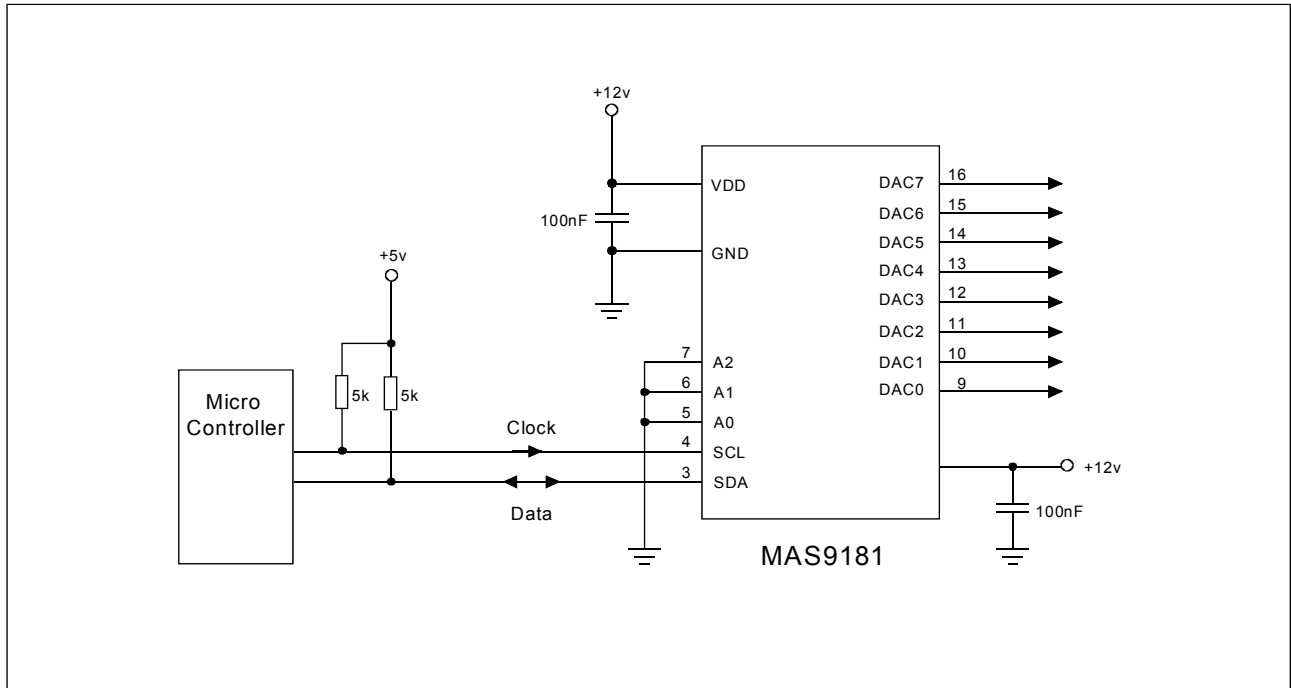

PACKAGE OUTLINES

16 LEAD PDIP OUTLINE (300 MIL BODY)

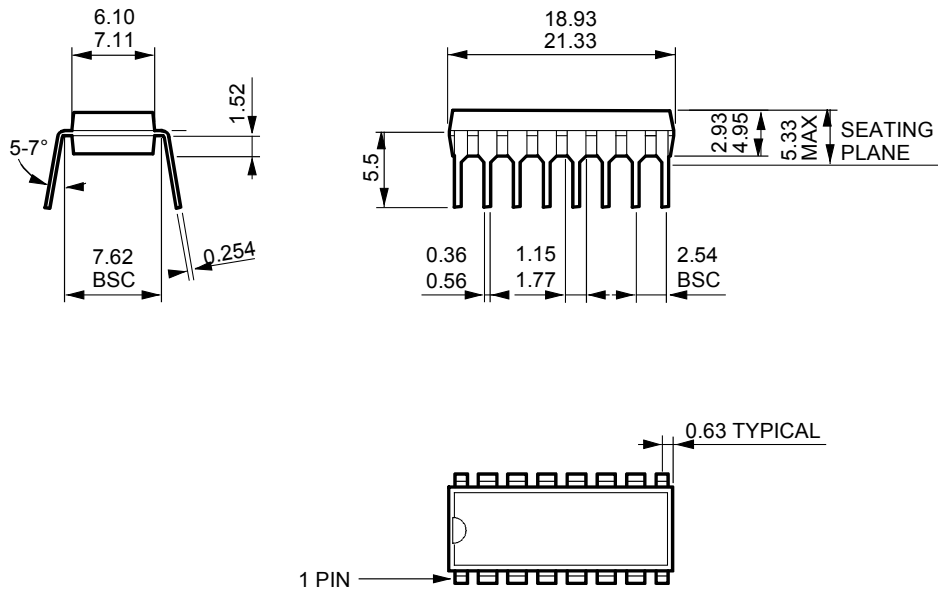

16 LEAD SO OUTLINE (300 MIL BODY)

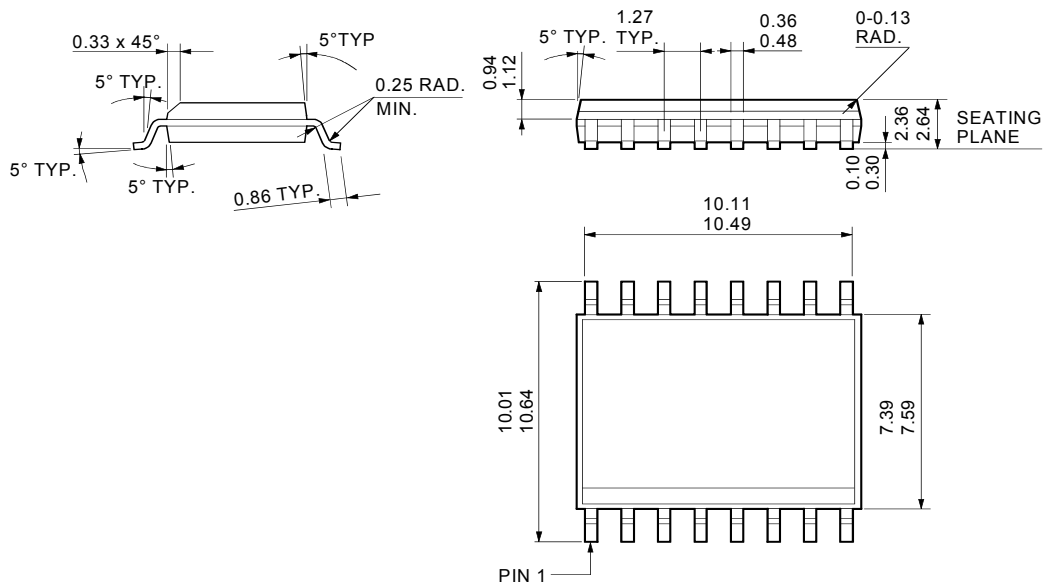

ALL MEASUREMENTS IN mm

ORDERING INFORMATION

Product Code	Product	Package	Comments
MAS9181BN	OCTAL 8-BIT TRIMMER-IC	16 Pin PDIP 0.3"	
MAS9181CS	OCTAL 8-BIT TRIMMER-IC	16 Pin SO 0.3"	2 Address Pins

LOCAL DISTRIBUTOR

--

MICRO ANALOG SYSTEMS OY CONTACTS

Micro Analog Systems Oy Kamreerintie 2, P.O. Box 51 FIN-02771 Espoo, FINLAND	Tel. +358 9 80 521 Fax +358 9 805 3213 http://www.mas-oy.com
--	--

NOTICE

Micro Analog Systems Oy reserves the right to make changes to the products contained in this data sheet in order to improve the design or performance and to supply the best possible products. Micro Analog Systems Oy assumes no responsibility for the use of any circuits shown in this data sheet, conveys no license under any patent or other rights unless otherwise specified in this data sheet, and makes no claim that circuits are free from patent infringement. Applications for any devices shown in this data sheet are for illustration only and Micro Analog Systems Oy makes no claim or warranty that such applications will be suitable for the use specified without further testing or modification.