

## DESCRIPTION

The MP1543 is a highly efficient, synchronous, fixed frequency, current-mode step-up converter with output to input disconnect, inrush current limiting and internal soft-start. It includes an error amplifier, ramp generator, comparator, N-Channel switch and P-Channel synchronous rectified switch (which greatly improves efficiency). The output disconnect feature allows the output to be completely isolated from the input in shutdown mode.

The 500KHz switching frequency allows for smaller external components producing a compact solution for a wide range of load currents. The internal compensation and soft-start minimizes the external component count and limits the inrush current during startup. The MP1543 regulates the output voltage up to 6V and provides up to 400mA from a 2-cell AA with a 3.3V output.

The MP1543 is offered in a thin SOT23-5 package.

## EVALUATION BOARD REFERENCE

Board Number	Dimensions
EV1543DJ-01A	2.4"X x 2.4"Y x 0.4"Z

## FEATURES

- Over 90% Efficiency
- Output to Input Disconnect at Shutdown Mode
- Internal Synchronous Rectifier
- Inrush Current Limiting and Internal Soft-Start
- Internal Compensation
- 1.5A Typical Switch Current Limit
- 500KHz Fixed Switching Frequency
- Zero Current Shutdown Mode
- Thermal Shutdown
- 5-Pin TSOT-23 Package

## APPLICATIONS

- MP3 Players
- Handheld Computers and PDAs
- Digital Still and Video Cameras
- External Modems
- Small LCD Displays

"MPS" and "The Future of Analog IC Technology" are Trademarks of Monolithic Power Systems, Inc.

## TYPICAL APPLICATION

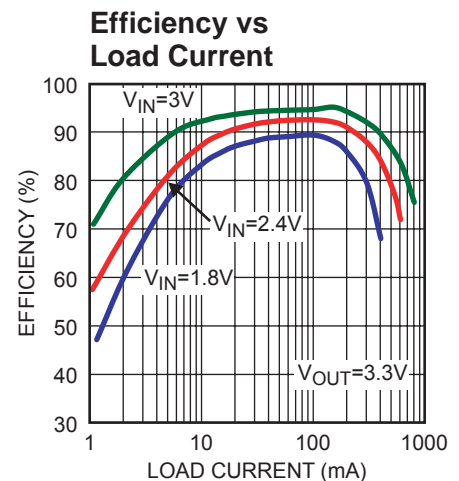
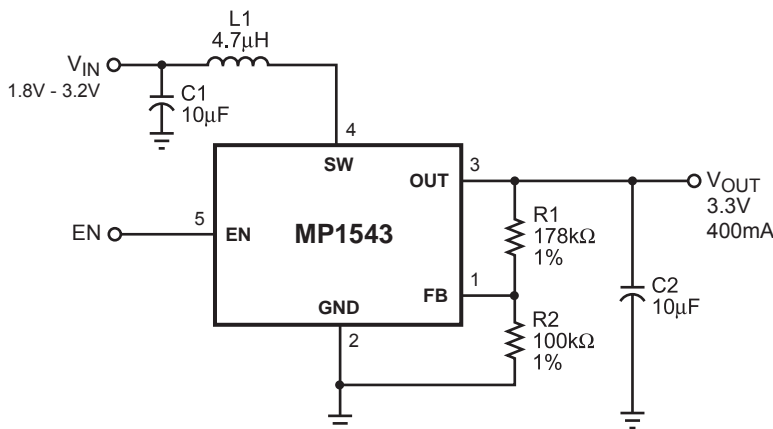

MP1543-EC01

### PACKAGE REFERENCE

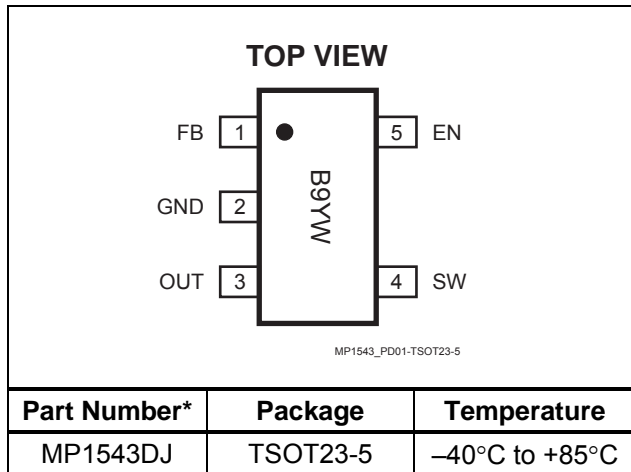

\* For Tape & Reel, add suffix -Z (eg. MP1543DJ-Z)  
 For Lead Free, add suffix -LF (eg. MP1543DJ-LF-Z)

### ABSOLUTE MAXIMUM RATINGS <sup>(1)</sup>

All Pins.....-0.3V to +6.5V  
 Storage Temperature .....-65°C to +150°C

### Recommended Operating Conditions <sup>(2)</sup>

Supply Voltage  $V_{IN}$ ..... 1.8V to 6V  
 Output Voltage  $V_{OUT}$  ..... 2.5V to 6V  
 Operating Temperature .....-40°C to +85°C

### Thermal Resistance <sup>(3)</sup>

$\theta_{JA}$   $\theta_{JC}$   
 TSOT23-5..... 220 .... 110.. °C/W

#### Notes:

- 1) Exceeding these ratings may damage the device.
- 2) The device is not guaranteed to function outside of its operating conditions.
- 3) Measured on approximately 1" square of 1 oz copper.

### ELECTRICAL CHARACTERISTICS

$V_{EN} = V_{OUT} = 3.3V$ ,  $T_A = +25^\circ C$ , unless otherwise noted.

Parameter	Symbol	Condition	Min	Typ	Max	Units
Startup Supply Voltage	$V_{ST}$	$I_{LOAD} = 0mA$	1.5	1.6	1.8	V
		$R_{LOAD} = 50\Omega$		1.7		
Output Voltage Range	$V_{OUT}$		2.5		6.0	V
Supply Current (Shutdown)		$V_{EN} = V_{OUT} 0V$ , $V_{SW} = 5V$		1		$\mu A$
Supply Current		$V_{FB} = 1.3V$		350		$\mu A$
Feedback Voltage	$V_{FB}$			1.2		V
Feedback Input Current		$V_{FB} = 1.2V$		50		nA
Switching Frequency	$f_{SW}$			500		KHz
Maximum Duty Cycle	$D_{MAX}$		80	85	90	%
EN Input Low Voltage					0.4	V
EN Input High Voltage			1.4			V
EN Pull Down Resistor				1		M $\Omega$
Low-Side On Resistance	$R_{ONLS}$	$V_{OUT} = 3.3V$		300		m $\Omega$
Low-Side Current Limit	$I_{LIM}$			1.5		A
High-Side On Resistance	$R_{ONHS}$	$V_{OUT} = 3.3V$		500		m $\Omega$
Thermal Shutdown <sup>(4)</sup>				160		°C
Thermal Shutdown Hysteresis <sup>(4)</sup>				30		°C

#### Note:

4) Guaranteed by design, not tested.

## TYPICAL PERFORMANCE CHARACTERISTICS

Circuit on front page,  $V_{IN} = 2.4V$ ,  $V_{OUT} = 3.3V$ ,  $T_A = +25^{\circ}C$ , unless otherwise noted.

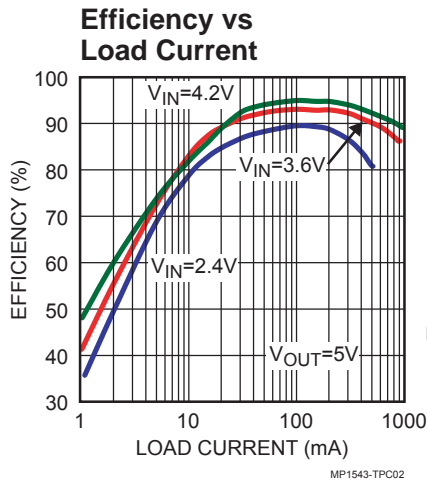
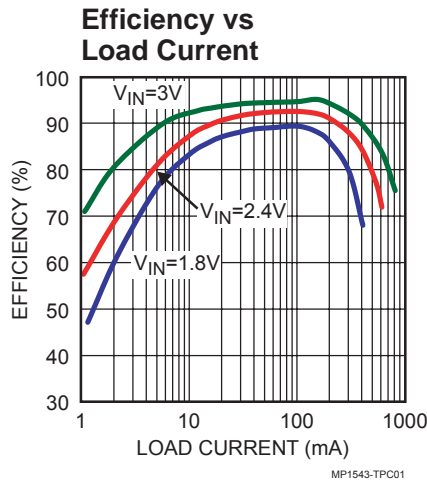

### Discontinuous Mode Operation

$I_{LOAD} = 25mA$

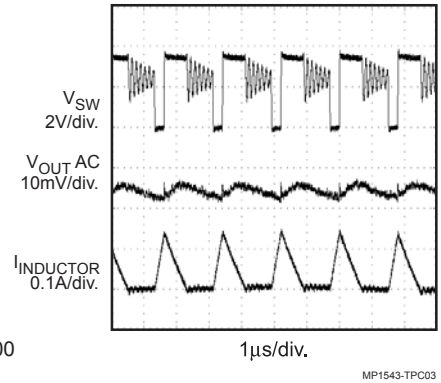

### Continuous Mode Operation

$I_{LOAD} = 400mA$

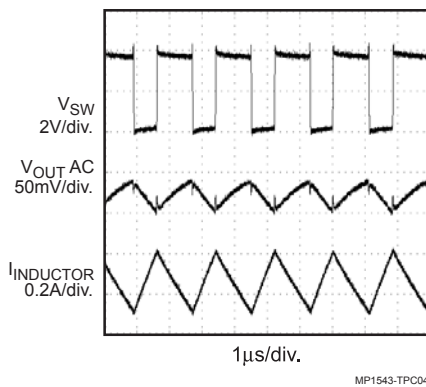

### Transient Response

$I_{LOAD} = 40mA$  to  $400mA$  Step  
w/o Feed-Forward Capacitor

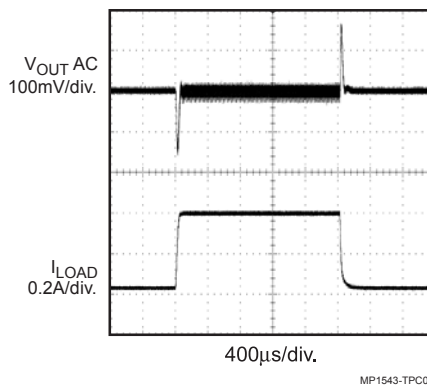

### Transient Response

$I_{LOAD} = 40mA$  to  $400mA$  Step  
with 220pF Feed-Forward Capacitor

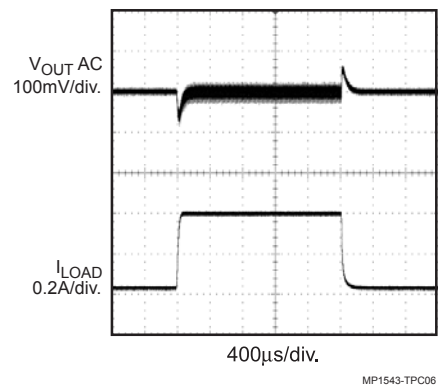

### Startup

$R_{LOAD} = 16\Omega$

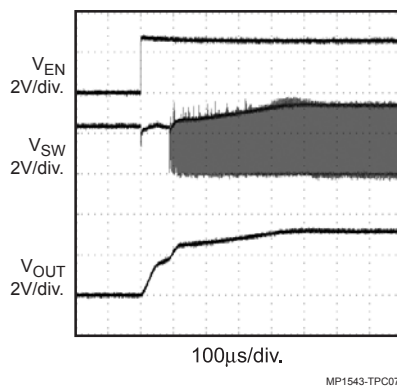

### Feedback Voltage vs Temperature

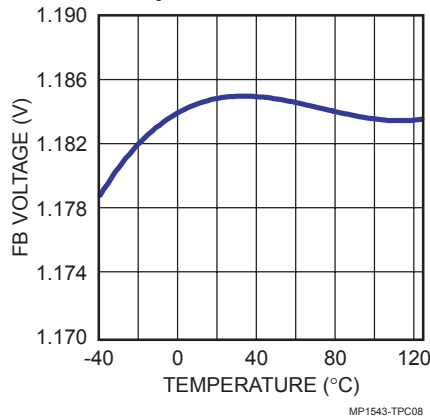

### Switching Frequency vs Temperature

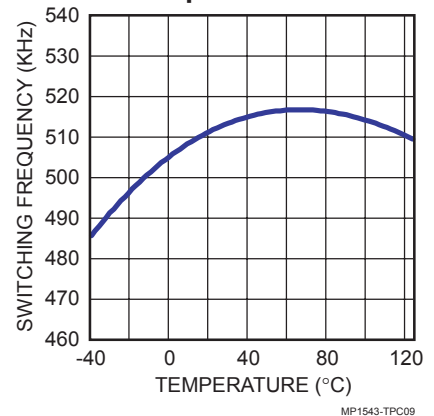

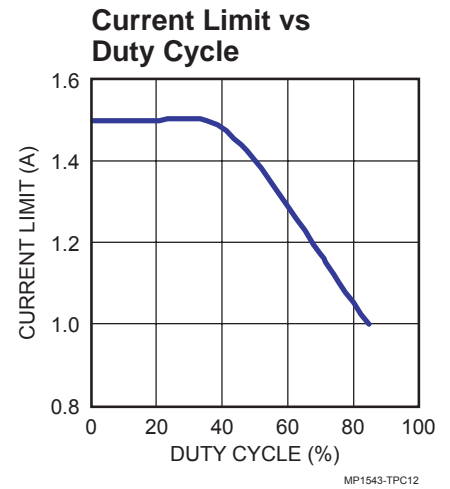
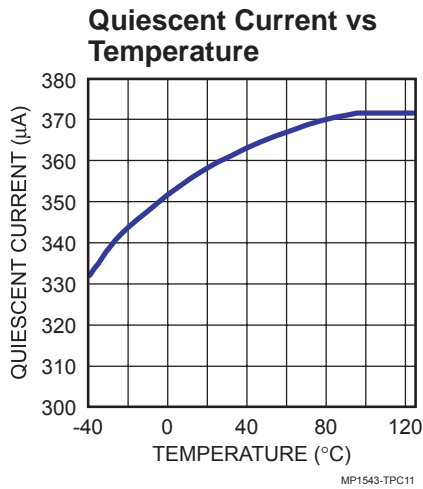
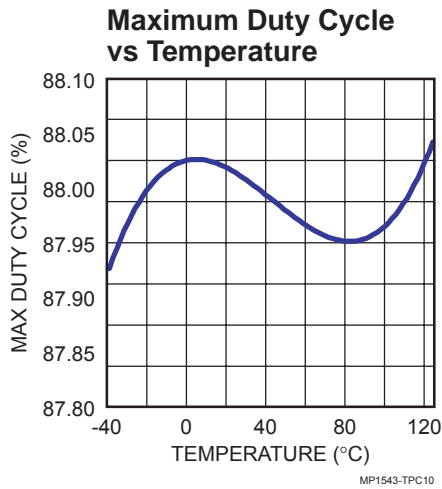
**TYPICAL PERFORMANCE CHARACTERISTICS (continued)**

**PIN FUNCTIONS**

Pin #	Name	Description
1	FB	Regulation Feedback Input. Connect to an external resistive voltage divider from the output to FB to set the output voltage.
2	GND	Ground.
3	OUT	Supply Input for the MP1543. Connect to the output of the converter.
4	SW	Output Switching Node. SW is the drain of the internal low-side N-Channel MOSFET and high-side P-Channel MOSFET. Connect the inductor to SW to complete the step-up converter.
5	EN	Regulator On/Off Control Input. A logic high input ( $V_{EN} > 1.4V$ ) turns on the regulator. A logic low input ( $V_{EN} < 0.4V$ ) puts the MP1543 into low current shutdown mode.

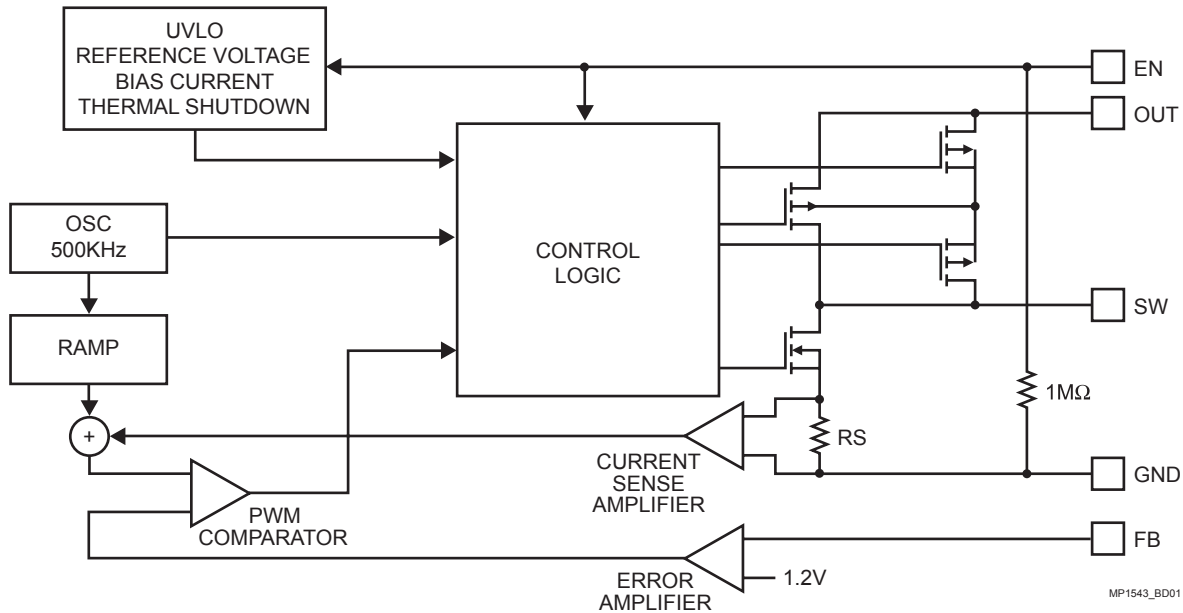
## OPERATION



**Figure 1—Functional Block Diagram**

The MP1543 uses a 500kHz fixed-frequency, current-mode regulation architecture to regulate the output voltage. The MP1543 measures the output voltage through an external resistive voltage divider and compares that to the internal 1.2V reference to generate the error voltage. The current-mode regulator compares the error voltage to the inductor current to regulate the output voltage. The use of current-mode regulation improves transient response and control loop stability.

When the MP1543 is disabled (EN = Low), both power switches are off. The body of the P-Channel MOSFET connects to SW and there is no current path from SW to OUT. Therefore, the output voltage discharges to ground. When the MP1543 is enabled (EN = High), the body of the P-Channel MOSFET connects to OUT and forms a forward diode from SW to OUT. Thus the output voltage rises up toward the input voltage. When output voltage crosses 1.6V the MP1543 starts the controller and regulates the output voltage to the target value.

At the beginning of each cycle, the N-Channel MOSFET switch is turned on, forcing the inductor current to rise. The current at the source of the switch is internally measured and converted to a voltage by the current sense amplifier. That voltage is compared to the error voltage. When the inductor current rises sufficiently, the PWM comparator turns off the switch, forcing the inductor current to the output capacitor through the internal P-Channel MOSFET rectifier, which forces the inductor current to decrease. The peak inductor current is controlled by the error voltage, which in turn is controlled by the output voltage. Thus the output voltage controls the inductor current to satisfy the load.

### Soft-Start

The MP1543 includes a soft-start timer that limits the voltage at the error amplifier output during startup to prevent excessive current at the input. This prevents premature termination of the source voltage at startup due to inrush current. This also limits the inductor current at startup, forcing the input current to rise slowly to the amount required to regulate the output voltage during soft-start.

## APPLICATION INFORMATION

### COMPONENT SELECTION

#### Setting the Output Voltage

Set the output voltage by selecting the resistive voltage divider ratio. The voltage divider drops the output voltage to the 1.2V feedback voltage. Use a 100kΩ resistor for R2 of the voltage divider. Determine the high-side resistor R1 by the equation:

$$R1 = \frac{V_{OUT} - V_{FB}}{\left(\frac{V_{FB}}{R2}\right)}$$

Where  $V_{OUT}$  is the output voltage,  $V_{FB}$  is the 1.2V feedback voltage and  $R2=100k\Omega$ .

#### Selecting the Input Capacitor

An input capacitor is required to supply the AC ripple current to the inductor, while limiting noise at the input source. Multi-layer ceramic capacitors are the best choice as they have extremely low ESR and are available in small footprints. Use an input capacitor value of 4.7μF or greater. This capacitor must be placed physically close to the device.

#### Selecting the Output Capacitor

A single 4.7μF to 10μF ceramic capacitor usually provides sufficient output capacitance for most applications. Larger values up to 22μF may be used to obtain extremely low output voltage ripple and improve transient response. The impedance of the ceramic capacitor at the switching frequency is dominated by the capacitance, and so the output voltage ripple is mostly independent of the ESR. The output voltage ripple  $V_{RIPPLE}$  is calculated as:

$$V_{RIPPLE} = \frac{I_{LOAD}(V_{OUT} - V_{IN})}{V_{OUT} \times C2 \times f_{SW}}$$

Where  $V_{IN}$  is the input voltage,  $I_{LOAD}$  is the load current,  $C2$  is the capacitance of the output capacitor and  $f_{SW}$  is the 500KHz switching frequency.

#### Selecting the Inductor

The inductor is required to force the output voltage higher while being driven by the lower input voltage. A good rule for determining the inductance is to allow the peak-to-peak ripple current to be approximately 30%-50% of the maximum input current. Make sure that the peak inductor current is below the minimum current limit at the duty cycle used (to prevent loss of regulation due to the current limit variations).

Calculate the required inductance value L using the equations:

$$L = \frac{V_{IN} \times (V_{OUT} - V_{IN})}{V_{OUT} \times f_{SW} \times \Delta I}$$

$$I_{IN(MAX)} = \frac{V_{OUT} \times I_{LOAD(MAX)}}{V_{IN} \times \eta}$$

$$\Delta I = (30\% - 50\%) I_{IN(MAX)}$$

Where  $I_{LOAD(MAX)}$  is the maximum load current,  $\Delta I$  is the peak-to-peak inductor ripple current and  $\eta$  is efficiency. For the MP1543, typically, 4.7μH is recommended for most applications. Choose an inductor that does not saturate at the peak switch current as calculated above with additional margin to cover heavy load transients and extreme startup conditions.

### Selecting the Feed-Forward Capacitor

A feed-forward capacitor C3 in parallel with the high-side resistor R1 can be added to improve the output ripple at discontinuous conduction mode and the load transient response (see Figure 2). Up to 220pF for this capacitor is recommended for 3.3V output applications.

### Selecting the Schottky Diode

A Schottky diode D1 in parallel with the high-side P-Channel MOSFET is necessary to clamp the SW node to a safe level for outputs of 4V or above. A 0.5A, 20V Schottky diode can be used for this purpose. See Figure 3.

### LAYOUT CONSIDERATIONS

High frequency switching regulators require very careful layout for stable operation and low noise. All components must be placed as close to the IC as possible. All feedback components must be kept close to the FB pin to prevent noise injection on the FB pin trace. The ground return of C1 and C2 should be tied close to the GND pin. See the MP1543 demo board layout for reference.

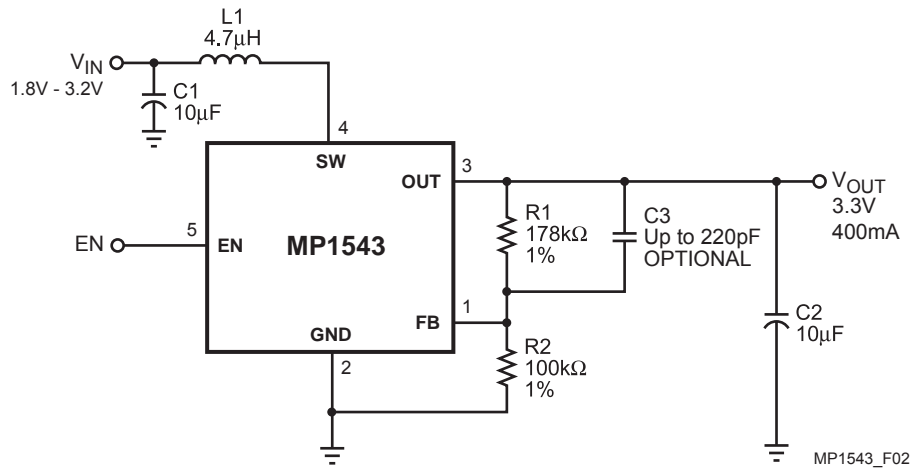

**Figure 2—3.3V Typical Application Circuit with Feed-Forward Capacitor**

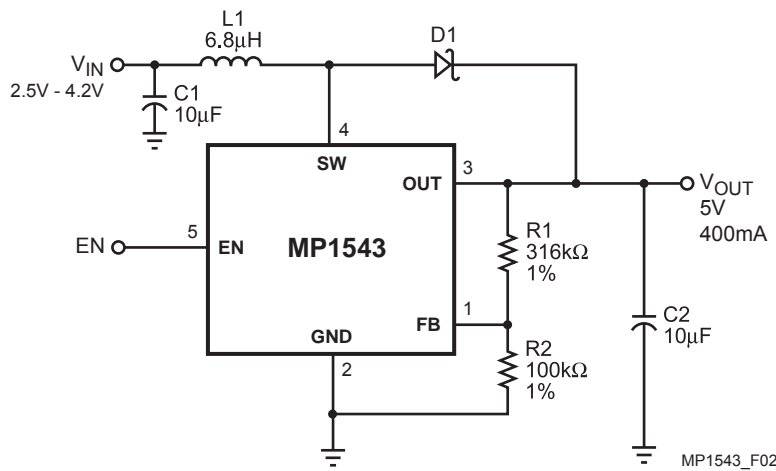

**Figure 3—5V Typical Application Circuit with External Schottky Diode and Output Disconnect Not Required**

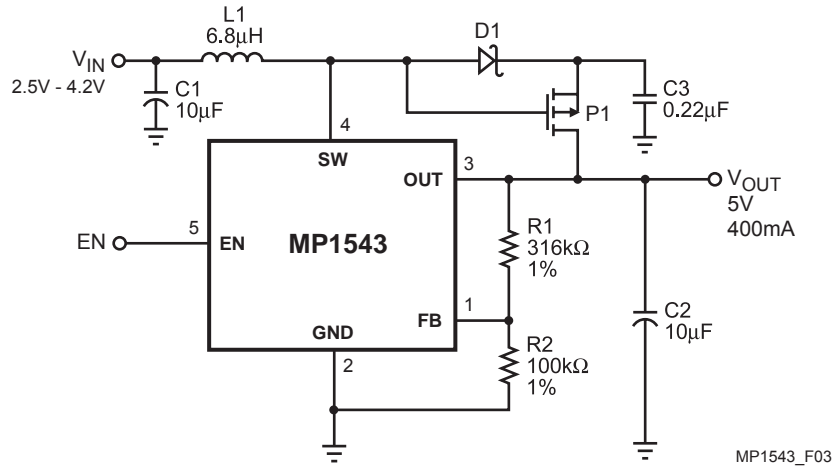
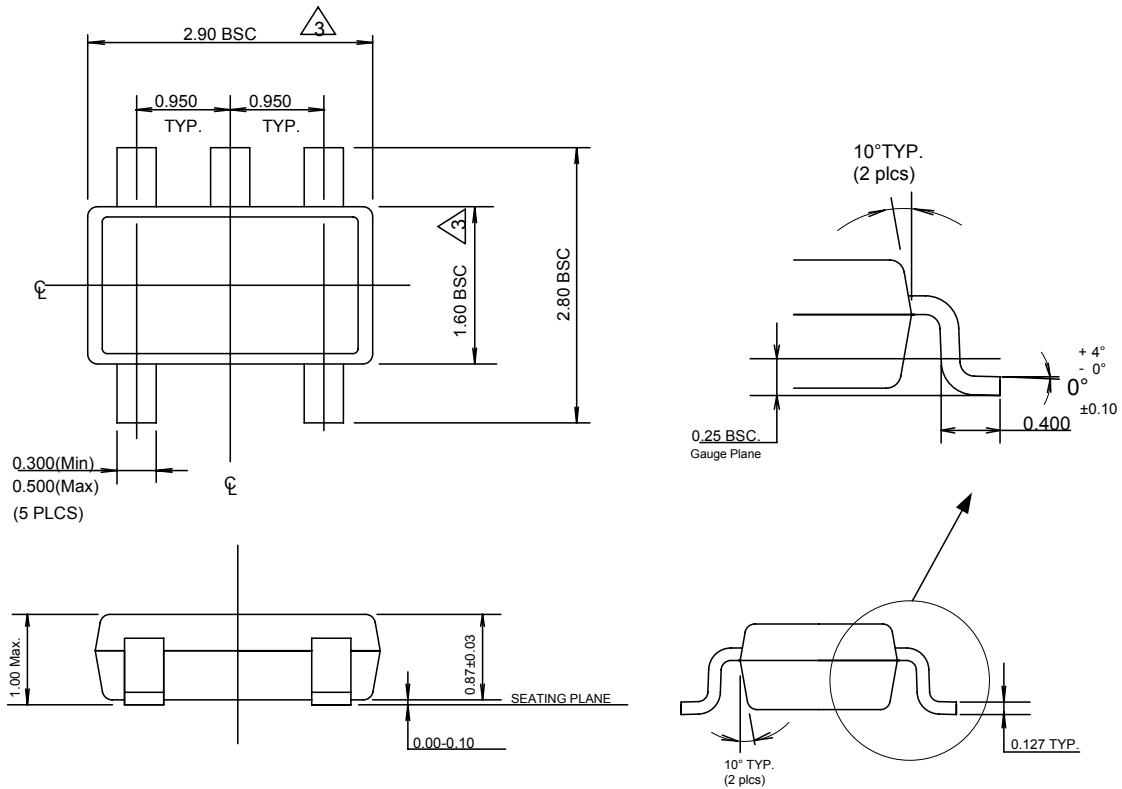

Figure 4—5V Typical Application Circuit with External Schottky Diode and Output Disconnect Required



# PACKAGE INFORMATION

## TSOT23-5



Dimensions are in millimeters

**NOTE:**

1. Dimensions and tolerances are as per ANSI Y14.5M, 1994.
2. Die is facing up for mold. Die is facing down for trim/form, ie. reverse trim/form.
3. Dimensions are exclusive of mold flash and gate burr.
4. The footlength measuring is based on the gauge plane method.
5. All specification comply to Jedec Spec MO193 Issue C.

**NOTICE:** The information in this document is subject to change without notice. Please contact MPS for current specifications. Users should warrant and guarantee that third party Intellectual Property rights are not infringed upon when integrating MPS products into any application. MPS will not assume any legal responsibility for any said applications.