

## +3.3V Low Power Half-Duplex RS-485 Transceivers with 10Mbps Data Rate

- RS-485 and RS-422 Transceivers
- Operates from a single +3.3V supply
- Interoperable with +5.0V logic
- Driver/Receiver Enable
- Low Power Shutdown Mode (SP3481)
- -7V to +12V Common-Mode Input Voltage Range
- Allows up to 32 transceivers on the serial bus
- Compatibility with the industry standard 75176 pinout
- Driver Output Short-Circuit Protection

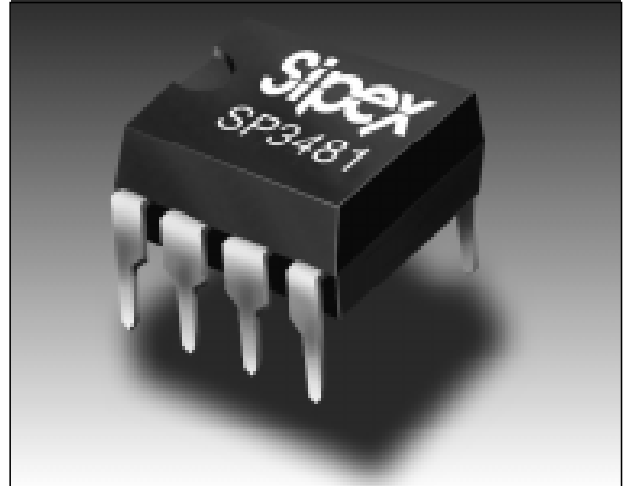

### DESCRIPTION

The **SP3481** and the **SP3485** are a family of +3.3V low power half-duplex transceivers that meet the specifications of the RS-485 and RS-422 serial protocols. These devices are pin-to-pin compatible with the Sipex SP481, SP483, and SP485 devices as well as popular industry standards. The **SP3481** and the **SP3485** feature Sipex's BiCMOS process, allowing low power operation without sacrificing performance. The **SP3481** and **SP3485** meet the electrical specifications of RS-485 and RS-422 serial protocols up to 10Mbps under load. The **SP3481** is equipped with a low power Shutdown mode.

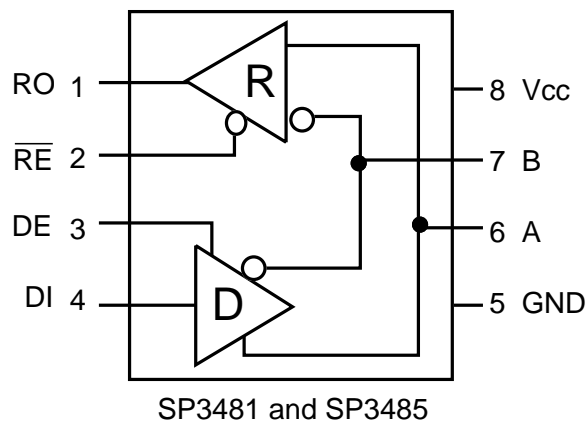

## ABSOLUTE MAXIMUM RATINGS

These are stress ratings only and functional operation of the device at these ratings or any other above those indicated in the operation sections of the specifications below is not implied. Exposure to absolute maximum rating conditions for extended periods of time may affect reliability.

$V_{CC}$ .....	+7V
Input Voltages	
Logic.....	-0.3V to ( $V_{CC}+0.5V$ )
Drivers.....	-0.3V to ( $V_{CC}+0.5V$ )
Receivers.....	$\pm 15V$
Output Voltages	
Logic.....	-0.3V to ( $V_{CC}+0.5V$ )
Drivers.....	$\pm 15V$
Receivers.....	-0.3V to ( $V_{CC}+0.5V$ )
Storage Temperature.....	-65°C to +150°C
Power Dissipation per Package	
8-pin NSOIC (derate 6.90mW/°C above +70°C).....	600mW
8-pin PDIP (derate 11.8mW/°C above +70°C).....	1000mW



**CAUTION:**  
ESD (ElectroStatic Discharge) sensitive device. Permanent damage may occur on unconnected devices subject to high energy electrostatic fields. Unused devices must be stored in conductive foam or shunts. Personnel should be properly grounded prior to handling this device. The protective foam should be discharged to the destination socket before devices are removed.

## SPECIFICATIONS

$T_{AMB} = T_{MIN}$  to  $T_{MAX}$  and  $V_{CC} = +3.3V \pm 5\%$  unless otherwise noted.

PARAMETERS	MIN.	TYP.	MAX.	UNITS	CONDITIONS
<b>SP3481/SP3485 DRIVER</b>					
<b>DC Characteristics</b>					
Differential Output Voltage	GND		$V_{CC}$	Volts	Unloaded; $R = \infty$ ; <i>Figure 1</i>
Differential Output Voltage	2		$V_{CC}$	Volts	with load; $R = 50\Omega$ ; (RS-422); <i>Figure 1</i>
Differential Output Voltage Change in Magnitude of Driver	1.5		$V_{CC}$	Volts	with load; $R = 27\Omega$ ; (RS-485); <i>Figure 1</i>
Differential Output Voltage for Complimentary States			0.2	Volts	$R = 27\Omega$ or $R = 50\Omega$ ; <i>Figure 1</i>
Driver Common-Mode Output Voltage			3	Volts	$R = 27\Omega$ or $R = 50\Omega$ ; <i>Figure 1</i>
Input High Voltage	2.0			Volts	Applies to DE, DI, $\overline{RE}$
Input Low Voltage			0.8	Volts	Applies to DE, DI, $\overline{RE}$
Input Current			$\pm 10$	$\mu A$	Applies to DE, DI, $\overline{RE}$
Driver Short-Circuit Current					
$V_{OUT} = HIGH$			$\pm 250$	mA	$-7V \leq V_O \leq +12V$
$V_{OUT} = LOW$			$\pm 250$	mA	$-7V \leq V_O \leq +12V$
<b>SP3481/SP3485 DRIVER</b>					
<b>AC Characteristics</b>					
Maximum Data Rate	10			Mbps	$\overline{RE} = V_{CC}$ , $DE = V_{CC}$
Driver Input to Output, $t_{PLH}$	20	40	60	ns	<i>Figures 2 and 8</i>
Driver Input to Output, $t_{PHL}$	20	40	60	ns	<i>Figures 2 and 8</i>
Differential Driver Skew		2	10	ns	$ t_{DO1} - t_{DO2} $ <i>Figures 2 and 9</i>
Driver Rise or Fall Time		5	20	ns	From 10% to 90% ; <i>Figures 3 and 9</i>
Driver Enable to Output High		52	120	ns	<i>Figures 4 and 10</i>
Driver Enable to Output Low		60	120	ns	<i>Figures 5 and 10</i>
Driver Disable Time from Low		40	120	ns	<i>Figures 5 and 10</i>
Driver Disable Time from High		60	120	ns	<i>Figures 4 and 10</i>
<b>SP3481/SP3485 RECEIVER</b>					
<b>DC Characteristics</b>					
Differential Input Threshold	-0.2		+0.2	Volts	$-7V \leq V_{CM} \leq +12V$
Input Hysteresis		20		mV	$V_{CM} = 0V$
Output Voltage High	$V_{CC}-0.4$			Volts	$V_{ID} = +200mV, -1.5mA$
Output Voltage Low			0.4	Volts	$V_{ID} = -200mV, 2.5mA$
Three-State (High Impedance) Output Current			$\pm 1$	$\mu A$	$0V \leq V_O \leq V_{CC}$ ; $\overline{RE} = V_{CC}$
Input Resistance	12	15		k $\Omega$	$-7V \leq V_{CM} \leq +12V$
Input Current (A, B); $V_{IN} = 12V$			1.0	mA	$DE = 0V, V_{CC} = 0V$ or $3.6V, V_{IN} = 12V$
Input Current (A, B); $V_{IN} = -7V$			-0.8	mA	$DE = 0V, V_{CC} = 0V$ or $3.6V, V_{IN} = -7V$
Short-Circuit Current	7		60	mA	$0V \leq V_{CM} \leq V_{CC}$

## SPECIFICATIONS (continued)

$T_{AMB} = T_{MIN}$  to  $T_{MAX}$  and  $V_{CC} = +3.3V \pm 5\%$  unless otherwise noted.

PARAMETERS	MIN.	TYP.	MAX.	UNITS	CONDITIONS
<b>SP3481/SP3485 RECEIVER</b>					
<b>AC Characteristics</b>					
Maximum Data Rate	10			Mbps	$\overline{RE} = 0V, DE = 0V$ <i>Figures 6 and 11</i>
Receiver Input to Output, $t_{PLH}$	40	70	100 70	ns ns	$T_{AMB} = +25^{\circ}C, V_{CC} = +3.3V,$ <i>Figures 6 and 11</i>
Receiver Input to Output, $t_{PHL}$	40	70	100 70	ns ns	<i>Figures 6 and 11</i> $T_{AMB} = +25^{\circ}C, V_{CC} = +3.3V,$ <i>Figures 6 and 11</i>
Differential Receiver Skew		4		ns	$t_{RSKEW} =  t_{RPHL} - t_{RPLH} $ <i>Figures 6 and 11</i>
Receiver Enable to Output Low		35	60	ns	<i>Figures 7 and 12; S<sub>1</sub> closed, S<sub>2</sub> open</i>
Receiver Enable to Output High		35	60	ns	<i>Figures 7 and 12; S<sub>2</sub> closed, S<sub>1</sub> open</i>
Receiver Disable from Low		35	60	ns	<i>Figures 7 and 12; S<sub>1</sub> closed, S<sub>2</sub> open</i>
Receiver Disable from High		35	60	ns	<i>Figures 7 and 12; S<sub>2</sub> closed, S<sub>1</sub> open</i>
<b>SP3481 Shutdown Timing</b>					
Time to Shutdown	50	75	200	ns	$\overline{RE} = 3.3V, DE = 0V$
Driver Enable from Shutdown to Output High		65	150	ns	<i>Figures 4 and 10</i>
Driver Enable from Shutdown to Output Low		65	150	ns	<i>Figures 5 and 10</i>
Receiver Enable from Shutdown to Output High		50	200	ns	<i>Figures 7 and 12; S<sub>2</sub> closed, S<sub>1</sub> open</i>
Receiver Enable from Shutdown to Output Low		50	200	ns	<i>Figures 7 and 12; S<sub>1</sub> closed, S<sub>2</sub> open</i>
<b>POWER REQUIREMENTS</b>					
Supply Current					
<b>SP3481/3485</b>					
No Load		1000 800	2000 1500	$\mu A$ $\mu A$	$\overline{RE}, DI = 0V$ or $V_{CC}$ ; $DE = V_{CC}$ $\overline{RE} = 0V, DI = 0V$ or $V_{CC}$ ; $DE = 0V$
<b>SP3481</b>			10	$\mu A$	$DE = 0V, \overline{RE} = V_{CC}$
Shutdown Mode					

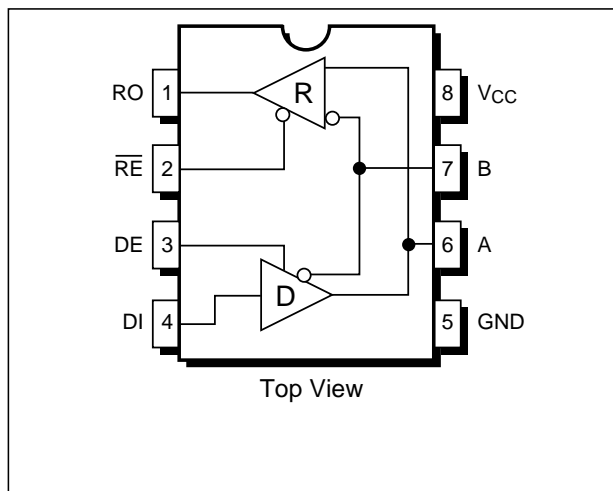

**SP3481/SP3485**  
Pinout (Top View)

## DESCRIPTION

The **SP3481** and the **SP3485** are 2 members in the family of +3.3V low power half-duplex transceivers that meet the specifications of the RS-485 and RS-422 serial protocols. These devices are pin-to-pin compatible with the Sipex SP481, SP483, and SP485 devices as well as popular industry standards. The **SP3481** and the **SP3485** feature Sipex's BiCMOS process allowing low power operation without sacrificing performance.

## Drivers

The driver outputs of the **SP3481** and **SP3485** are differential outputs meeting the RS-485 and RS-422 standards. The typical voltage output swing with no load will be 0 Volts to +3.3 Volts. With a load of 54Ω across the differential outputs, the drivers maintain greater than 1.5V voltage levels. The drivers of the **SP3481** and **SP3485** have an enable control line which is active HIGH. A logic HIGH on DE (pin 3) will enable the differential driver outputs. A logic LOW on DE (pin 3) will tri-state the driver outputs.

The transceivers in the **SP3481** and **SP3485** operate up to 10Mbps. The 250mA  $I_{SC}$  maximum limit on the driver output allows the **SP3481** and the **SP3485** to withstand an infinite short circuit over the -7.0V to +12.0V common mode range without catastrophic damage to the IC.

## PIN FUNCTION

Pin 1 – RO – Receiver Output.

Pin 2 –  $\overline{RE}$  – Receiver Output Enable Active LOW.

Pin 3 – DE – Driver Output Enable Active HIGH.

Pin 4 – DI – Driver Input.

Pin 5 – GND – Ground Connection.

Pin 6 – A – Driver Output/Receiver Input Non-inverting.

Pin 7 – B – Driver Output/Receiver Input Inverting.

Pin 8 –  $V_{CC}$

## Receivers

The **SP3481** and **SP3485** receivers have differential inputs with an input sensitivity as low as  $\pm 200\text{mV}$ . Input impedance of the receivers is typically 15kΩ (12kΩ minimum). A wide common mode range of -7V to +12V allows for large ground potential differences between systems. The receivers of the **SP3481** and **SP3485** have a tri-state enable control pin. A logic LOW on  $\overline{RE}$  (pin 2) will enable the receiver, a logic HIGH on  $\overline{RE}$  (pin 2) will disable the receiver.

The receivers of the **SP3481** and **SP3485** operate up to 10Mbps. The receiver for each of the three devices is equipped with fail-safe. Fail-safe guarantees that the receiver output will be in a HIGH state when the input is left unconnected.

## Shutdown Mode for the SP3481

The **SP3481** is equipped with a Shutdown mode. To enable the Shutdown state, both the driver and receiver must be disabled simultaneously. A logic LOW on DE (pin 3) and a logic HIGH on  $\overline{RE}$  (pin 2) will put the **SP3481** into Shutdown mode. In Shutdown, supply current will drop to typical 1μA, 10μA maximum.

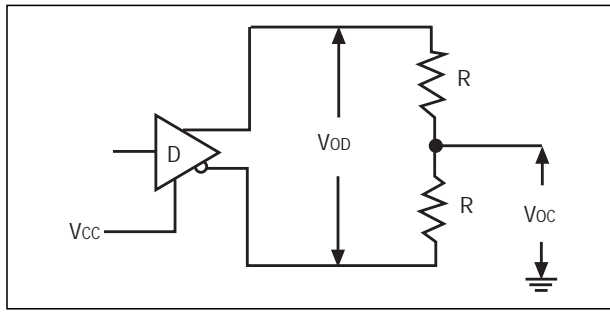

Figure 1. Driver DC Test Load Circuit

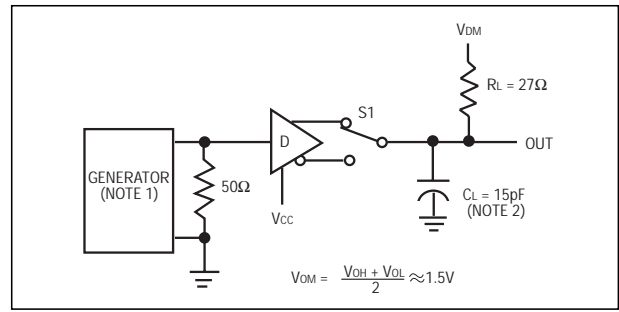

Figure 2. Driver Propagation Delay Test Circuit

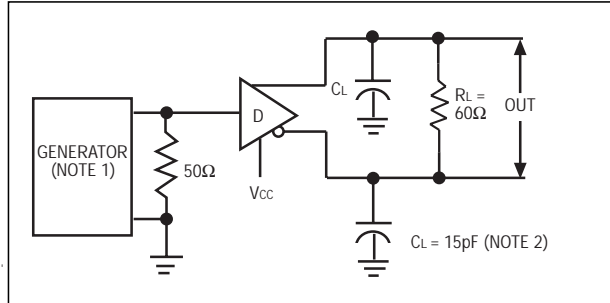

Figure 3. Driver Differential Output Delay and Transition Time Circuit

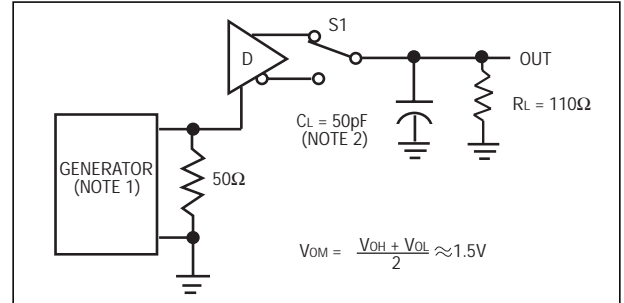

Figure 4. Driver Enable and Disable Timing Circuit, Output HIGH

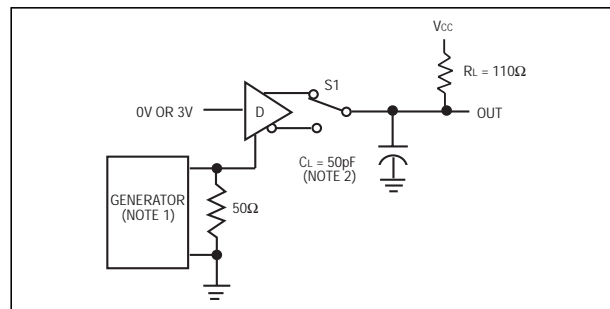

Figure 5. Driver Enable and Disable Timing Circuit, Output LOW

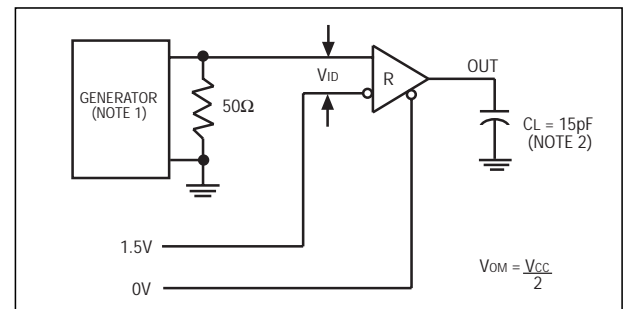

Figure 6. Receiver Propagation Delay Test Circuit

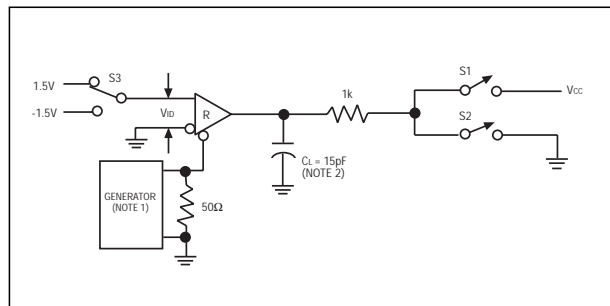

Figure 7. Receiver Enable and Disable Timing Circuit

INPUTS			LINE CONDITION	OUTPUTS	
$\overline{\text{RE}}$	DE	DI		B	A
X	1	1	No Fault	0	1
X	1	0	No Fault	1	0
X	0	X	X	Z	Z

Table 1. Transmit Function Truth Table

INPUTS		A - B	OUTPUTS
$\overline{\text{RE}}$	DE		R
0	0	+0.2V	1
0	0	-0.2V	0
0	0	Inputs Open	1
1	0	X	Z

Table 2. Receive Function Truth Table

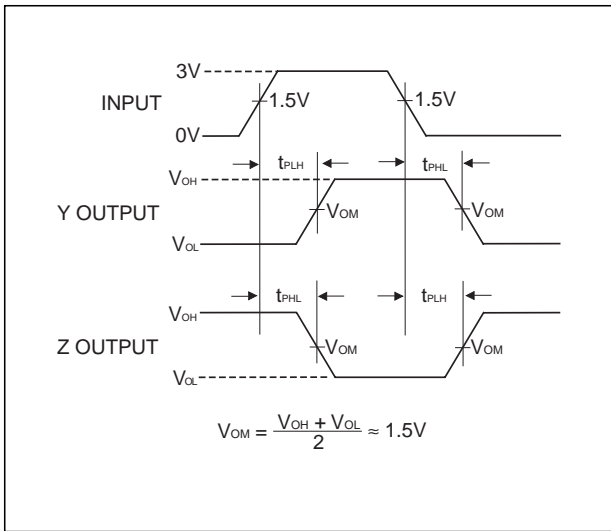

**Figure 8. Driver Propagation Delay Waveforms**

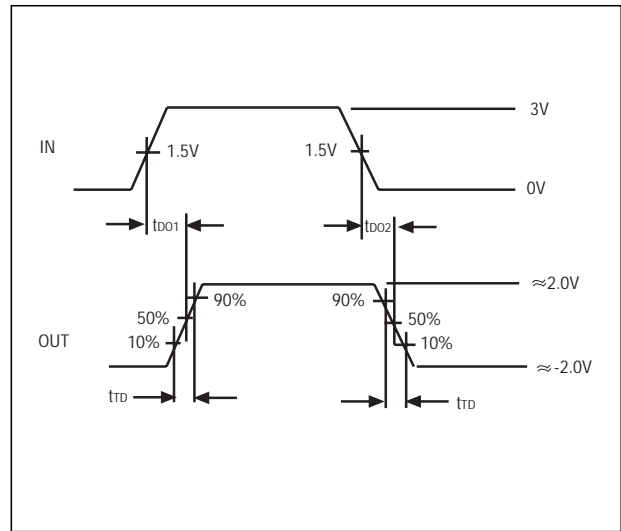

**Figure 9. Driver Differential Output Delay and Transition Time Waveforms**

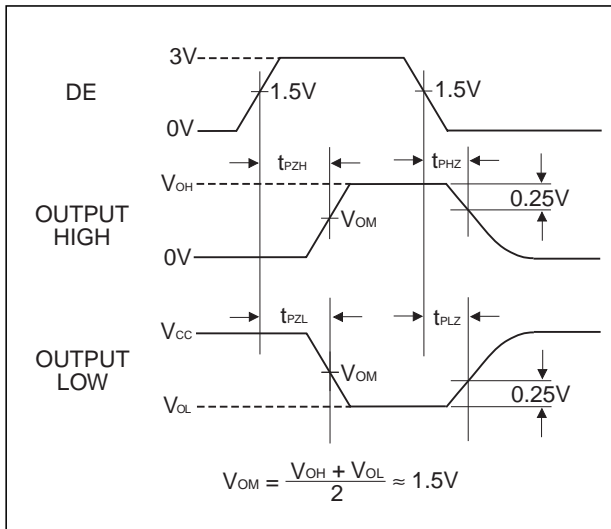

**Figure 10. Driver Enable and Disable Timing Waveforms**

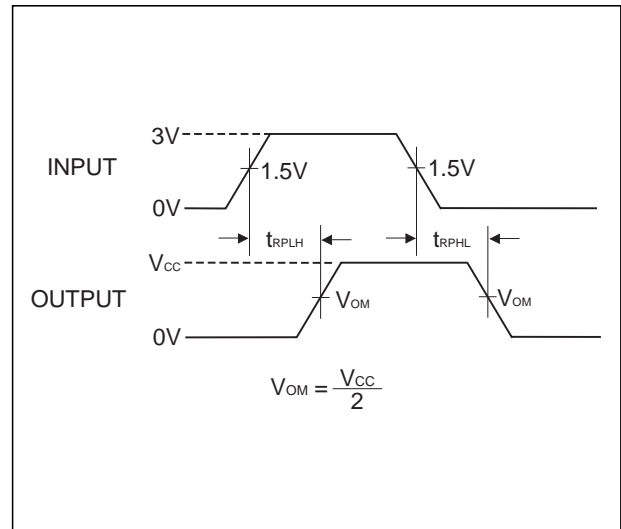

**Figure 11. Receiver Propagation Delay Waveforms**

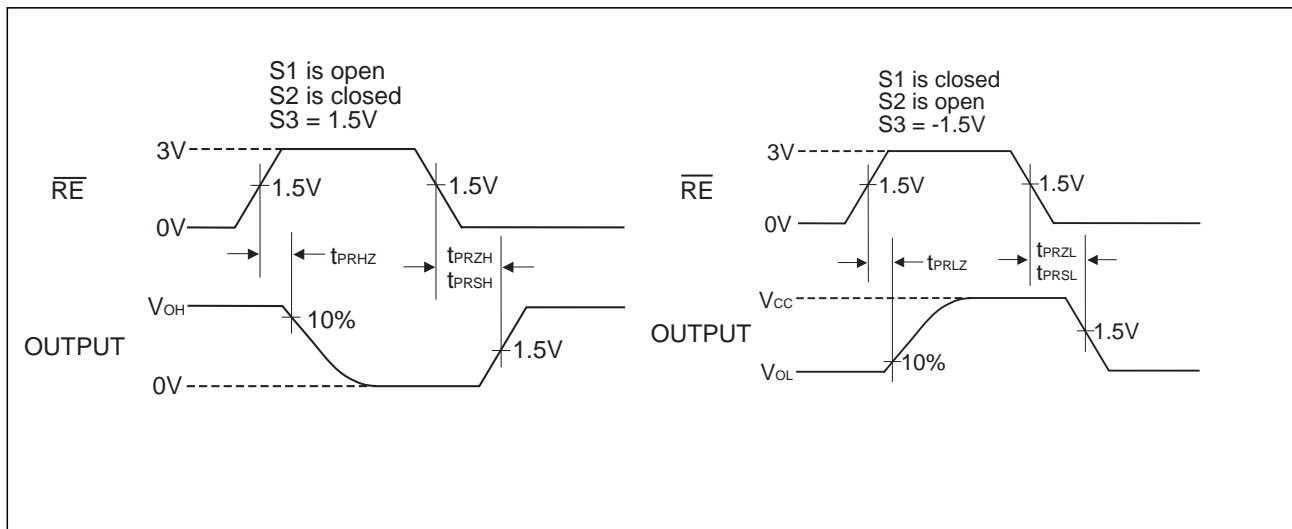

**Figure 12. Receiver Enable and Disable Waveforms**

**NOTE 1:** The input pulse is supplied by a generator with the following characteristics:

PRR=250KHz, 50% duty cycle,  $t_r < 6.0ns$ ,  $Z_0=50\Omega$ .

**NOTE 2:**  $C_L$  includes probe and stray capacitance.

**PACKAGE: PLASTIC  
DUAL-IN-LINE  
(NARROW)**

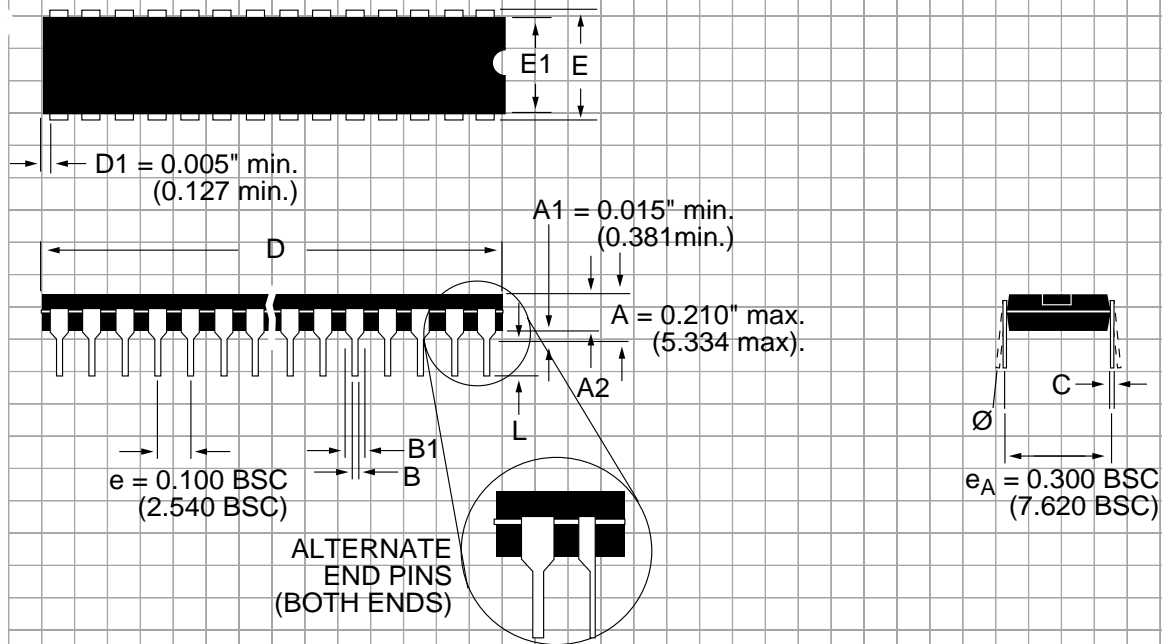

DIMENSIONS (Inches) Minimum/Maximum (mm)	8-PIN
A2	0.115/0.195 (2.921/4.953)
B	0.014/0.022 (0.356/0.559)
B1	0.045/0.070 (1.143/1.778)
C	0.008/0.014 (0.203/0.356)
D	0.355/0.400 (9.017/10.160)
E	0.300/0.325 (7.620/8.255)
E1	0.240/0.280 (6.096/7.112)
L	0.115/0.150 (2.921/3.810)
Ø	0°/15° (0°/15°)

**PACKAGE: PLASTIC  
SMALL OUTLINE (SOIC)  
(NARROW)**

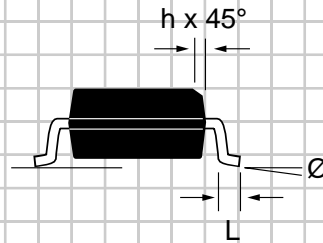
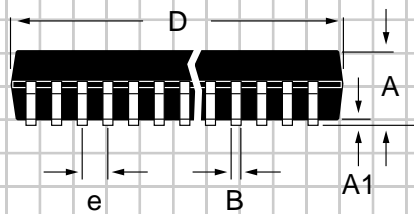
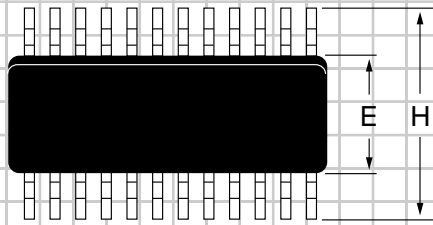

DIMENSIONS (Inches) Minimum/Maximum (mm)	8-PIN
A	0.053/0.069 (1.346/1.748)
A1	0.004/0.010 (0.102/0.249)
B	0.014/0.019 (0.35/0.49)
D	0.189/0.197 (4.80/5.00)
E	0.150/0.157 (3.802/3.988)
e	0.050 BSC (1.270 BSC)
H	0.228/0.244 (5.801/6.198)
h	0.010/0.020 (0.254/0.498)
L	0.016/0.050 (0.406/1.270)
Ø	0°/8° (0°/8°)



## ORDERING INFORMATION

Model	Temperature Range	Package
SP3481CN .....	0°C to +70°C .....	8-pin Narrow SOIC
SP3481CP .....	0°C to +70°C .....	8-pin Plastic DIP
SP3481EN .....	-40°C to +85°C .....	8-pin Narrow SOIC
SP3481EP .....	-40°C to +85°C .....	8-pin Plastic DIP
SP3485CN .....	0°C to +70°C .....	8-pin Narrow SOIC
SP3485CP .....	0°C to +70°C .....	8-pin Plastic DIP
SP3485EN .....	-40°C to +85°C .....	8-pin Narrow SOIC
SP3485EP .....	-40°C to +85°C .....	8-pin Plastic DIP

Please consult the factory for pricing and availability on a Tape-On-Reel option.



SIGNAL PROCESSING EXCELLENCE

### Sipex Corporation

#### Headquarters and Sales Office

22 Linnell Circle  
Billerica, MA 01821  
TEL: (978) 667-8700  
FAX: (978) 670-9001  
e-mail: sales@sipex.com

#### Sales Office

233 South Hillview Drive  
Milpitas, CA 95035  
TEL: (408) 934-7500  
FAX: (408) 935-7600

Sipex Corporation reserves the right to make changes to any products described herein. Sipex does not assume any liability arising out of the application or use of any product or circuit described hereing; neither does it convey any license under its patent rights nor the rights of others.