

24-Bit Mux/Demux Bus Switch

Features

- Near-zero propagation delay
- 5Ω switches connect inputs to outputs
- Direct bus connection when switches are ON
- Internal 500Ω pull-down on A2 ports
- Ultra-low quiescent power (0.2μA typical)
– Ideally suited for notebook applications
- Industrial operating temperature: -40°C to +85°C
- Make-before-break switching
- Packages available:
 - 56-pin 240-mil wide thin plastic TSSOP (A)
 - 56-pin 300-mil wide plastic SSOP (V)

Applications

- Memory switching

Logic Block Diagram

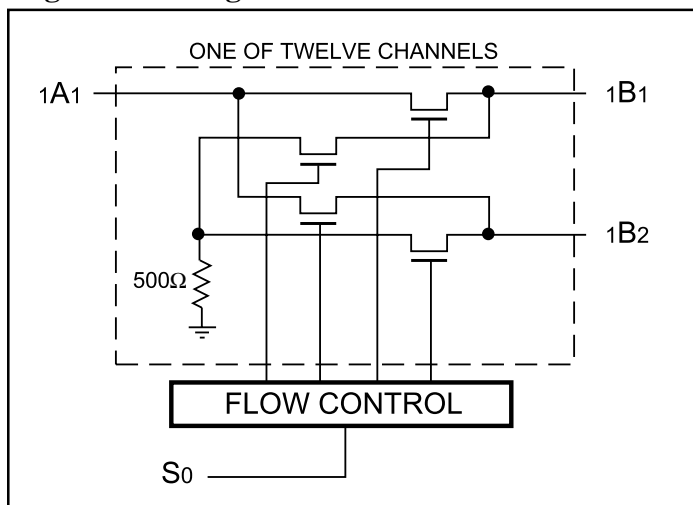

Truth Table

Function	S0	A1	A2
A1 to B1, A2 to B2	L	B1	B2
A1 to B2, A2 to B1	H	B2	B1

Note:

1. H = High Voltage Level
L = Low Voltage Level
Z = High Impedance

Description

Pericom Semiconductor's PI5C series of logic circuits are produced using the Company's advanced 0.6 micron CMOS technology.

The PI5C16292 and PI5C162292 are 12-bit to 24-bit Mux/Demux Bus switches designed with a low ON resistance allowing inputs to be connected directly to outputs.

The PI5C162292 device has a built-in 25-ohm series resistor to reduce noise resulting from reflections, thus eliminating the need for an external terminating resistor.

A2 port is not externally connected and, as a result, has an internal 500-ohm pulldown resistor to ground.

Pin Configuration

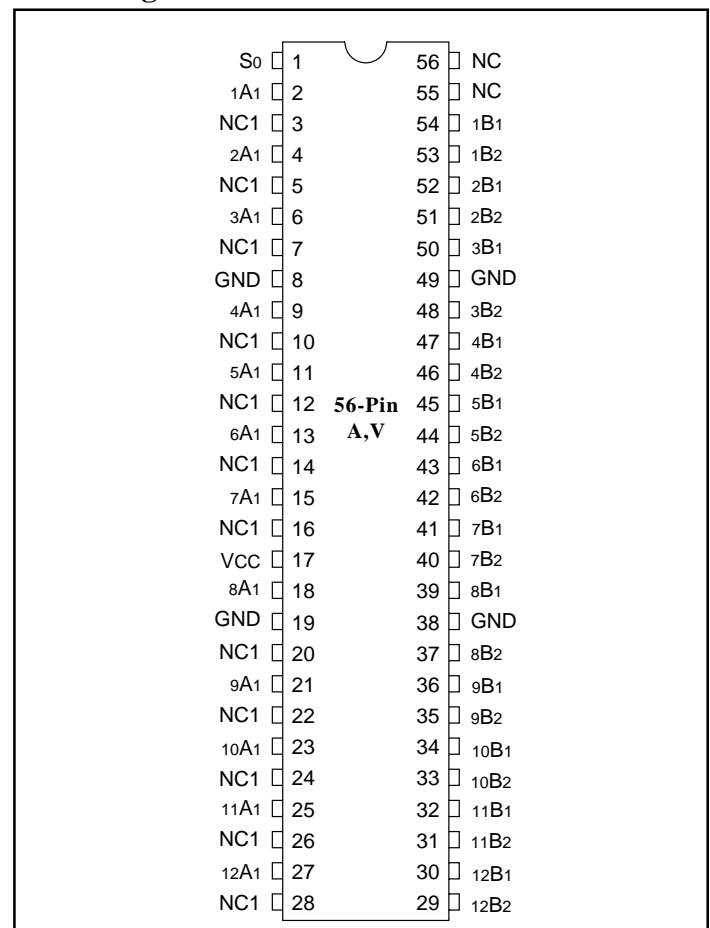

Product Pin Description

Pin Name	I/O	Description
S0	I	Select Inputs
xA1	I/O	Bus A
xBx	I/O	Bus B
NC		Internally pulled up thru 4.7k resistor
NC1		Leave it unconnected

Maximum Ratings

(Above which the useful life may be impaired. For user guidelines, not tested.)

Storage Temperature	-65°C to +150°C
Ambient Temperature with Power Applied	-40°C to +85°C
Supply Voltage to Ground Potential (Inputs & V _{CC} Only)	-0.5V to +7.0V
Supply Voltage to Ground Potential (Outputs & D/O Only)	-0.5V to +7.0V
DC Input Voltage	-0.5V to +7.0V
DC Output Current	120mA
Power Dissipation	1Watt

Note:

Stresses greater than those listed under MAXIMUM RATINGS may cause permanent damage to the device. This is a stress rating only and functional operation of the device at these or any other conditions above those indicated in the operational sections of this specification is not implied. Exposure to absolute maximum rating conditions for extended periods may affect reliability.

Recommended Operating Condition

Parameter	Description	Min.	Max.	Units
V _{CC}	Supply Voltage	4	5.5	V
V _{IH}	High-Level Input Voltage	2	—	V
V _{IL}	Low-Level Input Voltage	—	0.8	V
T _A	Operating Free-Air Temperature	-40	85	°C

DC Electrical Characteristics (Over the Operating Range, T_A = -40°C to +85°C, V_{CC} = 5V ±10%)

Parameters	Description	Test Conditions ⁽¹⁾	Min.	Typ ⁽²⁾	Max.	Units	
V _{IH}	Input HIGH Voltage	Guaranteed Logic HIGH Level	2.0	—	—	V	
V _{IL}	Input LOW Voltage	Guaranteed Logic LOW Level	-0.5	—	0.8	V	
I _I	Input Current	V _{CC} = Max., V _{IN} = V _{CC} or GND	—	—	±1	μA	
		V _{CC} = 0, V _{IN} = V _{CC}	—	—	10	μA	
V _{IK}	Clamp Diode Voltage	V _{CC} = Min., I _{IN} = -18mA	—	-0.7	-1.2	V	
I _{OS}	Short Circuit Current ⁽³⁾	A(B) = 0V, B(A) = V _{CC}	100	—	—	mA	
V _H	Input Hysteresis at Control Pins		—	150	—	mV	
r _{ON}	Switch On Resistance ⁽⁴⁾	V _{CC} = Min., V _{IN} = 0.0V, I _{ON} = 64mA	16292	—	5	7	Ω
			162292	20	28	40	
		V _{CC} = Min., V _{IN} = 2.4V, I _{ON} = 15mA	16292	—	—	12	Ω
			162292	20	35	48	

Capacitance (T_A = 25°C, f = 1 MHz)

Parameters ⁽⁵⁾	Description	Test Conditions	Max.	Units
C _{IN}	Input Capacitance	V _{IN} = 0V	6	pF
C _{OFF}	A/B Capacitance, Switch Off	V _{IN} = 0V	10	pF
C _{ON}	A/B Capacitance, Switch On	V _{IN} = 0V	20	pF

Notes:

- For Max. or Min. conditions, use appropriate value specified under Electrical Characteristics for the applicable device.
- Typical values are at V_{CC} = 5.0V, T_A = 25°C ambient and maximum loading.
- Not more than one output should be shorted at one time. Duration of the test should not exceed one second.
- Measured by the voltage drop between A and B pin at indicated current through the switch. ON resistance is determined by the lower of the voltages on the two (A,B) pins.
- This parameter is determined by device characterization but is not production tested.

Power Supply Characteristics

Parameters	Description	Test Conditions ⁽¹⁾ Min.		Typ ⁽²⁾	Max.	Units	
I _{CC}	Quiescent Power Supply Current	V _{CC} = MAX.	V _{IN} = GND or V _{CC}	—	0.1	3.0	μA
ΔI _{CC} ⁽³⁾	Supply Current for S0 @ TTL HIGH	V _{CC} = MAX.	V _{IN} = 3.4 V ⁽⁴⁾ Other Inputs at V _{CC} OR GND	—	—	2.5	mA
I _{CCD}	Supply Current for S0 per MHz ⁽⁵⁾ Toggling 50% Duty Cycle	V _{CC} = Max., A and B Pins Open		—	—	0.75	mA/ MHz

Notes:

1. For conditions shown as Max. or Min., use appropriate value specified under Electrical Characteristics for applicable device.
2. Typical values are at V_{CC} = 5.0V, +25°C ambient.
3. This is the increase in supply current for S0 at the specified TTL voltage level rather than V_{CC} or GND.
4. Per TTL driven input (V_{IN} = 3.4V, S0 only); A and B pins do not contribute to I_{CC}.
5. This current applies to the control inputs only and represent the current required to switch internal capacitance at the specified frequency. The A and B inputs generate no significant AC or DC currents as they transition. This parameter is not tested, but is guaranteed by design.

PI5C16292 Switching Characteristics over Operating Range

Parameters	Description	Conditions ⁽¹⁾	PI5C16292		Units
			Com.		
			Min	Max	
t _{PLH} t _{PHL}	Propagation Delay ^(2,3) xA1 to xBx, xBx to xA1	C _L = 50pF R _L = 500Ω R = 500Ω to 7V ⁽⁴⁾	—	0.25	ns
t _{PZH} t _{PZL}	Bus Enable time S to xA1 or xBx		1.5	6.5	ns
t _{PHZ} t _{PLZ}	Bus Disable time S to xA1 or xBx		1.5	7	ns
			1.5	8	
t _M	Make-before-break time ⁽²⁾		0	2	ns

PI5C162292 Switching Characteristics over Operating Range

Parameters	Description	Conditions ⁽¹⁾	PI5C162292		Units
			Com.		
			Min	Max	
t _{PLH} t _{PHL}	Propagation Delay ^(2,3) xA1 to xBx, xBx to xA1	C _L = 50pF R _L = 500Ω R = 500Ω to 7V ⁽⁴⁾	—	1.25	ns
t _{PZH} t _{PZL}	Bus Enable Time S to xA1 or xBx		1.5	6.5	ns
t _{PHZ} t _{PLZ}	Bus Disable Time S to xA1 or xBx		1.5	7	ns
			1.5	8	
t _M	Make-before-break time ⁽²⁾		0	2	ns

Notes:

1. See test circuit and waveforms.
2. This parameter is guaranteed but not tested.
3. The bus switch contributes no propagational delay other than the RC delay of the ON resistance of the switch and load capacitance. The time constant for the switch alone is of the order of 0.25ns for 50pF load. Since this time constant is much smaller than rise/fall times of typical driving signals, it adds very little propagational delay to the system. Propagational delay of the bus switch, when used in a system, is determined by the driving circuit on the driving side of the switch and its interaction with the load on the driven side.
4. Applies to t_{PLZ} and t_{PZL}.

56-Pin SSOP (300 Mil Wide) - Package Code: V

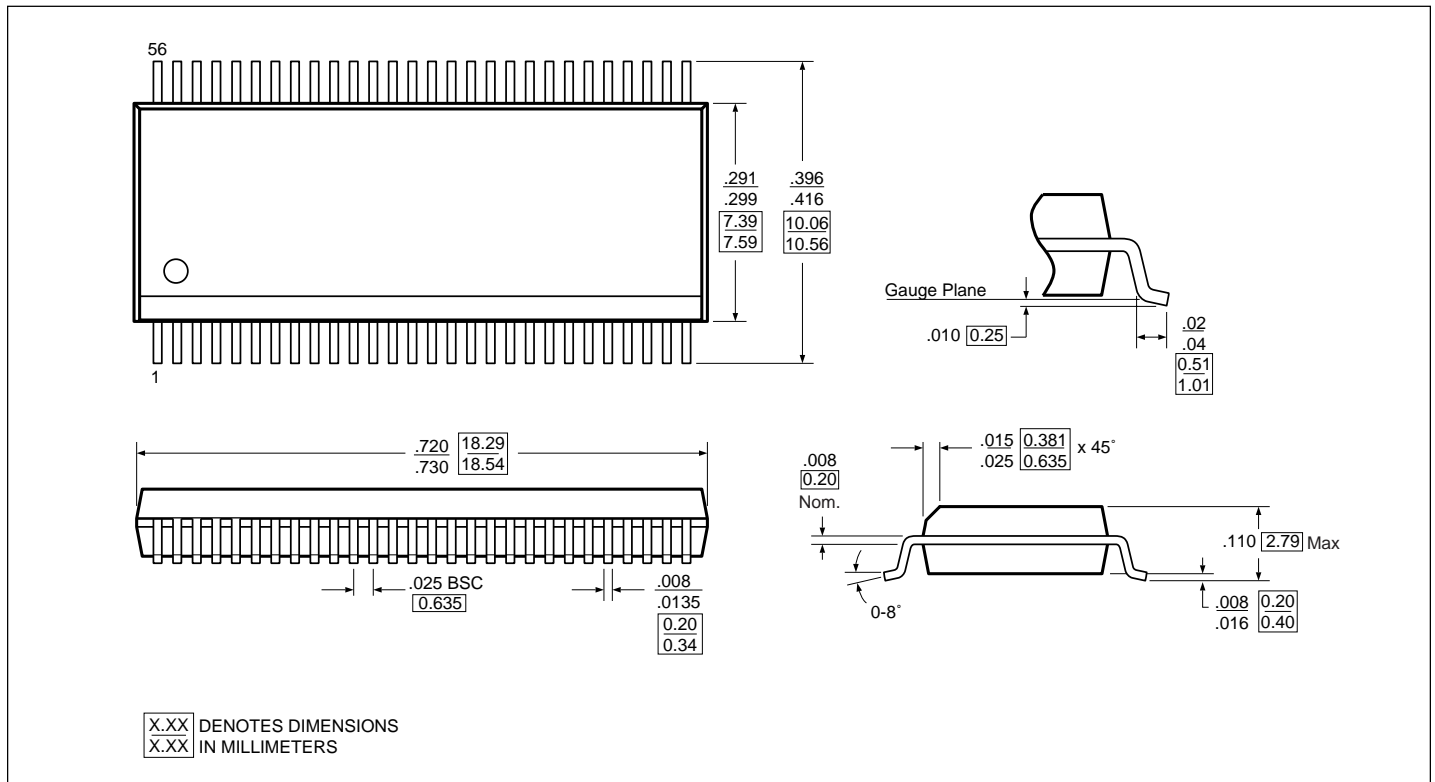

56-Pin TSSOP (240 Mil Wide) - Package Code: A

