

Features

- 2-stage operational amplifier for filter
- CDS to disable output during daytime
- Timings are fully adjustable with external RC components
- High level output for relay and triac drive with optical-coupler
- Built-in noise rejection circuit
- On-chip regulator
- Force on function
- Both AC and DC operating
- Operating voltage: 5V
- Few external components

General Description

The PT8A2620 is a CMOS mixed signal LSI designed for low cost applications using PIR as motion sensor.

The PIR sensor detects infrared power variations caused by motion of a human body and transfer to a voltage variation. If the PIR output voltage variation conforms to criteria, the lamp is turned on for an adjustable duration. CDS can enable or disable output with external voltage divider.

Applications

- Energy saving auto-switch in Garden, kitchen, bathroom, corridor, storage or yard

Ordering Information

Part Number	Package
PT8A2620P	16 - Pin PDIP
PT8A2620W	16 - Pin SOP

Block Diagram

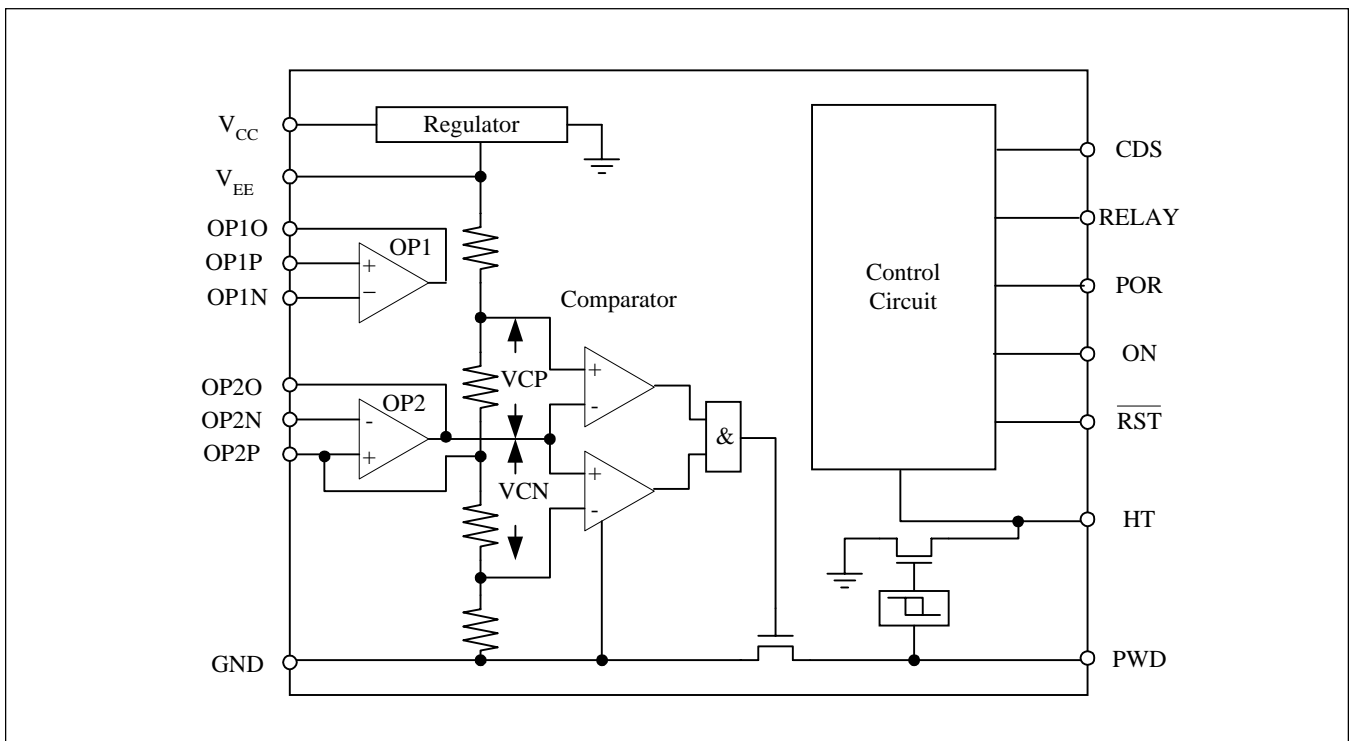

Pin Configuration

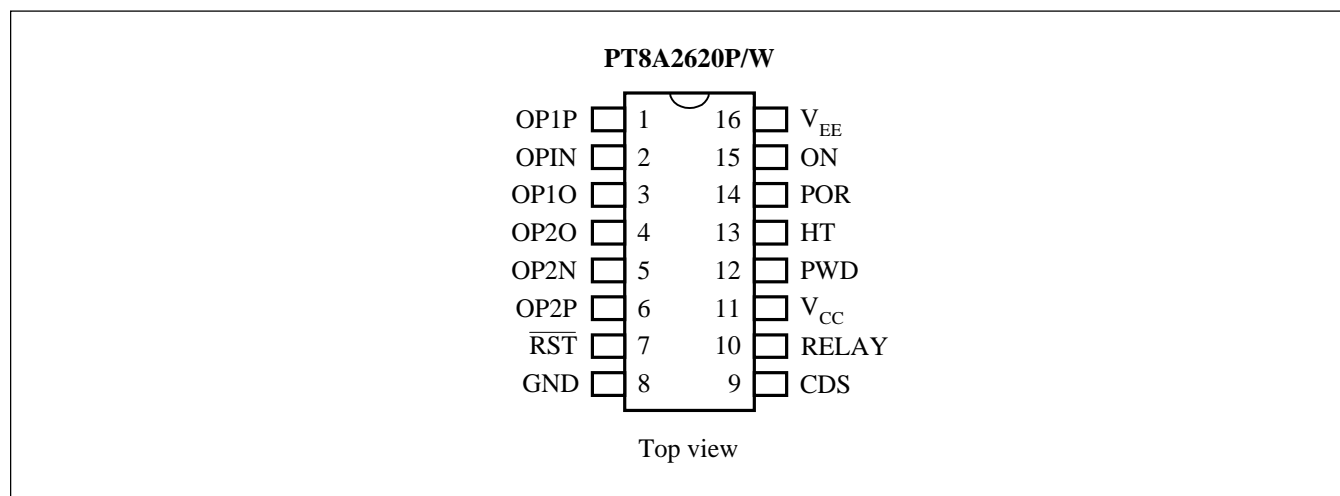

Pin Description

Pin	Name	Type	Description
1	OP1P	I	Non-inverted input of first operational amplifier, connected directly to source of PIR sensor
2	OP1N	I	Inverted input of first operational amplifier
3	OP1O	O	Output of first operational amplifier
4	OP2O	O	Output of second operational amplifier
5	OP2N	I	Inverted input of second operational amplifier
6	OP2P	I	Non-inverted input of second operational amplifier. Internal bias on 1.8V default.
7	$\overline{\text{RST}}$	I	Reset input, active low.
8	GND	Ground	Ground
9	CDS	I	Schmitt, connected to a CDS voltage divider for daytime/night auto-detection. Low input to this pin can disable PIR input. CDS should be connected to V _{CC} when not using this function.
10	RELAY	O	RELAY drive output through an external NPN transistor, active high. The output active duration is controlled by the HT pin
11	V _{CC}	Power	Power supply
12	PWD	I/O	Schmitt input/open drain output, pulse width detection*
13	HT	I/O	Schmitt input/open drain output, hold time, external RC to set output ON time duration. Use a VR to make variable ON time.
14	POR	I	Power on reset, reset the chip in about 40s after power on with an external RC.
15	ON	I	Schmitt, force on control input, active low.
16	V _{EE}	O	Internal voltage regulator output, 3.6V with respect to ground. Connected to the drain of PIR sensor

* An active motion must meet certain condition. The chip transfers motion to pulse width signal, so an active motion must meet a preset pulse width. Pulse width is adjustable by external RC.

Functional description

Pulse width detection (PWD) or Noise rejection circuit

Pulse width detection can be used to filter the noise in order to prevent error trigger from the system. The default criteria of the width must be more than 400ms which can be set with an external RC.

Hold time (HT)

Hold time, in other word, the output active duration, it can be set with an external RC. One various resistor can be used to changed the related output duration.

Force on function

The IC can force the controlled lamp to on state by turning off the power supply for a brief period of time. During this brief power interruption, the power to the IC must be maintained. Shown in the schematic, with ON input discharged to low while $\overline{\text{RST}}$ maintains at high, the lamp output can be set to on until a $\overline{\text{RST}}$ input is low (longer period of power down). This feature may cause not intended lamp on situation during brief power interruption. Tie ON to V_{CC} to disable this feature.

Force On Function

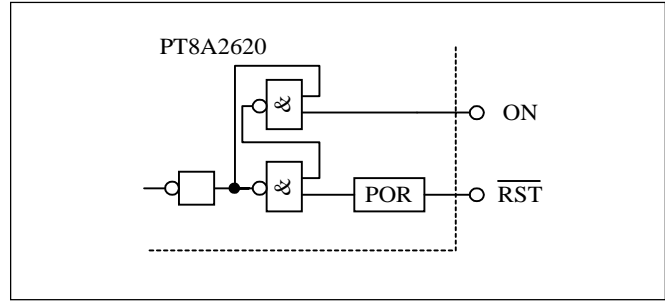

Power on Reset (POR)

The external PIR sensor requires a period of up to 40 seconds to stabilize, so a power on reset circuit is required to ensure proper operations. During this power on reset period, the lamp is on to indicate proper operation.

Retrigger

If another PIR signal is attained with valid duration, the circuit will be retriggered, and the hold time will be restarted from this time.

Trigger Timing

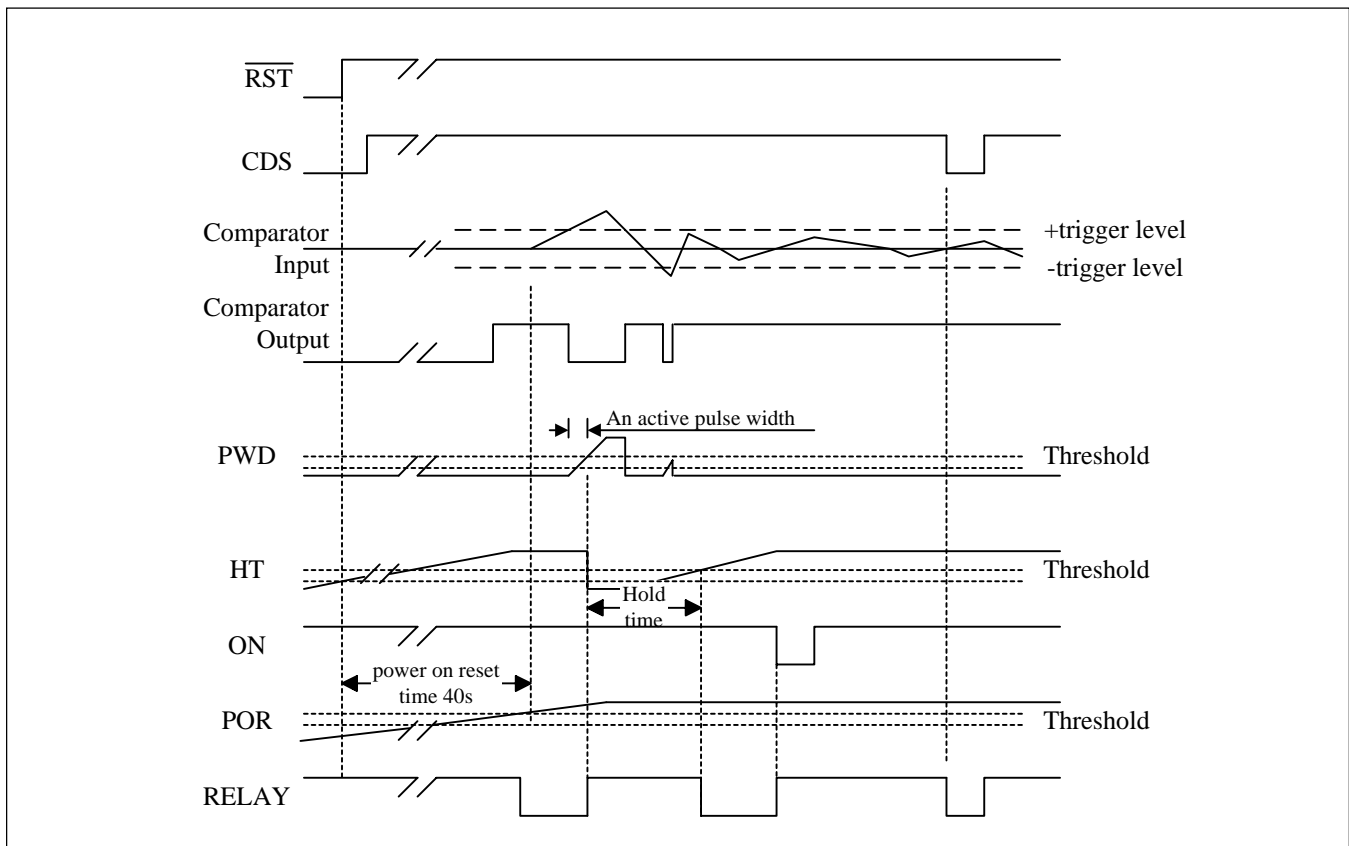

Maximum Ratings

(Above which the useful life may be impaired. For user guidelines, not tested)

Storage Temperature	-40°C to +125°C
Supply Voltage to Ground Potential (Inputs & V _{CC} Only)	-0.3 to +6.0V
Supply Voltage to Ground Potential (Outputs & D/O Only)	-0.3 to +6.0V
DC Input Voltage	-0.3 to +6.0V
DC Output Current	20mA
Power Dissipation	500mW

Note:

Stresses greater than those listed under MAXIMUM RATINGS may cause permanent damage to the device. This is a stress rating only and functional operation of the device at these or any other conditions above those indicated in the operational sections of this specification is not implied. Exposure to absolute maximum rating conditions for extended periods may affect reliability.

Recommended Operation Conditions

Sym	Description	Min	Typ	Max	Units
V _{CC}	Supply Voltage	4.75	5.0	6.0	V
T _A	Operation Temperature	-25	25	70	°C

DC Electrical Characteristics

Sym	Description	Test Conditions	Min	Typ	Max	Units
I _{IH}	Input high leakage current (POR, CDS, ON)	V _{IH} = 4.5V	-1	-	1	μA
	Input high leakage current (\overline{RST})		-6	-	-1	μA
I _{IL}	Input low leakage current (POR, CDS, ON)	V _{IL} = 0.5V	-1	-	1	μA
	Input low leakage current (\overline{RST})		-15	-	-8	μA
I _{OH}	OUTPUT Source Current (RELAY)	V _{OH} = 4.5V	-10	-	-	mA
I _{OL}	OUTPUT Sink Current (HT)	V _{OL} = 0.5V	30	-	-	mA
	OUTPUT Sink Current (PWD)		10	-	-	mA
	OUTPUT Sink Current (RELAY)		5	-	-	mA
V _{TH1}	"H" Transfer Voltage (POR, CDS, PWD, HT)	-	3.0	3.3	3.6	V
V _{TL1}	"L" Transfer Voltage (POR, CDS, PWD, HT)	-	1.4	1.7	2.0	V
V _{TH2}	"H" Transfer Voltage (ON)	-	2.7	3.0	3.3	V
V _{TL2}	"L" Transfer Voltage (ON)	-	1.6	1.9	2.2	V
V _{TH3}	"H" Transfer Voltage (\overline{RST})	-	2.8	3.1	3.4	V
V _{TL3}	"L" Transfer Voltage (\overline{RST})	-	1.4	1.7	2.0	V

Note: These specifications apply for V_{CC} = 5.0V and -25°C ≤ T_A ≤ 70°C, unless otherwise specified.

AC Electrical Characteristics

Voltage Regulator

Sym	Description	Test Conditions	Min	Typ	Max	Units
V_{EE}	Regulator Output Voltage	No load	3.2	3.6	4.0	V
V_{OP2P}	Noninverting input of OP2	No load	1.5	-	2.0	V
ΔV_O	Line Regulation	$4.5V \leq V_{CC} \leq 5.5V, I_L = 1mA$	-	-	100	mV
ΔV_{LDR}	Load Regulation	$V_{CC} = 5V, 0.5mA \leq I_L \leq 2mA$	-	-	30	mV
I_L	Regulator Output Current	$V_{CC} = 5V$	4	-	-	mA

Operational Amplifier and Window Comparator

Sym	Description	Test Conditions	Min	Typ	Max	Units
BW	3dB Bandwidth	-	10	-	-	kHz
V_{TH}	Windows Comparator Threshold	$V_{CC} = 5V$	1.9	2.05	2.2	V
V_{TL}		$V_{CC} = 5V$	1.4	1.55	1.7	V

Power Dissipation

Sym	Description	Test Conditions	Min	Typ	Max	Units
I_{CC}	Power Supply Current	$V_{CC} = 5V,$ other input pins = GND, all outputs float	-	-	200	μA

Application Circuit of PT8A2620

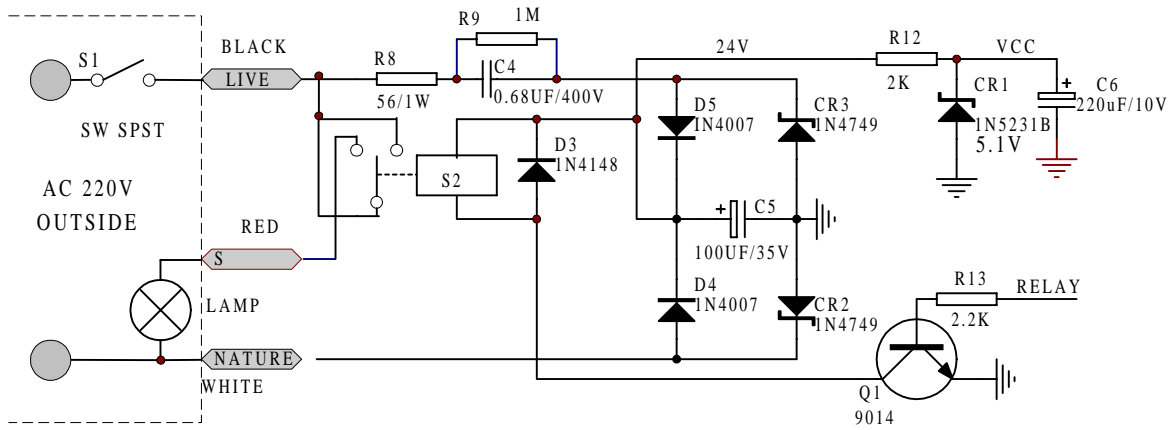

Turn S1 on/off once to enter chip into force on state.
 Exiting force on must power off a period

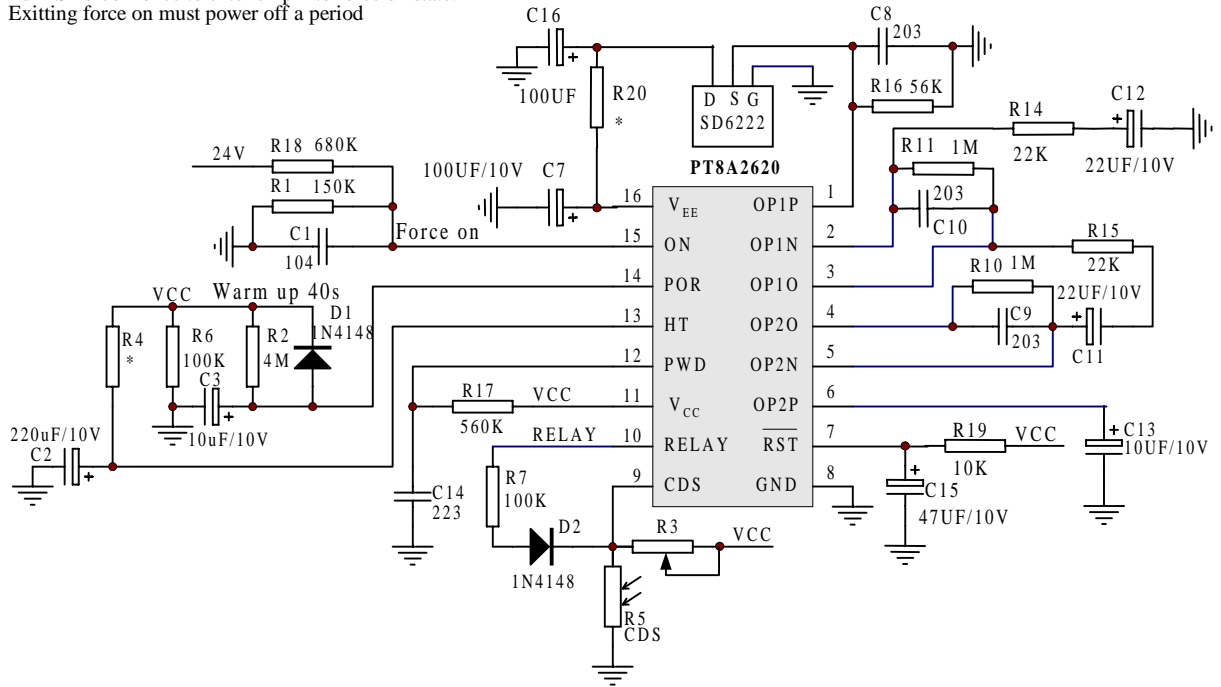

Notes

Pericom Technology Inc.

Email: support@pti.com.cn Web Site: www.pti.com.cn, www.pti-ic.com

China: No. 20 Building, 3/F, 481 Guiping Road, Shanghai, 200233, China
Tel: (86)-21-6485 0576 Fax: (86)-21-6485 2181

Asia Pacific: Unit 1517, 15/F, Chevalier Commercial Centre, 8 Wang Hoi Rd, Kowloon Bay, Hongkong
Tel: (852)-2243 3660 Fax: (852)- 2243 3667

U.S.A.: 2380 Bering Drive, San Jose, California 95131, USA
Tel: (1)-408-435 0800 Fax: (1)-408-435 1100

Pericom Technology Incorporation reserves the right to make changes to its products or specifications at any time, without notice, in order to improve design or performance and to supply the best possible product. Pericom Technology does not assume any responsibility for use of any circuitry described other than the circuitry embodied in Pericom Technology product. The company makes no representations that circuitry described herein is free from patent infringement or other rights, of Pericom Technology Incorporation.