

IS61C256AH

32K x 8 HIGH-SPEED CMOS STATIC RAM

MAY 1999

FEATURES

- High-speed access time: 10, 12, 15, 20, 25 ns
- Low active power: 400 mW (typical)
- Low standby power
 - 250 μ W (typical) CMOS standby
 - 55 mW (typical) TTL standby
- Fully static operation: no clock or refresh required
- TTL compatible inputs and outputs
- Single 5V power supply

DESCRIPTION

The *ISSI* IS61C256AH is a very high-speed, low power, 32,768 word by 8-bit static RAMs. They are fabricated using *ISSI*'s high-performance CMOS technology. This highly reliable process coupled with innovative circuit design techniques, yields access times as fast as 10 ns maximum.

When \overline{CE} is HIGH (deselected), the device assumes a standby mode at which the power dissipation can be reduced down to 250 μ W (typical) with CMOS input levels.

Easy memory expansion is provided by using an active LOW Chip Enable (\overline{CE}) input and an active LOW Output Enable (\overline{OE}) input. The active LOW Write Enable (\overline{WE}) controls both writing and reading of the memory.

The IS61C256AH is pin compatible with other 32K x 8 SRAMs and are available in 28-pin PDIP, SOJ, and TSOP (Type I) packages.

FUNCTIONAL BLOCK DIAGRAM

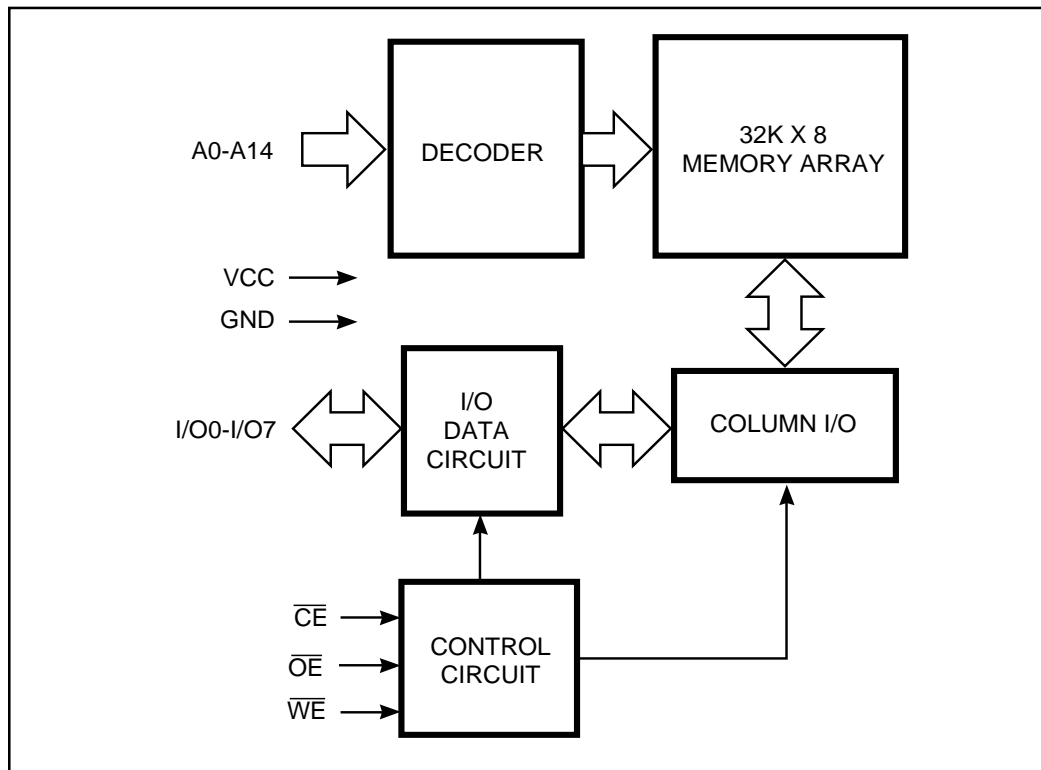

ISSI reserves the right to make changes to its products at any time without notice in order to improve design and supply the best possible product. We assume no responsibility for any errors which may appear in this publication. © Copyright 1999, Integrated Silicon Solution, Inc.

PIN CONFIGURATION

28-Pin DIP and SOJ

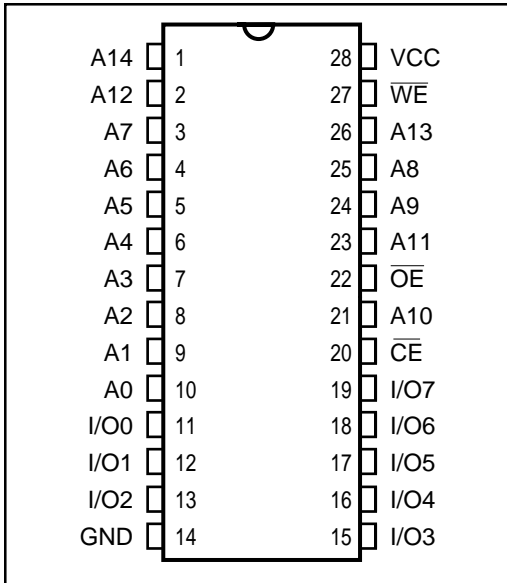

PIN CONFIGURATION

28-Pin TSOP

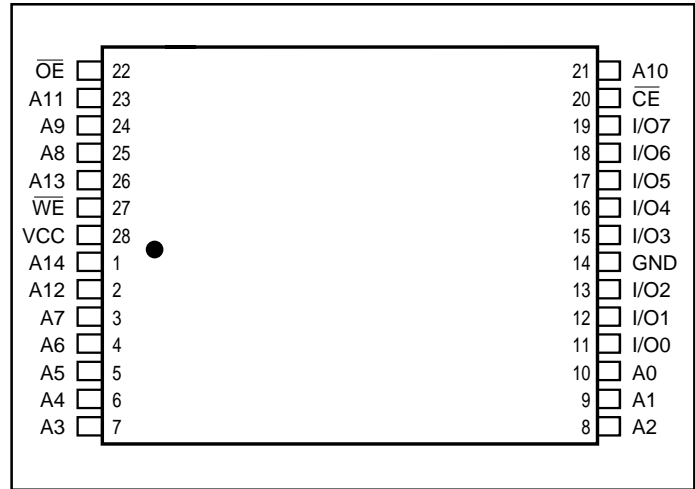

PIN DESCRIPTIONS

A0-A14	Address Inputs
\overline{CE}	Chip Enable Input
\overline{OE}	Output Enable Input
\overline{WE}	Write Enable Input
I/O0-I/O7	Bidirectional Ports
Vcc	Power
GND	Ground

TRUTH TABLE

Mode	\overline{WE}	\overline{CE}	\overline{OE}	I/O Operation	Vcc Current
Not Selected (Power-down)	X	H	X	High-Z	ISB1, ISB2
Output Disabled	H	L	H	High-Z	Icc
Read	H	L	L	DOUT	Icc
Write	L	L	X	DIN	Icc

ABSOLUTE MAXIMUM RATINGS⁽¹⁾

Symbol	Parameter	Value	Unit
V _{TERM}	Terminal Voltage with Respect to GND	-0.5 to +7.0	V
T _{BIAS}	Temperature Under Bias	-55 to +125	°C
T _{STG}	Storage Temperature	-65 to +150	°C
P _T	Power Dissipation	1.5	W
I _{OUT}	DC Output Current (LOW)	20	mA

Note:

1. Stress greater than those listed under ABSOLUTE MAXIMUM RATINGS may cause permanent damage to the device. This is a stress rating only and functional operation of the device at these or any other conditions above those indicated in the operational sections of this specification is not implied. Exposure to absolute maximum rating conditions for extended periods may affect reliability.

IS61C256AH

OPERATING RANGE

Range	Ambient Temperature	Speed	Vcc
Commercial	0°C to +70°C	-10, -12	5V ± 5%
		-15, -20, -25	5V ± 10%
Industrial	-40°C to +85°C	-12	5V ± 5%
		-15, -20, -25	5V ± 10%

DC ELECTRICAL CHARACTERISTICS (Over Operating Range)

Symbol	Parameter	Test Conditions	Min.	Max.	Unit	
V _{OH}	Output HIGH Voltage	V _{CC} = Min., I _{OH} = -4.0 mA	2.4	—	V	
V _{OL}	Output LOW Voltage	V _{CC} = Min., I _{OL} = 8.0 mA	—	0.4	V	
V _{IH}	Input HIGH Voltage		2.2	V _{CC} + 0.5	V	
V _{IL}	Input LOW Voltage ⁽¹⁾		-0.5	0.8	V	
I _{LI}	Input Leakage	GND ≤ V _{IN} ≤ V _{CC}	Com.	-5	5	μA
			Ind.	-10	10	
I _{LO}	Output Leakage	GND ≤ V _{OUT} ≤ V _{CC} , Outputs Disabled	Com.	-5	5	μA
			Ind.	-10	10	

Note:

1. V_{IL} = -3.0V for pulse width less than 10 ns.

POWER SUPPLY CHARACTERISTICS⁽¹⁾ (Over Operating Range)

Symbol	Parameter	Test Conditions		-10		-12		-15		-20		-25		Unit
				Min.	Max.	Min.	Max.	Min.	Max.	Min.	Max.	Min.	Max.	
I _{CC}	V _{CC} Dynamic Operating Supply Current	V _{CC} = Max., \overline{CE} = V _{IL} I _{OUT} = 0 mA, f = f _{MAX}	Com.	—	165	—	155	—	145	—	135	—	125	mA
			Ind.	—	—	—	165	—	155	—	145	—	135	
I _{SB1}	TTL Standby Current (TTL Inputs)	V _{CC} = Max., V _{IN} = V _{IH} or V _{IL} \overline{CE} ≥ V _{IH} , f = 0	Com.	—	25	—	25	—	25	—	25	—	25	mA
			Ind.	—	—	—	30	—	30	—	30	—	30	
I _{SB2}	CMOS Standby Current (CMOS Inputs)	V _{CC} = Max., \overline{CE} ≥ V _{CC} - 0.2V, V _{IN} ≥ V _{CC} - 0.2V, or V _{IN} ≤ 0.2V, f = 0	Com.	—	2	—	2	—	2	—	2	—	2	mA
			Ind.	—	—	—	10	—	10	—	10	—	10	

Note:

1. At f = f_{MAX}, address and data inputs are cycling at the maximum frequency, f = 0 means no input lines change.

CAPACITANCE^(1,2)

Symbol	Parameter	Conditions	Max.	Unit
C _{IN}	Input Capacitance	V _{IN} = 0V	8	pF
C _{OUT}	Output Capacitance	V _{OUT} = 0V	10	pF

Notes:

- Tested initially and after any design or process changes that may affect these parameters.
- Test conditions: T_A = 25°C, f = 1 MHz, V_{CC} = 5.0V.

READ CYCLE SWITCHING CHARACTERISTICS⁽¹⁾ (Over Operating Range)

Symbol	Parameter	-10		-12		-15		-20		-25		Unit
		Min.	Max.	Min.	Max.	Min.	Max.	Min.	Max.	Min.	Max.	
t _{RC}	Read Cycle Time	10	—	12	—	15	—	20	—	25	—	ns
t _{AA}	Address Access Time	—	10	—	12	—	15	—	20	—	25	ns
t _{OHA}	Output Hold Time	2	—	2	—	2	—	2	—	2	—	ns
t _{ACE}	$\overline{\text{CE}}$ Access Time	—	10	—	12	—	15	—	20	—	25	ns
t _{DOE}	$\overline{\text{OE}}$ Access Time	—	5	—	5	—	7	—	8	—	9	ns
t _{LZOE} ⁽²⁾	$\overline{\text{OE}}$ to Low-Z Output	0	—	0	—	0	—	0	—	0	—	ns
t _{HZOE} ⁽²⁾	$\overline{\text{OE}}$ to High-Z Output	—	5	—	6	—	7	—	9	—	10	ns
t _{LZCE} ⁽²⁾	$\overline{\text{CE}}$ to Low-Z Output	2	—	3	—	3	—	3	—	3	—	ns
t _{HZCE} ⁽²⁾	$\overline{\text{CE}}$ to High-Z Output	—	5	—	7	—	8	—	9	—	10	ns
t _{PU} ⁽³⁾	$\overline{\text{CE}}$ to Power-Up	0	—	0	—	0	—	0	—	0	—	ns
t _{PD} ⁽³⁾	$\overline{\text{CE}}$ to Power-Down	—	10	—	12	—	15	—	18	—	20	ns

Notes:

1. Test conditions assume signal transition times of 5 ns or less, timing reference levels of 1.5V, input pulse levels of 0 to 3.0V and output loading specified in Figure 1.
2. Tested with the load in Figure 2. Transition is measured ± 500 mV from steady-state voltage. Not 100% tested.
3. Not 100% tested.

AC TEST CONDITIONS

Parameter	Unit
Input Pulse Level	0V to 3.0V
Input Rise and Fall Times	3 ns
Input and Output Timing and Reference Levels	1.5V
Output Load	See Figures 1 and 2

AC TEST LOADS

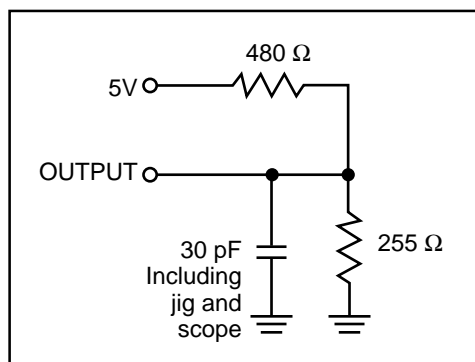

Figure 1

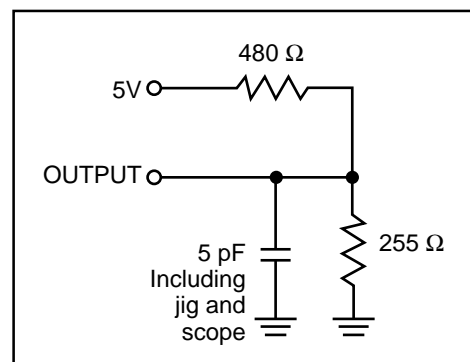
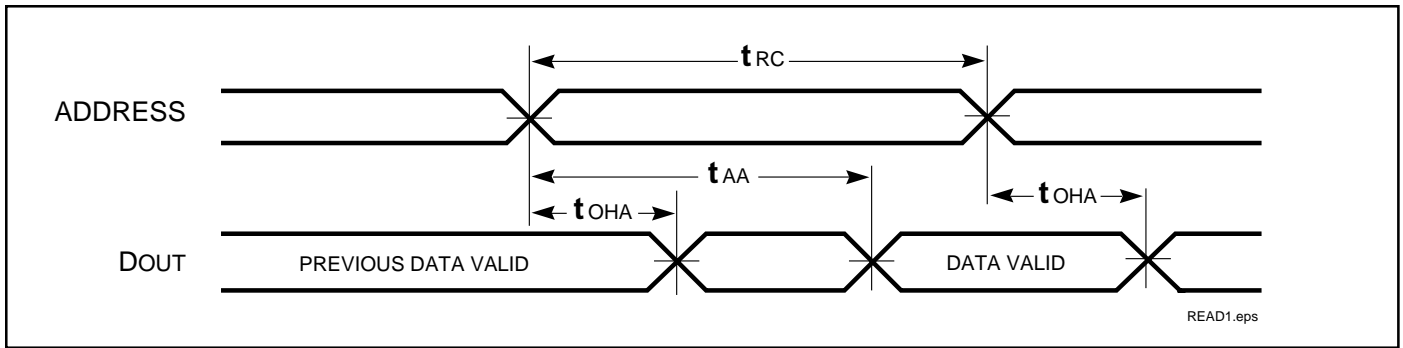

Figure 2

AC WAVEFORMS

READ CYCLE NO. 1^(1,2)



READ CYCLE NO. 2^(1,3)

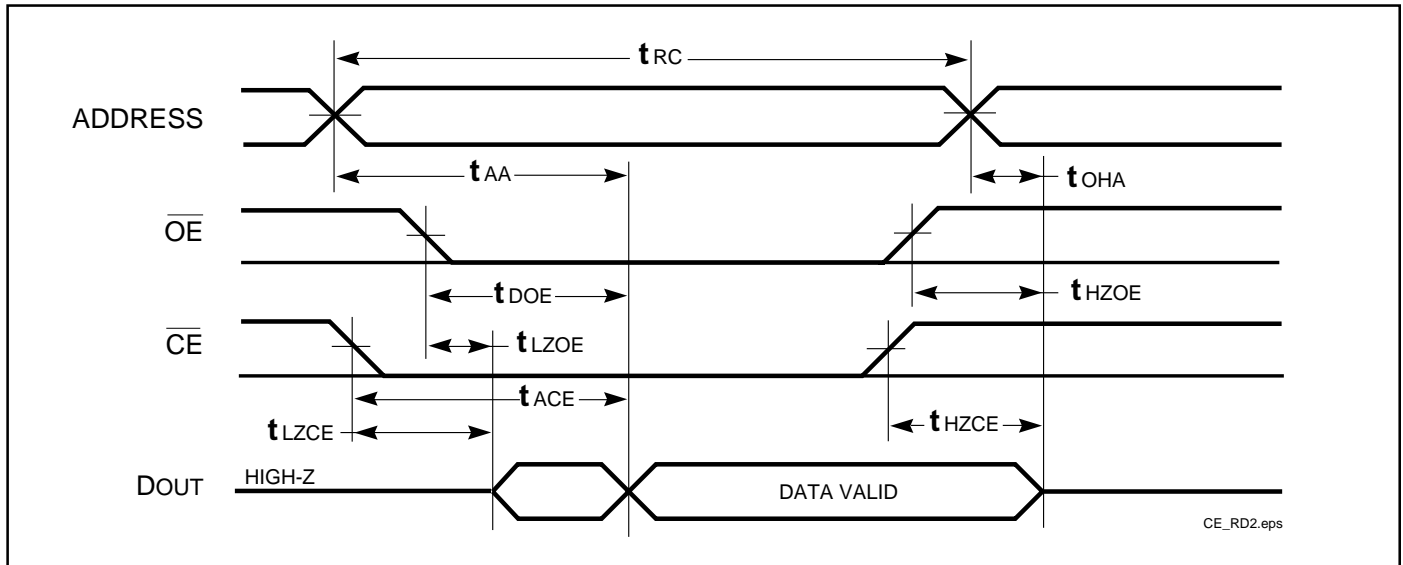

Notes:

1. \overline{WE} is HIGH for a Read Cycle.
2. The device is continuously selected. $\overline{OE}, \overline{CE} = V_{IL}$.
3. Address is valid prior to or coincident with \overline{CE} LOW transitions.

WRITE CYCLE SWITCHING CHARACTERISTICS^(1,3) (Over Operating Range)

Symbol	Parameter	-10		-12		-15		-20		-25		Unit
		Min.	Max.	Min.	Max.	Min.	Max.	Min.	Max.	Min.	Max.	
t _{WC}	Write Cycle Time	10	—	12	—	15	—	20	—	25	—	ns
t _{SCE}	\overline{CE} to Write End	9	—	10	—	10	—	13	—	15	—	ns
t _{AW}	Address Setup Time to Write End	9	—	10	—	12	—	15	—	20	—	ns
t _{HA}	Address Hold from Write End	0	—	0	—	0	—	0	—	0	—	ns
t _{SA}	Address Setup Time	0	—	0	—	0	—	0	—	0	—	ns
t _{PWE1}	\overline{WE} Pulse Width (\overline{OE} LOW)	8	—	8	—	10	—	13	—	15	—	ns
t _{PWE2}	\overline{WE} Pulse Width (\overline{OE} HIGH)	6.5	—	7	—	8	—	10	—	12	—	ns
t _{SD}	Data Setup to Write End	7	—	7	—	9	—	10	—	12	—	ns
t _{HD}	Data Hold from Write End	0	—	0	—	0	—	0	—	0	—	ns
t _{HZWE} ⁽²⁾	\overline{WE} LOW to High-Z Output	—	6	—	6	—	7	—	8	—	10	ns
t _{LZWE} ⁽²⁾	\overline{WE} HIGH to Low-Z Output	0	—	0	—	0	—	0	—	0	—	ns

Notes:

1. Test conditions assume signal transition times of 3 ns or less, timing reference levels of 1.5V, input pulse levels of 0 to 3.0V and output loading specified in Figure 1.
2. Tested with the load in Figure 2. Transition is measured ± 500 mV from steady-state voltage. Not 100% tested.
3. The internal write time is defined by the overlap of \overline{CE} LOW and \overline{WE} LOW. All signals must be in valid states to initiate a Write, but any one can go inactive to terminate the Write. The Data Input Setup and Hold timing are referenced to the rising or falling edge of the signal that terminates the write.

AC WAVEFORMS

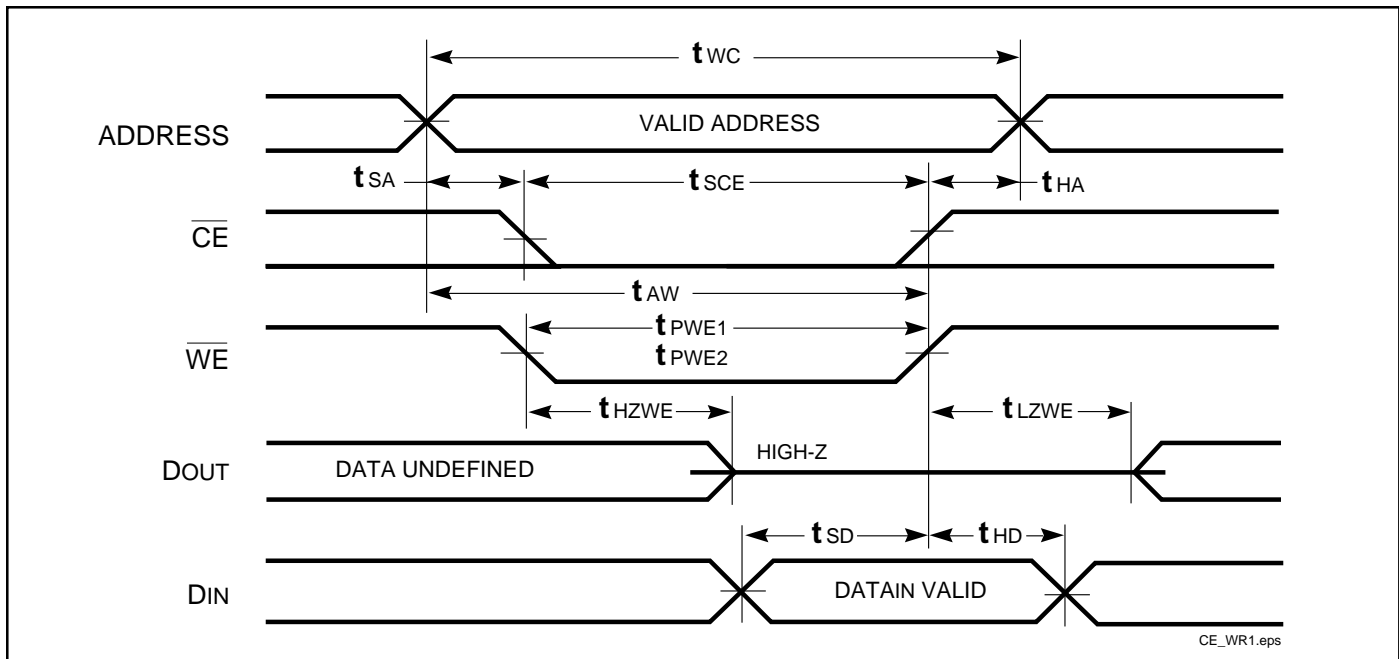
WRITE CYCLE NO. 1 (\overline{WE} Controlled)^(1,2)

WRITE CYCLE NO. 2 (\overline{OE} is HIGH During Write Cycle) ^(1,2)

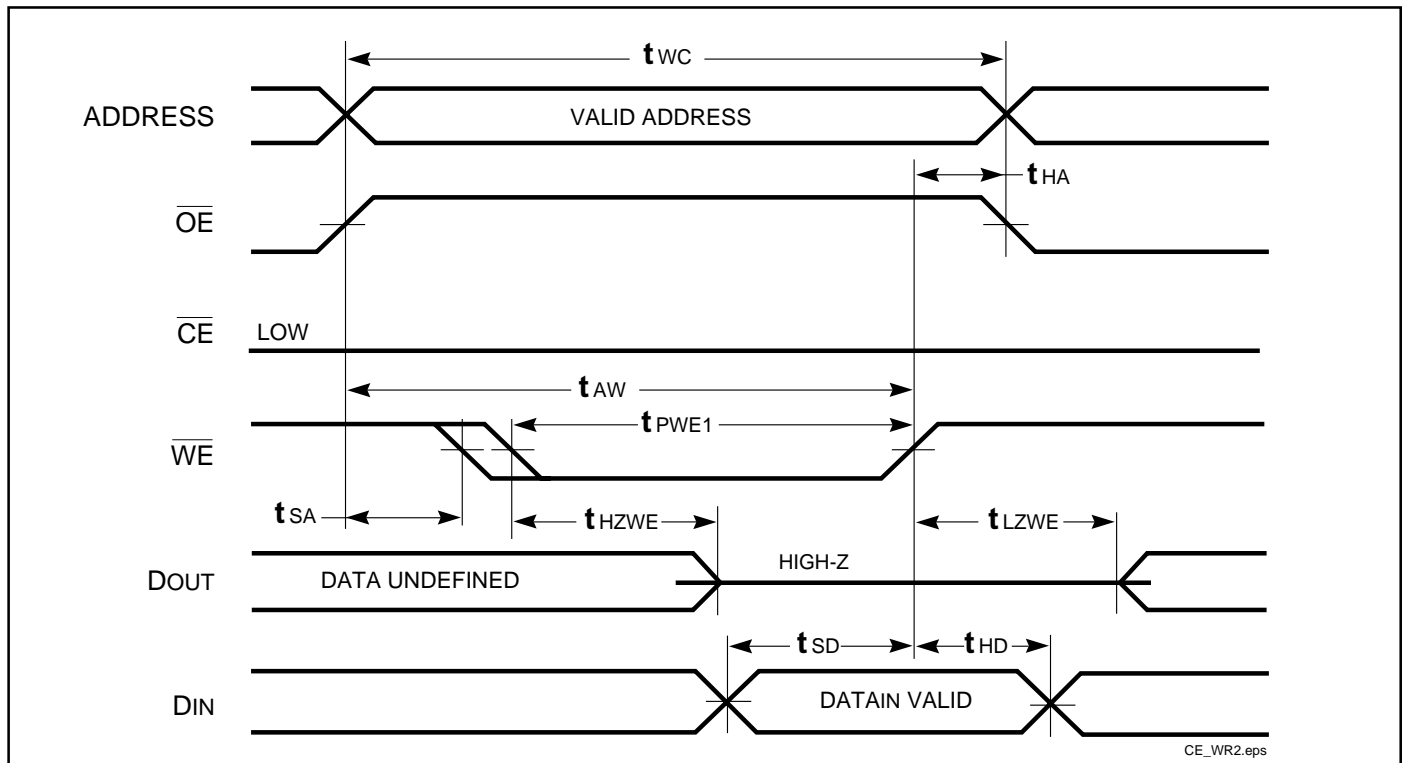

WRITE CYCLE NO. 3 (\overline{OE} is LOW During Write Cycle) ⁽¹⁾

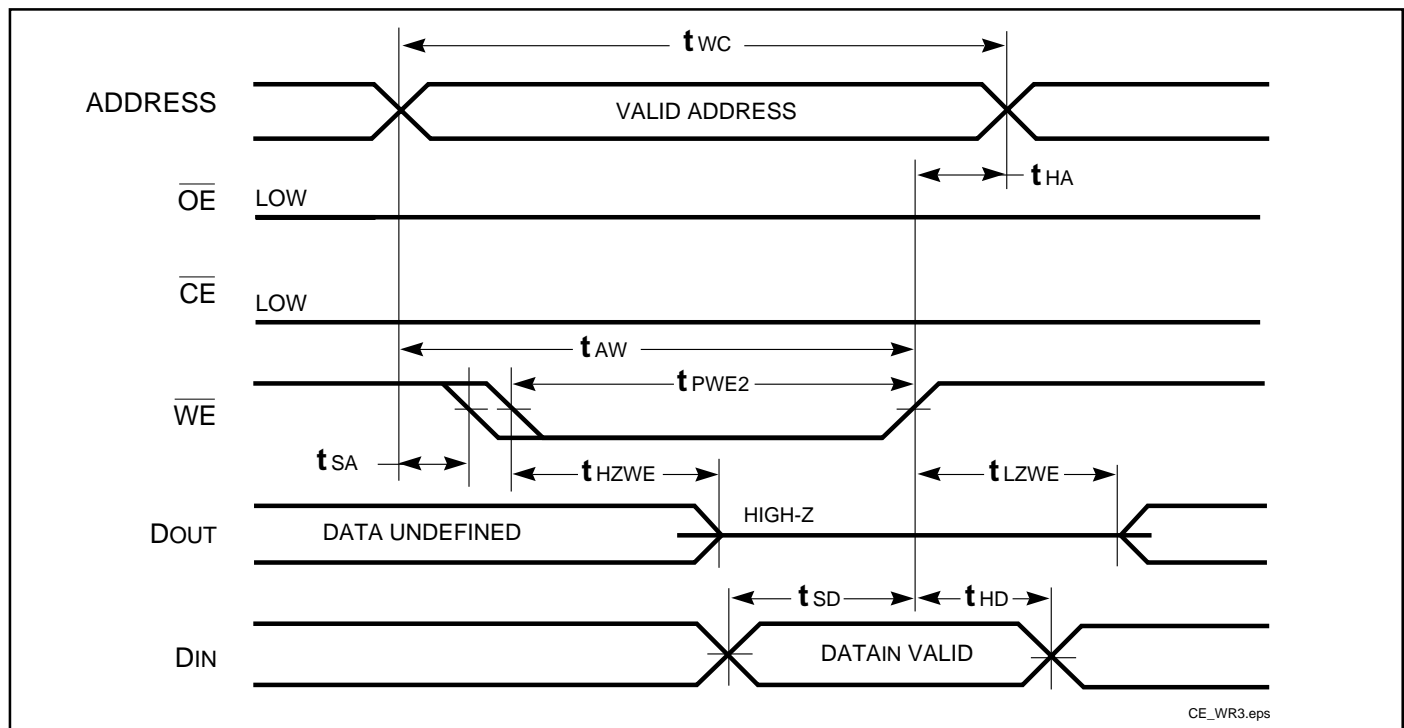

Notes:

1. The internal write time is defined by the overlap of \overline{CE} LOW and \overline{WE} LOW. All signals must be in valid states to initiate a Write, but any one can go inactive to terminate the Write. The Data Input Setup and Hold timing are referenced to the rising or falling edge of the signal that terminates the Write.
2. I/O will assume the High-Z state if $\overline{OE} \geq V_{IH}$.

ORDERING INFORMATION: IS61C256AH**Commercial Range: 0°C to +70°C**

Speed (ns)	Order Part Number	Package
10	IS61C256AH-10N	300-mil Plastic DIP
	IS61C256AH-10J	300-mil Plastic SOJ
	IS61C256AH-10T	TSOP (Type 1)
12	IS61C256AH-12N	300-mil Plastic DIP
	IS61C256AH-12J	300-mil Plastic SOJ
	IS61C256AH-12T	TSOP (Type 1)
15	IS61C256AH-15N	300-mil Plastic DIP
	IS61C256AH-15J	300-mil Plastic SOJ
	IS61C256AH-15T	TSOP (Type 1)
20	IS61C256AH-20N	300-mil Plastic DIP
	IS61C256AH-20J	300-mil Plastic SOJ
	IS61C256AH-20T	TSOP (Type 1)
25	IS61C256AH-25N	300-mil Plastic DIP
	IS61C256AH-25J	300-mil Plastic SOJ
	IS61C256AH-25T	TSOP (Type 1)

ORDERING INFORMATION: IS61C256AH**Industrial Range: -40°C to +85°C**

Speed (ns)	Order Part Number	Package
12	IS61C256AH-12NI	300-mil Plastic DIP
	IS61C256AH-12JI	300-mil Plastic SOJ
	IS61C256AH-12TI	TSOP (Type 1)
15	IS61C256AH-15NI	300-mil Plastic DIP
	IS61C256AH-15JI	300-mil Plastic SOJ
	IS61C256AH-15TI	TSOP (Type 1)
20	IS61C256AH-20NI	300-mil Plastic DIP
	IS61C256AH-20JI	300-mil Plastic SOJ
	IS61C256AH-20TI	TSOP (Type 1)
25	IS61C256AH-25NI	300-mil Plastic DIP
	IS61C256AH-25JI	300-mil Plastic SOJ
	IS61C256AH-25TI	TSOP (Type 1)

ISSI®

Integrated Silicon Solution, Inc.

2231 Lawson Lane

Santa Clara, CA 95054

Tel: 1-800-379-4774

Fax: (408) 588-0806

E-mail: sales@issi.com

www.issi.com