

4-bit REAL TIME CLOCK MODULE

# RTC-72421/72423

- Built-in crystal unit allows adjustment-free efficient operation.
- ALE input terminal available for 8048, 8051, and 8085 series.
- 12/24H clock switchover function and automatic leap year setting.
- Interrupt masking.
- 30 second adjustment function.
- Low current consumption and features a backup function.

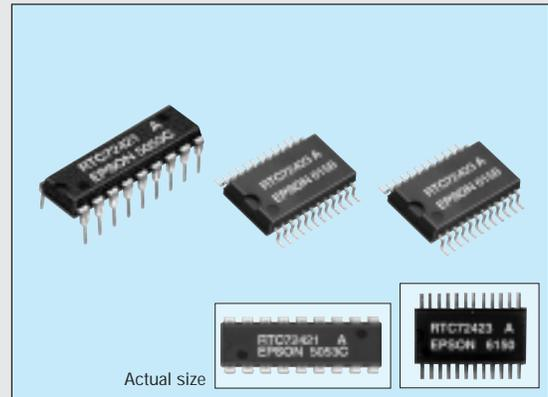

## Specifications (characteristics)

### Absolute Max. rating

Item	Symbol	Condition	Specifications	Unit
Power source voltage	V <sub>DD</sub>	T <sub>a</sub> =25°C	-0.3 to 7.0	V
Input and output voltage	V <sub>I/O</sub>	T <sub>a</sub> =25°C	GND -0.3 to V <sub>DD</sub> +0.3	V
Storage temperature	T <sub>STG</sub>	RTC-72421	-55 to +85	°C
		RTC-72423	-55 to +125	
Soldering condition	T <sub>SOL</sub>	RTC-72421	Under 260°C within 10 sec. (lead part) (package should be less than 150°C)	
		RTC-72423	Twice at under 260°C within 10 sec. or under 230°C within 3 min.	

### Operating range

Item	Symbol	Condition	Specifications	Unit
Operating voltage	V <sub>DD</sub>		4.5 to 5.5	V
Operating temperature	T <sub>OPR</sub>	RTC-72421	-10 to 70	°C
		RTC-72423	-40 to 85	
Data holding voltage	V <sub>DH</sub>		2.0 to 5.5	V
CSI data holding time	t <sub>CDR</sub>	Refer to the data holding timing	2.0 min.	µs
Operation restoring time	t <sub>R</sub>			

### Frequency characteristics and current consumption characteristics

Item	Symbol	Condition	Specifications	Unit	
Frequency tolerance	Δf/f <sub>0</sub>	T <sub>a</sub> =25°C V <sub>DD</sub> =5V	72421 A	±10	ppm
			72421 B	±50	
			72423 A	±20	
			72423	±50	
Frequency temperature characteristics		-10 to +70°C (25°C reference temperature)	+10/-120		
Aging	f <sub>a</sub>	V <sub>DD</sub> =5V, T <sub>a</sub> =25°C, first year	±5 max.	ppm/Y	
Shock resistance	S.R.	Three drops on a hard board from 75 cm or 3000G x 0.3ms x 1/2 sine wave x 3 directions	±10 max.	ppm	
Current consumption	I <sub>DD1</sub>	CS <sub>1</sub> =0V Exclude input/output current	V <sub>DD</sub> =5V 10 max.	µA	
	I <sub>DD2</sub>	V <sub>1</sub> =V <sub>DD</sub> /0V	V <sub>DD</sub> =2V 5 max.		

### Electrical characteristics

Item	Symbol	Condition	Min.	Typ.	Max.	Unit	Applicable terminal
"H" input voltage (1)	V <sub>IH1</sub>	—	2.2	—	—	V	All inputs other than CS <sub>1</sub>
"L" input voltage (1)	V <sub>IL1</sub>	—	—	—	0.8	V	
Input leak current (1)	I <sub>LK1</sub>	V <sub>1</sub> =V <sub>DD</sub> /0V	—	—	±1	µA	Input other than Do to D <sub>3</sub>
Input leak current (2)	I <sub>LK2</sub>		±10				
"L" output voltage (1)	V <sub>OL1</sub>	I <sub>OL</sub> =2.5mA	—	—	0.4	V	Do to D <sub>3</sub>
"H" output voltage	V <sub>OH</sub>	I <sub>OH</sub> =-400µA	2.4	—	—	V	
"L" output voltage (2)	V <sub>OL2</sub>	I <sub>OL</sub> =2.5mA	—	—	0.4	V	
Off leak current	I <sub>OFFLK</sub>	V <sub>1</sub> =V <sub>DD</sub> /0V	—	—	10	µA	STD.P
Input capacity	C <sub>1</sub>	Input frequency 1 MHz	—	10	—	pF	Input other than Do to D <sub>3</sub>
			—	20	—	pF	Do to D <sub>3</sub>
"H" input voltage (2)	V <sub>IH2</sub>	V <sub>DD</sub> =2 to 5.5V	4/5 V <sub>DD</sub>	—	—	V	CS <sub>1</sub>
"L" input voltage (2)	V <sub>IL2</sub>	V <sub>DD</sub> =2 to 5.5V	—	—	1/5 V <sub>DD</sub>	V	CS <sub>1</sub>

## Terminal connection

### RTC-72421

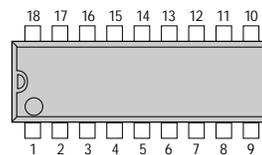

No.	72421	No.	72423
1	STD.P	1	STD.P
2	CS <sub>1</sub>	2	CS <sub>1</sub>
3	ALE	3	NC
4	A <sub>0</sub>	4	ALE
5	A <sub>1</sub>	5	A <sub>0</sub>
6	A <sub>2</sub>	6	NC
7	A <sub>3</sub>	7	A <sub>1</sub>
8	RD	8	NC
9	GND	9	A <sub>2</sub>
10	WR	10	A <sub>3</sub>
11	D <sub>2</sub>	11	RD
12	D <sub>1</sub>	12	GND
13	D <sub>1</sub>	13	WR
14	D <sub>2</sub>	14	D <sub>1</sub>
15	CS <sub>1</sub>	15	D <sub>2</sub>
16	(V <sub>DD</sub> )	16	D <sub>1</sub>
17	(V <sub>DD</sub> )	17	NC
18	V <sub>DD</sub>	18	NC
		19	D <sub>2</sub>
		20	CS <sub>1</sub>
		21	NC
		22	(V <sub>DD</sub> )
		23	(V <sub>DD</sub> )
		24	V <sub>DD</sub>

### RTC-72423

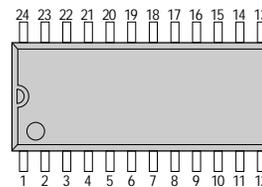

- (V<sub>DD</sub>) and V<sub>DD</sub> are to have the same level of voltage. Do not connect it to any external terminals.
- NC is not connected internally.

## External dimensions

(Unit: mm)

### RTC-72421

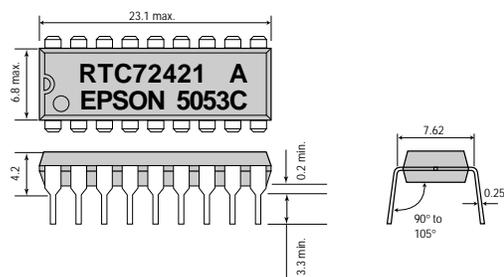

### RTC-72423

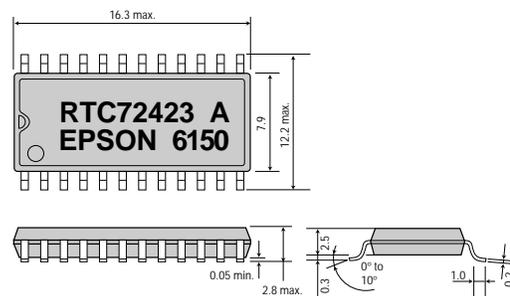

Register table

Address	A <sub>3</sub>	A <sub>2</sub>	A <sub>1</sub>	A <sub>0</sub>	Register	Data				Count Value	Remarks
						D <sub>3</sub>	D <sub>2</sub>	D <sub>1</sub>	D <sub>0</sub>		
0	0	0	0	0	S <sub>1</sub>	S <sub>8</sub>	S <sub>4</sub>	S <sub>2</sub>	S <sub>1</sub>	0 to 9	1-second digit register
1	0	0	0	1	S <sub>10</sub>	*	S <sub>40</sub>	S <sub>20</sub>	S <sub>10</sub>	0 to 5	10-second digit register
2	0	0	1	0	M <sub>1</sub>	m <sub>16</sub>	m <sub>4</sub>	m <sub>2</sub>	m <sub>1</sub>	0 to 9	1-minute digit register
3	0	0	1	1	M <sub>10</sub>	*	m <sub>40</sub>	m <sub>20</sub>	m <sub>10</sub>	0 to 5	10-minute digit register
4	0	1	0	0	H <sub>1</sub>	h <sub>8</sub>	h <sub>4</sub>	h <sub>2</sub>	h <sub>1</sub>	0 to 9	1-hour digit register
5	0	1	0	1	H <sub>10</sub>	*	PM/AM	h <sub>20</sub>	h <sub>10</sub>	0 to 2 or 0 to 1	PM/AM, 10-hours digit register
6	0	1	1	0	D <sub>1</sub>	d <sub>8</sub>	d <sub>4</sub>	d <sub>2</sub>	d <sub>1</sub>	0 to 9	1-day digit register
7	0	1	1	1	D <sub>10</sub>	*	*	d <sub>20</sub>	d <sub>10</sub>	0 to 3	10-day digit register
8	1	0	0	0	M <sub>0</sub>	m <sub>08</sub>	m <sub>04</sub>	m <sub>02</sub>	m <sub>01</sub>	0 to 9	1-month digit register
9	1	0	0	1	M <sub>0</sub>	*	*	*	m <sub>010</sub>	0 to 1	10-month digit register
A	1	0	1	0	Y <sub>1</sub>	y <sub>8</sub>	y <sub>4</sub>	y <sub>2</sub>	y <sub>1</sub>	0 to 9	1-year digit register
B	1	0	1	1	Y <sub>10</sub>	y <sub>80</sub>	y <sub>40</sub>	y <sub>20</sub>	y <sub>10</sub>	0 to 9	10-year digit register
C	1	1	0	0	W	*	W <sub>4</sub>	W <sub>2</sub>	W <sub>1</sub>	0 to 6	Week register
D	1	1	0	1	RegD	30 sec. ADJ.	IRQ FLAG	BUSY	HOLD		Control Register D
E	1	1	1	0	RegE	t <sub>1</sub>	t <sub>0</sub>	ITRPT/STND	MASK		Control Register E
F	1	1	1	1	RegF	TEST	24/12	STOP	REST		Control Register F

0="L" level, 1="H" level, REST = RESET ITRPT/STND=INTERRUPT/STANDARD

- Bit \* does not exist.
- Please mask AM/PM bit with 10's of hours operations.
- Busy is read only. IRQ can only. IRQ can only be set low ("0").
- | Data Bit | PM/AM | ITRPT/STND | 24/12 |
|----------|-------|------------|-------|
| 1        | PM    | ITRPT      | 24    |
| 0        | AM    | STND       | 12    |

5) TEST bit should be "0".

Switching characteristics (with ALE)

(Please connect ALE to V<sub>DD</sub> if the microprocessor does not have an ALE output.)

Item	Symbol	Condition	Min.	Max.	Unit
CS <sub>1</sub> setup time	t <sub>SU</sub> (CS1)		1000		ns
Address setup time before ALE	t <sub>SU</sub> (A-ALE)		50		
Address hold time after ALE	t <sub>H</sub> (ALE-A)		50		
ALE pulse width	t <sub>W</sub> (ALE)		80		
ALE setup time before WRITE	t <sub>SU</sub> (ALE-W)		0		
ALE setup time before READ	t <sub>SU</sub> (ALE-R)		0		
ALE setup time after WRITE	t <sub>SU</sub> (W-ALE)		50		
ALE setup time after READ	t <sub>SU</sub> (R-ALE)		50		
WRITE pulse width	t <sub>W</sub> (W)		120		
DATA delay time after READ	t <sub>PVZ</sub> (R-Q)	C <sub>L</sub> =150pF	—	120	
DATA Hold time after READ	t <sub>PVZ</sub> (R-Q)		0	70	
DATA setup time before WRITE	t <sub>SU</sub> (D-W)		80		
DATA hold time after WRITE	t <sub>H</sub> (W-D)		10		
CS <sub>1</sub> hold time	t <sub>H</sub> (CS1)		1000		
READ/WRITE recovery time	t <sub>REC</sub> (RAW)		200		

(V<sub>DD</sub> = 5V ± 0.5V)

Block diagram

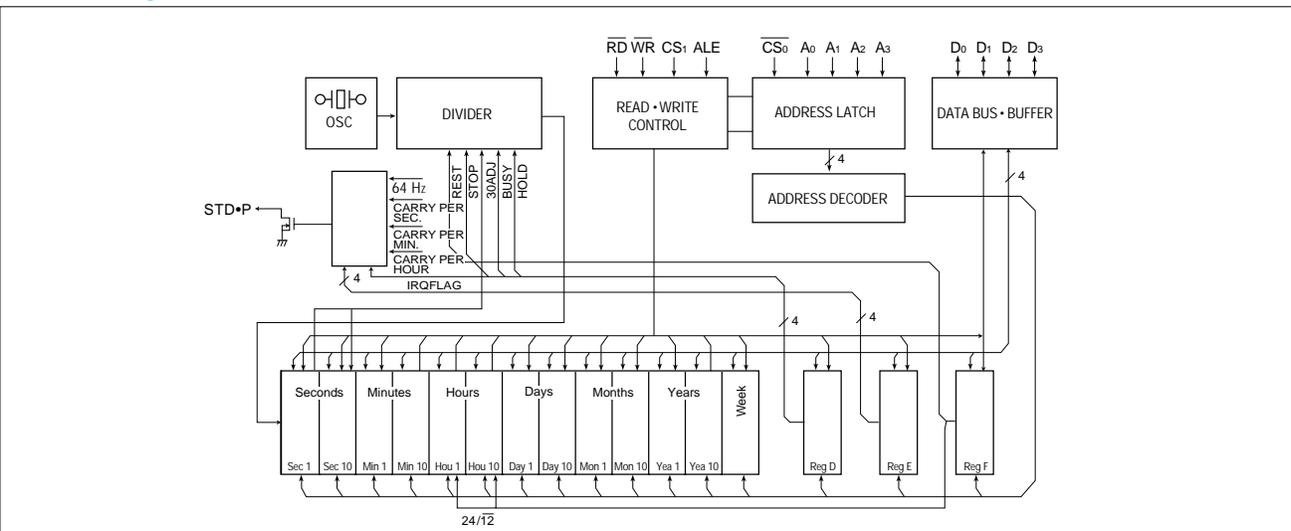

Write mode (with ALE)

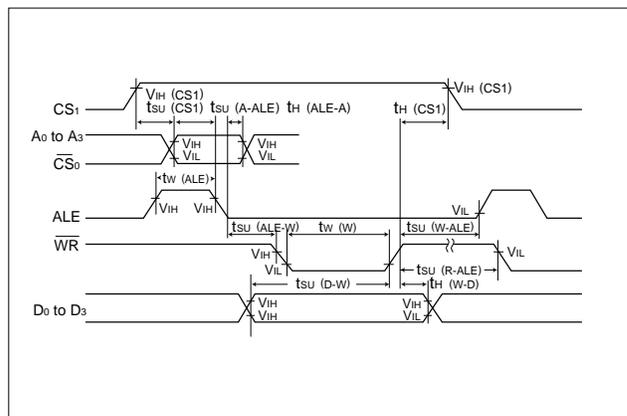

Read mode (with ALE)

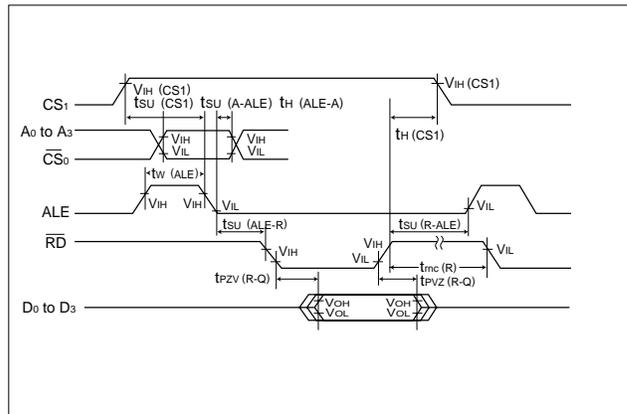

Data holding timing

