



T-75-07-07

UM91210/30

Tone/Pulse Dialer



Features

- 32-digit Redial Memory
- Tone/Pulse Switchable via slide switch
- Wide operating voltage: 2.0V to 5.5V
- Uses Inexpensive 3.58 MHz TV crystal
- Pin selectable Make/Break valid (1/2 or 2/3)
- Key-in tone output for valid key entry in Pulse mode

- (91230 C/D only)
- 630 millisecond flash time
- "T" key controlled switching from Pulse to Tone mode (91230 C/D only)
- 18-pin or 22-pin DIP
- With minimum tone duration 110 ms



General Description

The products in this series are Tone/Pulse switchable dialers with 32-digit redial memory. Switching from Pulse to DTMF mode can be accomplished either by using a slide switch or by depressing the **T** key.

The necessary dual-tone frequencies are all derived from a 3.58 MHz TV crystal, thus providing high accuracy and stability. The sinusoidal waveform for each individual tone is digitally synthesized on the chip. Waveforms thus generated have low total harmonic distortion (5% max.). A reference voltage is generated on the chip which is stable over the operating voltage and temperature range. It regulates the signal levels of the dual tones to meet telephone industry specifications.

CMOS technology is used in the production of these devices, resulting in low power requirements and high noise immunity. These devices can be easily interfaced with a variety of telephones, requiring only a minimum number of external components.

Ordering Information

| Part Number | Dialing Rate | Package |
|---------------|--------------|------------------|
| UM91210C/10CM | 10 pps | P-DIP 18L/SO 20L |
| UM91210D/10DM | 20 pps | P-DIP 18L/SO 20L |
| UM91230C/30CM | 10 pps | P-DIP 22L/SO 24L |
| UM91230D/30DM | 20 pps | P-DIP 22L/SO 24L |

Pin Configurations

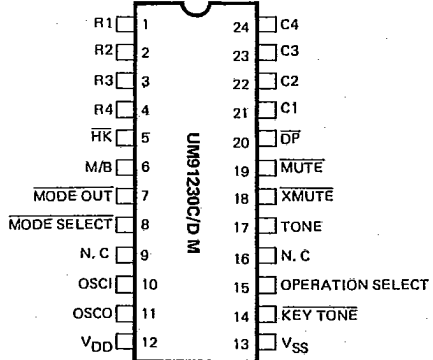
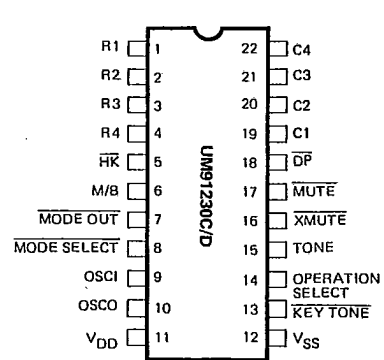

Keyboard Assignments

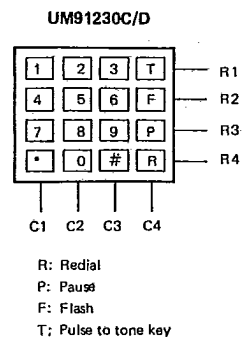



UM91210/30

T-75-07-07

Pin Configurations (Continued)

Keyboard Assignments (Continued)

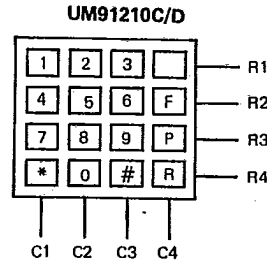
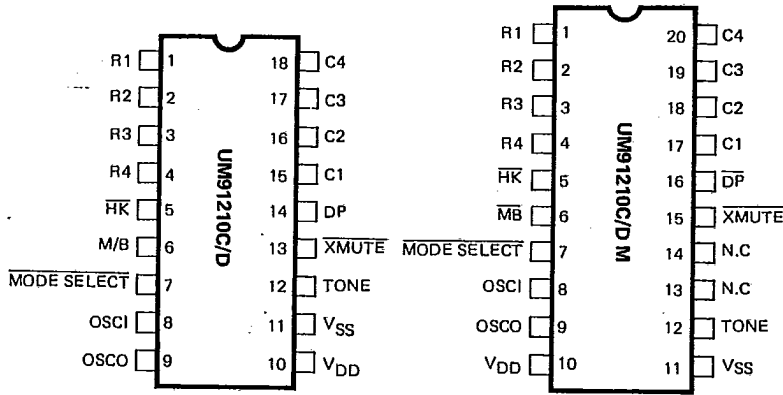

R: Redial
P: Pause
F: Flash

Block Diagram

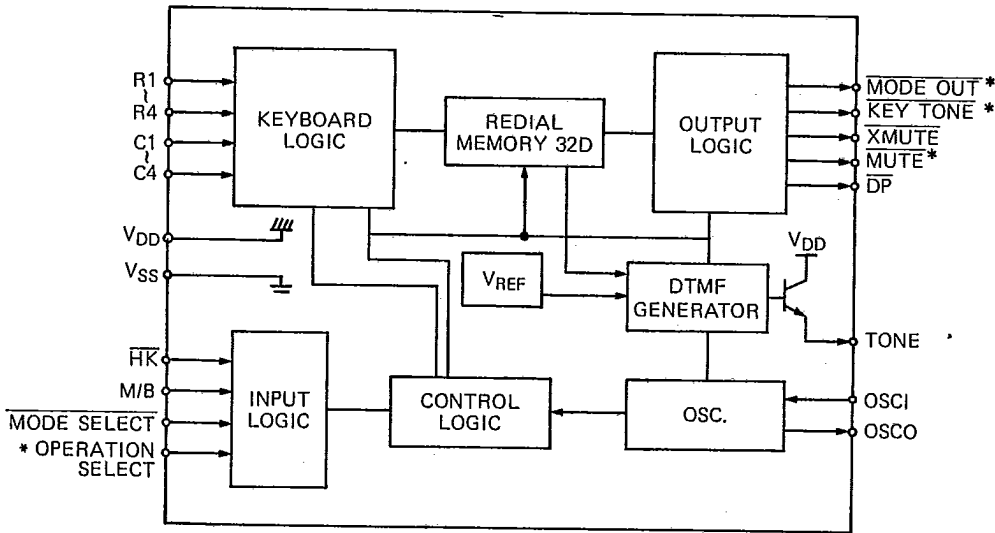

* : Bonding Option



UM91210/30

T-75-07-07

Absolute Maximum Ratings*

Power Supply Voltage.....-0.3V to +0.6V
 Input Voltage.....-0.3V to V_{DD}+0.3V
 Maximum Power Dissipation (at 25°C).....500mW
 Operating Temperature (T_{OP}).....-20°C to 70°C
 Storage Temperature (T_{STG}).....-55°C to +150°C

***Comments**

Stresses above those listed under "Absolute Maximum Ratings" may cause permanent damage to the device. These are stress ratings only. Functional operation of this device at these or any other conditions above those indicated in the operational sections of this specification is not implied and exposure to absolute maximum rating conditions for extended periods may affect device reliability.

DC Characteristics

(V_{DD} = 3.5V, V_{SS} = 0V, F_{OSC} = 3.579MHz and T_{OP} = 25°C unless otherwise specified.)

| Parameter | Symbol | Min. | Typ. | Max. | Unit | Conditions | Test Ckt. |
|---|------------------|------|----------------------|----------------------|-----------------|---|---|
| Operating Voltage | V _{DD} | 2.0 | | 5.5 | V | Pulse mode | A |
| | | 2.0 | | 5.5 | V | | |
| Memory Retention Voltage | V _{MR} | 1.0 | | | V | | |
| Memory Retention Current | I _{MR} | | 0.05 | 0.05 | μA | V _{DD} = 1.0V $\overline{HK} = V_{DD}$ All outputs unloaded | |
| Supply Operating Current | I _{DOP} | | 0.43 | 1 | mA | Pulse Mode | Oscillator running. All outputs unloaded |
| | I _{DOT} | | 0.70 | 2 | mA | DTMF Mode | |
| Standby Current | I _{SD} | | 15 | 50 | μA | V _{DD} = 2.5V $\overline{HK} = V_{SS}$ All outputs unloaded | A |
| Output Sink Current DP, MUTE, XMUTE | I _{OL1} | 1.7 | 5.0 | | mA | V _{OL} = 0.4V | B |
| | I _{OL2} | 0.5 | 1.5 | | mA | V _{OL} = 0.4V V _{DD} = 2.0V | |
| Input Voltage Range | V _{IH} | 0.8 | | 1 | V _{DD} | | |
| | V _{IL} | 0 | | 0.2 | V _{DD} | | |
| Row Input Current Col. Input Current | I _R | | 10 | | μA | V _{IN} = 0V | All outputs unloaded |
| | I _C | | 10 | | μA | V _{IN} = 0V | |
| Single Column Tone Output Amplitude | V _{OC} | 640 | 700 | 760 | mVp-p | R _{LOAD} = 10KΩ, V _{DD} = 2.5V | D |
| | | 640 | 700 | 760 | | R _{LOAD} = 10KΩ, V _{DD} = 5.5V | D |
| Single Row Tone Output Amplitude | V _{OR} | 510 | 560 | 610 | mVp-p | R _{LOAD} = 10KΩ, V _{DD} = 2.5V | D |
| | | 510 | 560 | 610 | | R _{LOAD} = 10KΩ, V _{DD} = 5.5V | D |
| Pre-emphasis | Twist | 1.7 | 2 | 2.3 | dB | | D |
| Valley of Single Tone | V _V | | V _{DD} -1.8 | V _{DD} -1.6 | V _{DD} | V _{DD} = 3.5V | D |
| Distortion | DIS | | 1 | 5 | % | * Note 1 | D |

Tone/Pulse Dialer

* Note 1: $DIS(\%) = \frac{100(V_1^2 + V_2^2 + \dots + V_n^2)^{1/2}}{(V_{IL}^2 + V_{IH}^2)^{1/2}}$

1. V₁...V_n are the intermodulation or harmonic frequencies in the 500 Hz to 3400 Hz band.
2. V_{IH} and V_{IL} are the individual frequency components of the DTMF signal.



UM91210/30

T-75-07-07

AC Characteristics

(V_{DD} = 3.5V, V_{SS} = 0V, F_{OSC} = 3.579545 MHz and T_{OP} = 25°C unless otherwise specified.)

| Parameter | Symbol | Conditions | Min. | Typ. | Max. | Unit |
|---------------------------------------|--------------------|-----------------------|-----------|------|------|------|
| PULSE | | | | | | |
| Make/Break Ratio | M/B | M/B = V _{DD} | | 1/2 | | % |
| | | M/B = V _{SS} | | 2/3 | | |
| Dial Pulse Rate | DR | UM91210C/UM91230C | | 9.7 | | pps |
| | | UM91210D/UM91230D | | 19.4 | | |
| Make Time | T _M | 10 pps | M/B = 1/2 | 33.3 | | ms |
| | | | M/B = 2/3 | 40.0 | | |
| | | 20 pps | M/B = 1/2 | 16.7 | | |
| | | | M/B = 2/3 | 20.0 | | |
| Break Time | T _B | 10 pps | M/B = 1/2 | 66.7 | | ms |
| | | | M/B = 2/3 | 60 | | |
| | | 20 pps | M/B = 1/2 | 33.3 | | |
| | | | M/B = 2/3 | 30 | | |
| Interdigit Pause Time | T _{IDP} | 10 pps | M/B = 1/2 | 876 | | ms |
| | | | M/B = 2/3 | 870 | | |
| | | 20 pps | M/B = 1/2 | 893 | | |
| | | | M/B = 2/3 | 890 | | |
| Predigit Pause | T _{PDP} | 10 pps | M/B = 1/2 | 19.5 | | ms |
| | | | M/B = 2/3 | 19.5 | | |
| | | 20 pps | M/B = 1/2 | 19.5 | | |
| | | | M/B = 2/3 | 19.5 | | |
| X _{MUTE} MUTE Delay Time | T _{MDP} | 10 pps | M/B = 1/2 | 850 | | ms |
| | | | M/B = 2/3 | 850 | | |
| | | 20 pps | M/B = 1/2 | 850 | | |
| | | | M/B = 2/3 | 850 | | |
| TONE | | | | | | |
| Minimum Tone Duration | T _{MFD} | | | 110 | | ms |
| Minimum Tone Interdigit Pause | T _{TIDP} | | | 110 | | ms |
| Tone Output Predigit Pause | T _{TPDP} | | | 0 | | ms |
| X _{MUTE} Delay Time | T _{MDT} | | | 110 | | ms |
| Auto Pause Time | T _{AP} | | | 3.6 | | s |
| Flash Time | T _F | | | 630 | | ms |
| Oscillator Startup Time | T _{START} | | | 10 | | ms |
| X _{MUTE} , MUTE Startup Time | T _{MS} | | | 15 | | ms |



UM91210/30

T-75-07-07

AC Characteristics (Continued)

| Parameter | Symbol | Condition | Min. | Typ. | Max. | Unit |
|---------------------------|----------------------|-----------|------|------|------|------|
| KEY-IN | | | | | | |
| Keypad Debounce Time | T _{KD} | | | 23 | | ms |
| Key Scan Frequency | F _{KS} | | | 445 | | Hz |
| KEY-IN TONE | | | | | | |
| Key-in Tone Duration Time | T _{KTD} | | | 23 | | ms |
| Key-in Tone Frequency | F _{KT} | | | 18 | | KHz |
| Key-in Tone Startup Time | T _{KTSTART} | | | 15 | | ms |

Tone/Pulse Dialer

| Row/Column | Condition | Spec. | Actual | Error(%) | Unit |
|------------|-----------------|-------|---------|----------|------|
| R1 | Fosc = 3.579MHz | 697 | 699.1 | +0.31 | Hz |
| R2 | | 770 | 766.2 | -0.49 | Hz |
| R3 | | 852 | 847.4 | -0.54 | Hz |
| R4 | | 941 | 948.0 | +0.74 | Hz |
| C1 | | 1,209 | 1,215.9 | +0.57 | Hz |
| C2 | | 1,336 | 1,331.7 | -0.32 | Hz |
| C3 | | 1,477 | 1,471.9 | -0.35 | Hz |

Pin Description

| Pin | | Designation | Description |
|-------|-------|-------------|---|
| 91210 | 91230 | | |
| 1 | 1 | R1 | Input Keys. These pins serve as an interface to an XY matrix keyboard. C1 through C4 and R1 through R4 are set to low at On Hook (\overline{HK} =high). C1 through C4 are set to low and R1 through R4 are set to high at Off Hook (\overline{HK} =low), which enables the key-in operation. The Oscillator starts running when a keypress is detected. Scanning signals are presented at both column and row input signals (Typ: 445 Hz) until the input key is released. Key-in is compatible with standard 2-of-8 form or single-contact keyboards. Debouncing is provided to avoid false entry (Typ.: 23 ms). |
| 2 | 2 | R2 | |
| 3 | 3 | R3 | |
| 4 | 4 | R4 | |
| 15 | 19 | C1 | |
| 16 | 20 | C2 | |
| 17 | 21 | C3 | |
| 18 | 22 | C4 | |
| 5 | 5 | HK | Hook Switch Input. This input detects the state of the hook switch contact. $\overline{HK} = V_{DD}$: On-hook, chip unactivated $\overline{HK} = V_{SS}$: Off-hook, chip active |
| 6 | 6 | M/B | Make/Break Ratio Select Input, This input allows selection of the Make/Break ratio (33.3:66.7/40:60) $M/B = V_{DD}$: 33.3/66.6 $M/B = V_{SS}$: 40/60 |



UM91210/30

T-75-07-07

Pin Description (Continued)

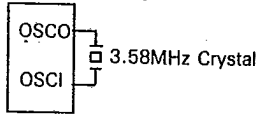
| Pin | | Designation | Description | | | | | | | | | | | | | | | | | | | | | |
|------------------|---------------------------------|------------------|---|---|---------------------------------|--------------|----------------------|-------|-----|-----|-------|------------------------------|---|-----|------|-----|-----|-----|-------|---|---|-----|------|-----|
| 91210 | 91230 | | | | | | | | | | | | | | | | | | | | | | | |
| | 7 | MODE OUT | Mode Output. This output indicates whether the chip is operating in Pulse or Tone mode. Pulse/Tone modes correspond to the OFF/ON states (N-channel open drain). Mode state is controlled by the Operation Select, MODE SELECT, and $\overline{\text{T}}$ key inputs. | | | | | | | | | | | | | | | | | | | | | |
| 7 | 8 | MODE SELECT | Mode Select Input. This input allows the selection of Pulse mode or DTMF mode. $\overline{\text{MODE SELECT}} = V_{DD}$: pulse mode operation $\overline{\text{MODE SELECT}} = V_{SS}$: tone mode operation | | | | | | | | | | | | | | | | | | | | | |
| 8 9 | 9 10 | Osci OscO | Oscillator Input/Output. These pins connect an external 3.58 MHz crystal to the UM91210/UM91230. Oscillation starts when the chip encounters the Off-Hook condition and is sustained until all Pulse or DTMF signals are completed.  | | | | | | | | | | | | | | | | | | | | | |
| 10 11 | 11 12 | VDD VSS | Power. These pins are the positive and negative power supply inputs. This device is designed to operate at 2.0V to 5.5V. | | | | | | | | | | | | | | | | | | | | | |
| | 13 | KEY TONE | Key-in Tone Output. The key-in tone signal is provided for all key entries in the Pulse mode, except for the $\overline{\text{T}}$ key. No KEY TONE signal is generated in the DTMF mode. F_{KT} : 1.8 KHz, T_{KT} : 23 ms, (N-channel open drain). | | | | | | | | | | | | | | | | | | | | | |
| | 14 | OPERATION SELECT | Operation Select Input. The operating mode can be switched from Pulse to DTMF by this input, whether the entry is made by the $\overline{\text{T}}$ key or by the $\overline{\text{MODE SELECT}}$ input. (See Table 8-1) Table 8-1 <table border="1" data-bbox="479 1218 1128 1585"> <thead> <tr> <th>Operation Select</th> <th>$\overline{\text{MODE SELECT}}$</th> <th>Initial Mode</th> <th>Switching Entry Mode</th> <th>Notes</th> </tr> </thead> <tbody> <tr> <td rowspan="2">VDD</td> <td>VDD</td> <td>Pulse</td> <td>$\overline{\text{T}}$ key-in</td> <td rowspan="2">$\overline{\text{MODE SELECT}}$ defines only initial mode after going Off Hook and is latched at first key entry.</td> </tr> <tr> <td>VSS</td> <td>Tone</td> <td>N/A</td> </tr> <tr> <td rowspan="2">VSS</td> <td>VDD</td> <td>Pulse</td> <td>$\overline{\text{MODE SELECT}}$ Input = VSS</td> <td rowspan="2">$\overline{\text{T}}$ key is disabled under this condition.</td> </tr> <tr> <td>VSS</td> <td>Tone</td> <td>N/A</td> </tr> </tbody> </table> | Operation Select | $\overline{\text{MODE SELECT}}$ | Initial Mode | Switching Entry Mode | Notes | VDD | VDD | Pulse | $\overline{\text{T}}$ key-in | $\overline{\text{MODE SELECT}}$ defines only initial mode after going Off Hook and is latched at first key entry. | VSS | Tone | N/A | VSS | VDD | Pulse | $\overline{\text{MODE SELECT}}$ Input = VSS | $\overline{\text{T}}$ key is disabled under this condition. | VSS | Tone | N/A |
| Operation Select | $\overline{\text{MODE SELECT}}$ | Initial Mode | Switching Entry Mode | Notes | | | | | | | | | | | | | | | | | | | | |
| VDD | VDD | Pulse | $\overline{\text{T}}$ key-in | $\overline{\text{MODE SELECT}}$ defines only initial mode after going Off Hook and is latched at first key entry. | | | | | | | | | | | | | | | | | | | | |
| | VSS | Tone | N/A | | | | | | | | | | | | | | | | | | | | | |
| VSS | VDD | Pulse | $\overline{\text{MODE SELECT}}$ Input = VSS | $\overline{\text{T}}$ key is disabled under this condition. | | | | | | | | | | | | | | | | | | | | |
| | VSS | Tone | N/A | | | | | | | | | | | | | | | | | | | | | |
| 12 | 15 | TONE | DTMF Signal (Output) When a valid keypress is detected in DTMF mode, appropriate low group and high group frequencies are generated which hybridize the Dual Tone output. Tone out is in the Off state in pulse mode. | | | | | | | | | | | | | | | | | | | | | |



UM91210/30

T-75-07-07

Pin Description (Continued)

| Pin | | Designation | Description | | | | | | |
|-----------------|--|-------------|---|----|--------------|-----------------|-----|-----------------|--|
| 91210 | 91230 | | | | | | | | |
| 13 | 16 | XMUTE | Xmute (Output) N-channel open drain. <table border="1" style="margin-left: 20px;"> <tr> <td>HK</td> <td>XMUTE OUTPUT</td> </tr> <tr> <td>V_{DD}</td> <td>OFF</td> </tr> <tr> <td>V_{SS}</td> <td>Normally Off On during Pulse and DTMF dialing.</td> </tr> </table> | HK | XMUTE OUTPUT | V _{DD} | OFF | V _{SS} | Normally Off On during Pulse and DTMF dialing. |
| HK | XMUTE OUTPUT | | | | | | | | |
| V _{DD} | OFF | | | | | | | | |
| V _{SS} | Normally Off On during Pulse and DTMF dialing. | | | | | | | | |
| | 17 | MUTE | Mute (Output) N-channel open drain. <table border="1" style="margin-left: 20px;"> <tr> <td>HK</td> <td>MUTE OUTPUT</td> </tr> <tr> <td>V_{DD}</td> <td>OFF</td> </tr> <tr> <td>V_{SS}</td> <td>Normally Off in DTMF mode. On during Pulse dialing.</td> </tr> </table> | HK | MUTE OUTPUT | V _{DD} | OFF | V _{SS} | Normally Off in DTMF mode. On during Pulse dialing. |
| HK | MUTE OUTPUT | | | | | | | | |
| V _{DD} | OFF | | | | | | | | |
| V _{SS} | Normally Off in DTMF mode. On during Pulse dialing. | | | | | | | | |
| 14 | 18 | DP | Dial Pulse (Output) This output will normally be OFF during Break and ON during make at Off-Hook (HK = V _{SS}). The output will be ON at On-Hook. (N-channel open drain). | | | | | | |

Tone/Pulse Dialer

Operation Procedures

Symbol definitions

- Dp: Pulse digit, 1,2,3,4,5,6,7,8,9,0.
- Dt: Tone digit, 1,2,3,4,5,6,7,8,9,0,*,#.
- ZiZiZi: Conversation.
- 0-01: Off-hook.
- 0-01: On-hook.
- ⎓ : Input level from low to high
- ⎒ : Input level from high to low.

used as a pause key in pulse mode. A pause can be cancelled with the [P], [T] or [R] keys during pause time when redialing.

4. Redialing
 - a. 0-01, Dp.....Dp, 0-01, 0-01, [R]
 - b. 0-01, Dt.....Dt, 0-01, 0-01, [R]

Note: The [R] key is disabled while Pulse or DTMF signals are being transmitted. When more than 32 digits have been dialed as a single number, redialing will be inhibited. The [#] key can be used as an [R] key in Pulse mode.

Recommended Dialing, Redialing, Mixed Dialing operations

1. Normal Dialing in Pulse Mode
0-01, Dp.....Dp, ZiZiZi, 0-01.
2. Normal Dialing in Tone Mode
 - a. 0-01, Dt.....Dt, ZiZiZi, 0-01.
 - b. 0-01, T, Dt.....Dt, ZiZiZi, 0-01. (UM91230C/D only)
3. Manual Dialing with Automatic Access Pause
 - a. 0-01, Dp, P, Dp.....Dp, ZiZiZi, 0-01 or
 - b. 0-01, Dt, P, Dt.....Dt, ZiZiZi, 0-01.

5. Inhibiting Redial
 - a. 0-01, Dp.....Dp, [R], [R]
 - b. 0-01, Dt.....Dt, [R], [R]

Note: Lift the receiver. Dial a number in Pulse mode. Press the [R] key twice.

Note: Each [P] key-in provides 3.6 seconds of pause time. [P] key entry is ignored if it is the first digit after going Off Hook. The [] key can also be

6. Pulse/Tone Switchable Operations
 - a. Mode switching by MODE SELECT input: (For UM91230C/D, OPERATION SELECT = V_{SS}.)
 0-01, Dp.....Dp, P, MODE SELECT, ⎓, Dt..... Dt
 |-----Pulse mode-----|Tone Model



UM91210/30

T-75-07-07

Note: If the **[P]** key is not pressed as one of the series of digits before or after the mode is switched, the following condition will result:

- (1) If a Tone digit is pressed after the Pulse digits have finished going out, the DTMF mode will be implemented after the last Pulse signal has been transmitted in this mode. Tone digits will be transmitted from the Tone Out pin as a DTMF signal when the corresponding keys are depressed.
- (2) If Tone digits are keyed in while the Pulse signal is still being sent out, the DTMF mode will take over but will be put on hold until the last Pulse signal has gone out. MODE OUT will flash to indicate that you are now in the hold state (for UM91230C/D only). Tone digits will be stored in Redial memory as DTMF data, but will not be transmitted from TONE OUT. When the data is ready for transmission from Redial Memory, the **[T]** (for UM91230C/D only), **[R]** or **[P]** keys can be pressed to reset the Hold state and the DTMF data will be serially transmitted.

b. Mode Switching by **[T]** key: (OPERATION SELECT = V_{DD} for UM91230C/D only)
 0-01, Dp,.....Dp, P, T, Dt.....Dt
 |—Pulse mode—|Tone mode|

Note: If the **[P]** key is not pressed serially before or after the **[T]** key, the following conditions will result:
 (1) If a Tone digit is pressed after the digits in

the Pulse mode have finished going out, the DTMF mode will become operational after transmission of the last Pulse signal. In this mode, the Tone digits are transmitted from TONE OUT as DTMF signals when the corresponding keys are depressed.

(2) If a Tone digit is pressed while the Pulse signals are still going out, the DTMF mode will become operational but will remain in the Pause state after the last Pulse signal has been transmitted. MODE OUT will flash to indicate that you are in the Pause state and the remaining Tone digits will be stored in redial memory as DTMF data but will not be transmitted from Tone Out. When the chip is ready to transmit the DTMF data in Redial Memory, the **[T]**, **[R]**, or **[P]** keys can be depressed to reset the Pause state and the DTMF data will be serially transmitted.

7. Redial with the Pause State Cancelled
 0-01, **[R]**, **[P]**, or **[T]**

Note: (1) Pause time can be cancelled by pressing the **[P]**, **[R]** or **[T]** keys during pause time when redialing. Any other pause in the series is also cancelled.

(2) If a pause was not stored before or after the mode was switched, the chip will go into the Pause state when the DTMF mode is activated. MODE OUT will flash to indicate that you are in the Pause state. DTMF data will be stored in the Redial Memory and not transmitted from Tone Out. After **[R]**, **[P]** or **[T]** are depressed to reset the Pause state, DTMF data will be serially transmitted.

Functional Description

- 1. N-Channel Open Drain Output:
 DP, MUTE, XMUTE, MODE OUT, KEY TONE

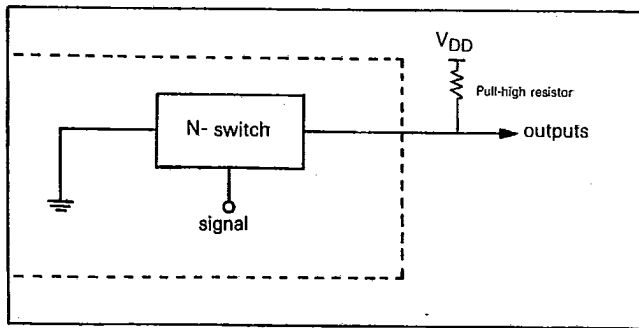



T-75-07-07

2. DTMF Generation

The DTMF signal is produced from the Tone Frequency Generator circuit with an NPN transistor-emitter-follower output buffer (Figure 1, below). The digitally synthesized sine wave is well designed, with an eight-level, 16-segment, fixed amplitude. It provides ($V_{DD}-1.8V$) a

reference voltage structure (Figure 2). The Total Harmonic Distortion (THD) of the DTMF output is 5% maximum. THD versus Operating Voltage and DTMF output amplitude versus Operating Voltage is shown in Figure 3 and Figure 4.

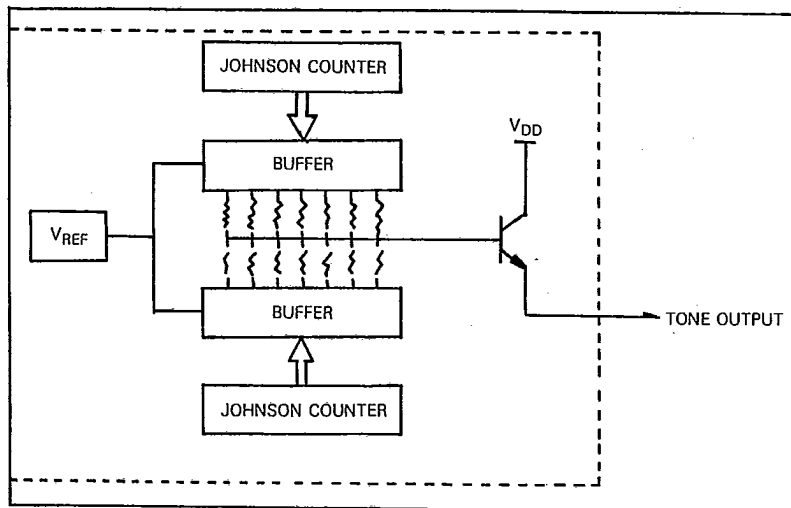

Figure 1.

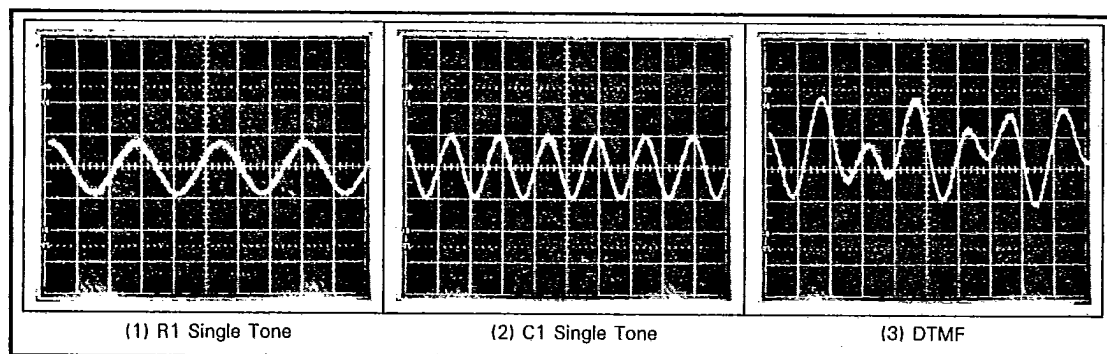

Figure 2: Waveforms

Tone/Pulse Dialer



UM91210/30

T-75-07-07

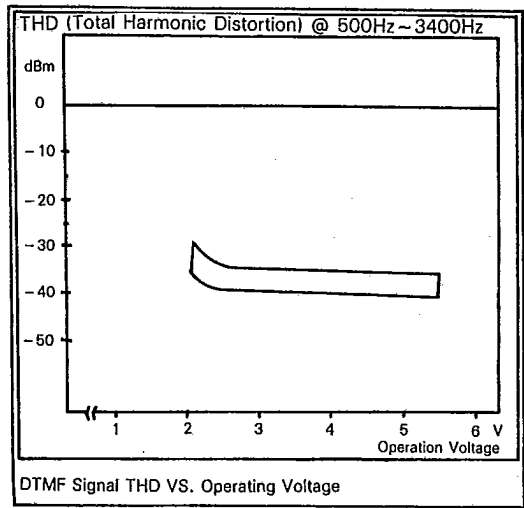

Figure 3

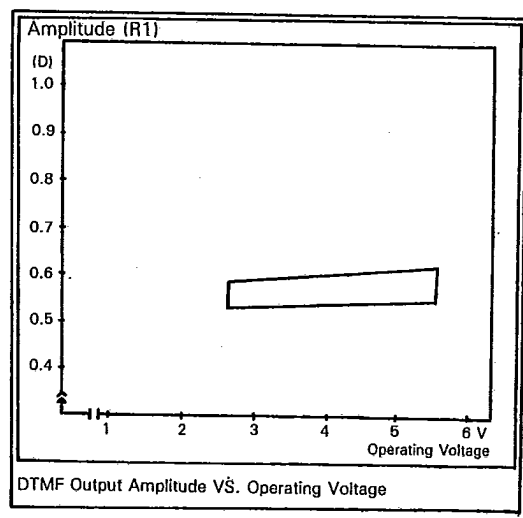

Figure 4

3. Single Tone Operation in DTMF Mode (Test Mode)

The * and # keys are used to trigger the chip into test mode by depressing them simultaneously during Off-Hook.

The single tone keyboard assignments are shown in the following table in contrast with normal mode.

Normal mode

| | | | |
|----------------|----------------|----------------|----------------|
| R ₁ | 1 | 2 | 3 |
| R ₂ | 4 | 5 | 6 |
| R ₃ | 7 | 8 | 9 |
| R ₄ | * | 0 | # |
| | C ₁ | C ₂ | C ₃ |

Single tone mode

| | | | |
|----------------|----------------|----------------|----------------|
| R ₁ | R ₁ | C ₂ | C ₃ |
| R ₂ | C ₁ | C ₂ | R ₂ |
| R ₃ | R ₃ | C ₂ | C ₃ |
| R ₄ | C ₁ | R ₄ | C ₃ |
| | C ₁ | C ₂ | C ₃ |



UM91210/30

T-75-07-07

Timing Diagrams

1. PULSE MODE TIMING DIAGRAM

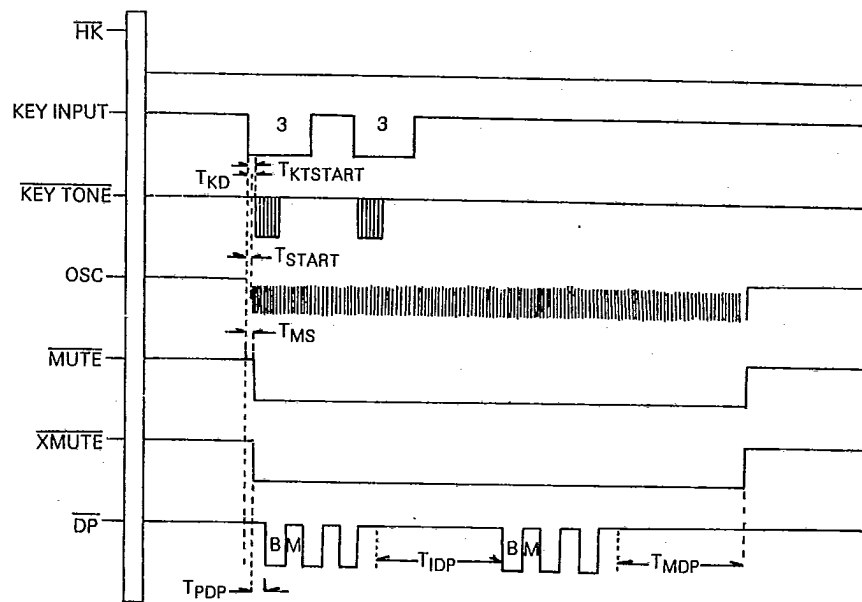

2. TONE MODE TIMING DIAGRAM

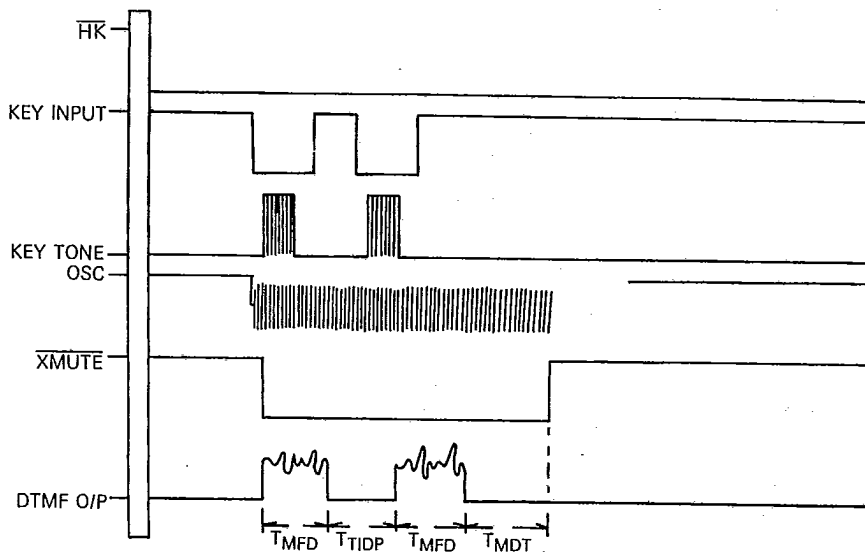



UM91210/30

3. NORMAL PULSE to TONE MIXED DIALING VIA MODE SELECT SLIDE SWITCH (OPERATION SELECT = V_{SS} for UM91230C/D)

T-75-07-07

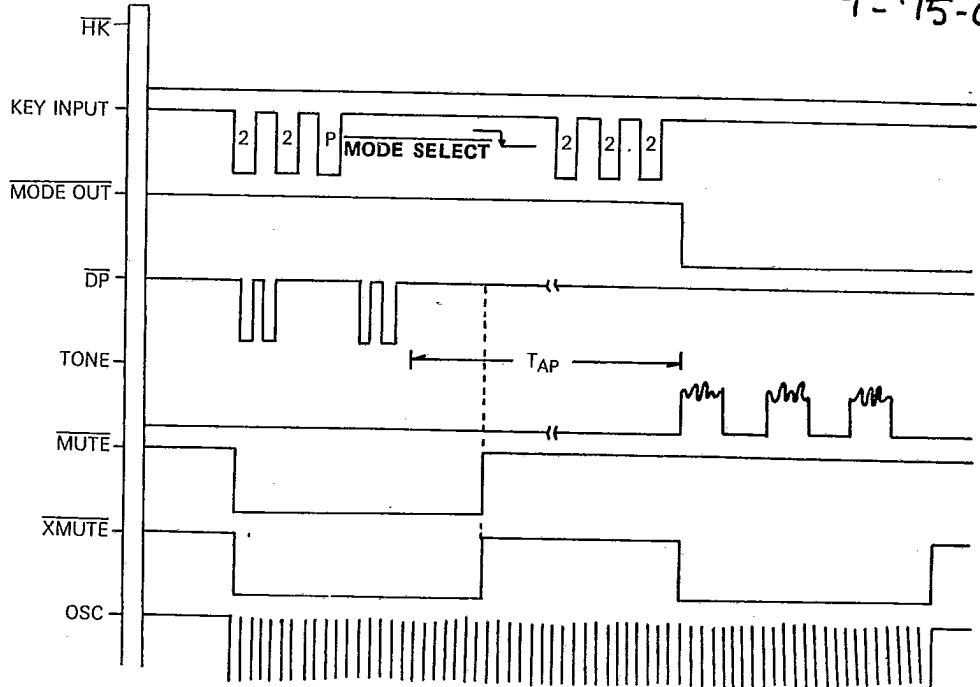

4. NORMAL PULSE to TONE MIXED DIALING VIA [T] KEY (OPERATION SELECT = V_{DD} THIS OPERATION for UM91230C/D ONLY.)

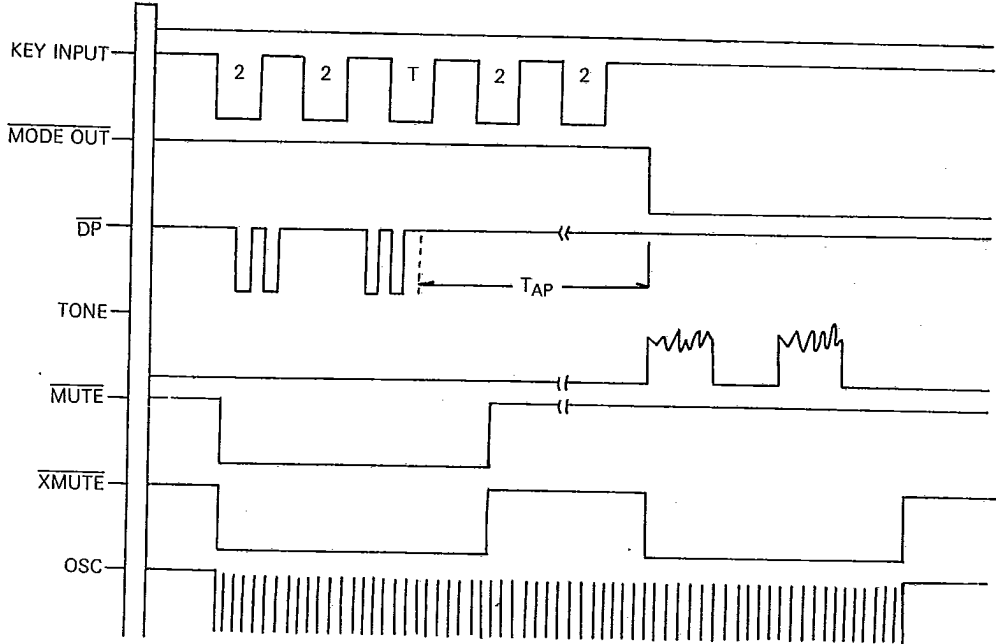



UM91210/30

Application Circuits
1. UM91230C/D

T-75-07-07

1) Switching mode by **T** key (MODE SELECT, OPERATION SELECT = V_{DD})

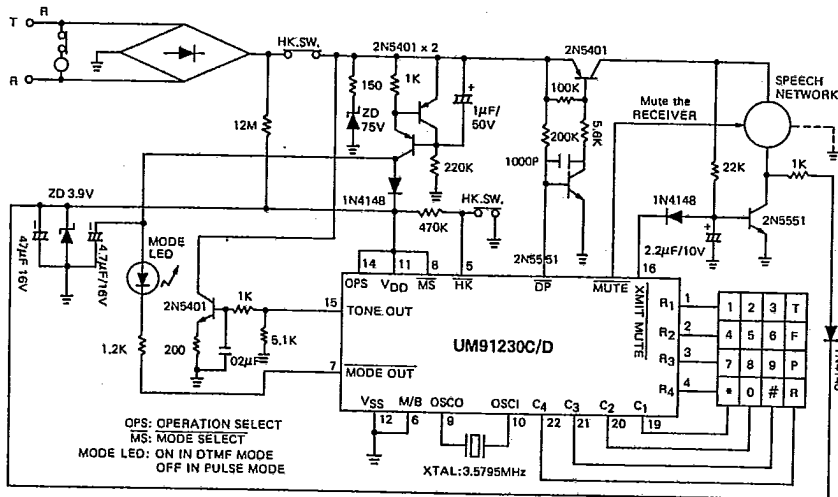

2) Switching mode by MODE SELECT (OPERATION SELECT = V_{SS})

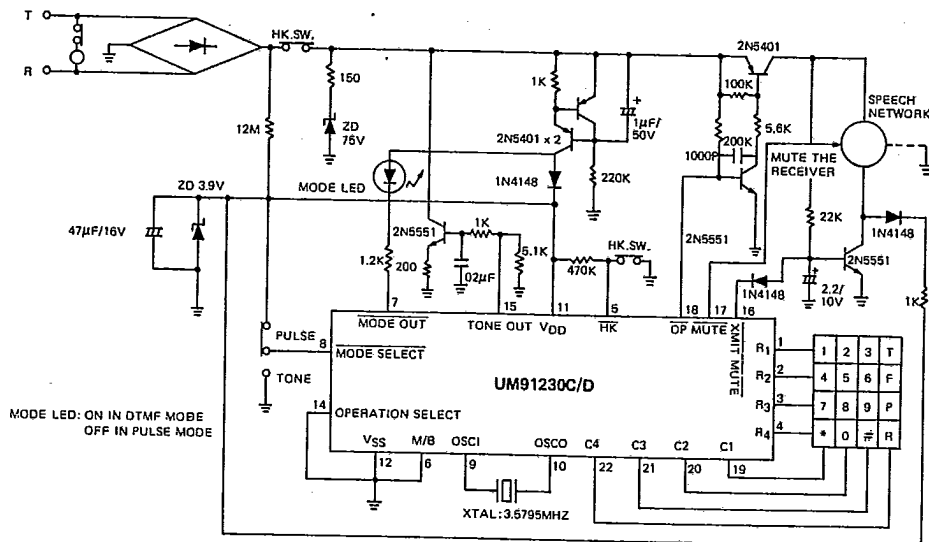



UM91210/30

T-75-07-07

2. UM91210C/D

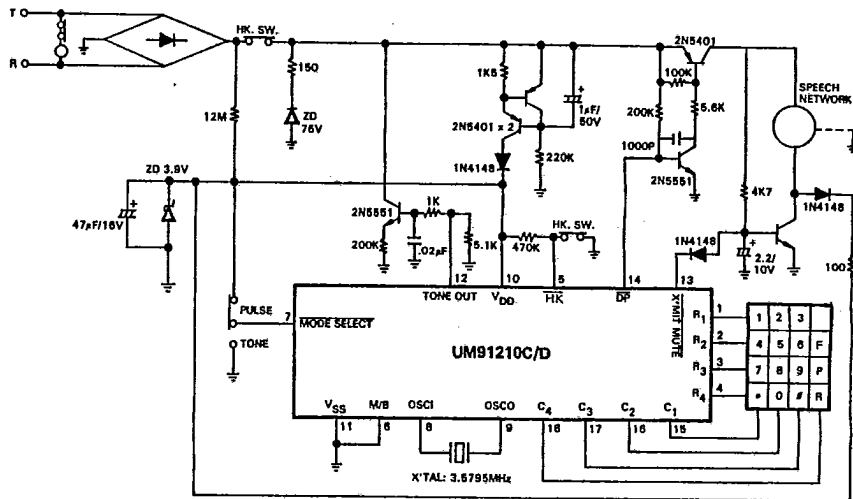

Test Circuits

(A)

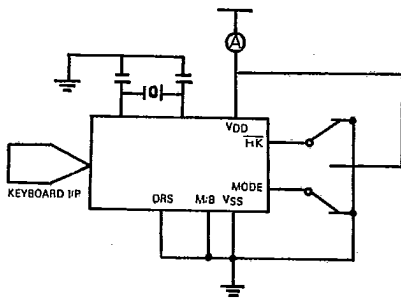

(B)

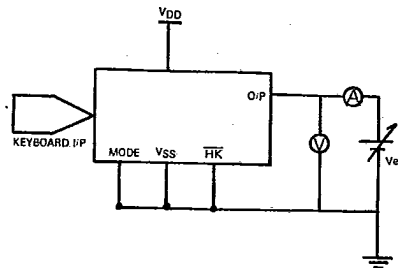

(C)

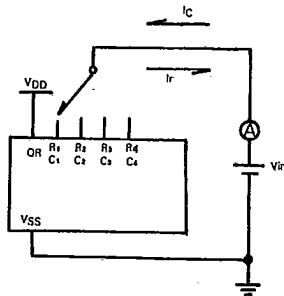

(D)

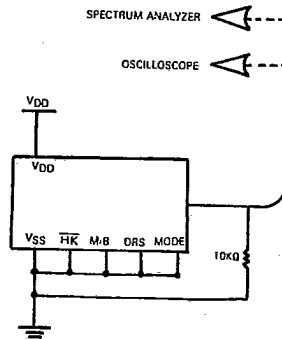

- OSCILLOSCOPE: TEKTRONIX 468
- SPECTRUM ANALYZER: HP 3585A