

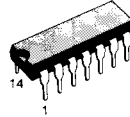

## QUAD 2-INPUT AND GATE

### DESCRIPTION

The T54LS08/T74LS08 is a high speed QUAD 2-INPUT AND GATE fabricated in LOW POWER SCHOTTKY technology.



**B1**  
Plastic Package

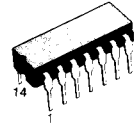

**D1/D2**  
Ceramic Package



**M1**  
Micro Package



**C1**  
Plastic Chip Carrier

### ORDERING NUMBERS:

T54LS08 D2

T74LS08 C1

T74LS08 D1

T74LS08 M1

### PIN CONNECTION (top view)

#### DUAL IN LINE

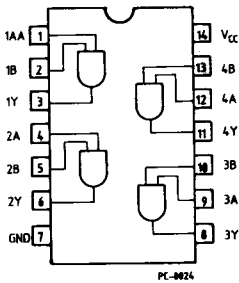

#### CHIP CARRIER

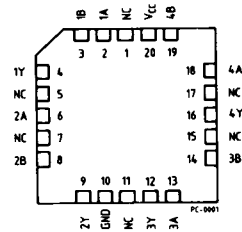

NC = No Internal Connection

### SCHEMATIC

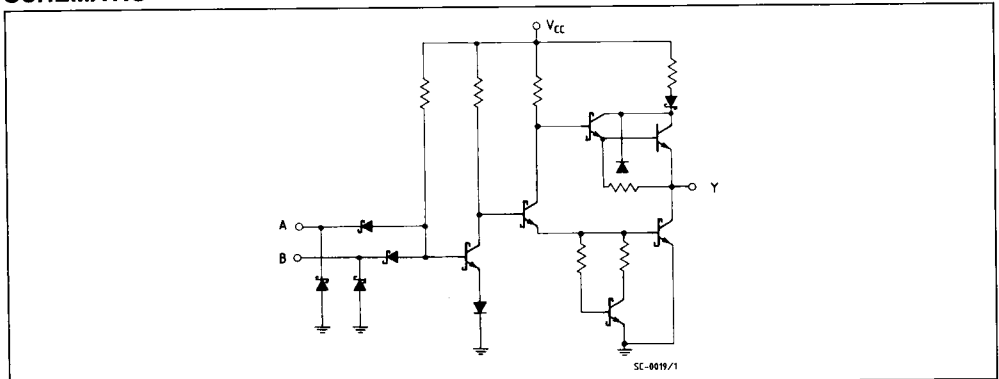



## LOGIC DIAGRAM AND TRUTH TABLE



A	B	Y
L	X	L
X	L	L
H	H	H

L = LOW Voltage Level  
H = HIGH Voltage Level  
X = Don't Care

## ABSOLUTE MAXIMUM RATINGS

Symbol	Parameter	Value	Unit
$V_{CC}$	Supply Voltage	-0.5 to 7	V
$V_I$	Input Voltage, Applied to Input	-0.5 to 15	V
$V_O$	Output Voltage, Applied to Output	-0.5 to 10	V
$I_I$	Input Current, Into Inputs	-30 to 5	mA
$I_O$	Output Current, Into Outputs	50	mA

Stresses in excess of those listed under "Absolute Maximum Ratings" may cause permanent damage to the device. This is a stress rating only and functional operation of the device at these or any other conditions in excess of those indicated in the operational sections of this specification is not implied. Exposure to absolute maximum rating conditions for extended periods may affect device reliability.

## GUARANTEED OPERATING RANGES

Part Numbers	Supply Voltage			Temperature
	Min	Typ	Max	
T54LS08D2	4.5 V	5.0 V	5.5 V	-55°C to +125°C
T74LS08XX	4.75 V	5.0 V	5.25 V	0°C to +70°C

XX = package type.

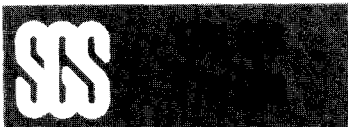

## DC CHARACTERISTICS OVER OPERATING TEMPERATURE RANGE

Symbol	Parameter		Limits			Test Conditions (Note 1)	Units
			Min.	Typ.	Max.		
V <sub>IH</sub>	Input HIGH Voltage		2.0			Guaranteed input HIGH Voltage	V
V <sub>IL</sub>	Input LOW Voltage	54			0.7	Guaranteed input LOW Voltage	V
		74			0.8		
V <sub>CD</sub>	Input Clamp Diode Voltage			-0.65	-1.5	V <sub>CC</sub> = MIN, I <sub>IN</sub> = -18mA	V
V <sub>OH</sub>	Output HIGH Voltage	54	2.5	3.4		V <sub>CC</sub> = MIN, I <sub>OH</sub> = -400μA, V <sub>IN</sub> = V <sub>IH</sub>	V
		74	2.7	3.4			
V <sub>OL</sub>	Output LOW Voltage	54,74		0.25	0.4	I <sub>OL</sub> = 4.0mA	V
		74		0.35	0.5	I <sub>OL</sub> = 8.0mA	
I <sub>IH</sub>	Input HIGH Current			1.0	20 0.1	V <sub>CC</sub> = MAX, V <sub>IN</sub> = 2.7V V <sub>CC</sub> = MAX, V <sub>IN</sub> = 7.0V	μA mA
I <sub>IL</sub>	Input LOW Current				-0.36	V <sub>CC</sub> = MAX, V <sub>IN</sub> = 0.4V	mA
I <sub>OS</sub>	Output Short Circuit Current (Note 2)		-20		-100	V <sub>CC</sub> = MAX, V <sub>OUT</sub> = 0V	mA
I <sub>CCH</sub>	Supply Current HIGH			2.4	4.8	V <sub>CC</sub> = MAX, Inputs Open	mA
I <sub>CCL</sub>	Supply Current LOW			4.4	8.8	V <sub>CC</sub> = MAX, V <sub>IN</sub> = 0V	mA

## AC CHARACTERISTICS: T<sub>A</sub> = 25°C (See page 576 for AC test circuit and waveforms)

Symbol	Parameter		Limits			Test Conditions	Units
			Min.	Typ.	Max.		
t <sub>PLH</sub>	Turn Off Delay, Input to Output			8.0	15	V <sub>CC</sub> = 5.0V C <sub>L</sub> = 15pF	ns
t <sub>PHL</sub>	Turn On Delay, Input to Output			10	20		ns

### Notes:

- 1) For conditions shown as MIN or MAX, use the appropriate value specified under guaranteed operating ranges.
- 2) Not more than one output should be shorted at a time.
- 3) Typical values are at V<sub>CC</sub> = 5.0V, T<sub>A</sub> = 25°C.