

HIGH VOLTAGE DRIVER FOR CFL

- n BCD-OFF LINE TECHNOLOGY
- n FLOATING SUPPLY VOLTAGE UP TO 570V
- n GND REFERRED SUPPLY VOLTAGE UP TO 18V
- n UNDER VOLTAGE LOCK OUT
- n CLAMPING ON V_s
- n DRIVER CURRENT CAPABILITY:
30mA SOURCE
70mA SINK
- n PREHEAT AND FREQUENCY SHIFT TIMING

MULTIPOWER BCD TECHNOLOGY

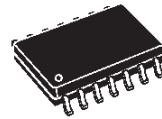

SO14

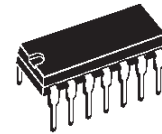

DIP14

ORDERING NUMBERS:
L6567D L6567

DESCRIPTION

The device is a monolithic high voltage integrated circuit designed to drive CFL and small TL lamps with a minimum part count.

It provides all the necessary functions for proper preheat, ignition and steady state operation of the lamp:

- ◆ variable frequency oscillator;

- ◆ settable preheating and ignition time;
- ◆ capacitive mode protection;
- ◆ lamp power independent from mains voltage variation.

Besides the control functions, the IC provides the level shift and drive function for two external power MOS FETs in a half-bridge topology.

BLOCK DIAGRAM

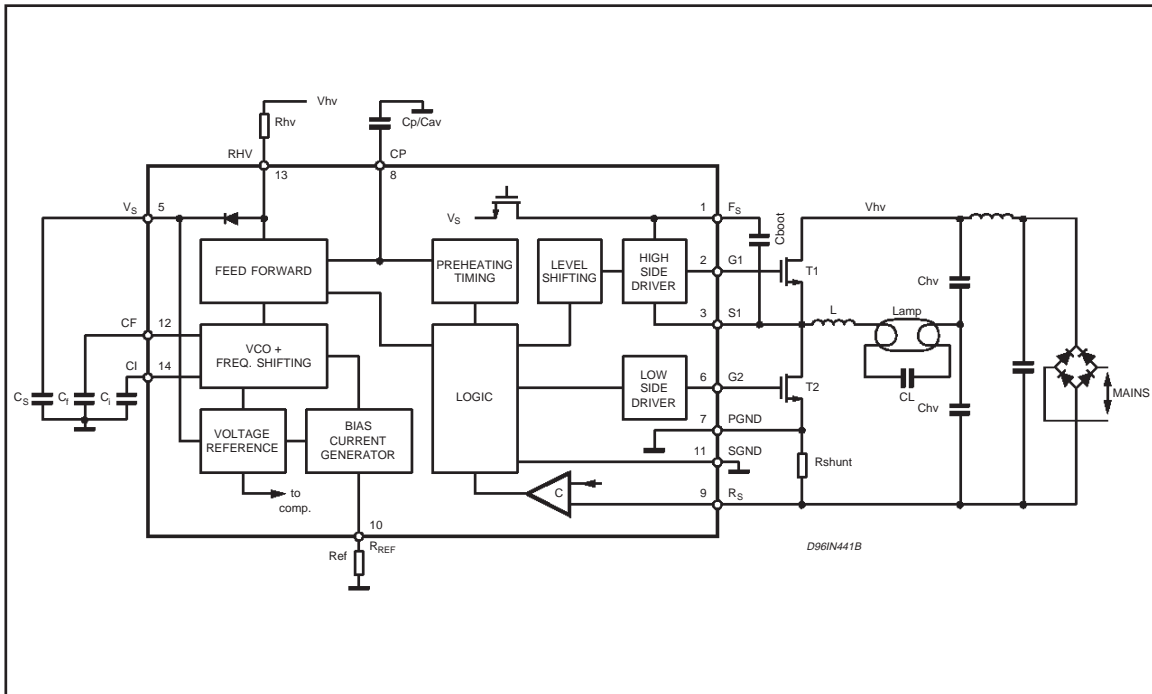

PIN FUNCTION

N°	Pin	Description
1	F _S	Floating Supply of high side driver
2	G1	Gate of high side switch
3	S1	Source of high side switch
4	NC	High Voltage Spacer. (Should be not connected)
5	V _S	Supply Voltage for GND level control and drive
6	G2	Gate of low side switch
7	PGND	Power Ground
8	CP	First timing (TPRE TIGN), then averaging the ripple in the representation of the HVB (derived through RHV).
9	R _S	R _{SHUNT} : current monitoring input
10	RREF	Reference resistor for current setting
11	SGND	Signal Ground. Internally Connected to PGND
12	CF	Frequency setting capacitor
13	RHV	Start-up supply resistor, then supply voltage sensing.
14	CI	Timing capacitor for frequency shift

PIN CONNECTION (Top view)

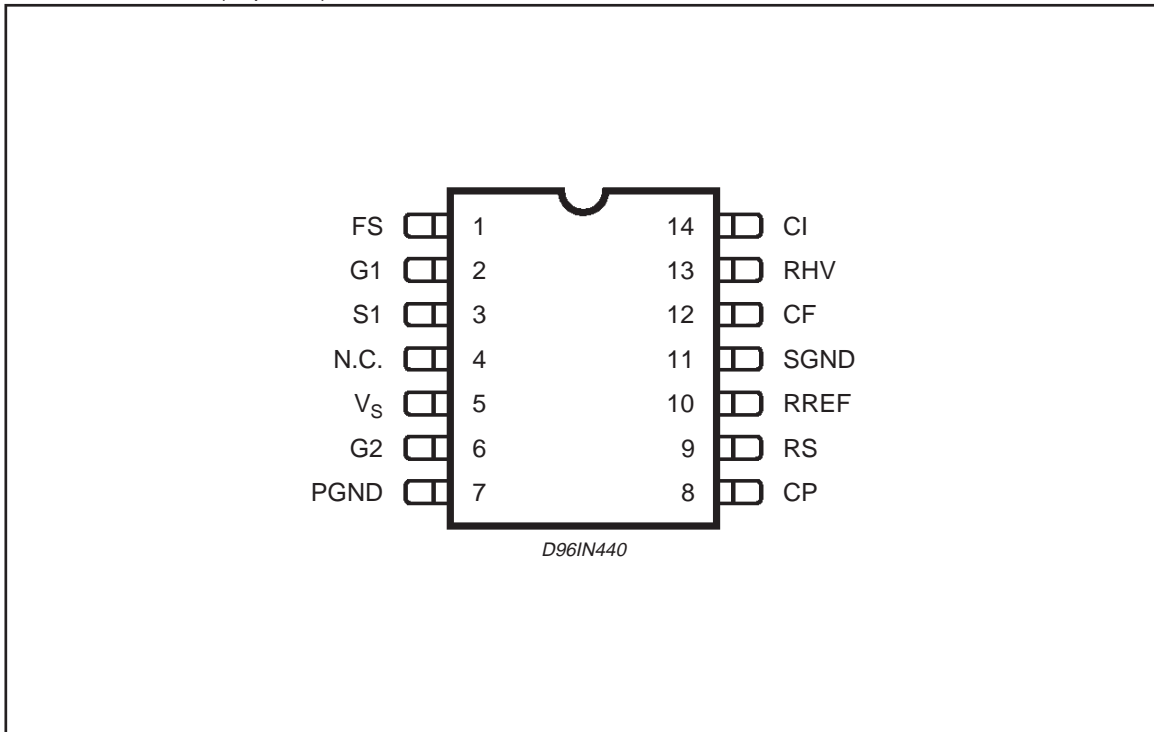

ABSOLUTE MAXIMUM RATINGS

Symbol	Parameter	Value	Unit
V _S	Low Voltage Supply	18 (1)	V
V _{RHV}	Mains Voltage Sensing	V _S + 2V _{BE} (2)	
V _{CP}	Preheat/Averaging	5	V
V _{CF}	Oscillator Capacitor Voltage	5	V
V _{CI}	Frequency Shift Capacitor Voltage	5	V
V _{RREF}	Reference Resistor Voltage	5	V
V _{RS}	Current Sense Input Voltage	-5 to 5	V
	transient 50ns	-15	V
V _{G2}	Low Side Switch Gate Output	18	V
V _{S1}	High Side Switch Source Output: normal operation	-1 to 373	V
	0.5sec mains transient	-1 to 550	V
V _{G1}	High Side Switch Gate Output: normal operation	-1 to 391	V
	0.5sec mains transient	-1 to 568	V
	with respect to pin S1	V _{be} to V _S	V
V _{FS}	Floating Supply Voltage: normal operation	391	V
	0.5sec mains transient	568	V
V _{FS/S1}	Floating Supply vs S1 Voltage	18	V
ΔV _{FS} /ΔT	VFS Slew Rate (Repetitive)	-4 to 4	V/ns
ΔV _{S1} /ΔT	VS1 Slew Rate (Repetitive)	-4 to 4	V/ns
I _{RHV}	Current Into R _{HV}	3 (3)	mA
I _{Vs}	Clamped Current into V _S	200 (4)	mA
T _{stg}	Storage Temperature	-40 to 150	°C
T _j	Junction Temperature	-40 to 150	°C

NOTES: (1) Do not exceed package thermal dissipation limits

(2) For V_S ≤ V_S high 1

(3) For V_S > V_S high 1

(4) Internally Limited

Note: ESD immunity for pins 1, 2 and 3 is guaranteed up to 900 V (Human Body Model)

ELECTRICAL CHARACTERISTICS

($V_S = 12V$; $R_{REF} = 30K\Omega$; $C_F = 100pF$; $T_j = 25^\circ C$; unless otherwise specified.)

Symbol	Parameter	Test Condition	Min.	Typ.	Max.	Unit
--------	-----------	----------------	------	------	------	------

V_S - SUPPLY VOLTAGE SECTION

$V_{S\ high\ 1}$	V_S Turn On Threshold		10.7	11.7	12.7	V
$V_{S\ high2}$	V_S Clamping Voltage	$V_S = 20mA$	12	13	14	V
$V_{S\ low\ 2}$	V_S Turn Off Threshold		9	10	11	V
$V_{S\ HYST}$	Supply Voltage Hysteresis		1.5	1.65	1.8	V
$V_{S\ low\ 1}$	V_S Voltage to Guarantee $V_{G1} = "0"$ and $V_{G2} = "1"$		1		6	V
I_{SSP}	V_S Supply Current at Start Up	$V_S = 10.6V$ Before turn on	50		250	mA
I_{SOP}	V_S Supply Operative Current	$V_S = V_{S\ high\ 1}$			1.2	mA

OSCILLATOR SECTION

$f_{osc\ min}$	Minimum Oscillator frequency	$I_{RHV} = 0mA$; $CI = 5V$	41.7	43	44.29	KHz
$f_{osc\ 600m}$	Feed Forward Frequency	$I_{RHV} = 600mA$	47.88	50.4	52.92	KHz
$f_{osc\ 1mA}$	Feed Forward Frequency	$I_{RHV} = 1mA$	79.8	84	88.2	KHz
$f_{osc\ max}$	Maximum Oscillator Frequency	$CI = 0V$	96.75	107.5	118.25	KHz
$\Delta I_{CF}/\Delta V_{CI}$	Oscillator Transconductance		9		17.5	$\mu A/V$

PREHEAT/IGNITION SECTION

P.H.T.	Preheat Time	$C_p = 150nF$	0.88	1	1.12	sec
P.H.clocks	Number of Preheat Clocks			16		
IGN.clocks	Number of Ignition Clocks			15		

RATE OF FREQUENCY CHANGE SECTION

ICIP charge	CI Charging Current During Preheat		106	118	130	mA
ICII charge	CI Charging Current During Ignition		1	1.2	1.4	mA
ICI disch	CI Discharge Current		-52	-47	-42	mA
$V_{TH\ CI}$	CI Low Voltage Threshold		10		100	mV

RS - THRESHOLD SECTION

V_{CMTH}	Capacitive Mode Voltage Threshold		0	20	40	mV
V_{PH}	Preheat Voltage Threshold		-0.64	-0.6	-0.56	V

G1 - G2 DELAY TIMES SECTION

$G1_{DON}$	On Delay of G1 Output		1.05	1.4	1.75	μs
------------	-----------------------	--	------	-----	------	---------

ELECTRICAL CHARACTERISTICS (Continued)

Symbol	Parameter	Test Condition	Min.	Typ.	Max.	Unit
$G2_{DON}$	On Delay of G2 Output		1.05	1.4	1.75	μs
$\frac{G1_{DON} + G1_{ON}}{G2_{DON} + G2_{ON}}$	Ratio between Delay Time + Conduction Time of G1 and G2	$I_{RHV} = 1mA; CI = 5V$ $CI = 0V$	0.87 0.77		1.15 1.30	

LOW SIDE DRIVER SECTION

Ron G2 so	G2 Source Output Resistance	$V_S = 12V, V = 3V$	80		190	Ω
Ron G2 si	G2 Sink Output Resistance	$V_S = 12V, V = 3V$	65		125	Ω
Ron G1 so	G1 Source Output Resistance	$V_S = 10V, V = 3V$	80		190	Ω
Ron G1 si	G1 Sink Output Resistance	$V_S = 10V, V = 3V$	65		125	Ω

HIGH SIDE DRIVER SECTION

I_{FSLK}	Leakage Current of FS PIN to GND	$V_{FS} = 568V; G1 = L$ $V_{FS} = 568V; G1 = H$			5 5	μA μA
I_{S1LK}	Leakage Current of S1 PIN to GND	$V_{S1} = 568V; G1 = L$ $V_{S1} = 568V; G1 = H$			5 5	μA μA

BOOTSTRAP SECTION

Boot Th	BOOTSTRAP Threshold	$V_S = 10.6V$ before turn on	5 (*)			V
---------	---------------------	------------------------------	-------	--	--	---

AVERAGE RESISTOR

$R_{AVERAGE}$	Average Resistor		27	38.5	50	$k\Omega$
---------------	------------------	--	----	------	----	-----------

(*) Before starting the first commutation; when switching 6V is guaranteed.

General operation

The L6567 uses a small amount of current from a supply resistor(s) to start the operation of the IC. Once start up condition is achieved, the IC turns on the lower MOS transistor of the half bridge which allows the bootstrap capacitor to charge. Once this is achieved, the oscillator begins to turn on the upper and lower MOS transistors at high frequency, and immediately ramps down to a preheat frequency. During this stage, the IC preheats the lamp and after a predetermined time ramps down again until it reaches the final operating frequency. The IC monitors the current to determine if the circuit is operating in capacitive mode. If capacitive switching is detected, the IC increases the output frequency until zero-voltage switching is resumed.

Startup and supply in normal operation

At start up the L6567 is powered via a resistor connected to the R_{HV} pin (pin 13) from the rectified mains. The current charges the C_S capacitor connected to the V_S pin (pin 5). When the V_S voltage reaches the threshold V_{S_LOW1} (max 6V), the low side MOS transistor is turned on while the high side one is kept off. This condition assures that the bootstrap capacitor is charged. When V_{S_HIGH1} threshold is reached the oscillator starts, and the R_{HV} pin does not provide anymore the supply current for the IC (see fig.1).

Figure 1. Start up

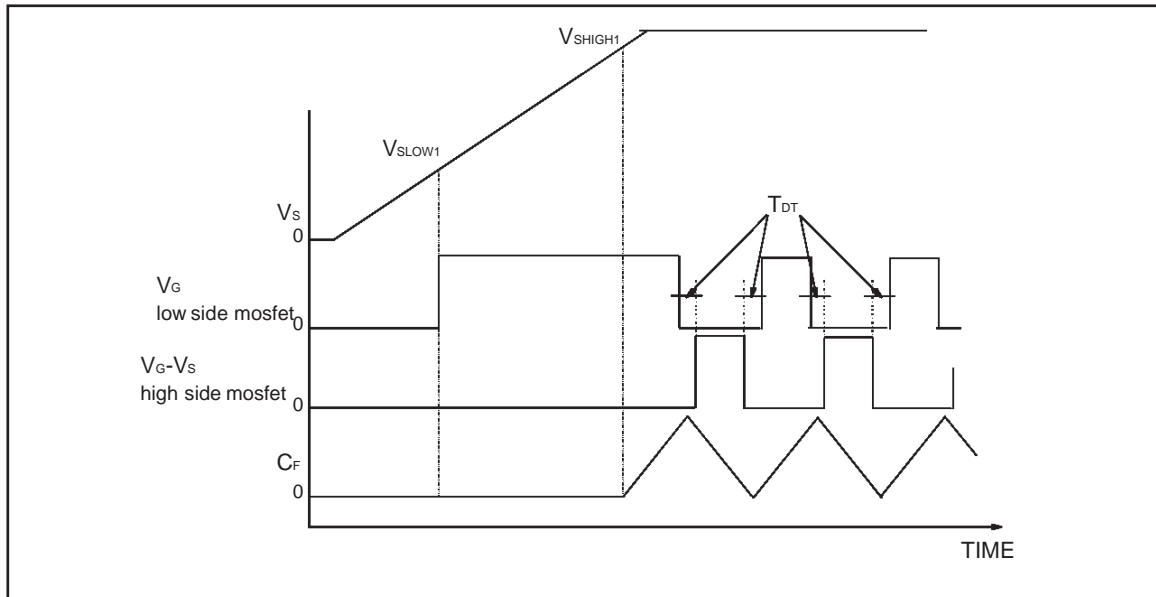

Oscillator

The circuit starts oscillating when the voltage supply V_S has reached the $V_{S\ HIGH1}$ threshold. In steady state condition the oscillator capacitor C_F (at pin 12) is charged and discharged symmetrically with a current set mainly by the external resistor R_{REF} connected to pin 10. The value of the frequency is determined by capacitor C_F and resistor R_{REF} . This fixed value is called F_{MIN} . A dead time T_{DT} between the ON phases of the transistors is provided for avoiding cross conduction, so the duty cycle for each is less than 50%. The dead time depends on R_{REF} value (fig. 7).

The IC oscillating frequency is between F_{MIN} and $F_{MAX} = 2.5 \cdot F_{MIN}$ in all conditions.

Preheating mode

The oscillator starts switching at the maximum frequency F_{MAX} . Then the frequency decreases at once to reach the programmed preheating frequency (fig.2). The rate of decreasing (df/dt) is determined by the external capacitor C_1 (pin 14). The preheat time T_{PRE} is adjustable with external components (R_{REF} and C_P). The preheat current is adjusted by sense resistance R_{SHUNT} . During the preheating time the load current is sensed with the sense resistor R_{SHUNT} (connected between pin 9-RS- and pin 7-PGND-). At pin 9 the voltage drop on R_{SHUNT} is sensed at the moment the low side MOS FET is turned off. There is an internal comparator with a fixed threshold V_{PH} : if $V_{RS} > V_{PH}$ the frequency is decreased and if $V_{RS} < V_{PH}$ the frequency is increased. If the V_{PH} threshold is reached, the frequency is held constant for the programmed preheating time T_{PRE} .

T_{PRE} is determined by the external capacitor C_P (pin8) and by the resistor R_{REF} . C_P is charged 16 times with a current that depends on R_{REF} , and these 16 cycles determine the T_{PRE} .

So the preheat mode is programmable with external components as far as T_{PRE} is concerned (R_{REF} & C_P) and as far as the preheating current is concerned (choosing properly R_{SHUNT} and the resonant load components: L and C_L).

The circuit is held in the preheating mode when pin 8 (C_P) is grounded.

In case F_{MIN} is reached during preheat, the IC assumes an open load. Consequently the oscillation stops with the low side MOS transistor gate on and the high side gate off. This condition is kept until V_S undershoots $V_{S\ LOW1}$.

Figure 2. Preheating and ignition state.

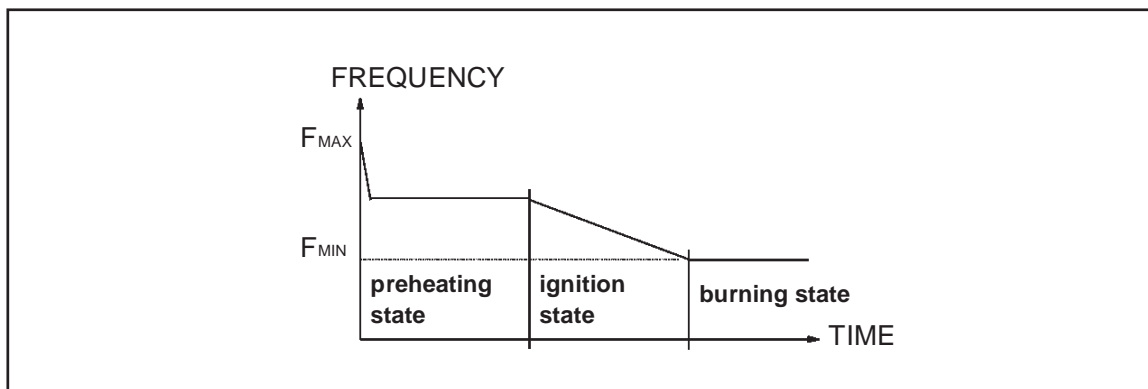

Ignition mode

At the end of the preheat phase the frequency decreases to the minimum frequency (F_{MIN}), causing an increased coil current and a high voltage appearing across the lamp. That is because the circuit works near resonance. This high voltage normally ignites the lamp. There is no protection to avoid high ignition currents through the MOS transistors when the lamp doesn't ignite. This only occurs in an end of lamp life situation in which the circuit may break. Now the lowest frequency is the resonance frequency of L and C_L (the capacitor across the lamp).

The ignition phase finishes when the frequency reaches F_{MIN} or (at maximum) when the ignition time has elapsed. The ignition time is related to T_{PRE} : $T_{IGN} = (15/16) \cdot T_{PRE}$. The C_P capacitor is charged 15 times with the same current used to charge it during T_{PRE} .

The frequency shifting slope is determined by C_I .

During the ignition time the V_{RS} monitoring function changes in the capacitive mode protection.

Steady state operation: feed forward frequency

The lamp starts operating at F_{MIN} , determined by R_{REF} and C_F directly after the ignition phase. To prevent too high lamp power at high mains voltages, a feed forward correction is implemented. At the end of the preheat phase the R_{HV} pin is connected to an internal resistor to sense the High Voltage Bus. If the current in this resistor increases and overcomes a value set by R_{REF} , the current that charges the oscillator capacitor C_F increases too. The effect is an increase in frequency limiting the power in the lamp. In order to prevent feed forward of the ripple of the V_{HV} voltage, the ripple is filtered with capacitor C_P on pin 8 and an integrated resistor $R_{AVERAGE}$.

Figure 3. Burn state

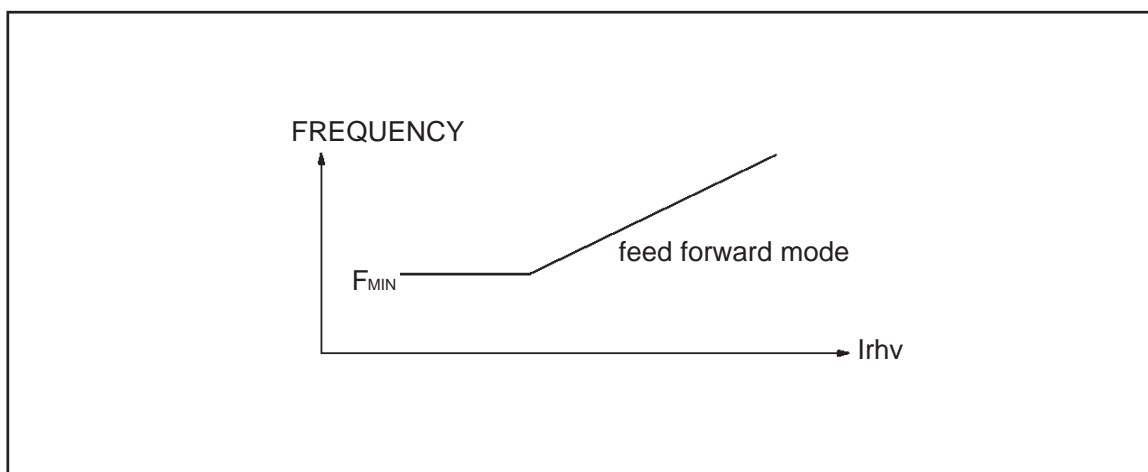

Capacitive mode protection

During ignition and steady state the operating frequency is higher than the resonance frequency of the load (L_{CL} , R_{LAMP} and $R_{FILAMENT}$), so the transistors are turned on during the conduction time of the body diode in order to maintain Zero Voltage Switching.

If the operating frequency undershoots the resonance frequency ZVS doesn't occur and causes hard switching of the MOS transistors. The L6567 detects this situation by measuring V_{RS} when the low side MOS FET is turned on. At pin 9 there is an internal comparator with threshold V_{CMTH} (typ~20mV): if $V_{RS} < V_{CMTH}$ capacitive mode is assumed and the frequency is increased as long as this situation is present. The shift is determined by C_I .

Steady state frequency

At any time during steady state the frequency is determined by the maximum on the following three frequencies:

$$f_{STEADY STATE} = \text{MAX} \{ F_{MIN}, f_{FEED FORWARD}, f_{CAPACITIVE MODE PROTECTION} \}$$

IC supply

At start up the IC is supplied with a current that flows through R_{HV} and an internal diode to the V_S pin which charges the external capacitor C_S . In steady state condition R_{HV} is used as a mains voltage sensor, so it doesn't provide anymore the supply current. The easiest way to charge the C_S capacitor (and to supply the IC) is to use a charge pump from the middle point of the half bridge.

To guarantee a minimum gate power MOS drive, the IC stops oscillating when V_S is lower than V_{SHIGH2} . It will restart once the V_S will become higher than V_{SHIGH1} . A minimum voltage hysteresis is guaranteed. The IC restarts operating at $f = F_{MAX}$, then the frequency shifts towards F_{MIN} . The timing of this frequency shifting is T_{IGN} (that is: C_P capacitor is charged and discharged 15 times). Now the oscillator frequency is controlled as in standard burning condition (feed forward and capacitive mode control). Excess charge on C_S is drained by an internal clamp that turns on at voltage V_{SCL} .

Ground pins

Pin 7(PGND) is the ground reference of the IC with respect to the application. Pin 11(SGND) provides a local signal ground reference for the components connected to the pins C_P , C_I , R_{REF} and C_F .

Relationship between external components and sistem working condition

L6567 is designed to drive CFL and TL lamps with a minimum part count topology. This feature implies that each external component is related to one or more circuit operating state.

This table is a short summary of these relationships:

$F_{MIN} \rightarrow R_{REF} \ \& \ C_F$

$F_{FEED FORWARD} \rightarrow C_F \ \& \ I_{RHV}$

$T_{PRE} \ \& \ T_{IGN} \rightarrow C_P \ \& \ R_{REF}$

$F_{PRE} \rightarrow R_{SHUNT}, L, C_L, LAMP$

$T_{DT} \rightarrow R_{REF}$

$df/dt \rightarrow C_I$

Some useful formulas can well approximate the values:

$$F_{MIN} \cong \frac{1}{8 \cdot R_{REF} \cdot C_F}$$

If I_{RHV} is greater than: $I_{RHV} \geq \frac{15}{R_{REF}}$, the feed forward frequency is settled and the frequency value is fitted by the following expression:

$$F_{FEED FORWARD} \cong \frac{I_{RHV}}{121 \cdot C_F}$$

Other easy formulas fit rather well:

$$T_{DT} \cong 46.75 \cdot 10^{-12} \cdot R_{REF}$$

$$T_{PRE} \cong 224 \cdot C_P \cdot R_{REF}$$

As far as df/dt is concerned, there are no easy formulas that fit the relation between C_F , R_F , and C_I . C_I is charged and discharged by three different currents that are derived from different mirroring ratios by the current flowing on R_{REF} . The voltage variations on C_I are proportional to the current that charges C_F , that is to say they are proportional to df/dt .

The values obtained in the testing conditions ($C_I = 100\text{nF}$) are:

during preheating and working conditions the typical frequency increase is $\sim 20\text{KHz/ms}$, the typical decrease is $\sim -10\text{KHz/ms}$;

During ignition the frequency variation is $\sim -200\text{Hz/ms}$.

If slower variations are needed, C_I has to be increased.

Due to these tight relationships, it is recommended to follow a precise procedure: first R_{HV} has to be chosen looking at startup current needs and dissipation problems. Then the feed forward frequency range has to be determined, and so C_F is set.

Given a certain C_F , R_{REF} is set in order to fix F_{MIN} . Now C_P can be chosen to set the desired T_{PRE} and T_{IGN} .

The other external parameters (R_{SHUNT} and C_I) can be chosen at the end because they are just related to a single circuit parameters.

Figure 4. IC Operation

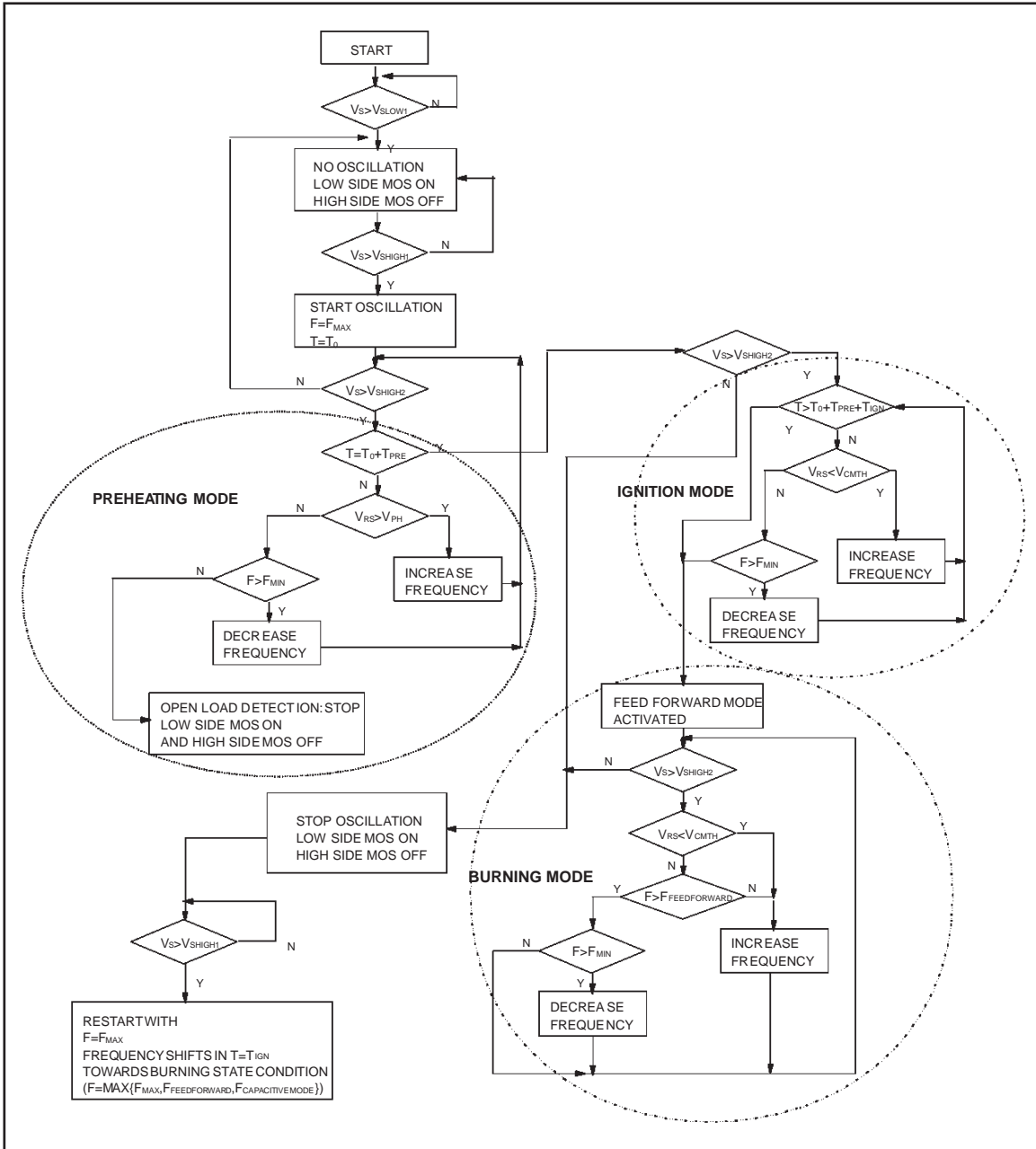

Figure 5. Working frequency vs I_{RHV} @ $R_{REF} = 30Kohm$

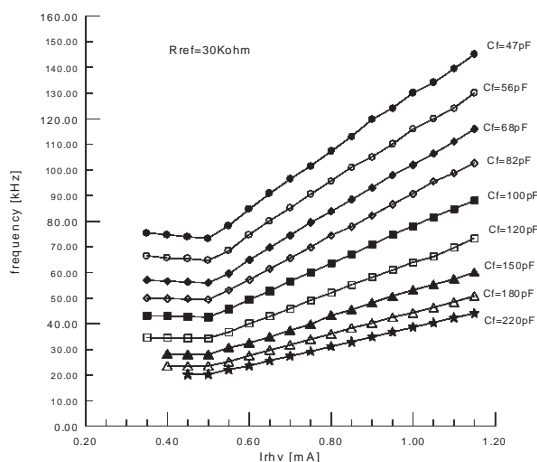

Figure 8. Frequency vs I_{RHV} @ $C_f = 82pF$

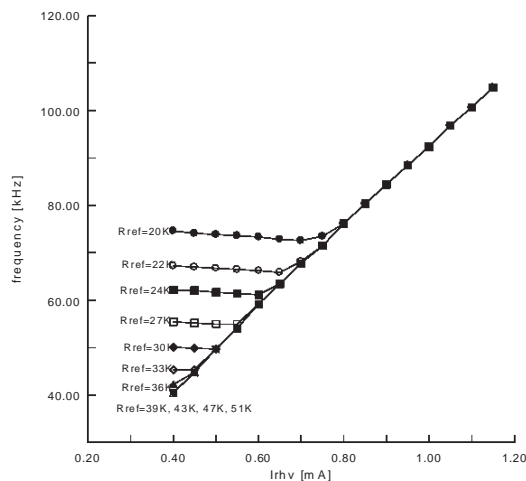

Figure 6. Frequency vs C_f @ $R_{REF}=30Kohm$

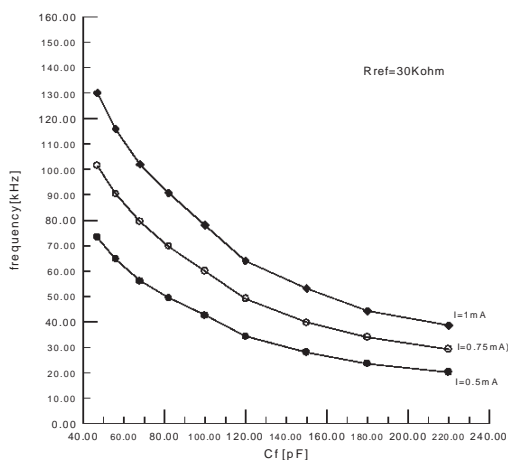

Figure 9. Frequency vs I_{RHV} @ $C_f=100pF$

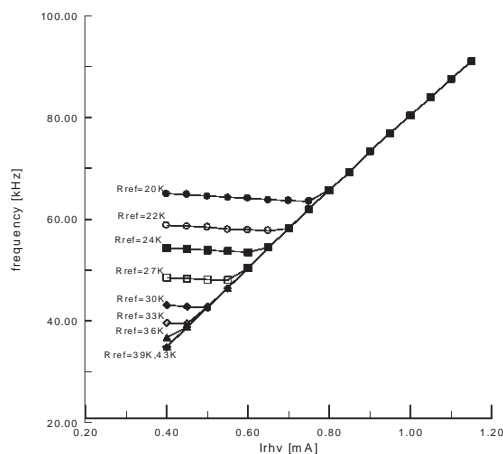

Figure 7. T_{dt} vs R_{REF} @ $C_f = 100pF$

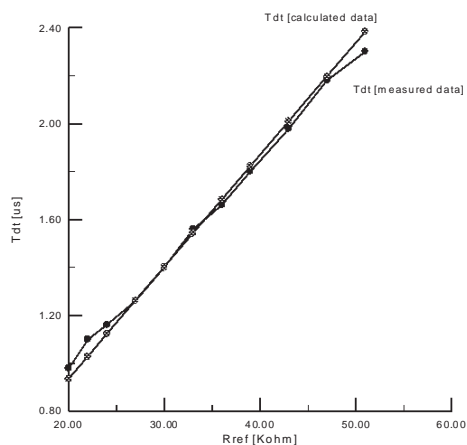

Figure 10. Frequency vs I_{RHV} @ $C_f=120pF$

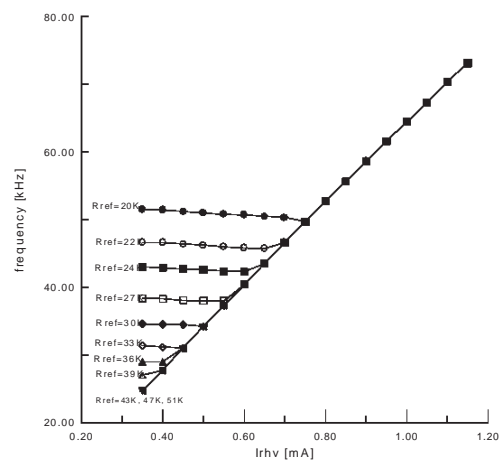

Figure 11. Frequency vs I_{RHV} @ $C_f = 150\text{pF}$

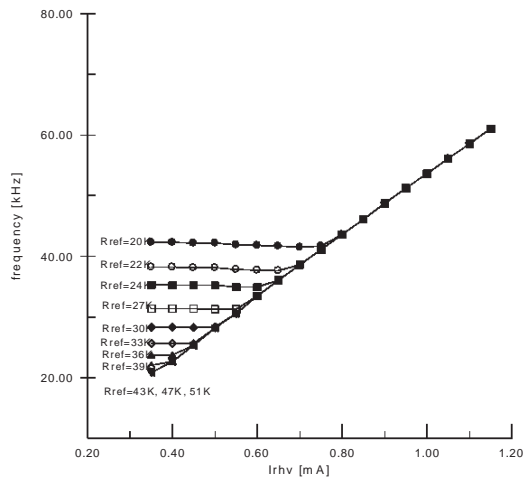

Figure 13. FEED FORWARD: measurements and calculations

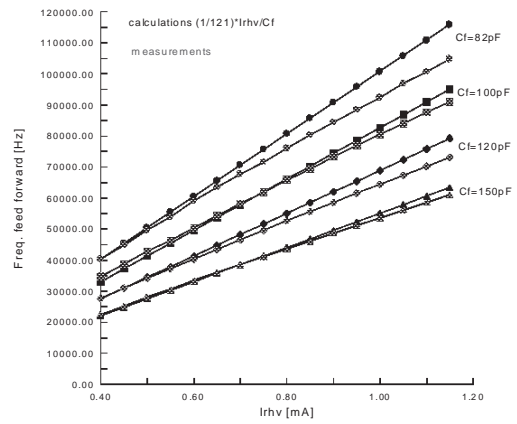
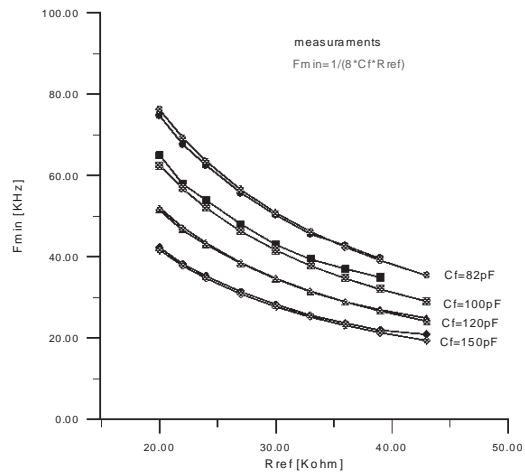
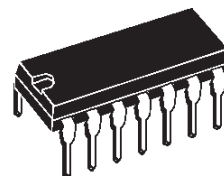

Figure 12. F_{MIN} : measurements and calculations



DIM.	mm			inch		
	MIN.	TYP.	MAX.	MIN.	TYP.	MAX.
a1	0.51			0.020		
B	1.39		1.65	0.055		0.065
b		0.5			0.020	
b1		0.25			0.010	
D			20			0.787
E		8.5			0.335	
e		2.54			0.100	
e3		15.24			0.600	
F			7.1			0.280
I			5.1			0.201
L		3.3			0.130	
Z	1.27		2.54	0.050		0.100

OUTLINE AND MECHANICAL DATA



DIP14

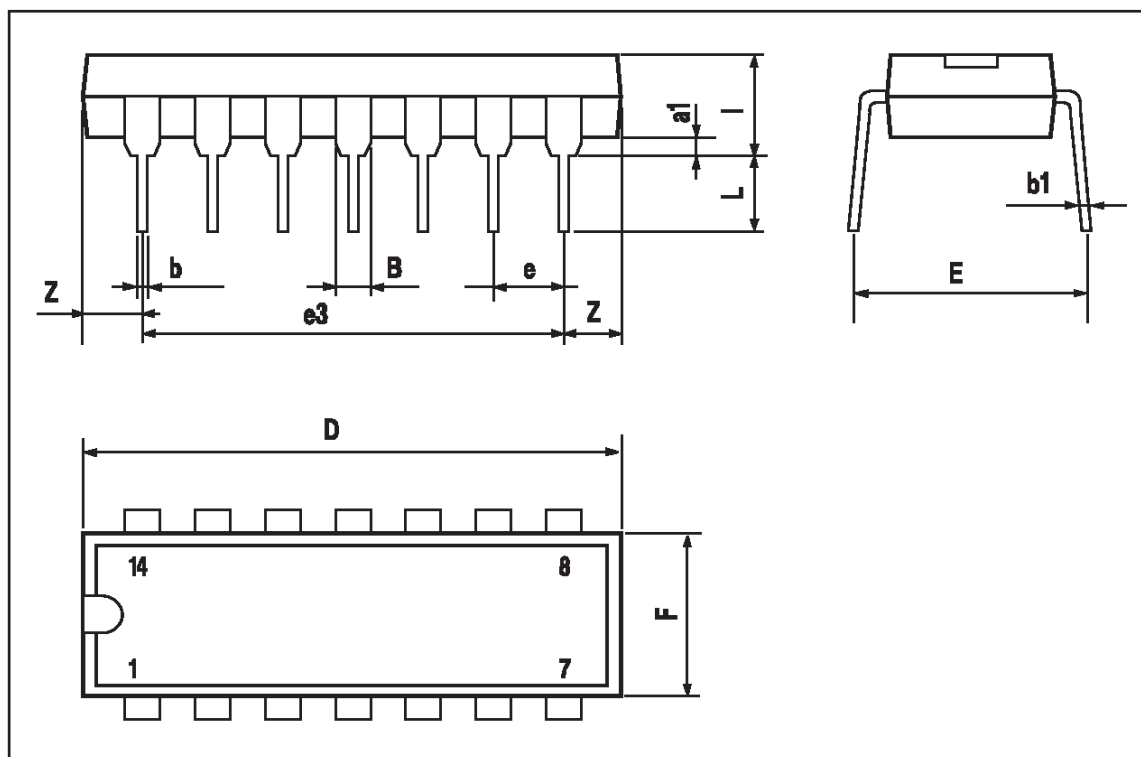

DIM.	mm			inch		
	MIN..	TYP.	MAX..	MIN..	TYP..	MAX..
A			1.75			0.069
a1	0.1		0.25	0.004		0.009
a2			1.6			0.063
b	0.35		0.46	0.014		0.018
b1	0.19		0.25	0.007		0.010
C		0.5			0.020	
c1	45° (typ.)					
D (1)	8.55		8.75	0.336		0.344
E	5.8		6.2	0.228		0.244
e		1.27			0.050	
e3		7.62			0.300	
F (1)	3.8		4	0.150		0.157
G	4.6		5.3	0.181		0.209
L	0.4		1.27	0.016		0.050
M			0.68			0.027
S	8° (max)					

OUTLINE AND MECHANICAL DATA

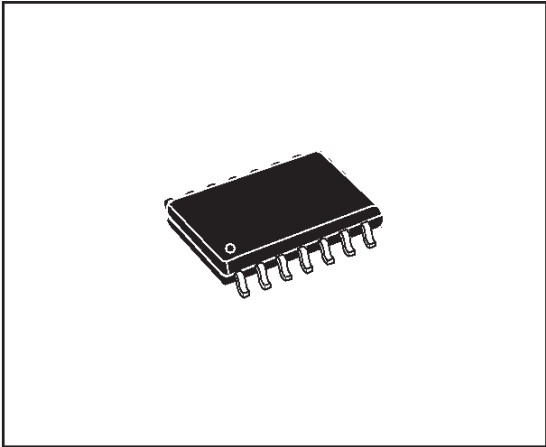

SO14

(1) D and F do not include mold flash or protrusions. Mold flash or protrusions shall not exceed 0.15mm (.006inch).

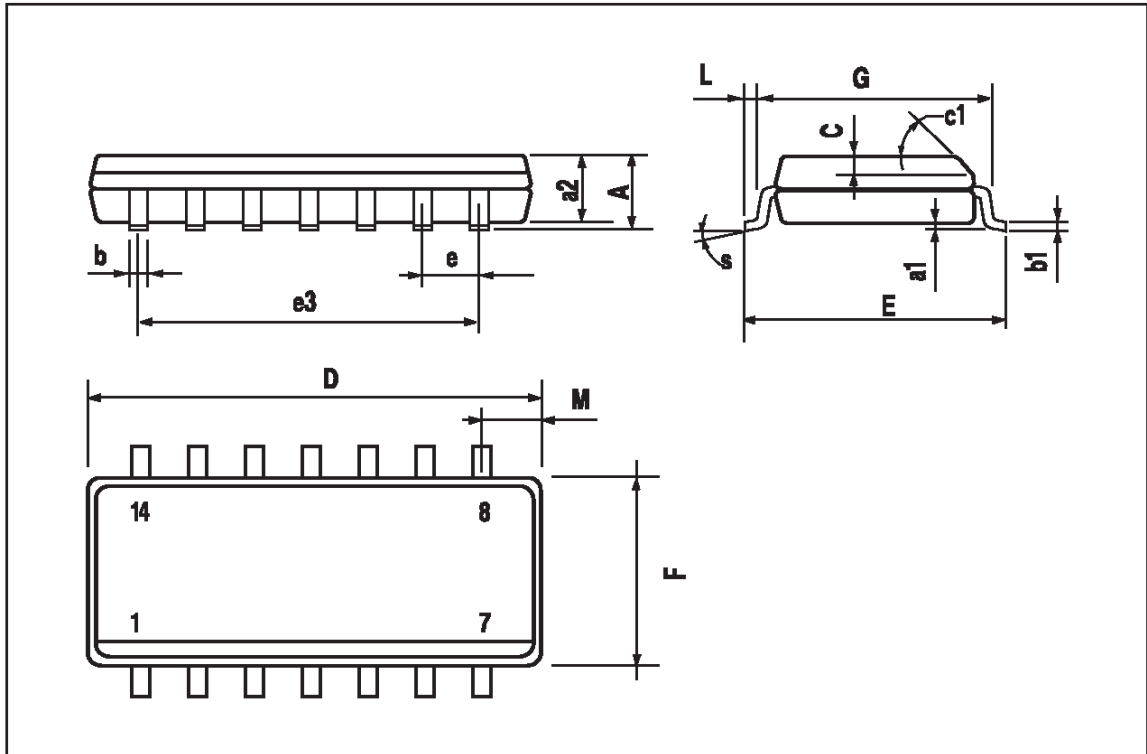

Information furnished is believed to be accurate and reliable. However, STMicroelectronics assumes no responsibility for the consequences of use of such information nor for any infringement of patents or other rights of third parties which may result from its use. No license is granted by implication or otherwise under any patent or patent rights of STMicroelectronics. Specifications mentioned in this publication are subject to change without notice. This publication supersedes and replaces all information previously supplied. STMicroelectronics products are not authorized for use as critical components in life support devices or systems without express written approval of STMicroelectronics.

The ST logo is a registered trademark of STMicroelectronics
® 1999 STMicroelectronics - All Rights Reserved

STMicroelectronics GROUP OF COMPANIES
Australia - Brazil - China - Finland - France - Germany - Hong Kong - India - Italy - Japan - Malaysia - Malta - Morocco - Singapore - Spain
- Sweden - Switzerland - United Kingdom - U.S.A.
<http://www.st.com>