

YMF289B

OPL3-L

OPL3 Low Voltage version

■ OVERVIEW

YMF289B (OPL3-L) is a synthesizer chip developed specially for note PC, PCMCIA (type II) card. YMF289B is compatible with YMF262 which is de facto standard in sound card market. Special functions (power down mode, 3.3V power supply and etc.) are newly featured.

■ FEATURES

- Register-compatible with YMF262
 1. Sound generation modes
 - Two-operator mode
Generates eighteen voices or fifteen voices plus five rhythm sounds simultaneously.
 - Four-operator mode
Generates six voices in four-operator mode plus six voices in two-operator mode, or generates six voices in four-operator mode plus three voices in two-operator mode plus five rhythm sounds simultaneously.
 2. Eight selectable waveforms
 3. Stereo output
- Sampling frequency is 44.1kHz.
- All registers are readable.
- Supports low power consumption mode (power down mode).
- 5V or 3.3V power supply.
- DAC interface compatible with YAC516 and YAC513.
- 44-pin QFP (YMF289B-F) or 48-pin SQFP (YMF289B-S) package.

■ PIN OUT DIAGRAM

● YMF289B-F

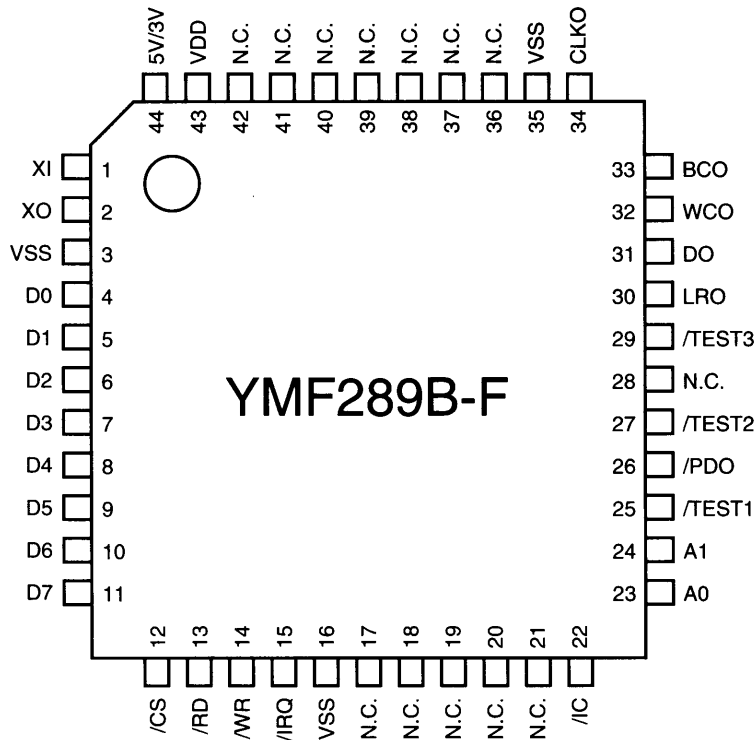

44 pin Top View

● YMF289B-S

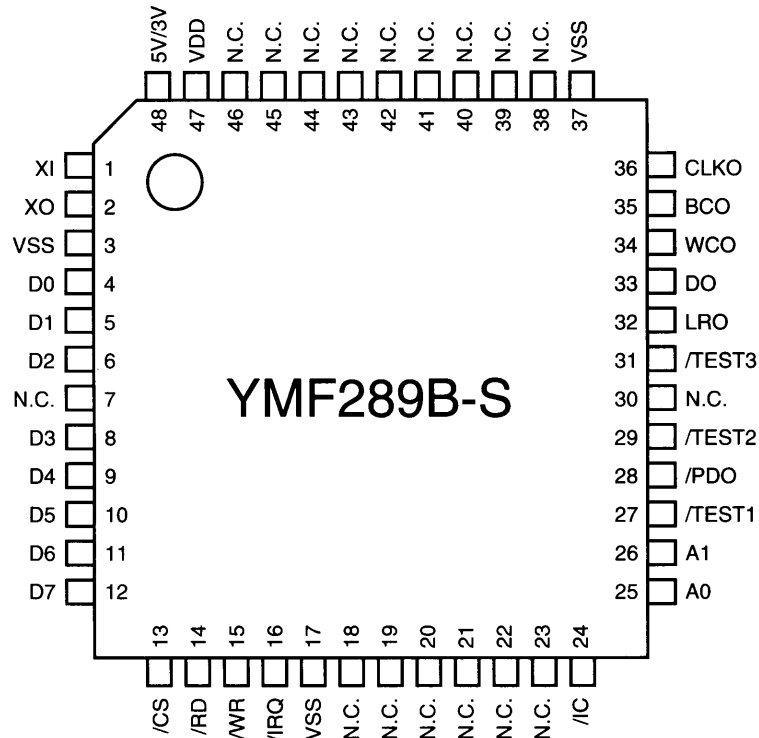

48 pin Top View

■ PIN DESCRIPTION

No.		I/O	Name	Function
44QFP	48SQFP			
1	1	I	XI	Crystal oscillator connection pin or master clock input (33.8688MHz)
2	2	O	XO	Crystal oscillator connection pin
3	3	-	VSS	Ground
4	4	I/O	D0	CPU interface: data 0
5	5	I/O	D1	CPU interface: data 1
6	6	I/O	D2	CPU interface: data 2
7	8	I/O	D3	CPU interface: data 3
8	9	I/O	D4	CPU interface: data 4
9	10	I/O	D5	CPU interface: data 5
10	11	I/O	D6	CPU interface: data 6
11	12	I/O	D7	CPU interface: data 7
12	13	I	/CS	CPU interface: chip select
13	14	I	/RD	CPU interface: read enable
14	15	I	/WR	CPU interface: write enable
15	16	OD	/IRQ	CPU interface: interrupt signal
16	17	-	VSS	Ground
22	24	I+	/IC	Initial clear input
23	25	I	A0	CPU interface: address 0
24	26	I	A1	CPU interface: address 1
25	27	I+	/TEST1	LSI test pin (Normally NC)
26	28	O	/PDO	Power down mode output
27	29	I+	/TEST2	LSI test pin (Normally NC)
29	31	I+	/TEST3	LSI test pin (Normally NC)
30	32	O	LRO	DAC interface: L/R clock output
31	33	O	DO	DAC interface: voice data output
32	34	O	WCO	DAC interface: word clock output
33	35	O	BCO	DAC interface: bit clock output
34	36	O	CLKO	Clock output pin (16.9344MHz)
35	37	-	VSS	Ground
43	47	-	VDD	+5V (or +3.3V) power supply
44	48	I	5V/3V	5V, 3.3V operation select (H: 5V, L:3.3V)

All pins other than the above are N.C. Normally do not connect them.

Note) I+: Input pin with pull up resistor
 OD: Open drain output pin

■ BLOCK DIAGRAM

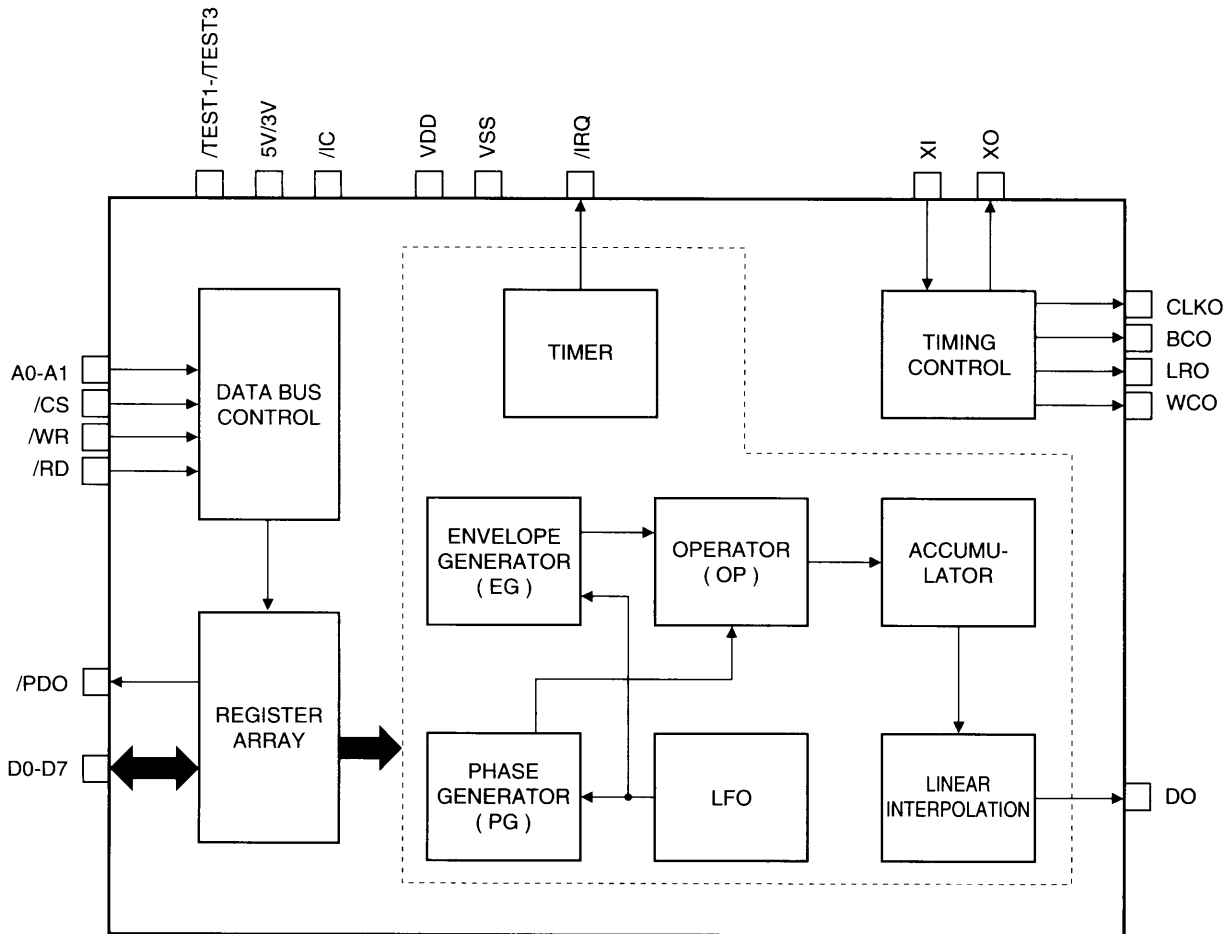

■ FUNCTION OVERVIEW

1. Master clock

The YMF289B synthesized frequency and envelope rate depend on the clock supplied from the XI pin. The YMF289B has a built-in self-oscillation circuit. Therefore, connect a 33.8688MHz (third overtone oscillation) crystal oscillator to the XI and XO pins as shown below.

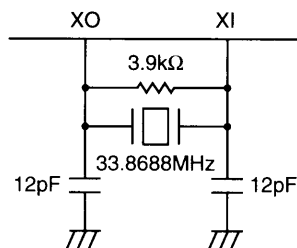

2. CPU interface

The FM performance, sound generation, and other functions of the YMF289B are controlled by writing data to the data registers described in “3. Register map”. Data is written to and read from the registers over the data bus (D0 to D7). The data bus is controlled by address signals A0 and A1 and control signals /CS, /WR, and /RD. These signals set the data bus mode as shown below.

/CS	/RD	/WR	A1	A0	Mode
H	X	X	X	X	Interactive mode
L	L	H	L	L	Status read mode
L	H	L	L/H	L	Address write mode
L	H	L	X	H	Data write mode
L	L	H	X	H	Data read mode

X: Don't care

2-1 Inactive Mode

When /CS is 'H', data bus (D0-D7) becomes high-impedance.

2-2 Status Read Mode

The Status Register can be read from D0-D7 in this mode.

2-3 Address Write Mode

In this mode data presented at D0-D7 will be latched as the register to be accessed. The A1 signal determines which register array is accessed: when A1 is 'L', register array 0 is selected: when A1 is 'H', register array 1 is selected.

<Caution>

Do not attempt to use the latched address until 56 (master clock) cycles have elapsed.

2-4 Data Write Mode

Data written to D0-D7 will go to the previously specified register. Successive writes to the same register can be made without refreshing the address.

<Caution>

Do not attempt to change the latched address or write new data until 56 (master clock) cycles have elapsed.

2-5 Data Read Mode

The previously specified register can be read from D0-D7 in this mode.

3. Register map

The YMF289B registers are made up of data registers, which control the LSI itself, and status registers, which show the status of the LSI.

Most of the data registers are compatible with the YMF262(OPL3). The YMF289B can read all the registers, even those not supported by the YMF262. However, the registers cannot be read in the power down mode. Initialization (/IC="L") clears all the registers.

3-1 Data registers

ADDRESS (HEX)	REGISTER ARRAY 0 (A1='L')								REGISTER ARRAY 1 (A1='H')									
	D7	D6	D5	D4	D3	D2	D1	D0	D7	D6	D5	D4	D3	D2	D1	D0		
00H~01H	LSI TEST								LSI TEST									
02H	TIMER 1																	
03H	TIMER 2																	
04H	RST	MT1	MT2					ST2	ST1	CONNECTION SEL								
05H									NEW3 ★ NEW									
08H	NTS								CLR			PD1	PD0					
20H~35H	AM	VIB	EGT	KSR	MULT 3 2 1 0				AM	VIB	EGT	KSR	MULT 3 2 1 0					
40H~55H	KSL 1 0		TL 5 4 3 2 1 0						KSL 1 0		TL 5 4 3 2 1 0							
60H~75H	AR 3 2 1 0				DR 3 2 1 0				AR 3 2 1 0				DR 3 2 1 0					
80H~95H	SL 3 2 1 0				RR 3 2 1 0				SL 3 2 1 0				RR 3 2 1 0					
A0H~A8H	F-NUMBER (L) F7 F6 F5 F4 F3 F2 F1 F0								F-NUMBER (L) F7 F6 F5 F4 F3 F2 F1 F0									
B0H~B8H			KON	BLOCK B2 B1 B0			F-NUM (H) F9 F8					KON	BLOCK B2 B1 B0			F-NUM (H) F9 F8		
BDH	DAM	DVB	RHY	BD	SD	TOM	TC	HH										
C0H~C8H	★	★	CHR	CHL	FB FB2 FB1 FB0			CNT	★	★	CHR	CHL	FB FB2 FB1 FB0			CNT		
E0H~F5H					WS W2 W1 W0								WS W2 W1 W0					

Notes)

- The register map is basically the same as that of the YMF262 except for the following:
 - The NEW3, PD0, PD1, and CLR bits of registers 05H and 08H of REGISTER ARRAY 1 are newly defined.
 - Bits D6 and D7 of registers C0 to C8H of register arrays 0 and 1 are not supported .
- The LSI TEST registers are used for factory testing. Always set them to "0" during normal operation.
- not used by the YMF289B may be used to expand the functions. Always set them to "0".
- Bits indicated by ★ can be read, but are not supported functionally.

3.2 Status register

ADDRESS (HEX)	STATUS REGISTER							
	D7	D6	D5	D4	D3	D2	D1	D0
xx	IRQ	FT1	FT2			BUSY		BUSY

YMF289B identification

When the status is read after initialization, the YM3812(OPL2) outputs 06H and the YMF262 outputs 00H.

The YMF289B outputs the same value as the YMF262, but since it can read all the data registers, it can be discriminated from the YMF262 by whether or not all the data registers can be read.

4. DAC interface

The YMF289B outputs the voice data as digital data. Therefore, an external D/A converter is necessary. The digital data is output MSB-first from the DO pin as 2's complement data. The sampling frequency is 44.1kHz. The relationship between the DO pin digital data and the control signals (BCO, WCO, LRO) is shown below.

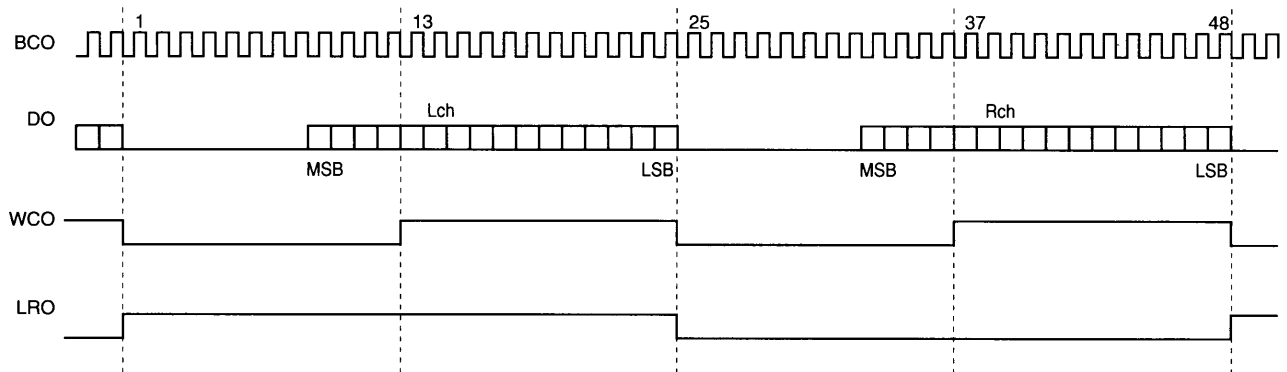

BCO: 48fs duty 50%

WCO: 2fs duty 50%

LRO: 1fs duty 50%

5. Additional functions

The YMF289B has the following additional functions, as compared to the YMF262.

5-1 NEW3 bit

This bit enables the newly defined bits (PD0 bit, PD1 bit, CLR bit, BUSY flag). When this bit is "1", the bits above are enabled.

5-2 PD0, PD1 bits

These bits set the power down mode. Always set and reset the power down mode in the following order:

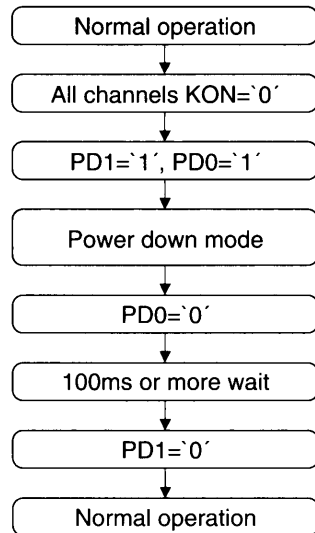

Power down mode

In the power down mode, clock oscillation is completely stopped and there is much lower power consumption than during normal operation. At this time, synthesizing stops, but the registers retain their contents before the YMF289B enters the power down mode.

In the power down mode, all the DAC interface pins (CLKO, LRO, WCO, BCO, DO) are fixed at the “L” level and the /IRQ pin retains its state before the YMF289B enters the power down mode. Be sure to fix the input pins (including D0 to D7) at the “H” or “L” level.

<Caution>

If KON=“1” when the machine returns from the power down mode, unexpected sound may be generated. Therefore, before switching to the power down mode, set all channels to KON=“0”. As for the timer, when the machine returns from the power down mode, RST becomes “1” and the counter is reset.

5-3 CLR bit

This bit clears all the data register bits except NEW and NEW3. CLR=“1” clears the data registers and CLR=“0” resets the data registers. The time required to clear the data registers is 90μs (3000 cycles @ 33.8688MHz).

5-4 BUSY flag

This flag inhibits register access. It remains “1” until the data bus data is latched as an address, or is verified as register data.

5-5 /PDO pin

This bit becomes “L” when the YMF289B shifted to the power down mode. When the YMF289B returns to normal operation, this bit becomes “H”. Use this bit to control a YAC516 or other YMF289B peripheral LSI.

■ ELECTRICAL CHARACTERISTICS

1. Absolute maximum ratings

Item	Symbol	Rated value	Unit
Power supply voltage	V _{DD}	-0.3~7.0	V
Input voltage	V _{IN}	-0.3~V _{DD} +0.5	V
Operation temperature	T _{OP}	0~70	°C
Storage temperature	T _{STG}	-50~125	°C

2. Recommended operating conditions

Item	Symbol	Condition	Min.	Typ.	Max.	Unit
Power supply voltage	V _{DD}	5V/3V="H"	4.75	5.00	5.25	V
	V _{DD}	5V/3V="L"	3.00	3.30	3.60	V
Operating temperature	T _{OP}		0	25	70	°C

3. DC characteristics

*At recommended operating conditions.

Item	Symbol	Condition	Min.	Max.	Unit
Power consumption	P _D	V _{DD} =5.0V, *1	-	150	mW
		V _{DD} =3.3V, *1	-	60	mW
		V _{DD} =5.0V, *2	-	300	μW
		V _{DD} =3.3V, *2	-	200	μW
Input high level voltage (1)	V _{IH1}	*3	2.0	-	V
Input low level voltage (1)	V _{IL1}	*3	-	0.8	V
Input high level voltage (2)	V _{IH2}	*4	0.7V _{DD}	-	V
Input low level voltage (2)	V _{IL2}	*4	-	0.2V _{DD}	V
Input leakage current	I _{LI}	*5	-10	10	μA
Input capacitance	C _I		-	10	pF
Output high level voltage (1)	V _{OH1}	I _{OH} =-80 [μA], *6	V _{DD} -1.0	-	V
Output low level voltage (1)	V _{OL1}	I _{OL} =2 [mA], *6	-	V _{SS} +0.4	V
Output high level voltage (2)	V _{OH2}	I _{OH} =-80 [μA], *7	2.4	-	V
Output low level voltage (2)	V _{OL2}	I _{OL} =2 [mA], *7	-	0.4	V
Output low level voltage (3)	V _{OL3}	I _{OL} =2 [mA], *8	-	0.4	V
Output capacitance	C _O		-	10	pF
Pull-up resistance	R _U	*9	50	400	kΩ

Notes) *1: f_{M1}=33.8688MHz, normal operation

*2: Power down mode

*3: Applies to /TEST1 to TEST3, /IC, /WR/, /RD, /CS, A0 to A1, and D0 to D7.

*4: Applies to XI and 5V/3V.

*5: V_{IN}=0-5V. Applies to /WR, /RD, /CS, A0 to A1, D0 to D7, XI, and 5V/3V.

*6: 5V/3V="H". Applies to D0 to D7 (at output), /PDO, CLK0, BCO, LRO, WCO, and DO.

*7: 5V/3V="L". Applies to D0 to D7 (at output), /PDO, CLK0, BCO, LRO, WCO, and DO.

*8: Applies to /IRQ pin.

*9: Applies to /IC, and /TEST1 to /TEST3.

4. AC characteristics

*At recommended operating conditions.

Item	Symbol	Fig.	Min.	Typ.	Max.	Unit
Master clock frequency	f _{M1}	Fig. 1	-	33.8688	-	MHz
Duty 1	D1		40	50	60	%
Output master clock frequency	f _{M2}	Fig. 2	-	16.9344	-	MHz
Duty 2	D2		-	50	-	%
Reset pulse width	t _{ICW}	Fig. 3	3000/f _{M1}	-	-	s
Address setup time	t _{AS}	Figs. 4, 5	30	-	-	ns
Address hold time	t _{AH}	Figs. 4, 5	10	-	-	ns
Chip select setup time	t _{CSS}	Figs. 4, 5	5	-	-	ns
Chip select hold time	t _{CSH}	Figs. 4, 5	10	-	-	ns
Write pulse width	t _{WW}	Fig. 4	50	-	-	ns
Write data setup time	t _{WDS}	Fig. 4	10	-	-	ns
Write data hold time	t _{WDH}	Fig. 4	10	-	-	ns
Read pulse width	t _{RW}	Fig. 5	80	-	-	ns
Read data access time	t _{ACC}	Fig. 5	-	-	60	ns
Read data hold time	t _{RDH}	Fig. 5	10	-	-	ns
Bit clock frequency	f _{BC}	Fig. 6	-	48fs	-	MHz
Bit clock high level time	t _{CH}	Fig. 6	110	-	-	ns
Data out setup time	t _{DOS}	Fig. 6	100	-	-	ns
Data out hold time	t _{DOH}	Fig. 6	280	-	-	ns
LR clock setup time	t _{LRs}	Fig. 6	100	-	-	ns
LR clock hold time	t _{LRH}	Fig. 6	280	-	-	ns
Word clock hold time	t _{WCH}	Fig. 6	280	-	-	ns

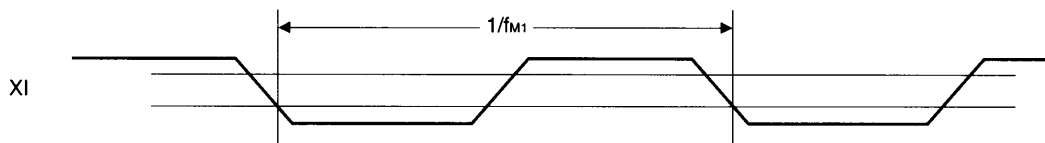

Fig. 1 Input Clock timing

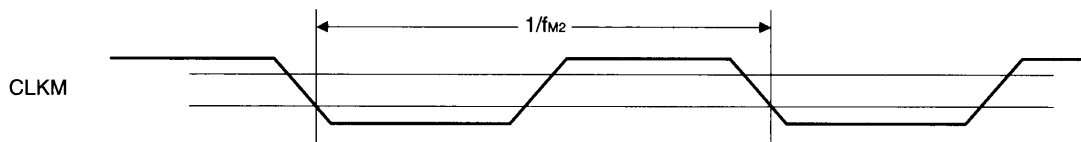

Fig. 2 Output Clock Timing

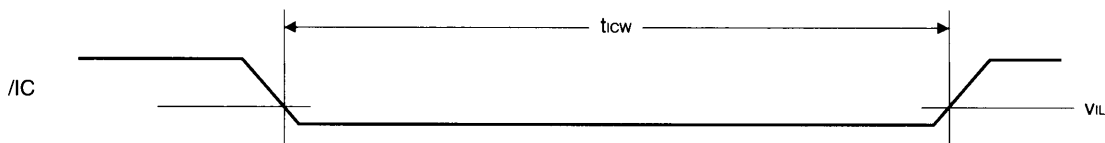

Fig. 3 Setup Pulse Width

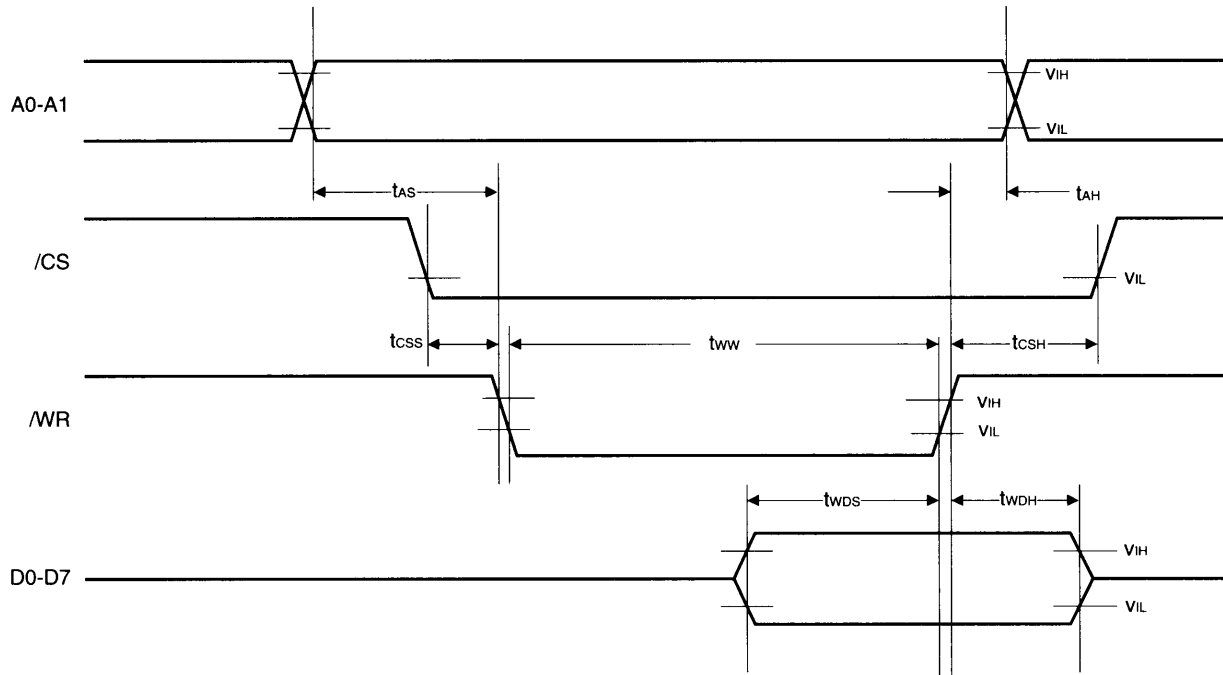

Fig. 4 CPU Write Timing

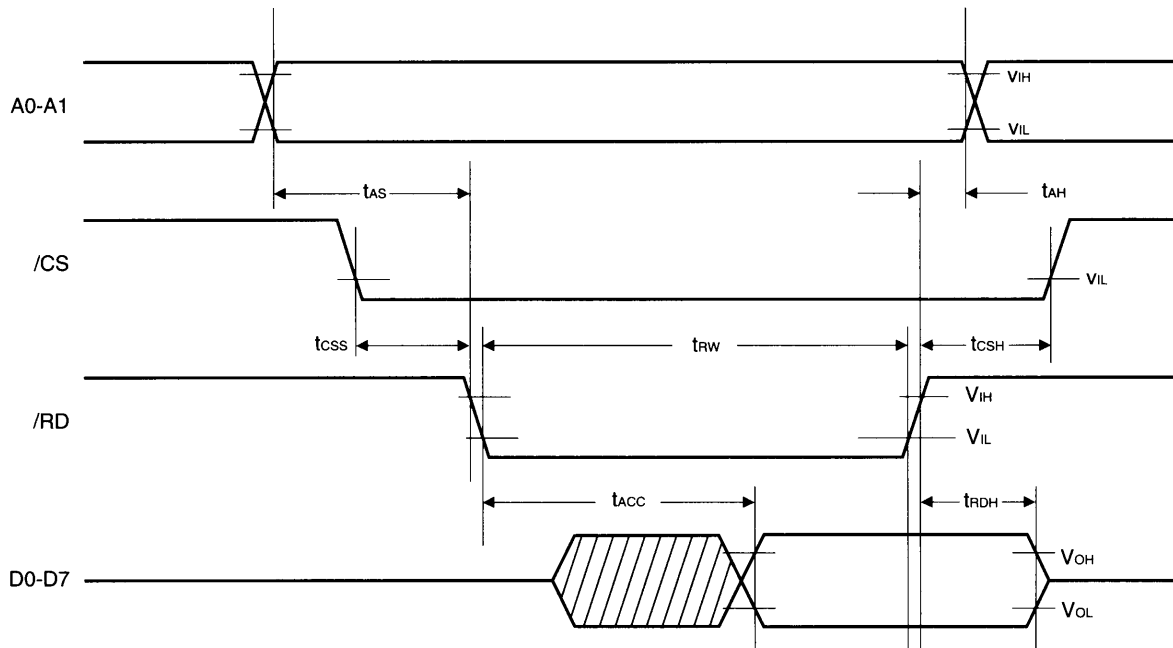

Fig. 5 CPU Read Timing

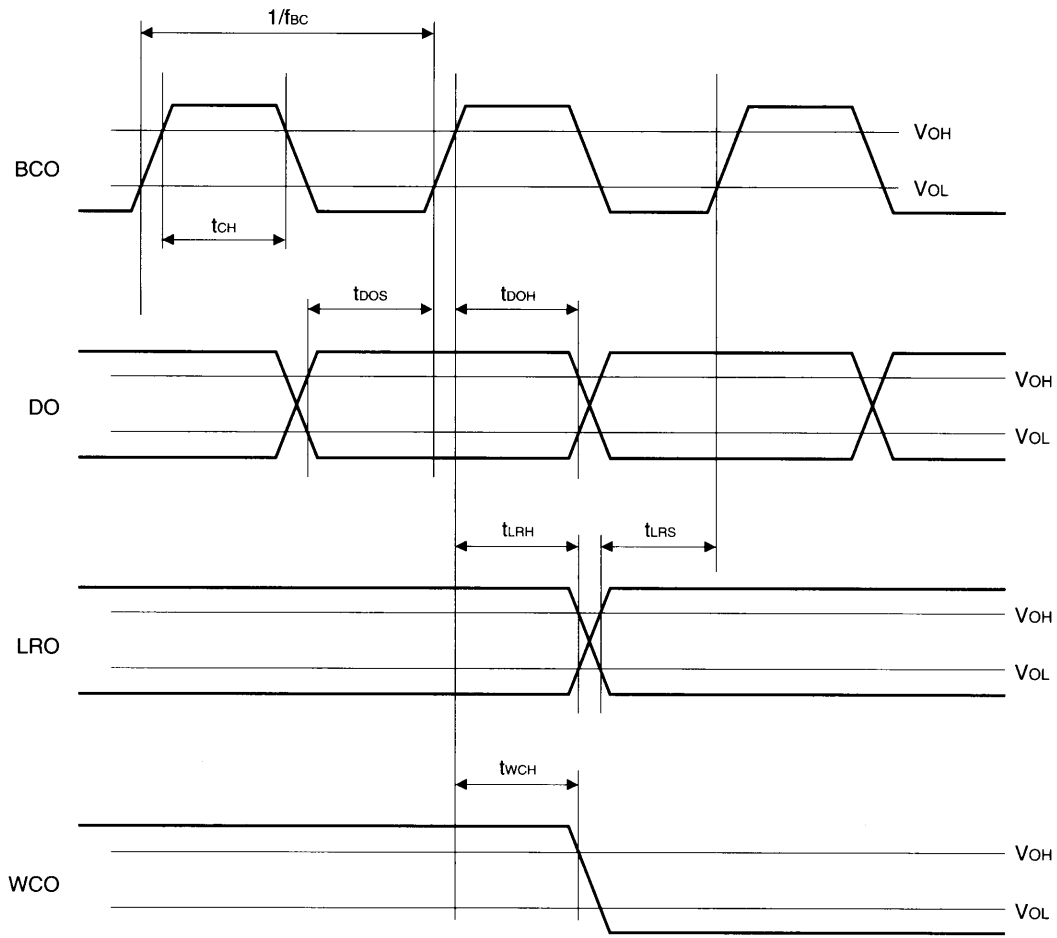
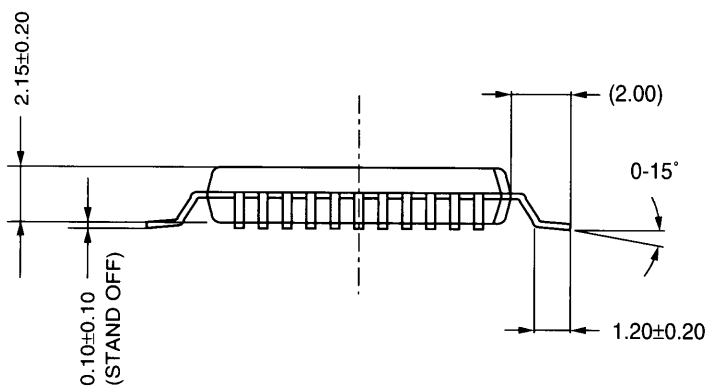
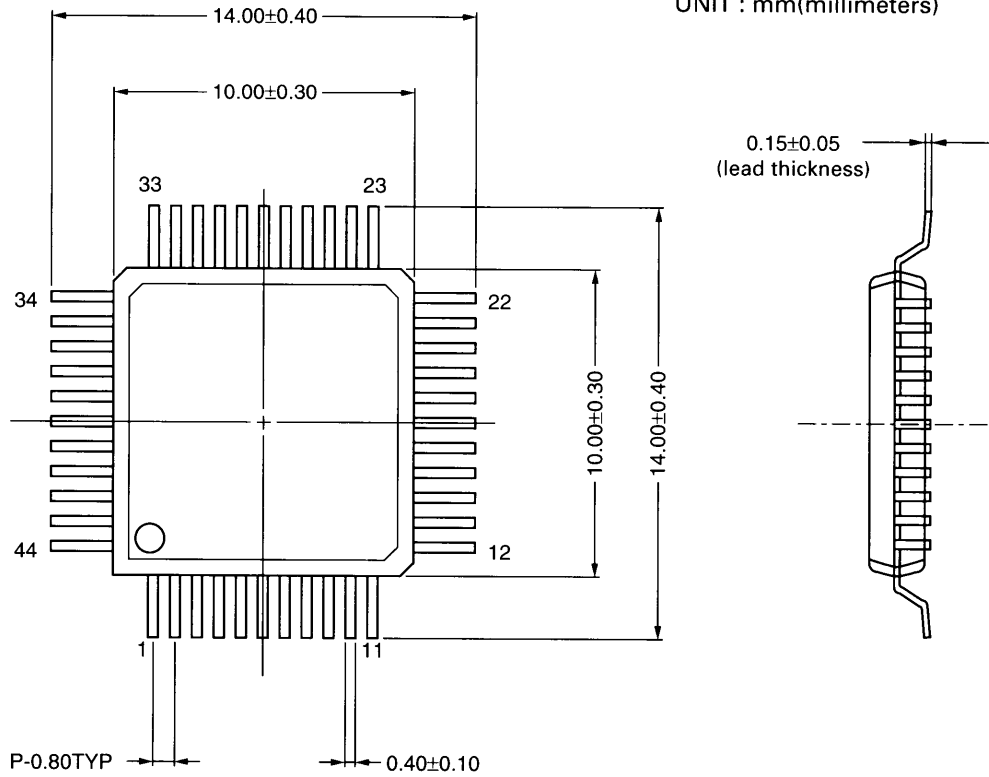

Fig. 6 DAC Interface Timing

EXTERNAL DIMENSIONS

- YMF289B-F (44QFP)

UNIT : mm(millimeters)



• YMF289B-S (48SQFP)

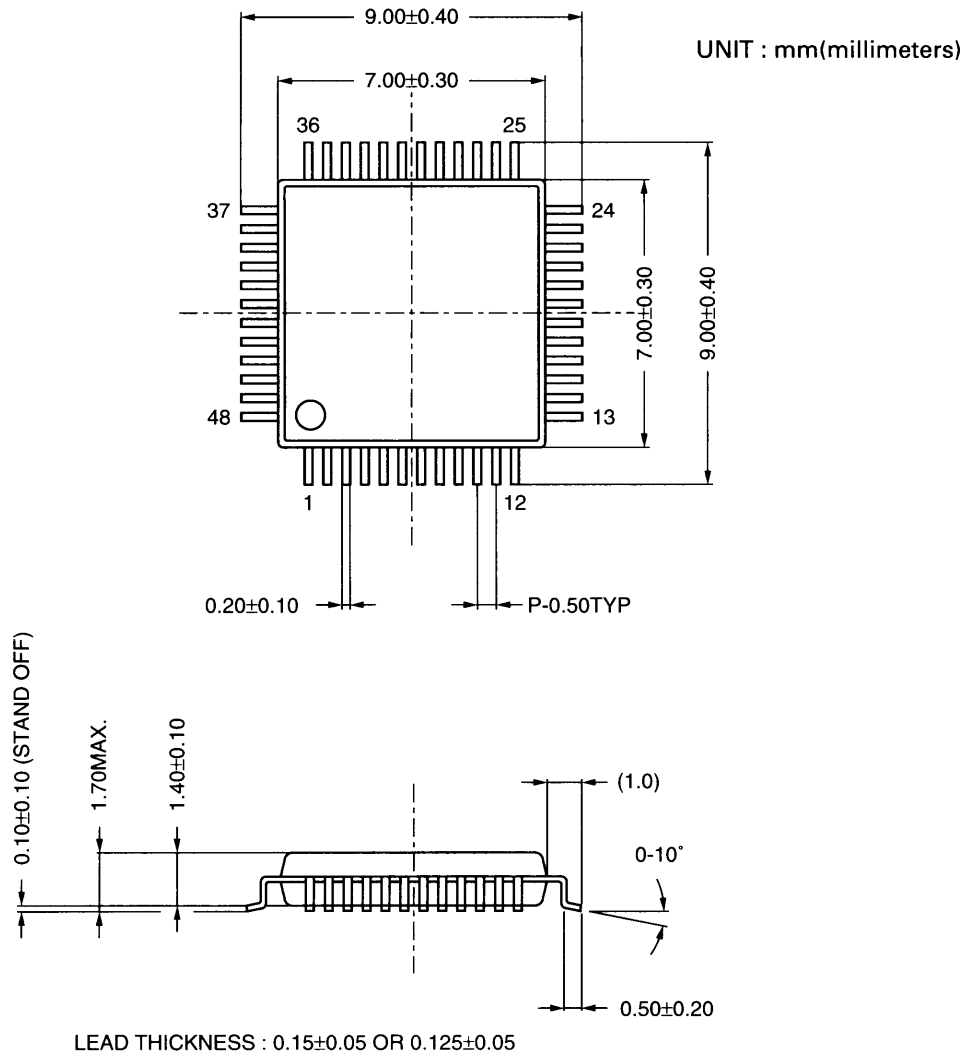

IMPORTANT NOTICE

1. Yamaha reserves the right to make changes to its Products and to this document without notice. The information contained in this document has been carefully checked and is believed to be reliable. However, Yamaha assumes no responsibilities for inaccuracies and makes no commitment to update or to keep current the information contained in this document.
2. These Yamaha Products are designed only for commercial and normal industrial applications, and are not suitable for other uses, such as medical life support equipment, nuclear facilities, critical care equipment or any other application the failure of which could lead to death, personal injury or environmental or property damage. Use of the Products in any such application is at the customer's sole risk and expense.
3. YAMAHA ASSUMES NO LIABILITY FOR INCIDENTAL, CONSEQUENTIAL OR SPECIAL DAMAGES OR INJURY THAT MAY RESULT FROM MISAPPLICATION OR IMPROPER USE OR OPERATION OF THE PRODUCTS.
4. YAMAHA MAKES NO WARRANTY OR REPRESENTATION THAT THE PRODUCTS ARE SUBJECT TO INTELLECTUAL PROPERTY LICENSE FROM YAMAHA OR ANYTHIRD PARTY, AND YAMAHA MAKES NO WARRANTY OR REPRESENTATION OF NON-INFRINGEMENT WITH RESPECT TO THE PRODUCTS. YAMAHA SPECIFICALLY EXCLUDES ANY LIABILITY TO THE CUSTOMER OR ANY THIRD PARTY ARISING FROM OR RELATED TO THE PRODUCTS' INFRINGEMENT OF ANY THIRD PARTY'S INTELLECTUAL PROPERTY RIGHTS, INCLUDING THE PATENT, COPYRIGHT, TRADEMARK OR TRADE SECRET RIGHTS OF ANY THIRD PARTY.
5. EXAMPLES OF USE DESCRIBED HEREIN ARE MERELY TO INDICATE THE CHARACTERISTICS AND PERFORMANCE OF YAMAHA PRODUCTS. YAMAHA ASSUMES NO RESPONSIBILITY FOR ANY INTELLECTUAL PROPERTY CLAIMS OR OTHER PROBLEMS THAT MAY RESULT FROM APPLICATIONS BASED ON THE EXAMPLES DESCRIBED HEREIN. YAMAHA MAKES NO WARRANTY WITH RESPECT TO THE PRODUCTS, EXPRESS OR IMPLIED, INCLUDING, BUT NOT LIMITED TO THE WARRANTIES OF MERCHANTABILITY, FITNESS FOR A PARTICULAR USE AND TITLE.

_____ AGENCY _____

YAMAHA CORPORATION

Address inquiries to :
Semiconductor Sales & Marketing Department

- Head Office 203, Matsunokijima, Toyooka-mura,
Iwata-gun, Shizuoka-ken, 438-0192
Tel. +81-539-62-4918 Fax. +81-539-62-5054
- Tokyo Office 2-17-11, Takanawa, Minato-ku,
Tokyo, 108-8568
Tel. +81-3-5488-5431 Fax. +81-3-5488-5088
- Osaka Office Namba Tsujimoto Nissei Bldg, 4F
1-13-17, Namba Naka, Naniwa-ku,
Osaka City, Osaka, 556-0011
Tel. +81-6-6633-3690 Fax. +81-6-6633-3691
- U.S.A Office YAMAHA Systems Technology.
100 Century Center Court, San Jose, CA 95112
Tel. +1-408-467-2300 Fax. +1-408-437-8791