

OKI Semiconductor

MSM5118165D/DSL

1,048,576-Word × 16-Bit DYNAMIC RAM : FAST PAGE MODE TYPE WITH EDO

DESCRIPTION

The MSM5118165D/DSL is a 1,048,576-word × 16-bit dynamic RAM fabricated in Oki's silicon-gate CMOS technology. The MSM5118165D/DSL achieves high integration, high-speed operation, and low-power consumption because Oki manufactures the device in a quadruple-layer polysilicon/double-layer metal CMOS process. The MSM5118165D/DSL is available in a 42-pin plastic SOJ or 50/44-pin plastic TSOP. The MSM5118165DSL (the self-refresh version) is specially designed for lower-power applications.

FEATURES

- 1,048,576-word × 16-bit configuration
 - Single 5 V power supply, ±10% tolerance
 - Input : TTL compatible, low input capacitance
 - Output : TTL compatible, 3-state
 - Refresh : 1024 cycles/16 ms, 1024 cycles/128 ms (SL version)
 - Fast page mode with EDO, read modify write capability
 - $\overline{\text{CAS}}$ before $\overline{\text{RAS}}$ refresh, hidden refresh, $\overline{\text{RAS}}$ -only refresh capability
 - $\overline{\text{CAS}}$ before $\overline{\text{RAS}}$ self-refresh capability (SL version)
 - Package options:
 - 42-pin 400 mil plastic SOJ (SOJ42-P-400-1.27) (Product : MSM5118165D/DSL-xxJS)
 - 50/44-pin 400 mil plastic TSOP (TSOP1150/44-P-400-0.80-K)(Product : MSM5118165D/DSL-xxTS-K)
 - (TSOP1150/44-P-400-0.80-L) (Product : MSM5118165D/DSL-xxTS-L)
- xx indicates speed rank.

PRODUCT FAMILY

Family	Access Time (Max.)				Cycle Time (Min.)	Power Dissipation	
	t _{RAC}	t _{AA}	t _{CAC}	t _{OEa}		Operating (Max.)	Standby (Max.)
MSM5118165D/DSL-50	50 ns	25 ns	13 ns	13 ns	84 ns	743 mW	5.5 mW/ 1.1 mW (SL version)
MSM5118165D/DSL-60	60 ns	30 ns	15 ns	15 ns	104 ns	688 mW	
MSM5118165D/DSL-70	70 ns	35 ns	20 ns	20 ns	124 ns	633 mW	

PIN CONFIGURATION (TOP VIEW)

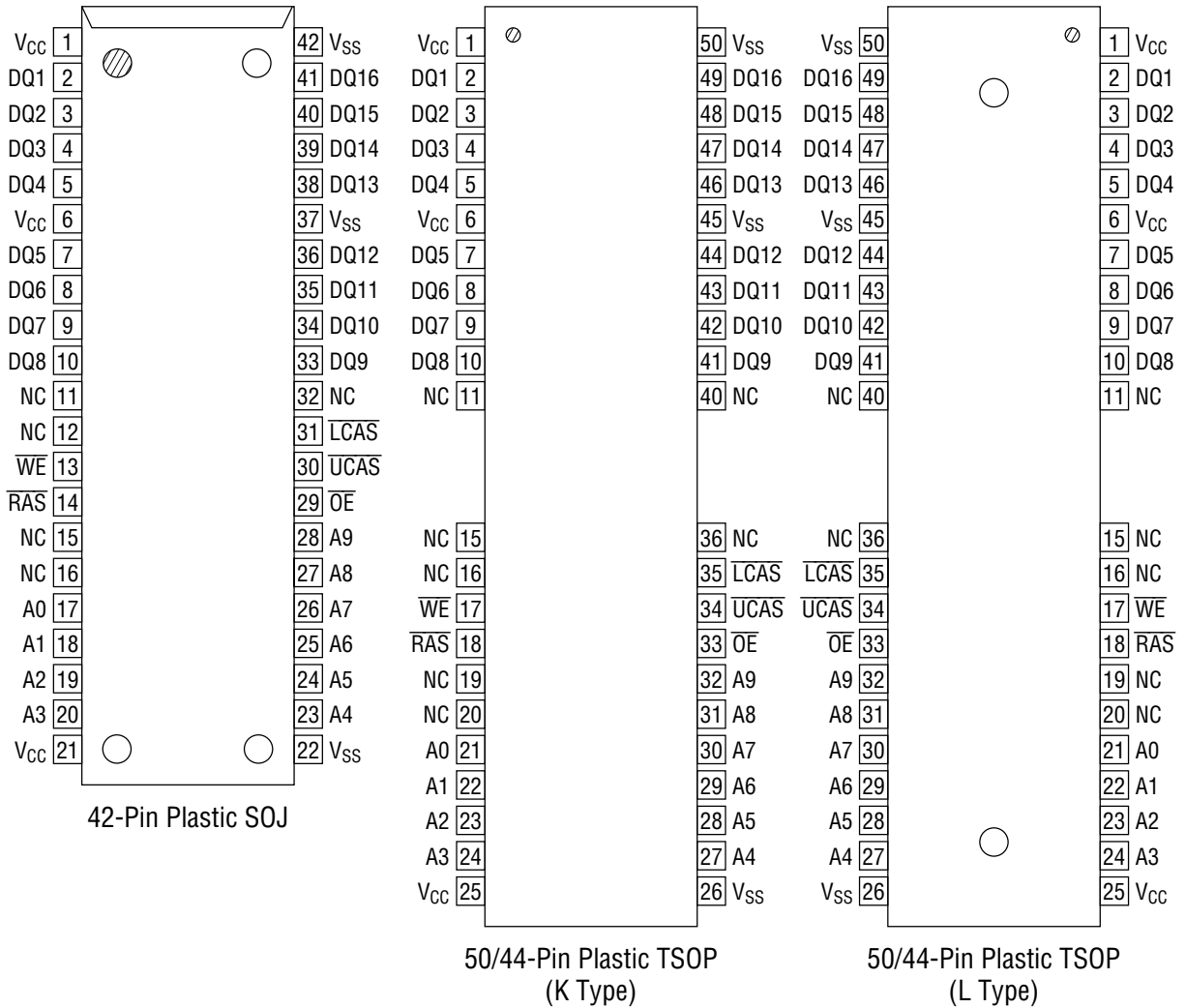

Pin Name	Function
A0 - A9	Address Input
RAS	Row Address Strobe
LCAS	Lower Byte Column Address Strobe
UCAS	Upper Byte Column Address Strobe
DQ1 - DQ16	Data Input/Data Output
OE	Output Enable
WE	Write Enable
V _{CC}	Power Supply (5 V)
V _{SS}	Ground (0 V)
NC	No Connection

Note : The same power supply voltage must be provided to every V_{CC} pin, and the same GND voltage level must be provided to every V_{SS} pin.

BLOCK DIAGRAM

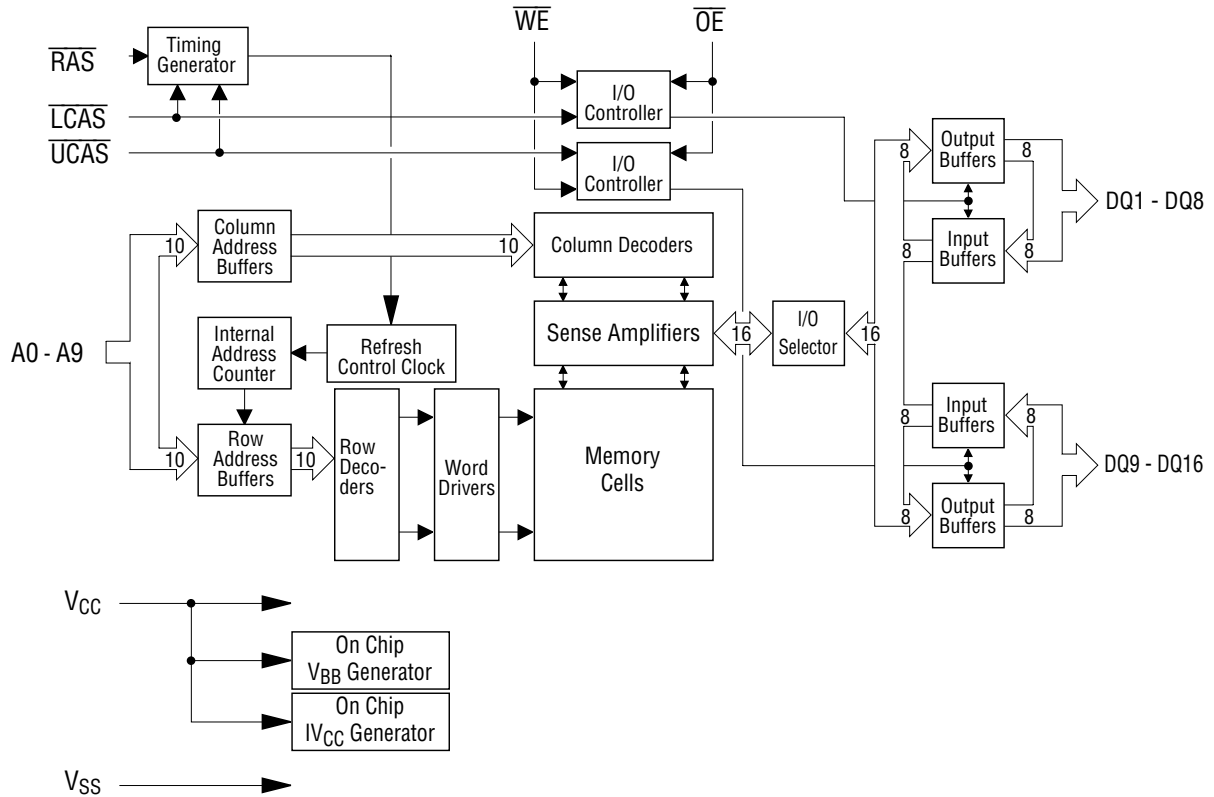

FUNCTION TABLE

Input Pin					DQ Pin		Function Mode
$\overline{\text{RAS}}$	$\overline{\text{LCAS}}$	$\overline{\text{UCAS}}$	$\overline{\text{WE}}$	$\overline{\text{OE}}$	DQ1 - DQ8	DQ9 - DQ16	
H	*	*	*	*	High-Z	High-Z	Standby
L	H	H	*	*	High-Z	High-Z	Refresh
L	L	H	H	L	D _{OUT}	High-Z	Lower Byte Read
L	H	L	H	L	High-Z	D _{OUT}	Upper Byte Read
L	L	L	H	L	D _{OUT}	D _{OUT}	Word Read
L	L	H	L	H	D _{IN}	Don't Care	Lower Byte Write
L	H	L	L	H	Don't Care	D _{IN}	Upper Byte Write
L	L	L	L	H	D _{IN}	D _{IN}	Word Write
L	L	L	H	H	High-Z	High-Z	—

*: "H" or "L"

ELECTRICAL CHARACTERISTICS

Absolute Maximum Ratings

Parameter	Symbol	Rating	Unit
Voltage on Any Pin Relative to V_{SS}	V_{IN}, V_{OUT}	-0.5 to $V_{CC} + 0.5$	V
Voltage on V_{CC} Supply Relative to V_{SS}	V_{CC}	-0.5 to 7	V
Short Circuit Output Current	I_{OS}	50	mA
Power Dissipation	P_D^*	1	W
Operating Temperature	T_{opr}	0 to 70	°C
Storage Temperature	T_{stg}	-55 to 150	°C

*: $T_a = 25^\circ\text{C}$

Recommended Operating Conditions

($T_a = 0^\circ\text{C}$ to 70°C)

Parameter	Symbol	Min.	Typ.	Max.	Unit
Power Supply Voltage	V_{CC}	4.5	5.0	5.5	V
	V_{SS}	0	0	0	V
Input High Voltage	V_{IH}	2.4	—	$V_{CC} + 0.5^{*1}$	V
Input Low Voltage	V_{IL}	-0.5^{*2}	—	0.8	V

Notes : *1. The input voltage is $V_{CC} + 2.0\text{V}$ when the pulse width is less than 20 ns (the pulse width is with respect to the point at which V_{CC} is applied).

*2. The input voltage is $V_{SS} - 2.0\text{V}$ when the pulse width is less than 20 ns (the pulse width is with respect to the point at which V_{SS} is applied).

Capacitance

($V_{CC} = 5\text{V} \pm 10\%$, $T_a = 25^\circ\text{C}$, $f = 1\text{MHz}$)

Parameter	Symbol	Typ.	Max.	Unit
Input Capacitance (A0 - A9)	C_{IN1}	—	5	pF
Input Capacitance (RAS, LCAS, UCAS, WE, OE)	C_{IN2}	—	7	pF
Output Capacitance (DQ1 - DQ16)	$C_{I/O}$	—	7	pF

DC Characteristics

(V_{CC} = 5 V ±10%, T_a = 0°C to 70°C)

Parameter	Symbol	Condition	MSM5118165 D/DSL-50		MSM5118165 D/DSL-60		MSM5118165 D/DSL-70		Unit	Note
			Min.	Max.	Min.	Max.	Min.	Max.		
Output High Voltage	V _{OH}	I _{OH} = -5.0 mA	2.4	V _{CC}	2.4	V _{CC}	2.4	V _{CC}	V	
Output Low Voltage	V _{OL}	I _{OL} = 4.2 mA	0	0.4	0	0.4	0	0.4	V	
Input Leakage Current	I _{LI}	0 V ≤ V _I ≤ 6.5 V; All other pins not under test = 0 V	-10	10	-10	10	-10	10	μA	
Output Leakage Current	I _{LO}	DQ disable 0 V ≤ V _O ≤ V _{CC}	-10	10	-10	10	-10	10	μA	
Average Power Supply Current (Operating)	I _{CC1}	$\overline{\text{RAS}}$, $\overline{\text{CAS}}$ cycling, t _{RC} = Min.	—	135	—	125	—	115	mA	1, 2
Power Supply Current (Standby)	I _{CC2}	$\overline{\text{RAS}}$, $\overline{\text{CAS}}$ = V _{IH}	—	2	—	2	—	2	mA	1
		$\overline{\text{RAS}}$, $\overline{\text{CAS}}$ ≥ V _{CC} - 0.2 V	—	200	—	200	—	200	μA	1, 5
Average Power Supply Current ($\overline{\text{RAS}}$ -only Refresh)	I _{CC3}	$\overline{\text{RAS}}$ cycling, $\overline{\text{CAS}}$ = V _{IH} , t _{RC} = Min.	—	135	—	125	—	115	mA	1, 2
Power Supply Current (Standby)	I _{CC5}	$\overline{\text{RAS}}$ = V _{IH} , $\overline{\text{CAS}}$ = V _{IL} , DQ = enable	—	5	—	5	—	5	mA	1
Average Power Supply Current ($\overline{\text{CAS}}$ before $\overline{\text{RAS}}$ Refresh)	I _{CC6}	$\overline{\text{RAS}}$ cycling, $\overline{\text{CAS}}$ before $\overline{\text{RAS}}$	—	135	—	125	—	115	mA	1, 2
Average Power Supply Current (Fast Page Mode)	I _{CC7}	$\overline{\text{RAS}}$ = V _{IL} , $\overline{\text{CAS}}$ cycling, t _{HPC} = Min.	—	135	—	125	—	115	mA	1, 3
Average Power Supply Current (Battery Backup)	I _{CC10}	t _{RC} = 125 μs, $\overline{\text{CAS}}$ before $\overline{\text{RAS}}$, t _{RAS} ≤ 1 μs	—	300	—	300	—	300	μA	1, 4, 5
Average Power Supply Current ($\overline{\text{CAS}}$ before $\overline{\text{RAS}}$ Self-Refresh)	I _{CC8}	$\overline{\text{RAS}}$ ≤ 0.2 V, $\overline{\text{CAS}}$ ≤ 0.2 V	—	300	—	300	—	300	μA	1, 5

- Notes :
1. I_{CC} Max. is specified as I_{CC} for output open condition.
 2. The address can be changed once or less while $\overline{\text{RAS}}$ = V_{IL}.
 3. The address can be changed once or less while $\overline{\text{CAS}}$ = V_{IH}.
 4. V_{CC} - 0.2 V ≤ V_{IH} ≤ V_{CC} + 0.5 V, -0.5 V ≤ V_{IL} ≤ 0.2 V.
 5. SL version.

AC Characteristics (1/2)

(V_{CC} = 5 V ±10%, Ta = 0°C to 70°C) Note 1, 2, 3

Parameter	Symbol	MSM5118165 D/DSL-50		MSM5118165 D/DSL-60		MSM5118165 D/DSL-70		Unit	Note
		Min.	Max.	Min.	Max.	Min.	Max.		
		Random Read or Write Cycle Time	t _{RC}	84	—	104	—		
Read Modify Write Cycle Time	t _{RWC}	110	—	135	—	160	—	ns	
Fast Page Mode Cycle Time	t _{HPC}	20	—	25	—	30	—	ns	
Fast Page Mode Read Modify Write Cycle Time	t _{HPRWC}	58	—	68	—	78	—	ns	
Access Time from $\overline{\text{RAS}}$	t _{RAC}	—	50	—	60	—	70	ns	4, 5, 6
Access Time from $\overline{\text{CAS}}$	t _{CAC}	—	13	—	15	—	20	ns	4, 5
Access Time from Column Address	t _{AA}	—	25	—	30	—	35	ns	4, 6
Access Time from $\overline{\text{CAS}}$ Precharge	t _{CPA}	—	30	—	35	—	40	ns	4, 13
Access Time from $\overline{\text{OE}}$	t _{OEa}	—	13	—	15	—	20	ns	4
Output Low Impedance Time from $\overline{\text{CAS}}$	t _{CLZ}	0	—	0	—	0	—	ns	4
Data Output Hold After $\overline{\text{CAS}}$ Low	t _{DOH}	5	—	5	—	5	—	ns	
$\overline{\text{CAS}}$ to Data Output Buffer Turn-off Delay Time	t _{CEZ}	0	13	0	15	0	20	ns	7, 8
$\overline{\text{RAS}}$ to Data Output Buffer Turn-off Delay Time	t _{REZ}	0	13	0	15	0	20	ns	7, 8
$\overline{\text{OE}}$ to Data Output Buffer Turn-off Delay Time	t _{OEZ}	0	13	0	15	0	20	ns	7
$\overline{\text{WE}}$ to Data Output Buffer Turn-off Delay Time	t _{WEZ}	0	13	0	15	0	20	ns	7
Transition Time	t _T	1	50	1	50	1	50	ns	3
Refresh Period	t _{REF}	—	16	—	16	—	16	ms	
Refresh Period (SL version)	t _{REF}	—	128	—	128	—	128	ms	16
$\overline{\text{RAS}}$ Precharge Time	t _{RP}	30	—	40	—	50	—	ns	
$\overline{\text{RAS}}$ Pulse Width	t _{RAS}	50	10,000	60	10,000	70	10,000	ns	
$\overline{\text{RAS}}$ Pulse Width (Fast Page Mode with EDO)	t _{RASP}	50	100,000	60	100,000	70	100,000	ns	
$\overline{\text{RAS}}$ Hold Time	t _{RSH}	7	—	10	—	13	—	ns	
$\overline{\text{RAS}}$ Hold Time referenced to $\overline{\text{OE}}$	t _{ROH}	7	—	10	—	13	—	ns	
$\overline{\text{CAS}}$ Precharge Time (Fast Page Mode with EDO)	t _{CP}	7	—	10	—	10	—	ns	15
$\overline{\text{CAS}}$ Pulse Width	t _{CAS}	7	10,000	10	10,000	13	10,000	ns	
$\overline{\text{CAS}}$ Hold Time	t _{CSH}	35	—	40	—	45	—	ns	
$\overline{\text{CAS}}$ to $\overline{\text{RAS}}$ Precharge Time	t _{CRP}	5	—	5	—	5	—	ns	13
$\overline{\text{RAS}}$ Hold Time from $\overline{\text{CAS}}$ Precharge	t _{RHCP}	30	—	35	—	40	—	ns	13
$\overline{\text{OE}}$ Hold Time from $\overline{\text{CAS}}$ (DQ Disable)	t _{CHO}	5	—	5	—	5	—	ns	
$\overline{\text{RAS}}$ to $\overline{\text{CAS}}$ Delay Time	t _{RCD}	11	37	14	45	14	50	ns	5
$\overline{\text{RAS}}$ to Column Address Delay Time	t _{RAD}	9	25	12	30	12	35	ns	6
Row Address Set-up Time	t _{ASR}	0	—	0	—	0	—	ns	
Row Address Hold Time	t _{RAH}	7	—	10	—	10	—	ns	
Column Address Set-up Time	t _{ASC}	0	—	0	—	0	—	ns	12
Column Address Hold Time	t _{CAH}	7	—	10	—	13	—	ns	12
Column Address to $\overline{\text{RAS}}$ Lead Time	t _{RAL}	25	—	30	—	35	—	ns	

AC Characteristics (2/2)

(V_{CC} = 5 V ±10%, T_a = 0°C to 70°C) Note 1, 2, 3

Parameter	Symbol	MSM5118165 D/DSL-50		MSM5118165 D/DSL-60		MSM5118165 D/DSL-70		Unit	Note
		Min.	Max.	Min.	Max.	Min.	Max.		
Read Command Set-up Time	t _{RCS}	0	—	0	—	0	—	ns	12
Read Command Hold Time	t _{RCH}	0	—	0	—	0	—	ns	9, 12
Read Command Hold Time referenced to $\overline{\text{RAS}}$	t _{RRH}	0	—	0	—	0	—	ns	9
Write Command Set-up Time	t _{WCS}	0	—	0	—	0	—	ns	10, 12
Write Command Hold Time	t _{WCH}	7	—	10	—	13	—	ns	12
Write Command Pulse Width	t _{WP}	7	—	10	—	10	—	ns	
$\overline{\text{WE}}$ Pulse Width (DQ Disable)	t _{WPE}	7	—	10	—	10	—	ns	
$\overline{\text{OE}}$ Command Hold Time	t _{OEH}	7	—	10	—	13	—	ns	
$\overline{\text{OE}}$ Precharge Time	t _{OEP}	7	—	10	—	10	—	ns	
$\overline{\text{OE}}$ Command Hold Time	t _{OCH}	7	—	10	—	10	—	ns	
Write Command to $\overline{\text{RAS}}$ Lead Time	t _{RWL}	7	—	10	—	13	—	ns	
Write Command to $\overline{\text{CAS}}$ Lead Time	t _{CWL}	7	—	10	—	13	—	ns	14
Data-in Set-up Time	t _{DS}	0	—	0	—	0	—	ns	11, 12
Data-in Hold Time	t _{DH}	7	—	10	—	13	—	ns	11, 12
$\overline{\text{OE}}$ to Data-in Delay Time	t _{OED}	13	—	15	—	20	—	ns	
$\overline{\text{CAS}}$ to $\overline{\text{WE}}$ Delay Time	t _{CWD}	30	—	34	—	44	—	ns	10
Column Address to $\overline{\text{WE}}$ Delay Time	t _{AWD}	42	—	49	—	59	—	ns	10
$\overline{\text{RAS}}$ to $\overline{\text{WE}}$ Delay Time	t _{RWD}	67	—	79	—	94	—	ns	10
$\overline{\text{CAS}}$ Precharge $\overline{\text{WE}}$ Delay Time	t _{CPWD}	47	—	54	—	64	—	ns	10
$\overline{\text{CAS}}$ Active Delay Time from $\overline{\text{RAS}}$ Precharge	t _{RPC}	5	—	5	—	5	—	ns	12
$\overline{\text{RAS}}$ to $\overline{\text{CAS}}$ Set-up Time ($\overline{\text{CAS}}$ before $\overline{\text{RAS}}$)	t _{CSR}	5	—	5	—	5	—	ns	12
$\overline{\text{RAS}}$ to $\overline{\text{CAS}}$ Hold Time ($\overline{\text{CAS}}$ before $\overline{\text{RAS}}$)	t _{CHR}	10	—	10	—	10	—	ns	13
$\overline{\text{RAS}}$ Pulse Width ($\overline{\text{CAS}}$ before $\overline{\text{RAS}}$ Self-Refresh)	t _{RASS}	100	—	100	—	100	—	μs	16
$\overline{\text{RAS}}$ Precharge Time ($\overline{\text{CAS}}$ before $\overline{\text{RAS}}$ Self-Refresh)	t _{RPS}	90	—	110	—	130	—	ns	16
$\overline{\text{CAS}}$ Hold Time ($\overline{\text{CAS}}$ before $\overline{\text{RAS}}$ Self-Refresh)	t _{CHS}	-50	—	-50	—	-50	—	ns	16

- Notes:
1. A start-up delay of $200\ \mu\text{s}$ is required after power-up, followed by a minimum of eight initialization cycles ($\overline{\text{RAS}}$ -only refresh or $\overline{\text{CAS}}$ before $\overline{\text{RAS}}$ refresh) before proper device operation is achieved.
 2. The AC characteristics assume $t_T = 2\ \text{ns}$.
 3. V_{IH} (Min.) and V_{IL} (Max.) are reference levels for measuring input timing signals. Transition times (t_T) are measured between V_{IH} and V_{IL} .
 4. This parameter is measured with a load circuit equivalent to 2 TTL loads and 100 pF.
 5. Operation within the t_{RCD} (Max.) limit ensures that t_{RAC} (Max.) can be met. t_{RCD} (Max.) is specified as a reference point only. If t_{RCD} is greater than the specified t_{RCD} (Max.) limit, then the access time is controlled by t_{CAC} .
 6. Operation within the t_{RAD} (Max.) limit ensures that t_{RAC} (Max.) can be met. t_{RAD} (Max.) is specified as a reference point only. If t_{RAD} is greater than the specified t_{RAD} (Max.) limit, then the access time is controlled by t_{AA} .
 7. t_{CEZ} (Max.), t_{REZ} (Max.), t_{WEZ} (Max.) and t_{OEZ} (Max.) define the time at which the output achieves the open circuit condition and are not referenced to output voltage levels.
 8. t_{CEZ} and t_{REZ} must be satisfied for open circuit condition.
 9. t_{RCH} or t_{RRH} must be satisfied for a read cycle.
 10. t_{WCS} , t_{CWD} , t_{RWD} , t_{AWD} and t_{CPWD} are not restrictive operating parameters. They are included in the data sheet as electrical characteristics only. If $t_{\text{WCS}} \geq t_{\text{WCS}}(\text{Min.})$, then the cycle is an early write cycle and the data out will remain open circuit (high impedance) throughout the entire cycle. If $t_{\text{CWD}} \geq t_{\text{CWD}}(\text{Min.})$, $t_{\text{RWD}} \geq t_{\text{RWD}}(\text{Min.})$, $t_{\text{AWD}} \geq t_{\text{AWD}}(\text{Min.})$ and $t_{\text{CPWD}} \geq t_{\text{CPWD}}(\text{Min.})$, then the cycle is a read modify write cycle and data out will contain data read from the selected cell; if neither of the above sets of conditions is satisfied, then the condition of the data out (at access time) is indeterminate.
 11. These parameters are referenced to the $\overline{\text{UCAS}}$ and $\overline{\text{LCAS}}$, leading edges in an early write cycle, and to the $\overline{\text{WE}}$ leading edge in an $\overline{\text{OE}}$ control write cycle, or a read modify write cycle.
 12. These parameters are determined by the falling edge of either $\overline{\text{UCAS}}$ or $\overline{\text{LCAS}}$, whichever is earlier.
 13. These parameters are determined by the rising edge of either $\overline{\text{UCAS}}$ or $\overline{\text{LCAS}}$, whichever is later.
 14. t_{CWL} should be satisfied by both $\overline{\text{UCAS}}$ and $\overline{\text{LCAS}}$.
 15. t_{CP} is determined by the time both $\overline{\text{UCAS}}$ and $\overline{\text{LCAS}}$ are high.
 16. Only SL version.

TIMING WAVEFORM

Read Cycle

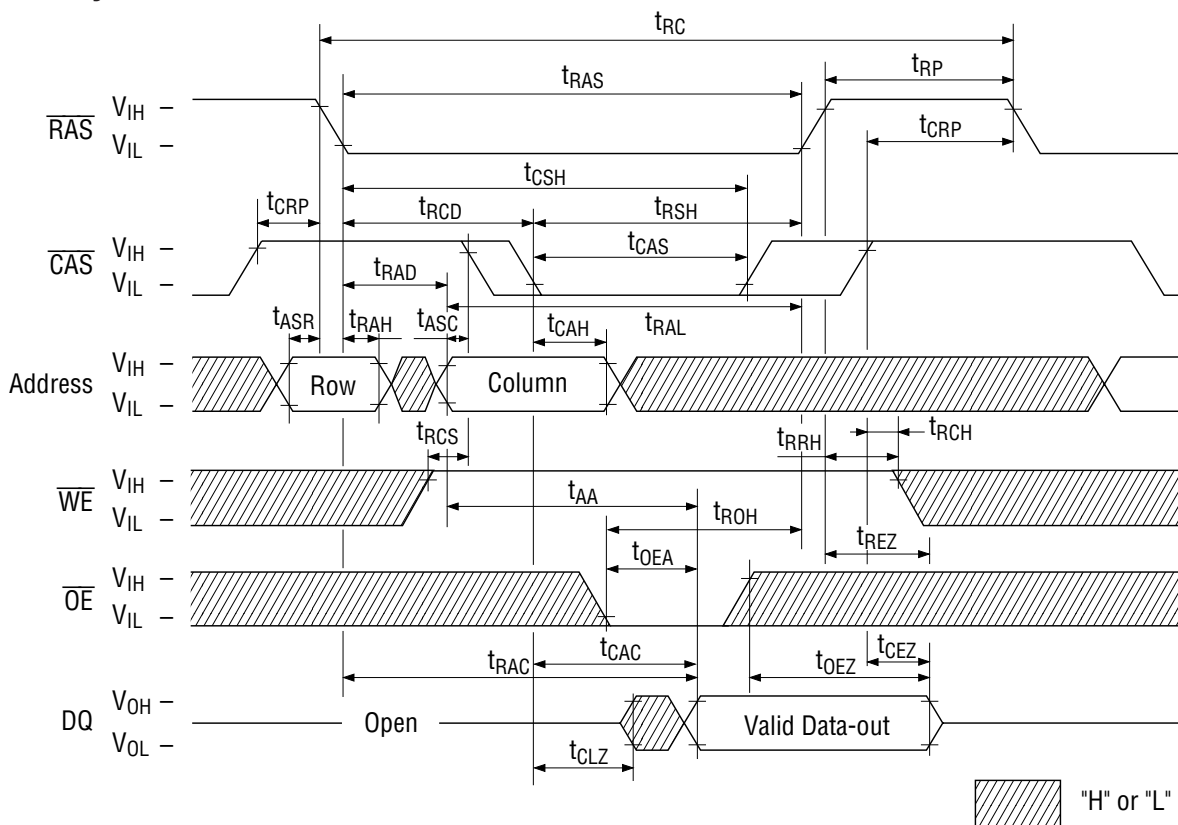

Write Cycle (Early Write)

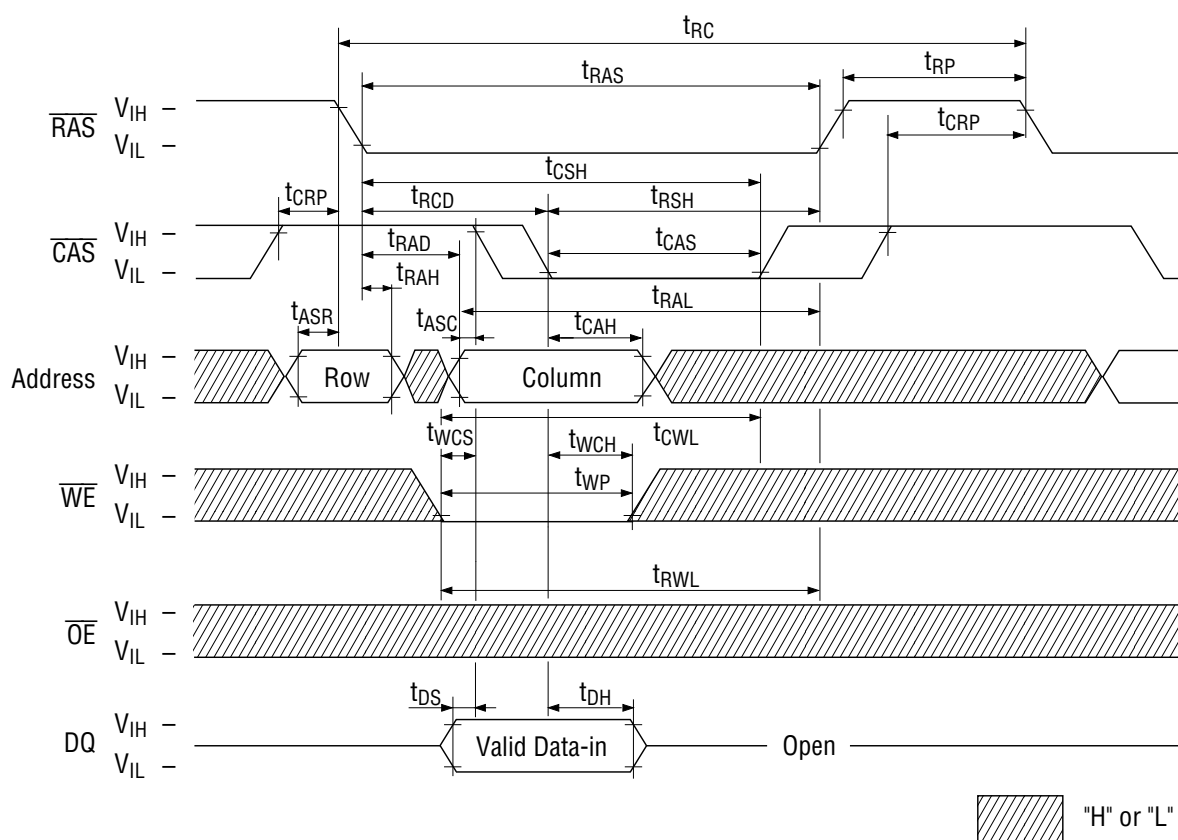

Read Modify Write Cycle

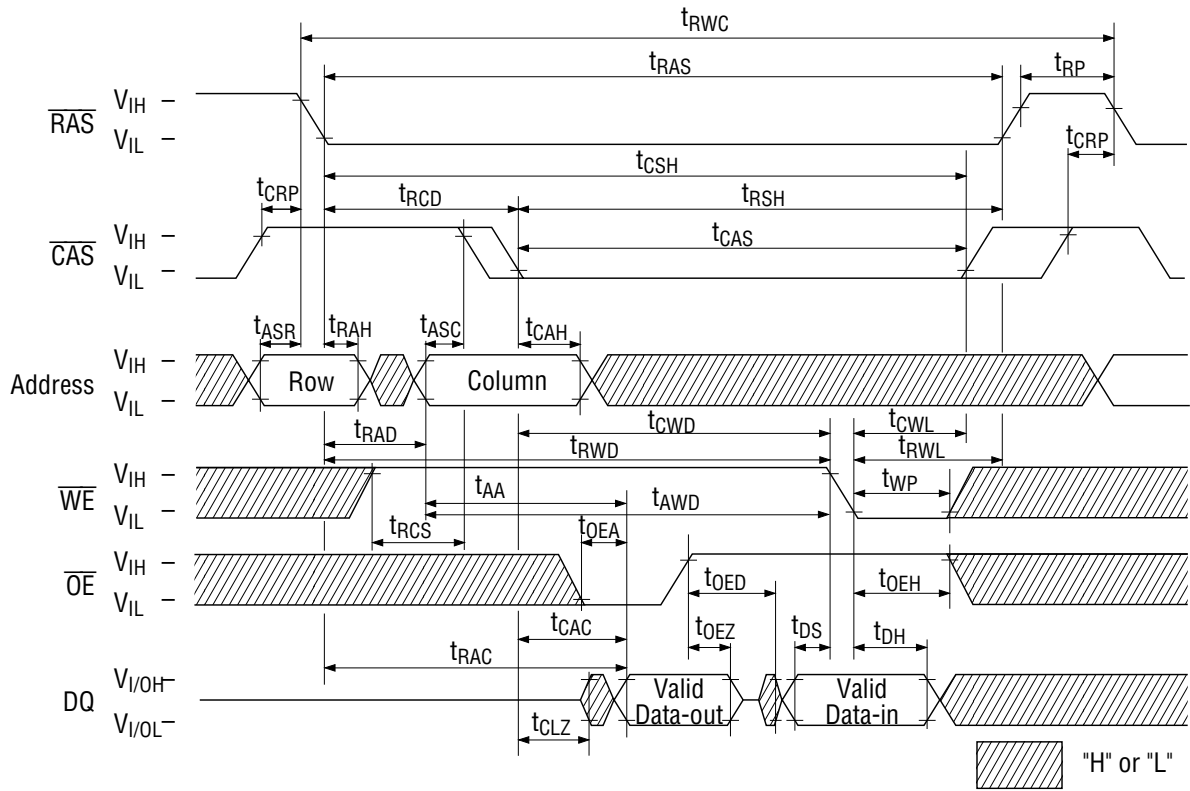

Fast Page Mode Read Cycle (Part-1)

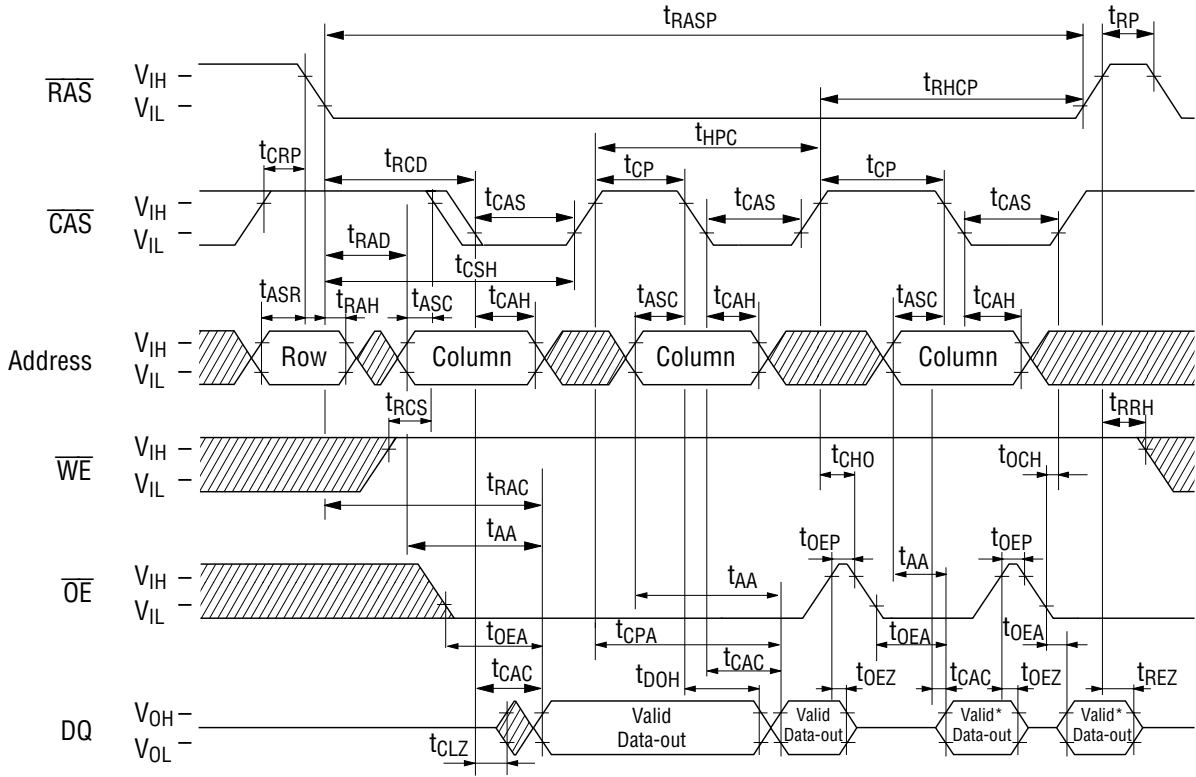

* : Same Data, "H" or "L"

Fast Page Mode Read Cycle (Part-2)

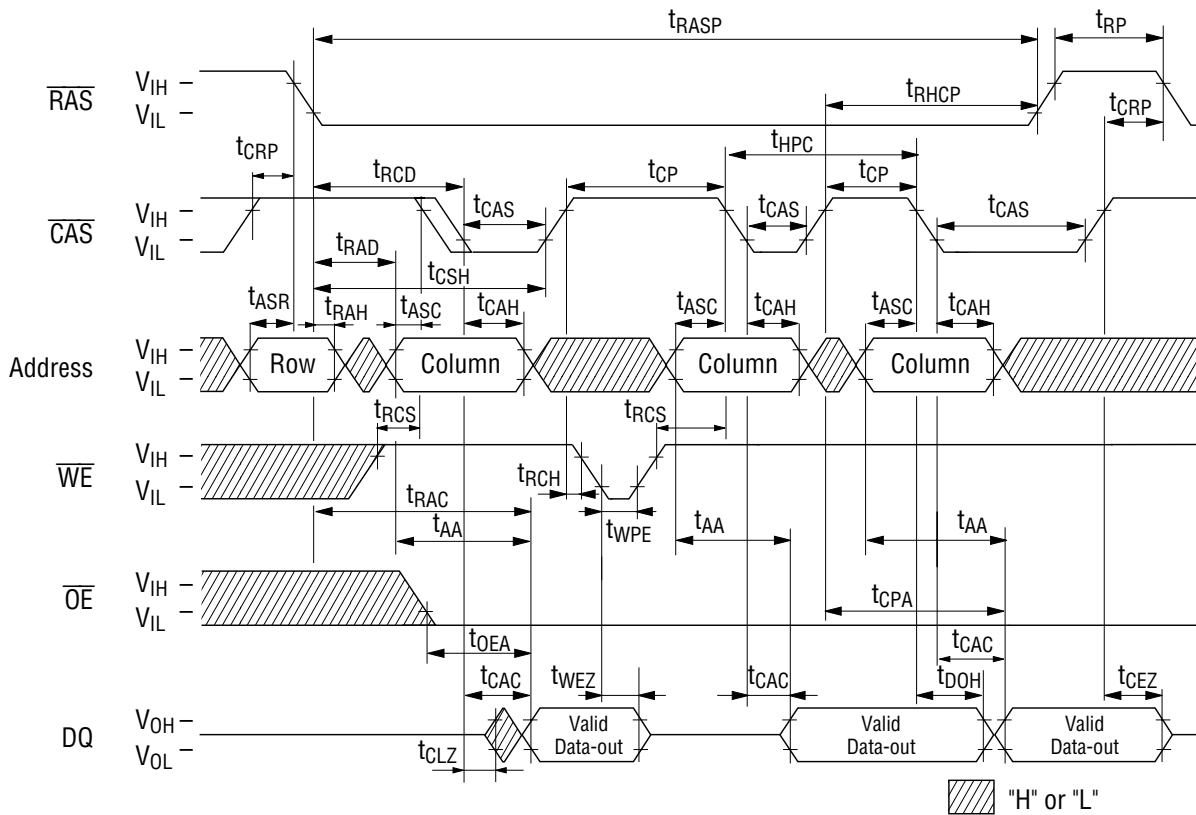

"H" or "L"

Fast Page Mode Write Cycle (Early Write)

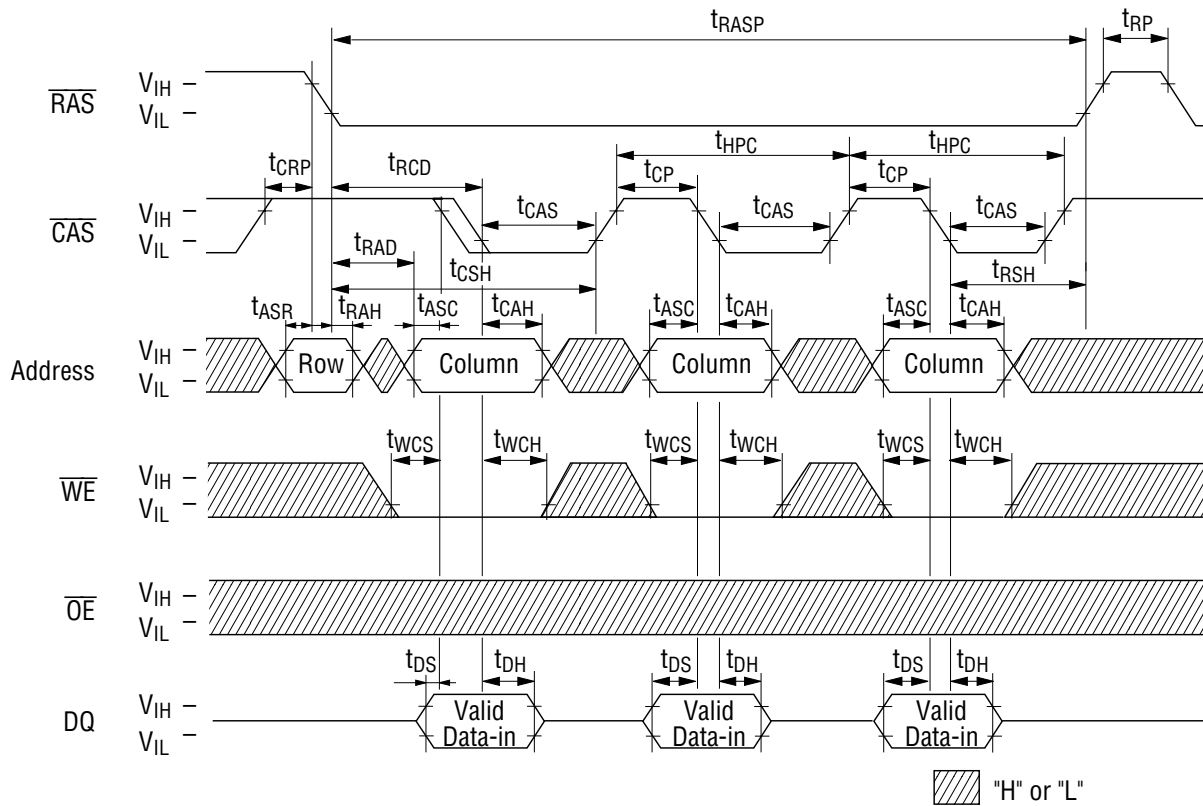

Fast Page Mode Read Modify Write Cycle

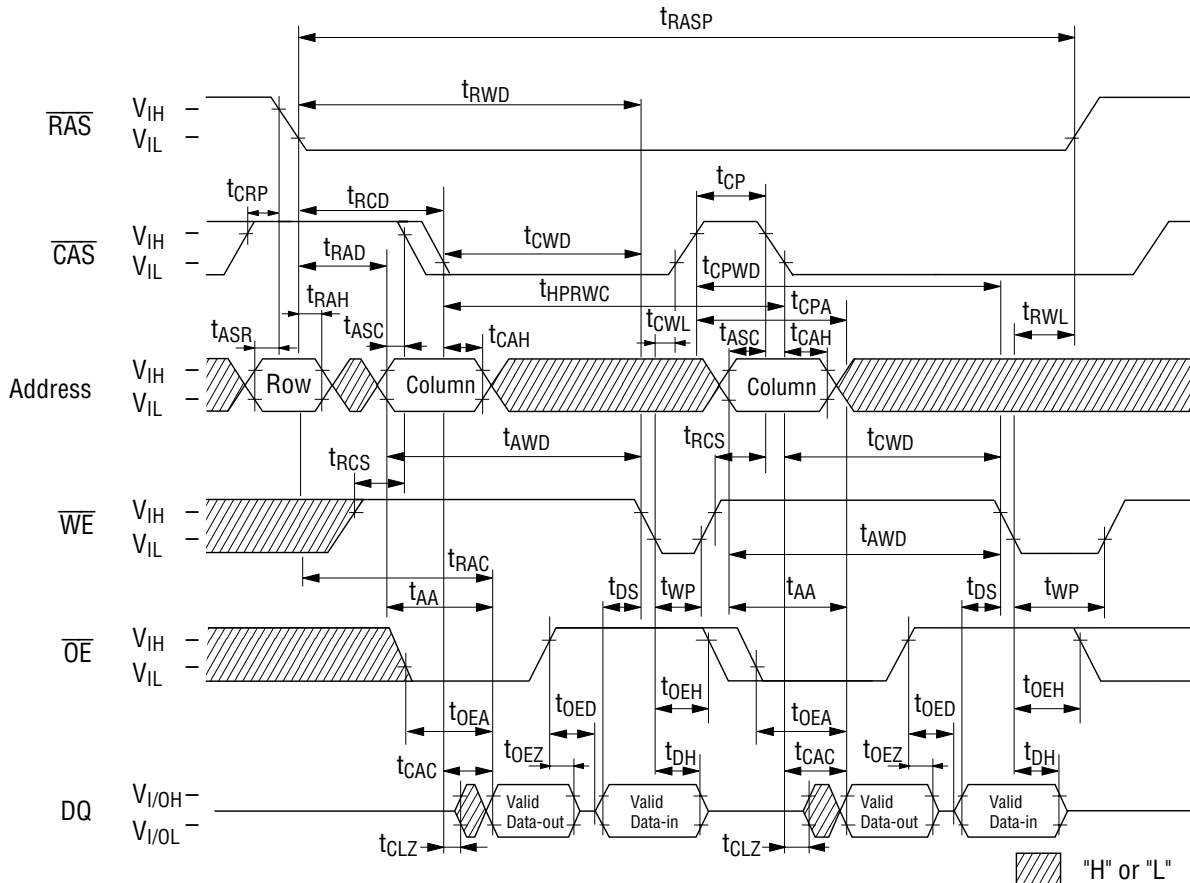

RAS-Only Refresh Cycle

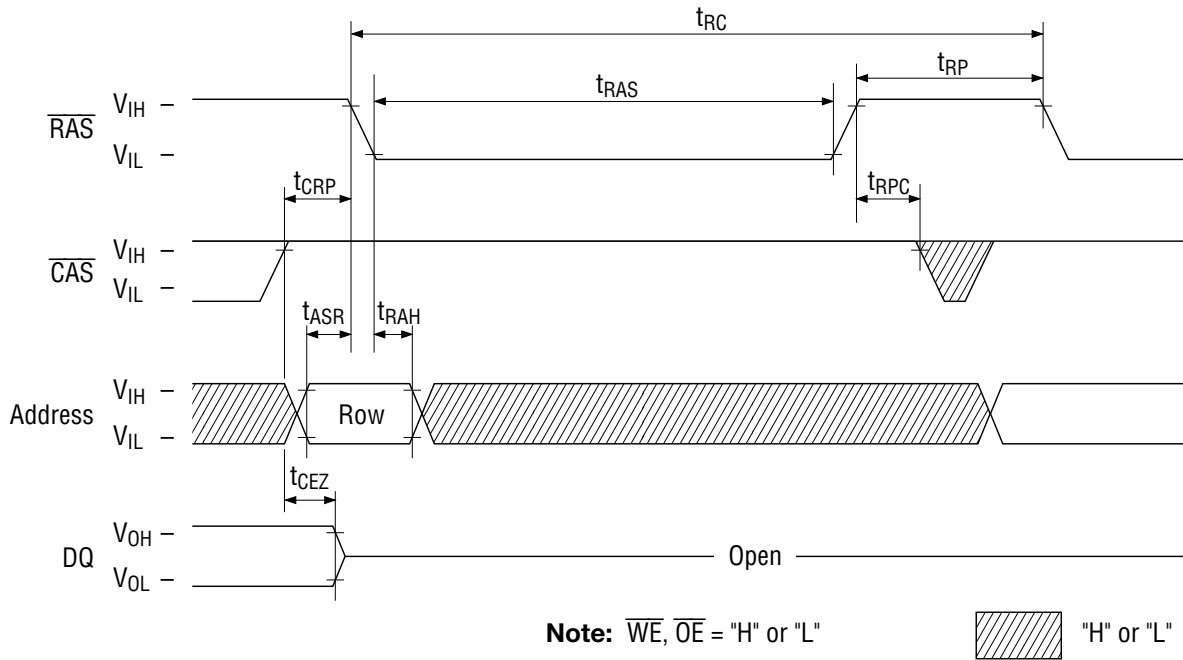

CAS before RAS Refresh Cycle

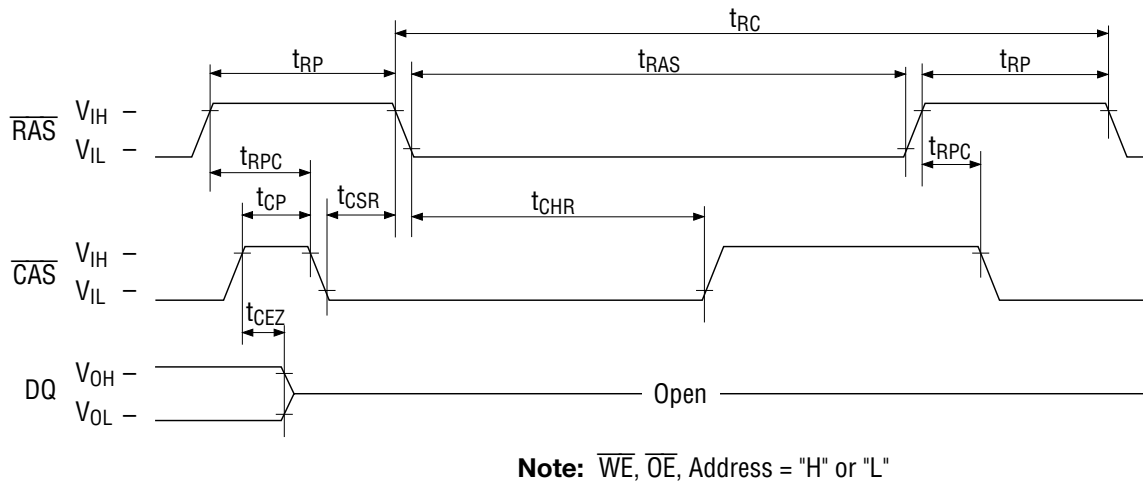

Hidden Refresh Read Cycle

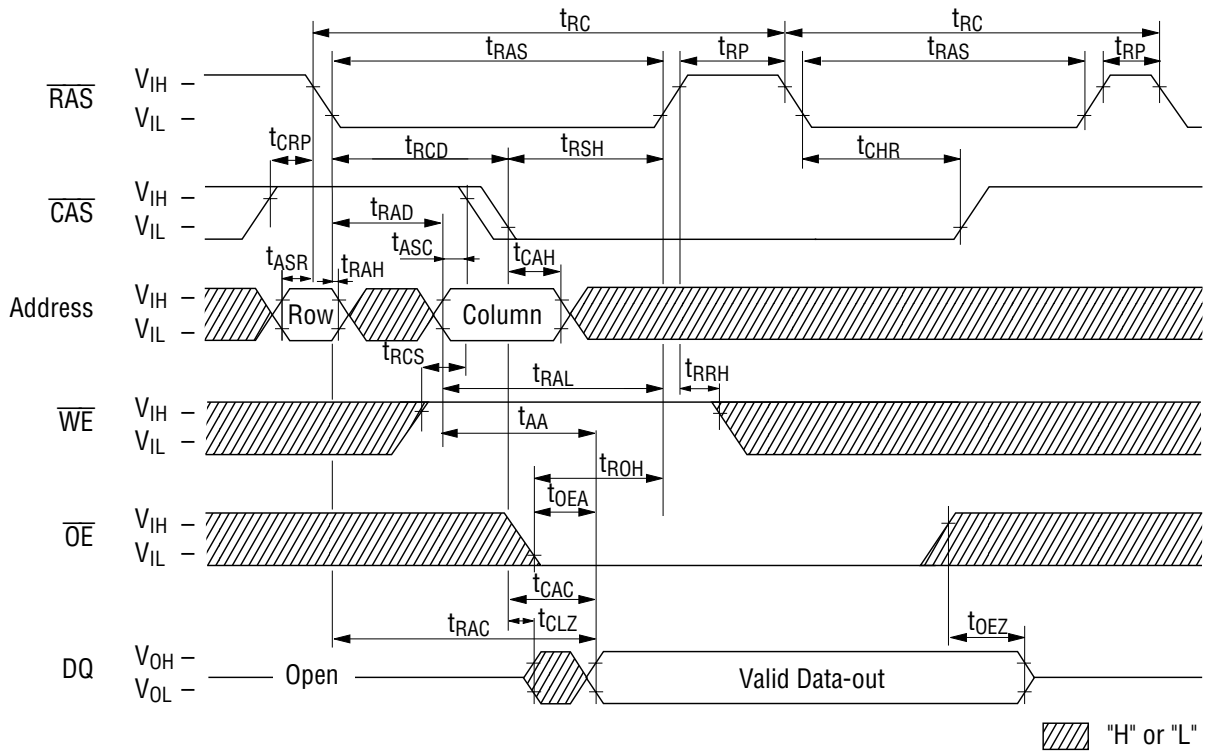

Hidden Refresh Write Cycle

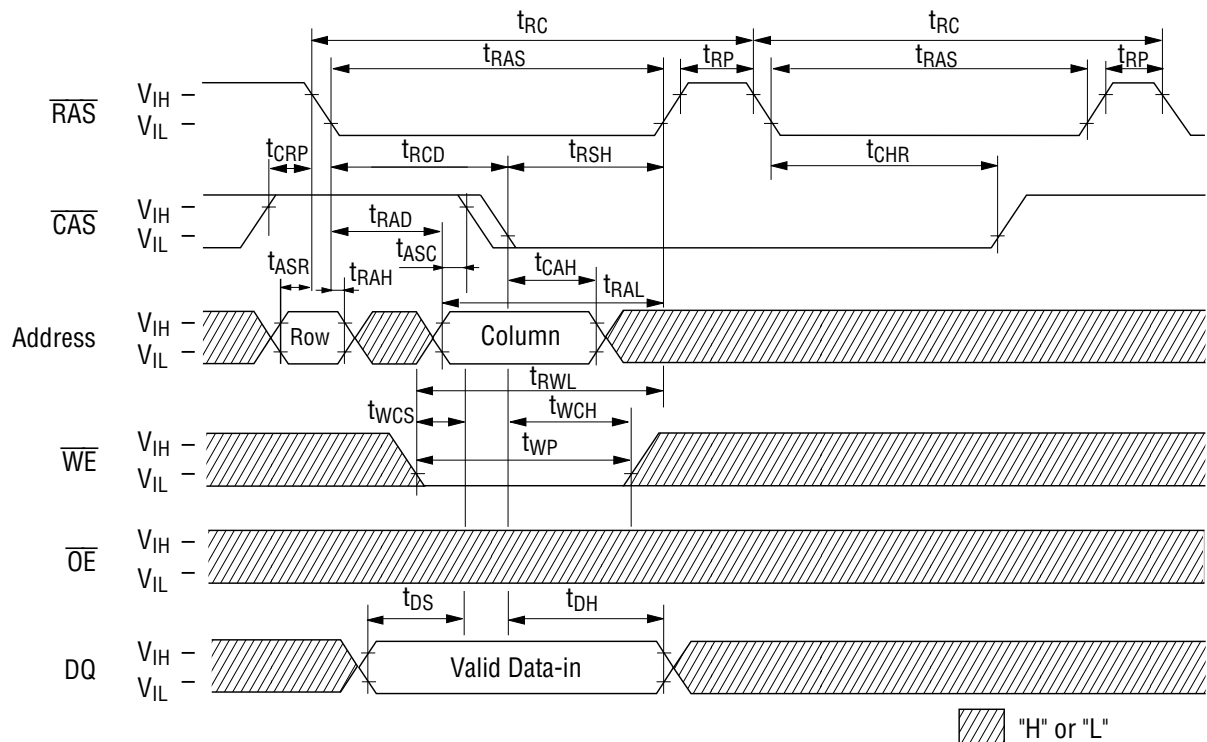

CAS before RAS Self-Refresh Cycle

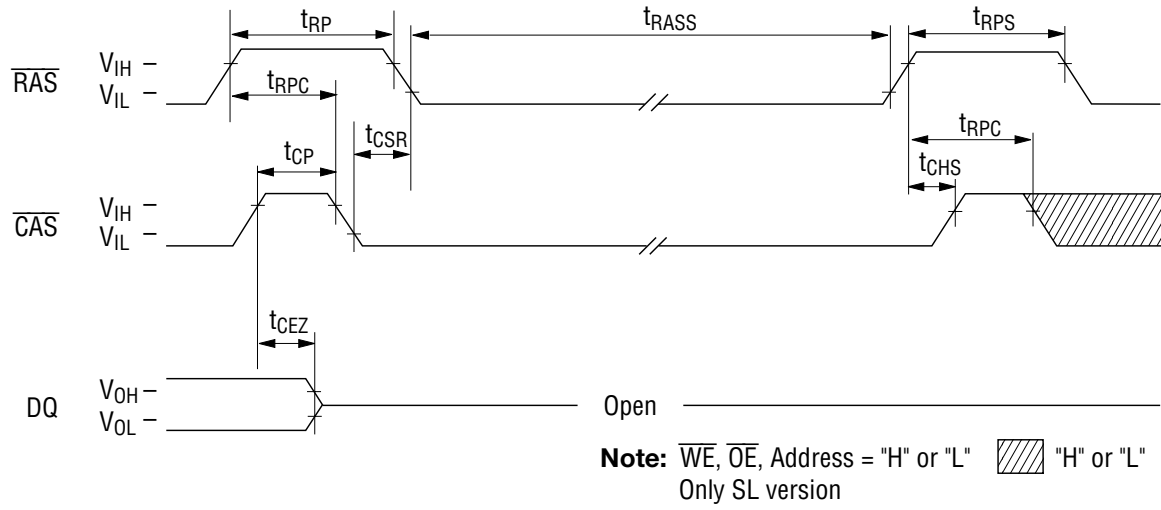

PACKAGE DIMENSIONS

(Unit : mm)

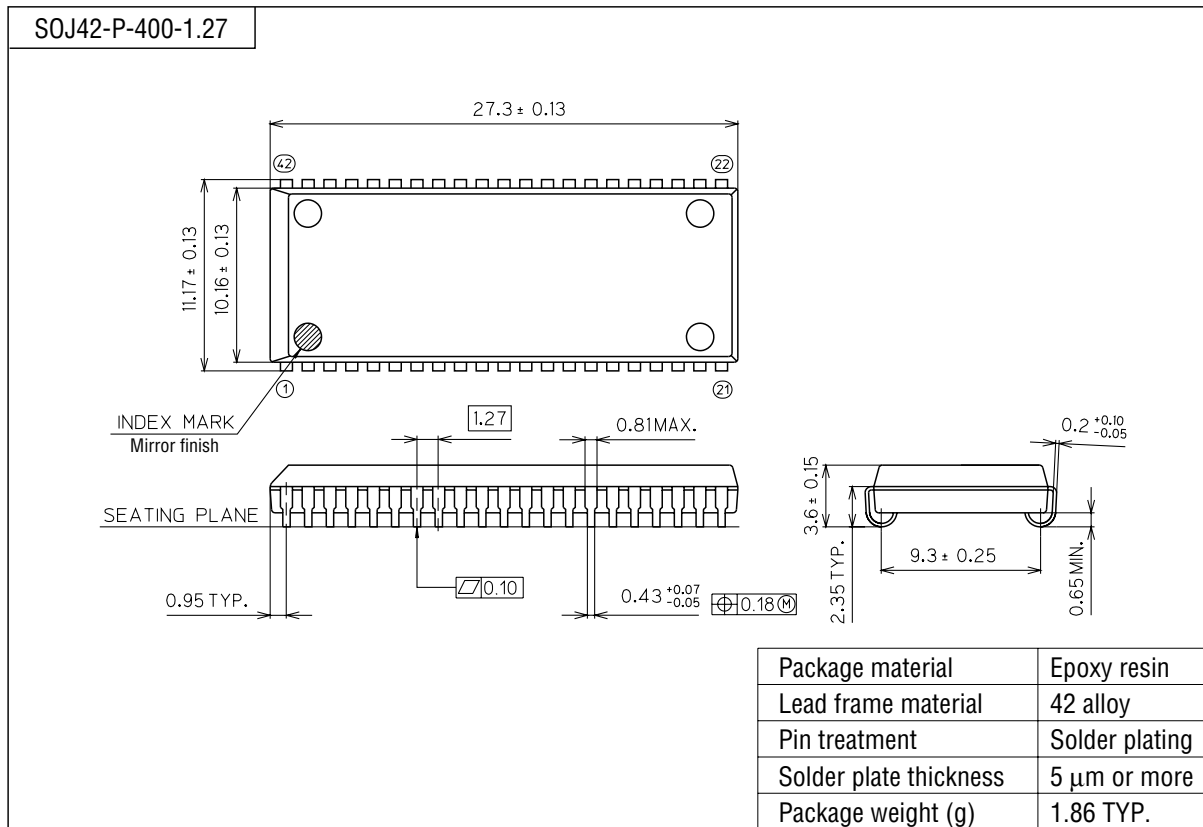

Notes for Mounting the Surface Mount Type Package

The SOP, QFP, TSOP, SOJ, QFJ (PLCC), SHP and BGA are surface mount type packages, which are very susceptible to heat in reflow mounting and humidity absorbed in storage. Therefore, before you perform reflow mounting, contact Oki's responsible sales person for the product name, package name, pin number, package code and desired mounting conditions (reflow method, temperature and times).

(Unit : mm)

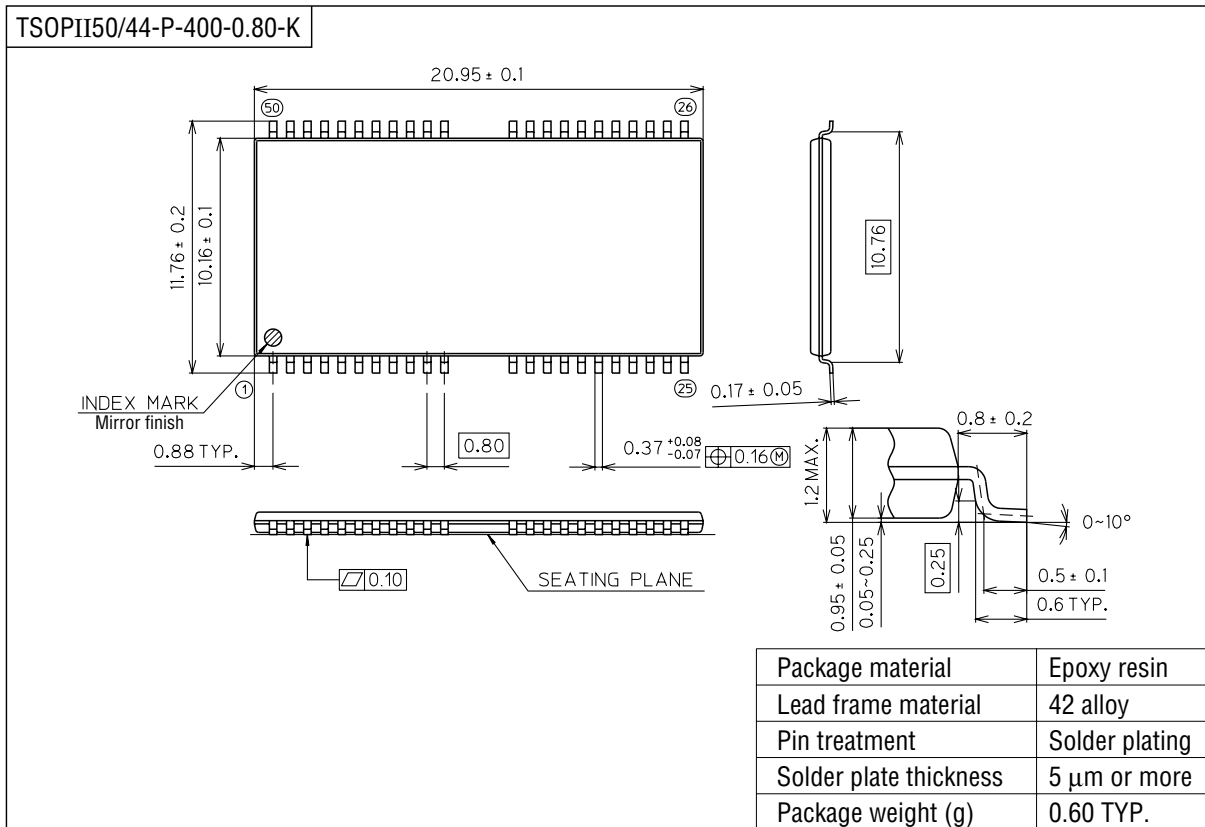

Notes for Mounting the Surface Mount Type Package

The SOP, QFP, TSOP, SOJ, QFJ (PLCC), SHP and BGA are surface mount type packages, which are very susceptible to heat in reflow mounting and humidity absorbed in storage. Therefore, before you perform reflow mounting, contact Oki's responsible sales person for the product name, package name, pin number, package code and desired mounting conditions (reflow method, temperature and times).

NOTICE

1. The information contained herein can change without notice owing to product and/or technical improvements. Before using the product, please make sure that the information being referred to is up-to-date.
2. The outline of action and examples for application circuits described herein have been chosen as an explanation for the standard action and performance of the product. When planning to use the product, please ensure that the external conditions are reflected in the actual circuit, assembly, and program designs.
3. When designing your product, please use our product below the specified maximum ratings and within the specified operating ranges including, but not limited to, operating voltage, power dissipation, and operating temperature.
4. Oki assumes no responsibility or liability whatsoever for any failure or unusual or unexpected operation resulting from misuse, neglect, improper installation, repair, alteration or accident, improper handling, or unusual physical or electrical stress including, but not limited to, exposure to parameters beyond the specified maximum ratings or operation outside the specified operating range.
5. Neither indemnity against nor license of a third party's industrial and intellectual property right, etc. is granted by us in connection with the use of the product and/or the information and drawings contained herein. No responsibility is assumed by us for any infringement of a third party's right which may result from the use thereof.
6. The products listed in this document are intended for use in general electronics equipment for commercial applications (e.g., office automation, communication equipment, measurement equipment, consumer electronics, etc.). These products are not authorized for use in any system or application that requires special or enhanced quality and reliability characteristics nor in any system or application where the failure of such system or application may result in the loss or damage of property, or death or injury to humans. Such applications include, but are not limited to, traffic and automotive equipment, safety devices, aerospace equipment, nuclear power control, medical equipment, and life-support systems.
7. Certain products in this document may need government approval before they can be exported to particular countries. The purchaser assumes the responsibility of determining the legality of export of these products and will take appropriate and necessary steps at their own expense for these.
8. No part of the contents contained herein may be reprinted or reproduced without our prior permission.
9. MS-DOS is a registered trademark of Microsoft Corporation.

Copyright 1998 Oki Electric Industry Co., Ltd.