

OKI electronic components

OPA256C-1

Self-Scanning Line Sensor

GENERAL DESCRIPTION

The OPA256C-1 is a 256-bit, one-dimensional diode array comprised of PN junction photodetector diodes and CCDs (charge coupled devices). By using a two-phase clock pulse, transfer pulse, and reset pulse, the OPA256C-1 can measure incident light.

FEATURES

- CCD for high sensitivity
- CCD transfer efficiency greater than 99.995%
- Photodetector configured of PN junction photodetector diodes for good blue sensitivity and good output uniformity.
- Photodiodes highly integrated with 13 μm pitch for high resolution
- High-speed scanning
- Low-voltage operation
- Internal output amplifier and compensating amplifier

APPLICATIONS

- Industrial control
- Pattern recognition
- Control devices
- Object detection

PIN CONFIGURATION

• Dimensions

(Unit: mm)

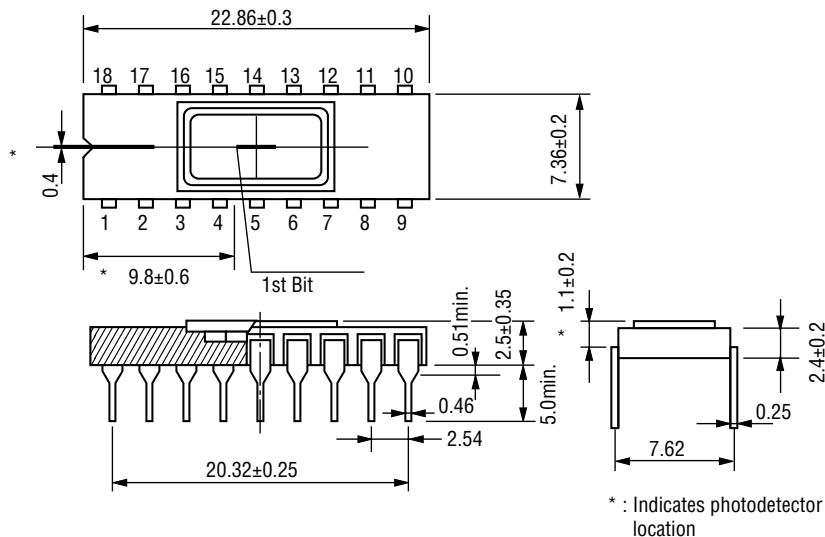

• Pin Connection Block Diagram

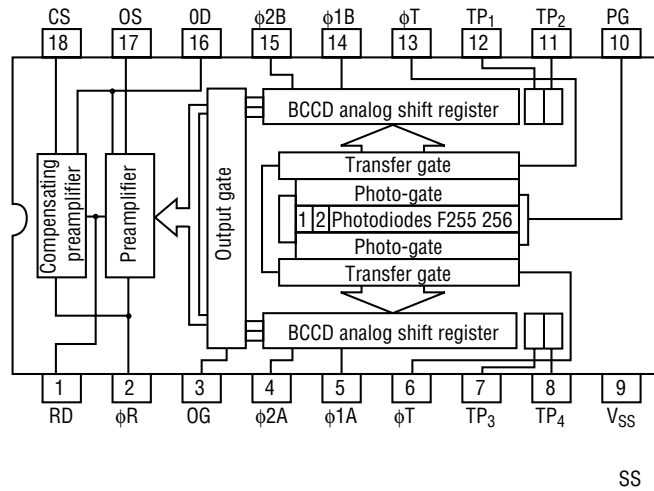

Symbol	Name	Symbol	Name
RD	Reset transistor drain	TP ₁	Test pin (electrical input gate)
φR	Reset transistor gate clock	TP ₂	Test pin (electrical input diode)
OG	Output gate	TP ₃	Test pin (electrical input gate)
φ1A	CCD register clock	TP ₄	Test pin (electrical input diode)
φ1B	CCD register clock	V _{SS}	Substrate bias
φ2A	CCD register clock	PG	Photo-gate
φ2B	CCD register clock	OD	Output transistor drain
φT	Phototransfer gate clock	OS	Output transistor source (video output)
		CS	Compensating transistor source (noise output)

ABSOLUTE MAXIMUM RATINGS

Parameter	Symbol	Test Condition	Min.	Max.	Unit
Storage Temperature	T_{stg}	, —	-40	+125	°C
Operating Temperature	T_{op}	—	-20	+85	°C
Clock Voltage	V_{ϕ}	$T_a=25^{\circ}\text{C}$	-0.3	+18	V
Applied Voltage	V_{DD}		-0.3	+18	V

ELECTRICAL CHARACTERISTICS

(Ambient Temperature $T_a=25^{\circ}\text{C}$)

Parameter		Symbol	Min.	Typ.	Max.	Unit	
Reset Drain Voltage		V_{OD}	11.4	12	12.6	V	
		V_{RD}	11.4	12	12.6	V	
Output Transistor Drain Voltage		V_{OG}	4.75	5	5.25	V	
Output Gate Voltage		V_{PG}	4.75	5	5.25	V	
Photo Gate Voltage		V_{SS}	-1.5	-2.0	-2.5	V	
Electrical Input Diode Voltage (TP _{2,4})		V_{IS}	11.4	12	12.6	V	
Electrical Input Gate Voltage (TP _{1,3})		V_{IG}	-0.1	0	0.2	V	
Clock Pulse Voltage	CCD register	"H"	$V_{\phi_{1,2}^{AB}H}$	7	V_{DD}	V_{DD}	V
		"L"	$V_{\phi_{1,2}^{ABL}}$	0	0.4	0.8	V
	Photo-transfer	"H"	$V_{\phi_{1,2}^{AB}}$	7	V_{DD}	V_{DD}	V
		"L"	$V_{\phi TL}$	0	0.4	0.8	V
	Reset	"H"	$V_{\phi RH}$	7	V_{DD}	V_{DD}	V
		"L"	$V_{\phi RL}$	0	0.4	0.8	V
Video Frequency		f_V	0.1	—	4	MHz	
Clock Input Capacitance	CCD register	$C_{\phi_{1,2}^{AB}}$	—	80	—	pF	
	Photo-transfer	$C_{\phi T}$	—	10	—	pF	
	Reset	$C_{\phi R}$	—	4	—	pF	
Power Dissipation		P_D	—	80	—	mW	
Output Load Resistance		R_L	—	1	—	kΩ	

POTOELECTRIC CHARACTERISTICS

(Ambient Temperature Ta=25°C)

Parameter	Symbol	Min.	Typ.	Max.	Unit	Note
Sensitivity	R _W	—	1500	—	mV/lx • sec	*1
Saturation Output Voltage	V _{sat}	180	250	—	mV	*2
Output Uniformity < *007* > (Overall)	U	—	—	±7	%	*3
Output DC Level	V _{dc}	—	4.0	—	V	—
Dark Output Voltage	V _d	—	—	4	mV	*4

*1 2856K tungsten lamp

*2 V_{RD}, V_{DD}=12 V, V_{SS}=2.0 V, R_L=1 kΩ

*3 When it is 50 percent of the saturation output (2856K tungsten lamp.)
However, this excludes the 1st, 2nd, and 256th bits

*4 Storage time is assumed to be 10 ms.

PIXEL CONFIGURATION

(Ambient Temperature Ta=25°C)

Parameter	Symbol	Central Value	Accuracy	Unit
Arrangement	—	Straight line	—	—
Number of Pixels	—	256	—	—
Pixels Pitch	P	13	±2.0	μm
Photodiode Width	D	8	±2.0	μm
Aperture Width	W	18	±2.5	μm
Sensor Length	L	3328	±3.0	μm

* See output timing for information concerning dummy pixels.

Pixel Configuration Diagram

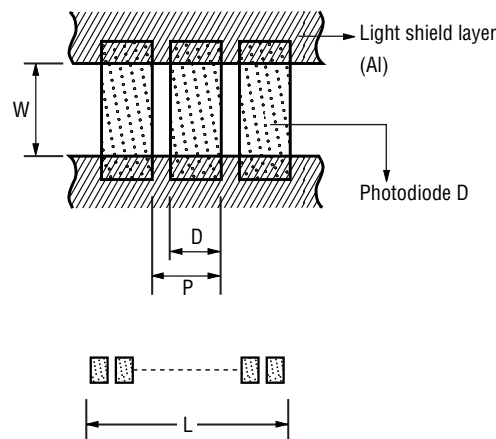

CLOCK INPUT TIMING CHARACTERISTICS

(Ambient Temperature Ta=25°C)

	Parameter	Symbol	Min.	Typ.	Max.	Unit	Note
Register	Rise time	$t_{r\phi}$	—	30	100	ns	*1
	Fall time	$t_{f\phi}$	—	20	100	ns	
	Overlap time	$t_{O\phi 1, 2}$	0	20	100	ns	*2
	Blank time	$t_{B\phi 1, 2}$	—	20	100	ns	*3
Phototransfer	Rise time	$t_{r\phi T}$	—	30	100	ns	*4
	Fall time	$t_{f\phi T}$	—	20	100	ns	
	Transfer time duration	$t_{W\phi R}$	5	10	15	μs	
	Setup time	$t_{S\phi T}$	0	1	10	μs	
	Hold time	$t_{H\phi T}$	0	1	10	μs	
Reset	Rise time	$t_{r\phi R}$	—	30	100	ns	*5
	Fall time	$t_{f\phi R}$	—	20	100	ns	
	Duration	$t_{W\phi R}$	80	—	2000	ns	
	Setup time	$t_{S\phi R}$	170	—	2000	ns	
	Hold time	$t_{H\phi R}$	0	—	2000	ns	

OPA256C-1 Input Timing Diagrams

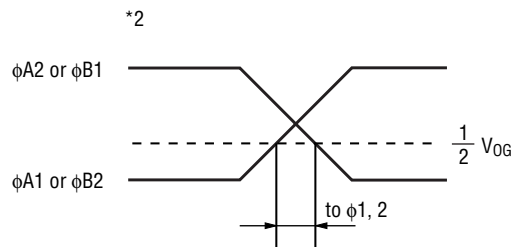
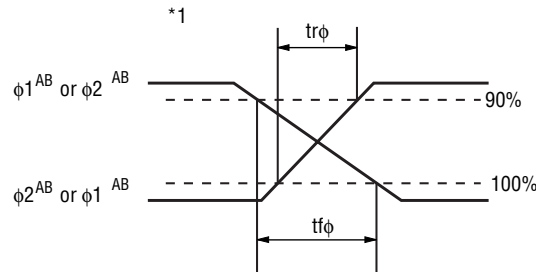

Limited to periods during $\phi A1$ rise and $\phi A2$ fall, and $\phi B2$ rise and $\phi B1$ fall.

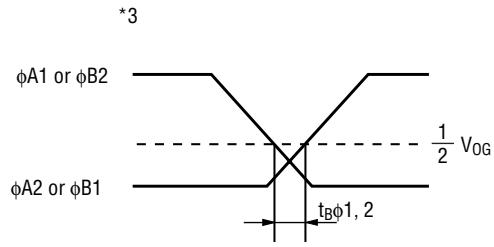

Limited to periods during $\phi A2$ rise and $\phi A1$ fall, and $\phi B1$ rise and $\phi B2$ fall.

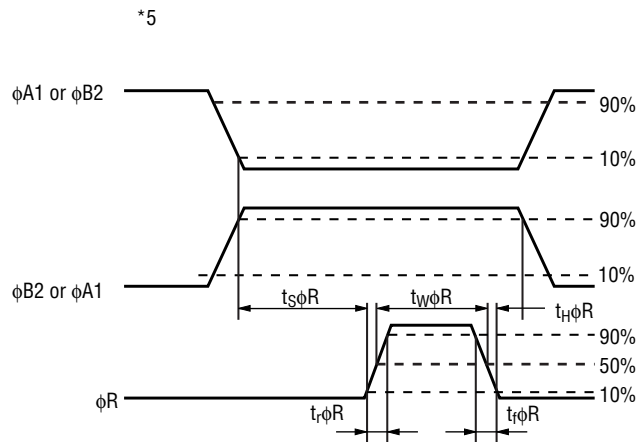
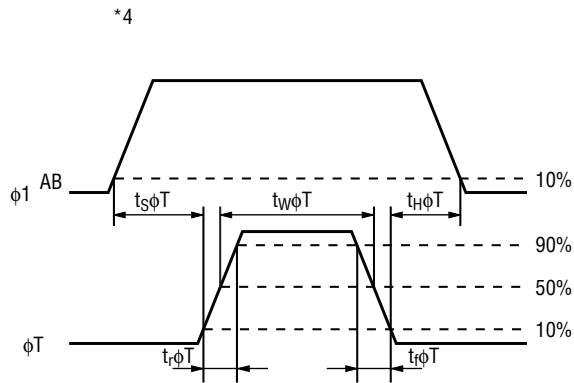

Input Timing Chart

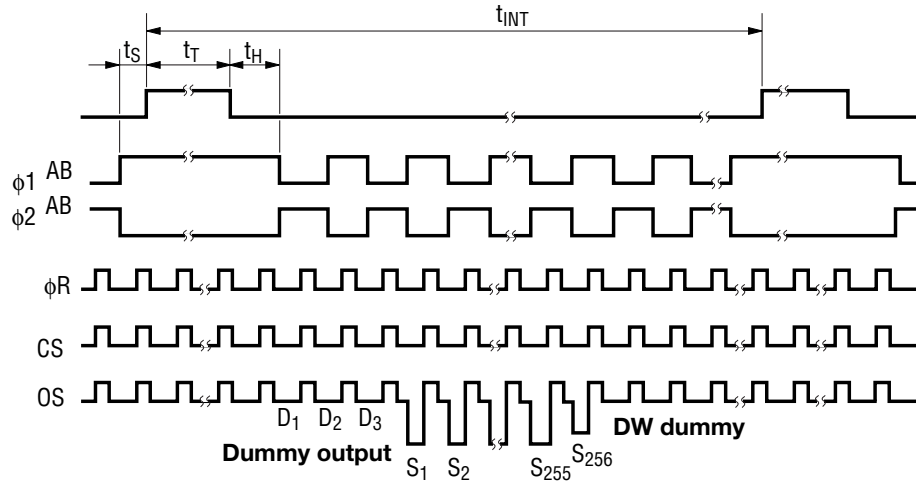

VIDEO OUTPUT TIMING CHARACTERISTICS

(Ambient Temperature $T_a=25^\circ\text{C}$)

Parameter	Symbol	Guaranteed Values			Unit	Note
		Min.	Typ.	Max.		
Video Rise Delay Time	t_{drv}	—	55	—	ns	—
Video Rise Time	t_{rv}	—	55	—	ns	—
Video Fall Delay Time	t_{dfv}	—	15	—	ns	—
Video Fall Time	t_{fv}	—	30	—	ns	—

Conditions	$V_{DD}=V_{RD}=V_{\phi}=12\text{ V}$	$R_L=1\text{ k}\Omega$	$t_{\phi}=30\text{ ns}$
	$V_{DG}=V_{PG}=5\text{ V}$	$C_L=31\text{ pF}$	$t_{r\phi}=35\text{ ns}$
	$V_{SS}=-2\text{ V}$	$T_a=25^\circ\text{C}$	$t_{r\phi R}=15\text{ ns}$

Output Timing Diagrams

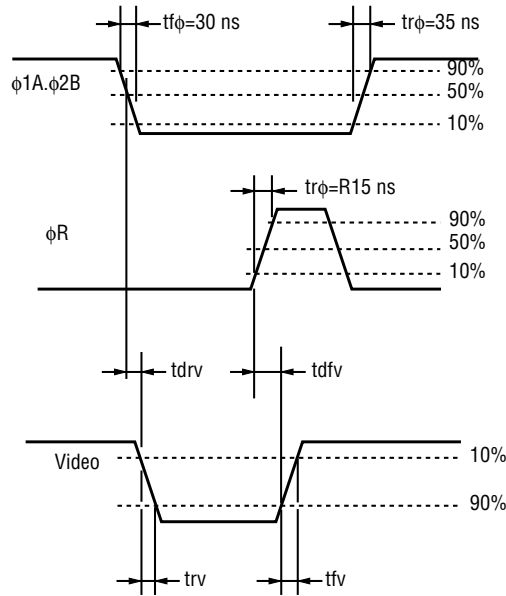

TYPICAL CHARACTERISTICS

- Illuminance vs. Output Characteristics

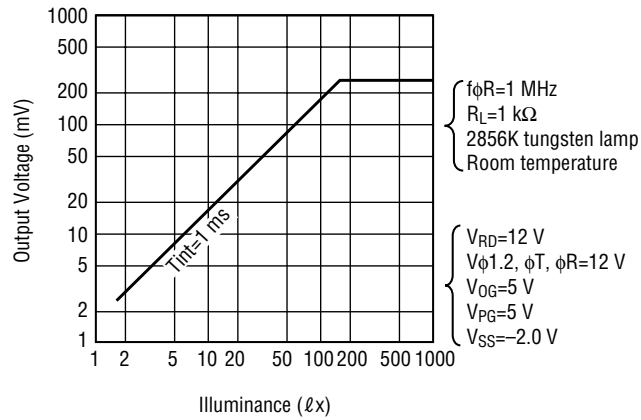

• Spectral Sensitivity Characteristic

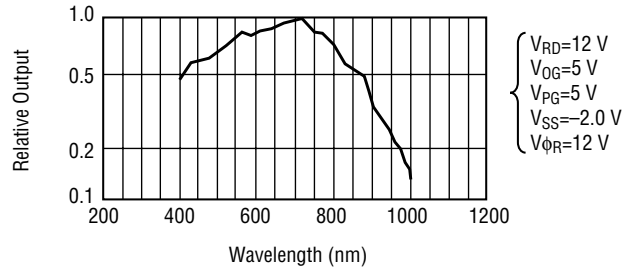

• Dark vs. Temperature Characteristics

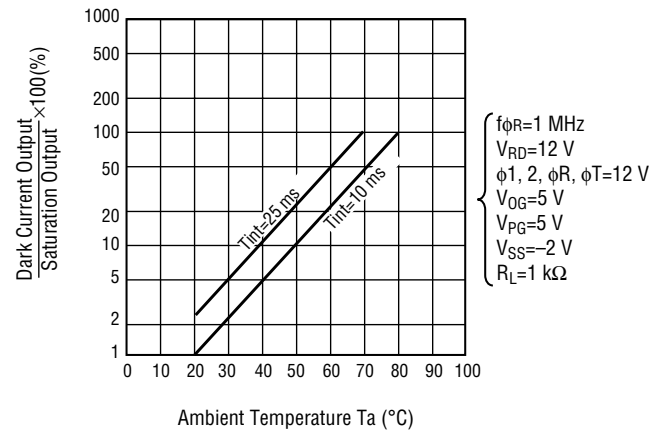

• M.T.F. Characteristics (White Fluorescent Lamp)

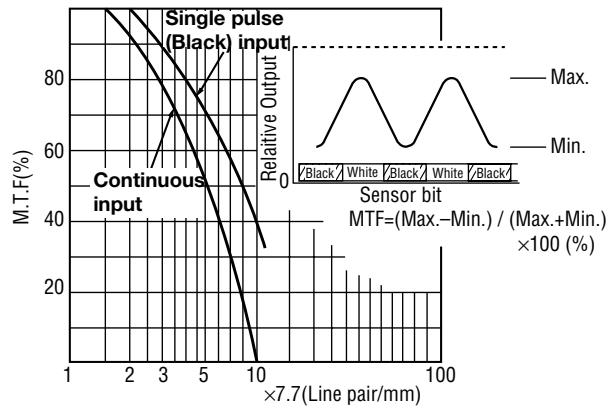

DRIVE CIRCUIT

