



Single-Chip Cable Modem IC with Dual Software Programmable Network-Processing Engines CX24943

Conexant's Next Generation Cable Modem Solution Offers a Higher Level of Integration, Increased Performance, and Lower Power Dissipation

The InfoSurge™ family of products, supporting broadband cable modem applications, presents the industry with yet another example of Conexant's ability to exceed the needs of a growing market segment. The CX24943, Conexant's next generation single-chip cable modem IC, reduces the cost of consumer premise equipment (CPE) by providing a highly integrated, robust and flexible solution.

The CX24943 leads the industry in cost-effectiveness through its high level of integration, advanced process technology, extremely small package and low power consumption. It offers a dual software programmable network-processing engine architecture, allowing for real-time-critical packet management processing for superior performance. The software programmability of this architecture accommodates application specific requirements, worldwide standards, and manufacturers' unique value added features, for maximum flexibility. The CX24943 is software compatible with its predecessor, the CN9414.

A multitude of interfaces are integrated into the chip, including an embedded IEEE 802.3 Media Access Controller (MAC) with a Media Independent Interface (MII), a USB 1.1 communications transceiver, and a host interface. The CX24943 supports internal and external PC cable modems, home networking gateway products, IP (Internet Protocol) telephony products, and digital set-top boxes.



Distinguishing Features

- High level of integration
- Dual software programmable network-processing engines
- 225 MHz system processor
- Less than 500 mW typical power dissipation
- Support for DOCSIS 1.0/1.1, EuroDOCSIS 1.0/1.1, DVB and Proprietary Standards
- Direct IF sampling at 44 and 36 MHz
- Integrated A/Ds and D/As
- Embedded IEEE 802.3 MAC with MII
- 12 Mb USB 1.1 communications transceiver
- Support for home networking standards and VoIP

Single-Chip Cable Modem IC with Dual Software Programmable Network-Processing Engines

CX24943

Highly Integrated

The CX24943 single-chip cable modem IC integrates both downstream and upstream physical layer (PHY) technologies as well as dual software programmable network-processing engines with on-chip memory for cable MAC and application layer processing. The CX24943 provides a cost-effective, single-chip, digital cable communications solution. The IC supports a number of interfaces including: an IEEE 802.3 10/100 Ethernet MAC with MII for access to home networking standards such as HPNA 2.0 and HomePlug; a USB 1.1 transceiver; and a host interface to accommodate IP telephony (VoIP), IEEE 802.11a and IEEE 802.11b wireless networking standards.

The CX24943 was developed using leading-edge process and packaging technologies. This helps drive down the size of the monolithic IC, package and power, while allowing clock rates to increase more than 40% from the previous generation of this product. The CX24943 dissipates less than 500mW of power, setting a new standard for the industry.

The CX24943, through its high level of integration, enables manufacturers to achieve cost targets unparalleled in the industry. The additional components required to develop a complete cable modem are minimal as shown in the CX24943-based Cable Modem block diagram.

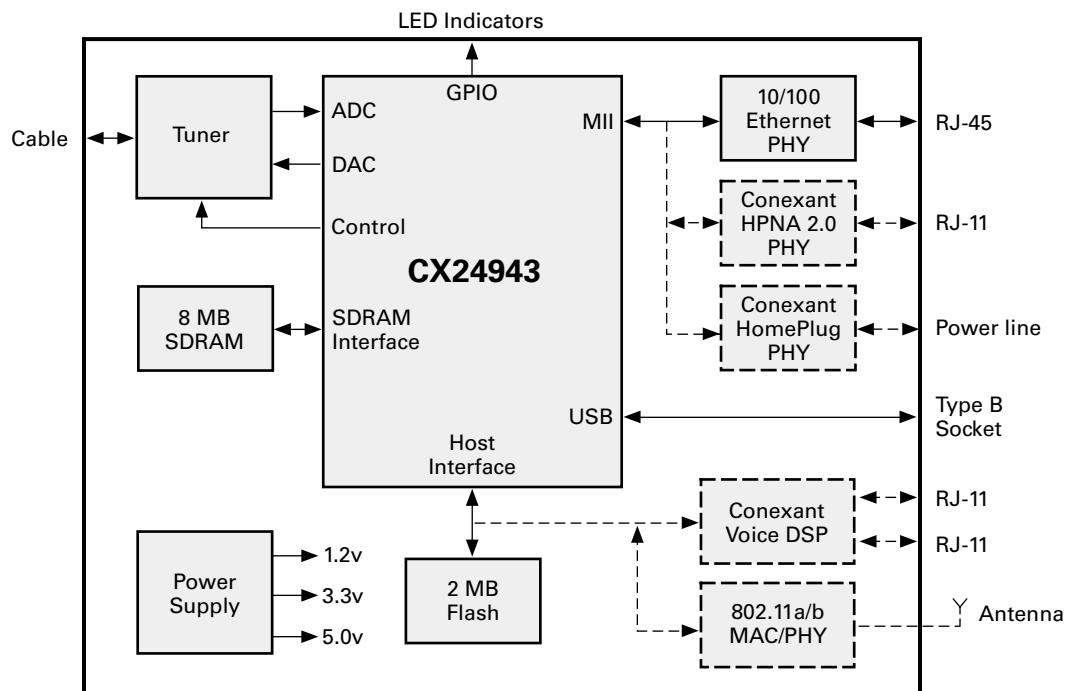

CX24943-based Cable Modem block diagram



Increased Performance

The CX24943 utilizes the proven architecture of its predecessor, the CN9414, and boosts performance by increasing the system processor speed to 225 MHz. The CX24943 Single-Chip Cable Modem IC block diagram shows the major functional blocks of the monolithic IC.

Conexant's sixth-generation physical-layer downstream receiver includes a 10-bit A/D that accepts a direct IF signal (at 44 or 36 MHz) and a 16/256 QAM demodulator with Annex A and B forward error correction. The CX24943 also contains an 11-bit D/A converter, which can accommodate 65 MHz of upstream bandwidth for EuroDOCSIS and DVB applications, and a QPSK/16 QAM burst upstream modulator. Conexant's proven PHY technology exceeds all DOCSIS™/EuroDOCSIS™ 1.0/1.1 requirements for low BERs in noise-filled environments.

The CX24943 is the fastest solution in the industry with integrated dual software programmable network-processing engines on board. Its unique packet management, unified memory architecture, and advanced system buses, maximize performance by allowing segmentation of real-time-critical DOCSIS/EuroDOCSIS 1.0/1.1 functions from non real-time-critical application processes. The CX24943's processor performance and unique architecture enables DOCSIS/EuroDOCSIS 1.1 and other software applications, including: firewall for added security; routing for home networking; or VoIP for low-cost IP telephony.

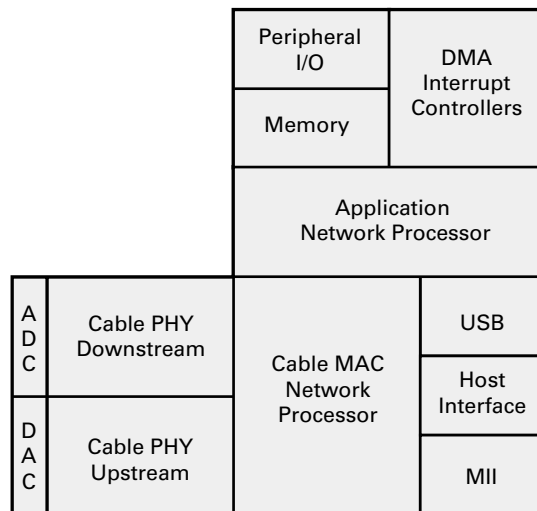

CX24943 Single-Chip Cable Modem IC block diagram

High Flexibility

Cable modem manufacturers have to devote a significant amount of resources to bring new certifiable solutions to market. The unique architecture of the CX24943 provides a number of advantages for cable modem manufacturers and cable operators alike. The software programmability of the dual network-processing engine allows manufacturers to customize the CX24943 for application specific requirements, both at the cable MAC and software applications layer. This feature allows one base platform to support numerous products, including IP telephony, home networking and set-top box as shown in the CX24943-based Cable Modem block diagram. In addition, the architectural similarities between the CX24943 and its predecessor, the CN9414, allows for maximum reuse of certified code.

The CX24943 provides the option to adapt to a multitude of standards by downloading different software into the

embedded dual network-processing engine, including DOCSIS/EuroDOCSIS 1.0/1.1, DVB and proprietary standards. Finally, cable operators can download feature enhancements to field-deployed solutions, minimizing truck rolls and equipment obsolescence.

Complete Solution

To reduce the resources and development time required to bring CX24943-based cable modem solutions to market, Conexant provides complete certifiable DOCSIS/EuroDOCSIS 1.0/1.1 Cable Modem Reference Designs. The Cable Modem Reference Designs include software that is not only compliant to DOCSIS/EuroDOCSIS 1.0/1.1 and meet the network requirements of @Home, but also include the USB drivers that meet Microsoft's Windows Hardware Quality Lab (WHQL) requirements. Additional software enhancements that are above and beyond standards-based requirements are also included in this complete software offering.

Product Features

Cable PHY Downstream

- 10-bit A/D
- Direct IF sampling at 44 and 36 MHz
- 16/256 QAM Demodulator
- Programmable equalization
- Annex A and B FEC

Cable PHY Upstream

- 11-bit D/A
- QPSK/16 QAM burst modulator
- Programmable pre-equalization

DMA Interrupt Controller

- 16 asynchronous channels
- Memory to memory moves: aligned/unaligned
- Source/destination mode for simple data transfer
- Circular/linked buffer support for inbound/outbound data

Peripheral I/O

- 32 GPIO
- JTAG boundary scan
- UART

Cable MAC Network Processor

- **Software Programmable**
 - DOCSIS 1.0/1.1 compliant
 - EuroDOCSIS 1.0/1.1 compliant
 - DVB compliant
 - Fixed wireless compliant
 - Proprietary standards

Application Network Processor

- ARM940T microcontroller
- Up to 225 MHz operation
- 4KB Instruction and 4KB Data Cache
- Embedded ICE and debug extensions
- PID, SID, DA/SA, MAC, IP and LLC Filtering
- Four 56-bit DES/CRC engines
- HCS 16- and 32-bit CRC single-cycle engines

MII

- IEEE 802.3 MAC layer
- **Networking technologies**
 - 10/100 Ethernet
 - Conexant HPNA 2.0
 - Conexant HomePlug 1.0

Host Interface

- **Master mode**
 - 16-bit data
 - 8-chip selects
- **Supports Flash, IP telephony, IEEE 802.11a or IEEE 802.11b**
- **16/32-bit Slave mode (external host and test)**

USB 1.1

- Integrated 12 Mb transceiver
- Communications Peripheral device

Memory

- Internal 8 K x 32 SRAM
- External SDRAM Interface
 - 16-bit interface
 - Supports both 4 MB and 8 MB technologies

Phase-Locked Loops (4)

- TDM clock and frame sync generator
- Transmit clock generator
- Supplied 25MHz Ethernet reference clock
- Internal USB clock

Miscellaneous Functions

- Watchdog Timer
- Four additional timers
- Interrupt controller

Package and Power

- 228 PBGA
- All I/O at 3.3V
- Power supply: 3.3V and 1.2V
- <500 mW (typical)

Reference Designs

- DOCSIS 1.0/1.1
- EuroDOCSIS 1.0/1.1
- PCI

Product Applications

(DOCSIS/EuroDOCSIS 1.0/1.1, DVB, Proprietary)

- Cable Modems with Ethernet
- Cable Modems with USB
- Cable Modems with IP Telephony
- PCI Cable Modem Card Internal (CMCI)
- Cable Modem with Home Networking
- PCMCIA Cable Modem
- Digital Set-Top Box with Cable Modem

www.conexant.com

General Information:

U.S. and Canada: (800) 854-8099

International: (949) 483-6996

Headquarters – Newport Beach

4311 Jamboree Rd, P.O. Box C

Newport Beach, CA 92660-3095

Order# 101645B

01-0430

© 2001, Conexant Systems, Inc. All Rights Reserved.

Conexant and the Conexant logo are trademarks of Conexant Systems, Inc. Other trademarks are owned by their respective owners. Although Conexant strives for accuracy in all its publications, this material may contain errors or omissions and is subject to change without notice. **THIS MATERIAL IS PROVIDED AS IS AND WITHOUT ANY EXPRESS OR IMPLIED WARRANTIES, INCLUDING MERCHANTABILITY, FITNESS FOR A PARTICULAR PURPOSE AND NON-INFRINGEMENT.** Conexant shall not be liable for any special, indirect, incidental or consequential damages as a result of its use.



CONEXANT™

What's next in communications technologies