

D3SB10 - D3SB80

PRV : 100 - 800 Volts

Io : 4.0 Amperes

FEATURES :

- * High current capability
- * High surge current capability
- * High reliability
- * Low reverse current
- * Low forward voltage drop
- * Ideal for printed circuit board
- * Very good heat dissipation
- * **Pb / RoHS Free**

MECHANICAL DATA :

- * Case : Reliable low cost construction utilizing molded plastic technique
- * Epoxy : UL94V-O rate flame retardant
- * Terminals : Plated lead solderable per MIL-STD-202, Method 208 guaranteed
- * Polarity : Polarity symbols marked on case
- * Mounting position : Any
- * Weight : 4.28 grams

SILICON BRIDGE RECTIFIERS

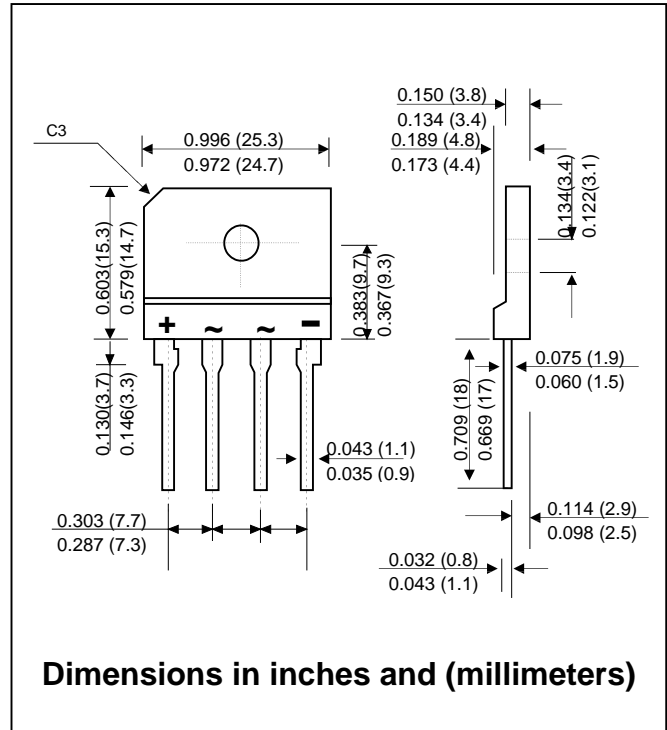

MAXIMUM RATINGS AND ELECTRICAL CHARACTERISTICS

Rating at 25 °C ambient temperature unless otherwise specified.

Single phase, half wave, 60 Hz, resistive or inductive load.

For capacitive load, derate current by 20%.

RATING	SYMBOL	D3S B10	D3S B20	D3S B40	D3S B60	D3S B80	UNIT
Maximum Recurrent Peak Reverse Voltage	V_{RRM}	100	200	400	600	800	V
Maximum Reverse Voltage	V_R	100	200	400	600	800	V
Maximum Average Forward Current $T_c = 25^\circ\text{C}$	$I_{F(AV)}$	4.0					A
Maximum Peak Forward Surge Current	I_{FSM}	120					A
Maximum Forward Voltage per Diode at $I_F = 2.0\text{ A}$	V_F	1.05					V
Maximum Reverse Current at Reverse Voltage	I_R	10					μA
Maximum Reverse Current at Reverse Voltage $T_a = 100^\circ\text{C}$	$I_{R(H)}$	100					μA
Operating Junction Temperature Range	T_J	- 40 to + 150					$^\circ\text{C}$
Storage Temperature Range	T_{STG}	- 40 to + 150					$^\circ\text{C}$

RATING AND CHARACTERISTIC CURVES (D3SB10 - D3SB80)

FIG.1 - DERATING CURVE FOR OUTPUT RECTIFIED CURRENT

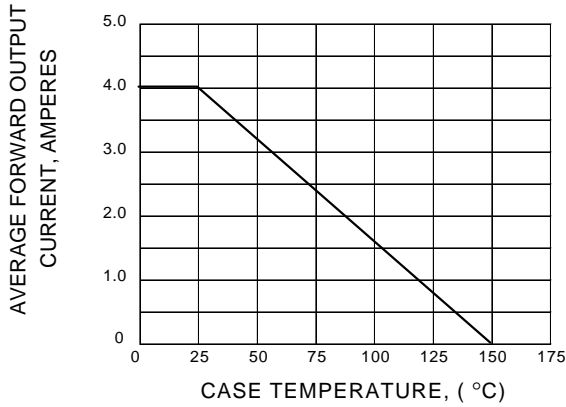

FIG.2 - MAXIMUM NON-REPETITIVE PEAK FORWARD SURGE CURRENT

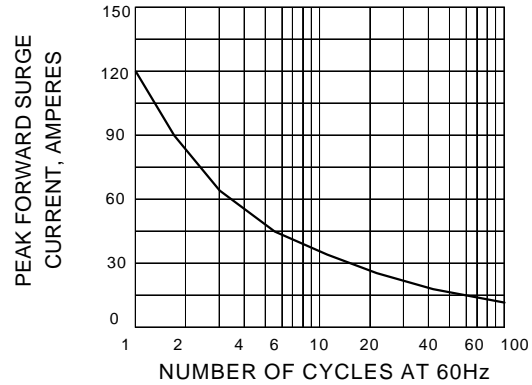

FIG.3 - TYPICAL FORWARD CHARACTERISTICS

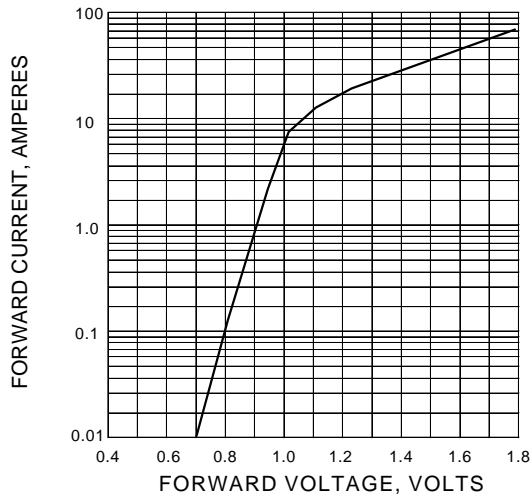

FIG.4 - TYPICAL REVERSE CHARACTERISTICS

