

To all our customers

Regarding the change of names mentioned in the document, such as Hitachi Electric and Hitachi XX, to Renesas Technology Corp.

The semiconductor operations of Mitsubishi Electric and Hitachi were transferred to Renesas Technology Corporation on April 1st 2003. These operations include microcomputer, logic, analog and discrete devices, and memory chips other than DRAMs (flash memory, SRAMs etc.) Accordingly, although Hitachi, Hitachi, Ltd., Hitachi Semiconductors, and other Hitachi brand names are mentioned in the document, these names have in fact all been changed to Renesas Technology Corp. Thank you for your understanding. Except for our corporate trademark, logo and corporate statement, no changes whatsoever have been made to the contents of the document, and these changes do not constitute any alteration to the contents of the document itself.

Renesas Technology Home Page: <http://www.renesas.com>

Renesas Technology Corp.
Customer Support Dept.
April 1, 2003

Cautions

Keep safety first in your circuit designs!

1. Renesas Technology Corporation puts the maximum effort into making semiconductor products better and more reliable, but there is always the possibility that trouble may occur with them. Trouble with semiconductors may lead to personal injury, fire or property damage.
Remember to give due consideration to safety when making your circuit designs, with appropriate measures such as (i) placement of substitutive, auxiliary circuits, (ii) use of nonflammable material or (iii) prevention against any malfunction or mishap.

Notes regarding these materials

1. These materials are intended as a reference to assist our customers in the selection of the Renesas Technology Corporation product best suited to the customer's application; they do not convey any license under any intellectual property rights, or any other rights, belonging to Renesas Technology Corporation or a third party.
2. Renesas Technology Corporation assumes no responsibility for any damage, or infringement of any third-party's rights, originating in the use of any product data, diagrams, charts, programs, algorithms, or circuit application examples contained in these materials.
3. All information contained in these materials, including product data, diagrams, charts, programs and algorithms represents information on products at the time of publication of these materials, and are subject to change by Renesas Technology Corporation without notice due to product improvements or other reasons. It is therefore recommended that customers contact Renesas Technology Corporation or an authorized Renesas Technology Corporation product distributor for the latest product information before purchasing a product listed herein.
The information described here may contain technical inaccuracies or typographical errors. Renesas Technology Corporation assumes no responsibility for any damage, liability, or other loss rising from these inaccuracies or errors.
Please also pay attention to information published by Renesas Technology Corporation by various means, including the Renesas Technology Corporation Semiconductor home page (<http://www.renesas.com>).
4. When using any or all of the information contained in these materials, including product data, diagrams, charts, programs, and algorithms, please be sure to evaluate all information as a total system before making a final decision on the applicability of the information and products. Renesas Technology Corporation assumes no responsibility for any damage, liability or other loss resulting from the information contained herein.
5. Renesas Technology Corporation semiconductors are not designed or manufactured for use in a device or system that is used under circumstances in which human life is potentially at stake. Please contact Renesas Technology Corporation or an authorized Renesas Technology Corporation product distributor when considering the use of a product contained herein for any specific purposes, such as apparatus or systems for transportation, vehicular, medical, aerospace, nuclear, or undersea repeater use.
6. The prior written approval of Renesas Technology Corporation is necessary to reprint or reproduce in whole or in part these materials.
7. If these products or technologies are subject to the Japanese export control restrictions, they must be exported under a license from the Japanese government and cannot be imported into a country other than the approved destination.
Any diversion or reexport contrary to the export control laws and regulations of Japan and/or the country of destination is prohibited.
8. Please contact Renesas Technology Corporation for further details on these materials or the products contained therein.

H8S/2355 Series

HD6432355, HD6472355

H8S/2353

HD6432353

H8S/2393

HD6432393

Hardware Manual



ADE-602-112B

Rev. 3.0

3/11/03

Hitachi, Ltd

Cautions

1. Hitachi neither warrants nor grants licenses of any rights of Hitachi's or any third party's patent, copyright, trademark, or other intellectual property rights for information contained in this document. Hitachi bears no responsibility for problems that may arise with third party's rights, including intellectual property rights, in connection with use of the information contained in this document.
2. Products and product specifications may be subject to change without notice. Confirm that you have received the latest product standards or specifications before final design, purchase or use.
3. Hitachi makes every attempt to ensure that its products are of high quality and reliability. However, contact Hitachi's sales office before using the product in an application that demands especially high quality and reliability or where its failure or malfunction may directly threaten human life or cause risk of bodily injury, such as aerospace, aeronautics, nuclear power, combustion control, transportation, traffic, safety equipment or medical equipment for life support.
4. Design your application so that the product is used within the ranges guaranteed by Hitachi particularly for maximum rating, operating supply voltage range, heat radiation characteristics, installation conditions and other characteristics. Hitachi bears no responsibility for failure or damage when used beyond the guaranteed ranges. Even within the guaranteed ranges, consider normally foreseeable failure rates or failure modes in semiconductor devices and employ systemic measures such as fail-safes, so that the equipment incorporating Hitachi product does not cause bodily injury, fire or other consequential damage due to operation of the Hitachi product.
5. This product is not designed to be radiation resistant.
6. No one is permitted to reproduce or duplicate, in any form, the whole or part of this document without written approval from Hitachi.
7. Contact Hitachi's sales office for any questions regarding this document or Hitachi semiconductor products.

Preface

The H8S/2355 Series is a series of high-performance microcontrollers with a 32-bit H8S/2000 CPU core, and a set of on-chip supporting functions required for system configuration.

The H8S/2000 CPU can execute basic instructions in one state, and is provided with sixteen 16-bit general registers with a 32-bit internal configuration, and a concise and optimized instruction set. The CPU can handle a 16 Mbyte linear address space (architecturally 4 Gbytes). Programs based on the high-level language C can also be run efficiently.

The address space is divided into eight areas. The data bus width and access states can be selected for each of these areas, and various kinds of memory can be connected fast and easily.

On-chip memory consists of large-capacity ROM and RAM. PROM (ZTAT™*) and mask ROM versions are available, providing a quick and flexible response to conditions from ramp-up through full-scale volume production, even for applications with frequently changing specifications.

On-chip supporting functions include a 16-bit timer pulse unit (TPU), 8-bit timers, watchdog timer (WDT), serial communication interface (SCI), A/D converter, D/A converter, and I/O ports.

An on-chip data transfer controller (DTC) is also provided, enabling high-speed data transfer without CPU intervention.

Use of the H8S/2355 Series enables compact, high-performance systems to be implemented easily.

This manual describes the hardware of the H8S/2355 Series. Refer to the H8S/2600 Series and H8S/2000 Series Programming Manual for a detailed description of the instruction set.

Note: * ZTAT is a trademark of Hitachi, Ltd. There is no PROM version of the H8S/2393.

Main Revisions and Additions in This Edition

Page	Section	Revision Contents															
All		H8S/2393 added															
4	Table 1-1 Overview Product lineup	[Amendments] Amendments associated with H8S/2393 addition															
6	Figure 1-2 Block Diagram (H8S/2393)	[Addition]															
9, 10	Figure 1-5 H8S/2393 Pin Arrangement (TFP-120: Top View) Figure 1-6 H8S/2393 Pin Arrangement (TFP-128: Top View)	[Addition]															
81, 82	Figure 3-3 Memory Map in Each Operating Mode in the H8S/2393	[Addition]															
225	8.5.1 Overview (Port 4)	[Amendment] Port 4 pins also function as A/D converter analog input pins (AN0 to AN7) in the H8S/2393.															
421	Table 12-3 BRR Settings for Various Bit Rates (Asynchronous Mode) Bit Rate: 38400	[Amendment] “Error” entries when $\phi = 4$ MHz amended to “_”.															
502	14.2.3 A/D Control Register (ADCR) Description of bits 7 and 6	[Amendment] <table border="1"> <thead> <tr> <th>Bit 7</th> <th>Bit 6</th> <th>Description</th> </tr> </thead> <tbody> <tr> <td>0</td> <td>0</td> <td>A/D conversion start by external trigger is disabled (Initial value)</td> </tr> <tr> <td></td> <td>1</td> <td>A/D conversion start by external trigger (TPU) is enabled</td> </tr> <tr> <td>1</td> <td>0</td> <td>A/D conversion start by external trigger (8-bit timer) is enabled</td> </tr> <tr> <td></td> <td>1</td> <td>A/D conversion start by external trigger pin (ADTRG) is enabled</td> </tr> </tbody> </table>	Bit 7	Bit 6	Description	0	0	A/D conversion start by external trigger is disabled (Initial value)		1	A/D conversion start by external trigger (TPU) is enabled	1	0	A/D conversion start by external trigger (8-bit timer) is enabled		1	A/D conversion start by external trigger pin (ADTRG) is enabled
Bit 7	Bit 6	Description															
0	0	A/D conversion start by external trigger is disabled (Initial value)															
	1	A/D conversion start by external trigger (TPU) is enabled															
1	0	A/D conversion start by external trigger (8-bit timer) is enabled															
	1	A/D conversion start by external trigger pin (ADTRG) is enabled															
	Table 14.6 Analog Pin Specifications	[Deletion]															
517	Section 15 D/A Converter	[Amendment] (Not supported in H8S/2393)															
533	Figure 17-2 Wiring of 120-Pin/32-Pin Socket Adapter Pin 4 of FP-128	[Amendment] Changed to “Open”.															
558	Table 19-3 MSTP Bits and Corresponding On-Chip Supporting Modules Bit MSTP10	[Addition] * In the H8S/2393 bit 10 can be read and written to but has no effect on operation, as a D/A converter is not supported.															

Page	Section	Revision Contents
570	Table 20-2 DC Characteristics (3)	[Additions] DC characteristics added for following conditions. Conditions: $V_{CC} = 3.0$ to 5.5 V, $AV_{CC} = 3.0$ to 5.5 V, $V_{ref} = 3.0$ V to AV_{CC} , $V_{SS} = AV_{SS} = 0$ V* ¹ , $T_a = -20$ to $+75^\circ\text{C}$ (regular specifications), $T_a = -40$ to $+85^\circ\text{C}$ (wide-range specifications)
574	Table 20-4 Clock Timing	[Additions]
576	Table 20-5 Control Signal Timing	Additions for Condition C
578	Table 20-6 Bus Timing	Condition C: (mask ROM version only)
586	Table 20-7 Timing of On-Chip Supporting Modules	$V_{CC} = 3.0$ to 5.5 V, $AV_{CC} = 3.0$ to 5.5 V, $V_{ref} = 3.0$ V to AV_{CC} , $V_{SS} = AV_{SS} = 0$ V, $\phi = 2$ to 13 MHz, $T_a = -20$ to $+75^\circ\text{C}$ (regular specifications), $T_a = -40$ to $+85^\circ\text{C}$ (wide-range specifications)
591	Table 20-8 A/D Conversion Characteristics	
592	Table 20-9 D/A Conversion Characteristics	
642	Table A-5 Number of Cycles in Instruction Execution EEPMOV instruction, Byte Data Access	[Amendments] $2n + 2$ * ² Note: 2. When n bytes of data are transferred.
672	B.1 Addresses H'FFA4 DADR0* ⁴ H'FFA5 DADR1* ⁴ H'FFA6 DACR* ⁴	[Amendments] Note: 4. In the H8S/2393 these bits are reserved, as a D/A converter is not supported.
781 to 785	Figure C-1 (a) Port 1 Block Diagram (Pins P1 ₀ , P1 ₁ , P1 ₄ and P1 ₆) Figure C-1 (b) Port 1 Block Diagram (Pins P1 ₂ , P1 ₃ , P1 ₅ , and P1 ₇) Figure C-2 (a) Port 2 Block Diagram (Pins P2 ₀ and P2 ₁) Figure C-2 (b) Port 2 Block Diagram (Pins P2 ₂ and P2 ₄) Figure C-2 (c) Port 2 Block Diagram (Pins P2 ₃ and P2 ₅)	[Deletion] Note: * Priority order: Output compare output/PWM output > DR output

Page	Section	Revision Contents
786	Figure C-2 (d) Port 2 Block Diagram (Pins P2 ₆ and P2 ₇)	[Deletion] Note: * Priority order: Output compare output/PWM output > compare match output > DR output
790	Figure C-4 (a) Port 4 Block Diagram	[Amendments] (Pins P4 ₀ to P4 ₅ in H8S/2355 and H8S/2353, Pins P4 ₀ to P4 ₇ in H8S/2393)
793	Figure C-5 (c) Port 5 Block Diagram (Pin P5 ₂)	[Deletion] Note: * Priority order: Serial clock input > serial clock output > DR output
821, 822	Appendix E Pin States at Power-On	[Additions]
824	Table G.1 H8S/2355 Series Product Code Lineup	[Amendments] Amendments associated with addition of H8S/2393

Contents

Section 1	Overview.....	1
1.1	Overview.....	1
1.2	Block Diagram	5
1.3	Pin Description.....	7
1.3.1	Pin Arrangement	7
1.3.2	Pin Functions in Each Operating Mode.....	11
1.3.3	Pin Functions	16
Section 2	CPU	23
2.1	Overview.....	23
2.1.1	Features	23
2.1.2	Differences between H8S/2600 CPU and H8S/2000 CPU	24
2.1.3	Differences from H8/300 CPU	25
2.1.4	Differences from H8/300H CPU	25
2.2	CPU Operating Modes	26
2.3	Address Space.....	31
2.4	Register Configuration	32
2.4.1	Overview.....	32
2.4.2	General Registers.....	33
2.4.3	Control Registers	34
2.4.4	Initial Register Values	36
2.5	Data Formats.....	37
2.5.1	General Register Data Formats.....	37
2.5.2	Memory Data Formats.....	39
2.6	Instruction Set	40
2.6.1	Overview.....	40
2.6.2	Instructions and Addressing Modes.....	41
2.6.3	Table of Instructions Classified by Function.....	43
2.6.4	Basic Instruction Formats	53
2.7	Addressing Modes and Effective Address Calculation.....	54
2.7.1	Addressing Mode.....	54
2.7.2	Effective Address Calculation	57
2.8	Processing States.....	61
2.8.1	Overview.....	61
2.8.2	Reset State	62
2.8.3	Exception-Handling State	63
2.8.4	Program Execution State	66
2.8.5	Bus-Released State.....	66
2.8.6	Power-Down State.....	66

2.9	Basic Timing.....	67
2.9.1	Overview.....	67
2.9.2	On-Chip Memory (ROM, RAM).....	67
2.9.3	On-Chip Supporting Module Access Timing.....	69
2.9.4	External Address Space Access Timing.....	70
Section 3 MCU Operating Modes.....		71
3.1	Overview.....	71
3.1.1	Operating Mode Selection.....	71
3.1.2	Register Configuration.....	72
3.2	Register Descriptions.....	72
3.2.1	Mode Control Register (MDCR).....	72
3.2.2	System Control Register (SYSCR).....	73
3.3	Operating Mode Descriptions.....	74
3.3.1	Mode 1.....	74
3.3.2	Mode 2.....	74
3.3.3	Mode 3.....	74
3.3.4	Mode 4.....	74
3.3.5	Mode 5.....	75
3.3.6	Mode 6.....	75
3.3.7	Mode 7.....	75
3.4	Pin Functions in Each Operating Mode.....	76
3.5	Memory Map in Each Operating Mode.....	76
Section 4 Exception Handling.....		83
4.1	Overview.....	83
4.1.1	Exception Handling Types and Priority.....	83
4.1.2	Exception Handling Operation.....	84
4.1.3	Exception Vector Table.....	84
4.2	Reset.....	86
4.2.1	Overview.....	86
4.2.2	Reset Types.....	86
4.2.3	Reset Sequence.....	87
4.2.4	Interrupts after Reset.....	88
4.2.5	State of On-Chip Supporting Modules after Reset Release.....	88
4.3	Traces.....	89
4.4	Interrupts.....	90
4.5	Trap Instruction.....	91
4.6	Stack Status after Exception Handling.....	92
4.7	Notes on Use of the Stack.....	93
Section 5 Interrupt Controller.....		95
5.1	Overview.....	95

5.1.1	Features	95
5.1.2	Block Diagram.....	96
5.1.3	Pin Configuration.....	97
5.1.4	Register Configuration.....	97
5.2	Register Descriptions	98
5.2.1	System Control Register (SYSCR).....	98
5.2.2	Interrupt Priority Registers A to K (IPRA to IPRK)	99
5.2.3	IRQ Enable Register (IER)	100
5.2.4	IRQ Sense Control Registers H and L (ISCRH, ISCLR)	101
5.2.5	IRQ Status Register (ISR)	102
5.3	Interrupt Sources.....	103
5.3.1	External Interrupts	103
5.3.2	Internal Interrupts.....	104
5.3.3	Interrupt Exception Handling Vector Table	104
5.4	Interrupt Operation.....	108
5.4.1	Interrupt Control Modes and Interrupt Operation	108
5.4.2	Interrupt Control Mode 0.....	111
5.4.3	Interrupt Control Mode 2.....	113
5.4.4	Interrupt Exception Handling Sequence	115
5.4.5	Interrupt Response Times	117
5.5	Usage Notes	118
5.5.1	Contention between Interrupt Generation and Disabling	118
5.5.2	Instructions that Disable Interrupts.....	119
5.5.3	Times when Interrupts are Disabled	119
5.5.4	Interrupts during Execution of EEPMOV Instruction	119
5.6	DTC Activation by Interrupt.....	120
5.6.1	Overview.....	120
5.6.2	Block Diagram.....	120
5.6.3	Operation	121
Section 6 Bus Controller		123
6.1	Overview.....	123
6.1.1	Features	123
6.1.2	Block Diagram.....	124
6.1.3	Pin Configuration.....	125
6.1.4	Register Configuration.....	125
6.2	Register Descriptions	126
6.2.1	Bus Width Control Register (ABWCR)	126
6.2.2	Access State Control Register (ASTCR).....	127
6.2.3	Wait Control Registers H and L (WCRH, WCRL)	128
6.2.4	Bus Control Register H (BCRH)	131
6.2.5	Bus Control Register L (BCRL)	133
6.3	Overview of Bus Control	134

6.3.1	Area Partitioning.....	134
6.3.2	Bus Specifications	136
6.3.3	Memory Interfaces.....	137
6.3.4	Advanced Mode.....	137
6.3.5	Areas in Normal Mode.....	138
6.3.6	Chip Select Signals	139
6.4	Basic Bus Interface	140
6.4.1	Overview.....	140
6.4.2	Data Size and Data Alignment.....	140
6.4.3	Valid Strobes.....	142
6.4.4	Basic Timing.....	143
6.4.5	Wait Control	151
6.5	Burst ROM Interface.....	153
6.5.1	Overview.....	153
6.5.2	Basic Timing.....	153
6.5.3	Wait Control.....	155
6.6	Idle Cycle	156
6.6.1	Operation	156
6.6.2	Pin States in Idle Cycle	159
6.7	Bus Release.....	160
6.7.1	Overview.....	160
6.7.2	Operation	160
6.7.3	Pin States in External Bus Released State	161
6.7.4	Transition Timing	162
6.7.5	Usage Note.....	163
6.8	Bus Arbitration.....	163
6.8.1	Overview.....	163
6.8.2	Operation	163
6.8.3	Bus Transfer Timing.....	164
6.8.4	External Bus Release Usage Note	164
6.9	Resets and the Bus Controller.....	164
Section 7 Data Transfer Controller		165
7.1	Overview.....	165
7.1.1	Features	165
7.1.2	Block Diagram.....	166
7.1.3	Register Configuration.....	167
7.2	Register Descriptions	168
7.2.1	DTC Mode Register A (MRA)	168
7.2.2	DTC Mode Register B (MRB).....	170
7.2.3	DTC Source Address Register (SAR)	171
7.2.4	DTC Destination Address Register (DAR)	171
7.2.5	DTC Transfer Count Register A (CRA)	171

7.2.6	DTC Transfer Count Register B (CRB).....	172
7.2.7	DTC Enable Registers (DTCER).....	172
7.2.8	DTC Vector Register (DTVECR)	173
7.2.9	Module Stop Control Register (MSTPCR).....	174
7.3	Operation.....	175
7.3.1	Overview	175
7.3.2	Activation Sources	177
7.3.3	DTC Vector Table	178
7.3.4	Location of Register Information in Address Space.....	181
7.3.5	Normal Mode	182
7.3.6	Repeat Mode	183
7.3.7	Block Transfer Mode.....	184
7.3.8	Chain Transfer	186
7.3.9	Operation Timing.....	187
7.3.10	Number of DTC Execution States	188
7.3.11	Procedures for Using DTC.....	190
7.3.12	Examples of Use of the DTC.....	191
7.4	Interrupts	193
7.5	Usage Notes	193
Section 8 I/O Ports		195
8.1	Overview	195
8.2	Port 1	200
8.2.1	Overview	200
8.2.2	Register Configuration.....	200
8.2.3	Pin Functions	202
8.3	Port 2.....	210
8.3.1	Overview	210
8.3.2	Register Configuration.....	210
8.3.3	Pin Functions	212
8.4	Port 3.....	220
8.4.1	Overview	220
8.4.2	Register Configuration.....	220
8.4.3	Pin Functions	223
8.5	Port 4.....	225
8.5.1	Overview	225
8.5.2	Register Configuration.....	226
8.5.3	Pin Functions	226
8.6	Port 5.....	227
8.6.1	Overview	227
8.6.2	Register Configuration.....	227
8.6.3	Pin Functions	230
8.7	Port 6.....	231

8.7.1	Overview.....	231
8.7.2	Register Configuration.....	232
8.7.3	Pin Functions	234
8.8	Port A.....	236
8.8.1	Overview.....	236
8.8.2	Register Configuration.....	237
8.8.3	Pin Functions	240
8.8.4	MOS Input Pull-Up Function.....	242
8.9	Port B.....	243
8.9.1	Overview.....	243
8.9.2	Register Configuration.....	244
8.9.3	Pin Functions	246
8.9.4	MOS Input Pull-Up Function.....	247
8.10	Port C.....	248
8.10.1	Overview.....	248
8.10.2	Register Configuration.....	249
8.10.3	Pin Functions	251
8.10.4	MOS Input Pull-Up Function.....	253
8.11	Port D.....	254
8.11.1	Overview.....	254
8.11.2	Register Configuration.....	255
8.11.3	Pin Functions	257
8.11.4	MOS Input Pull-Up Function.....	258
8.12	Port E.....	259
8.12.1	Overview.....	259
8.12.2	Register Configuration.....	260
8.12.3	Pin Functions	262
8.12.4	MOS Input Pull-Up Function.....	263
8.13	Port F.....	264
8.13.1	Overview.....	264
8.13.2	Register Configuration.....	265
8.13.3	Pin Functions	267
8.14	Port G.....	269
8.14.1	Overview.....	269
8.14.2	Register Configuration.....	270
8.14.3	Pin Functions	272
Section 9 16-Bit Timer Pulse Unit (TPU).....		275
9.1	Overview.....	275
9.1.1	Features	275
9.1.2	Block Diagram.....	279
9.1.3	Pin Configuration.....	280
9.1.4	Register Configuration.....	282

9.2	Register Descriptions	284
9.2.1	Timer Control Register (TCR).....	284
9.2.2	Timer Mode Register (TMDR).....	289
9.2.3	Timer I/O Control Register (TIOR).....	291
9.2.4	Timer Interrupt Enable Register (TIER).....	304
9.2.5	Timer Status Register (TSR)	307
9.2.6	Timer Counter (TCNT).....	310
9.2.7	Timer General Register (TGR)	311
9.2.8	Timer Start Register (TSTR)	312
9.2.9	Timer Synchro Register (TSYR)	313
9.2.10	Module Stop Control Register (MSTPCR).....	314
9.3	Interface to Bus Master.....	315
9.3.1	16-Bit Registers	315
9.3.2	8-Bit Registers	315
9.4	Operation.....	317
9.4.1	Overview	317
9.4.2	Basic Functions	318
9.4.3	Synchronous Operation	324
9.4.4	Buffer Operation	326
9.4.5	Cascaded Operation	330
9.4.6	PWM Modes	332
9.4.7	Phase Counting Mode	337
9.5	Interrupts	343
9.5.1	Interrupt Sources and Priorities	343
9.5.2	DTC Activation	345
9.5.3	A/D Converter Activation.....	345
9.6	Operation Timing	346
9.6.1	Input/Output Timing	346
9.6.2	Interrupt Signal Timing	350
9.7	Usage Notes	354
Section 10 8-Bit Timers.....		365
10.1	Overview.....	365
10.1.1	Features	365
10.1.2	Block Diagram.....	366
10.1.3	Pin Configuration.....	367
10.1.4	Register Configuration.....	367
10.2	Register Descriptions	368
10.2.1	Timer Counters 0 and 1 (TCNT0, TCNT1).....	368
10.2.2	Time Constant Registers A0 and A1 (TCORA0, TCORA1).....	368
10.2.3	Time Constant Registers B0 and B1 (TCORB0, TCORB1)	369
10.2.4	Time Control Registers 0 and 1 (TCR0, TCR1)	369
10.2.5	Timer Control/Status Registers 0 and 1 (TCSR0, TCSR1)	371

10.2.6	Module Stop Control Register (MSTPCR).....	374
10.3	Operation.....	375
10.3.1	TCNT Incrementation Timing.....	375
10.3.2	Compare Match Timing.....	376
10.3.3	Timing of External RESET on TCNT.....	378
10.3.4	Timing of Overflow Flag (OVF) Setting.....	378
10.3.5	Operation with Cascaded Connection.....	379
10.4	Interrupts.....	380
10.4.1	Interrupt Sources and DTC Activation.....	380
10.4.2	A/D Converter Activation.....	380
10.5	Sample Application.....	381
10.6	Usage Notes.....	382
10.6.1	Contention between TCNT Write and Clear.....	382
10.6.2	Contention between TCNT Write and Increment.....	383
10.6.3	Contention between TCOR Write and Compare Match.....	384
10.6.4	Contention between Compare Matches A and B.....	385
10.6.5	Switching of Internal Clocks and TCNT Operation.....	385
10.6.6	Usage Note.....	387
Section 11 Watchdog Timer.....		389
11.1	Overview.....	389
11.1.1	Features.....	389
11.1.2	Block Diagram.....	390
11.1.3	Pin Configuration.....	391
11.1.4	Register Configuration.....	391
11.2	Register Descriptions.....	392
11.2.1	Timer Counter (TCNT).....	392
11.2.2	Timer Control/Status Register (TCSR).....	392
11.2.3	Reset Control/Status Register (RSTCSR).....	394
11.2.4	Notes on Register Access.....	396
11.3	Operation.....	398
11.3.1	Watchdog Timer Operation.....	398
11.3.2	Interval Timer Operation.....	399
11.3.3	Timing of Setting Overflow Flag (OVF).....	399
11.3.4	Timing of Setting of Watchdog Timer Overflow Flag (WOVF).....	400
11.4	Interrupts.....	401
11.5	Usage Notes.....	401
11.5.1	Contention between Timer Counter (TCNT) Write and Increment.....	401
11.5.2	Changing Value of CKS2 to CKS0.....	401
11.5.3	Switching between Watchdog Timer Mode and Interval Timer Mode.....	402
11.5.4	System Reset by $\overline{\text{WDTOVF}}$ Signal.....	402
11.5.5	Internal Reset in Watchdog Timer Mode.....	402

Section 12	Serial Communication Interface (SCI)	403
12.1	Overview	403
12.1.1	Features	403
12.1.2	Block Diagram	405
12.1.3	Pin Configuration	406
12.1.4	Register Configuration	407
12.2	Register Descriptions	408
12.2.1	Receive Shift Register (RSR)	408
12.2.2	Receive Data Register (RDR)	408
12.2.3	Transmit Shift Register (TSR)	409
12.2.4	Transmit Data Register (TDR)	409
12.2.5	Serial Mode Register (SMR)	410
12.2.6	Serial Control Register (SCR)	413
12.2.7	Serial Status Register (SSR)	417
12.2.8	Bit Rate Register (BRR)	420
12.2.9	Smart Card Mode Register (SCMR)	429
12.2.10	Module Stop Control Register (MSTPCR)	430
12.3	Operation	431
12.3.1	Overview	431
12.3.2	Operation in Asynchronous Mode	433
12.3.3	Multiprocessor Communication Function	444
12.3.4	Operation in Clocked Synchronous Mode	452
12.4	SCI Interrupts	460
12.5	Usage Notes	462
Section 13	Smart Card Interface	467
13.1	Overview	467
13.1.1	Features	467
13.1.2	Block Diagram	468
13.1.3	Pin Configuration	469
13.1.4	Register Configuration	470
13.2	Register Descriptions	471
13.2.1	Smart Card Mode Register (SCMR)	471
13.2.2	Serial Status Register (SSR)	472
13.2.3	Serial Mode Register (SMR)	473
13.2.4	Serial Control Register (SCR)	474
13.3	Operation	475
13.3.1	Overview	475
13.3.2	Pin Connections	476
13.3.3	Data Format	477
13.3.4	Register Settings	479
13.3.5	Clock	481
13.3.6	Data Transfer Operations	483

13.3.7	Operation in GSM Mode	490
13.4	Usage Notes	491
Section 14	A/D Converter.....	495
14.1	Overview.....	495
14.1.1	Features	495
14.1.2	Block Diagram.....	496
14.1.3	Pin Configuration.....	497
14.1.4	Register Configuration.....	498
14.2	Register Descriptions	499
14.2.1	A/D Data Registers A to D (ADDRA to ADDR D).....	499
14.2.2	A/D Control/Status Register (ADCSR).....	500
14.2.3	A/D Control Register (ADCR)	502
14.2.4	Module Stop Control Register (MSTPCR).....	503
14.3	Interface to Bus Master.....	504
14.4	Operation.....	505
14.4.1	Single Mode (SCAN = 0)	505
14.4.2	Scan Mode (SCAN = 1).....	507
14.4.3	Input Sampling and A/D Conversion Time	509
14.4.4	External Trigger Input Timing.....	510
14.5	Interrupts	511
14.6	Usage Notes	511
Section 15	D/A Converter (Not supported in H8S/2393)	517
15.1	Overview.....	517
15.1.1	Features	517
15.1.2	Block Diagram.....	518
15.1.3	Pin Configuration.....	519
15.1.4	Register Configuration.....	519
15.2	Register Descriptions	520
15.2.1	D/A Data Registers 0 and 1 (DADR0, DADR1).....	520
15.2.2	D/A Control Register (DACR)	520
15.2.3	Module Stop Control Register (MSTPCR).....	522
15.3	Operation.....	523
Section 16	RAM.....	525
16.1	Overview.....	525
16.1.1	Block Diagram.....	525
16.1.2	Register Configuration.....	526
16.2	Register Descriptions	526
16.2.1	System Control Register (SYSCR).....	526
16.3	Operation.....	527
16.4	Usage Note.....	527

Section 17	ROM.....	529
17.1	Overview.....	529
17.1.1	Block Diagram.....	529
17.1.2	Register Configuration.....	530
17.2	Register Descriptions	530
17.2.1	Bus Control Register L (BCRL)	530
17.3	Operation.....	531
17.4	PROM Mode.....	532
17.4.1	PROM Mode Setting	532
17.4.2	Socket Adapter and Memory Map.....	532
17.5	Programming.....	535
17.5.1	Overview.....	535
17.5.2	Programming and Verification	535
17.5.3	Programming Precautions.....	540
17.5.4	Reliability of Programmed Data.....	541
Section 18	Clock Pulse Generator.....	543
18.1	Overview.....	543
18.1.1	Block Diagram.....	543
18.1.2	Register Configuration.....	543
18.2	Register Descriptions	544
18.2.1	System Clock Control Register (SCKCR).....	544
18.3	Oscillator.....	545
18.3.1	Connecting a Crystal Resonator.....	545
18.3.2	External Clock Input.....	547
18.4	Duty Adjustment Circuit.....	549
18.5	Medium-Speed Clock Divider	549
18.6	Bus Master Clock Selection Circuit.....	549
Section 19	Power-Down Modes	551
19.1	Overview.....	551
19.1.1	Register Configuration.....	552
19.2	Register Descriptions	553
19.2.1	Standby Control Register (SBYCR)	553
19.2.2	System Clock Control Register (SCKCR).....	554
19.2.3	Module Stop Control Register (MSTPCR).....	555
19.3	Medium-Speed Mode.....	556
19.4	Sleep Mode	557
19.5	Module Stop Mode	557
19.5.1	Module Stop Mode	557
19.5.2	Usage Notes.....	558
19.6	Software Standby Mode.....	559
19.6.1	Software Standby Mode.....	559

19.6.2	Clearing Software Standby Mode.....	559
19.6.3	Setting Oscillation Stabilization Time after Clearing Software Standby Mode ...	560
19.6.4	Software Standby Mode Application Example	560
19.6.5	Usage Notes	561
19.7	Hardware Standby Mode	562
19.7.1	Hardware Standby Mode	562
19.7.2	Hardware Standby Mode Timing.....	562
19.8	∅ Clock Output Disabling Function	563
Section 20 Electrical Characteristics		565
20.1	Absolute Maximum Ratings	565
20.2	DC Characteristics	566
20.3	AC Characteristics	573
20.3.1	Clock Timing	574
20.3.2	Control Signal Timing	576
20.3.3	Bus Timing	578
20.3.4	Timing of On-Chip Supporting Modules.....	586
20.4	A/D Conversion Characteristics	591
20.5	D/A Conversion Characteristics	592
20.6	Usage Note	592
Appendix A Instruction Set		593
A.1	Instruction List	593
A.2	Instruction Codes	617
A.3	Operation Code Map.....	632
A.4	Number of States Required for Instruction Execution.....	636
A.5	Bus States During Instruction Execution	647
A.6	Condition Code Modification	661
Appendix B Internal I/O Register.....		667
B.1	Addresses	667
B.2	Functions.....	674
Appendix C I/O Port Block Diagrams		781
C.1	Port 1 Block Diagram	781
C.2	Port 2 Block Diagram	783
C.3	Port 3 Block Diagram	787
C.4	Port 4 Block Diagram	790
C.5	Port 5 Block Diagram	791
C.6	Port 6 Block Diagram	795
C.7	Port A Block Diagram.....	799
C.8	Port B Block Diagram.....	802
C.9	Port C Block Diagram.....	803

C.10	Port D Block Diagram.....	804
C.11	Port E Block Diagram.....	805
C.12	Port F Block Diagram.....	806
C.13	Port G Block Diagram.....	814
Appendix D Pin States		817
D.1	Port States in Each Mode.....	817
Appendix E Pin States at Power-On.....		821
E.1	When Pins Settle from an Indeterminate State at Power-On.....	821
E.2	When Pins Settle from the High-Impedance State at Power-On	822
Appendix F Timing of Transition to and Recovery from Hardware Standby Mode		823
Appendix G Product Code Lineup		824
Appendix H Package Dimensions		825

Section 1 Overview

1.1 Overview

The H8S/2355 Series is a series of microcomputers (MCUs: microcomputer units), built around the H8S/2000 CPU, employing Hitachi's proprietary architecture, and equipped with peripheral functions on-chip.

The H8S/2000 CPU has an internal 32-bit architecture, is provided with sixteen 16-bit general registers and a concise, optimized instruction set designed for high-speed operation, and can address a 16-Mbyte linear address space. The instruction set is upward-compatible with H8/300 and H8/300H CPU instructions at the object-code level, facilitating migration from the H8/300, H8/300L, or H8/300H Series.

On-chip peripheral functions required for system configuration include data transfer controller (DTC) bus masters, ROM and RAM memory, a 16-bit timer-pulse unit (TPU), 8-bit timer, watchdog timer (WDT), serial communication interface (SCI), A/D converter, D/A converter*¹, and I/O ports.

The on-chip ROM is either PROM (ZTAT^{TM*2}) or mask ROM, with a capacity of 128, 64 or 32 kbytes. ROM is connected to the CPU via a 16-bit data bus, enabling both byte and word data to be accessed in one state. Instruction fetching has been speeded up, and processing speed increased.

Seven operating modes, modes 1 to 7, are provided, and there is a choice of address space and single-chip mode or external expansion mode.

The features of the H8S/2355 Series are shown in Table 1-1.

- Notes: 1. The H8S/2393 does not support a D/A converter.
2. ZTAT is a trademark of Hitachi, Ltd.

Table 1-1 Overview

Item	Specification
CPU	<ul style="list-style-type: none"> • General-register machine <ul style="list-style-type: none"> — Sixteen 16-bit general registers (also usable as sixteen 8-bit registers or eight 32-bit registers) • High-speed operation suitable for realtime control <ul style="list-style-type: none"> — Maximum clock rate: 20 MHz — High-speed arithmetic operations <ul style="list-style-type: none"> 8/16/32-bit register-register add/subtract : 50 ns 16 × 16-bit register-register multiply : 1000 ns 32 ÷ 16-bit register-register divide : 1000 ns • Instruction set suitable for high-speed operation <ul style="list-style-type: none"> — Sixty-five basic instructions — 8/16/32-bit move/arithmetic and logic instructions — Unsigned/signed multiply and divide instructions — Powerful bit-manipulation instructions • Two CPU operating modes <ul style="list-style-type: none"> — Normal mode : 64-kbyte address space — Advanced mode : 16-Mbyte address space
Bus controller	<ul style="list-style-type: none"> • Address space divided into 8 areas, with bus specifications settable independently for each area • Chip select output possible for each area • Choice of 8-bit or 16-bit access space for each area • 2-state or 3-state access space can be designated for each area • Number of program wait states can be set for each area • Burst ROM directly connectable • External bus release function
Data transfer controller (DTC)	<ul style="list-style-type: none"> • Can be activated by internal interrupt or software • Multiple transfers or multiple types of transfer possible for one activation source • Transfer possible in repeat mode, block transfer mode, etc. • Request can be sent to CPU for interrupt that activated DTC
16-bit timer-pulse unit (TPU)	<ul style="list-style-type: none"> • 6-channel 16-bit timer on-chip • Pulse I/O processing capability for up to 16 pins' • Automatic 2-phase encoder count capability

Item	Specification												
8-bit timer 2 channels	<ul style="list-style-type: none"> • 8-bit up-counter (external event count capability) • Two time constant registers • Two-channel connection possible 												
Watchdog timer	<ul style="list-style-type: none"> • Watchdog timer or interval timer selectable 												
Serial communication interface (SCI) 3 channels	<ul style="list-style-type: none"> • Asynchronous mode or synchronous mode selectable • Multiprocessor communication function • Smart card interface function 												
A/D converter	<ul style="list-style-type: none"> • Resolution: 10 bits • Input: 8 channels • High-speed conversion: 6.7 μs minimum conversion time (at 20 MHz operation) • Single or scan mode selectable • Sample and hold circuit • A/D conversion can be activated by external trigger or timer trigger 												
D/A converter*	<ul style="list-style-type: none"> • Resolution: 8 bits • Output: 2 channels 												
I/O ports	<ul style="list-style-type: none"> • 87 I/O pins, 8 input-only pins 												
Memory	<ul style="list-style-type: none"> • PROM or mask ROM • High-speed static RAM 												
	<table border="1"> <thead> <tr> <th>Product Name</th> <th>ROM</th> <th>RAM</th> </tr> </thead> <tbody> <tr> <td>H8S/2355</td> <td>128 kbytes</td> <td>4 kbytes</td> </tr> <tr> <td>H8S/2353</td> <td>64 kbytes</td> <td>2 kbytes</td> </tr> <tr> <td>H8S/2393</td> <td>32 kbytes</td> <td>4 kbytes</td> </tr> </tbody> </table>	Product Name	ROM	RAM	H8S/2355	128 kbytes	4 kbytes	H8S/2353	64 kbytes	2 kbytes	H8S/2393	32 kbytes	4 kbytes
Product Name	ROM	RAM											
H8S/2355	128 kbytes	4 kbytes											
H8S/2353	64 kbytes	2 kbytes											
H8S/2393	32 kbytes	4 kbytes											
Interrupt controller	<ul style="list-style-type: none"> • Nine external interrupt pins (NMI, $\overline{\text{IRQ0}}$ to $\overline{\text{IRQ7}}$) • 47 internal interrupt sources • Eight priority levels settable 												
Power-down state	<ul style="list-style-type: none"> • Medium-speed mode • Sleep mode • Module stop mode • Software standby mode • Hardware standby mode 												

Item	Specification					
Operating modes	Seven MCU operating modes					
		CPU Operating Mode		On-Chip ROM	External Data Bus	
	Mode	Mode	Description		Initial Value	Maximum Value
	1	Normal	On-chip ROM disabled expansion mode	Disabled	8 bits	16 bits
	2		On-chip ROM enabled expansion mode	Enabled	8 bits	16 bits
	3		Single-chip mode	Enabled	—	
	4	Advanced	On-chip ROM disabled expansion mode	Disabled	16 bits	16 bits
	5		On-chip ROM disabled expansion mode	Disabled	8 bits	16 bits
6		On-chip ROM enabled expansion mode	Enabled	8 bits	16 bits	
7		Single-chip mode	Enabled	—		

Clock pulse generator

- Built-in duty correction circuit

Packages

- 120-pin plastic TQFP (TFP-120)
- 128-pin plastic QFP (FP-128)

Product Lineup		5 V Version	3.3 V Version*	3 V Version	ROM/RAM (bytes)
Operating power supply voltage		5 V ± 10 %	3.0 V to 5.5 V	2.7 V to 5.5 V	
Operating frequency		2 to 20 MHz	2 to 13 MHz	2 to 10 MHz	
Model Name	ZTAT™	HD6472355F20 HD6472355TE20	— —	HD6472355F10 HD6472355TE10	128 k/4 k
Mask ROM Version		HD6432355(A**)F HD6432355(A**)TE HD6432353(A**)F HD6432353(A**)TE HD6432393(A**)F HD6432393(A**)TE	HD6432355(M**)F HD6432355(M**)TE HD6432353(M**)F HD6432353(M**)TE HD6432393(M**)F HD6432393(M**)TE	HD6432355(K**)F HD6432355(K**)TE HD6432353(K**)F HD6432353(K**)TE HD6432393(K**)F HD6432393(K**)TE	128 k/4 k 64 k/2 k 32 k/4 k
Packages		FP-128 TFP-120	FP-128 TFP-120	FP-128 TFP-120	

Notes: 1. With the mask ROM version, (**) is the ROM code.
2. Please contact Hitachi Sales for information on the 3.3 V version.

Note: The H8S/2393 does not support a D/A converter.

1.2 Block Diagram

Figure 1-1 and figure 1-2 show a internal block diagrams of the H8S/2355 and H8S/2353, and the H8S/2393.

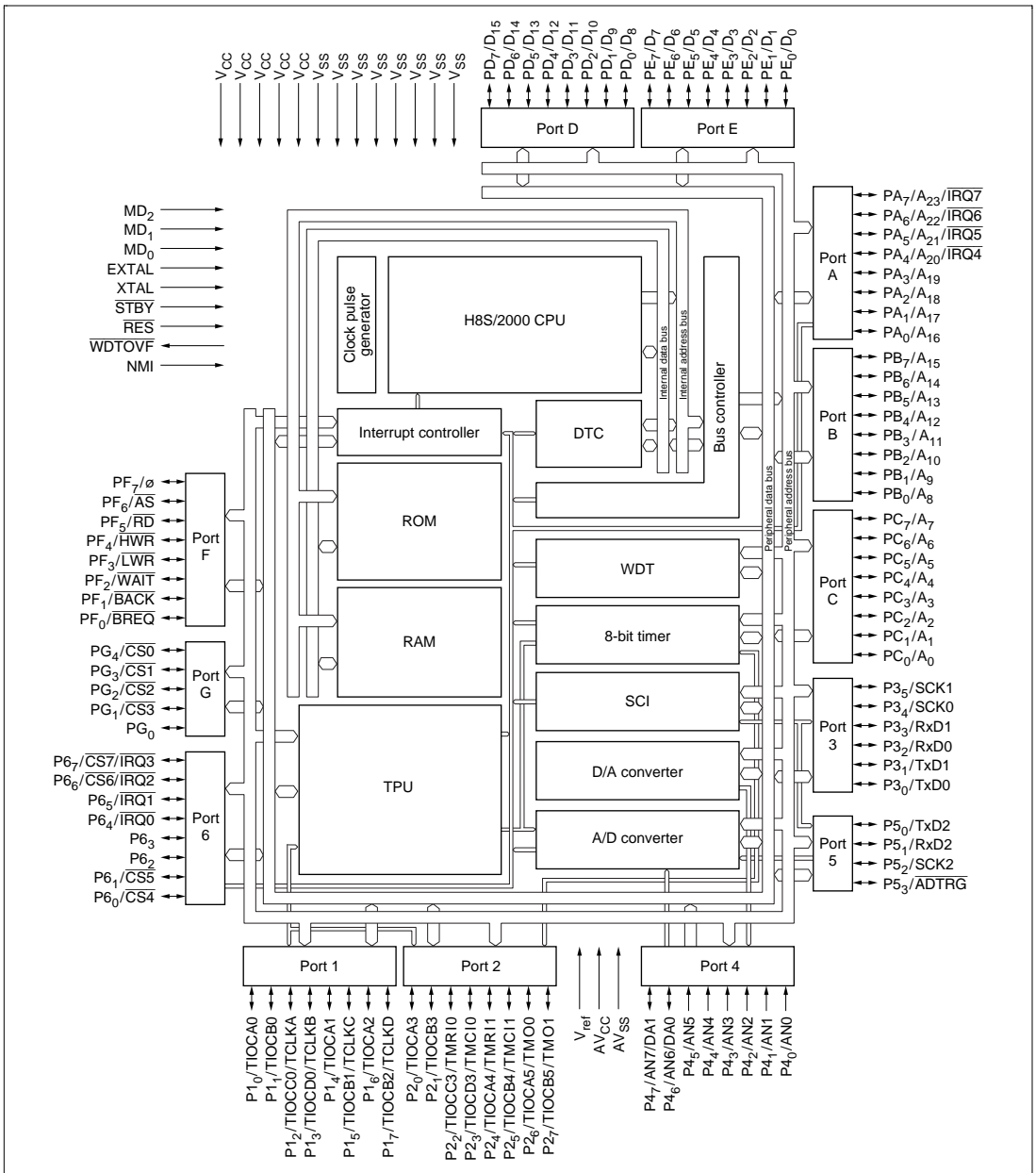

Figure 1-1 Block Diagram (H8S/2355, H8S/2353)

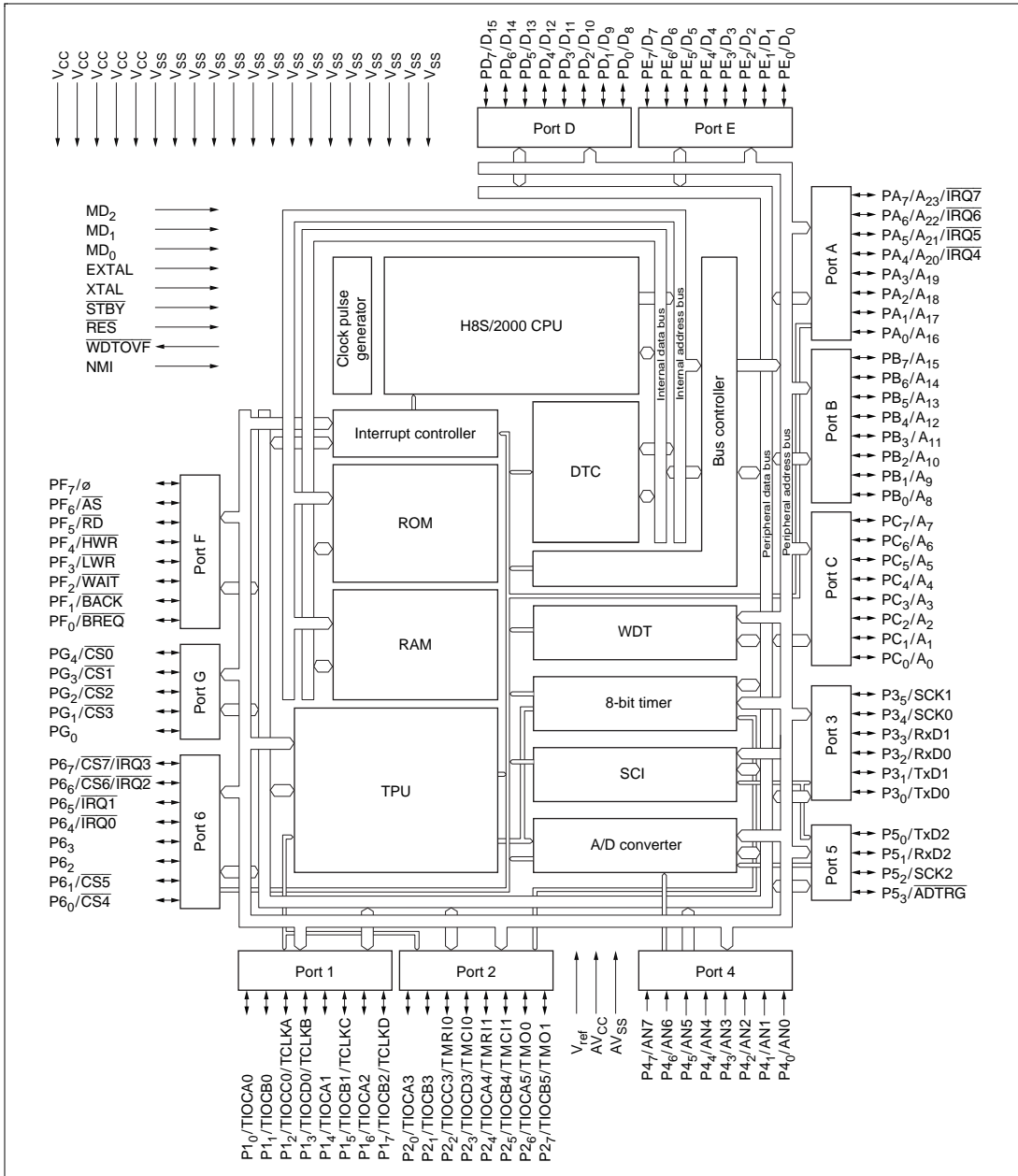

Figure 1-2 Block Diagram (H8S/2393)

1.3 Pin Description

1.3.1 Pin Arrangement

Figures 1-3 and 1-4 show the pin arrangement of the H8S/2355 and H8S/2353, and figure 1-5 and 1-6 show the pin arrangement of the H8S/2393.

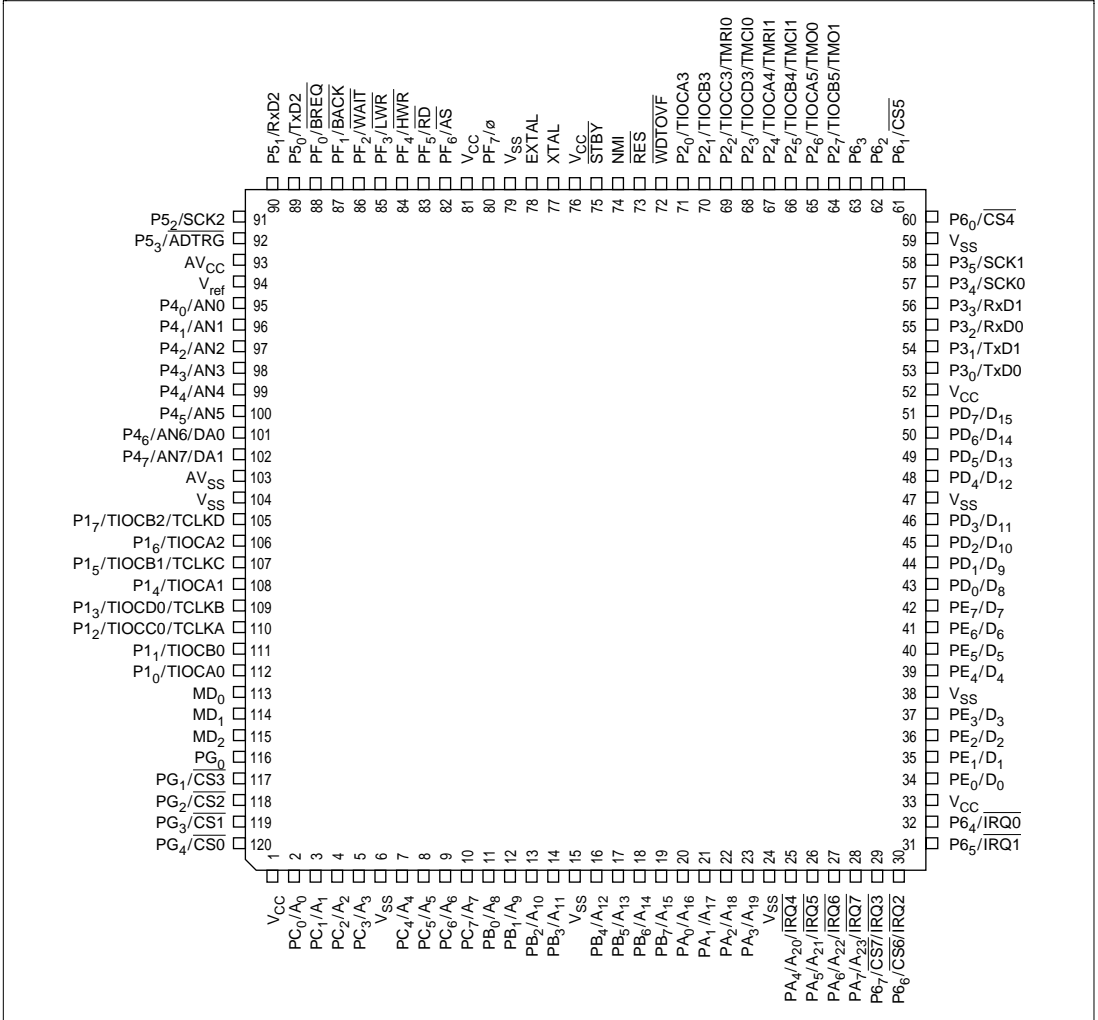

Figure 1-3 H8S/2355 and H8S/2353 Pin Arrangement (TFP-120: Top View)

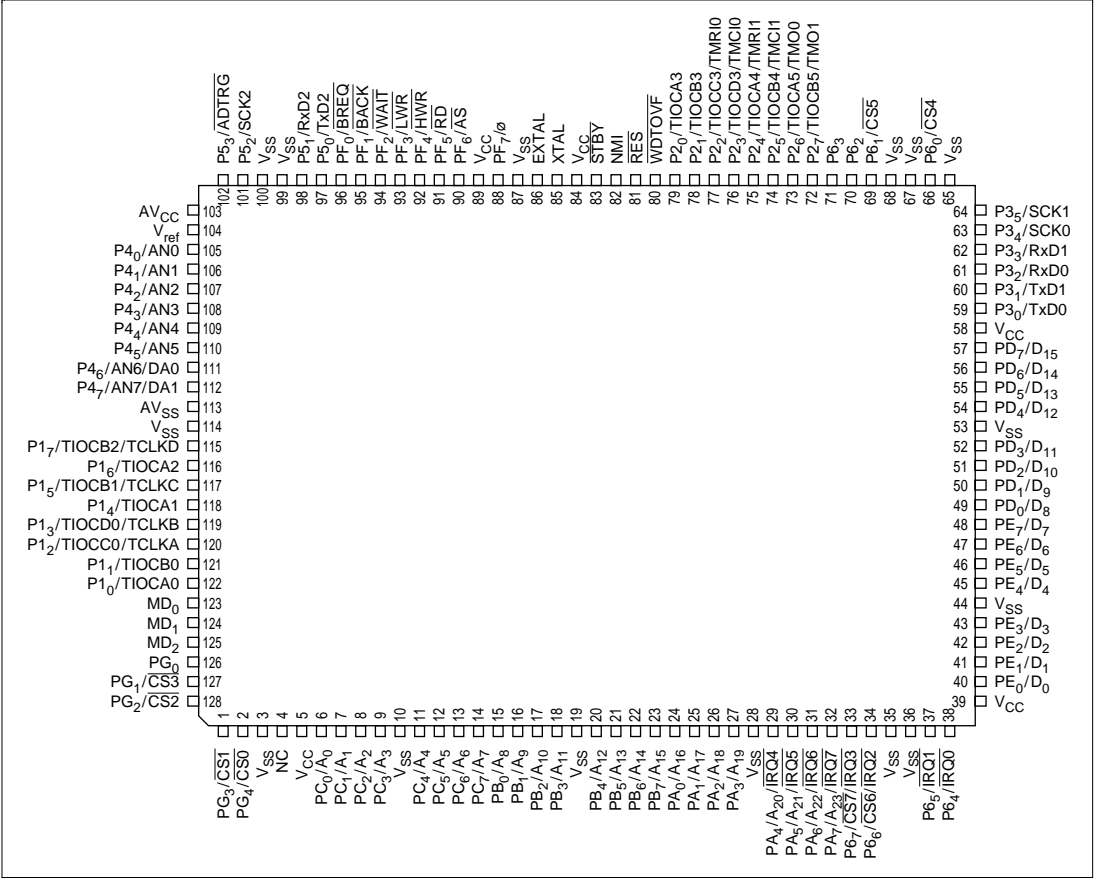

Figure 1-4 H8S/2355 and H8S/2353 Pin Arrangement (FP-128: Top View)

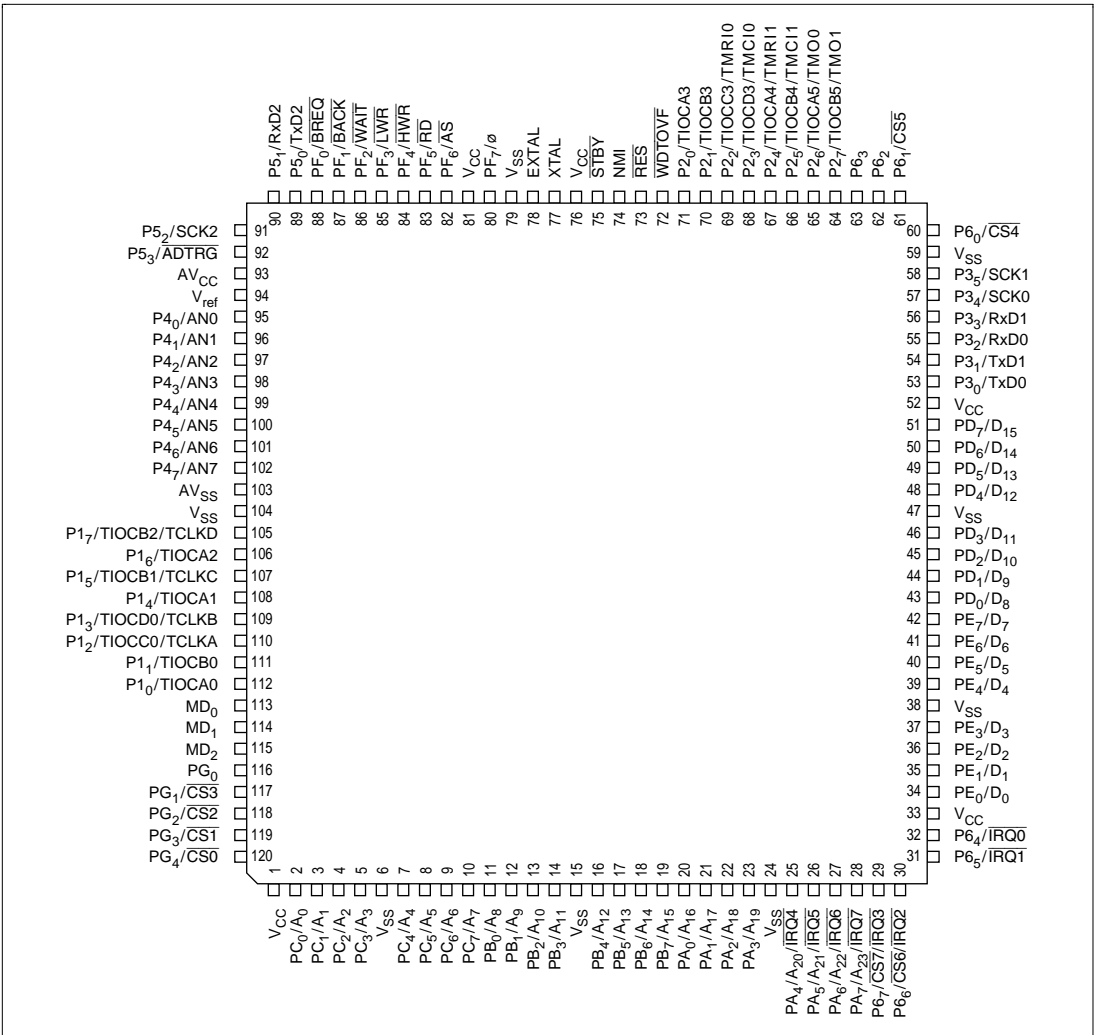

Figure 1-5 H8S/2393 Pin Arrangement (TFP-120: Top View)

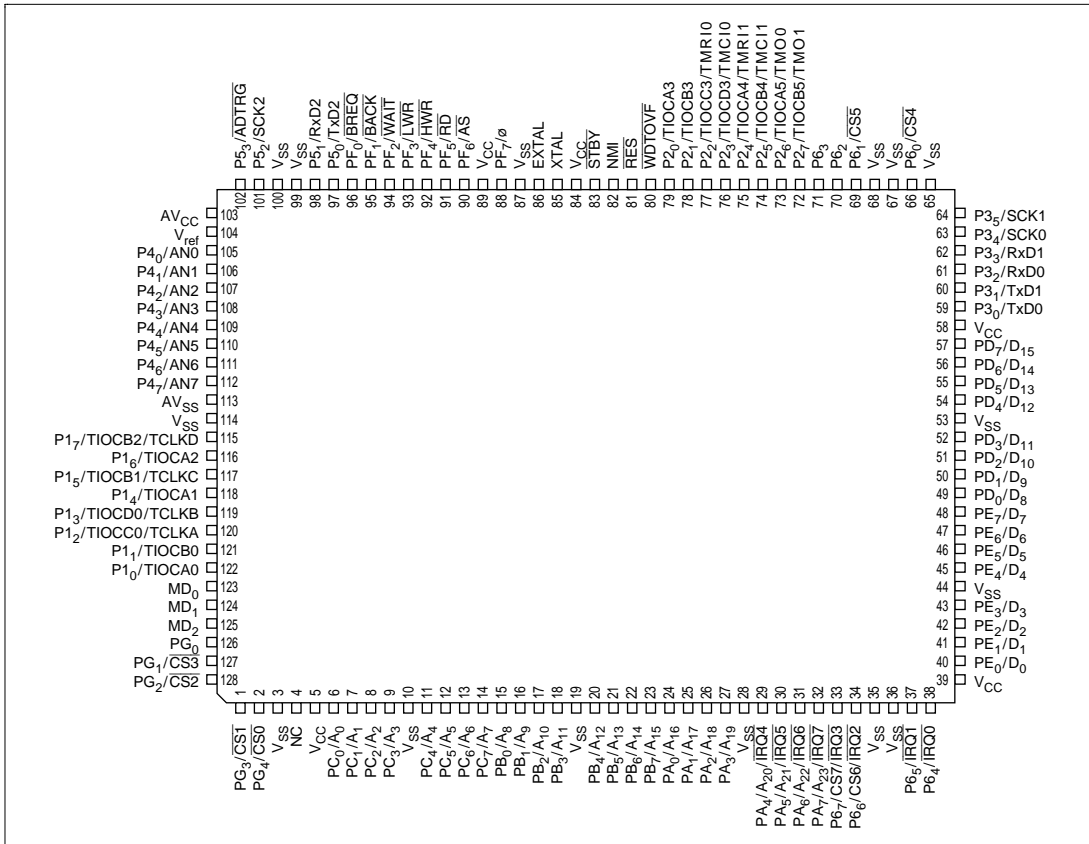

Figure 1-6 H8S/2393 Pin Arrangement (FP-128: Top View)

1.3.2 Pin Functions in Each Operating Mode

Table 1-2 shows the pin functions of the H8S/2355 Series in each of the operating modes.

Table 1-2 Pin Functions in Each Operating Mode

Pin No.		Pin Name							PROM*1
TFP-120	FP-128	Mode 1	Mode 2	Mode 3	Mode 4	Mode 5	Mode 6	Mode 7	Mode
1	5	V _{CC}	V _{CC}	V _{CC}	V _{CC}	V _{CC}	V _{CC}	V _{CC}	V _{CC}
2	6	A ₀	PC ₀ /A ₀	PC ₀	A ₀	A ₀	PC ₀ /A ₀	PC ₀	A ₀
3	7	A ₁	PC ₁ /A ₁	PC ₁	A ₁	A ₁	PC ₁ /A ₁	PC ₁	A ₁
4	8	A ₂	PC ₂ /A ₂	PC ₂	A ₂	A ₂	PC ₂ /A ₂	PC ₂	A ₂
5	9	A ₃	PC ₃ /A ₃	PC ₃	A ₃	A ₃	PC ₃ /A ₃	PC ₃	A ₃
6	10	V _{SS}	V _{SS}	V _{SS}	V _{SS}	V _{SS}	V _{SS}	V _{SS}	V _{SS}
7	11	A ₄	PC ₄ /A ₄	PC ₄	A ₄	A ₄	PC ₄ /A ₄	PC ₄	A ₄
8	12	A ₅	PC ₅ /A ₅	PC ₅	A ₅	A ₅	PC ₅ /A ₅	PC ₅	A ₅
9	13	A ₆	PC ₆ /A ₆	PC ₆	A ₆	A ₆	PC ₆ /A ₆	PC ₆	A ₆
10	14	A ₇	PC ₇ /A ₇	PC ₇	A ₇	A ₇	PC ₇ /A ₇	PC ₇	A ₇
11	15	A ₈	PB ₀ /A ₈	PB ₀	A ₈	A ₈	PB ₀ /A ₈	PB ₀	A ₈
12	16	A ₉	PB ₁ /A ₉	PB ₁	A ₉	A ₉	PB ₁ /A ₉	PB ₁	\overline{OE}
13	17	A ₁₀	PB ₂ /A ₁₀	PB ₂	A ₁₀	A ₁₀	PB ₂ /A ₁₀	PB ₂	A ₁₀
14	18	A ₁₁	PB ₃ /A ₁₁	PB ₃	A ₁₁	A ₁₁	PB ₃ /A ₁₁	PB ₃	A ₁₁
15	19	V _{SS}	V _{SS}	V _{SS}	V _{SS}	V _{SS}	V _{SS}	V _{SS}	V _{SS}
16	20	A ₁₂	PB ₄ /A ₁₂	PB ₄	A ₁₂	A ₁₂	PB ₄ /A ₁₂	PB ₄	A ₁₂
17	21	A ₁₃	PB ₅ /A ₁₃	PB ₅	A ₁₃	A ₁₃	PB ₅ /A ₁₃	PB ₅	A ₁₃
18	22	A ₁₄	PB ₆ /A ₁₄	PB ₆	A ₁₄	A ₁₄	PB ₆ /A ₁₄	PB ₆	A ₁₄
19	23	A ₁₅	PB ₇ /A ₁₅	PB ₇	A ₁₅	A ₁₅	PB ₇ /A ₁₅	PB ₇	A ₁₅
20	24	PA ₀	PA ₀	PA ₀	A ₁₆	A ₁₆	PA ₀ /A ₁₆	PA ₀	A ₁₆
21	25	PA ₁	PA ₁	PA ₁	A ₁₇	A ₁₇	PA ₁ /A ₁₇	PA ₁	V _{CC}
22	26	PA ₂	PA ₂	PA ₂	A ₁₈	A ₁₈	PA ₂ /A ₁₈	PA ₂	V _{CC}
23	27	PA ₃	PA ₃	PA ₃	A ₁₉	A ₁₉	PA ₃ /A ₁₉	PA ₃	NC
24	28	V _{SS}	V _{SS}	V _{SS}	V _{SS}	V _{SS}	V _{SS}	V _{SS}	V _{SS}
25	29	PA ₄ /IRQ4	PA ₄ /IRQ4	PA ₄ /IRQ4	A ₂₀	A ₂₀	PA ₄ /A ₂₀ / IRQ4	PA ₄ /IRQ4	NC
26	30	PA ₅ /IRQ5	PA ₅ /IRQ5	PA ₅ /IRQ5	PA ₅ /A ₂₁ / IRQ5	PA ₅ /A ₂₁ / IRQ5	PA ₅ /A ₂₁ / IRQ5	PA ₅ /IRQ5	NC
27	31	PA ₆ /IRQ6	PA ₆ /IRQ6	PA ₆ /IRQ6	PA ₆ /A ₂₂ / IRQ6	PA ₆ /A ₂₂ / IRQ6	PA ₆ /A ₂₂ / IRQ6	PA ₆ /IRQ6	NC

Pin No.		Pin Name							PROM*1
TFP-120	FP-128	Mode 1	Mode 2	Mode 3	Mode 4	Mode 5	Mode 6	Mode 7	Mode
28	32	PA ₇ /IRQ7	PA ₇ /IRQ7	PA ₇ /IRQ7	PA ₇ /A ₂₃ /IRQ7	PA ₇ /A ₂₃ /IRQ7	PA ₇ /A ₂₃ /IRQ7	PA ₇ /IRQ7	NC
29	33	P6 ₇ /IRQ3	P6 ₇ /IRQ3	P6 ₇ /IRQ3	P6 ₇ /IRQ3/CS7	P6 ₇ /IRQ3/CS7	P6 ₇ /IRQ3/CS7	P6 ₇ /IRQ3	NC
30	34	P6 ₆ /IRQ2	P6 ₆ /IRQ2	P6 ₆ /IRQ2	P6 ₆ /IRQ2/CS6	P6 ₆ /IRQ2/CS6	P6 ₆ /IRQ2/CS6	P6 ₆ /IRQ2	NC
—	35	V _{SS}	V _{SS}	V _{SS}	V _{SS}	V _{SS}	V _{SS}	V _{SS}	V _{SS}
—	36	V _{SS}	V _{SS}	V _{SS}	V _{SS}	V _{SS}	V _{SS}	V _{SS}	V _{SS}
31	37	P6 ₅ /IRQ1	P6 ₅ /IRQ1	P6 ₅ /IRQ1	P6 ₅ /IRQ1	P6 ₅ /IRQ1	P6 ₅ /IRQ1	P6 ₅ /IRQ1	NC
32	38	P6 ₄ /IRQ0	P6 ₄ /IRQ0	P6 ₄ /IRQ0	P6 ₄ /IRQ0	P6 ₄ /IRQ0	P6 ₄ /IRQ0	P6 ₄ /IRQ0	NC
33	39	V _{CC}	V _{CC}	V _{CC}	V _{CC}	V _{CC}	V _{CC}	V _{CC}	V _{CC}
34	40	PE ₀ /D ₀	PE ₀ /D ₀	PE ₀	PE ₀ /D ₀	PE ₀ /D ₀	PE ₀ /D ₀	PE ₀	NC
35	41	PE ₁ /D ₁	PE ₁ /D ₁	PE ₁	PE ₁ /D ₁	PE ₁ /D ₁	PE ₁ /D ₁	PE ₁	NC
36	42	PE ₂ /D ₂	PE ₂ /D ₂	PE ₂	PE ₂ /D ₂	PE ₂ /D ₂	PE ₂ /D ₂	PE ₂	NC
37	43	PE ₃ /D ₃	PE ₃ /D ₃	PE ₃	PE ₃ /D ₃	PE ₃ /D ₃	PE ₃ /D ₃	PE ₃	NC
38	44	V _{SS}	V _{SS}	V _{SS}	V _{SS}	V _{SS}	V _{SS}	V _{SS}	V _{SS}
39	45	PE ₄ /D ₄	PE ₄ /D ₄	PE ₄	PE ₄ /D ₄	PE ₄ /D ₄	PE ₄ /D ₄	PE ₄	NC
40	46	PE ₅ /D ₅	PE ₅ /D ₅	PE ₅	PE ₅ /D ₅	PE ₅ /D ₅	PE ₅ /D ₅	PE ₅	NC
41	47	PE ₆ /D ₆	PE ₆ /D ₆	PE ₆	PE ₆ /D ₆	PE ₆ /D ₆	PE ₆ /D ₆	PE ₆	NC
42	48	PE ₇ /D ₇	PE ₇ /D ₇	PE ₇	PE ₇ /D ₇	PE ₇ /D ₇	PE ₇ /D ₇	PE ₇	NC
43	49	D ₈	D ₈	PD ₀	D ₈	D ₈	D ₈	PD ₀	D ₀
44	50	D ₉	D ₉	PD ₁	D ₉	D ₉	D ₉	PD ₁	D ₁
45	51	D ₁₀	D ₁₀	PD ₂	D ₁₀	D ₁₀	D ₁₀	PD ₂	D ₂
46	52	D ₁₁	D ₁₁	PD ₃	D ₁₁	D ₁₁	D ₁₁	PD ₃	D ₃
47	53	V _{SS}	V _{SS}	V _{SS}	V _{SS}	V _{SS}	V _{SS}	V _{SS}	V _{SS}
48	54	D ₁₂	D ₁₂	PD ₄	D ₁₂	D ₁₂	D ₁₂	PD ₄	D ₄
49	55	D ₁₃	D ₁₃	PD ₅	D ₁₃	D ₁₃	D ₁₃	PD ₅	D ₅
50	56	D ₁₄	D ₁₄	PD ₆	D ₁₄	D ₁₄	D ₁₄	PD ₆	D ₆
51	57	D ₁₅	D ₁₅	PD ₇	D ₁₅	D ₁₅	D ₁₅	PD ₇	D ₇
52	58	V _{CC}	V _{CC}	V _{CC}	V _{CC}	V _{CC}	V _{CC}	V _{CC}	V _{CC}
53	59	P3 ₀ /TxD0	P3 ₀ /TxD0	P3 ₀ /TxD0	P3 ₀ /TxD0	P3 ₀ /TxD0	P3 ₀ /TxD0	P3 ₀ /TxD0	NC
54	60	P3 ₁ /TxD1	P3 ₁ /TxD1	P3 ₁ /TxD1	P3 ₁ /TxD1	P3 ₁ /TxD1	P3 ₁ /TxD1	P3 ₁ /TxD1	NC
55	61	P3 ₂ /RxD0	P3 ₂ /RxD0	P3 ₂ /RxD0	P3 ₂ /RxD0	P3 ₂ /RxD0	P3 ₂ /RxD0	P3 ₂ /RxD0	NC

Pin No.		Pin Name							PROM*1
TFP-120	FP-128	Mode 1	Mode 2	Mode 3	Mode 4	Mode 5	Mode 6	Mode 7	Mode
56	62	P3 ₃ /RxD1	P3 ₃ /RxD1	P3 ₃ /RxD1	P3 ₃ /RxD1	P3 ₃ /RxD1	P3 ₃ /RxD1	P3 ₃ /RxD1	NC
57	63	P3 ₄ /SCK0	P3 ₄ /SCK0	P3 ₄ /SCK0	P3 ₄ /SCK0	P3 ₄ /SCK0	P3 ₄ /SCK0	P3 ₄ /SCK0	NC
58	64	P3 ₅ /SCK1	P3 ₅ /SCK1	P3 ₅ /SCK1	P3 ₅ /SCK1	P3 ₅ /SCK1	P3 ₅ /SCK1	P3 ₅ /SCK1	NC
59	65	V _{SS}	V _{SS}	V _{SS}	V _{SS}	V _{SS}	V _{SS}	V _{SS}	V _{SS}
60	66	P6 ₀	P6 ₀	P6 ₀	P6 ₀ / CS4	P6 ₀ / CS4	P6 ₀ / CS4	P6 ₀	NC
—	67	V _{SS}	V _{SS}	V _{SS}	V _{SS}	V _{SS}	V _{SS}	V _{SS}	V _{SS}
—	68	V _{SS}	V _{SS}	V _{SS}	V _{SS}	V _{SS}	V _{SS}	V _{SS}	V _{SS}
61	69	P6 ₁	P6 ₁	P6 ₁	P6 ₁ / CS5	P6 ₁ / CS5	P6 ₁ / CS5	P6 ₁	NC
62	70	P6 ₂	P6 ₂	P6 ₂	P6 ₂	P6 ₂	P6 ₂	P6 ₂	NC
63	71	P6 ₃	P6 ₃	P6 ₃	P6 ₃	P6 ₃	P6 ₃	P6 ₃	NC
64	72	P2 ₇ / TIOCB5/ TMO1	P2 ₇ / TIOCB5/ TMO1	P2 ₇ / TIOCB5/ TMO1	P2 ₇ / TIOCB5/ TMO1	P2 ₇ / TIOCB5/ TMO1	P2 ₇ / TIOCB5/ TMO1	P2 ₇ / TIOCB5/ TMO1	NC
65	73	P2 ₆ / TIOCA5/ TMO0	P2 ₆ / TIOCA5/ TMO0	P2 ₆ / TIOCA5/ TMO0	P2 ₆ / TIOCA5/ TMO0	P2 ₆ / TIOCA5/ TMO0	P2 ₆ / TIOCA5/ TMO0	P2 ₆ / TIOCA5/ TMO0	NC
66	74	P2 ₅ / TIOCB4/ TMCI1	P2 ₅ / TIOCB4/ TMCI1	P2 ₅ / TIOCB4/ TMCI1	P2 ₅ / TIOCB4/ TMCI	P2 ₅ / TIOCB4/ TMCI1	P2 ₅ / TIOCB4/ TMCI1	P2 ₅ / TIOCB4/ TMCI1	NC
67	75	P2 ₄ / TIOCA4/ TMRI1	P2 ₄ / TIOCA4/ TMRI1	P2 ₄ / TIOCA4/ TMRI1	P2 ₄ / TIOCA4/ TMRI1	P2 ₄ / TIOCA4/ TMRI1	P2 ₄ / TIOCA4/ TMRI1	P2 ₄ / TIOCA4/ TMRI1	NC
68	76	P2 ₃ / TIOCD3/ TMCI0	P2 ₃ / TIOCD3/ TMCI0	P2 ₃ / TIOCD3/ TMCI0	P2 ₃ / TIOCD3/ TMCI0	P2 ₃ / TIOCD3/ TMCI0	P2 ₃ / TIOCD3/ TMCI0	P2 ₃ / TIOCD3/ TMCI0	NC
69	77	P2 ₂ / TIOCC3/ TMRI1	P2 ₂ / TIOCC3/ TMRI1	P2 ₂ / TIOCC3/ TMRI1	P2 ₂ / TIOCC3/ TMRI1	P2 ₂ / TIOCC3/ TMRI1	P2 ₂ / TIOCC3/ TMRI1	P2 ₂ / TIOCC3/ TMRI1	NC
70	78	P2 ₁ / TIOCB3	P2 ₁ / TIOCB3	P2 ₁ / TIOCB3	P2 ₁ / TIOCB3	P2 ₁ / TIOCB3	P2 ₁ / TIOCB3	P2 ₁ / TIOCB3	NC
71	79	P2 ₀ / TIOCA3	P2 ₀ / TIOCA3	P2 ₀ / TIOCA3	P2 ₀ / TIOCA3	P2 ₀ / TIOCA3	P2 ₀ / TIOCA3	P2 ₀ / TIOCA3	NC
72	80	WDTOVF	WDTOVF	WDTOVF	WDTOVF	WDTOVF	WDTOVF	WDTOVF	NC
73	81	RES	RES	RES	RES	RES	RES	RES	V _{PP}
74	82	NMI	NMI	NMI	NMI	NMI	NMI	NMI	A ₉

Pin No.		Pin Name								PROM*1
TFP-120	FP-128	Mode 1	Mode 2	Mode 3	Mode 4	Mode 5	Mode 6	Mode 7	Mode	
75	83	$\overline{\text{STBY}}$	$\overline{\text{STBY}}$	$\overline{\text{STBY}}$	$\overline{\text{STBY}}$	$\overline{\text{STBY}}$	$\overline{\text{STBY}}$	$\overline{\text{STBY}}$	V_{SS}	
76	84	V_{CC}	V_{CC}	V_{CC}	V_{CC}	V_{CC}	V_{CC}	V_{CC}	V_{CC}	
77	85	XTAL	XTAL	XTAL	XTAL	XTAL	XTAL	XTAL	NC	
78	86	EXTAL	EXTAL	EXTAL	EXTAL	EXTAL	EXTAL	EXTAL	NC	
79	87	V_{SS}	V_{SS}	V_{SS}	V_{SS}	V_{SS}	V_{SS}	V_{SS}	V_{SS}	
80	88	PF_7/\emptyset	PF_7/\emptyset	PF_7/\emptyset	PF_7/\emptyset	PF_7/\emptyset	PF_7/\emptyset	PF_7/\emptyset	NC	
81	89	V_{CC}	V_{CC}	V_{CC}	V_{CC}	V_{CC}	V_{CC}	V_{CC}	V_{CC}	
82	90	$\overline{\text{AS}}$	$\overline{\text{AS}}$	PF_6	$\overline{\text{AS}}$	$\overline{\text{AS}}$	$\overline{\text{AS}}$	PF_6	NC	
83	91	$\overline{\text{RD}}$	$\overline{\text{RD}}$	PF_5	$\overline{\text{RD}}$	$\overline{\text{RD}}$	$\overline{\text{RD}}$	PF_5	NC	
84	92	$\overline{\text{HWR}}$	$\overline{\text{HWR}}$	PF_4	$\overline{\text{HWR}}$	$\overline{\text{HWR}}$	$\overline{\text{HWR}}$	PF_4	NC	
85	93	$\overline{\text{LWR}}$	$\overline{\text{LWR}}$	PF_3	$\overline{\text{LWR}}$	$\overline{\text{LWR}}$	$\overline{\text{LWR}}$	PF_3	NC	
86	94	$\text{PF}_2/\overline{\text{WAIT}}$	$\text{PF}_2/\overline{\text{WAIT}}$	PF_2	$\text{PF}_2/\overline{\text{WAIT}}$	$\text{PF}_2/\overline{\text{WAIT}}$	$\text{PF}_2/\overline{\text{WAIT}}$	PF_2	$\overline{\text{CE}}$	
87	95	$\text{PF}_1/\overline{\text{BACK}}$	$\text{PF}_1/\overline{\text{BACK}}$	PF_1	$\text{PF}_1/\overline{\text{BACK}}$	$\text{PF}_1/\overline{\text{BACK}}$	$\text{PF}_1/\overline{\text{BACK}}$	PF_1	PGM	
88	96	$\text{PF}_0/\overline{\text{BREQ}}$	$\text{PF}_0/\overline{\text{BREQ}}$	PF_0	$\text{PF}_0/\overline{\text{BREQ}}$	$\text{PF}_0/\overline{\text{BREQ}}$	$\text{PF}_0/\overline{\text{BREQ}}$	PF_0	NC	
89	97	$\text{P5}_0/\text{TxD2}$	$\text{P5}_0/\text{TxD2}$	$\text{P5}_0/\text{TxD2}$	$\text{P5}_0/\text{TxD2}$	$\text{P5}_0/\text{TxD2}$	$\text{P5}_0/\text{TxD2}$	$\text{P5}_0/\text{TxD2}$	NC	
90	98	$\text{P5}_1/\text{RxD2}$	$\text{P5}_1/\text{RxD2}$	$\text{P5}_1/\text{RxD2}$	$\text{P5}_1/\text{RxD2}$	$\text{P5}_1/\text{RxD2}$	$\text{P5}_1/\text{RxD2}$	$\text{P5}_1/\text{RxD2}$	NC	
—	99	V_{SS}	V_{SS}	V_{SS}	V_{SS}	V_{SS}	V_{SS}	V_{SS}	V_{SS}	
—	100	V_{SS}	V_{SS}	V_{SS}	V_{SS}	V_{SS}	V_{SS}	V_{SS}	V_{SS}	
91	101	$\text{P5}_2/\text{SCK2}$	$\text{P5}_2/\text{SCK2}$	$\text{P5}_2/\text{SCK2}$	$\text{P5}_2/\text{SCK2}$	$\text{P5}_2/\text{SCK2}$	$\text{P5}_2/\text{SCK2}$	$\text{P5}_2/\text{SCK2}$	NC	
92	102	$\text{P5}_3/\overline{\text{ADTRG}}$	$\text{P5}_3/\overline{\text{ADTRG}}$	$\text{P5}_3/\overline{\text{ADTRG}}$	$\text{P5}_3/\overline{\text{ADTRG}}$	$\text{P5}_3/\overline{\text{ADTRG}}$	$\text{P5}_3/\overline{\text{ADTRG}}$	$\text{P5}_3/\overline{\text{ADTRG}}$	NC	
93	103	AV_{CC}	AV_{CC}	AV_{CC}	AV_{CC}	AV_{CC}	AV_{CC}	AV_{CC}	V_{CC}	
94	104	V_{ref}	V_{ref}	V_{ref}	V_{ref}	V_{ref}	V_{ref}	V_{ref}	V_{CC}	
95	105	$\text{P4}_0/\text{AN0}$	$\text{P4}_0/\text{AN0}$	$\text{P4}_0/\text{AN0}$	$\text{P4}_0/\text{AN0}$	$\text{P4}_0/\text{AN0}$	$\text{P4}_0/\text{AN0}$	$\text{P4}_0/\text{AN0}$	NC	
96	106	$\text{P4}_1/\text{AN1}$	$\text{P4}_1/\text{AN1}$	$\text{P4}_1/\text{AN1}$	$\text{P4}_1/\text{AN1}$	$\text{P4}_1/\text{AN1}$	$\text{P4}_1/\text{AN1}$	$\text{P4}_1/\text{AN1}$	NC	
97	107	$\text{P4}_2/\text{AN2}$	$\text{P4}_2/\text{AN2}$	$\text{P4}_2/\text{AN2}$	$\text{P4}_2/\text{AN2}$	$\text{P4}_2/\text{AN2}$	$\text{P4}_2/\text{AN2}$	$\text{P4}_2/\text{AN2}$	NC	
98	108	$\text{P4}_3/\text{AN3}$	$\text{P4}_3/\text{AN3}$	$\text{P4}_3/\text{AN3}$	$\text{P4}_3/\text{AN3}$	$\text{P4}_3/\text{AN3}$	$\text{P4}_3/\text{AN3}$	$\text{P4}_3/\text{AN3}$	NC	
99	109	$\text{P4}_4/\text{AN4}$	$\text{P4}_4/\text{AN4}$	$\text{P4}_4/\text{AN4}$	$\text{P4}_4/\text{AN4}$	$\text{P4}_4/\text{AN4}$	$\text{P4}_4/\text{AN4}$	$\text{P4}_4/\text{AN4}$	NC	
100	110	$\text{P4}_5/\text{AN5}$	$\text{P4}_5/\text{AN5}$	$\text{P4}_5/\text{AN5}$	$\text{P4}_5/\text{AN5}$	$\text{P4}_5/\text{AN5}$	$\text{P4}_5/\text{AN5}$	$\text{P4}_5/\text{AN5}$	NC	
101	111	$\text{P4}_6/\text{AN6}/\text{DA0}^{*2}$	$\text{P4}_6/\text{AN6}/\text{DA0}^{*2}$	$\text{P4}_6/\text{AN6}/\text{DA0}^{*2}$	$\text{P4}_6/\text{AN6}/\text{DA0}^{*2}$	$\text{P4}_6/\text{AN6}/\text{DA0}^{*2}$	$\text{P4}_6/\text{AN6}/\text{DA0}^{*2}$	$\text{P4}_6/\text{AN6}/\text{DA0}^{*2}$	NC	
102	112	$\text{P4}_7/\text{AN7}/\text{DA1}^{*2}$	$\text{P4}_7/\text{AN7}/\text{DA1}^{*2}$	$\text{P4}_7/\text{AN7}/\text{DA1}^{*2}$	$\text{P4}_7/\text{AN7}/\text{DA1}^{*2}$	$\text{P4}_7/\text{AN7}/\text{DA1}^{*2}$	$\text{P4}_7/\text{AN7}/\text{DA1}^{*2}$	$\text{P4}_7/\text{AN7}/\text{DA1}^{*2}$	NC	
103	113	AV_{SS}	AV_{SS}	AV_{SS}	AV_{SS}	AV_{SS}	AV_{SS}	AV_{SS}	V_{SS}	

Pin No.		Pin Name							PROM*1
TFP-120	FP-128	Mode 1	Mode 2	Mode 3	Mode 4	Mode 5	Mode 6	Mode 7	Mode
104	114	V _{SS}	V _{SS}	V _{SS}	V _{SS}	V _{SS}	V _{SS}	V _{SS}	V _{SS}
105	115	P1 ₇ / TIOCB2/ TCLKD	P1 ₇ / TIOCB2/ TCLKD	P1 ₇ / TIOCB2/ TCLKD	P1 ₇ / TIOCB2/ TCLKD	P1 ₇ / TIOCB2/ TCLKD	P1 ₇ / TIOCB2/ TCLKD	P1 ₇ / TIOCB2/ TCLKD	NC
106	116	P1 ₆ / TIOCA2	P1 ₆ / TIOCA2	P1 ₆ / TIOCA2	P1 ₆ / TIOCA2	P1 ₆ / TIOCA2	P1 ₆ / TIOCA2	P1 ₆ / TIOCA2	NC
107	117	P1 ₅ / TIOCB1/ TCLKC	P1 ₅ / TIOCB1/ TCLKC	P1 ₅ / TIOCB1/ TCLKC	P1 ₅ / TIOCB1/ TCLKC	P1 ₅ / TIOCB1/ TCLKC	P1 ₅ / TIOCB1/ TCLKC	P1 ₅ / TIOCB1/ TCLKC	NC
108	118	P1 ₄ / TIOCA1	P1 ₄ / TIOCA1	P1 ₄ / TIOCA1	P1 ₄ / TIOCA1	P1 ₄ / TIOCA1	P1 ₄ / TIOCA1	P1 ₄ / TIOCA1	NC
109	119	P1 ₃ / TIOCD0/ TCLKB	P1 ₃ / TIOCD0/ TCLKB	P1 ₃ / TIOCD0/ TCLKB	P1 ₃ / TIOCD0/ TCLKB	P1 ₃ / TIOCD0/ TCLKB	P1 ₃ / TIOCD0/ TCLKB	P1 ₃ / TIOCD0/ TCLKB	NC
110	120	P1 ₂ / TIOCC0/ TCLKA	P1 ₂ / TIOCC0/ TCLKA	P1 ₂ / TIOCC0/ TCLKA	P1 ₂ / TIOCC0/ TCLKA	P1 ₂ / TIOCC0/ TCLKA	P1 ₂ / TIOCC0/ TCLKA	P1 ₂ / TIOCC0/ TCLKA	NC
111	121	P1 ₁ / TIOCB0	P1 ₁ / TIOCB0	P1 ₁ / TIOCB0	P1 ₁ / TIOCB0	P1 ₁ / TIOCB0	P1 ₁ / TIOCB0	P1 ₁ / TIOCB0	NC
112	122	P1 ₀ / TIOCA0	P1 ₀ / TIOCA0	P1 ₀ / TIOCA0	P1 ₀ / TIOCA0	P1 ₀ / TIOCA0	P1 ₀ / TIOCA0	P1 ₀ / TIOCA0	NC
113	123	MD ₀	MD ₀	MD ₀	MD ₀	MD ₀	MD ₀	MD ₀	V _{SS}
114	124	MD ₁	MD ₁	MD ₁	MD ₁	MD ₁	MD ₁	MD ₁	V _{SS}
115	125	MD ₂	MD ₂	MD ₂	MD ₂	MD ₂	MD ₂	MD ₂	V _{SS}
116	126	PG ₀	PG ₀	PG ₀	PG ₀	PG ₀	PG ₀	PG ₀	NC
117	127	PG ₁	PG ₁	PG ₁	PG ₁ / $\overline{\text{CS3}}$	PG ₁ / $\overline{\text{CS3}}$	PG ₁ / $\overline{\text{CS3}}$	PG ₁	NC
118	128	PG ₂	PG ₂	PG ₂	PG ₂ / $\overline{\text{CS2}}$	PG ₂ / $\overline{\text{CS2}}$	PG ₂ / $\overline{\text{CS2}}$	PG ₂	NC
119	1	PG ₃	PG ₃	PG ₃	PG ₃ / $\overline{\text{CS1}}$	PG ₃ / $\overline{\text{CS1}}$	PG ₃ / $\overline{\text{CS1}}$	PG ₃	NC
120	2	PG ₄ / $\overline{\text{CS0}}$	PG ₄ / $\overline{\text{CS0}}$	PG ₄	PG ₄ / $\overline{\text{CS0}}$	PG ₄ / $\overline{\text{CS0}}$	PG ₄ / $\overline{\text{CS0}}$	PG ₄	NC
—	3	V _{SS}	V _{SS}	V _{SS}	V _{SS}	V _{SS}	V _{SS}	V _{SS}	V _{SS}
—	4	NC	NC	NC	NC	NC	NC	NC	NC

Notes: NC pins should be connected to V_{SS} or left open.

1. There is no PROM version of the H8S/2393.
2. As the H8S/2393 does not support a D/A converter, it does not have the DA0 and DA1 outputs.

1.3.3 Pin Functions

Table 1-3 outlines the pin functions of the H8S/2355 Series.

Table 1-3 Pin Functions

Type	Symbol	Pin No.		I/O	Name and Function
		TFP-120	FP-128		
Power	V_{CC}	1, 33, 52, 76, 81	5, 39, 58, 84, 89	Input	Power supply: For connection to the power supply. All V_{CC} pins should be connected to the system power supply.
	V_{SS}	6, 15, 24, 38, 47, 59, 79, 104	3, 10, 19, 28, 35, 36, 44, 53, 65, 67, 68, 87, 99, 100, 114	Input	Ground: For connection to ground (0 V). All V_{SS} pins should be connected to the system power supply (0 V).
Clock	XTAL	77	85	Input	Connects to a crystal oscillator. See section 18, Clock Pulse Generator, for typical connection diagrams for a crystal oscillator and external clock input.
	EXTAL	78	86	Input	Connects to a crystal oscillator. The EXTAL pin can also input an external clock. See section 18, Clock Pulse Generator, for typical connection diagrams for a crystal oscillator and external clock input.
	∅	80	88	Output	System clock: Supplies the system clock to an external device.

Type	Symbol	Pin No.		I/O	Name and Function																												
		TFP-120	FP-128																														
Operating mode control	MD ₂ to MD ₀	115 to 113	125 to 123	Input	<p>Mode pins: These pins set the operating mode.</p> <p>The relation between the settings of pins MD₂ to MD₀ and the operating mode is shown below. These pins should not be changed while the H8S/2355 Series is operating.</p> <table border="1"> <thead> <tr> <th>MD₂</th> <th>MD₁</th> <th>MD₀</th> <th>Operating Mode</th> </tr> </thead> <tbody> <tr> <td rowspan="3">0</td> <td rowspan="2">0</td> <td>0</td> <td>—</td> </tr> <tr> <td>1</td> <td>Mode 1</td> </tr> <tr> <td>1</td> <td>0</td> <td>Mode 2</td> </tr> <tr> <td rowspan="2">1</td> <td rowspan="2">0</td> <td>1</td> <td>Mode 3</td> </tr> <tr> <td>0</td> <td>Mode 4</td> </tr> <tr> <td rowspan="3">1</td> <td rowspan="2">1</td> <td>0</td> <td>Mode 5</td> </tr> <tr> <td>1</td> <td>Mode 6</td> </tr> <tr> <td>1</td> <td>1</td> <td>Mode 7</td> </tr> </tbody> </table>	MD ₂	MD ₁	MD ₀	Operating Mode	0	0	0	—	1	Mode 1	1	0	Mode 2	1	0	1	Mode 3	0	Mode 4	1	1	0	Mode 5	1	Mode 6	1	1	Mode 7
		MD ₂	MD ₁			MD ₀	Operating Mode																										
0	0	0	—																														
		1	Mode 1																														
	1	0	Mode 2																														
1	0	1	Mode 3																														
		0	Mode 4																														
1	1	0	Mode 5																														
		1	Mode 6																														
	1	1	Mode 7																														
System control	$\overline{\text{RES}}$	73	81	Input	Reset input: When this pin is driven low, the chip is reset. The type of reset can be selected according to the NMI input level. At power-on, the NMI pin input level should be set high.																												
	$\overline{\text{STBY}}$	75	83	Input	Standby: When this pin is driven low, a transition is made to hardware standby mode.																												
	$\overline{\text{BREQ}}$	88	96	Input	Bus request: Used by an external bus master to issue a bus request to the H8S/2355 Series.																												
	$\overline{\text{BACK}}$	87	95	Output	Bus request acknowledge: Indicates that the bus has been released to an external bus master.																												

Type	Symbol	Pin No.		I/O	Name and Function
		TFP-120	FP-128		
Interrupts	NMI	74	82	Input	Nonmaskable interrupt: Requests a nonmaskable interrupt. When this pin is not used, it should be fixed high.
	$\overline{\text{IRQ7}}$ to $\overline{\text{IRQ0}}$	28 to 25, 29 to 32	32 to 29, 33, 34, 37, 38	Input	Interrupt request 7 to 0: These pins request a maskable interrupt.
Address bus	A_{23} to A_0	28 to 25, 23 to 16, 14 to 7, 5 to 2	32 to 29, 27 to 20, 18 to 11, 9 to 6	Output	Address bus: These pins output an address.
Data bus	D_{15} to D_0	51 to 48, 46 to 39, 37 to 34	57 to 54, 52 to 45, 43 to 40	I/O	Data bus: These pins constitute a bidirectional data bus.
Bus control	$\overline{\text{CS7}}$ to $\overline{\text{CS0}}$	29, 30, 61, 60, 117 to 120	33, 34, 69, 66, 127, 128, 1, 2	Output	Chip select: Signals for selecting areas 7 to 0.
	$\overline{\text{AS}}$	82	90	Output	Address strobe: When this pin is low, it indicates that address output on the address bus is enabled.
	$\overline{\text{RD}}$	83	91	Output	Read: When this pin is low, it indicates that the external address space can be read.
	$\overline{\text{HWR}}$	84	92	Output	High write: A strobe signal that writes to external space and indicates that the upper half (D_{15} to D_8) of the data bus is enabled.
	$\overline{\text{LWR}}$	85	93	Output	Low write: A strobe signal that writes to external space and indicates that the lower half (D_7 to D_0) of the data bus is enabled.
	$\overline{\text{WAIT}}$	86	94	Input	Wait: Requests insertion of a wait state in the bus cycle when accessing external 3-state address space.
	$\overline{\text{LCAS}}$	86	94	Output	Lower column address strobe: The 2-CAS type (LCASS = 0) DRAM lower column address strobe signal

Type	Symbol	Pin No.			Name and Function
		TFP-120	FP-128	I/O	
16-bit timer-pulse unit (TPU)	TCLKD to TCLKA	105, 107, 109, 110	115, 117, 119, 120	Input	Clock input D to A: These pins input an external clock.
	TIOCA0, TIOCB0, TIOCC0, TIOCD0	112 to 109	122 to 119	I/O	Input capture/ output compare match A0 to D0: The TGR0A to TGR0D input capture input or output compare output, or PWM output pins.
	TIOCA1, TIOCB1	108, 107	118, 117	I/O	Input capture/ output compare match A1 and B1: The TGR1A and TGR1B input capture input or output compare output, or PWM output pins.
	TIOCA2, TIOCB2	106, 105	116, 115	I/O	Input capture/ output compare match A2 and B2: The TGR2A and TGR2B input capture input or output compare output, or PWM output pins.
	TIOCA3, TIOCB3, TIOCC3, TIOCD3	71 to 68	79 to 76	I/O	Input capture/ output compare match A3 to D3: The TGR3A to TGR3D input capture input or output compare output, or PWM output pins.
	TIOCA4, TIOCB4	67, 66	75, 74	I/O	Input capture/ output compare match A4 and B4: The TGR4A and TGR4B input capture input or output compare output, or PWM output pins.
	TIOCA5, TIOCB5	65, 64	73, 72	I/O	Input capture/ output compare match A5 and B5: The TGR5A and TGR5B input capture input or output compare output, or PWM output pins.
8-bit timer	TMO0, TMO1	65, 64	73, 72	Output	Compare match output: The compare match output pins.
	TMCI0, TMCI1	68, 66	76, 74	Input	Counter external clock input: Input pins for the external clock input to the counter.
	TMRI0, TMRI1	69, 67	77, 75	Input	Counter external reset input: The counter reset input pins.
Watchdog timer (WDT)	WDTOV \bar{F}	72	80	Output	Watchdog timer overflows: The counter overflows signal output pin in watchdog timer mode.

Type	Symbol	Pin No.			Name and Function
		TFP-120	FP-128	I/O	
Serial communication interface (SCI)	TxD2, TxD1, TxD0	89, 54, 53	97, 60, 59	Output	Transmit data (channel 0, 1, 2): Data output pins.
	Smart Card interface	RxD2, RxD1, RxD0	90, 56, 55	98, 62, 61	Input
SCK2, SCK1 SCK0		91, 58 57	101, 64, 63	I/O	Serial clock (channel 0, 1, 2): Clock I/O pins.
A/D converter		AN7 to AN0	102 to 95	112 to 105	Input
	ADTRG	92	102	Input	A/D conversion external trigger input: Pin for input of an external trigger to start A/D conversion.
D/A converter*	DA1, DA0	102, 101	112, 111	Output	Analog output: D/A converter analog output pins.
A/D converter and D/A converters	AV _{cc}	93	103	Input	This is the power supply pin for the A/D converter and D/A converter. When the A/D converter and D/A converter are not used, this pin should be connected to the system power supply (+5 V).
	AV _{ss}	103	113	Input	This is the ground pin for the A/D converter and D/A converter. This pin should be connected to the system power supply (0 V).
	V _{ref}	94	104	Input	This is the reference voltage input pin for the A/D converter and D/A converter. When the A/D converter and D/A converter are not used, this pin should be connected to the system power supply (+5 V).

Type	Symbol	Pin No.		I/O	Name and Function
		TFP-120	FP-128		
I/O ports	P1 ₇ to P1 ₀	105 to 112	115 to 122	I/O	Port 1: An 8-bit I/O port. Input or output can be designated for each bit by means of the port 1 data direction register (P1DDR).
	P2 ₇ to P2 ₀	64 to 71	72 to 79	I/O	Port 2: An 8-bit I/O port. Input or output can be designated for each bit by means of the port 2 data direction register (P2DDR).
	P3 ₅ to P3 ₀	58 to 53	64 to 59	I/O	Port 3: A 6-bit I/O port. Input or output can be designated for each bit by means of the port 3 data direction register (P3DDR).
	P4 ₇ to P4 ₀	102 to 95	112 to 105	Input	Port 4: An 8-bit input port.
	P5 ₃ to P5 ₀	92 to 89	102, 101, 98, 97	I/O	Port 5: A 4-bit I/O port. Input or output can be designated for each bit by means of the port 5 data direction register (P5DDR).
	P6 ₇ to P6 ₀	29 to 32, 63 to 60	33, 34, 37, 38, 71 to 69, 66	I/O	Port 6: An 8-bit I/O port. Input or output can be designated for each bit by means of the port 6 data direction register (P6DDR).
	PA ₇ to PA ₀	28 to 25, 23 to 20	32 to 29, 27 to 24	I/O	Port A: An 8-bit I/O port. Input or output can be designated for each bit by means of the port A data direction register (PADDDR).
	PB ₇ to PB ₀	19 to 16, 14 to 11	23 to 20, 18 to 15	I/O	Port B: An 8-bit I/O port. Input or output can be designated for each bit by means of the port B data direction register (PBDDR).
	PC ₇ to PC ₀	10 to 7, 5 to 2	14 to 11, 9 to 6	I/O	Port C: An 8-bit I/O port. Input or output can be designated for each bit by means of the port C data direction register (PCDDR).

Type	Symbol	Pin No.			Name and Function
		TFP-120	FP-128	I/O	
I/O ports	PD ₇ to PD ₀	51 to 48, 46 to 43	57 to 54, 52 to 49	I/O	Port D: An 8-bit I/O port. Input or output can be designated for each bit by means of the port D data direction register (PDDDR).
	PE ₇ to PE ₀	42 to 39, 37 to 34	48 to 45, 43 to 40	I/O	Port E: An 8-bit I/O port. Input or output can be designated for each bit by means of the port E data direction register (PEDDR).
	PF ₇ to PF ₀	80, 82 to 88	88, 90 to 96	I/O	Port F: An 8-bit I/O port. Input or output can be designated for each bit by means of the port F data direction register (PFDDR).
	PG ₄ to PG ₀	120 to 116	2, 1, 128 to 126	I/O	Port G: A 5-bit I/O port. Input or output can be designated for each bit by means of the port G data direction register (PGDDR).

Note: * The H8S/2393 does not support a D/A converter.

2.1 Overview

The H8S/2000 CPU is a high-speed central processing unit with an internal 32-bit architecture that is upward-compatible with the H8/300 and H8/300H CPUs. The H8S/2000 CPU has sixteen 16-bit general registers, can address a 16-Mbyte (architecturally 4-Gbyte) linear address space, and is ideal for realtime control.

2.1.1 Features

The H8S/2000 CPU has the following features.

- Upward-compatible with H8/300 and H8/300H CPUs
 - Can execute H8/300 and H8/300H object programs
- General-register architecture
 - Sixteen 16-bit general registers (also usable as sixteen 8-bit registers or eight 32-bit registers)
- Sixty-five basic instructions
 - 8/16/32-bit arithmetic and logic instructions
 - Multiply and divide instructions
 - Powerful bit-manipulation instructions
- Eight addressing modes
 - Register direct [Rn]
 - Register indirect [@ERn]
 - Register indirect with displacement [@(d:16,ERn) or @(d:32,ERn)]
 - Register indirect with post-increment or pre-decrement [@ERn+ or @-ERn]
 - Absolute address [@aa:8, @aa:16, @aa:24, or @aa:32]
 - Immediate [#xx:8, #xx:16, or #xx:32]
 - Program-counter relative [@(d:8,PC) or @(d:16,PC)]
 - Memory indirect [@@aa:8]
- 16-Mbyte address space
 - Program: 16 Mbytes
 - Data: 16 Mbytes (4 Gbytes architecturally)

- High-speed operation
 - All frequently-used instructions execute in one or two states
 - Maximum clock rate : 20 MHz
 - 8/16/32-bit register-register add/subtract : 50 ns
 - 8×8 -bit register-register multiply : 600 ns
 - $16 \div 8$ -bit register-register divide : 600 ns
 - 16×16 -bit register-register multiply : 1000 ns
 - $32 \div 16$ -bit register-register divide : 1000 ns
- Two CPU operating modes
 - Normal mode
 - Advanced mode
- Power-down state
 - Transition to power-down state by SLEEP instruction
 - CPU clock speed selection

2.1.2 Differences between H8S/2600 CPU and H8S/2000 CPU

The differences between the H8S/2600 CPU and the H8S/2000 CPU are as shown below.

- Register configuration

The MAC register is supported only by the H8S/2600 CPU.
- Basic instructions

The four instructions MAC, CLRMAC, LDMAC, and STMAC are supported only by the H8S/2600 CPU.
- Number of execution states

The number of execution states of the MULXU and MULXS instructions.

Instruction	Mnemonic	Internal Operation	
		H8S/2600	H8S/2000
MULXU	MULXU.B Rs, Rd	3	12
	MULXU.W Rs, ERd	4	20
MULXS	MULXS.B Rs, Rd	4	13
	MULXS.W Rs, ERd	5	21

There are also differences in the address space, CCR and EXR register functions, power-down state, etc., depending on the product.

2.1.3 Differences from H8/300 CPU

In comparison to the H8/300 CPU, the H8S/2000 CPU has the following enhancements.

- More general registers and control registers
 - Eight 16-bit expanded registers, and one 8-bit control register, have been added.
- Expanded address space
 - Normal mode supports the same 64-kbyte address space as the H8/300 CPU.
 - Advanced mode supports a maximum 16-Mbyte address space.
- Enhanced addressing
 - The addressing modes have been enhanced to make effective use of the 16-Mbyte address space.
- Enhanced instructions
 - Addressing modes of bit-manipulation instructions have been enhanced.
 - Signed multiply and divide instructions have been added.
 - Two-bit shift instructions have been added.
 - Instructions for saving and restoring multiple registers have been added.
 - A test and set instruction has been added.
- Higher speed
 - Basic instructions execute twice as fast.

2.1.4 Differences from H8/300H CPU

In comparison to the H8/300H CPU, the H8S/2000 CPU has the following enhancements.

- Additional control register
 - One 8-bit control register has been added.
- Enhanced instructions
 - Addressing modes of bit-manipulation instructions have been enhanced.
 - Two-bit shift instructions have been added.
 - Instructions for saving and restoring multiple registers have been added.
 - A test and set instruction has been added.
- Higher speed
 - Basic instructions execute twice as fast.

2.2 CPU Operating Modes

The H8S/2000 CPU has two operating modes: normal and advanced. Normal mode supports a maximum 64-kbyte address space. Advanced mode supports a maximum 16-Mbyte total address space (architecturally a maximum 16-Mbyte program area and a maximum of 4 Gbytes for program and data areas combined). The mode is selected by the mode pins of the microcontroller.

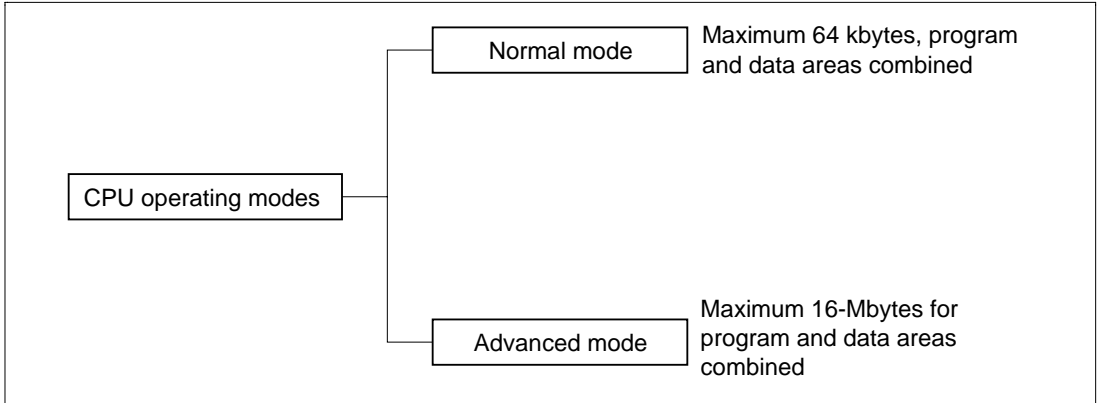

Figure 2-1 CPU Operating Modes

(1) Normal Mode

The exception vector table and stack have the same structure as in the H8/300 CPU.

Address Space: A maximum address space of 64 kbytes can be accessed.

Extended Registers (En): The extended registers (E0 to E7) can be used as 16-bit registers, or as the upper 16-bit segments of 32-bit registers. When En is used as a 16-bit register it can contain any value, even when the corresponding general register (Rn) is used as an address register. If the general register is referenced in the register indirect addressing mode with pre-decrement (@-Rn) or post-increment (@Rn+) and a carry or borrow occurs, however, the value in the corresponding extended register (En) will be affected.

Instruction Set: All instructions and addressing modes can be used. Only the lower 16 bits of effective addresses (EA) are valid.

Exception Vector Table and Memory Indirect Branch Addresses: In normal mode the top area starting at H'0000 is allocated to the exception vector table. One branch address is stored per 16 bits. The configuration of the exception vector table in normal mode is shown in figure 2-2. For details of the exception vector table, see section 4, Exception Handling.

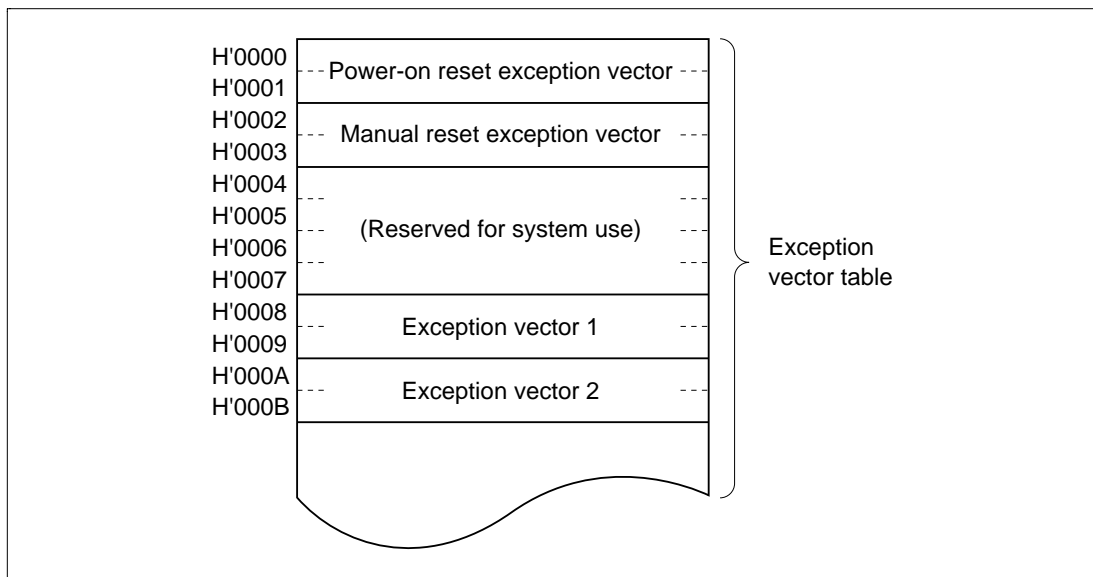

Figure 2-2 Exception Vector Table (Normal Mode)

The memory indirect addressing mode (@@aa:8) employed in the JMP and JSR instructions uses an 8-bit absolute address included in the instruction code to specify a memory operand that contains a branch address. In normal mode the operand is a 16-bit word operand, providing a 16-bit branch address. Branch addresses can be stored in the top area from H'0000 to H'00FF. Note that this area is also used for the exception vector table.

Stack Structure: When the program counter (PC) is pushed onto the stack in a subroutine call, and the PC, condition-code register (CCR), and extended control register (EXR) are pushed onto the stack in exception handling, they are stored as shown in figure 2-3. When EXR is invalid, it is not pushed onto the stack. For details, see section 4, Exception Handling.

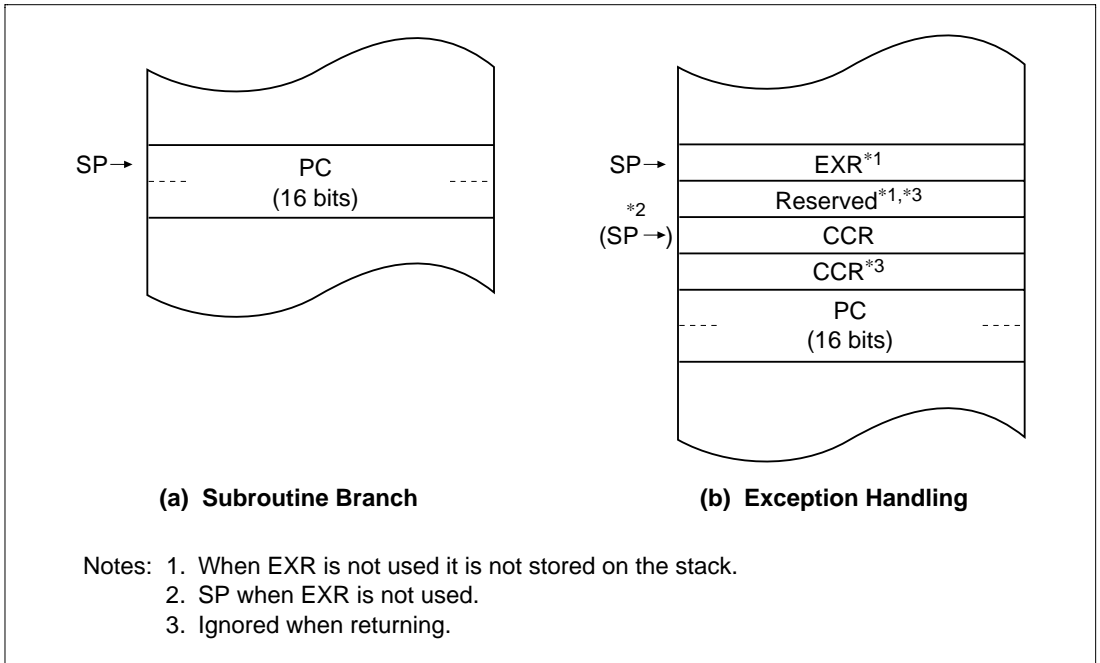

Figure 2-3 Stack Structure in Normal Mode

(2) Advanced Mode

Address Space: Linear access is provided to a 16-Mbyte maximum address space (architecturally a maximum 16-Mbyte program area and a maximum 4-Gbyte data area, with a maximum of 4 Gbytes for program and data areas combined).

Extended Registers (En): The extended registers (E0 to E7) can be used as 16-bit registers, or as the upper 16-bit segments of 32-bit registers or address registers.

Instruction Set: All instructions and addressing modes can be used.

Exception Vector Table and Memory Indirect Branch Addresses: In advanced mode the top area starting at H'00000000 is allocated to the exception vector table in units of 32 bits. In each 32 bits, the upper 8 bits are ignored and a branch address is stored in the lower 24 bits (figure 2-4). For details of the exception vector table, see section 4, Exception Handling.

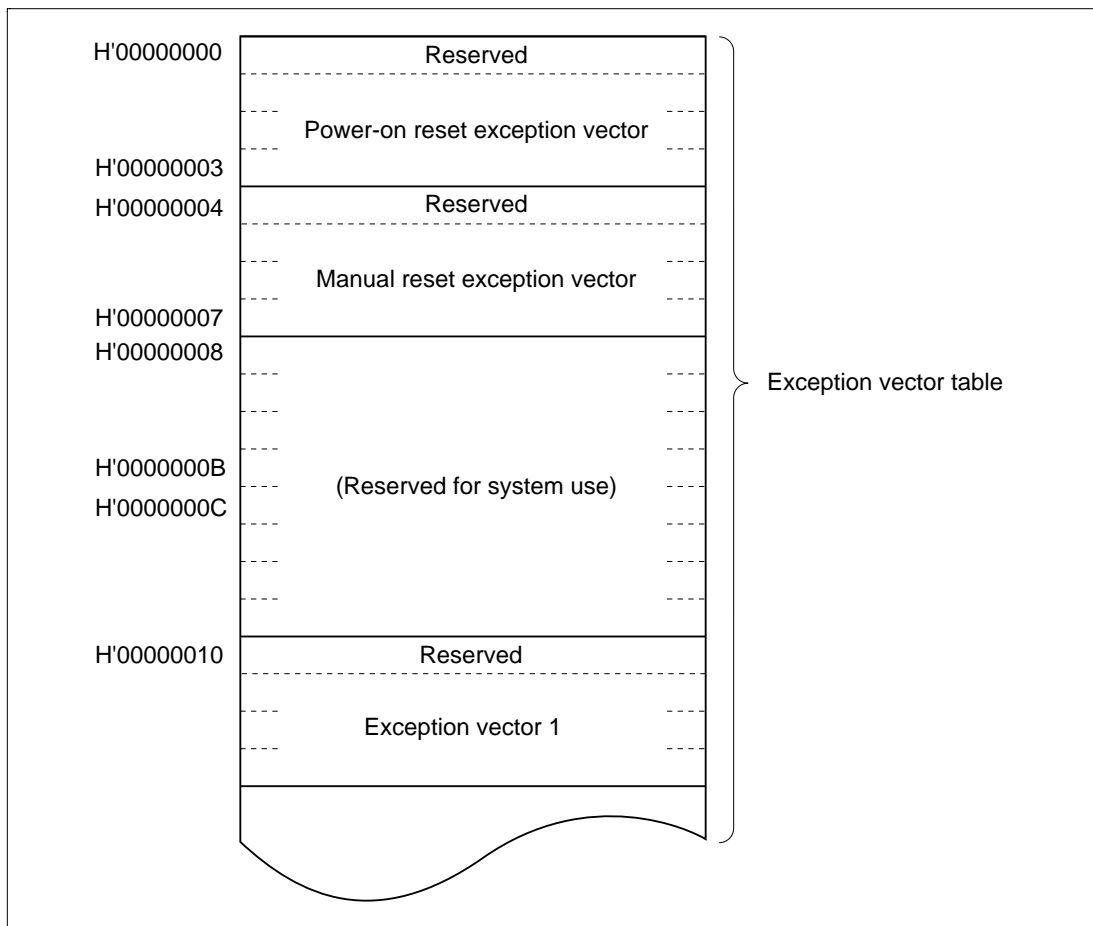

Figure 2-4 Exception Vector Table (Advanced Mode)

The memory indirect addressing mode (@@aa:8) employed in the JMP and JSR instructions uses an 8-bit absolute address included in the instruction code to specify a memory operand that contains a branch address. In advanced mode the operand is a 32-bit longword operand, providing a 32-bit branch address. The upper 8 bits of these 32 bits are a reserved area that is regarded as H'00. Branch addresses can be stored in the area from H'00000000 to H'000000FF. Note that the first part of this range is also the exception vector table.

Stack Structure: In advanced mode, when the program counter (PC) is pushed onto the stack in a subroutine call, and the PC, condition-code register (CCR), and extended control register (EXR) are pushed onto the stack in exception handling, they are stored as shown in figure 2-5. When EXR is invalid, it is not pushed onto the stack. For details, see section 4, Exception Handling.

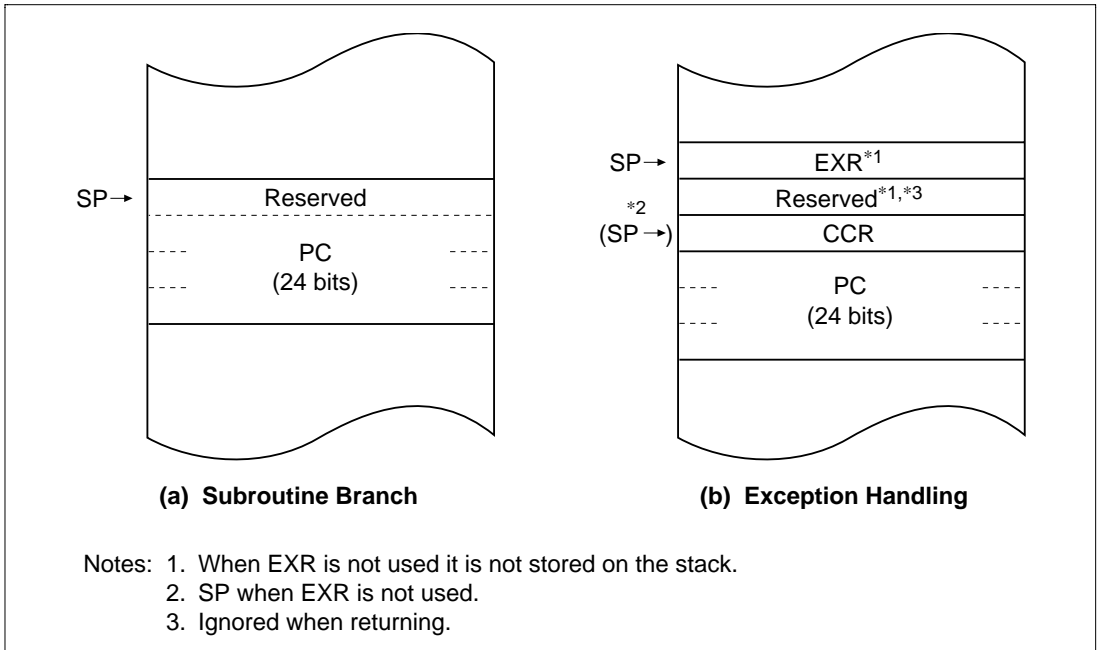

Figure 2-5 Stack Structure in Advanced Mode

2.3 Address Space

Figure 2-6 shows a memory map of the H8S/2000 CPU. The H8S/2000 CPU provides linear access to a maximum 64-kbyte address space in normal mode, and a maximum 16-Mbyte (architecturally 4-Gbyte) address space in advanced mode.

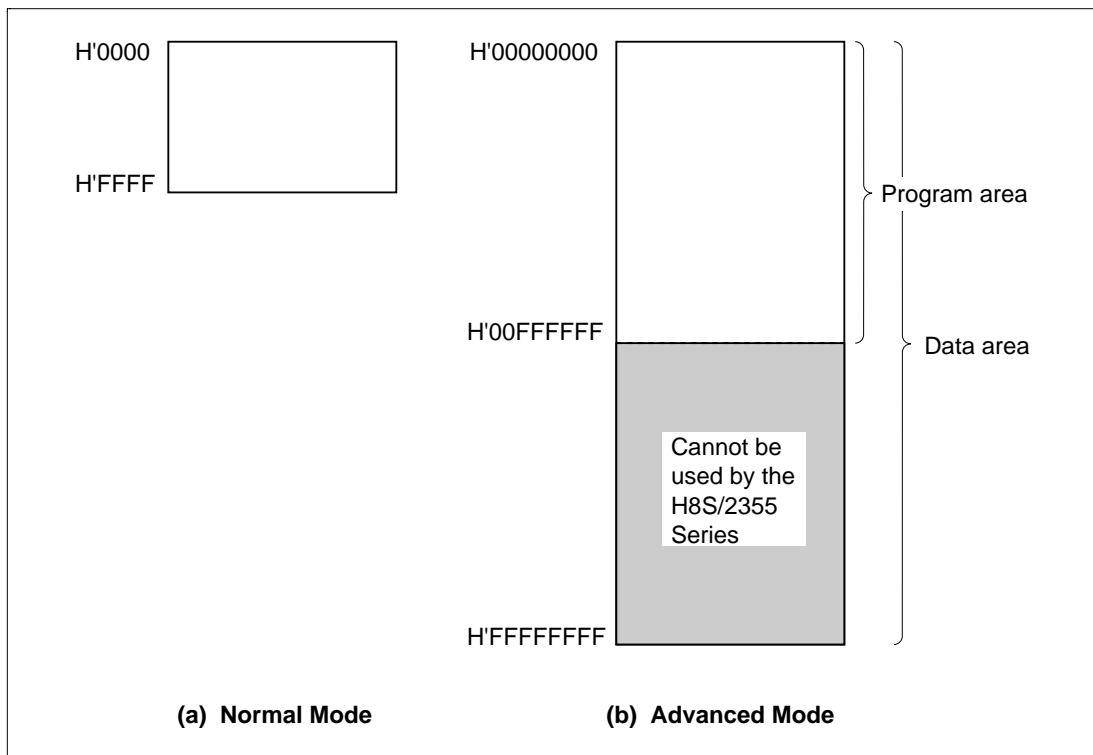

Figure 2-6 Memory Map

2.4 Register Configuration

2.4.1 Overview

The CPU has the internal registers shown in figure 2-7. There are two types of registers: general registers and control registers.

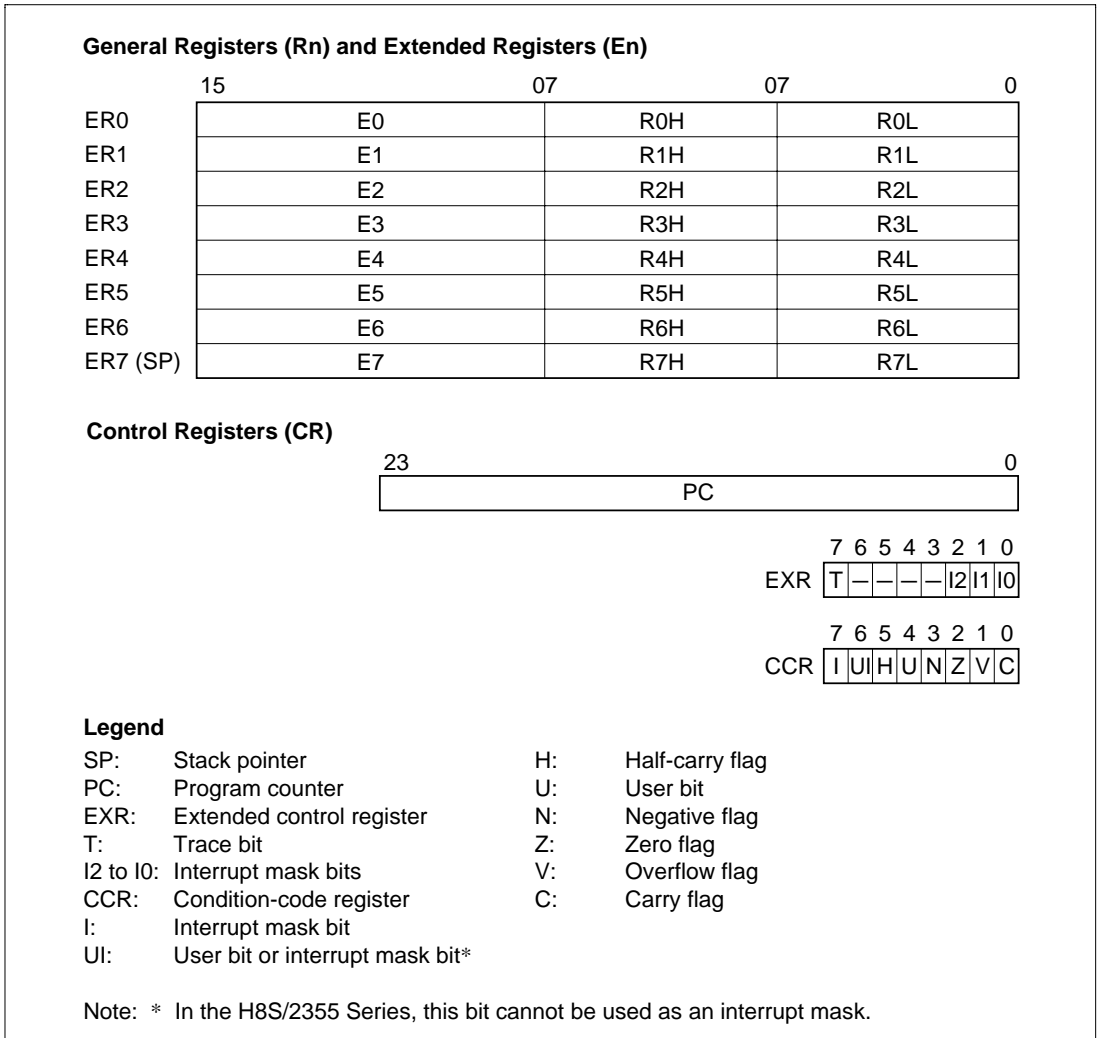

Figure 2-7 CPU Registers

2.4.2 General Registers

The CPU has eight 32-bit general registers. These general registers are all functionally alike and can be used as both address registers and data registers. When a general register is used as a data register, it can be accessed as a 32-bit, 16-bit, or 8-bit register. When the general registers are used as 32-bit registers or address registers, they are designated by the letters ER (ER0 to ER7).

The ER registers divide into 16-bit general registers designated by the letters E (E0 to E7) and R (R0 to R7). These registers are functionally equivalent, providing a maximum sixteen 16-bit registers. The E registers (E0 to E7) are also referred to as extended registers.

The R registers divide into 8-bit general registers designated by the letters RH (R0H to R7H) and RL (R0L to R7L). These registers are functionally equivalent, providing a maximum sixteen 8-bit registers.

Figure 2-8 illustrates the usage of the general registers. The usage of each register can be selected independently.

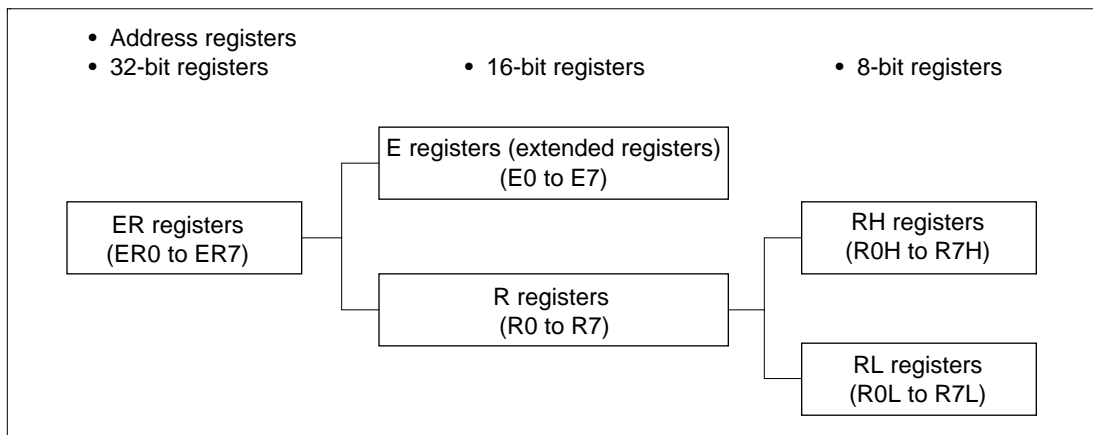

Figure 2-8 Usage of General Registers

General register ER7 has the function of stack pointer (SP) in addition to its general-register function, and is used implicitly in exception handling and subroutine calls. Figure 2-9 shows the stack.

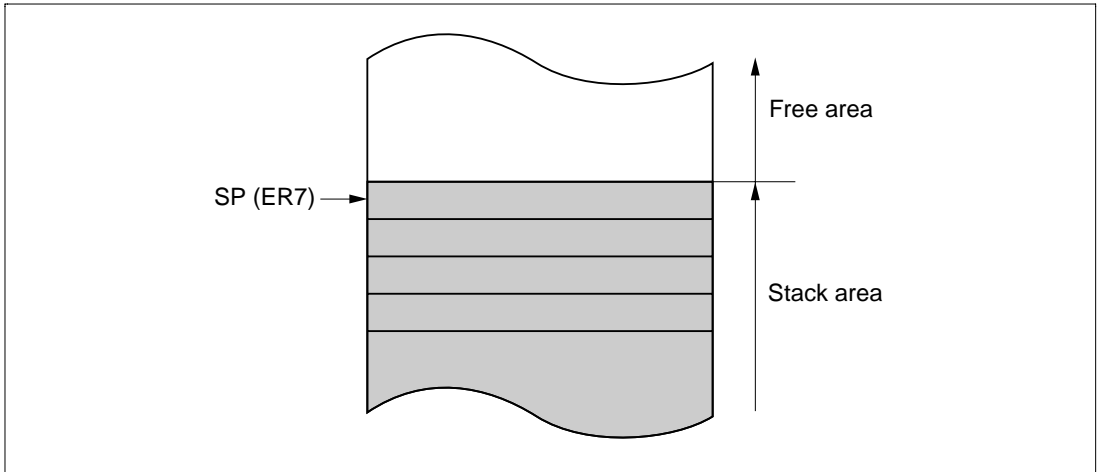

Figure 2-9 Stack

2.4.3 Control Registers

The control registers are the 24-bit program counter (PC), 8-bit extended control register (EXR), and 8-bit condition-code register (CCR).

(1) Program Counter (PC): This 24-bit counter indicates the address of the next instruction the CPU will execute. The length of all CPU instructions is 2 bytes (one word), so the least significant PC bit is ignored. (When an instruction is fetched, the least significant PC bit is regarded as 0.)

(2) Extended Control Register (EXR): This 8-bit register contains the trace bit (T) and three interrupt mask bits (I2 to I0).

Bit 7—Trace Bit (T): Selects trace mode. When this bit is cleared to 0, instructions are executed in sequence. When this bit is set to 1, a trace exception is generated each time an instruction is executed.

Bits 6 to 3—Reserved: These bits are reserved. They are always read as 1.

Bits 2 to 0—Interrupt Mask Bits (I2 to I0): These bits designate the interrupt mask level (0 to 7). For details, refer to section 5, Interrupt Controller.

Operations can be performed on the EXR bits by the LDC, STC, ANDC, ORC, and XORC instructions. All interrupts, including NMI, are disabled for three states after one of these instructions is executed, except for STC.

(3) Condition-Code Register (CCR): This 8-bit register contains internal CPU status information, including an interrupt mask bit (I) and half-carry (H), negative (N), zero (Z), overflow (V), and carry (C) flags.

Bit 7—Interrupt Mask Bit (I): Masks interrupts other than NMI when set to 1. (NMI is accepted regardless of the I bit setting.) The I bit is set to 1 by hardware at the start of an exception-handling sequence. For details, refer to section 5, Interrupt Controller.

Bit 6—User Bit or Interrupt Mask Bit (UI): Can be written and read by software using the LDC, STC, ANDC, ORC, and XORC instructions. With the H8S/2355 Series, this bit cannot be used as an interrupt mask bit.

Bit 5—Half-Carry Flag (H): When the ADD.B, ADDX.B, SUB.B, SUBX.B, CMP.B, or NEG.B instruction is executed, this flag is set to 1 if there is a carry or borrow at bit 3, and cleared to 0 otherwise. When the ADD.W, SUB.W, CMP.W, or NEG.W instruction is executed, the H flag is set to 1 if there is a carry or borrow at bit 11, and cleared to 0 otherwise. When the ADD.L, SUB.L, CMP.L, or NEG.L instruction is executed, the H flag is set to 1 if there is a carry or borrow at bit 27, and cleared to 0 otherwise.

Bit 4—User Bit (U): Can be written and read by software using the LDC, STC, ANDC, ORC, and XORC instructions.

Bit 3—Negative Flag (N): Stores the value of the most significant bit (sign bit) of data.

Bit 2—Zero Flag (Z): Set to 1 to indicate zero data, and cleared to 0 to indicate non-zero data.

Bit 1—Overflow Flag (V): Set to 1 when an arithmetic overflow occurs, and cleared to 0 at other times.

Bit 0—Carry Flag (C): Set to 1 when a carry occurs, and cleared to 0 otherwise. Used by:

- Add instructions, to indicate a carry
- Subtract instructions, to indicate a borrow
- Shift and rotate instructions, to store the value shifted out of the end bit

The carry flag is also used as a bit accumulator by bit manipulation instructions.

Some instructions leave some or all of the flag bits unchanged. For the action of each instruction on the flag bits, refer to Appendix A.1, List of Instructions.

Operations can be performed on the CCR bits by the LDC, STC, ANDC, ORC, and XORC instructions. The N, Z, V, and C flags are used as branching conditions for conditional branch (Bcc) instructions.

2.4.4 Initial Register Values

Reset exception handling loads the CPU's program counter (PC) from the vector table, clears the trace bit in EXR to 0, and sets the interrupt mask bits in CCR and EXR to 1. The other CCR bits and the general registers are not initialized. In particular, the stack pointer (ER7) is not initialized. The stack pointer should therefore be initialized by an MOV.L instruction executed immediately after a reset.

2.5 Data Formats

The CPU can process 1-bit, 4-bit (BCD), 8-bit (byte), 16-bit (word), and 32-bit (longword) data. Bit-manipulation instructions operate on 1-bit data by accessing bit n ($n = 0, 1, 2, \dots, 7$) of byte operand data. The DAA and DAS decimal-adjust instructions treat byte data as two digits of 4-bit BCD data.

2.5.1 General Register Data Formats

Figure 2-10 shows the data formats in general registers.

Data Type	Register Number	Data Format
1-bit data	RnH	<p>7 0 7 6 5 4 3 2 1 0 Don't care</p>
1-bit data	RnL	<p>7 0 Don't care 7 6 5 4 3 2 1 0</p>
4-bit BCD data	RnH	<p>7 4 3 0 Upper Lower Don't care</p>
4-bit BCD data	RnL	<p>7 4 3 0 Don't care Upper Lower</p>
Byte data	RnH	<p>7 0 MSB LSB Don't care</p>
Byte data	RnL	<p>7 0 Don't care MSB LSB</p>

Figure 2-10 General Register Data Formats

Data Type	Register Number	Data Format
Word data	Rn	
Word data	En	
Longword data	ERn	

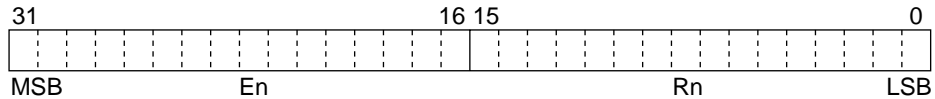
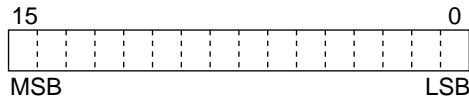
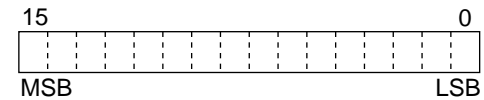

Legend

ERn: General register ER

En: General register E

Rn: General register R

RnH: General register RH

RnL: General register RL

MSB: Most significant bit

LSB: Least significant bit

Figure 2-10 General Register Data Formats (cont)

2.5.2 Memory Data Formats

Figure 2-11 shows the data formats in memory. The CPU can access word data and longword data in memory, but word or longword data must begin at an even address. If an attempt is made to access word or longword data at an odd address, no address error occurs but the least significant bit of the address is regarded as 0, so the access starts at the preceding address. This also applies to instruction fetches.

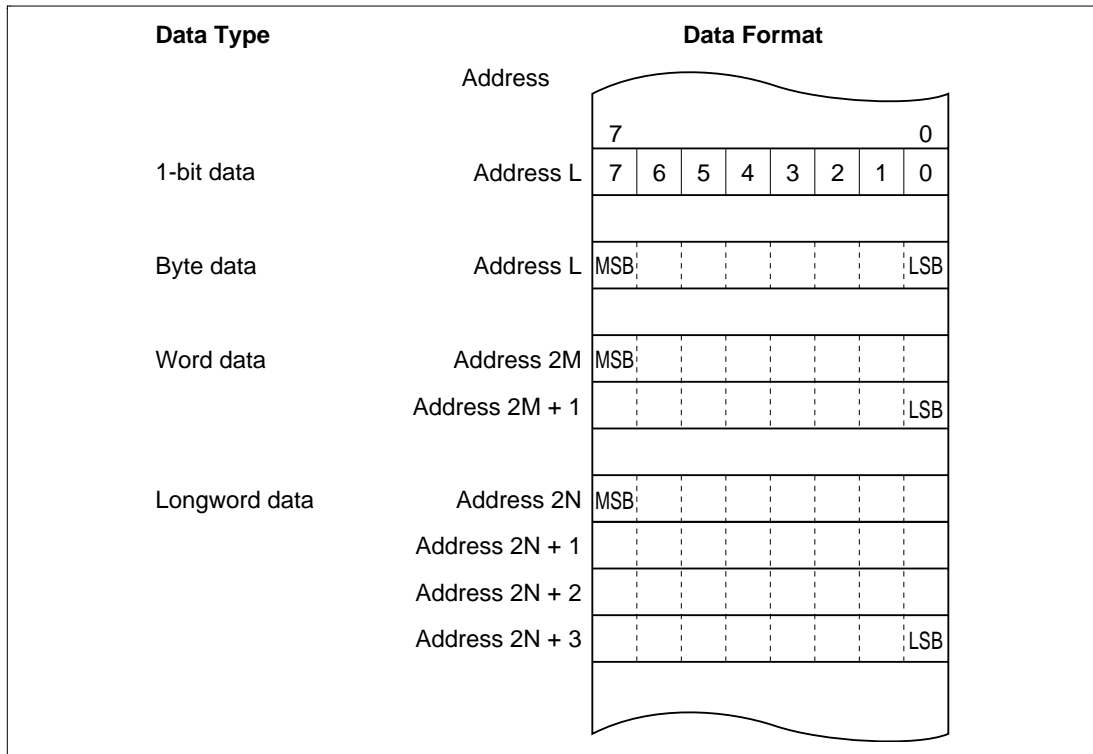

Figure 2-11 Memory Data Formats

When ER7 is used as an address register to access the stack, the operand size should be word size or longword size.

2.6 Instruction Set

2.6.1 Overview

The H8S/2000 CPU has 65 types of instructions. The instructions are classified by function in table 2-1.

Table 2-1 Instruction Classification

Function	Instructions	Size	Types
Data transfer	MOV	BWL	5
	POP* ¹ , PUSH* ¹	WL	
	LDM, STM	L	
	MOVFP, MOVTP* ³	B	
Arithmetic operations	ADD, SUB, CMP, NEG	BWL	19
	ADDX, SUBX, DAA, DAS	B	
	INC, DEC	BWL	
	ADDS, SUBS	L	
	MULXU, DIVXU, MULXS, DIVXS	BW	
	EXTU, EXTS	WL	
	TAS	B	
Logic operations	AND, OR, XOR, NOT	BWL	4
Shift	SHAL, SHAR, SHLL, SHLR, ROTL, ROTR, ROTXL, ROTXR	BWL	8
Bit manipulation	BSET, BCLR, BNOT, BTST, BLD, BILD, BST, BIST, BAND, BIAND, BOR, BIOR, BXOR, BIXOR	B	14
Branch	Bcc* ² , JMP, BSR, JSR, RTS	—	5
System control	TRAPA, RTE, SLEEP, LDC, STC, ANDC, ORC, XORC, NOP	—	9
Block data transfer	EEPMOV	—	1

Notes: B-byte size; W-word size; L-longword size.

1. POP.W Rn and PUSH.W Rn are identical to MOV.W @SP+, Rn and MOV.W Rn, @-SP. POP.L ERn and PUSH.L ERn are identical to MOV.L @SP+, ERn and MOV.L ERn, @-SP.
2. Bcc is the general name for conditional branch instructions.
3. Cannot be used in the H8S/2355 Series.

2.6.2 Instructions and Addressing Modes

Table 2-2 indicates the combinations of instructions and addressing modes that the H8S/2600 CPU can use.

Table 2-2 Combinations of Instructions and Addressing Modes

Function	Instruction	Addressing Modes													
		#xx	Rn	@ERn	@(d:16,ERn)	@(d:32,ERn)	@-ERn/@ERn+	@aa:8	@aa:16	@aa:24	@aa:32	@(d:8,PC)	@(d:16,PC)	@aa:8	—
Data transfer	MOV	BWL	BWL	BWL	BWL	BWL	BWL	B	BWL	—	BWL	—	—	—	—
	POP, PUSH	—	—	—	—	—	—	—	—	—	—	—	—	WL	—
	LDM, STM	—	—	—	—	—	—	—	—	—	—	—	—	L	—
	MOVFP, MOVTFP*	—	—	—	—	—	—	—	B	—	—	—	—	—	—
Arithmetic operations	ADD, CMP	BWL	BWL	—	—	—	—	—	—	—	—	—	—	—	—
	SUB	WL	BWL	—	—	—	—	—	—	—	—	—	—	—	—
	ADDX, SUBX	B	B	—	—	—	—	—	—	—	—	—	—	—	—
	ADDS, SUBS	—	L	—	—	—	—	—	—	—	—	—	—	—	—
	INC, DEC	—	BWL	—	—	—	—	—	—	—	—	—	—	—	—
	DAA, DAS	—	B	—	—	—	—	—	—	—	—	—	—	—	—
	MULXU,	—	BW	—	—	—	—	—	—	—	—	—	—	—	—
	DIVXU	—	—	—	—	—	—	—	—	—	—	—	—	—	—
	MULXS,	—	BW	—	—	—	—	—	—	—	—	—	—	—	—
	DIVXS	—	—	—	—	—	—	—	—	—	—	—	—	—	—
NEG	—	BWL	—	—	—	—	—	—	—	—	—	—	—	—	
EXTU, EXTS	—	WL	—	—	—	—	—	—	—	—	—	—	—	—	
TAS	—	—	B	—	—	—	—	—	—	—	—	—	—	—	

Note: * Cannot be used in the H8S/2355 Series.

2.6.3 Table of Instructions Classified by Function

Table 2-3 summarizes the instructions in each functional category. The notation used in table 2-3 is defined below.

Operation Notation

Rd	General register (destination)*
Rs	General register (source)*
Rn	General register*
ERn	General register (32-bit register)
(EAd)	Destination operand
(EAs)	Source operand
EXR	Extended control register
CCR	Condition-code register
N	N (negative) flag in CCR
Z	Z (zero) flag in CCR
V	V (overflow) flag in CCR
C	C (carry) flag in CCR
PC	Program counter
SP	Stack pointer
#IMM	Immediate data
disp	Displacement
+	Addition
-	Subtraction
×	Multiplication
÷	Division
^	Logical AND
∨	Logical OR
⊕	Logical exclusive OR
→	Move
¬	NOT (logical complement)
:8/:16/:24/:32	8-, 16-, 24-, or 32-bit length

Note: * General registers include 8-bit registers (R0H to R7H, R0L to R7L), 16-bit registers (R0 to R7, E0 to E7), and 32-bit registers (ER0 to ER7).

Table 2-3 Instructions Classified by Function

Type	Instruction	Size*	Function
Data transfer	MOV	B/W/L	(EAs) → Rd, Rs → (Ead) Moves data between two general registers or between a general register and memory, or moves immediate data to a general register.
	MOVFPE	B	Cannot be used in the H8S/2355 Series.
	MOVTPE	B	Cannot be used in the H8S/2355 Series.
	POP	W/L	@SP+ → Rn Pops a register from the stack. POP.W Rn is identical to MOV.W @SP+, Rn. POP.L ERn is identical to MOV.L @SP+, ERn.
	PUSH	W/L	Rn → @-SP Pushes a register onto the stack. PUSH.W Rn is identical to MOV.W Rn, @-SP. PUSH.L ERn is identical to MOV.L ERn, @-SP.
	LDM	L	@SP+ → Rn (register list) Pops two or more general registers from the stack.
	STM	L	Rn (register list) → @-SP Pushes two or more general registers onto the stack.

Type	Instruction	Size*	Function
Arithmetic operations	ADD SUB	B/W/L	$Rd \pm Rs \rightarrow Rd$, $Rd \pm \#IMM \rightarrow Rd$ Performs addition or subtraction on data in two general registers, or on immediate data and data in a general register. (Immediate byte data cannot be subtracted from byte data in a general register. Use the SUBX or ADD instruction.)
	ADDX SUBX	B	$Rd \pm Rs \pm C \rightarrow Rd$, $Rd \pm \#IMM \pm C \rightarrow Rd$ Performs addition or subtraction with carry or borrow on byte data in two general registers, or on immediate data and data in a general register.
	INC DEC	B/W/L	$Rd \pm 1 \rightarrow Rd$, $Rd \pm 2 \rightarrow Rd$ Increments or decrements a general register by 1 or 2. (Byte operands can be incremented or decremented by 1 only.)
	ADDS SUBS	L	$Rd \pm 1 \rightarrow Rd$, $Rd \pm 2 \rightarrow Rd$, $Rd \pm 4 \rightarrow Rd$ Adds or subtracts the value 1, 2, or 4 to or from data in a 32-bit register.
	DAA DAS	B	$Rd \text{ decimal adjust} \rightarrow Rd$ Decimal-adjusts an addition or subtraction result in a general register by referring to the CCR to produce 4-bit BCD data.
	MULXU	B/W	$Rd \times Rs \rightarrow Rd$ Performs unsigned multiplication on data in two general registers: either 8 bits \times 8 bits \rightarrow 16 bits or 16 bits \times 16 bits \rightarrow 32 bits.
	MULXS	B/W	$Rd \times Rs \rightarrow Rd$ Performs signed multiplication on data in two general registers: either 8 bits \times 8 bits \rightarrow 16 bits or 16 bits \times 16 bits \rightarrow 32 bits.
	DIVXU	B/W	$Rd \div Rs \rightarrow Rd$ Performs unsigned division on data in two general registers: either 16 bits \div 8 bits \rightarrow 8-bit quotient and 8-bit remainder or 32 bits \div 16 bits \rightarrow 16-bit quotient and 16-bit remainder.

Type	Instruction	Size*	Function
Arithmetic operations	DIVXS	B/W	$Rd \div Rs \rightarrow Rd$ Performs signed division on data in two general registers: either 16 bits \div 8 bits \rightarrow 8-bit quotient and 8-bit remainder or 32 bits \div 16 bits \rightarrow 16-bit quotient and 16-bit remainder.
	CMP	B/W/L	$Rd - Rs, Rd - \#IMM$ Compares data in a general register with data in another general register or with immediate data, and sets CCR bits according to the result.
	NEG	B/W/L	$0 - Rd \rightarrow Rd$ Takes the two's complement (arithmetic complement) of data in a general register.
	EXTU	W/L	Rd (zero extension) $\rightarrow Rd$ Extends the lower 8 bits of a 16-bit register to word size, or the lower 16 bits of a 32-bit register to longword size, by padding with zeros on the left.
	EXTS	W/L	Rd (sign extension) $\rightarrow Rd$ Extends the lower 8 bits of a 16-bit register to word size, or the lower 16 bits of a 32-bit register to longword size, by extending the sign bit.
	TAS	B	$@ERd - 0, 1 \rightarrow \langle \text{bit } 7 \rangle \text{ of } @ERd$ Tests memory contents, and sets the most significant bit (bit 7) to 1.

Type	Instruction	Size*	Function
Logic operations	AND	B/W/L	$Rd \wedge Rs \rightarrow Rd$, $Rd \wedge \#IMM \rightarrow Rd$ Performs a logical AND operation on a general register and another general register or immediate data.
	OR	B/W/L	$Rd \vee Rs \rightarrow Rd$, $Rd \vee \#IMM \rightarrow Rd$ Performs a logical OR operation on a general register and another general register or immediate data.
	XOR	B/W/L	$Rd \oplus Rs \rightarrow Rd$, $Rd \oplus \#IMM \rightarrow Rd$ Performs a logical exclusive OR operation on a general register and another general register or immediate data.
	NOT	B/W/L	$\neg (Rd) \rightarrow (Rd)$ Takes the one's complement of general register contents.
Shift operations	SHAL SHAR	B/W/L	$Rd \text{ (shift)} \rightarrow Rd$ Performs an arithmetic shift on general register contents. 1-bit or 2-bit shift is possible.
	SHLL SHLR	B/W/L	$Rd \text{ (shift)} \rightarrow Rd$ Performs a logical shift on general register contents. 1-bit or 2-bit shift is possible.
	ROTL ROTR	B/W/L	$Rd \text{ (rotate)} \rightarrow Rd$ Rotates general register contents. 1-bit or 2-bit rotation is possible.
	ROTXL ROTXR	B/W/L	$Rd \text{ (rotate)} \rightarrow Rd$ Rotates general register contents through the carry flag. 1-bit or 2-bit rotation is possible.

Type	Instruction	Size*	Function
Bit-manipulation instructions	BSET	B	$1 \rightarrow (\text{<bit-No.> of <EAd>})$ Sets a specified bit in a general register or memory operand to 1. The bit number is specified by 3-bit immediate data or the lower three bits of a general register.
	BCLR	B	$0 \rightarrow (\text{<bit-No.> of <EAd>})$ Clears a specified bit in a general register or memory operand to 0. The bit number is specified by 3-bit immediate data or the lower three bits of a general register.
	BNOT	B	$\neg (\text{<bit-No.> of <EAd>}) \rightarrow (\text{<bit-No.> of <EAd>})$ Inverts a specified bit in a general register or memory operand. The bit number is specified by 3-bit immediate data or the lower three bits of a general register.
	BTST	B	$\neg (\text{<bit-No.> of <EAd>}) \rightarrow Z$ Tests a specified bit in a general register or memory operand and sets or clears the Z flag accordingly. The bit number is specified by 3-bit immediate data or the lower three bits of a general register.
	BAND	B	$C \wedge (\text{<bit-No.> of <EAd>}) \rightarrow C$ ANDs the carry flag with a specified bit in a general register or memory operand and stores the result in the carry flag.
	BIAND	B	$C \wedge \neg (\text{<bit-No.> of <EAd>}) \rightarrow C$ ANDs the carry flag with the inverse of a specified bit in a general register or memory operand and stores the result in the carry flag. The bit number is specified by 3-bit immediate data.
	BOR	B	$C \vee (\text{<bit-No.> of <EAd>}) \rightarrow C$ ORs the carry flag with a specified bit in a general register or memory operand and stores the result in the carry flag.
	BIOR	B	$C \vee \neg (\text{<bit-No.> of <EAd>}) \rightarrow C$ ORs the carry flag with the inverse of a specified bit in a general register or memory operand and stores the result in the carry flag. The bit number is specified by 3-bit immediate data.

Type	Instruction	Size*	Function
Bit-manipulation instructions	BXOR	B	$C \oplus (\text{<bit-No.> of <EAd>}) \rightarrow C$ Exclusive-ORs the carry flag with a specified bit in a general register or memory operand and stores the result in the carry flag.
	BIXOR	B	$C \oplus \neg (\text{<bit-No.> of <EAd>}) \rightarrow C$ Exclusive-ORs the carry flag with the inverse of a specified bit in a general register or memory operand and stores the result in the carry flag. The bit number is specified by 3-bit immediate data.
	BLD	B	$(\text{<bit-No.> of <EAd>}) \rightarrow C$ Transfers a specified bit in a general register or memory operand to the carry flag.
	BILD	B	$\neg (\text{<bit-No.> of <EAd>}) \rightarrow C$ Transfers the inverse of a specified bit in a general register or memory operand to the carry flag. The bit number is specified by 3-bit immediate data.
	BST	B	$C \rightarrow (\text{<bit-No.> of <EAd>})$ Transfers the carry flag value to a specified bit in a general register or memory operand.
	BIST	B	$\neg C \rightarrow (\text{<bit-No.> of <EAd>})$ Transfers the inverse of the carry flag value to a specified bit in a general register or memory operand. The bit number is specified by 3-bit immediate data.

Type	Instruction	Size*	Function		
Branch instructions	Bcc	—	Branches to a specified address if a specified condition is true. The branching conditions are listed below.		
			Mnemonic	Description	Condition
			BRA(BT)	Always (true)	Always
			BRN(BF)	Never (false)	Never
			BHI	High	$C \vee Z = 0$
			BLS	Low or same	$C \vee Z = 1$
			BCC(BHS)	Carry clear (high or same)	$C = 0$
			BCS(BLO)	Carry set (low)	$C = 1$
			BNE	Not equal	$Z = 0$
			BEQ	Equal	$Z = 1$
			BVC	Overflow clear	$V = 0$
			BVS	Overflow set	$V = 1$
			BPL	Plus	$N = 0$
			BMI	Minus	$N = 1$
			BGE	Greater or equal	$N \oplus V = 0$
			BLT	Less than	$N \oplus V = 1$
			BGT	Greater than	$Z \vee (N \oplus V) = 0$
BLE	Less or equal	$Z \vee (N \oplus V) = 1$			
JMP	—	Branches unconditionally to a specified address.			
BSR	—	Branches to a subroutine at a specified address.			
JSR	—	Branches to a subroutine at a specified address.			
RTS	—	Returns from a subroutine			

Type	Instruction	Size*	Function
System control instructions	TRAPA	—	Starts trap-instruction exception handling.
	RTE	—	Returns from an exception-handling routine.
	SLEEP	—	Causes a transition to a power-down state.
	LDC	B/W	(EAs) → CCR, (EAs) → EXR Moves the source operand contents or immediate data to CCR or EXR. Although CCR and EXR are 8-bit registers, word-size transfers are performed between them and memory. The upper 8 bits are valid.
	STC	B/W	CCR → (EAd), EXR → (EAd) Transfers CCR or EXR contents to a general register or memory. Although CCR and EXR are 8-bit registers, word-size transfers are performed between them and memory. The upper 8 bits are valid.
	ANDC	B	CCR ∧ #IMM → CCR, EXR ∧ #IMM → EXR Logically ANDs the CCR or EXR contents with immediate data.
	ORC	B	CCR ∨ #IMM → CCR, EXR ∨ #IMM → EXR Logically ORs the CCR or EXR contents with immediate data.
	XORC	B	CCR ⊕ #IMM → CCR, EXR ⊕ #IMM → EXR Logically exclusive-ORs the CCR or EXR contents with immediate data.
NOP	—	PC + 2 → PC Only increments the program counter.	

Type	Instruction	Size*	Function
Block data transfer instruction	EEPMOV.B	—	if R4L ≠ 0 then Repeat @ER5+ → @ER6+ R4L-1 → R4L Until R4L = 0 else next;
	EEPMOV.W	—	if R4 ≠ 0 then Repeat @ER5+ → @ER6+ R4-1 → R4 Until R4 = 0 else next; <p>Transfers a data block according to parameters set in general registers R4L or R4, ER5, and ER6.</p> <p>R4L or R4: size of block (bytes) ER5: starting source address ER6: starting destination address</p> <p>Execution of the next instruction begins as soon as the transfer is completed.</p>

Note: * Size refers to the operand size.

- B: Byte
- W: Word
- L: Longword

2.6.4 Basic Instruction Formats

The CPU instructions consist of 2-byte (1-word) units. An instruction consists of an operation field (op field), a register field (r field), an effective address extension (EA field), and a condition field (cc).

Figure 2-12 shows examples of instruction formats.

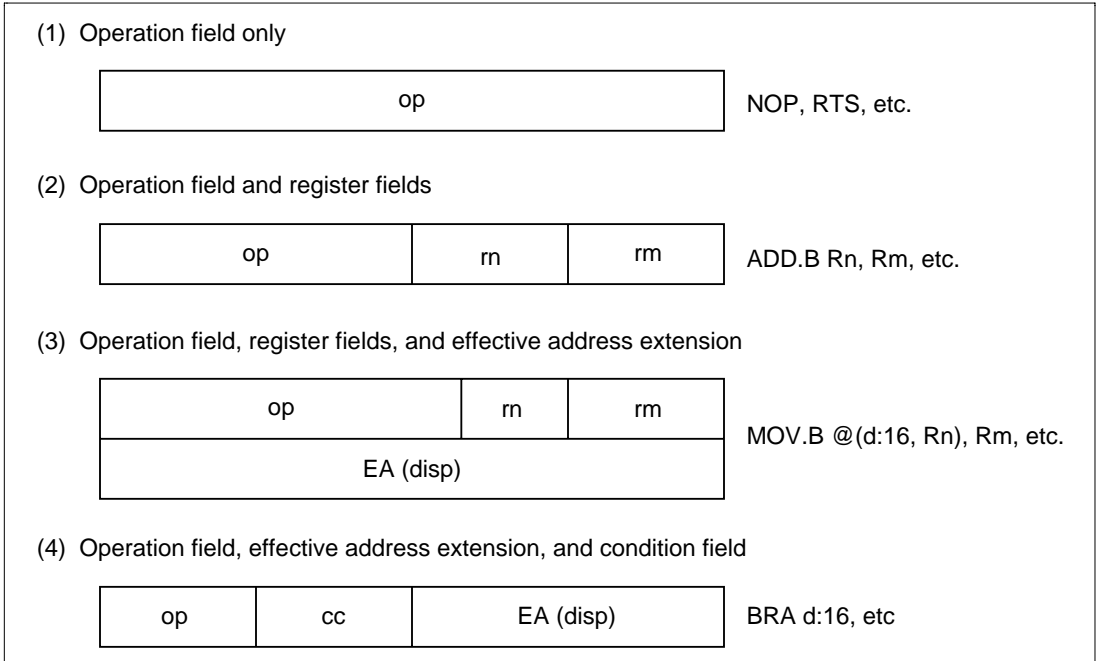

Figure 2-12 Instruction Formats (Examples)

(1) Operation Field: Indicates the function of the instruction, the addressing mode, and the operation to be carried out on the operand. The operation field always includes the first four bits of the instruction. Some instructions have two operation fields.

(2) Register Field: Specifies a general register. Address registers are specified by 3 bits, data registers by 3 bits or 4 bits. Some instructions have two register fields. Some have no register field.

(3) Effective Address Extension: Eight, 16, or 32 bits specifying immediate data, an absolute address, or a displacement.

(4) Condition Field: Specifies the branching condition of Bcc instructions.

2.7 Addressing Modes and Effective Address Calculation

2.7.1 Addressing Mode

The CPU supports the eight addressing modes listed in table 2-4. Each instruction uses a subset of these addressing modes. Arithmetic and logic instructions can use the register direct and immediate modes. Data transfer instructions can use all addressing modes except program-counter relative and memory indirect. Bit manipulation instructions use register direct, register indirect, or absolute addressing mode to specify an operand, and register direct (BSET, BCLR, BNOT, and BTST instructions) or immediate (3-bit) addressing mode to specify a bit number in the operand.

Table 2-4 Addressing Modes

No.	Addressing Mode	Symbol
1	Register direct	Rn
2	Register indirect	@ERn
3	Register indirect with displacement	@(d:16,ERn)/@(d:32,ERn)
4	Register indirect with post-increment Register indirect with pre-decrement	@ERn+ @-ERn
5	Absolute address	@aa:8/@aa:16/@aa:24/@aa:32
6	Immediate	#xx:8/#xx:16/#xx:32
7	Program-counter relative	@(d:8,PC)/@(d:16,PC)
8	Memory indirect	@@aa:8

(1) **Register Direct—Rn:** The register field of the instruction specifies an 8-, 16-, or 32-bit general register containing the operand. R0H to R7H and R0L to R7L can be specified as 8-bit registers. R0 to R7 and E0 to E7 can be specified as 16-bit registers. ER0 to ER7 can be specified as 32-bit registers.

(2) **Register Indirect—@ERn:** The register field of the instruction code specifies an address register (ERn) which contains the address of the operand on memory. If the address is a program instruction address, the lower 24 bits are valid and the upper 8 bits are all assumed to be 0 (H'00).

(3) **Register Indirect with Displacement—@(d:16, ERn) or @(d:32, ERn):** A 16-bit or 32-bit displacement contained in the instruction is added to an address register (ERn) specified by the register field of the instruction, and the sum gives the address of a memory operand. A 16-bit displacement is sign-extended when added.

(4) Register Indirect with Post-Increment or Pre-Decrement—@ERn+ or @-ERn:

- Register indirect with post-increment—@ERn+

The register field of the instruction code specifies an address register (ERn) which contains the address of a memory operand. After the operand is accessed, 1, 2, or 4 is added to the address register contents and the sum is stored in the address register. The value added is 1 for byte access, 2 for word transfer instruction, or 4 for longword transfer instruction. For word or longword transfer instruction, the register value should be even.

- Register indirect with pre-decrement—@-ERn

The value 1, 2, or 4 is subtracted from an address register (ERn) specified by the register field in the instruction code, and the result becomes the address of a memory operand. The result is also stored in the address register. The value subtracted is 1 for byte access, 2 for word transfer instruction, or 4 for longword transfer instruction. For word or longword transfer instruction, the register value should be even.

(5) Absolute Address—@aa:8, @aa:16, @aa:24, or @aa:32: The instruction code contains the absolute address of a memory operand. The absolute address may be 8 bits long (@aa:8), 16 bits long (@aa:16), 24 bits long (@aa:24), or 32 bits long (@aa:32).

To access data, the absolute address should be 8 bits (@aa:8), 16 bits (@aa:16), or 32 bits (@aa:32) long. For an 8-bit absolute address, the upper 24 bits are all assumed to be 1 (H'FFFF). For a 16-bit absolute address the upper 16 bits are a sign extension. A 32-bit absolute address can access the entire address space.

A 24-bit absolute address (@aa:24) indicates the address of a program instruction. The upper 8 bits are all assumed to be 0 (H'00).

Table 2-5 indicates the accessible absolute address ranges.

Table 2-5 Absolute Address Access Ranges

Absolute Address		Normal Mode	Advanced Mode
Data address	8 bits (@aa:8)	H'FF00 to H'FFFF	H'FFFF00 to H'FFFFFF
	16 bits (@aa:16)	H'0000 to H'FFFF	H'000000 to H'007FFF, H'FF8000 to H'FFFFFF
	32 bits (@aa:32)		H'000000 to H'FFFFFF
Program instruction address	24 bits (@aa:24)		

(6) Immediate—#xx:8, #xx:16, or #xx:32: The instruction contains 8-bit (#xx:8), 16-bit (#xx:16), or 32-bit (#xx:32) immediate data as an operand.

The ADDS, SUBS, INC, and DEC instructions contain immediate data implicitly. Some bit manipulation instructions contain 3-bit immediate data in the instruction code, specifying a bit number. The TRAPA instruction contains 2-bit immediate data in its instruction code, specifying a vector address.

(7) Program-Counter Relative—@(d:8, PC) or @(d:16, PC): This mode is used in the Bcc and BSR instructions. An 8-bit or 16-bit displacement contained in the instruction is sign-extended and added to the 24-bit PC contents to generate a branch address. Only the lower 24 bits of this branch address are valid; the upper 8 bits are all assumed to be 0 (H'00). The PC value to which the displacement is added is the address of the first byte of the next instruction, so the possible branching range is -126 to +128 bytes (-63 to +64 words) or -32766 to +32768 bytes (-16383 to +16384 words) from the branch instruction. The resulting value should be an even number.

(8) Memory Indirect—@@aa:8: This mode can be used by the JMP and JSR instructions. The instruction code contains an 8-bit absolute address specifying a memory operand. This memory operand contains a branch address. The upper bits of the absolute address are all assumed to be 0, so the address range is 0 to 255 (H'0000 to H'00FF in normal mode, H'000000 to H'0000FF in advanced mode). In normal mode the memory operand is a word operand and the branch address is 16 bits long. In advanced mode the memory operand is a longword operand, the first byte of which is assumed to be all 0 (H'00).

Note that the first part of the address range is also the exception vector area. For further details, refer to section 4, Exception Handling.

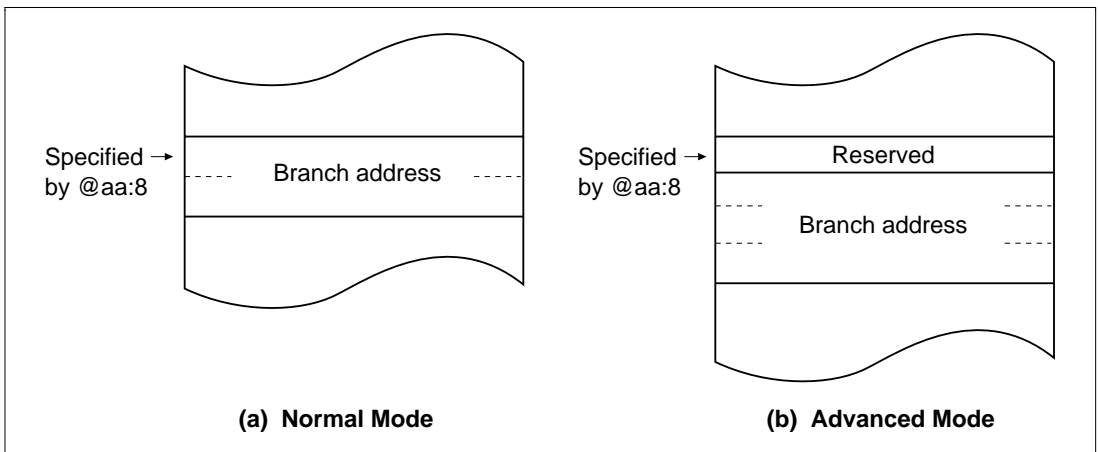

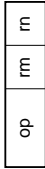

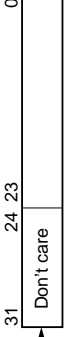

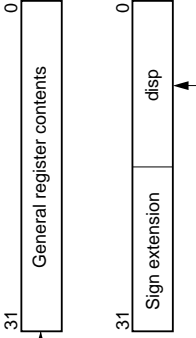
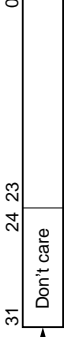

Figure 2-13 Branch Address Specification in Memory Indirect Mode

If an odd address is specified in word or longword memory access, or as a branch address, the least significant bit is regarded as 0, causing data to be accessed or instruction code to be fetched at the address preceding the specified address. (For further information, see section 2.5.2, Memory Data Formats.)



2.7.2 Effective Address Calculation

Table 2-6 indicates how effective addresses are calculated in each addressing mode. In normal mode the upper 8 bits of the effective address are ignored in order to generate a 16-bit address.

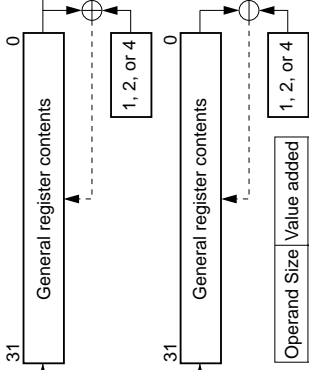
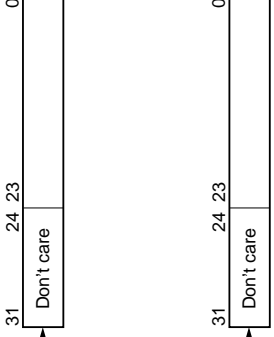
Table 2-6 Effective Address Calculation

No.	Addressing Mode and Instruction Format	Effective Address Calculation	Effective Address (EA)								
1	Register direct (Rn) 		Operand is general register contents.								
2	Register indirect (@ERn) 										
3	Register indirect with displacement @(d:16, ERn) or @(d:32, ERn) 										
4	Register indirect with post-increment or pre-decrement • Register indirect with post-increment @ERn+  • Register indirect with pre-decrement @-ERn 	 <table border="1" data-bbox="990 584 1099 810"> <thead> <tr> <th>Operand Size</th> <th>Value added</th> </tr> </thead> <tbody> <tr> <td>Byte</td> <td>1</td> </tr> <tr> <td>Word</td> <td>2</td> </tr> <tr> <td>Longword</td> <td>4</td> </tr> </tbody> </table>	Operand Size	Value added	Byte	1	Word	2	Longword	4	
Operand Size	Value added										
Byte	1										
Word	2										
Longword	4										

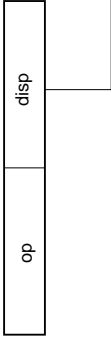
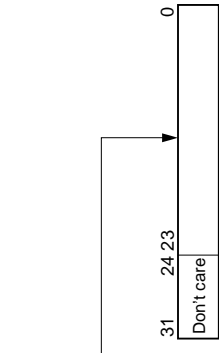
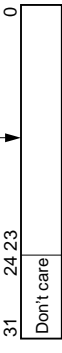
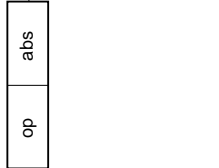
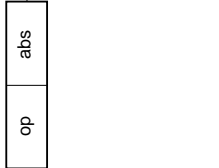
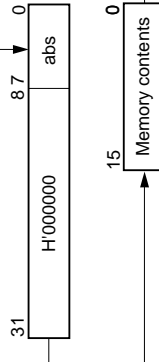
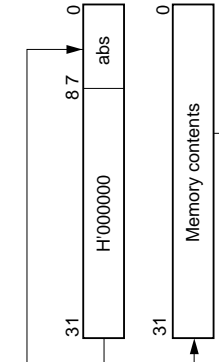
No.	Addressing Mode and Instruction Format	Effective Address Calculation	Effective Address (EA)
5	Absolute address @aa:8 <div style="display: flex; border: 1px solid black; padding: 2px;"> <div style="border-right: 1px solid black; width: 50%; text-align: center;">op</div> <div style="width: 50%; text-align: center;">abs</div> </div>		<div style="display: flex; border: 1px solid black; padding: 2px;"> <div style="border-right: 1px solid black; width: 50%; text-align: center;">Don't care</div> <div style="width: 50%; text-align: center;">H'FFFF</div> </div>
	@aa:16 <div style="display: flex; border: 1px solid black; padding: 2px;"> <div style="border-right: 1px solid black; width: 50%; text-align: center;">op</div> <div style="width: 50%; text-align: center;">abs</div> </div>		<div style="display: flex; border: 1px solid black; padding: 2px;"> <div style="border-right: 1px solid black; width: 50%; text-align: center;">Don't care</div> <div style="width: 50%; text-align: center;">Sign extension</div> </div>
	@aa:24 <div style="display: flex; border: 1px solid black; padding: 2px;"> <div style="border-right: 1px solid black; width: 50%; text-align: center;">op</div> <div style="width: 50%; text-align: center;">abs</div> </div>		<div style="display: flex; border: 1px solid black; padding: 2px;"> <div style="border-right: 1px solid black; width: 50%; text-align: center;">Don't care</div> <div style="width: 50%; text-align: center;">0</div> </div>
	@aa:32 <div style="display: flex; border: 1px solid black; padding: 2px;"> <div style="border-right: 1px solid black; width: 50%; text-align: center;">op</div> <div style="width: 50%; text-align: center;">abs</div> </div>		<div style="display: flex; border: 1px solid black; padding: 2px;"> <div style="border-right: 1px solid black; width: 50%; text-align: center;">Don't care</div> <div style="width: 50%; text-align: center;">0</div> </div>
6	Immediate #xx:8/#xx:16/#xx:32 <div style="display: flex; border: 1px solid black; padding: 2px;"> <div style="border-right: 1px solid black; width: 50%; text-align: center;">op</div> <div style="width: 50%; text-align: center;">IMM</div> </div>		Operand is immediate data.

No.	Addressing Mode and Instruction Format	Effective Address Calculation	Effective Address (EA)
7	<p>Program-counter relative @(d:8, PC)/@(d:16, PC)</p> 		
8	<p>Memory indirect @@aa:8</p> <ul style="list-style-type: none"> Normal mode  <ul style="list-style-type: none"> Advanced mode 	 	 

2.8 Processing States

2.8.1 Overview

The CPU has five main processing states: the reset state, exception handling state, program execution state, bus-released state, and power-down state. Figure 2-14 shows a diagram of the processing states. Figure 2-15 indicates the state transitions.

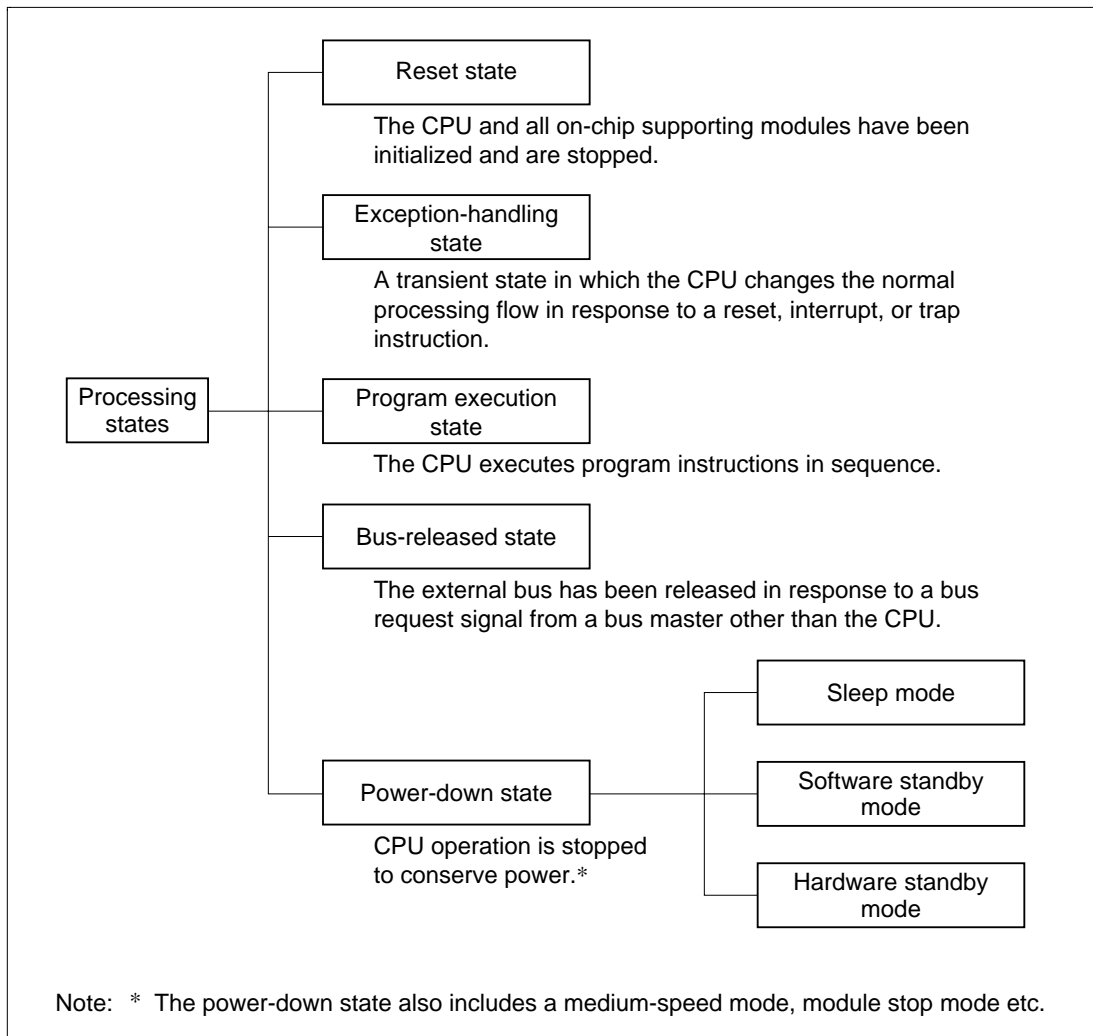

Figure 2-14 Processing States

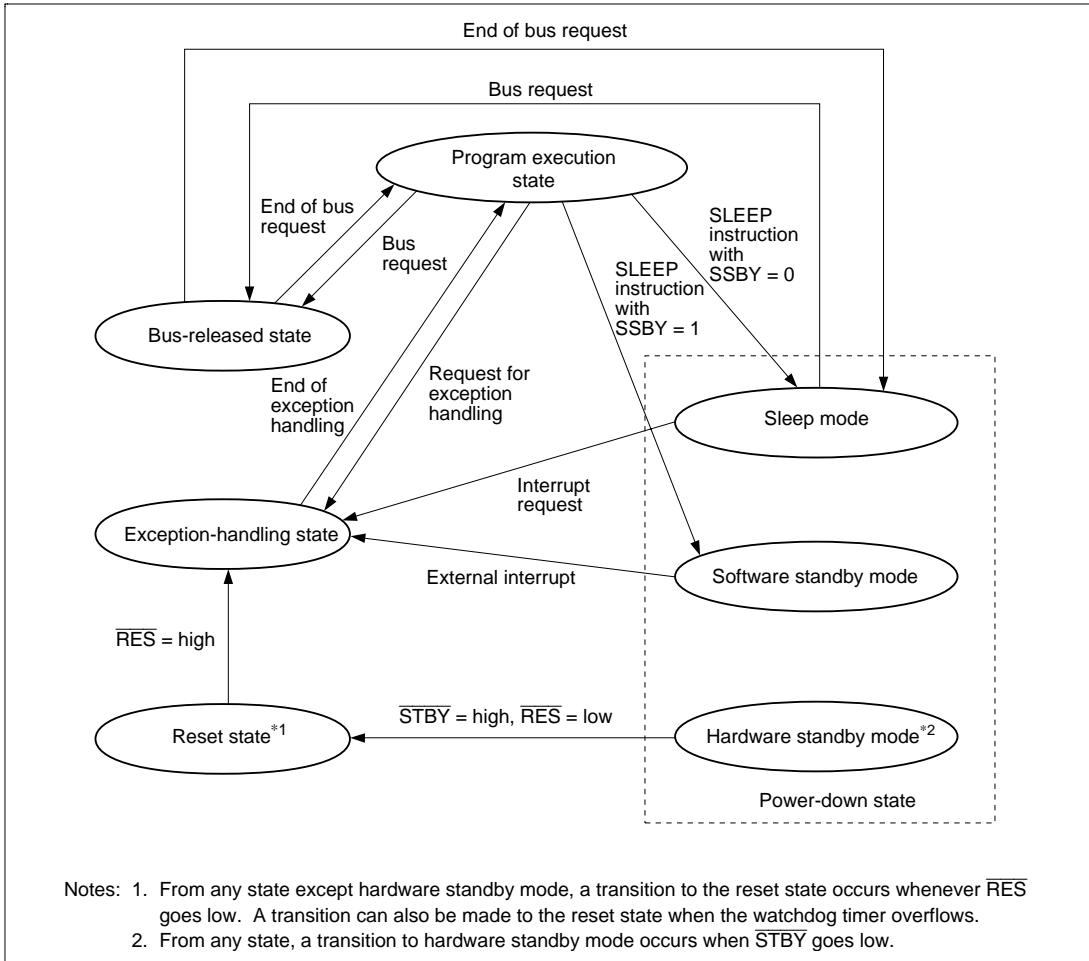

Figure 2-15 State Transitions

2.8.2 Reset State

When the \overline{RES} input goes low all current processing stops and the CPU enters the reset state. The CPU enters the power-on reset state when the NMI pin is high, or the manual reset state when the NMI pin is low. All interrupts are masked in the reset state. Reset exception handling starts when the \overline{RES} signal changes from low to high.

The reset state can also be entered by a watchdog timer overflow. For details, refer to section 11, Watchdog Timer.

2.8.3 Exception-Handling State

The exception-handling state is a transient state that occurs when the CPU alters the normal processing flow due to a reset, interrupt, or trap instruction. The CPU fetches a start address (vector) from the exception vector table and branches to that address.

(1) Types of Exception Handling and Their Priority

Exception handling is performed for traces, resets, interrupts, and trap instructions. Table 2-7 indicates the types of exception handling and their priority. Trap instruction exception handling is always accepted, in the program execution state.

Exception handling and the stack structure depend on the interrupt control mode set in SYSCR.

Table 2-7 Exception Handling Types and Priority

Priority	Type of Exception	Detection Timing	Start of Exception Handling
High	Reset	Synchronized with clock	Exception handling starts immediately after a low-to-high transition at the $\overline{\text{RES}}$ pin, or when the watchdog timer overflows.
	Trace	End of instruction execution or end of exception-handling sequence* ¹	When the trace (T) bit is set to 1, the trace starts at the end of the current instruction or current exception-handling sequence
	Interrupt	End of instruction execution or end of exception-handling sequence* ²	When an interrupt is requested, exception handling starts at the end of the current instruction or current exception-handling sequence
Low	Trap instruction	When TRAPA instruction is executed	Exception handling starts when a trap (TRAPA) instruction is executed* ³

- Notes: 1. Traces are enabled only in interrupt control mode 2. Trace exception-handling is not executed at the end of the RTE instruction.
2. Interrupts are not detected at the end of the ANDC, ORC, XORC, and LDC instructions, or immediately after reset exception handling.
3. Trap instruction exception handling is always accepted, in the program execution state.

(2) Reset Exception Handling

After the $\overline{\text{RES}}$ pin has gone low and the reset state has been entered, when $\overline{\text{RES}}$ goes high again, reset exception handling starts. The CPU enters the power-on reset state when the NMI pin is high, or the manual reset state when the NMI pin is low. When reset exception handling starts the CPU fetches a start address (vector) from the exception vector table and starts program execution from that address. All interrupts, including NMI, are disabled during reset exception handling and after it ends.

(3) Traces

Traces are enabled only in interrupt control mode 2. Trace mode is entered when the T bit of EXR is set to 1. When trace mode is established, trace exception handling starts at the end of each instruction.

At the end of a trace exception-handling sequence, the T bit of EXR is cleared to 0 and trace mode is cleared. Interrupt masks are not affected.

The T bit saved on the stack retains its value of 1, and when the RTE instruction is executed to return from the trace exception-handling routine, trace mode is entered again. Trace exception-handling is not executed at the end of the RTE instruction.

Trace mode is not entered in interrupt control mode 0, regardless of the state of the T bit.

(4) Interrupt Exception Handling and Trap Instruction Exception Handling

When interrupt or trap-instruction exception handling begins, the CPU references the stack pointer (ER7) and pushes the program counter and other control registers onto the stack. Next, the CPU alters the settings of the interrupt mask bits in the control registers. Then the CPU fetches a start address (vector) from the exception vector table and program execution starts from that start address.

Figure 2-16 shows the stack after exception handling ends.

Normal mode

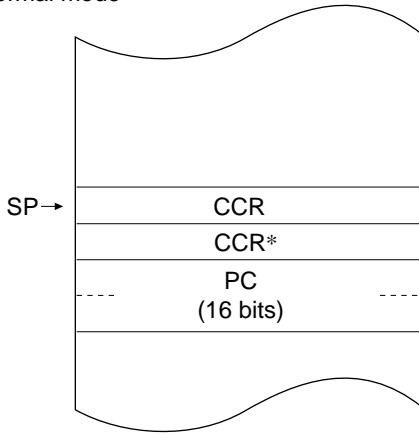

(a) Interrupt control mode 0

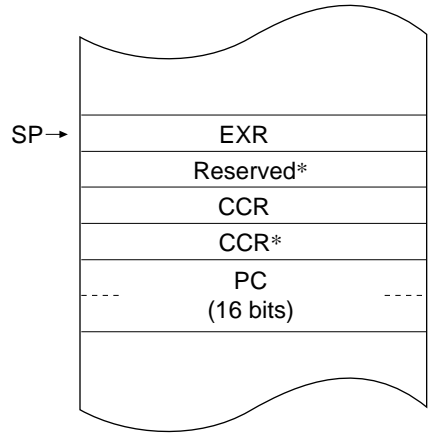

(b) Interrupt control mode 2

Advanced mode

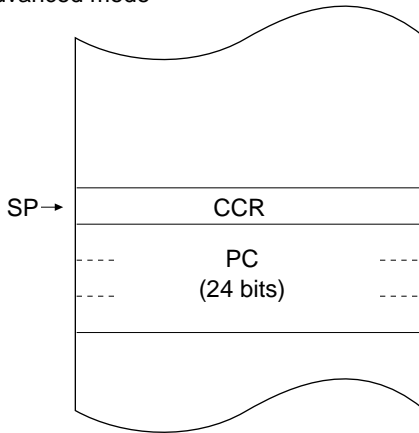

(c) Interrupt control mode 0

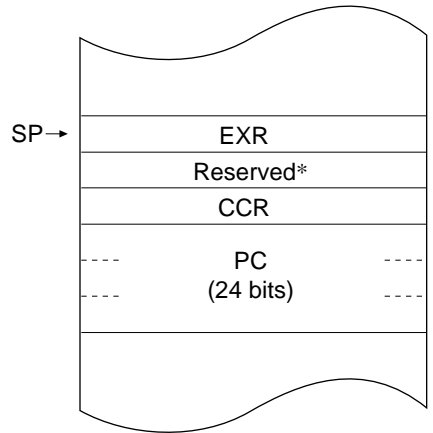

(d) Interrupt control mode 2

Note: *Ignored when returning.

Figure 2-16 Stack Structure after Exception Handling (Examples)

2.8.4 Program Execution State

In this state the CPU executes program instructions in sequence.

2.8.5 Bus-Released State

This is a state in which the bus has been released in response to a bus request from a bus master other than the CPU. While the bus is released, the CPU halts operations.

There is one other bus master in addition to the CPU: the data transfer controller (DTC).

For further details, refer to section 6, Bus Controller.

2.8.6 Power-Down State

The power-down state includes both modes in which the CPU stops operating and modes in which the CPU does not stop. There are three modes in which the CPU stops operating: sleep mode, software standby mode, and hardware standby mode. There are also two other power-down modes: medium-speed mode, and module stop mode. In medium-speed mode the CPU and other bus masters operate on a medium-speed clock. Module stop mode permits halting of the operation of individual modules, other than the CPU. For details, refer to section 19, Power-Down State.

(1) Sleep Mode: A transition to sleep mode is made if the SLEEP instruction is executed while the software standby bit (SSBY) in the standby control register (SBYCR) is cleared to 0. In sleep mode, CPU operations stop immediately after execution of the SLEEP instruction. The contents of CPU registers are retained.

(2) Software Standby Mode: A transition to software standby mode is made if the SLEEP instruction is executed while the SSBY bit in SBYCR is set to 1. In software standby mode, the CPU and clock halt and all MCU operations stop. As long as a specified voltage is supplied, the contents of CPU registers and on-chip RAM are retained. The I/O ports also remain in their existing states.

(3) Hardware Standby Mode: A transition to hardware standby mode is made when the $\overline{\text{STBY}}$ pin goes low. In hardware standby mode, the CPU and clock halt and all MCU operations stop. The on-chip supporting modules are reset, but as long as a specified voltage is supplied, on-chip RAM contents are retained.

2.9 Basic Timing

2.9.1 Overview

The CPU is driven by a system clock, denoted by the symbol ϕ . The period from one rising edge of ϕ to the next is referred to as a "state." The memory cycle or bus cycle consists of one, two, or three states. Different methods are used to access on-chip memory, on-chip supporting modules, and the external address space.

2.9.2 On-Chip Memory (ROM, RAM)

On-chip memory is accessed in one state. The data bus is 16 bits wide, permitting both byte and word transfer instruction. Figure 2-17 shows the on-chip memory access cycle. Figure 2-18 shows the pin states.

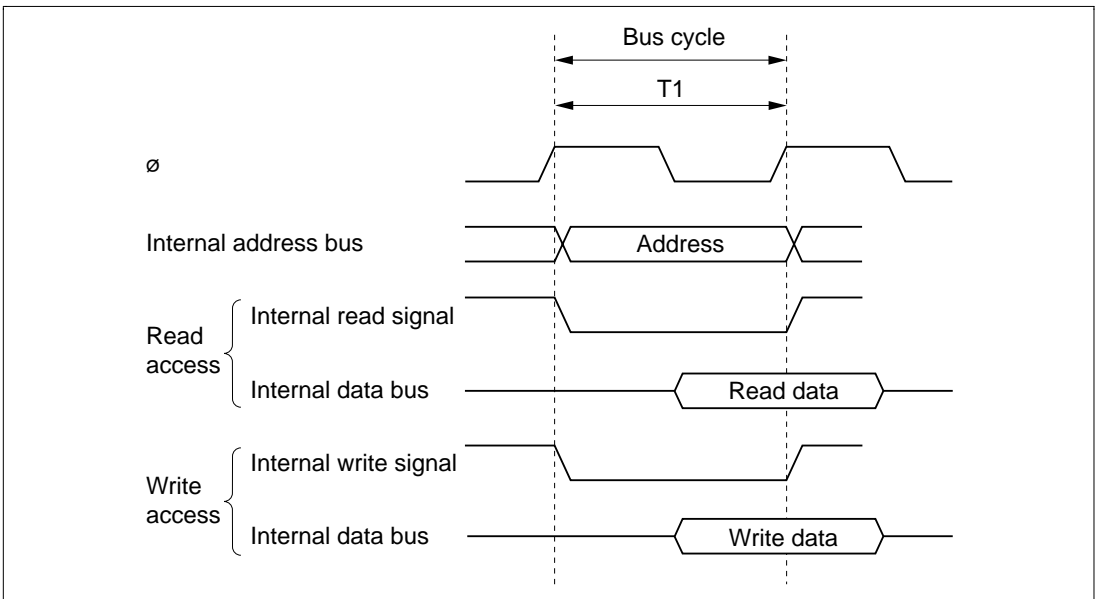

Figure 2-17 On-Chip Memory Access Cycle

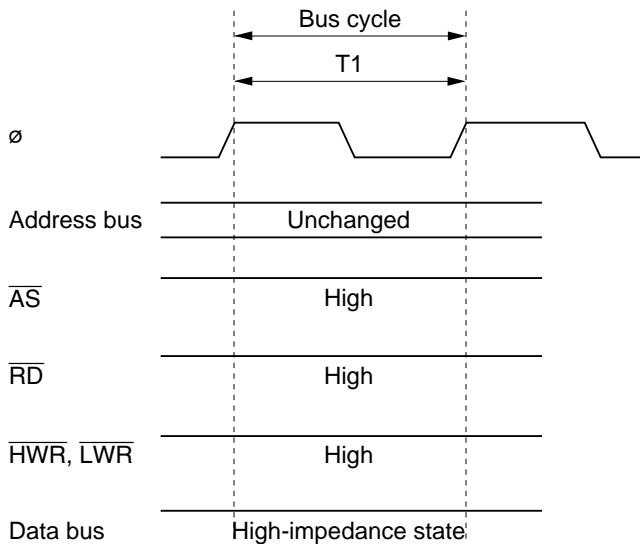

Figure 2-18 Pin States during On-Chip Memory Access

2.9.3 On-Chip Supporting Module Access Timing

The on-chip supporting modules are accessed in two states. The data bus is either 8 bits or 16 bits wide, depending on the particular internal I/O register being accessed. Figure 2-19 shows the access timing for the on-chip supporting modules. Figure 2-20 shows the pin states.

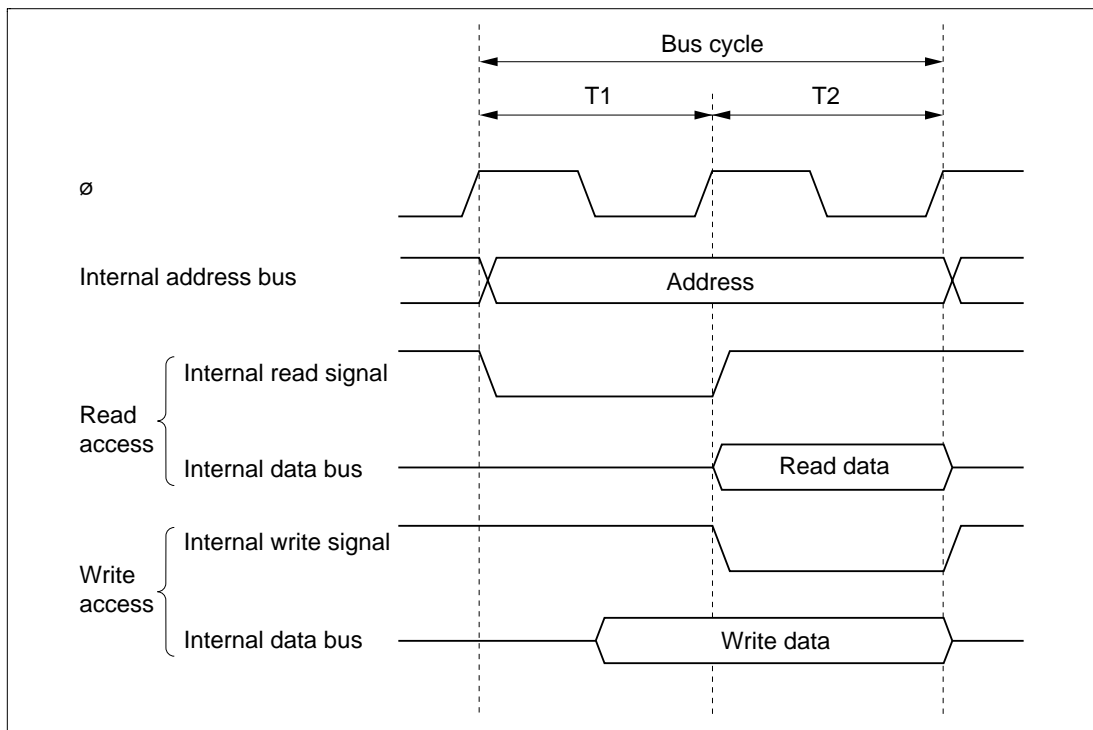

Figure 2-19 On-Chip Supporting Module Access Cycle

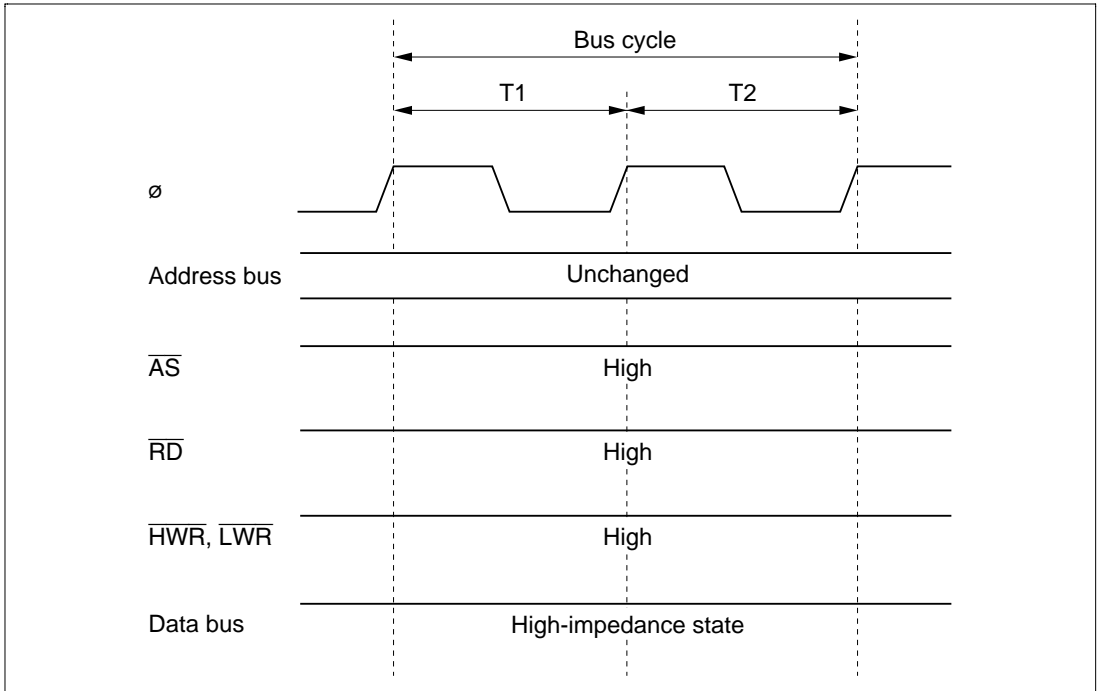

Figure 2-20 Pin States during On-Chip Supporting Module Access

2.9.4 External Address Space Access Timing

The external address space is accessed with an 8-bit or 16-bit data bus width in a two-state or three-state bus cycle. In three-state access, wait states can be inserted. For further details, refer to section 6, Bus Controller.

Section 3 MCU Operating Modes

3.1 Overview

3.1.1 Operating Mode Selection

The H8S/2355 Series has seven operating modes (modes 1 to 7). These modes enable selection of the CPU operating mode, enabling/disabling of on-chip ROM, and the initial bus width setting, by setting the mode pins (MD₂ to MD₀).

Table 3-1 lists the MCU operating modes.

Table 3-1 MCU Operating Mode Selection

MCU Operating Mode	MD ₂	MD ₁	MD ₀	CPU Operating Mode	Description	External Data Bus	
						On-Chip ROM	Initial Width
0	0	0	0	—	—	—	—
1			1	Normal	On-chip ROM disabled, Disabled expanded mode	8 bits	16 bits
2		1	0		On-chip ROM enabled, Enabled expanded mode	8 bits	16 bits
3			1		Single-chip mode	—	—
4	1	0	0	Advanced	On-chip ROM disabled, Disabled expanded mode	16 bits	16 bits
5			1			8 bits	16 bits
6		1	0		On-chip ROM enabled, Enabled expanded mode	8 bits	16 bits
7			1		Single-chip mode	—	—

The CPU's architecture allows for 4 Gbytes of address space, but the H8S/2355 Series actually accesses a maximum of 16 Mbytes.

Modes 1, 2, and 4 to 6 are externally expanded modes that allow access to external memory and peripheral devices.

The external expansion modes allow switching between 8-bit and 16-bit bus modes. After program execution starts, an 8-bit or 16-bit address space can be set for each area, depending on the bus controller setting. If 16-bit access is selected for any one area, 16-bit bus mode is set; if 8-bit access is selected for all areas, 8-bit bus mode is set.

Note that the functions of each pin depend on the operating mode.

The H8S/2355 Series can be used only in modes 1 to 7. This means that the mode pins must be set to select one of these modes. Do not change the inputs at the mode pins during operation.

3.1.2 Register Configuration

The H8S/2355 Series has a mode control register (MDCR) that indicates the inputs at the mode pins (MD_2 to MD_0), and a system control register (SYSCR) that controls the operation of the H8S/2355 Series. Table 3-2 summarizes these registers.

Table 3-2 MCU Registers

Name	Abbreviation	R/W	Initial Value	Address*
Mode control register	MDCR	R	Undetermined	H'FF3B
System control register	SYSCR	R/W	H'01	H'FF39

Note: * Lower 16 bits of the address.

3.2 Register Descriptions

3.2.1 Mode Control Register (MDCR)

Bit	:	7	6	5	4	3	2	1	0
		—	—	—	—	—	MDS2	MDS1	MDS0
Initial value:		1	0	0	0	0	—*	—*	—*
R/W	:	—	—	—	—	—	R	R	R

Note: * Determined by pins MD_2 to MD_0 .

MDCR is an 8-bit read-only register that indicates the current operating mode of the H8S/2355 Series.

Bit 7—Reserved: Read-only bit, always read as 1.

Bits 6 to 3—Reserved: Read-only bits, always read as 0.

Bits 2 to 0—Mode Select 2 to 0 (MDS2 to MDS0): These bits indicate the input levels at pins MD_2 to MD_0 (the current operating mode). Bits MDS2 to MDS0 correspond to MD_2 to MD_0 . MDS2 to MDS0 are read-only bits—they cannot be written to. The mode pin (MD_2 to MD_0) input levels are latched into these bits when MDCR is read. These latches are canceled by a power-on reset, but are retained after a manual reset.

3.2.2 System Control Register (SYSCR)

Bit	:	7	6	5	4	3	2	1	0
		—	—	INTM1	INTM0	NMIEG	—	—	RAME
Initial value:		0	0	0	0	0	0	0	1
R/W	:	R/W	—	R/W	R/W	R/W	—	R/W	R/W

Bit 7—Reserved: Only 0 should be written to this bit.

Bit 6—Reserved: Read-only bit, always read as 0.

Bits 5 and 4—Interrupt Control Mode 1 and 0 (INTM1, INTM0): These bits select the control mode of the interrupt controller. For details of the interrupt control modes, see section 5.4.1, Interrupt Control Modes and Interrupt Operation.

Bit 5	Bit 4	Interrupt Control Mode	Description
INTM1	INTM0		
0	0	0	Control of interrupts by I bit (Initial value)
	1	—	Setting prohibited
1	0	2	Control of interrupts by I2 to I0 bits and IPR
	1	—	Setting prohibited

Bit 3—NMI Edge Select (NMIEG): Selects the valid edge of the NMI interrupt input.

Bit 3

NMIEG	Description
0	An interrupt is requested at the falling edge of NMI input (Initial value)
1	An interrupt is requested at the rising edge of NMI input

Bit 2—Reserved: Read-only bit, always read as 0.

Bit 1—Reserved: Only 0 should be written to this bit.

Bit 0—RAM Enable (RAME): Enables or disables the on-chip RAM. The RAME bit is initialized when the reset status is released. It is not initialized in software standby mode.

Bit 0

RAME	Description
0	On-chip RAM is disabled
1	On-chip RAM is enabled (Initial value)

3.3 Operating Mode Descriptions

3.3.1 Mode 1

The CPU can access a 64-kbyte address space in normal mode. The on-chip ROM is disabled, and 8-bit bus mode is set, immediately after a reset.

Ports B and C function as an address bus, port D functions as a data bus, and part of port F carries bus control signals. However, note that if 16-bit access is designated by the bus controller, the bus mode switches to 16 bits and port E becomes a data bus.

3.3.2 Mode 2

The CPU can access a 64-kbyte address space in normal mode. The on-chip ROM is enabled, and 8-bit bus mode is set, immediately after a reset.

Ports B and C function as input ports immediately after a reset. They can each be set to output addresses by setting the corresponding bits in the data direction register (DDR) to 1. Port D functions as a data bus, and part of port F carries bus control signals. However, note that if 16-bit access is designated by the bus controller, the bus mode switches to 16 bits and port E becomes a data bus.

The amount of on-chip ROM that can be used is limited to 56 kbytes.

3.3.3 Mode 3

The CPU can access a 64-kbyte address space in normal mode. The on-chip ROM is enabled, but external addresses cannot be accessed.

All I/O ports are available for use as input-output ports.

The amount of on-chip ROM that can be used is limited to 56 kbytes.

3.3.4 Mode 4

The CPU can access a 16-Mbyte address space in advanced mode. The on-chip ROM is disabled.

Ports A, B and C function as an address bus, ports D and E function as a data bus, and part of port F carries bus control signals.

The initial bus mode after a reset is 16 bits, with 16-bit access to all areas. However, note that if 8-bit access is designated by the bus controller for all areas, the bus mode switches to 8 bits.

3.3.5 Mode 5

The CPU can access a 16-Mbyte address space in advanced mode. The on-chip ROM is disabled.

Ports A, B and C function as an address bus, ports D and E function as a data bus, and part of port F carries bus control signals.

The initial bus mode after a reset is 8 bits, with 8-bit access to all areas. However, note that if at least one area is designated for 16-bit access by the bus controller, the bus mode switches to 16 bits and port E becomes a data bus.

3.3.6 Mode 6

The CPU can access a 16-Mbyte address space in advanced mode. The on-chip ROM is enabled.

Ports A, B and C function as input ports immediately after a reset. They can each be set to output addresses by setting the corresponding bits in the data direction register (DDR) to 1. Port D functions as a data bus, and part of port F carries bus control signals.

The initial bus mode after a reset is 8 bits, with 8-bit access to all areas. However, note that if at least one area is designated for 16-bit access by the bus controller, the bus mode switches to 16 bits and port E becomes a data bus.

3.3.7 Mode 7

The CPU can access a 16-Mbyte address space in advanced mode. The on-chip ROM is enabled, but external addresses cannot be accessed.

All I/O ports are available for use as input-output ports.

3.4 Pin Functions in Each Operating Mode

The pin functions of ports A to F vary depending on the operating mode. Table 3-3 shows their functions in each operating mode.

Table 3-3 Pin Functions in Each Mode

Port		Mode 1	Mode 2	Mode 3	Mode 4	Mode 5	Mode 6	Mode 7
Port A	PA ₇ to PA ₅	P	P	P	P*/A	P*/A	P*/A	P
	PA ₄ to PA ₀				A	A		
Port B		A	P*/A	P	A	A	P*/A	P
Port C		A	P*/A	P	A	A	P*/A	P
Port D		D	D	P	D	D	D	P
Port E		P*/D	P*/D	P	P/D	P*/D	P*/D	P
Port F	PF ₇	P/C*	P/C*	P*/C	P/C*	P/C*	P/C*	P*/C
	PF ₆ to PF ₃	C	C	P	C	C	C	P
	PF ₂ to PF ₀	P*/C	P*/C		P*/C	P*/C	P*/C	

Legend

P: I/O port

A: Address bus output

D: Data bus I/O

C: Control signals, clock I/O

*: After reset

3.5 Memory Map in Each Operating Mode

A memory map of the H8S/2355 is shown in figure 3.1, a memory map of the H8S/2353 in figure 3.2, and a memory map of the H8S/2393 in figure 3.3.

The address space is 64 kbytes in modes 1 to 3 (normal modes), and 16 Mbytes in modes 4 to 7 (advanced modes).

The on-chip ROM capacity of the H8S/2355 is 128 kbytes, but only 56 kbytes are available in modes 2 and 3 (normal modes).

The address space is divided into eight areas for modes 4 to 7. For details, see section 6, Bus Controller.

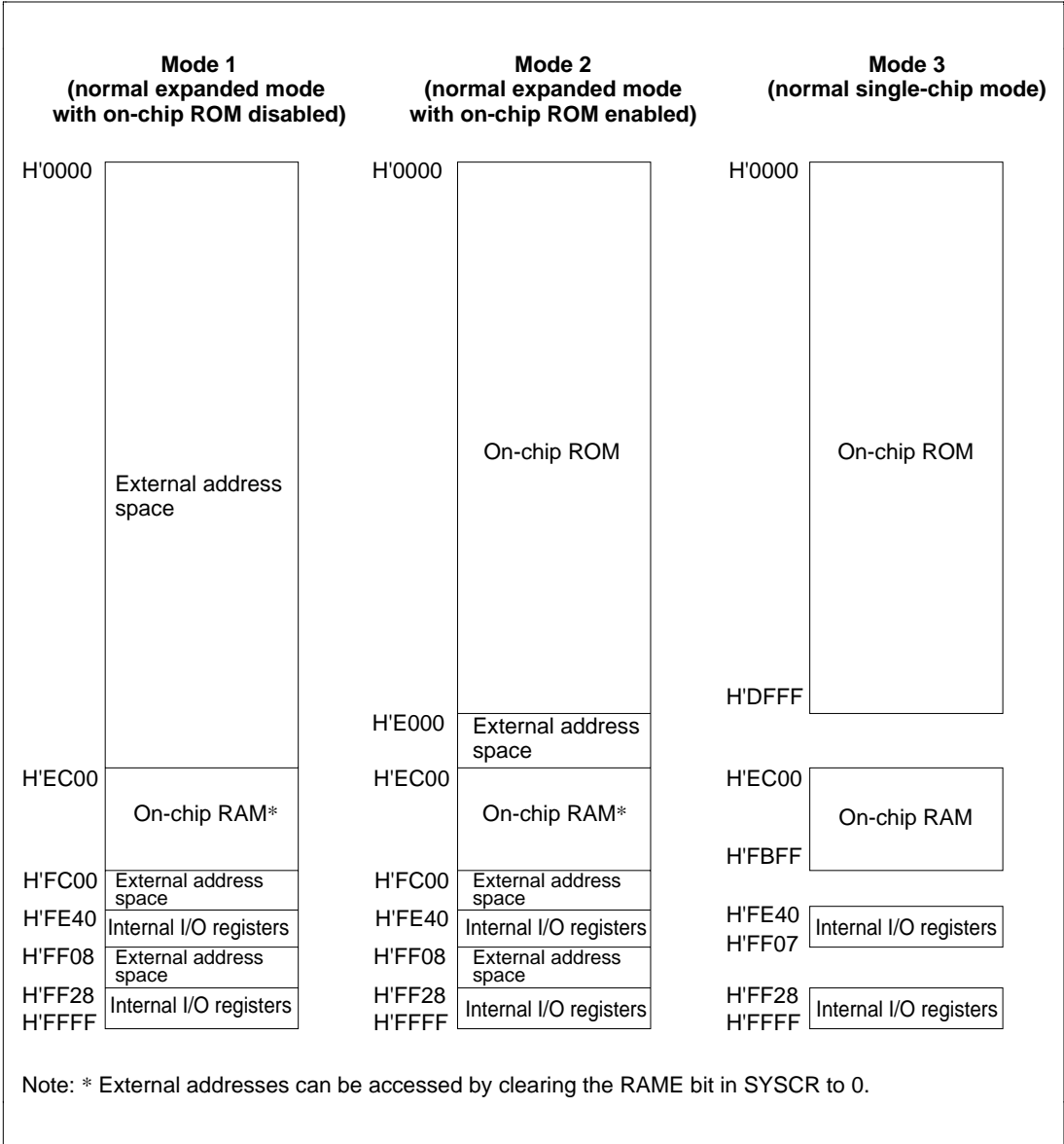

Figure 3-1 Memory Map in Each Operating Mode in the H8S/2355

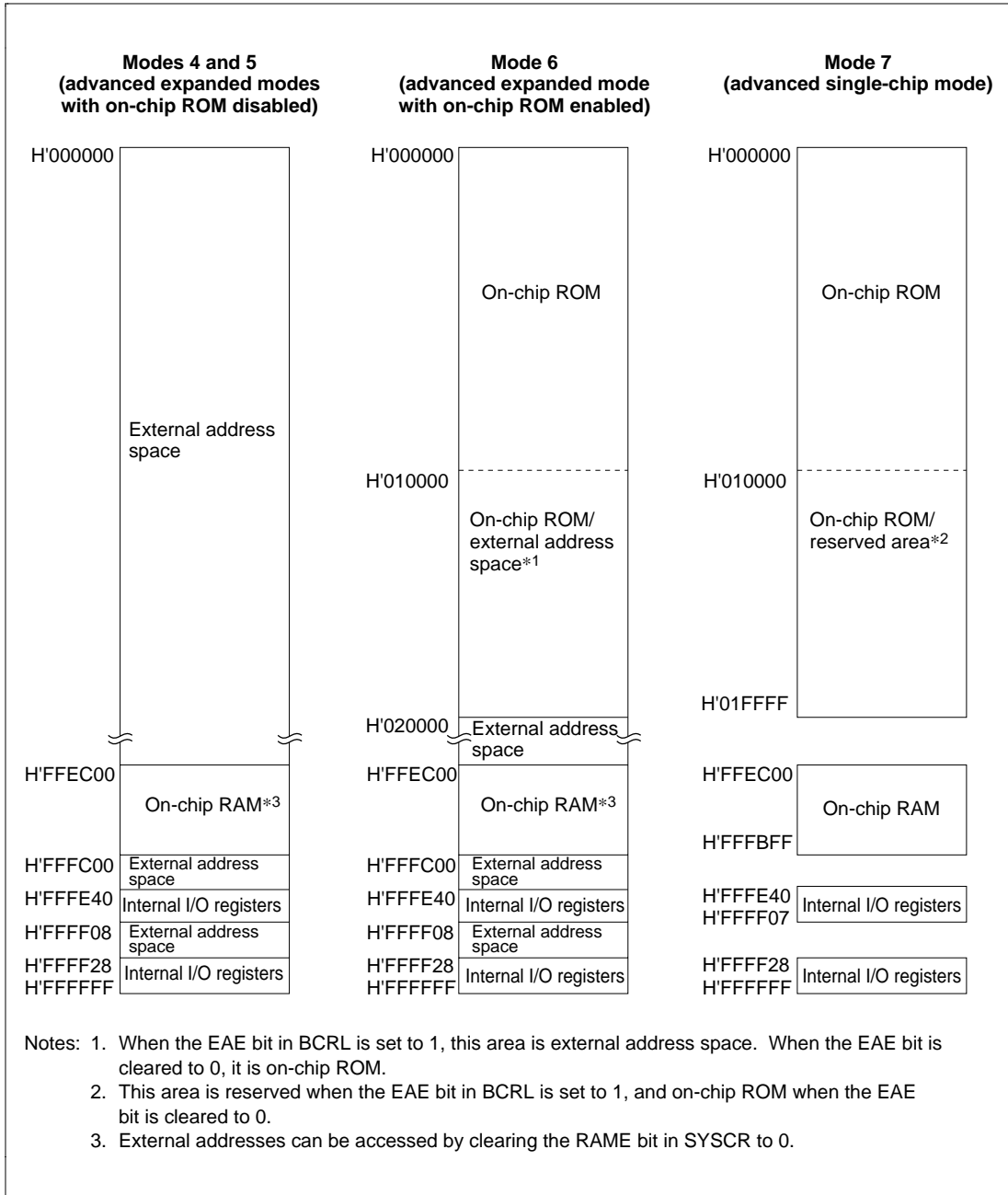

Figure 3-1 Memory Map in Each Operating Mode in the H8S/2355 (cont)

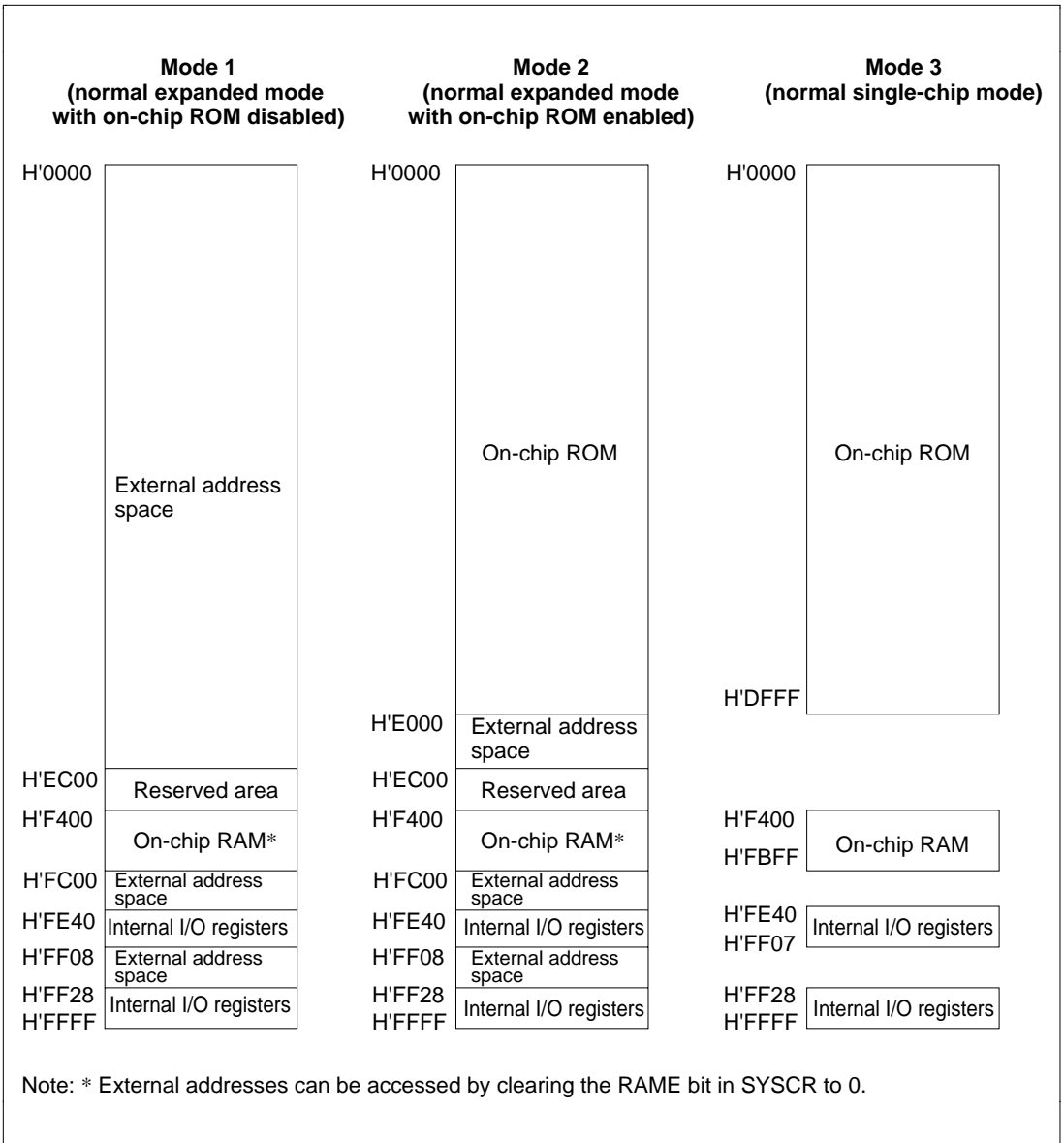

Figure 3-2 Memory Map in Each Operating Mode in the H8S/2353

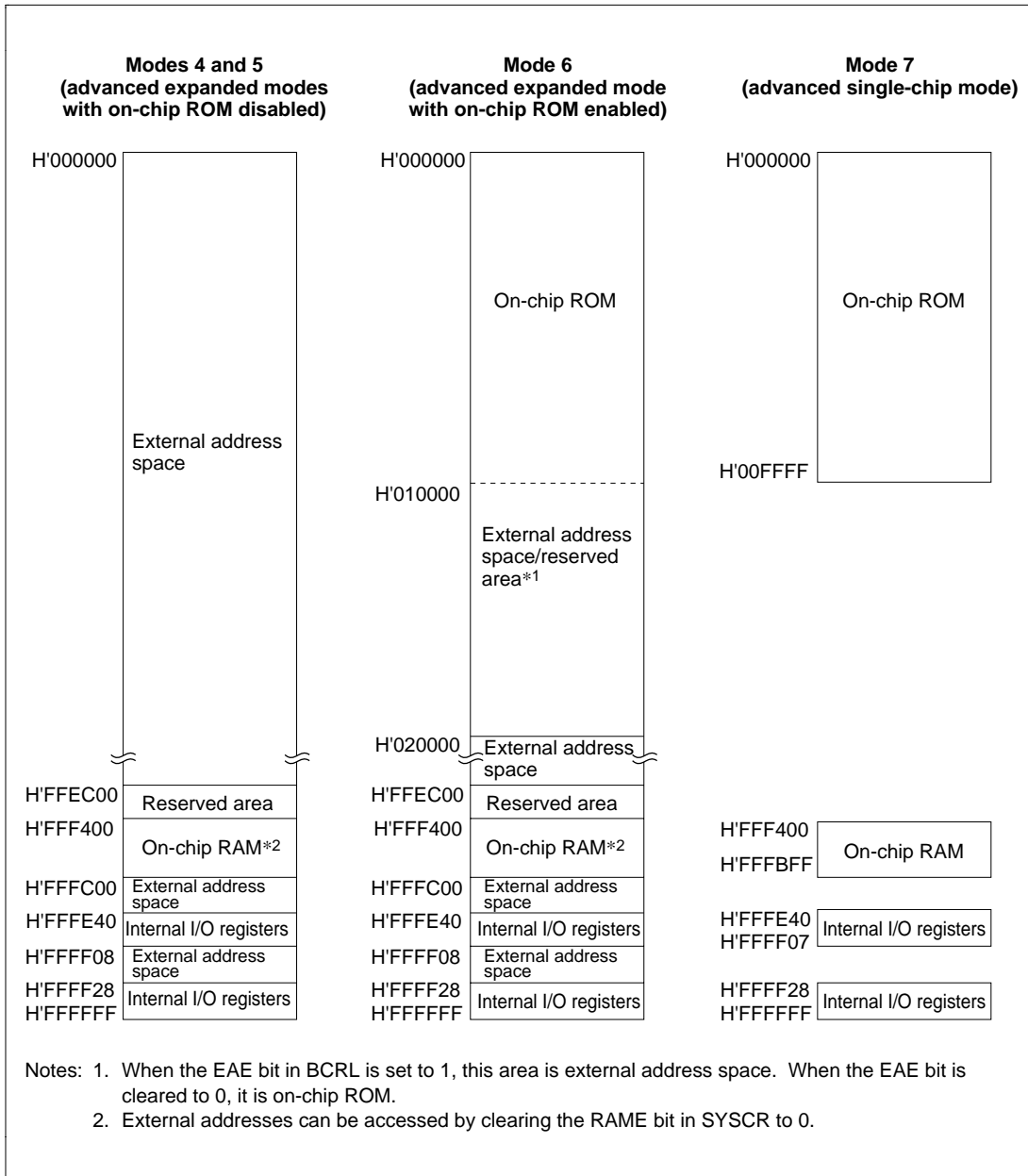
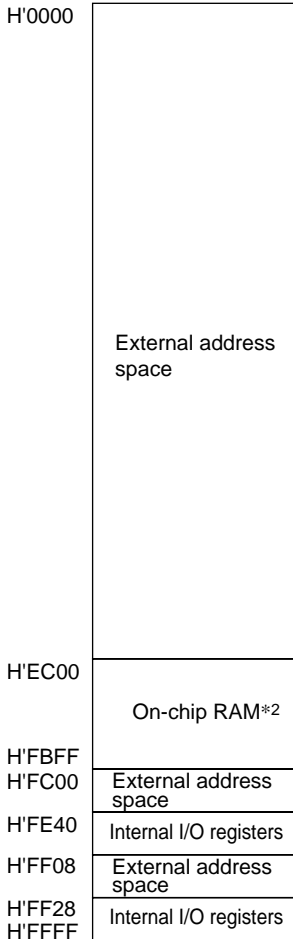
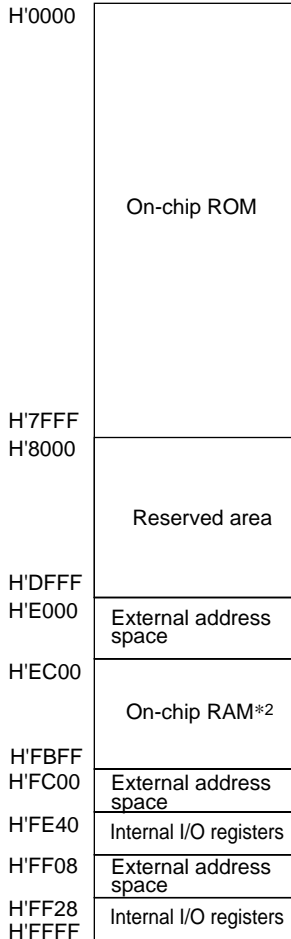

Figure 3-2 Memory Map in Each Operating Mode in the H8S/2353 (cont)

Mode 1
(normal expanded mode
with on-chip ROM disabled)



Mode 2
(normal expanded mode
with on-chip ROM enabled)



Mode 3
(normal single-chip mode)

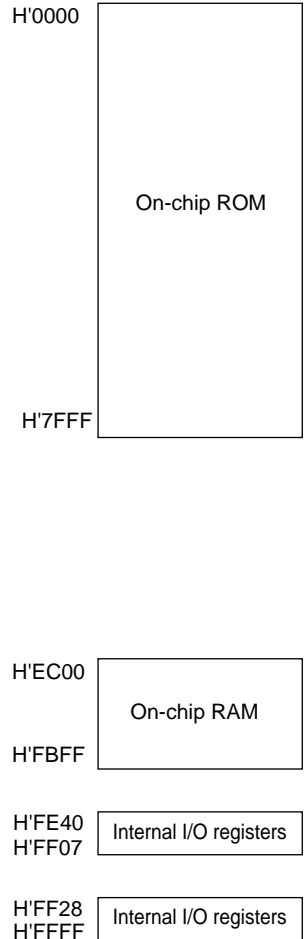

- Notes: 1. When the EAE bit in BCRL is set to 1, this area is external address space. When the EAE bit is cleared to 0, it is on-chip ROM.
2. External addresses can be accessed by clearing the RAME bit in SYSCR to 0.

Figure 3-3 Memory Map in Each Operating Mode in the H8S/2393

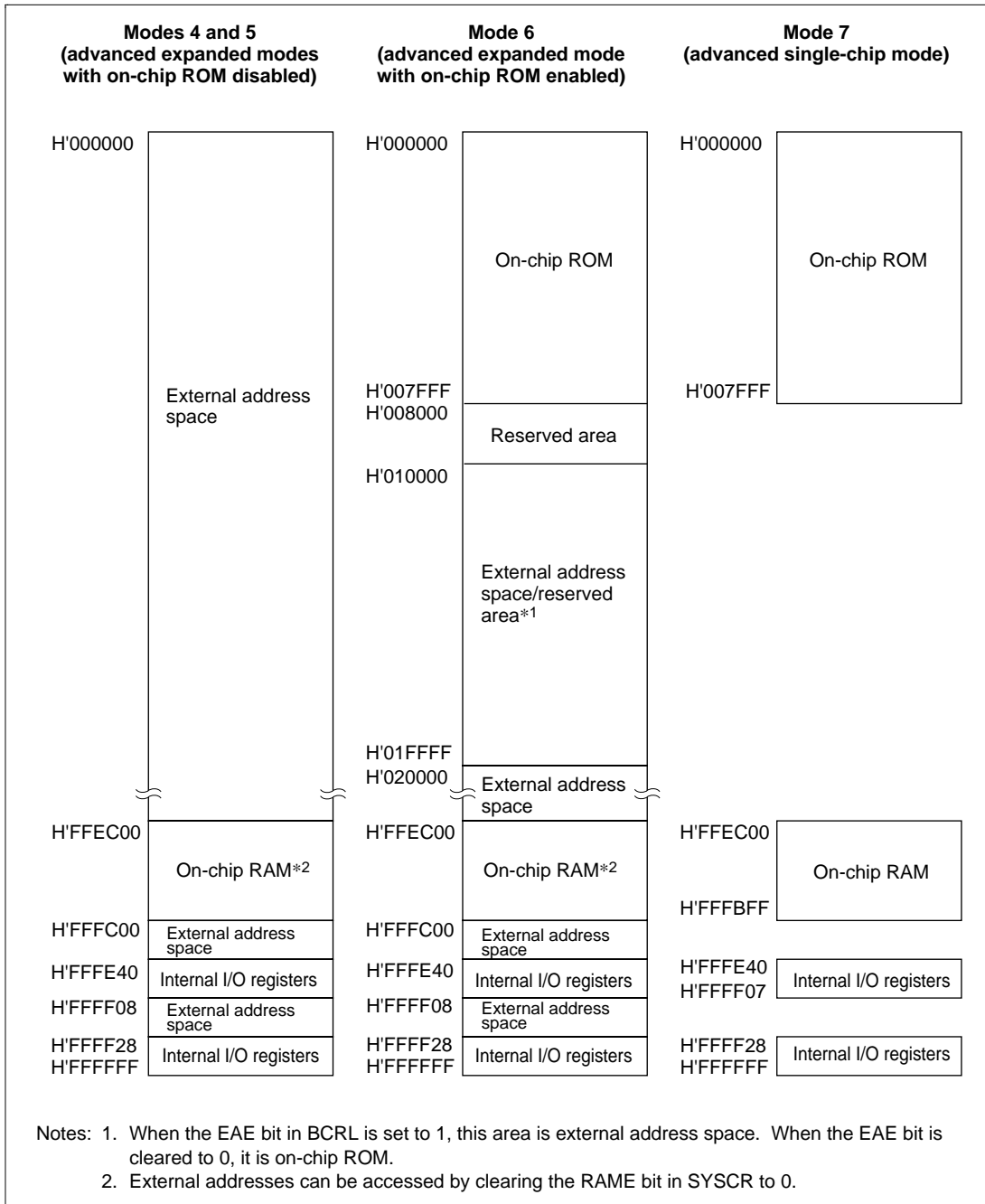

Figure 3-3 Memory Map in Each Operating Mode in the H8S/2393

Section 4 Exception Handling

4.1 Overview

4.1.1 Exception Handling Types and Priority

As table 4-1 indicates, exception handling may be caused by a reset, trap instruction, or interrupt. Exception handling is prioritized as shown in table 4-1. If two or more exceptions occur simultaneously, they are accepted and processed in order of priority. Trap instruction exceptions are accepted at all times, in the program execution state.

Exception handling sources, the stack structure, and the operation of the CPU vary depending on the interrupt control mode set by the INTM0 and INTM1 bits of SYSCR.

Table 4-1 Exception Types and Priority

Priority	Exception Type	Start of Exception Handling
High ↑	Reset	Starts immediately after a low-to-high transition at the \overline{RES} pin, or when the watchdog timer overflows. The CPU enters the power-on reset state when the NMI pin is high, or the manual reset state when the NMI pin is low.
	Trace* ¹	Starts when execution of the current instruction or exception handling ends, if the trace (T) bit is set to 1
	Interrupt	Starts when execution of the current instruction or exception handling ends, if an interrupt request has been issued* ²
Low	Trap instruction (TRAPA)* ³	Started by execution of a trap instruction (TRAPA)

- Notes:
1. Traces are enabled only in interrupt control mode
 2. Trace exception handling is not executed after execution of an RTE instruction.
 3. Interrupt detection is not performed on completion of ANDC, ORC, XORC, or LDC instruction execution, or on completion of reset exception handling.
 3. Trap instruction exception handling requests are accepted at all times in program execution state.

4.1.2 Exception Handling Operation

Exceptions originate from various sources. Trap instructions and interrupts are handled as follows:

1. The program counter (PC), condition code register (CCR), and extended register (EXR) are pushed onto the stack.
2. The interrupt mask bits are updated. The T bit is cleared to 0.
3. A vector address corresponding to the exception source is generated, and program execution starts from that address.

For a reset exception, steps 2 and 3 above are carried out.

4.1.3 Exception Vector Table

The exception sources are classified as shown in figure 4-1. Different vector addresses are assigned to different exception sources.

Table 4-2 lists the exception sources and their vector addresses.

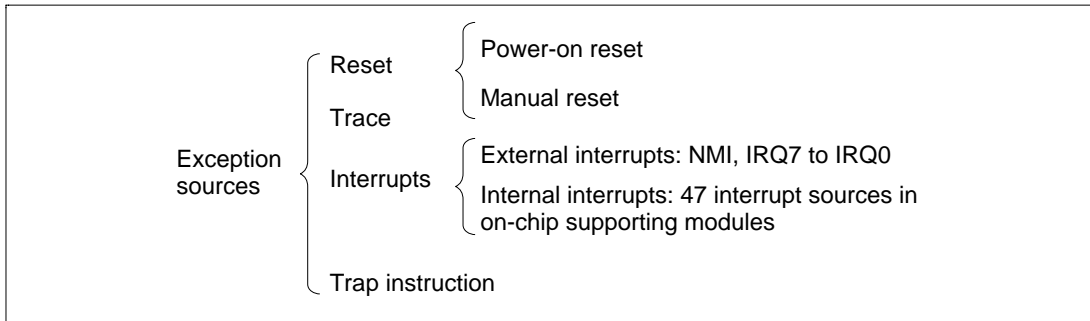

Figure 4-1 Exception Sources

In modes 6 and 7 in the H8S/2355, the on-chip ROM available for use after a power-on reset is the 64-kbyte area comprising addresses H'000000 to H'00FFFF. Care is required when setting vector addresses. In this case, clearing the EAE bit in BCRL enables the 128-kbyte area comprising addresses H'000000 to H'01FFFF to be used.

Table 4-2 Exception Vector Table

Exception Source	Vector Number	Vector Address* ¹		
		Normal Mode	Advanced Mode	
Power-on reset	0	H'0000 to H'0001	H'0000 to H'0003	
Manual reset	1	H'0002 to H'0003	H'0004 to H'0007	
Reserved for system use	2	H'0004 to H'0006	H'0008 to H'000B	
	3	H'0006 to H'0007	H'000C to H'000F	
	4	H'0008 to H'0009	H'0010 to H'0013	
Trace	5	H'000A to H'000B	H'0014 to H'0017	
Reserved for system use	6	H'000C to H'000D	H'0018 to H'001B	
External interrupt NMI	7	H'000E to H'000F	H'001C to H'001F	
Trap instruction (4 sources)	8	H'0010 to H'0011	H'0020 to H'0023	
	9	H'0012 to H'0013	H'0024 to H'0027	
	10	H'0014 to H'0015	H'0028 to H'002B	
	11	H'0016 to H'0017	H'002C to H'002F	
Reserved for system use	12	H'0018 to H'0019	H'0030 to H'0033	
	13	H'001A to H'001B	H'0034 to H'0037	
	14	H'001C to H'001D	H'0038 to H'003B	
	15	H'001E to H'001F	H'003C to H'003F	
External interrupt	IRQ0	16	H'0020 to H'0021	H'0040 to H'0043
	IRQ1	17	H'0022 to H'0023	H'0044 to H'0047
	IRQ2	18	H'0024 to H'0025	H'0048 to H'004B
	IRQ3	19	H'0026 to H'0027	H'004C to H'004F
	IRQ4	20	H'0028 to H'0029	H'0050 to H'0053
	IRQ5	21	H'002A to H'002B	H'0054 to H'0057
	IRQ6	22	H'002C to H'002D	H'0058 to H'005B
	IRQ7	23	H'002E to H'002F	H'005C to H'005F
Internal interrupt* ²	24		H'0030 to H'0031	H'0060 to H'0063
	91		H'00B6 to H'00B7	H'016C to H'016F

Notes: 1. Lower 16 bits of the address.

2. For details of internal interrupt vectors, see section 5.3.3, Interrupt Exception Handling Vector Table.

4.2 Reset

4.2.1 Overview

A reset has the highest exception priority.

When the $\overline{\text{RES}}$ pin goes low, all processing halts and the H8S/2355 Series enters the reset state. A reset initializes the internal state of the CPU and the registers of on-chip supporting modules. Immediately after a reset, interrupt control mode 0 is set.

Reset exception handling begins when the $\overline{\text{RES}}$ pin changes from low to high.

The level of the NMI pin at reset determines whether the type of reset is a power-on reset or a manual reset.

The H8S/2355 Series can also be reset by overflow of the watchdog timer. For details see section 11, Watchdog Timer.

4.2.2 Reset Types

A reset can be of either of two types: a power-on reset or a manual reset. Reset types are shown in table 4-3. A power-on reset should be used when powering on.

The internal state of the CPU is initialized by either type of reset. A power-on reset also initializes all the registers in the on-chip supporting modules, while a manual reset initializes all the registers in the on-chip supporting modules except for the bus controller and I/O ports, which retain their previous states.

With a manual reset, since the on-chip supporting modules are initialized, ports used as on-chip supporting module I/O pins are switched to I/O ports controlled by DDR and DR.

Table 4-3 Reset Types

Type	Reset Transition Conditions		Internal State	
	NMI	$\overline{\text{RES}}$	CPU	On-Chip Supporting Modules
Power-on reset	High	Low	Initialized	Initialized
Manual reset	Low	Low	Initialized	Initialized, except for bus controller and I/O ports

A reset caused by the watchdog timer can also be of either of two types: a power-on reset or a manual reset.

4.2.3 Reset Sequence

The H8S/2355 Series enters the reset state when the $\overline{\text{RES}}$ pin goes low.

To ensure that the H8S/2355 Series is reset, hold the $\overline{\text{RES}}$ pin low for at least 20 ms at power-up. To reset the H8S/2355 Series during operation, hold the $\overline{\text{RES}}$ pin low for at least 20 states.

When the $\overline{\text{RES}}$ pin goes high after being held low for the necessary time, the H8S/2355 Series starts reset exception handling as follows:

1. The internal state of the CPU and the registers of the on-chip supporting modules are initialized, the T bit is cleared to 0 in EXR, and the I bit is set to 1 in EXR and CCR.
2. The reset exception handling vector address is read and transferred to the PC, and program execution starts from the address indicated by the PC.

Figures 4-2 and 4-3 show examples of the reset sequence.

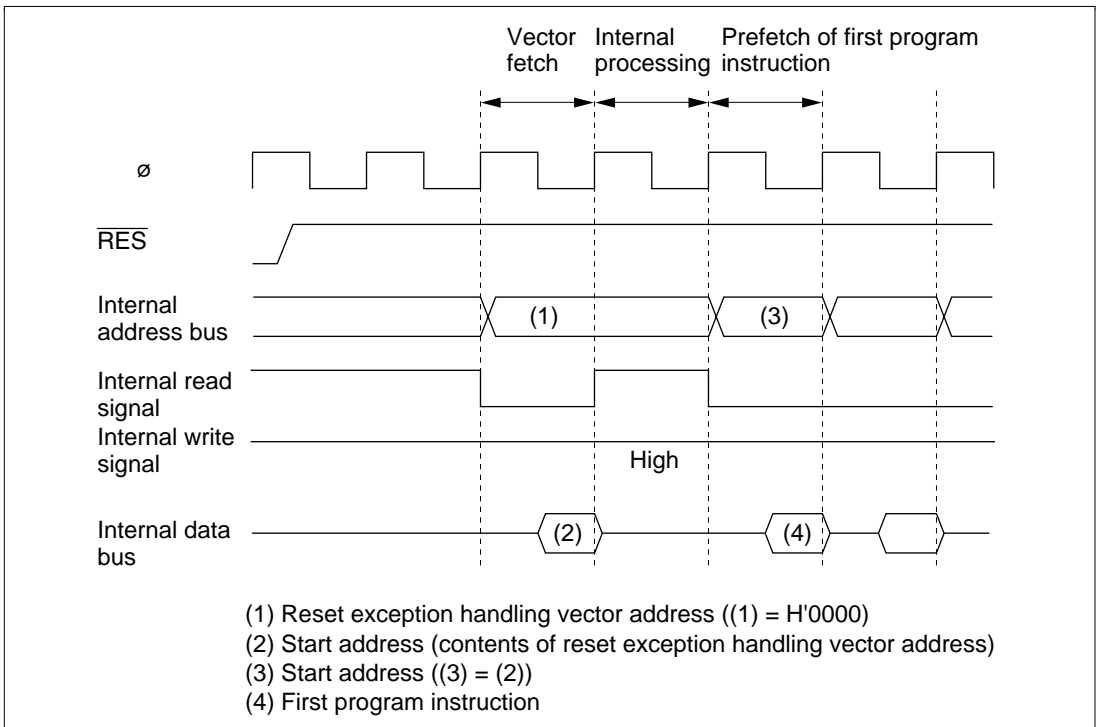
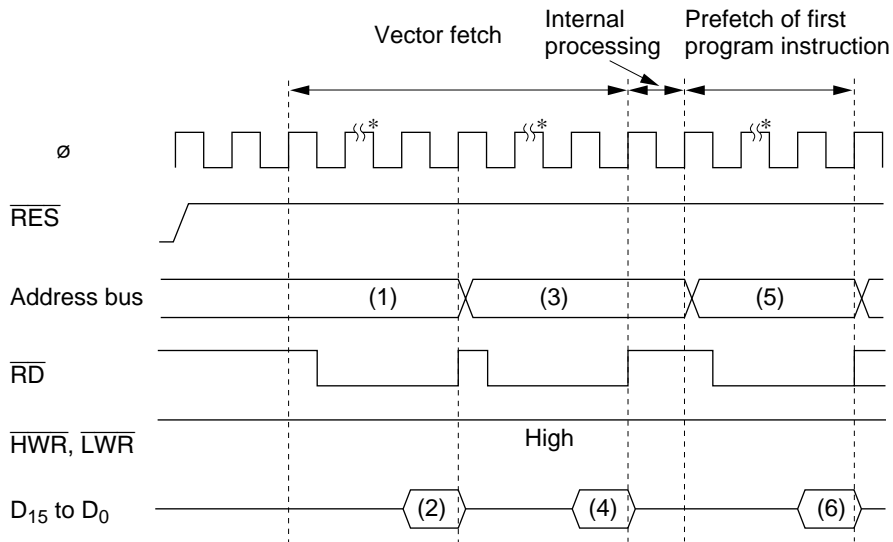

Figure 4-2 Reset Sequence (Modes 2 and 3)



- (1) (3) Reset exception handling vector address ((1) = H'000000, (3) = H'000002)
 (2) (4) Start address (contents of reset exception handling vector address)
 (5) Start address ((5) = (2) (4))
 (6) First program instruction

Note: * 3 program wait states are inserted.

Figure 4-3 Reset Sequence (Mode 4)

4.2.4 Interrupts after Reset

If an interrupt is accepted after a reset but before the stack pointer (SP) is initialized, the PC and CCR will not be saved correctly, leading to a program crash. To prevent this, all interrupt requests, including NMI, are disabled immediately after a reset. Since the first instruction of a program is always executed immediately after the reset state ends, make sure that this instruction initializes the stack pointer (example: MOV.L #xx: 32, SP).

4.2.5 State of On-Chip Supporting Modules after Reset Release

After reset release, MSTPCR is initialized to H'3FFF and all modules except the DTC enter module stop mode. Consequently, on-chip supporting module registers cannot be read or written to. Register reading and writing is enabled when module stop mode is exited.

4.3 Traces

Traces are enabled in interrupt control mode 2. Trace mode is not activated in interrupt control mode 0, irrespective of the state of the T bit. For details of interrupt control modes, see section 5, Interrupt Controller.

If the T bit in EXR is set to 1, trace mode is activated. In trace mode, a trace exception occurs on completion of each instruction.

Trace mode is canceled by clearing the T bit in EXR to 0. It is not affected by interrupt masking.

Table 4-4 shows the state of CCR and EXR after execution of trace exception handling.

Interrupts are accepted even within the trace exception handling routine.

The T bit saved on the stack retains its value of 1, and when control is returned from the trace exception handling routine by the RTE instruction, trace mode resumes.

Trace exception handling is not carried out after execution of the RTE instruction.

Table 4-4 Status of CCR and EXR after Trace Exception Handling

Interrupt Control Mode	CCR		EXR	
	I	UI	I2 to I0	T
0	Trace exception handling cannot be used.			
2	1	—	—	0

Legend

1: Set to 1

0: Cleared to 0

—: Retains value prior to execution.

4.4 Interrupts

Interrupt exception handling can be requested by nine external sources (NMI, IRQ7 to IRQ0) and 47 internal sources in the on-chip supporting modules. Figure 4-4 classifies the interrupt sources and the number of interrupts of each type.

The on-chip supporting modules that can request interrupts include the watchdog timer (WDT), 16-bit timer-pulse unit (TPU), 8-bit timer, serial communication interface (SCI), data transfer controller (DTC), and A/D converter. Each interrupt source has a separate vector address.

NMI is the highest-priority interrupt. Interrupts are controlled by the interrupt controller. The interrupt controller has two interrupt control modes and can assign interrupts other than NMI to eight priority/mask levels to enable multiplexed interrupt control.

For details of interrupts, see section 5, Interrupt Controller.

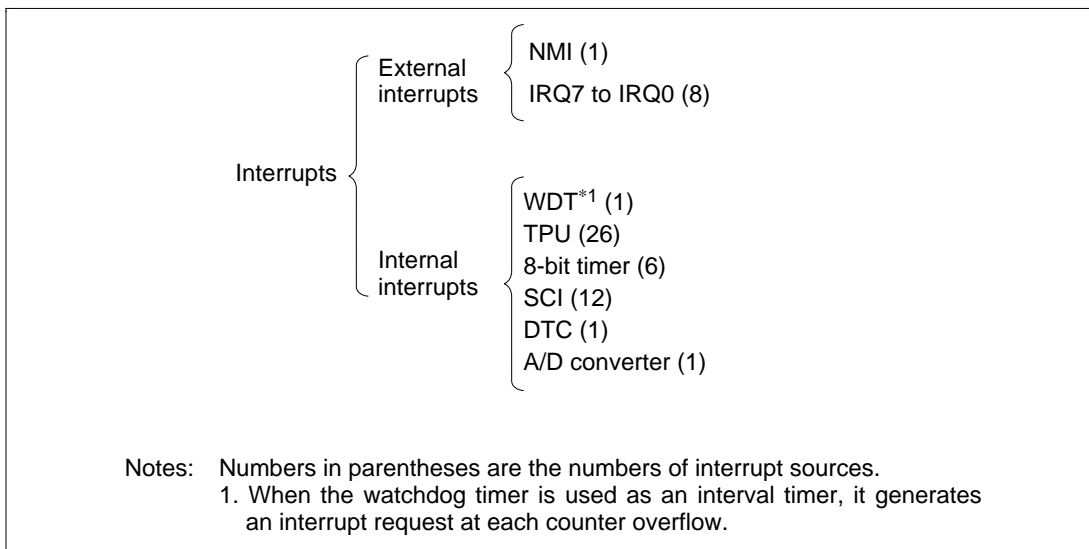

Figure 4-4 Interrupt Sources and Number of Interrupts

4.5 Trap Instruction

Trap instruction exception handling starts when a TRAPA instruction is executed. Trap instruction exception handling can be executed at all times in the program execution state.

The TRAPA instruction fetches a start address from a vector table entry corresponding to a vector number from 0 to 3, as specified in the instruction code.

Table 4-5 shows the status of CCR and EXR after execution of trap instruction exception handling.

Table 4-5 Status of CCR and EXR after Trap Instruction Exception Handling

Interrupt Control Mode	CCR		EXR	
	I	UI	I2 to I0	T
0	1	—	—	—
2	1	—	—	0

Legend

1: Set to 1

0: Cleared to 0

—: Retains value prior to execution.

4.6 Stack Status after Exception Handling

Figure 4-5 shows the stack after completion of trap instruction exception handling and interrupt exception handling.

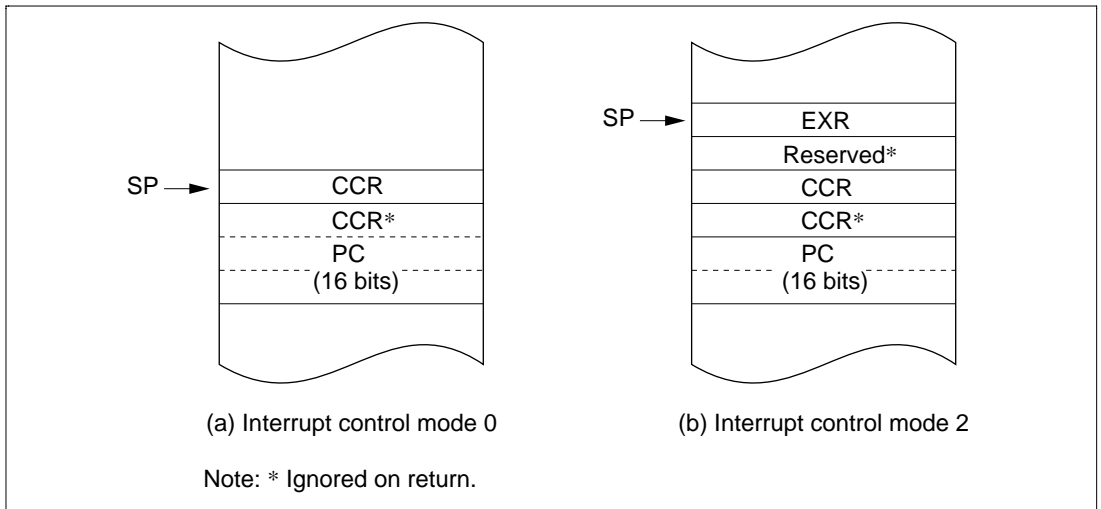

Figure 4-5 (1) Stack Status after Exception Handling (Normal Modes)

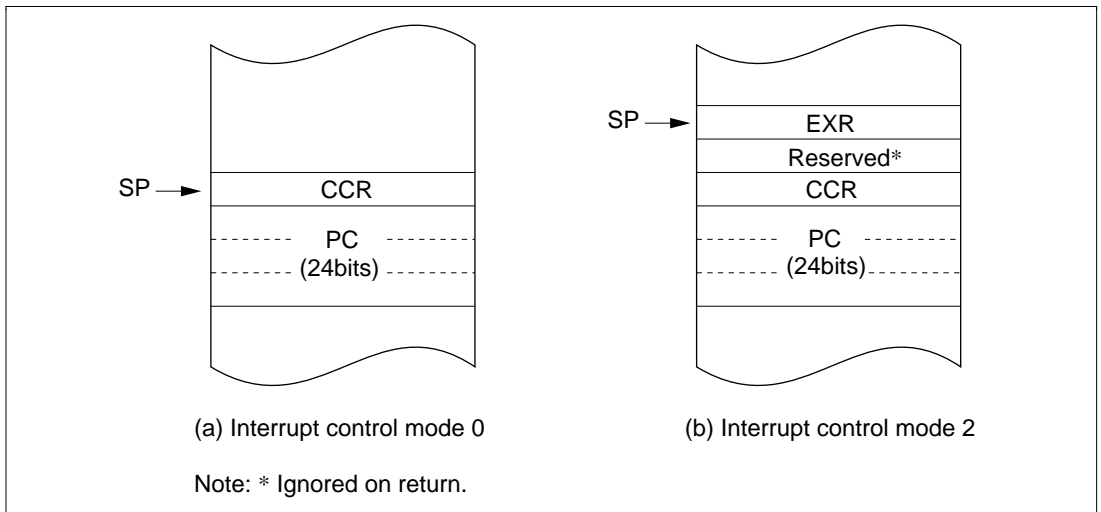

Figure 4-5 (2) Stack Status after Exception Handling (Advanced Modes)

4.7 Notes on Use of the Stack

When accessing word data or longword data, the H8S/2355 Series assumes that the lowest address bit is 0. The stack should always be accessed by word transfer instruction or longword transfer instruction, and the value of the stack pointer (SP, ER7) should always be kept even. Use the following instructions to save registers:

PUSH.W Rn (or MOV.W Rn, @-SP)

PUSH.L ERn (or MOV.L ERn, @-SP)

Use the following instructions to restore registers:

POP.W Rn (or MOV.W @SP+, Rn)

POP.L ERn (or MOV.L @SP+, ERn)

Setting SP to an odd value may lead to a malfunction. Figure 4-6 shows an example of what happens when the SP value is odd.

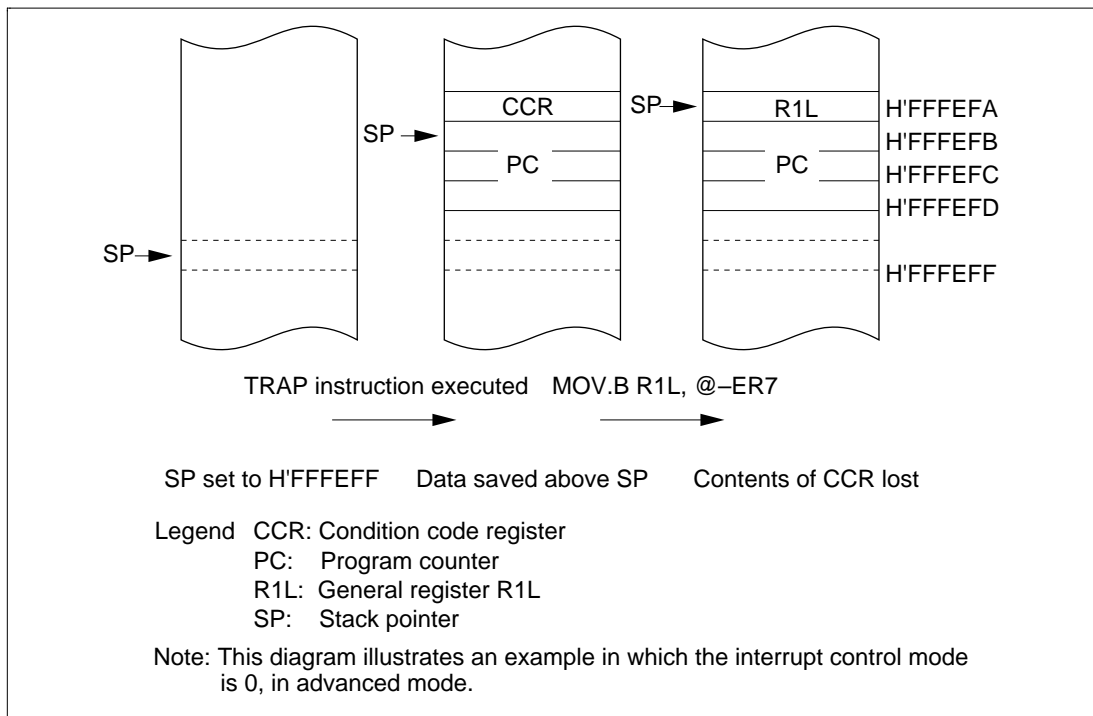

Figure 4-6 Operation when SP Value is Odd

Section 5 Interrupt Controller

5.1 Overview

5.1.1 Features

The H8S/2355 Series controls interrupts by means of an interrupt controller. The interrupt controller has the following features:

- Two interrupt control modes
 - Any of two interrupt control modes can be set by means of the INTM1 and INTM0 bits in the system control register (SYSCR).
- Priorities settable with IPR
 - An interrupt priority register (IPR) is provided for setting interrupt priorities. Eight priority levels can be set for each module for all interrupts except NMI.
 - NMI is assigned the highest priority level of 8, and can be accepted at all times.
- Independent vector addresses
 - All interrupt sources are assigned independent vector addresses, making it unnecessary for the source to be identified in the interrupt handling routine.
- Nine external interrupts
 - NMI is the highest-priority interrupt, and is accepted at all times. Rising edge or falling edge can be selected for NMI.
 - Falling edge, rising edge, or both edge detection, or level sensing, can be selected for IRQ7 to IRQ0.
- DTC control
 - DTC activation is performed by means of interrupts.

5.1.2 Block Diagram

A block diagram of the interrupt controller is shown in Figure 5-1.

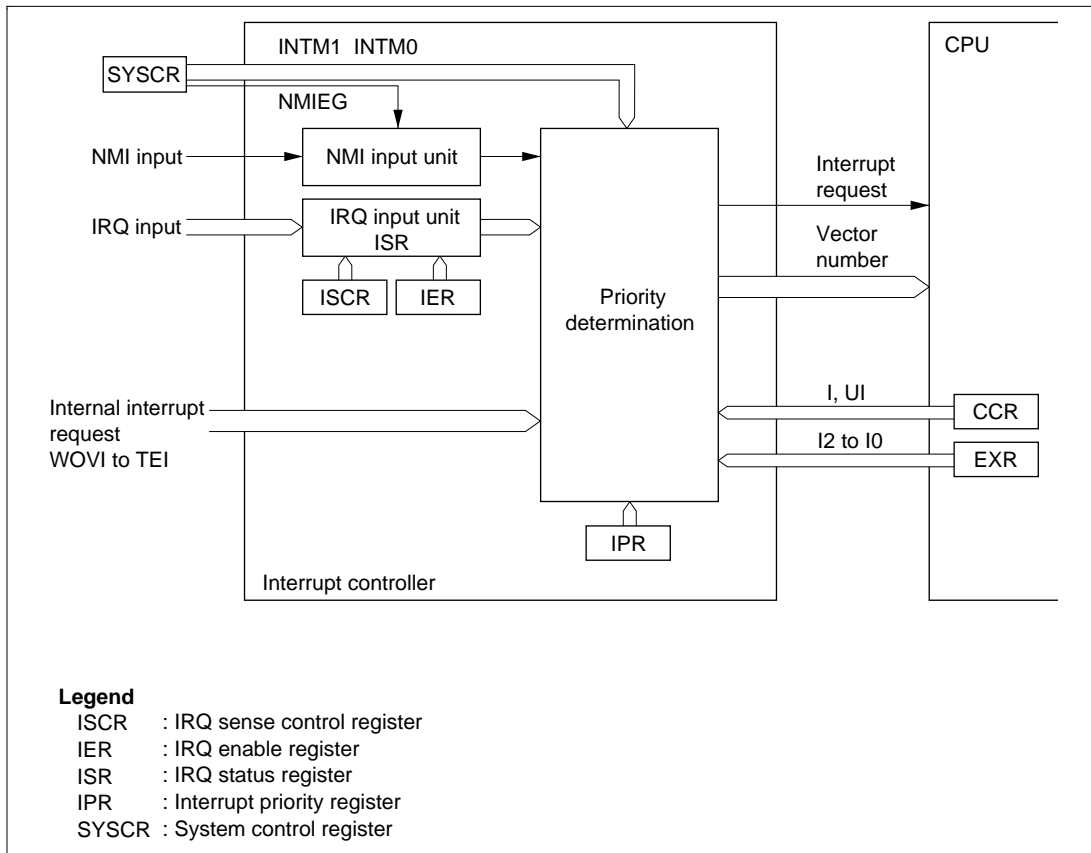

Figure 5-1 Block Diagram of Interrupt Controller

5.1.3 Pin Configuration

Table 5-1 summarizes the pins of the interrupt controller.

Table 5-1 Interrupt Controller Pins

Name	Symbol	I/O	Function
Nonmaskable interrupt	NMI	Input	Nonmaskable external interrupt; rising or falling edge can be selected
External interrupt requests 7 to 0	$\overline{\text{IRQ7}}$ to $\overline{\text{IRQ0}}$	Input	Maskable external interrupts; rising, falling, or both edges, or level sensing, can be selected

5.1.4 Register Configuration

Table 5-2 summarizes the registers of the interrupt controller.

Table 5-2 Interrupt Controller Registers

Name	Abbreviation	R/W	Initial Value	Address* ¹
System control register	SYSCR	R/W	H'01	H'FF39
IRQ sense control register H	ISCRH	R/W	H'00	H'FF2C
IRQ sense control register L	ISCR L	R/W	H'00	H'FF2D
IRQ enable register	IER	R/W	H'00	H'FF2E
IRQ status register	ISR	R/(W)* ²	H'00	H'FF2F
Interrupt priority register A	IPRA	R/W	H'77	H'FEC4
Interrupt priority register B	IPRB	R/W	H'77	H'FEC5
Interrupt priority register C	IPRC	R/W	H'77	H'FEC6
Interrupt priority register D	IPRD	R/W	H'77	H'FEC7
Interrupt priority register E	IPRE	R/W	H'77	H'FEC8
Interrupt priority register F	IPRF	R/W	H'77	H'FEC9
Interrupt priority register G	IPRG	R/W	H'77	H'FECA
Interrupt priority register H	IPRH	R/W	H'77	H'FECB
Interrupt priority register I	IPRI	R/W	H'77	H'FECC
Interrupt priority register J	IPRJ	R/W	H'77	H'FECD
Interrupt priority register K	IPRK	R/W	H'77	H'FECE

Notes: 1. Lower 16 bits of the address.

2. Can only be written with 0 for flag clearing.

5.2 Register Descriptions

5.2.1 System Control Register (SYSCR)

Bit	:	7	6	5	4	3	2	1	0
		—	—	INTM1	INTM0	NMIEG	—	—	RAME
Initial value:		0	0	0	0	0	0	0	1
R/W	:	R/W	—	R/W	R/W	R/W	—	R/W	R/W

SYSCR is an 8-bit readable/writable register that selects the interrupt control mode, and the detected edge for NMI.

Only bits 5 to 3 are described here; for details of the other bits, see section 3.2.2, System Control Register (SYSCR).

SYSCR is initialized to H'01 by a reset and in hardware standby mode. It is not initialized in software standby mode.

Bits 5 and 4—Interrupt Control Mode 1 and 0 (INTM1, INTM0): These bits select one of two interrupt control modes for the interrupt controller.

Bit 5	Bit 4	Interrupt	
INTM1	INTM0	Control Mode	Description
0	0	0	Interrupts are controlled by I bit (Initial value)
	1	—	Setting prohibited
1	0	2	Interrupts are controlled by bits I2 to I0, and IPR
	1	—	Setting prohibited

Bit 3—NMI Edge Select (NMIEG): Selects the input edge for the NMI pin.

Bit 3	
NMIEG	Description
0	Interrupt request generated at falling edge of NMI input (Initial value)
1	Interrupt request generated at rising edge of NMI input

5.2.2 Interrupt Priority Registers A to K (IPRA to IPRK)

Bit	:	7	6	5	4	3	2	1	0
		—	IPR6	IPR5	IPR4	—	IPR2	IPR1	IPR0
Initial value:		0	1	1	1	0	1	1	1
R/W	:	—	R/W	R/W	R/W	—	R/W	R/W	R/W

The IPR registers are eleven 8-bit readable/writable registers that set priorities (levels 7 to 0) for interrupts other than NMI.

The correspondence between IPR settings and interrupt sources is shown in table 5-3.

The IPR registers set a priority (level 7 to 0) for each interrupt source other than NMI.

The IPR registers are initialized to H'77 by a reset and in hardware standby mode.

Bits 7 and 3—Reserved: Read-only bits, always read as 0.

Table 5-3 Correspondence between Interrupt Sources and IPR Settings

Register	Bits	
	6 to 4	2 to 0
IPRA	IRQ0	IRQ1
IPRB	IRQ2 IRQ3	IRQ4 IRQ5
IPRC	IRQ6 IRQ7	DTC
IPRD	Watchdog timer	—*
IPRE	—*	A/D converter
IPRF	TPU channel 0	TPU channel 1
IPRG	TPU channel 2	TPU channel 3
IPRH	TPU channel 4	TPU channel 5
IPRI	8-bit timer channel 0	8-bit timer channel 1
IPRJ	—*	SCI channel 0
IPRK	SCI channel 1	SCI channel 2

Note: * Reserved bits. These bits cannot be modified and are always read as 1.

As shown in table 5-3, multiple interrupts are assigned to one IPR. Setting a value in the range from H'0 to H'7 in the 3-bit groups of bits 6 to 4 and 2 to 0 sets the priority of the corresponding interrupt. The lowest priority level, level 0, is assigned by setting H'0, and the highest priority level, level 7, by setting H'7.

When interrupt requests are generated, the highest-priority interrupt according to the priority levels set in the IPR registers is selected. This interrupt level is then compared with the interrupt mask level set by the interrupt mask bits (I2 to I0) in the extend register (EXR) in the CPU, and if the priority level of the interrupt is higher than the set mask level, an interrupt request is issued to the CPU.

5.2.3 IRQ Enable Register (IER)

IER is an 8-bit readable/writable register that controls enabling and disabling of interrupt requests IRQ7 to IRQ0.

Bit	:	7	6	5	4	3	2	1	0
		IRQ7E	IRQ6E	IRQ5E	IRQ4E	IRQ3E	IRQ2E	IRQ1E	IRQ0E
Initial value:		0	0	0	0	0	0	0	0
R/W	:	R/W	R/W	R/W	R/W	R/W	R/W	R/W	R/W

IER is initialized to H'00 by a reset and in hardware standby mode.

Bits 7 to 0—IRQ7 to IRQ0 Enable (IRQ7E to IRQ0E): These bits select whether IRQ7 to IRQ0 are enabled or disabled.

Bit n

IRQnE	Description
0	IRQn interrupts disabled (Initial value)
1	IRQn interrupts enabled

(n = 7 to 0)

5.2.4 IRQ Sense Control Registers H and L (ISCRH, ISCR L)

ISCRH

Bit	:	15	14	13	12	11	10	9	8
		IRQ7SCB	IRQ7SCA	IRQ6SCB	IRQ6SCA	IRQ5SCB	IRQ5SCA	IRQ4SCB	IRQ4SCA
Initial value:		0	0	0	0	0	0	0	0
R/W	:	R/W	R/W	R/W	R/W	R/W	R/W	R/W	R/W

ISCR L

Bit	:	7	6	5	4	3	2	1	0
		IRQ3SCB	IRQ3SCA	IRQ2SCB	IRQ2SCA	IRQ1SCB	IRQ1SCA	IRQ0SCB	IRQ0SCA
Initial value:		0	0	0	0	0	0	0	0
R/W	:	R/W	R/W	R/W	R/W	R/W	R/W	R/W	R/W

The ISCR registers are 16-bit readable/writable registers that select rising edge, falling edge, or both edge detection, or level sensing, for the input at pins $\overline{\text{IRQ7}}$ to $\overline{\text{IRQ0}}$.

The ISCR registers are initialized to H'0000 by a reset and in hardware standby mode.

Bits 15 to 0: IRQ7 Sense Control A and B (IRQ7SCA, IRQ7SCB) to IRQ0 Sense Control A and B (IRQ0SCA, IRQ0SCB)

Bits 15 to 0

IRQ7SCB to IRQ0SCB	IRQ7SCA to IRQ0SCA	Description
0	0	Interrupt request generated at $\overline{\text{IRQ7}}$ to $\overline{\text{IRQ0}}$ input low level (initial value)
	1	Interrupt request generated at falling edge of $\overline{\text{IRQ7}}$ to $\overline{\text{IRQ0}}$ input
1	0	Interrupt request generated at rising edge of $\overline{\text{IRQ7}}$ to $\overline{\text{IRQ0}}$ input
	1	Interrupt request generated at both falling and rising edges of $\overline{\text{IRQ7}}$ to $\overline{\text{IRQ0}}$ input

5.2.5 IRQ Status Register (ISR)

Bit	:	7	6	5	4	3	2	1	0
		IRQ7F	IRQ6F	IRQ5F	IRQ4F	IRQ3F	IRQ2F	IRQ1F	IRQ0F
Initial value:		0	0	0	0	0	0	0	0
R/W	:	R/(W)*	R/(W)*	R/(W)*	R/(W)*	R/(W)*	R/(W)*	R/(W)*	R/(W)*

Note: * Only 0 can be written, to clear the flag.

ISR is an 8-bit readable/writable register that indicates the status of IRQ7 to IRQ0 interrupt requests.

ISR is initialized to H'00 by a reset and in hardware standby mode.

Bits 7 to 0—IRQ7 to IRQ0 flags (IRQ7F to IRQ0F): These bits indicate the status of IRQ7 to IRQ0 interrupt requests.

Bit n

IRQnF Description

0	[Clearing conditions] (Initial value)
	<ul style="list-style-type: none"> • Cleared by reading IRQnF flag when $IRQnF = 1$, then writing 0 to IRQnF flag • When interrupt exception handling is executed when low-level detection is set ($IRQnSCB = IRQnSCA = 0$) and \overline{IRQn} input is high • When IRQn interrupt exception handling is executed when falling, rising, or both-edge detection is set ($IRQnSCB = 1$ or $IRQnSCA = 1$) • When the DTC is activated by an IRQn interrupt, and the DISEL bit in MRB of the DTC is cleared to 0
1	[Setting conditions]
	<ul style="list-style-type: none"> • When \overline{IRQn} input goes low when low-level detection is set ($IRQnSCB = IRQnSCA = 0$) • When a falling edge occurs in \overline{IRQn} input when falling edge detection is set ($IRQnSCB = 0$, $IRQnSCA = 1$) • When a rising edge occurs in \overline{IRQn} input when rising edge detection is set ($IRQnSCB = 1$, $IRQnSCA = 0$) • When a falling or rising edge occurs in \overline{IRQn} input when both-edge detection is set ($IRQnSCB = IRQnSCA = 1$)

(n = 7 to 0)

5.3 Interrupt Sources

Interrupt sources comprise external interrupts (NMI and IRQ7 to IRQ0) and internal interrupts (47 sources).

5.3.1 External Interrupts

There are nine external interrupts: NMI and IRQ7 to IRQ0. Of these, NMI and IRQ2 to IRQ0 can be used to restore the H8S/2355 Series from software standby mode.

NMI Interrupt: NMI is the highest-priority interrupt, and is always accepted by the CPU regardless of the status of the CPU interrupt mask bits. The NMIEG bit in SYSCR can be used to select whether an interrupt is requested at a rising edge or a falling edge on the NMI pin.

The vector number for NMI interrupt exception handling is 7.

IRQ7 to IRQ0 Interrupts: Interrupts IRQ7 to IRQ0 are requested by an input signal at pins $\overline{\text{IRQ7}}$ to $\overline{\text{IRQ0}}$. Interrupts IRQ7 to IRQ0 have the following features:

- Using ISCR, it is possible to select whether an interrupt is generated by a low level, falling edge, rising edge, or both edges, at pins $\overline{\text{IRQ7}}$ to $\overline{\text{IRQ0}}$.
- Enabling or disabling of interrupt requests IRQ7 to IRQ0 can be selected with IER.
- The interrupt priority level can be set with IPR.
- The status of interrupt requests IRQ7 to IRQ0 is indicated in ISR. ISR flags can be cleared to 0 by software.

A block diagram of interrupts IRQ7 to IRQ0 is shown in figure 5-2.

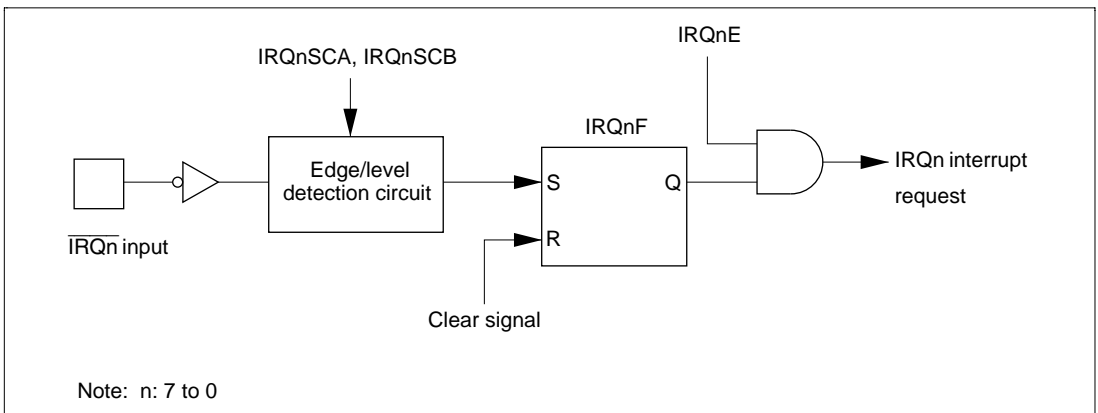

Figure 5-2 Block Diagram of Interrupts IRQ7 to IRQ0

Figure 5-3 shows the timing of setting IRQnF.

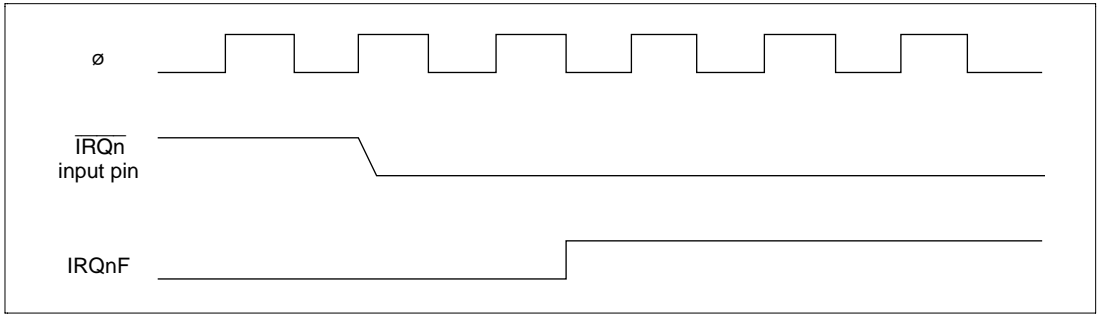

Figure 5-3 Timing of Setting IRQnF

The vector numbers for IRQ7 to IRQ0 interrupt exception handling are 23 to 16.

Detection of IRQ7 to IRQ0 interrupts does not depend on whether the relevant pin has been set for input or output. However, when a pin is used as an external interrupt input pin, do not clear the corresponding DDR to 0 and use the pin as an I/O pin for another function.

5.3.2 Internal Interrupts

There are 47 sources for internal interrupts from on-chip supporting modules.

- For each on-chip supporting module there are flags that indicate the interrupt request status, and enable bits that select enabling or disabling of these interrupts. If both of these are set to 1 for a particular interrupt source, an interrupt request is issued to the interrupt controller.
- The interrupt priority level can be set by means of IPR.
- The DTC can be activated by a TPU, 8-bit timer, SCI, or other interrupt request. When the DTC is activated by an interrupt, the interrupt control mode and interrupt mask bits are not affected.

5.3.3 Interrupt Exception Handling Vector Table

Table 5-4 shows interrupt exception handling sources, vector addresses, and interrupt priorities. For default priorities, the lower the vector number, the higher the priority.

Priorities among modules can be set by means of the IPR. The situation when two or more modules are set to the same priority, and priorities within a module, are fixed as shown in table 5-4.

Table 5-4 Interrupt Sources, Vector Addresses, and Interrupt Priorities

Interrupt Source	Origin of Interrupt Source	Vector Number	Vector Address*		IPR	Priority
			Normal Mode	Advanced Mode		
NMI	External pin	7	H'000E	H'001C		High ↑
IRQ0		16	H'0020	H'0040	IPRA6 to 4	
IRQ1		17	H'0022	H'0044	IPRA2 to 0	
IRQ2		18	H'0024	H'0048	IPRB6 to 4	
IRQ3		19	H'0026	H'004C		
IRQ4		20	H'0028	H'0050	IPRB2 to 0	
IRQ5		21	H'002A	H'0054		
IRQ6		22	H'002C	H'0058	IPRC6 to 4	
IRQ7		23	H'002E	H'005C		
SWDTEND (software activation interrupt end)		DTC	24	H'0030	H'0060	
WOVI (interval timer)	Watchdog timer	25	H'0032	H'0064	IPRD6 to 4	
Reserved	—	26	H'0034	H'0068		
		27	H'0036	H'006C		
ADI (A/D conversion end)	A/D	28	H'0038	H'0070	IPRE2 to 0	
Reserved	—	29	H'003A	H'0074		
		30	H'003C	H'0078		
		31	H'003E	H'007C		
TGI0A (TGR0A input capture/compare match)	TPU channel 0	32	H'0040	H'0080	IPRF6 to 4	
TGI0B (TGR0B input capture/compare match)		33	H'0042	H'0084		
TGI0C (TGR0C input capture/compare match)		34	H'0044	H'0088		
TGI0D (TGR0D input capture/compare match)		35	H'0046	H'008C		
TCI0V (overflow 0)		36	H'0048	H'0090		
Reserved	—	37	H'004A	H'0094		
		38	H'004C	H'0098		
		39	H'004E	H'009C		

Low

Interrupt Source	Origin of Interrupt Source	Vector Number	Vector Address*		IPR	Priority
			Normal Mode	Advanced Mode		
TGI1A (TGR1A input capture/compare match)	TPU channel 1	40	H'0050	H'00A0	IPRF2 to 0	High ↑
TGI1B (TGR1B input capture/compare match)		41	H'0052	H'00A4		
TCI1V (overflow 1)		42	H'0054	H'00A8		
TCI1U (underflow 1)		43	H'0056	H'00AC		
TGI2A (TGR2A input capture/compare match)	TPU channel 2	44	H'0058	H'00B0	IPRG6 to 4	
TGI2B (TGR2B input capture/compare match)		45	H'005A	H'00B4		
TCI2V (overflow 2)		46	H'005C	H'00B8		
TCI2U (underflow 2)		47	H'005E	H'00BC		
TGI3A (TGR3A input capture/compare match)	TPU channel 3	48	H'0060	H'00C0	IPRG2 to 0	
TGI3B (TGR3B input capture/compare match)		49	H'0062	H'00C4		
TGI3C (TGR3C input capture/compare match)		50	H'0064	H'00C8		
TGI3D (TGR3D input capture/compare match)		51	H'0066	H'00CC		
TCI3V (overflow 1)		52	H'0068	H'00D0		
Reserved	—	53	H'006A	H'00D4		
		54	H'006C	H'00D8		
		55	H'006E	H'00DC		
TGI4A (TGR4A input capture/compare match)	TPU channel 4	56	H'0070	H'00E0	IPRH6 to 4	
TGI4B (TGR4B input capture/compare match)		57	H'0072	H'00E4		
TCI4V (overflow 4)		58	H'0074	H'00E8		
TCI4U (underflow 4)		59	H'0076	H'00EC		
TGI5A (TGR5A input capture/compare match)	TPU channel 5	60	H'0078	H'00F0	IPRH2 to 0	
TGI5B (TGR5B input capture/compare match)		61	H'007A	H'00F4		
TCI5V (overflow 5)		62	H'007C	H'00F8		
TCI5U (underflow 5)		63	H'007E	H'00FC		

Interrupt Source	Origin of Interrupt Source	Vector Number	Vector Address*		IPR	Priority
			Normal Mode	Advanced Mode		
CMIA0 (compare match A0)	8-bit timer channel 0	64	H'0080	H'0100	IPR16 to 4	High ↑
CMIB0 (compare match B0)		65	H'0082	H'0104		
OVI0 (overflow 0)		66	H'0084	H'0108		
Reserved	—	67	H'0086	H'010C		
CMIA1 (compare match A1)	8-bit timer channel 1	68	H'0088	H'0110	IPR12 to 0	
CMIB1 (compare match B1)		69	H'008A	H'0114		
OVI1 (overflow 1)		70	H'008C	H'0118		
Reserved	—	71	H'008E	H'011C		
		72	H'0090	H'0120		
		73	H'0092	H'0124		
		74	H'0094	H'0128		
		75	H'0096	H'012C		
		76	H'0098	H'0130		
		77	H'009A	H'0134		
		78	H'009C	H'0138		
		79	H'009E	H'013C		
ERI0 (receive error 0)	SCI channel 0	80	H'00A0	H'0140	IPRJ2 to 0	
RXI0 (reception completed 0)		81	H'00A2	H'0144		
TXI0 (transmit data empty 0)		82	H'00A4	H'0148		
TEI0 (transmission end 0)		83	H'00A6	H'014C		
ERI1 (receive error 1)	SCI channel 1	84	H'00A8	H'0150	IPRK6 to 4	
RXI1 (reception completed 1)		85	H'00AA	H'0154		
TXI1 (transmit data empty 1)		86	H'00AC	H'0158		
TEI1 (transmission end 1)		87	H'00AE	H'015C		
ERI2 (receive error 2)	SCI channel 2	88	H'00B0	H'0160	IPRK2 to 0	
RXI2 (reception completed 2)		89	H'00B2	H'0164		
TXI2 (transmit data empty 2)		90	H'00B4	H'0168		
TEI2 (transmission end 2)		91	H'00B6	H'016C		

Note: * Lower 16 bits of the start address.

5.4 Interrupt Operation

5.4.1 Interrupt Control Modes and Interrupt Operation

Interrupt operations in the H8S/2355 Series differ depending on the interrupt control mode.

NMI interrupts are accepted at all times except in the reset state and the hardware standby state. In the case of IRQ interrupts and on-chip supporting module interrupts, an enable bit is provided for each interrupt. Clearing an enable bit to 0 disables the corresponding interrupt request. Interrupt sources for which the enable bits are set to 1 are controlled by the interrupt controller.

Table 5-5 shows the interrupt control modes.

The interrupt controller performs interrupt control according to the interrupt control mode set by the INTM1 and INTM0 bits in SYSCR, the priorities set in IPR, and the masking state indicated by the I and UI bits in the CPU's CCR, and bits I2 to I0 in EXR.

Table 5-5 Interrupt Control Modes

Interrupt Control Mode	SYSCR		Priority Setting Registers	Interrupt Mask Bits	Description
	INTM1	INTM0			
0	0	0	—	I	Interrupt mask control is performed by the I bit.
—	—	1	—	—	Setting prohibited
2	1	0	IPR	I2 to I0	8-level interrupt mask control is performed by bits I2 to I0. 8 priority levels can be set with IPR.
—	—	1	—	—	Setting prohibited

Figure 5-4 shows a block diagram of the priority decision circuit.

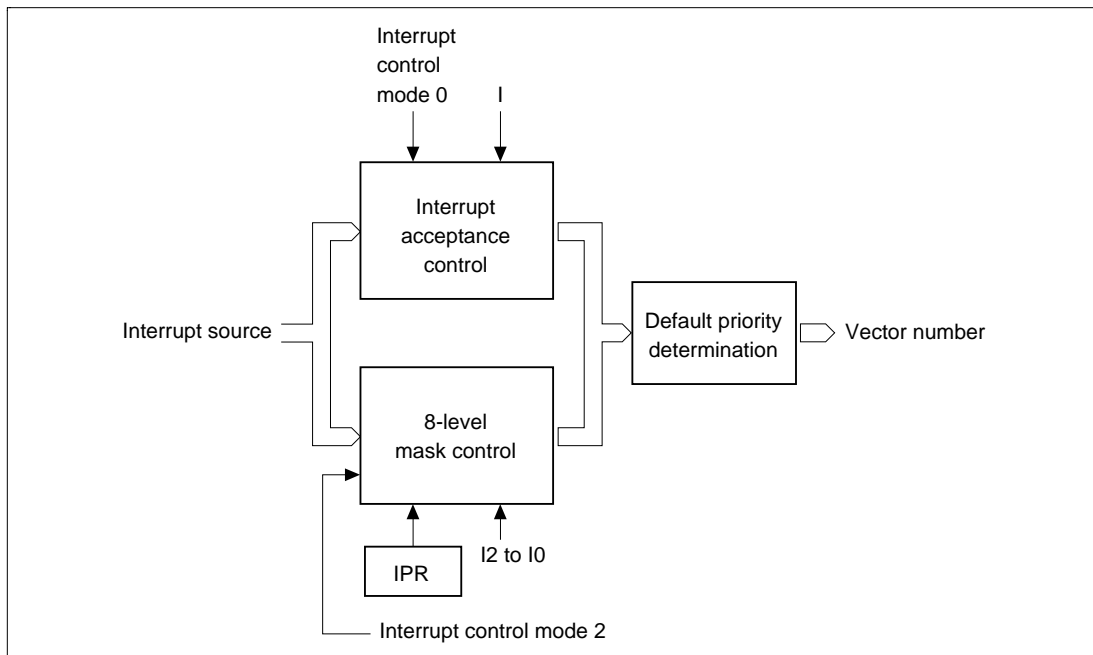

Figure 5-4 Block Diagram of Interrupt Control Operation

(1) Interrupt Acceptance Control

In interrupt control mode 0, interrupt acceptance is controlled by the I bit in CCR.

Table 5-6 shows the interrupts selected in each interrupt control mode.

Table 5-6 Interrupts Selected in Each Interrupt Control Mode (1)

Interrupt Control Mode	Interrupt Mask Bits	
	I	Selected Interrupts
0	0	All interrupts
	1	NMI interrupts
2	*	All interrupts

Legend

* : Don't care

(2) 8-Level Control

In interrupt control mode 2, 8-level mask level determination is performed for the selected interrupts in interrupt acceptance control according to the interrupt priority level (IPR).

The interrupt source selected is the interrupt with the highest priority level, and whose priority level set in IPR is higher than the mask level.

Table 5-7 Interrupts Selected in Each Interrupt Control Mode (2)

Interrupt Control Mode	Selected Interrupts
0	All interrupts
2	Highest-priority-level (IPR) interrupt whose priority level is greater than the mask level (IPR > I2 to I0).

(3) Default Priority Determination

When an interrupt is selected by 8-level control, its priority is determined and a vector number is generated.

If the same value is set for IPR, acceptance of multiple interrupts is enabled, and so only the interrupt source with the highest priority according to the preset default priorities is selected and has a vector number generated.

Interrupt sources with a lower priority than the accepted interrupt source are held pending.

Table 5-8 shows operations and control signal functions in each interrupt control mode.

Table 5-8 Operations and Control Signal Functions in Each Interrupt Control Mode

Interrupt Control Mode	Setting		Interrupt Acceptance Control		8-Level Control		Default Priority Determination	T (Trace)	
	INTM1	INTM0	I	IM	I2 to I0	IPR			
0	0	0	○	IM	X	—	—*2	○	—
2	1	0	X	—*1	○	IM	PR	○	T

Legend

- : Interrupt operation control performed
- X : No operation. (All interrupts enabled)
- IM : Used as interrupt mask bit
- PR : Sets priority.
- : Not used.

Notes: 1. Set to 1 when interrupt is accepted.
2. Keep the initial setting.

5.4.2 Interrupt Control Mode 0

Enabling and disabling of IRQ interrupts and on-chip supporting module interrupts can be set by means of the I bit in the CPU's CCR. Interrupts are enabled when the I bit is cleared to 0, and disabled when set to 1.

Figure 5-5 shows a flowchart of the interrupt acceptance operation in this case.

- [1] If an interrupt source occurs when the corresponding interrupt enable bit is set to 1, an interrupt request is sent to the interrupt controller.
- [2] The I bit is then referenced. If the I bit is cleared to 0, the interrupt request is accepted. If the I bit is set to 1, only an NMI interrupt is accepted, and other interrupt requests are held pending.
- [3] Interrupt requests are sent to the interrupt controller, the highest-ranked interrupt according to the priority system is accepted, and other interrupt requests are held pending.
- [4] When an interrupt request is accepted, interrupt exception handling starts after execution of the current instruction has been completed.
- [5] The PC and CCR are saved to the stack area by interrupt exception handling. The PC saved on the stack shows the address of the first instruction to be executed after returning from the interrupt handling routine.
- [6] Next, the I bit in CCR is set to 1. This masks all interrupts except NMI.
- [7] A vector address is generated for the accepted interrupt, and execution of the interrupt handling routine starts at the address indicated by the contents of that vector address.

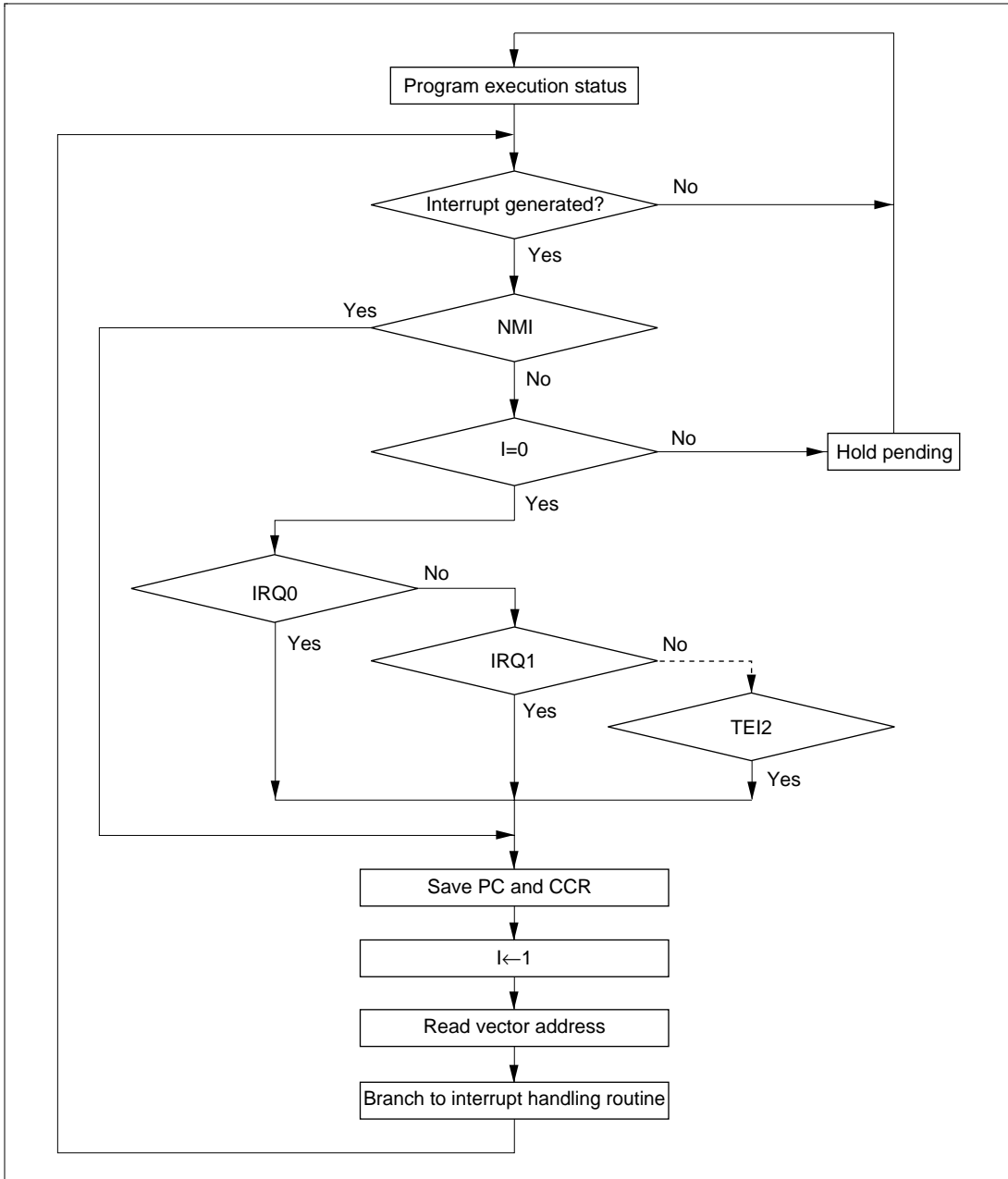

Figure 5-5 Flowchart of Procedure Up to Interrupt Acceptance in Interrupt Control Mode 0

5.4.3 Interrupt Control Mode 2

Eight-level masking is implemented for IRQ interrupts and on-chip supporting module interrupts by comparing the interrupt mask level set by bits I2 to I0 of EXR in the CPU with IPR.

Figure 5-6 shows a flowchart of the interrupt acceptance operation in this case.

- [1] If an interrupt source occurs when the corresponding interrupt enable bit is set to 1, an interrupt request is sent to the interrupt controller.
- [2] When interrupt requests are sent to the interrupt controller, the interrupt with the highest priority according to the interrupt priority levels set in IPR is selected, and lower-priority interrupt requests are held pending. If a number of interrupt requests with the same priority are generated at the same time, the interrupt request with the highest priority according to the priority system shown in table 5-4 is selected.
- [3] Next, the priority of the selected interrupt request is compared with the interrupt mask level set in EXR. An interrupt request with a priority no higher than the mask level set at that time is held pending, and only an interrupt request with a priority higher than the interrupt mask level is accepted.
- [4] When an interrupt request is accepted, interrupt exception handling starts after execution of the current instruction has been completed.
- [5] The PC, CCR, and EXR are saved to the stack area by interrupt exception handling. The PC saved on the stack shows the address of the first instruction to be executed after returning from the interrupt handling routine.
- [6] The T bit in EXR is cleared to 0. The interrupt mask level is rewritten with the priority level of the accepted interrupt.
If the accepted interrupt is NMI, the interrupt mask level is set to H'7.
- [7] A vector address is generated for the accepted interrupt, and execution of the interrupt handling routine starts at the address indicated by the contents of that vector address.

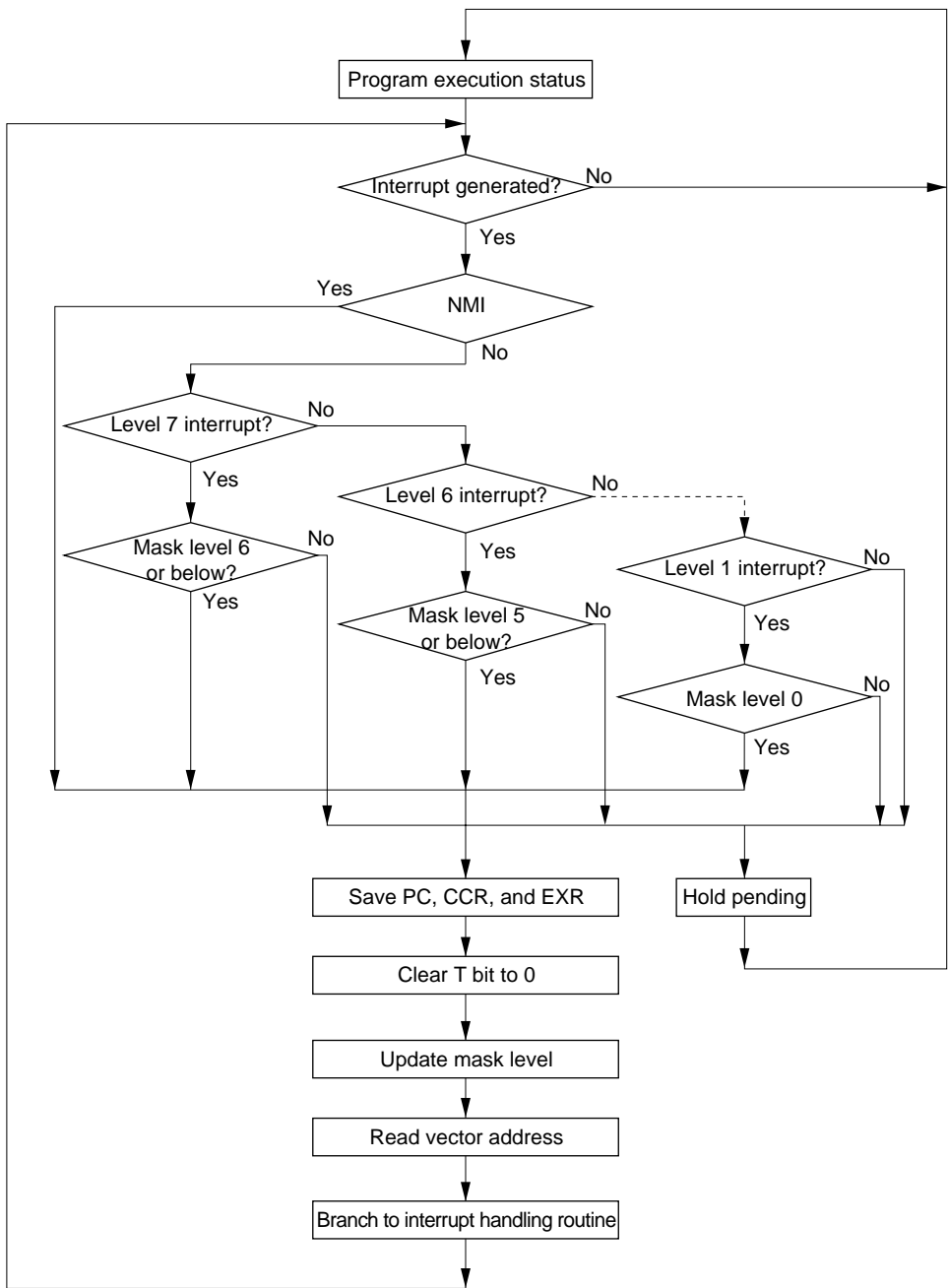
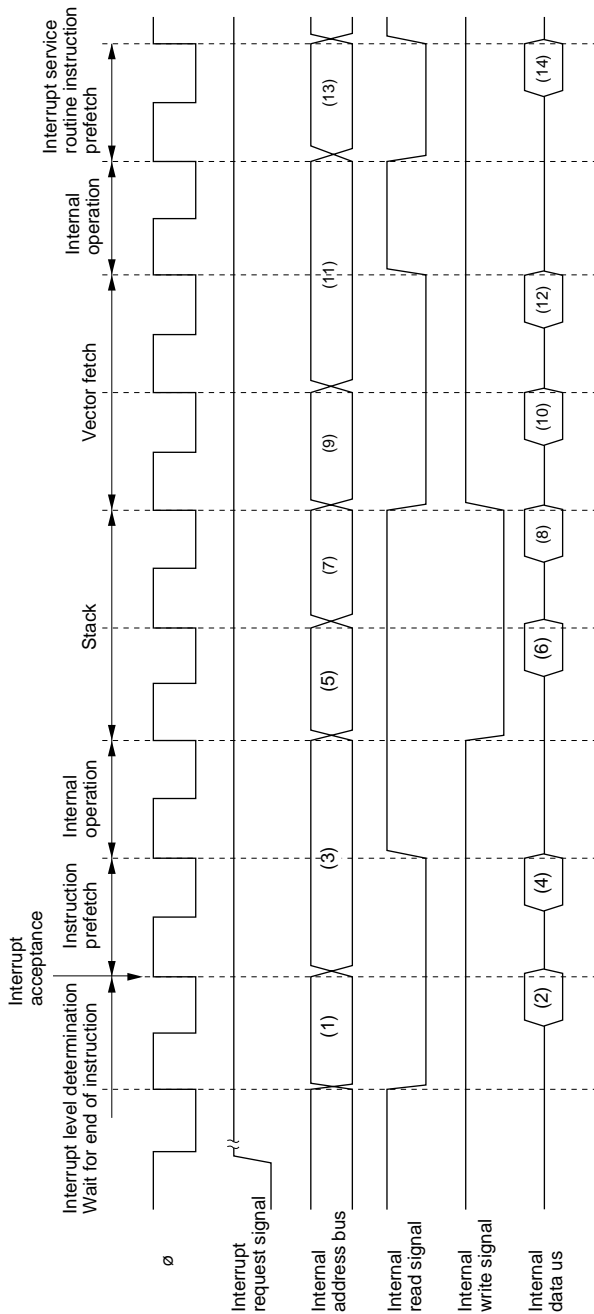

Figure 5-6 Flowchart of Procedure Up to Interrupt Acceptance in Interrupt Control Mode 2

5.4.4 Interrupt Exception Handling Sequence

Figure 5-7 shows the interrupt exception handling sequence. The example shown is for the case where interrupt control mode 0 is set in advanced mode, and the program area and stack area are in on-chip memory.



- (1) Instruction prefetch address (Not executed. This is the contents of the saved PC, the return address.)
- (2) (4) Instruction code (Not executed.)
- (3) Instruction prefetch address (Not executed.)
- (5) SP-2
- (7) SP-4
- (6) (8) Saved PC and saved CCR
- (9) (11) Vector address
- (10) (12) Interrupt handling routine start address (vector address contents)
- (13) Interrupt handling routine start address ((13) = (10) (12))
- (14) First instruction of interrupt handling routine

Figure 5-7 Interrupt Exception Handling

5.4.5 Interrupt Response Times

The H8S/2355 Series is capable of fast word transfer instruction to on-chip memory, and the program area is provided in on-chip ROM and the stack area in on-chip RAM, enabling high-speed processing.

Table 5-9 shows interrupt response times - the interval between generation of an interrupt request and execution of the first instruction in the interrupt handling routine. The execution status symbols used in table 5-9 are explained in table 5-10.

Table 5-9 Interrupt Response Times

No.	Execution Status	Normal Mode		Advanced Mode	
		INTM1 = 0	INTM1 = 1	INTM1 = 0	INTM1 = 1
1	Interrupt priority determination* ¹	3	3	3	3
2	Number of wait states until executing instruction ends* ²	1 to 19+2·S _I	1 to 19+2·S _I	1 to 19+2·S _I	1 to 19+2·S _I
3	PC, CCR, EXR stack save	2·S _K	3·S _K	2·S _K	3·S _K
4	Vector fetch	S _I	S _I	2·S _I	2·S _I
5	Instruction fetch* ³	2·S _I	2·S _I	2·S _I	2·S _I
6	Internal processing* ⁴	2	2	2	2
Total (using on-chip memory)		11 to 31	12 to 32	12 to 32	13 to 33

- Notes: 1. Two states in case of internal interrupt.
 2. Refers to MULXS and DIVXS instructions.
 3. Prefetch after interrupt acceptance and interrupt handling routine prefetch.
 4. Internal processing after interrupt acceptance and internal processing after vector fetch.

Table 5-10 Number of States in Interrupt Handling Routine Execution Statuses

Symbol		Internal Memory	Object of Access			
			External Device			
			8 Bit Bus		16 Bit Bus	
			2-State Access	3-State Access	2-State Access	3-State Access
Instruction fetch	S _I	1	4	6+2m	2	3+m
Branch address read	S _J					
Stack manipulation	S _K					

Legend

m : Number of wait states in an external device access.

5.5 Usage Notes

5.5.1 Contention between Interrupt Generation and Disabling

When an interrupt enable bit is cleared to 0 to disable interrupts, the disabling becomes effective after execution of the instruction.

In other words, when an interrupt enable bit is cleared to 0 by an instruction such as BCLR or MOV, if an interrupt is generated during execution of the instruction, the interrupt concerned will still be enabled on completion of the instruction, and so interrupt exception handling for that interrupt will be executed on completion of the instruction. However, if there is an interrupt request of higher priority than that interrupt, interrupt exception handling will be executed for the higher-priority interrupt, and the lower-priority interrupt will be ignored.

The same also applies when an interrupt source flag is cleared.

Figure 5-8 shows an example in which the CMIEA bit in 8-bit timer TCR is cleared to 0.

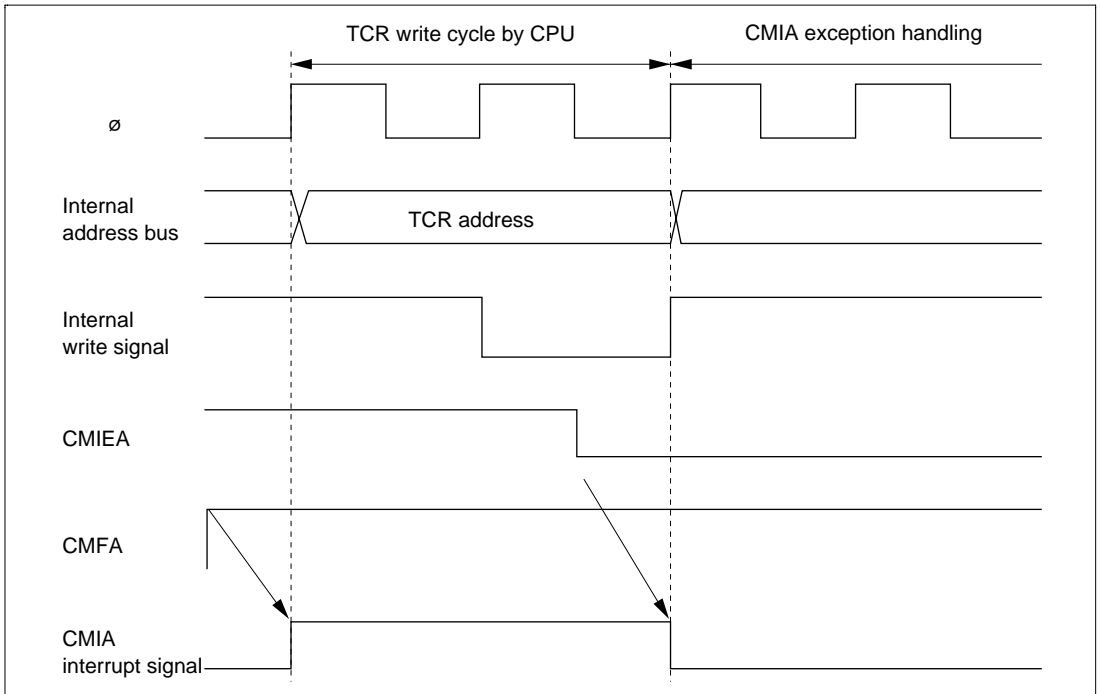

Figure 5-8 Contention between Interrupt Generation and Disabling

The above contention will not occur if an enable bit or interrupt source flag is cleared to 0 while the interrupt is masked.

5.5.2 Instructions that Disable Interrupts

Instructions that disable interrupts are LDC, ANDC, ORC, and XORC. After any of these instructions is executed, all interrupts including NMI are disabled and the next instruction is always executed. When the I bit is set by one of these instructions, the new value becomes valid two states after execution of the instruction ends.

5.5.3 Times when Interrupts are Disabled

There are times when interrupt acceptance is disabled by the interrupt controller.

The interrupt controller disables interrupt acceptance for a 3-state period after the CPU has updated the mask level with an LDC, ANDC, ORC, or XORC instruction.

5.5.4 Interrupts during Execution of EEPMOV Instruction

Interrupt operation differs between the EEPMOV.B instruction and the EEPMOV.W instruction.

With the EEPMOV.B instruction, an interrupt request (including NMI) issued during the transfer is not accepted until the move is completed.

With the EEPMOV.W instruction, if an interrupt request is issued during the transfer, interrupt exception handling starts at a break in the transfer cycle. The PC value saved on the stack in this case is the address of the next instruction.

Therefore, if an interrupt is generated during execution of an EEPMOV.W instruction, the following coding should be used.

```
L1:  EEPMOV.W
      MOV.W   R4,R4
      BNE    L1
```

5.6 DTC Activation by Interrupt

5.6.1 Overview

The DTC can be activated by an interrupt. In this case, the following options are available:

- Interrupt request to CPU
- Activation request to DTC
- Selection of a number of the above

For details of interrupt requests that can be used with to activate the DTC, see section 7, Data Transfer Controller.

5.6.2 Block Diagram

Figure 5-9 shows a block diagram of the DTC interrupt controller.

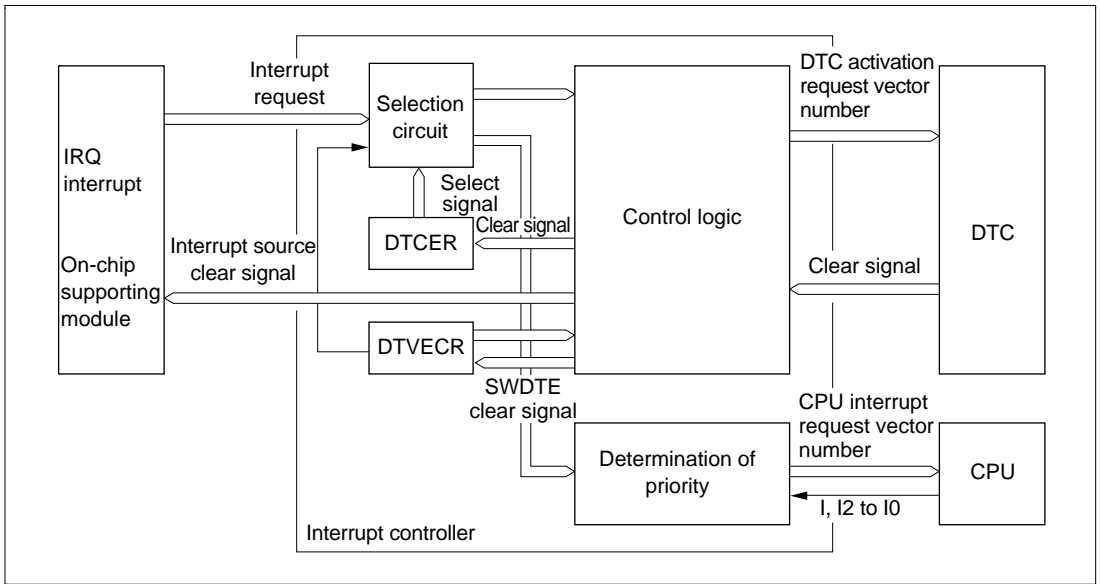

Figure 5-9 Interrupt Control for DTC and DMAC

5.6.3 Operation

The interrupt controller has three main functions in DTC control.

(1) Selection of Interrupt Source: Interrupt sources can be specified as DTC activation requests or CPU interrupt requests by means of the DTCE bit of DTCEA to DTCEF in the DTC.

After a DTC data transfer, the DTCE bit can be cleared to 0 and an interrupt request sent to the CPU in accordance with the specification of the DISEL bit of MRB in the DTC.

When the DTC has performed the specified number of data transfers and the transfer counter value is zero, the DTCE bit is cleared to 0 and an interrupt request is sent to the CPU after the DTC data transfer.

(2) Determination of Priority: The DTC activation source is selected in accordance with the default priority order, and is not affected by mask or priority levels. See section 7.3.3, DTC Vector Table, for the respective priorities.

(3) Operation Order: If the same interrupt is selected as a DTC activation source and a CPU interrupt source, the DTC data transfer is performed first, followed by CPU interrupt exception handling.

If the same interrupt is selected as a DTC activation source or CPU interrupt source, operations are performed for them independently according to their respective operating statuses and bus mastership priorities.

Table 5-11 summarizes interrupt source selection and interrupt source clearance control according to the settings of the DTCE bit of DTCEA to DTCEF in the DTC and the DISEL bit of MRB in the DTC.

Table 5-11 Interrupt Source Selection and Clearing Control

Settings		Interrupt Source Selection/Clearing Control	
DTC		DTC	CPU
DTCE	DISEL		
0	*	X	Δ
1	0	Δ	X
	1	○	Δ

Legend

- Δ : The relevant interrupt is used. Interrupt source clearing is performed.
(The CPU should clear the source flag in the interrupt handling routine.)
- : The relevant interrupt is used. The interrupt source is not cleared.
- X : The relevant bit cannot be used.
- * : Don't care

(4) Notes on Use: SCI and A/D converter interrupt sources are cleared when the DTC reads or writes to the prescribed register, and are not dependent upon the DISEL bit.

Section 6 Bus Controller

6.1 Overview

The H8S/2355 Series has a built-in bus controller (BSC) that manages the external address space divided into eight areas. The bus specifications, such as bus width and number of access states, can be set independently for each area, enabling multiple memories to be connected easily.

The bus controller also has a bus arbitration function, and controls the operation of the internal bus masters: the CPU and data transfer controller (DTC).

6.1.1 Features

The features of the bus controller are listed below.

- Manages external address space in area units
 - In advanced mode, manages the external space as 8 areas of 2-Mbytes
 - In normal mode, manages the external space as a single area
 - Bus specifications can be set independently for each area
- Basic bus interface
 - Chip select ($\overline{CS0}$ to $\overline{CS7}$) can be output for areas 0 to 7
 - 8-bit access or 16-bit access can be selected for each area
 - 2-state access or 3-state access can be selected for each area
 - Program wait states can be inserted for each area
- Burst ROM interface
 - Burst ROM interface can be set for area 0
 - Choice of 1- or 2-state burst access
- Idle cycle insertion
 - An idle cycle can be inserted in case of an external read cycle between different areas
 - An idle cycle can be inserted in case of an external write cycle immediately after an external read cycle
- Bus arbitration function
 - Includes a bus arbiter that arbitrates bus mastership among the CPU and DTC
- Other features
 - External bus release function

6.1.2 Block Diagram

Figure 6-1 shows a block diagram of the bus controller.

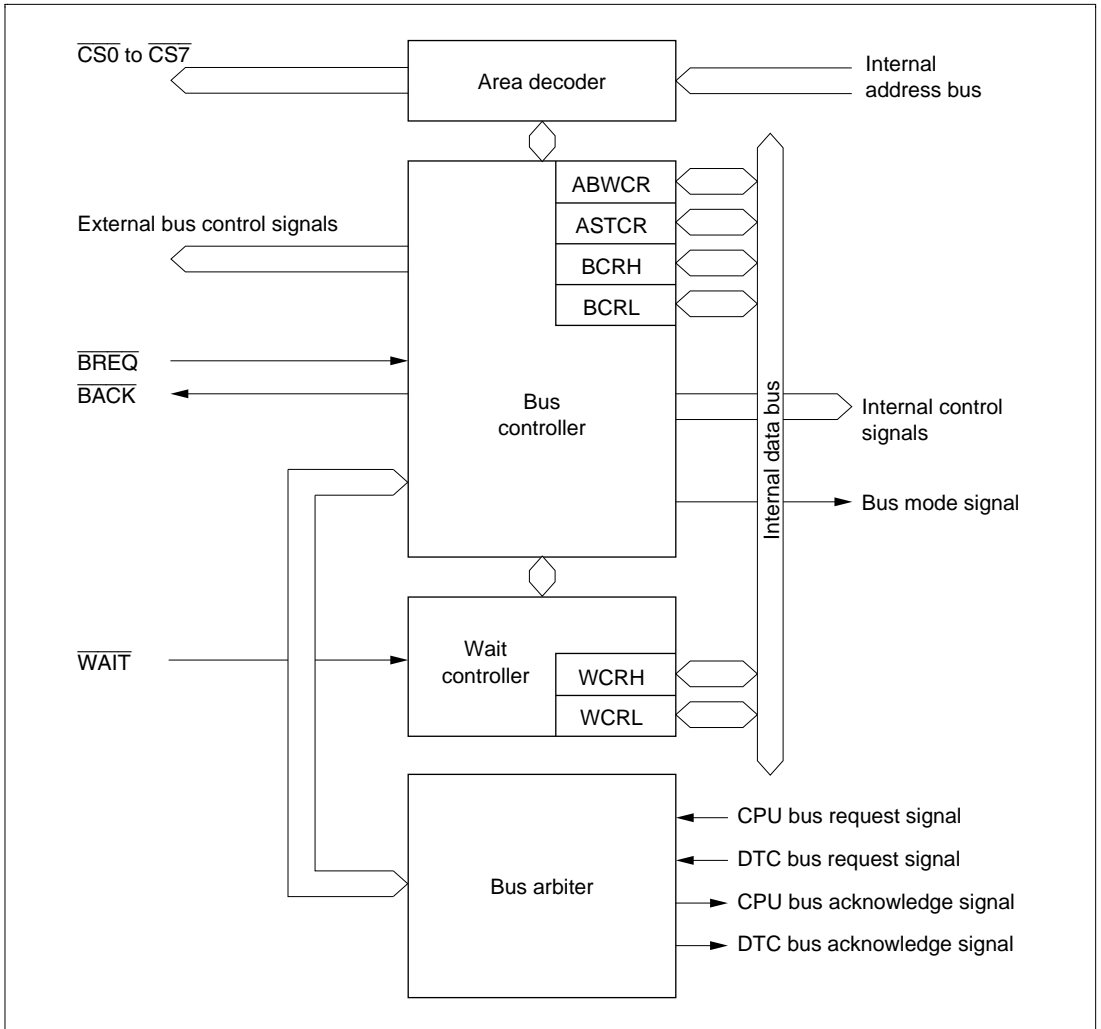

Figure 6-1 Block Diagram of Bus Controller

6.1.3 Pin Configuration

Table 6-1 summarizes the pins of the bus controller.

Table 6-1 Bus Controller Pins

Name	Symbol	I/O	Function
Address strobe	\overline{AS}	Output	Strobe signal indicating that address output on address bus is enabled.
Read	\overline{RD}	Output	Strobe signal indicating that external space is being read.
High write	\overline{HWR}	Output	Strobe signal indicating that external space is to be written, and upper half (D_{15} to D_8) of data bus is enabled.
Low write	\overline{LWR}	Output	Strobe signal indicating that external space is to be written, and lower half (D_7 to D_0) of data bus is enabled.
Chip select 0 to 7	$\overline{CS0}$ to $\overline{CS7}$	Output	Strobe signal indicating that areas 0 to 7 are selected.
Wait	\overline{WAIT}	Input	Wait request signal when accessing external 3-state access space.
Bus request	\overline{BREQ}	Input	Request signal that releases bus to external device.
Bus request acknowledge	\overline{BACK}	Output	Acknowledge signal indicating that bus has been released.

6.1.4 Register Configuration

Table 6-2 summarizes the registers of the bus controller.

Table 6-2 Bus Controller Registers

Name	Abbreviation	R/W	Initial Value		Address* ¹
			Power-On Reset	Manual Reset	
Bus width control register	ABWCR	R/W	H'FF/H'00* ²	Retained	H'FED0
Access state control register	ASTCR	R/W	H'FF	Retained	H'FED1
Wait control register H	WCRH	R/W	H'FF	Retained	H'FED2
Wait control register L	WCRL	R/W	H'FF	Retained	H'FED3
Bus control register H	BCRH	R/W	H'D0	Retained	H'FED4
Bus control register L	BCRL	R/W	H'3C	Retained	H'FED5

Notes: 1. Lower 16 bits of the address.

2. Determined by the MCU operating mode.

6.2 Register Descriptions

6.2.1 Bus Width Control Register (ABWCR)

Bit	:	7	6	5	4	3	2	1	0
		ABW7	ABW6	ABW5	ABW4	ABW3	ABW2	ABW1	ABW0
Modes 1 to 3, 5 to 7									
Initial value	:	1	1	1	1	1	1	1	1
RW	:	R/W	R/W	R/W	R/W	R/W	R/W	R/W	R/W
Mode 4									
Initial value	:	0	0	0	0	0	0	0	0
RW	:	R/W	R/W	R/W	R/W	R/W	R/W	R/W	R/W

ABWCR is an 8-bit readable/writable register that designates each area for either 8-bit access or 16-bit access.

ABWCR sets the data bus width for the external memory space. The bus width for on-chip memory and internal I/O registers is fixed regardless of the settings in ABWCR.

In normal mode, the settings of bits ABW7 to ABW1 have no effect on operation.

After a power-on reset and in hardware standby mode, ABWCR is initialized to H'FF in modes 1, 2, 3, and 5, 6, 7, and to H'00 in mode 4. It is not initialized by a manual reset or in software standby mode.

Bits 7 to 0—Area 7 to 0 Bus Width Control (ABW7 to ABW0): These bits select whether the corresponding area is to be designated for 8-bit access or 16-bit access. In normal mode, only part of area 0 is enabled, and the ABW0 bit selects whether external space is to be designated for 8-bit access or 16-bit access.

Bit n

ABWn	Description
0	Area n is designated for 16-bit access
1	Area n is designated for 8-bit access

(n = 7 to 0)

6.2.2 Access State Control Register (ASTCR)

Bit	:	7	6	5	4	3	2	1	0
		AST7	AST6	AST5	AST4	AST3	AST2	AST1	AST0
Initial value	:	1	1	1	1	1	1	1	1
R/W	:	R/W	R/W	R/W	R/W	R/W	R/W	R/W	R/W

ASTCR is an 8-bit readable/writable register that designates each area as either a 2-state access space or a 3-state access space.

ASTCR sets the number of access states for the external memory space. The number of access states for on-chip memory and internal I/O registers is fixed regardless of the settings in ASTCR.

In normal mode, the settings of bits AST7 to AST1 have no effect on operation.

ASTCR is initialized to H'FF by a power-on reset and in hardware standby mode. It is not initialized by a manual reset or in software standby mode.

Bits 7 to 0—Area 7 to 0 Access State Control (AST7 to AST0): These bits select whether the corresponding area is to be designated as a 2-state access space or a 3-state access space. In normal mode, only part of area 0 is enabled, and the AST0 bit selects whether external space is to be designated for 2-state access or 3-state access.

Wait state insertion is enabled or disabled at the same time.

Bit n

ASTn	Description
0	Area n is designated for 2-state access Wait state insertion in area n external space is disabled
1	Area n is designated for 3-state access Wait state insertion in area n external space is enabled

(Initial value)

(n = 7 to 0)

6.2.3 Wait Control Registers H and L (WCRH, WCRL)

WCRH and WCRL are 8-bit readable/writable registers that select the number of program wait states for each area.

In normal mode, only part of area is 0 is enabled, and bits W01 and W00 select the number of program wait states for the external space . The settings of bits W71, W70 to W11, and W10 have no effect on operation.

Program waits are not inserted in the case of on-chip memory or internal I/O registers.

WCRH and WCRL are initialized to H'FF by a power-on reset and in hardware standby mode. They are not initialized by a manual reset or in software standby mode.

(1) WCRH

Bit	:	7	6	5	4	3	2	1	0
		W71	W70	W61	W60	W51	W50	W41	W40
Initial value	:	1	1	1	1	1	1	1	1
R/W	:	R/W	R/W	R/W	R/W	R/W	R/W	R/W	R/W

Bits 7 and 6—Area 7 Wait Control 1 and 0 (W71, W70): These bits select the number of program wait states when area 7 in external space is accessed while the AST7 bit in ASTCR is set to 1.

Bit 7	Bit 6	Description
W71	W70	
0	0	Program wait not inserted when external space area 7 is accessed
	1	1 program wait state inserted when external space area 7 is accessed
1	0	2 program wait states inserted when external space area 7 is accessed
	1	3 program wait states inserted when external space area 7 is accessed (Initial value)

Bits 5 and 4—Area 6 Wait Control 1 and 0 (W61, W60): These bits select the number of program wait states when area 6 in external space is accessed while the AST6 bit in ASTCR is set to 1.

Bit 5	Bit 4	
W61	W60	Description
0	0	Program wait not inserted when external space area 6 is accessed
	1	1 program wait state inserted when external space area 6 is accessed
1	0	2 program wait states inserted when external space area 6 is accessed
	1	3 program wait states inserted when external space area 6 is accessed (Initial value)

Bits 3 and 2—Area 5 Wait Control 1 and 0 (W51, W50): These bits select the number of program wait states when area 5 in external space is accessed while the AST5 bit in ASTCR is set to 1.

Bit 3	Bit 2	
W51	W50	Description
0	0	Program wait not inserted when external space area 5 is accessed
	1	1 program wait state inserted when external space area 5 is accessed
1	0	2 program wait states inserted when external space area 5 is accessed
	1	3 program wait states inserted when external space area 5 is accessed (Initial value)

Bits 1 and 0—Area 4 Wait Control 1 and 0 (W41, W40): These bits select the number of program wait states when area 4 in external space is accessed while the AST4 bit in ASTCR is set to 1.

Bit 1	Bit 0	
W41	W40	Description
0	0	Program wait not inserted when external space area 4 is accessed
	1	1 program wait state inserted when external space area 4 is accessed
1	0	2 program wait states inserted when external space area 4 is accessed
	1	3 program wait states inserted when external space area 4 is accessed (Initial value)

(2) WCRL

Bit	:	7	6	5	4	3	2	1	0
		W31	W30	W21	W20	W11	W10	W01	W00
Initial value	:	1	1	1	1	1	1	1	1
R/W	:	R/W	R/W	R/W	R/W	R/W	R/W	R/W	R/W

Bits 7 and 6—Area 3 Wait Control 1 and 0 (W31, W30): These bits select the number of program wait states when area 3 in external space is accessed while the AST3 bit in ASTCR is set to 1.

Bit 7	Bit 6	
W31	W30	Description
0	0	Program wait not inserted when external space area 3 is accessed
	1	1 program wait state inserted when external space area 3 is accessed
1	0	2 program wait states inserted when external space area 3 is accessed
	1	3 program wait states inserted when external space area 3 is accessed (Initial value)

Bits 5 and 4—Area 2 Wait Control 1 and 0 (W21, W20): These bits select the number of program wait states when area 2 in external space is accessed while the AST2 bit in ASTCR is set to 1.

Bit 5	Bit 4	
W21	W20	Description
0	0	Program wait not inserted when external space area 2 is accessed
	1	1 program wait state inserted when external space area 2 is accessed
1	0	2 program wait states inserted when external space area 2 is accessed
	1	3 program wait states inserted when external space area 2 is accessed (Initial value)

Bits 3 and 2—Area 1 Wait Control 1 and 0 (W11, W10): These bits select the number of program wait states when area 1 in external space is accessed while the AST1 bit in ASTCR is set to 1.

Bit 3	Bit 2	Description
W11	W10	
0	0	Program wait not inserted when external space area 1 is accessed
	1	1 program wait state inserted when external space area 1 is accessed
1	0	2 program wait states inserted when external space area 1 is accessed
	1	3 program wait states inserted when external space area 1 is accessed (Initial value)

Bits 1 and 0—Area 0 Wait Control 1 and 0 (W01, W00): These bits select the number of program wait states when area 0 in external space is accessed while the AST0 bit in ASTCR is set to 1.

Bit 1	Bit 0	Description
W01	W00	
0	0	Program wait not inserted when external space area 0 is accessed
	1	1 program wait state inserted when external space area 0 is accessed
1	0	2 program wait states inserted when external space area 0 is accessed
	1	3 program wait states inserted when external space area 0 is accessed (Initial value)

6.2.4 Bus Control Register H (BCRH)

Bit	:	7	6	5	4	3	2	1	0
		ICIS1	ICIS0	BRSTRM	BRSTS1	BRSTS0	—	—	—
Initial value	:	1	1	0	1	0	0	0	0
R/W	:	R/W	R/W	R/W	R/W	R/W	R/W	R/W	R/W

BCRH is an 8-bit readable/writable register that selects enabling or disabling of idle cycle insertion, and the memory interface for areas 2 to 5 and area 0.

BCRH is initialized to H'D0 by a power-on reset and in hardware standby mode. It is not initialized by a manual reset or in software standby mode.

Bit 7—Idle Cycle Insert 1 (ICIS1): Selects whether or not one idle cycle state is to be inserted between bus cycles when successive external read cycles are performed in different areas.

Bit 7

ICIS1	Description
0	Idle cycle not inserted in case of successive external read cycles in different areas
1	Idle cycle inserted in case of successive external read cycles in different areas (Initial value)

Bit 6—Idle Cycle Insert 0 (ICIS0): Selects whether or not one idle cycle state is to be inserted between bus cycles when successive external read and external write cycles are performed .

Bit 6

ICIS0	Description
0	Idle cycle not inserted in case of successive external read and external write cycles
1	Idle cycle inserted in case of successive external read and external write cycles (Initial value)

Bit 5—Burst ROM Enable (BRSTRM): Selects whether area 0 is used as a burst ROM interface. In normal mode, the selection can be made from the entire external space .

Bit 5

BRSTRM	Description
0	Area 0 is basic bus interface (Initial value)
1	Area 0 is burst ROM interface

Bit 4—Burst Cycle Select 1 (BRSTS1): Selects the number of burst cycles for the burst ROM interface.

Bit 4

BRSTS1	Description
0	Burst cycle comprises 1 state
1	Burst cycle comprises 2 states (Initial value)

Bit 3—Burst Cycle Select 0 (BRSTS0): Selects the number of words that can be accessed in a burst ROM interface burst access.

Bit 3

BRSTS0	Description	
0	Max. 4 words in burst access	(Initial value)
1	Max. 8 words in burst access	

Bits 2 to 0—Reserved: Only 0 should be written to these bits.

6.2.5 Bus Control Register L (BCRL)

Bit	:	7	6	5	4	3	2	1	0
		BRLE	—	EAE	—	—	—	—	WAITE
Initial value :		0	0	1	1	1	1	0	0
R/W :		R/W	R/W	R/W	R/W	R/W	R/W	R/W	R/W

BCRL is an 8-bit readable/writable register that performs selection of the external bus-released state protocol, and enabling or disabling of $\overline{\text{WAIT}}$ pin input.

BCRL is initialized to H'3C by a power-on reset and in hardware standby mode. It is not initialized by a manual reset or in software standby mode.

Bit 7—Bus Release Enable (BRLE): Enables or disables external bus release.

Bit 7

BRLE	Description	
0	External bus release is disabled. $\overline{\text{BREQ}}$ and $\overline{\text{BACK}}$ can be used as I/O ports.	(Initial value)
1	External bus release is enabled.	

Bit 6—Reserved: Only 0 should be written to this bit.

Bit 5—External Address Enable (EAE): Selects whether addresses H'010000 to H'01FFFF are to be internal addresses or external addresses.

This setting is invalid in normal mode.

Bit 5

EAE	Description
0	Addresses H'010000 to H'01FFFF are in on-chip ROM (in the H8S/2355) or a reserved area* (in the H8S/2353)
1	Addresses H'010000 to H'01FFFF are external addresses (external expansion mode) or a reserved area* (single-chip mode) (Initial value)

Note: * Reserved areas should not be accessed.

Bits 4 to 2—Reserved: Only 1 should be written to these bits.

Bit 1—Reserved: Only 0 should be written to this bit.

Bit 0—WAIT Pin Enable (WAITE): Selects enabling or disabling of wait input by the $\overline{\text{WAIT}}$ pin.

Bit 0

WAITE	Description
0	Wait input by $\overline{\text{WAIT}}$ pin disabled. $\overline{\text{WAIT}}$ pin can be used as I/O port. (Initial value)
1	Wait input by $\overline{\text{WAIT}}$ pin enabled

6.3 Overview of Bus Control

6.3.1 Area Partitioning

In advanced mode, the bus controller partitions the 16 Mbytes address space into eight areas, 0 to 7, in 2-Mbyte units, and performs bus control for external space in area units. In normal mode, it controls a 64-kbyte address space comprising part of area 0. Figure 6-2 shows an outline of the memory map.

Chip select signals ($\overline{\text{CS0}}$ to $\overline{\text{CS7}}$) can be output for each area.

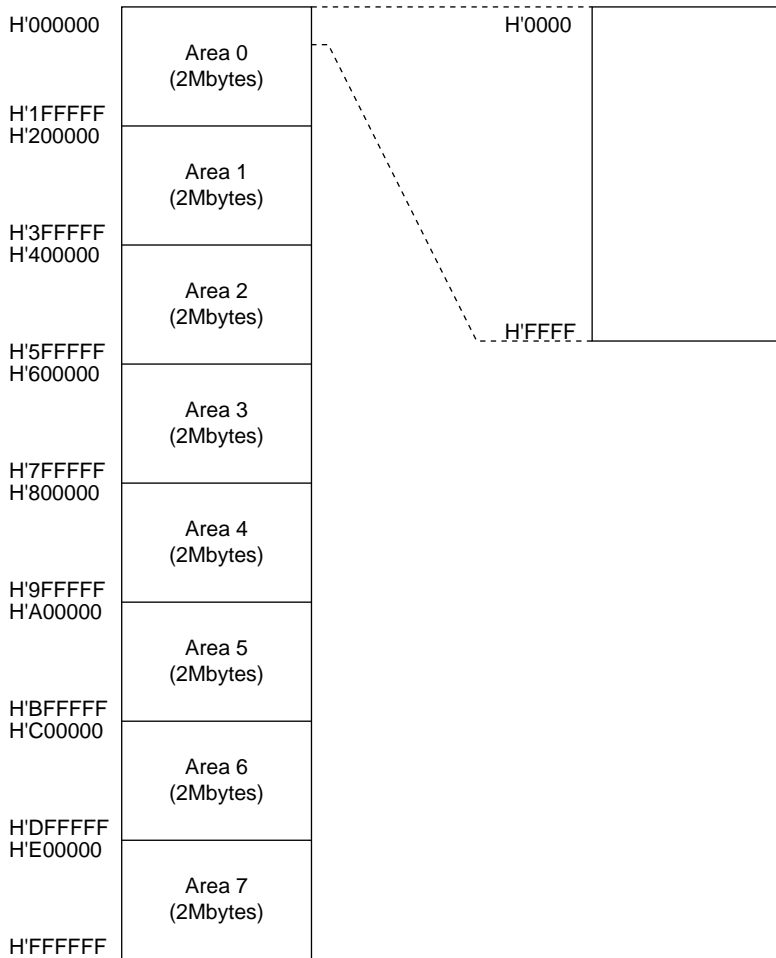

(1) Advanced mode

(2) Normal mode

Figure 6-2 Overview of Area Partitioning

6.3.2 Bus Specifications

The external space bus specifications consist of three elements: bus width, number of access states, and number of program wait states.

The bus width and number of access states for on-chip memory and internal I/O registers are fixed, and are not affected by the bus controller.

(1) Bus Width: A bus width of 8 or 16 bits can be selected with ADWCR. An area for which an 8-bit bus is selected functions as an 8-bit access space, and an area for which a 16-bit bus is selected functions as a 16-bit access space.

If all areas are designated for 8-bit access, 8-bit bus mode is set; if any area is designated for 16-bit access, 16-bit bus mode is set. When the burst ROM interface is designated, 16-bit bus mode is always set.

(2) Number of Access States: Two or three access states can be selected with ASTCR. An area for which 2-state access is selected functions as a 2-state access space, and an area for which 3-state access is selected functions as a 3-state access space.

With the burst ROM interface, the number of access states may be determined without regard to ASTCR.

When 2-state access space is designated, wait insertion is disabled.

(3) Number of Program Wait States: When 3-state access space is designated by ASTCR, the number of program wait states to be inserted automatically is selected with WCRH and WCRL. From 0 to 3 program wait states can be selected.

Table 6-3 shows the bus specifications for each basic bus interface area.

Table 6-3 Bus Specifications for Each Area (Basic Bus Interface)

ABWCR	ASTCR	WCRH, WCRL		Bus Specifications (Basic Bus Interface)		
ABWn	ASTn	Wn1	Wn0	Bus Width	Access States	Program Wait States
0	0	—	—	16	2	0
	1	0	0		3	0
			1		1	
			0		2	
			1		3	
1	0	—	—	8	2	0
	1	0	0		3	0
			1		1	
			0		2	
			1		3	

6.3.3 Memory Interfaces

The H8S/2355 Series memory interfaces comprise a basic bus interface that allows direct connection of ROM, SRAM, and so on, and a burst ROM interface (for area 0 only) that allows direct connection of burst ROM.

An area for which the basic bus interface is designated functions as normal space, and an area for which the burst ROM interface is designated functions as burst ROM space.

6.3.4 Advanced Mode

The initial state of each area is basic bus interface, 3-state access space. The initial bus width is selected according to the operating mode. The bus specifications described here cover basic items only, and the sections on each memory interface (6.4 and 6.5) should be referred to for further details.

Area 0: Area 0 includes on-chip ROM, and in ROM-disabled expansion mode, all of area 0 is external space. In ROM-enabled expansion mode, the space excluding on-chip ROM is external space.

When area 0 external space is accessed, the $\overline{CS0}$ signal can be output.

Either basic bus interface or burst ROM interface can be selected for area 0.

Areas 1 to 6: In external expansion mode, all of areas 1 to 6 is external space.

When area 1 to 6 external space is accessed, the $\overline{CS1}$ to $\overline{CS6}$ pin signals respectively can be output.

Only the basic bus interface can be used for areas 1 to 6.

Area 7: Area 7 includes the on-chip RAM and internal I/O registers. In external expansion mode, the space excluding the on-chip RAM and internal I/O registers is external space. The on-chip RAM is enabled when the RAME bit in the system control register (SYSCR) is set to 1; when the RAME bit is cleared to 0, the on-chip RAM is disabled and the corresponding space becomes external space.

When area 7 external space is accessed, the $\overline{CS7}$ signal can be output.

Only the basic bus interface can be used for the area 7 memory interface.

6.3.5 Areas in Normal Mode

In normal mode, a 64-kbyte address space comprising part of area 0 is controlled. Area partitioning is not performed in normal mode. In ROM-disabled expansion mode, the space excluding the on-chip RAM and internal I/O registers is external space. In ROM-enabled expansion mode the space excluding the on-chip ROM, on-chip RAM, and internal I/O registers is external space. The on-chip RAM is enabled when the RAME bit in the system control register (SYSCR) is set to 1; when the RAME bit is cleared to 0, the on-chip RAM is disabled and the corresponding space becomes external space .

When external space is accessed, the $\overline{CS0}$ signal can be output.

The basic bus interface or burst ROM interface can be selected.

6.3.6 Chip Select Signals

The H8S/2355 Series can output chip select signals ($\overline{CS0}$ to $\overline{CS7}$) to areas 0 to 7, the signal being driven low when the corresponding external space area is accessed. In normal mode, only the $\overline{CS0}$ signal can be output.

Figure 6-3 shows an example of \overline{CSn} ($n = 0$ to 7) output timing.

Enabling or disabling of the \overline{CSn} signal is performed by setting the data direction register (DDR) for the port corresponding to the particular \overline{CSn} pin.

In ROM-disabled expansion mode, the $\overline{CS0}$ pin is placed in the output state after a power-on reset. Pins $\overline{CS1}$ to $\overline{CS7}$ are placed in the input state after a power-on reset, and so the corresponding DDR should be set to 1 when outputting signals $\overline{CS1}$ to $\overline{CS7}$.

In ROM-enabled expansion mode, pins $\overline{CS0}$ to $\overline{CS7}$ are all placed in the input state after a power-on reset, and so the corresponding DDR should be set to 1 when outputting signals $\overline{CS0}$ to $\overline{CS7}$.

For details, see section 8, I/O Ports.

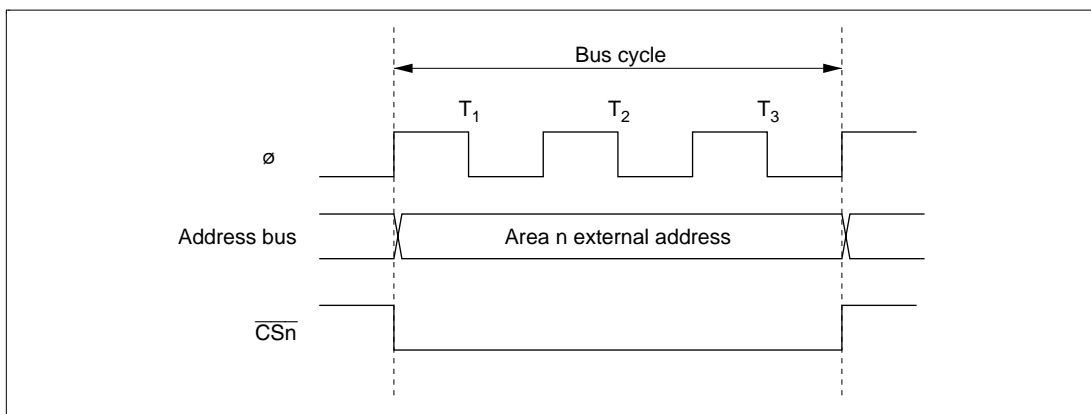

Figure 6-3 \overline{CSn} Signal Output Timing ($n = 0$ to 7)

6.4 Basic Bus Interface

6.4.1 Overview

The basic bus interface enables direct connection of ROM, SRAM, and so on.

The bus specifications can be selected with ABWCR, ASTCR, WCRH, and WCRL (see table 6-3).

6.4.2 Data Size and Data Alignment

Data sizes for the CPU and other internal bus masters are byte, word, and longword. The bus controller has a data alignment function, and when accessing external space, controls whether the upper data bus (D_{15} to D_8) or lower data bus (D_7 to D_0) is used according to the bus specifications for the area being accessed (8-bit access space or 16-bit access space) and the data size.

8-Bit Access Space: Figure 6-4 illustrates data alignment control for the 8-bit access space. With the 8-bit access space, the upper data bus (D_{15} to D_8) is always used for accesses. The amount of data that can be accessed at one time is one byte: a word transfer instruction is performed as two byte accesses, and a longword transfer instruction, as four byte accesses.

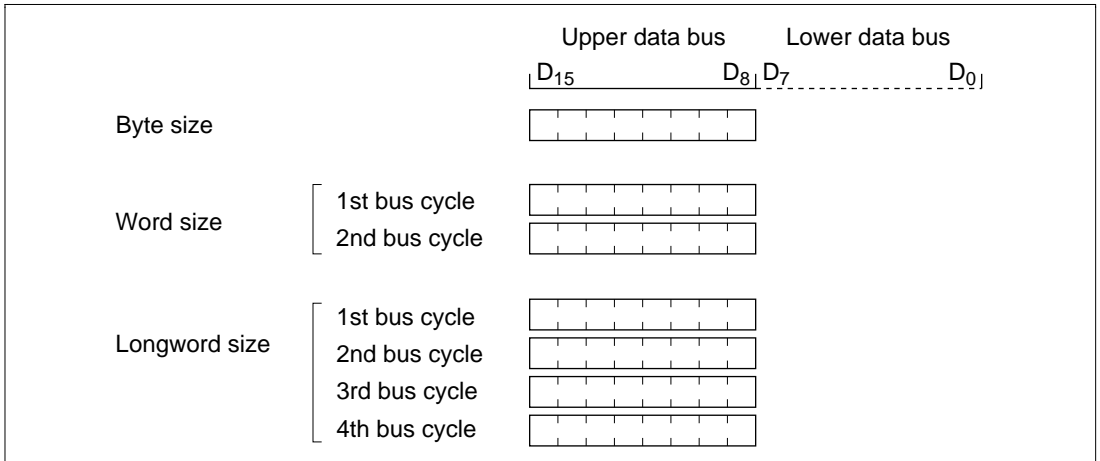

Figure 6-4 Access Sizes and Data Alignment Control (8-Bit Access Space)

16-Bit Access Space: Figure 6-5 illustrates data alignment control for the 16-bit access space. With the 16-bit access space, the upper data bus (D_{15} to D_8) and lower data bus (D_7 to D_0) are used for accesses. The amount of data that can be accessed at one time is one byte or one word, and a longword transfer instruction is executed as two word transfer instructions.

In byte access, whether the upper or lower data bus is used is determined by whether the address is even or odd. The upper data bus is used for an even address, and the lower data bus for an odd address.

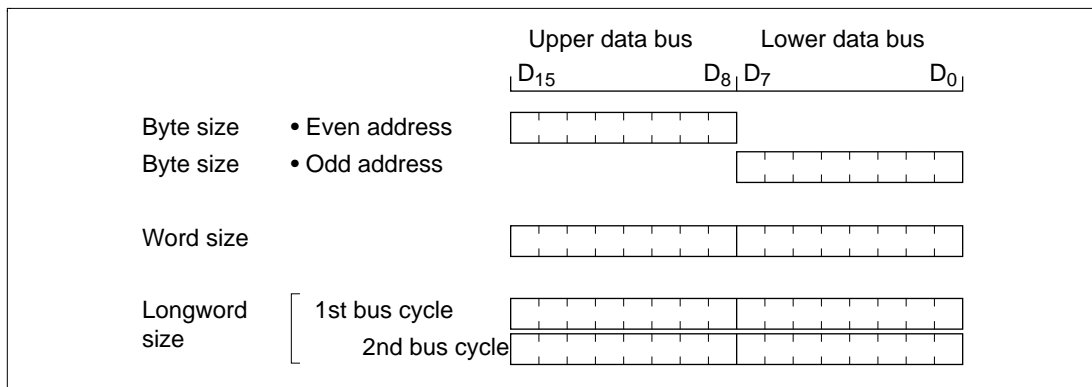

Figure 6-5 Access Sizes and Data Alignment Control (16-Bit Access Space)

6.4.3 Valid Strobes

Table 6-4 shows the data buses used and valid strobes for the access spaces.

In a read, the \overline{RD} signal is valid without discrimination between the upper and lower halves of the data bus.

In a write, the \overline{HWR} signal is valid for the upper half of the data bus, and the \overline{LWR} signal for the lower half.

Table 6-4 Data Buses Used and Valid Strobes

Area	Access Size	Read/Write	Address	Valid Strobe	Upper Data Bus (D ₁₅ to D ₈)	Lower data bus (D ₇ to D ₀)
8-bit access space	Byte	Read	—	\overline{RD}	Valid	Invalid
		Write	—	\overline{HWR}		Hi-Z
16-bit access space	Byte	Read	Even	\overline{RD}	Valid	Invalid
			Odd		Invalid	Valid
	Write	Even	\overline{HWR}	Valid	Hi-Z	
		Odd	\overline{LWR}	Hi-Z	Valid	
Word	Read	—	—	\overline{RD}	Valid	Valid
						Write

Note: Hi-Z: High impedance.

Invalid: Input state; input value is ignored.

6.4.4 Basic Timing

8-Bit 2-State Access Space: Figure 6-6 shows the bus timing for an 8-bit 2-state access space. When an 8-bit access space is accessed, the upper half (D_{15} to D_8) of the data bus is used.

The \overline{LWR} pin is fixed high. Wait states cannot be inserted.

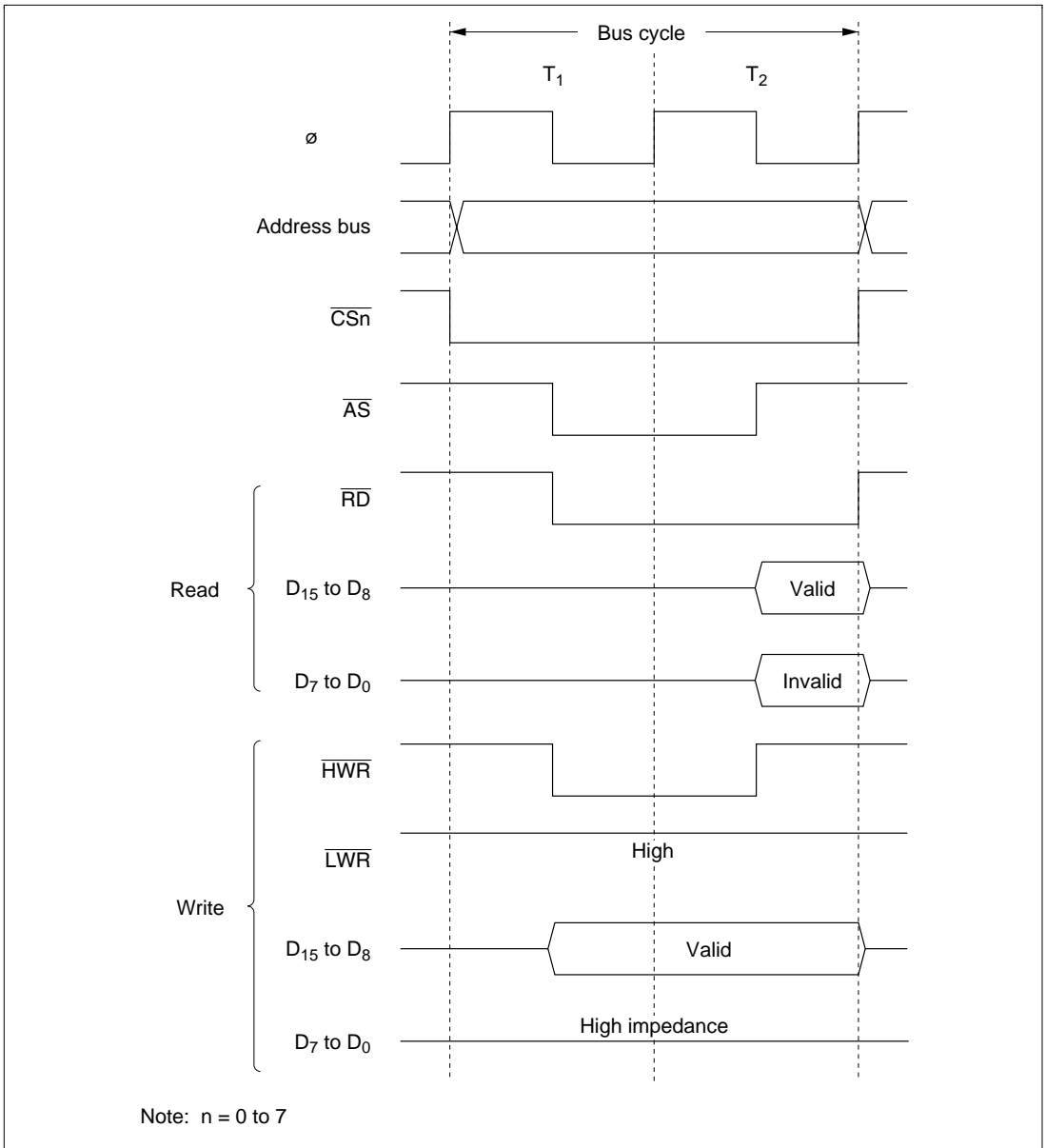

Figure 6-6 Bus Timing for 8-Bit 2-State Access Space

8-Bit 3-State Access Space: Figure 6-7 shows the bus timing for an 8-bit 3-state access space. When an 8-bit access space is accessed, the upper half (D_{15} to D_8) of the data bus is used.

The \overline{LWR} pin is fixed high. Wait states can be inserted.

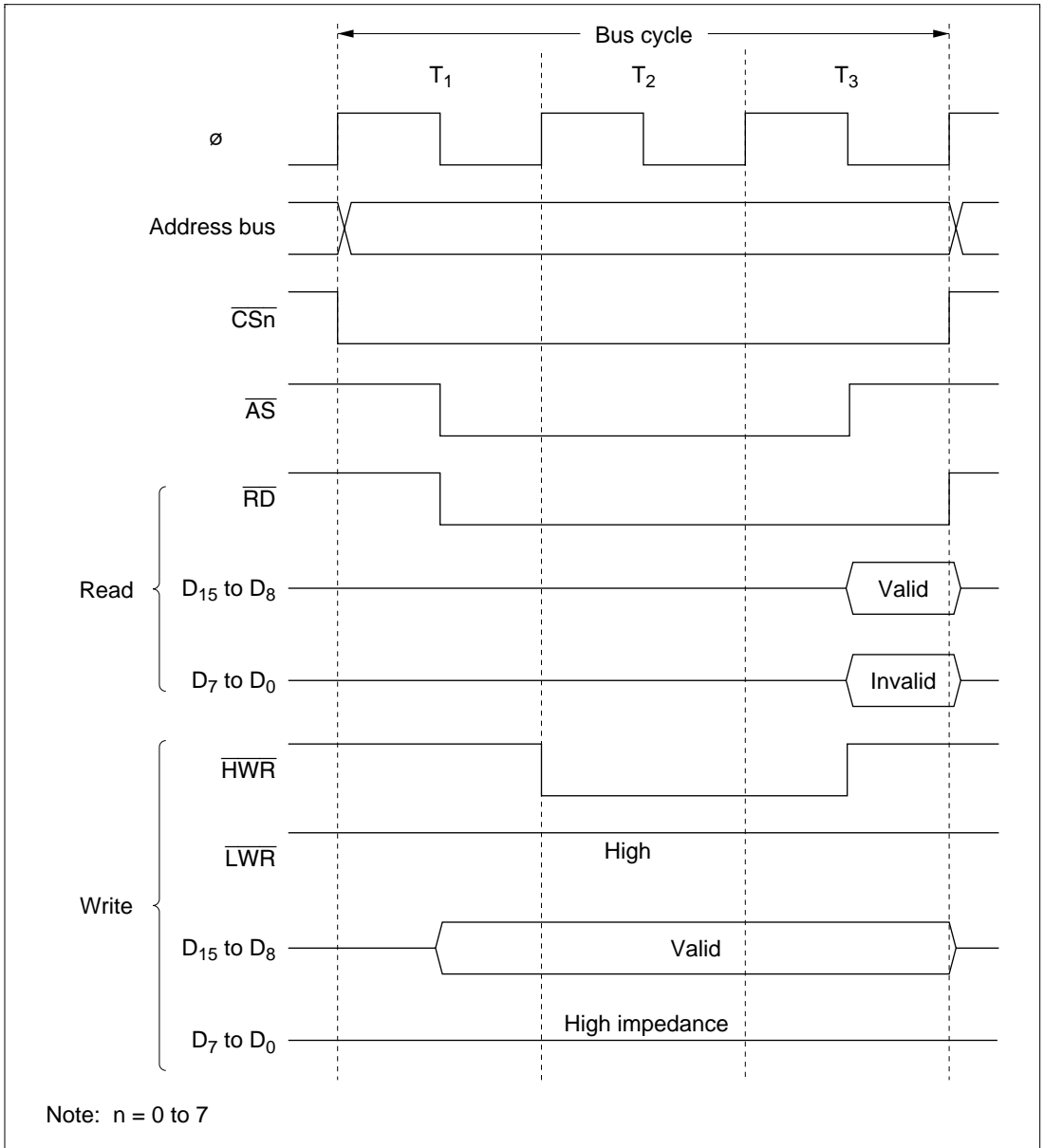

Figure 6-7 Bus Timing for 8-Bit 3-State Access Space

16-Bit 2-State Access Space: Figures 6-8 to 6-10 show bus timings for a 16-bit 2-state access space. When a 16-bit access space is accessed, the upper half (D_{15} to D_8) of the data bus is used for the even address, and the lower half (D_7 to D_0) for the odd address.

Wait states cannot be inserted.

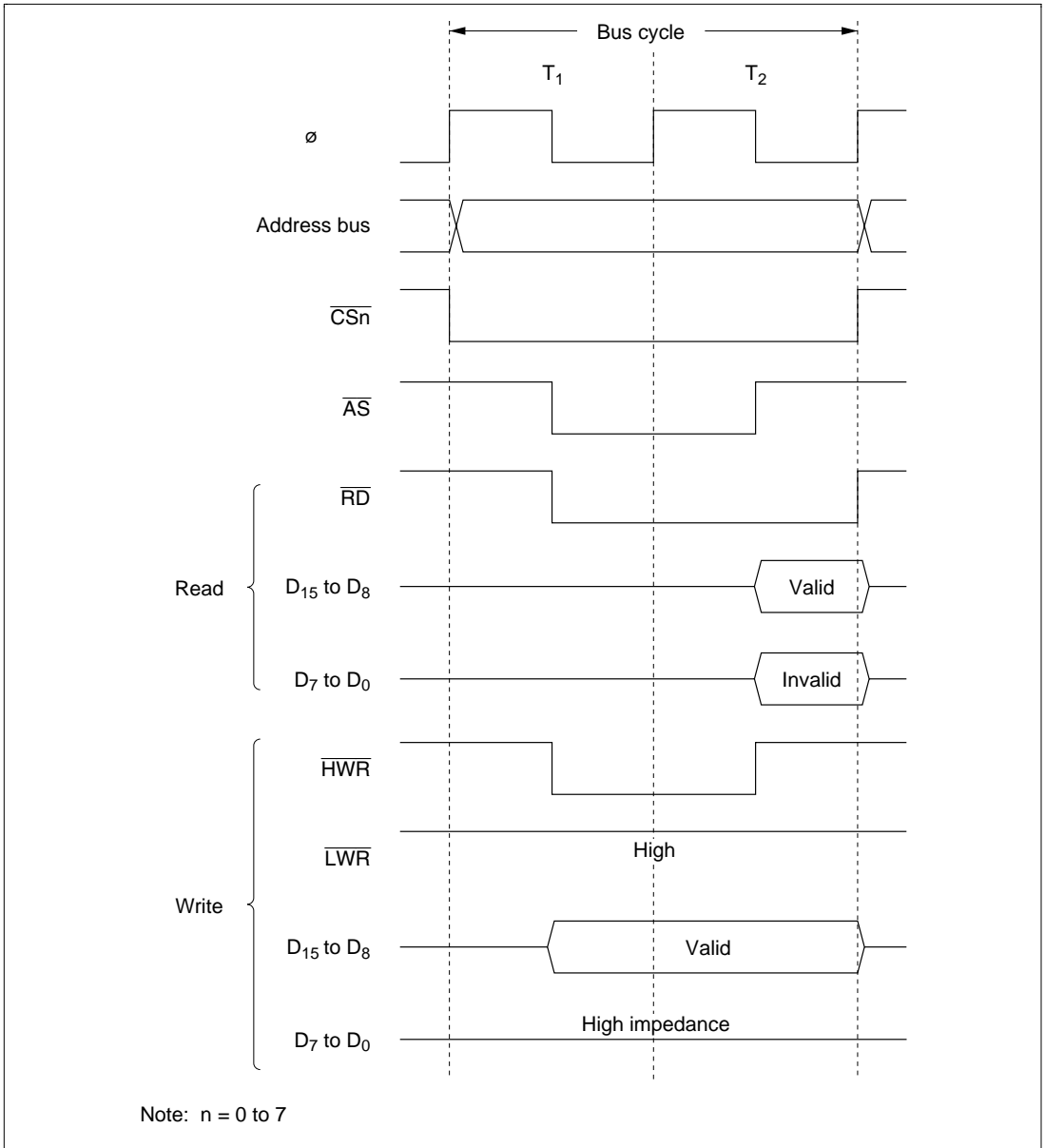
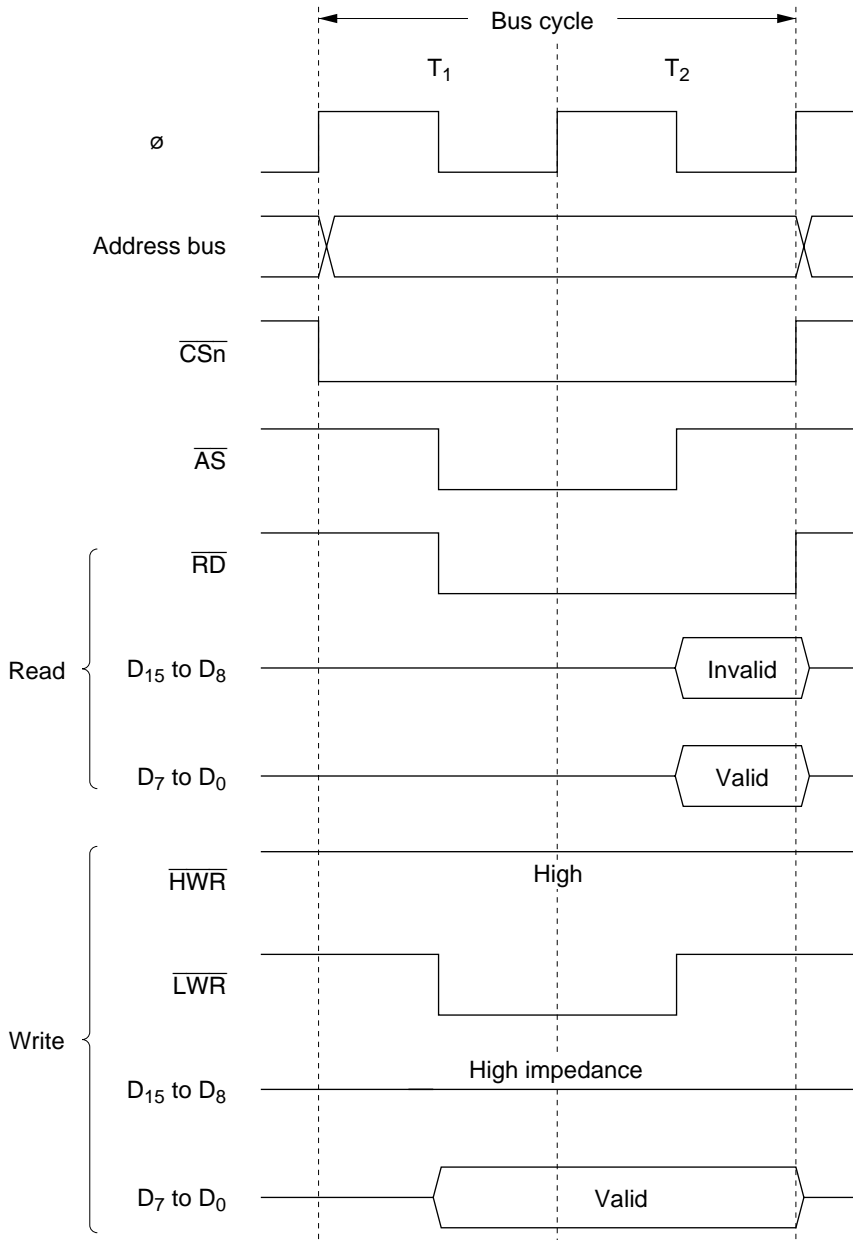
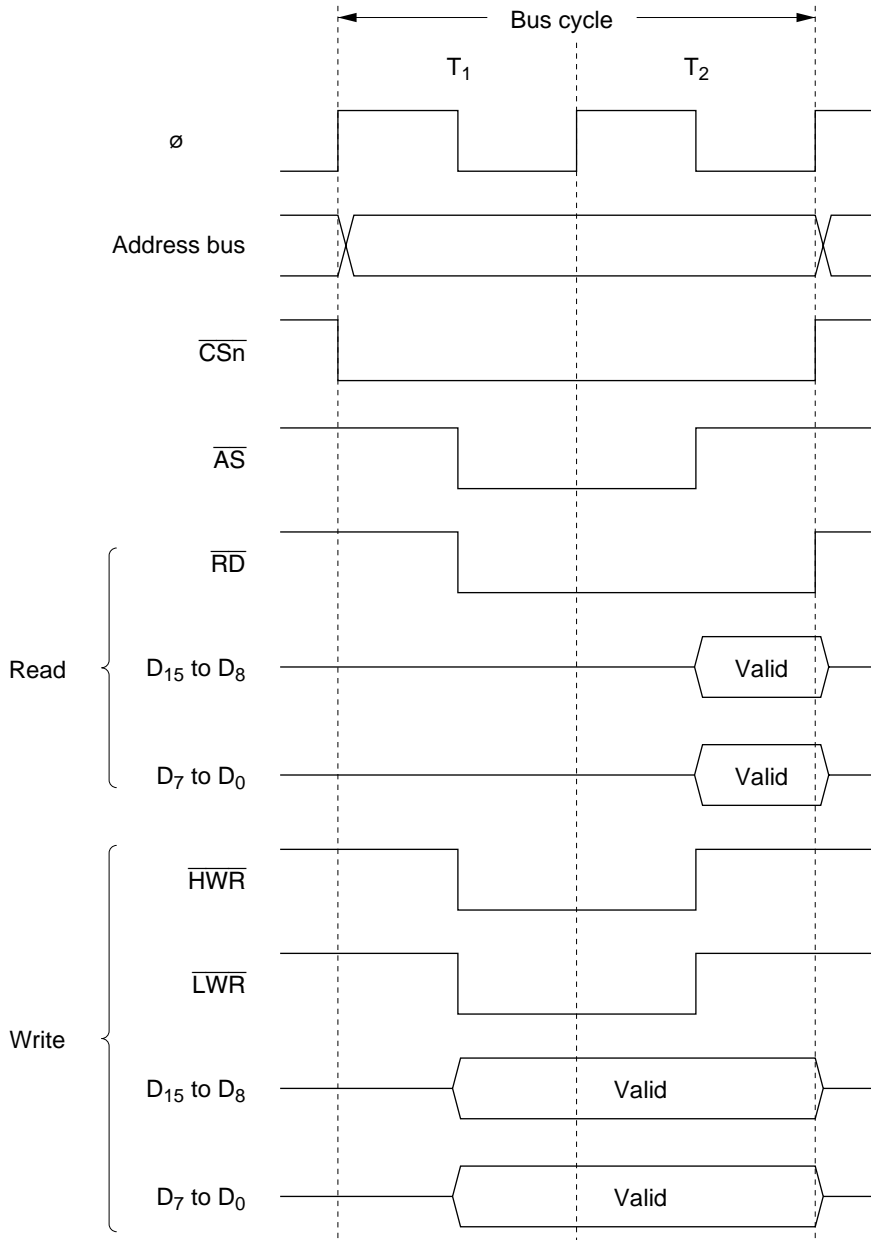

Figure 6-8 Bus Timing for 16-Bit 2-State Access Space (1) (Even Address Byte Access)



Note: $n = 0$ to 7

Figure 6-9 Bus Timing for 16-Bit 2-State Access Space (2) (Odd Address Byte Access)



Note: $n = 0$ to 7

Figure 6-10 Bus Timing for 16-Bit 2-State Access Space (3) (Word Access)

16-Bit 3-State Access Space: Figures 6-11 to 6-13 show bus timings for a 16-bit 3-state access space. When a 16-bit access space is accessed, the upper half (D_{15} to D_8) of the data bus is used for the even address, and the lower half (D_7 to D_0) for the odd address.

Wait states can be inserted.

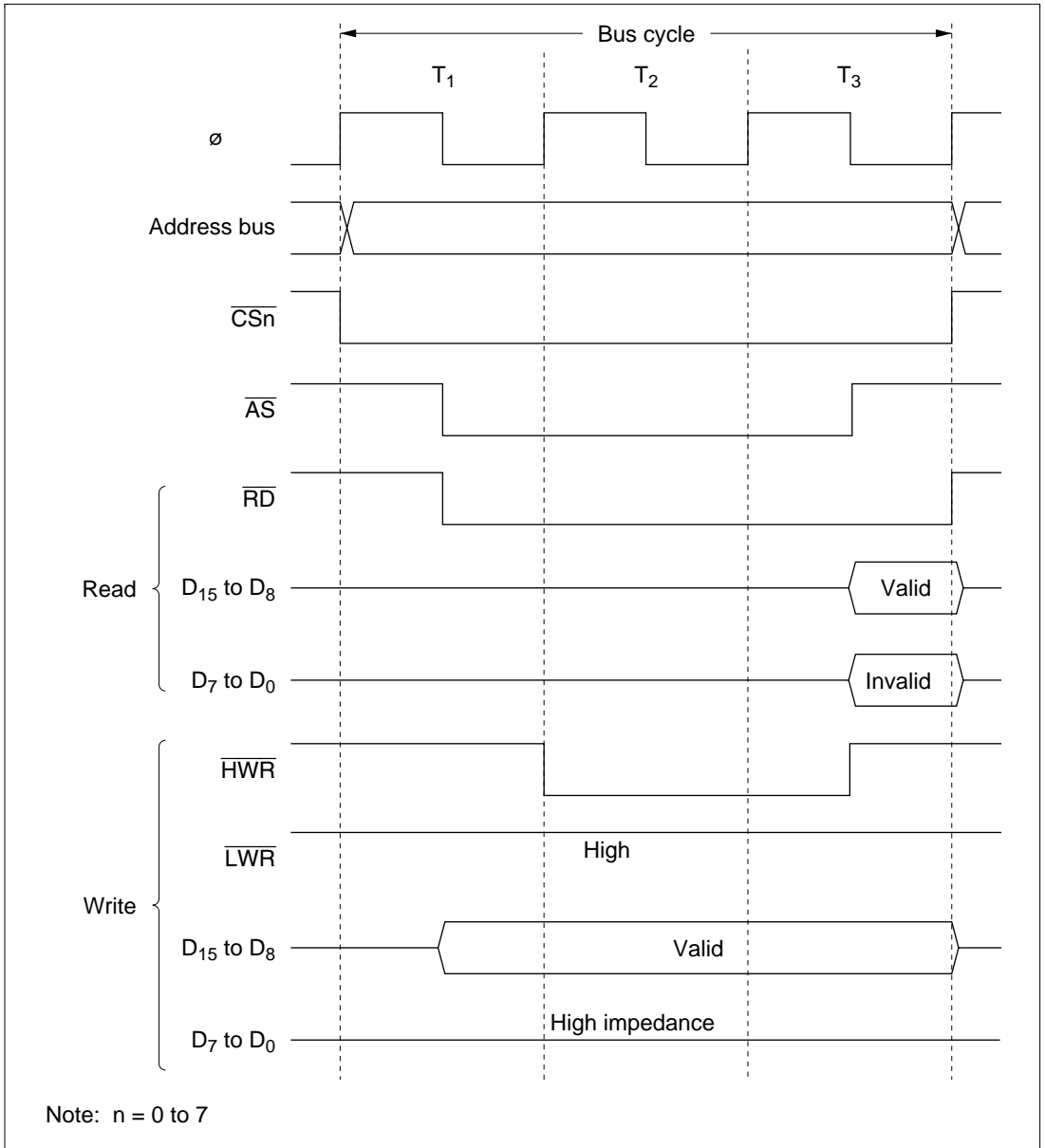
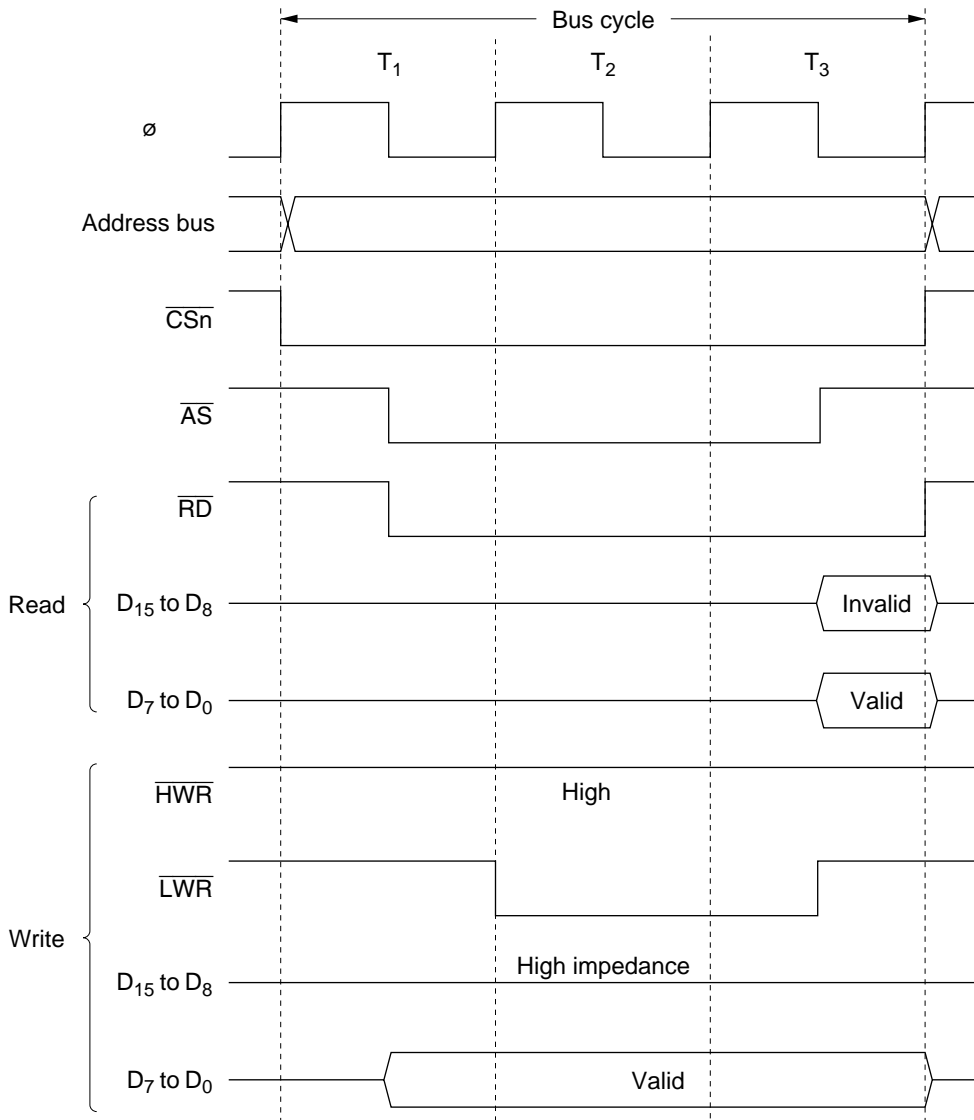

Figure 6-11 Bus Timing for 16-Bit 3-State Access Space (1) (Even Address Byte Access)



Note: n = 0 to 7

Figure 6-12 Bus Timing for 16-Bit 3-State Access Space (2) (Odd Address Byte Access)

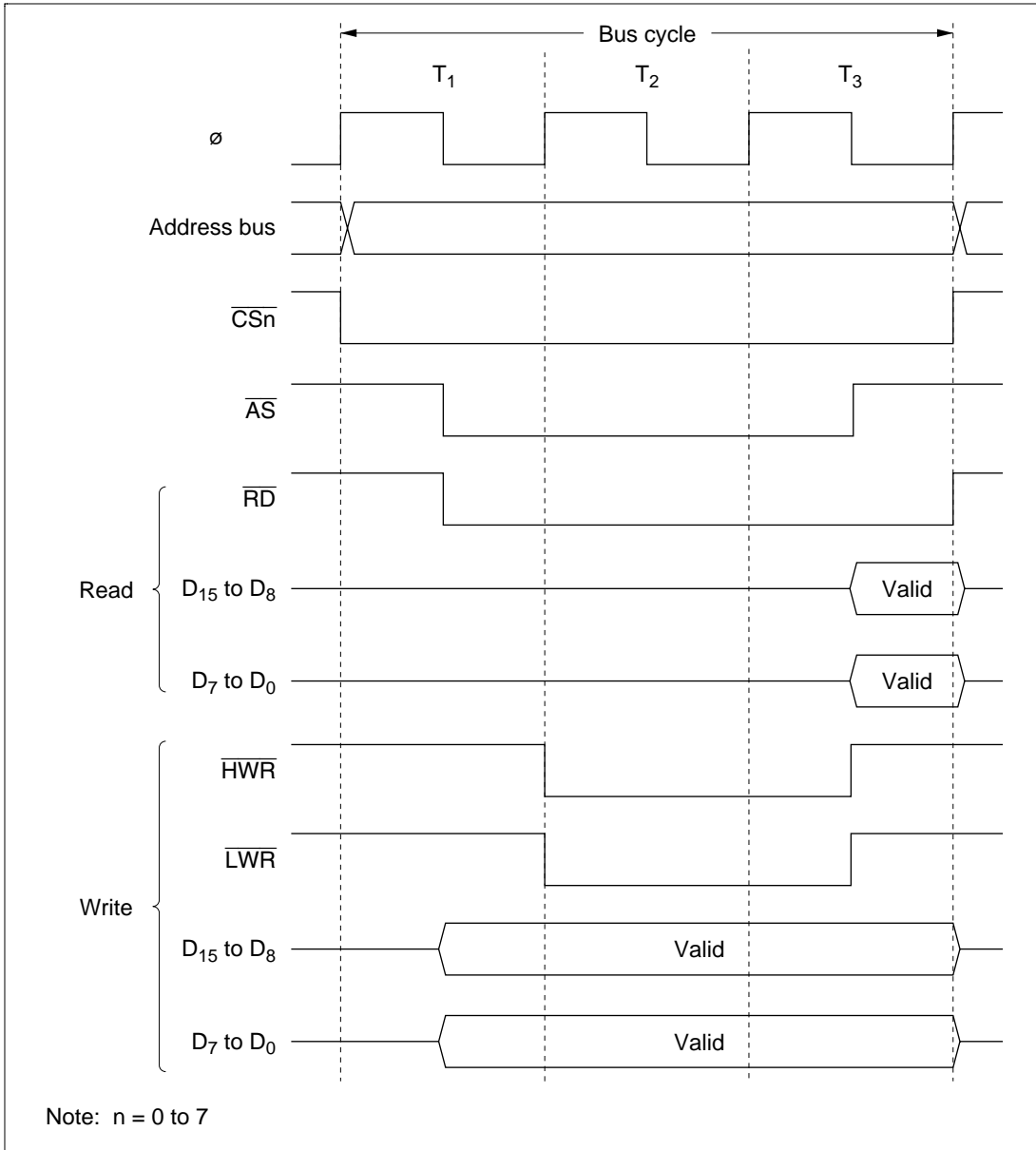

Figure 6-13 Bus Timing for 16-Bit 3-State Access Space (3) (Word Access)

6.4.5 Wait Control

When accessing external space, the H8S/2355 Series can extend the bus cycle by inserting one or more wait states (T_w). There are two ways of inserting wait states: program wait insertion and pin wait insertion using the $\overline{\text{WAIT}}$ pin.

Program Wait Insertion

From 0 to 3 wait states can be inserted automatically between the T_2 state and T_3 state on an individual area basis in 3-state access space, according to the settings of BWCRH and BWCRL.

Pin Wait Insertion

Setting the WAITE bit in BCRL to 1 enables wait insertion by means of the $\overline{\text{WAIT}}$ pin. Program wait insertion is first carried out according to the settings in WCRH and WCRL. Then, if the $\overline{\text{WAIT}}$ pin is low at the falling edge of ϕ in the last T_2 or T_w state, a T_w state is inserted. If the $\overline{\text{WAIT}}$ pin is held low, T_w states are inserted until it goes high.

This is useful when inserting four or more T_w states, or when changing the number of T_w states for different external devices.

The WAITE bit setting applies to all areas.

Figure 6-14 shows an example of wait state insertion timing.

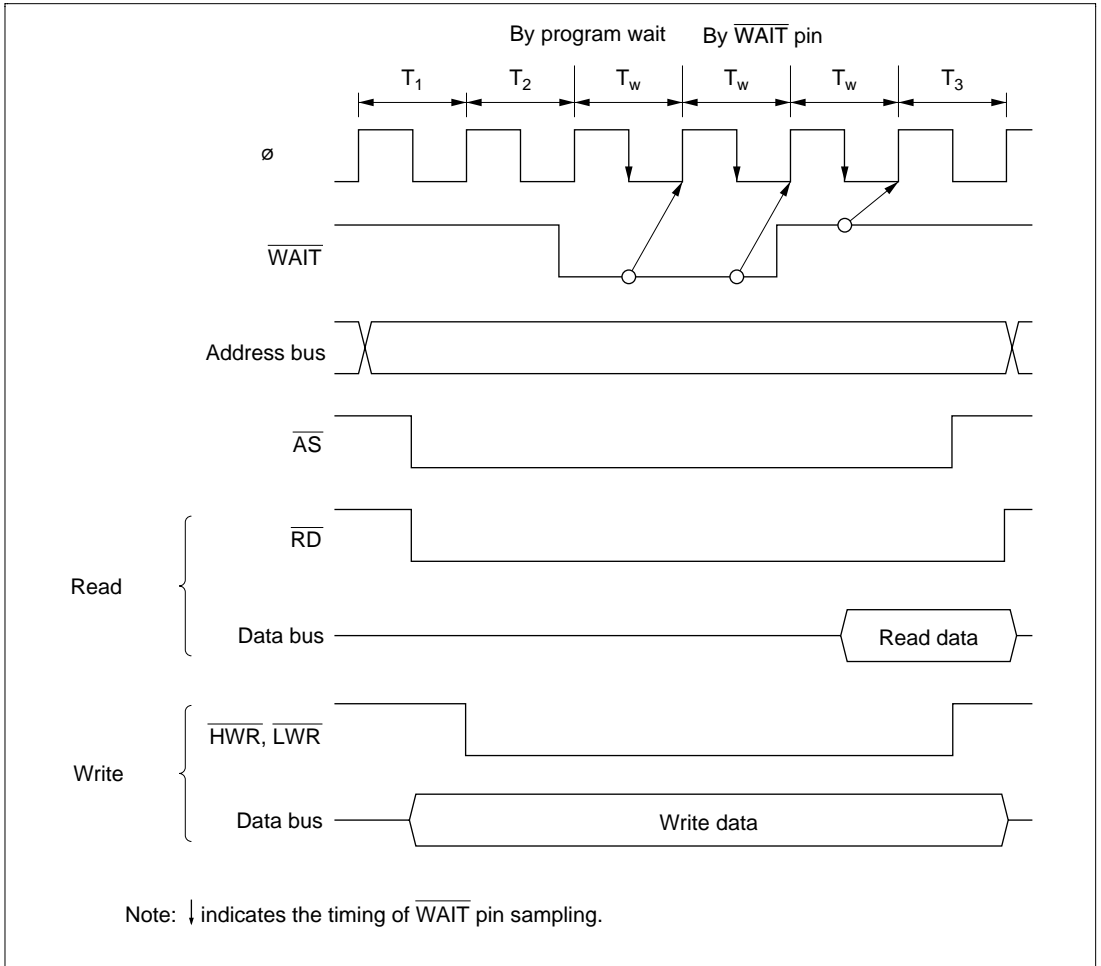

Figure 6-14 Example of Wait State Insertion Timing

The settings after a power-on reset are: 3-state access, 3 program wait state insertion, and $\overline{\text{WAIT}}$ input disabled. When a manual reset is performed, the contents of bus controller registers are retained, and the wait control settings remain the same as before the reset.

6.5 Burst ROM Interface

6.5.1 Overview

With the H8S/2355 Series, external space area 0 can be designated as burst ROM space, and burst ROM interfacing can be performed. The burst ROM space interface enables 16-bit configuration ROM with burst access capability to be accessed at high speed.

Area 0 can be designated as burst ROM space by means of the BRSTRM bit in BCRH. Consecutive burst accesses of a maximum of 4 words or 8 words can be performed for CPU instruction fetches only. One or two states can be selected for burst access.

6.5.2 Basic Timing

The number of states in the initial cycle (full access) of the burst ROM interface is in accordance with the setting of the AST0 bit in ASTCR. Also, when the AST0 bit is set to 1, wait state insertion is possible. One or two states can be selected for the burst cycle, according to the setting of the BRSTS1 bit in BCRH. Wait states cannot be inserted. When area 0 is designated as burst ROM space, it becomes 16-bit access space regardless of the setting of the ABW0 bit in ABWCR.

When the BRSTS0 bit in BCRH is cleared to 0, burst access of up to 4 words is performed; when the BRSTS0 bit is set to 1, burst access of up to 8 words is performed.

The basic access timing for burst ROM space is shown in figures 6-15 (a) and (b). The timing shown in figure 6-15 (a) is for the case where the AST0 and BRSTS1 bits are both set to 1, and that in figure 6-15 (b) is for the case where both these bits are cleared to 0.

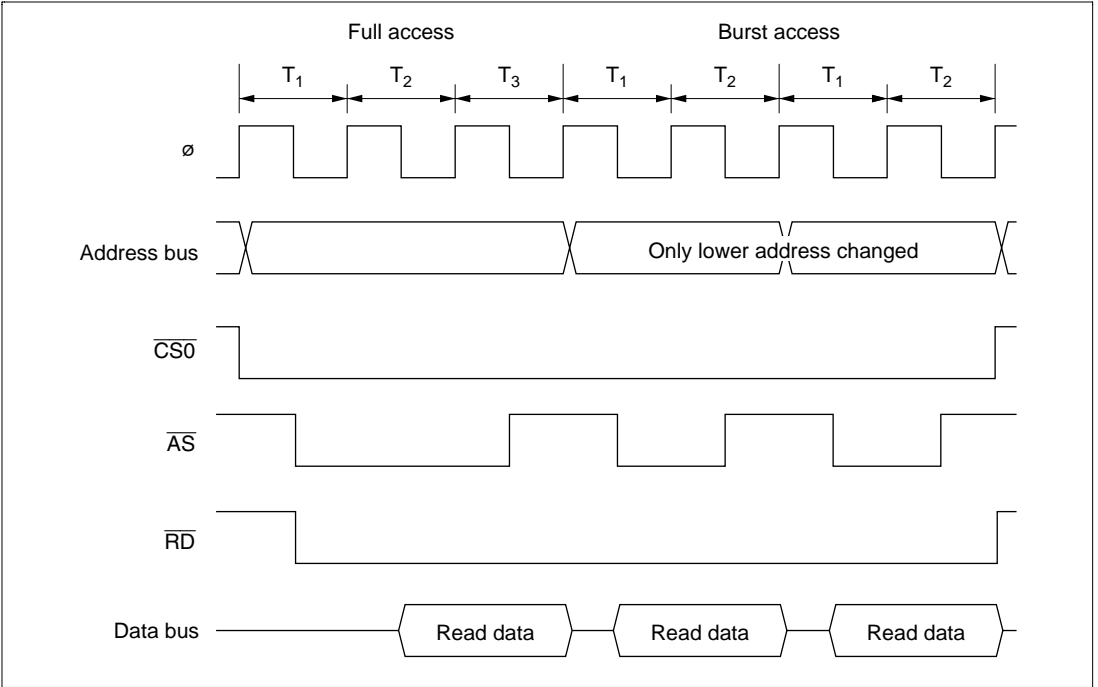

Figure 6-15 (a) Example of Burst ROM Access Timing (When $AST0 = BRSTS1 = 1$)

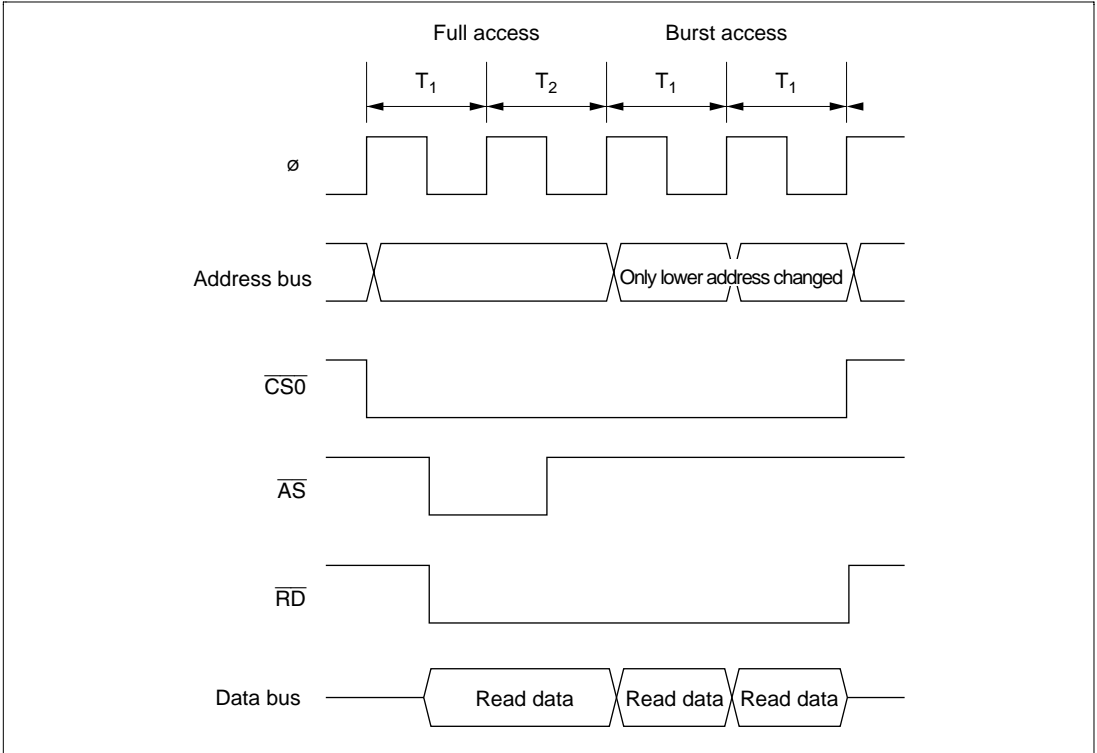

Figure 6-15 (b) Example of Burst ROM Access Timing (When $AST0 = BRSTS1 = 0$)

6.5.3 Wait Control

As with the basic bus interface, either program wait insertion or pin wait insertion using the \overline{WAIT} pin can be used in the initial cycle (full access) of the burst ROM interface. See section 6.4.5, Wait Control.

Wait states cannot be inserted in a burst cycle.

6.6 Idle Cycle

6.6.1 Operation

When the H8S/2355 Series accesses external space, it can insert a 1-state idle cycle (T_1) between bus cycles in the following two cases: (1) when read accesses between different areas occur consecutively, and (2) when a write cycle occurs immediately after a read cycle. By inserting an idle cycle it is possible, for example, to avoid data collisions between ROM, with a long output floating time, and high-speed memory, I/O interfaces, and so on.

(1) Consecutive Reads between Different Areas

If consecutive reads between different areas occur while the ICIS1 bit in BCRH is set to 1, an idle cycle is inserted at the start of the second read cycle. This is enabled in advanced mode.

Figure 6-16 shows an example of the operation in this case. In this example, bus cycle A is a read cycle from ROM with a long output floating time, and bus cycle B is a read cycle from SRAM, each being located in a different area. In (a), an idle cycle is not inserted, and a collision occurs in cycle B between the read data from ROM and that from SRAM. In (b), an idle cycle is inserted, and a data collision is prevented.

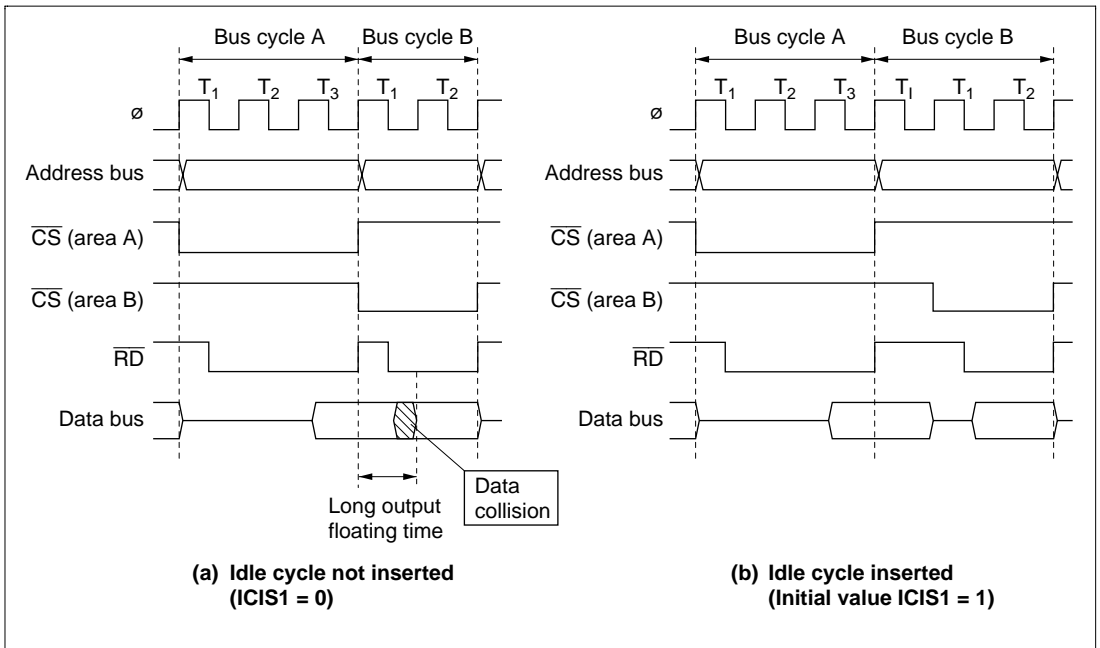

Figure 6-16 Example of Idle Cycle Operation (1)

(2) Write after Read

If an external write occurs after an external read while the ICIS0 bit in BCRH is set to 1, an idle cycle is inserted at the start of the write cycle.

Figure 6-17 shows an example of the operation in this case. In this example, bus cycle A is a read cycle from ROM with a long output floating time, and bus cycle B is a CPU write cycle. In (a), an idle cycle is not inserted, and a collision occurs in cycle B between the read data from ROM and the CPU write data. In (b), an idle cycle is inserted, and a data collision is prevented.

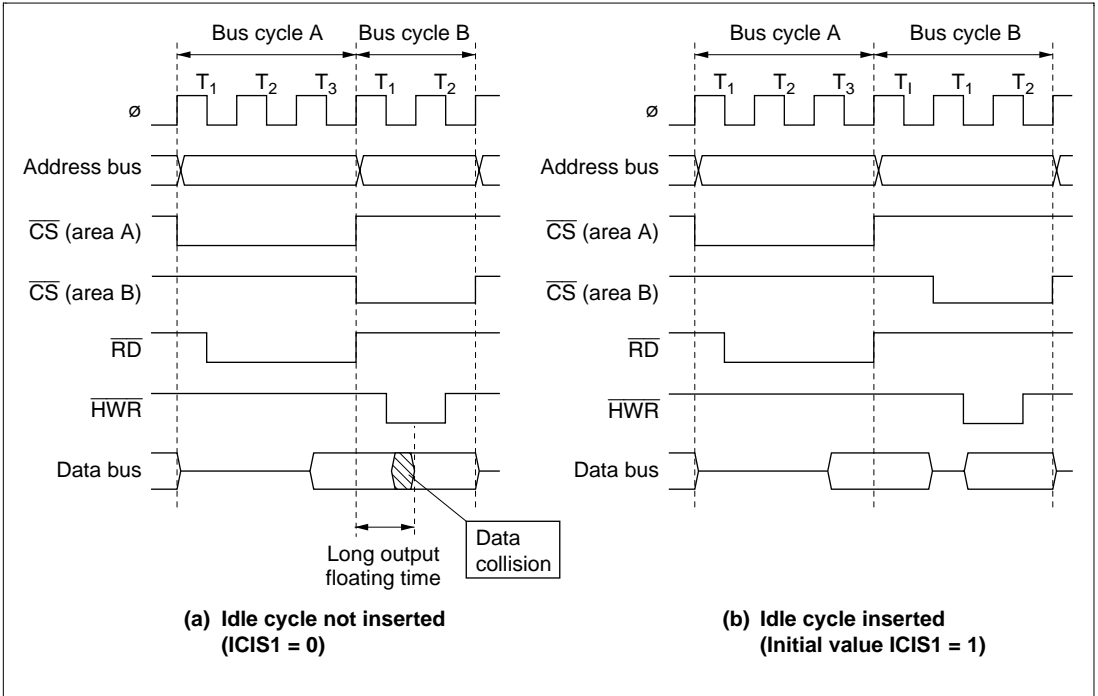

Figure 6-17 Example of Idle Cycle Operation (2)

(3) Relationship between Chip Select (\overline{CS}) Signal and Read (\overline{RD}) Signal

Depending on the system's load conditions, the \overline{RD} signal may lag behind the \overline{CS} signal. An example is shown in figure 6.18.

In this case, with the setting for no idle cycle insertion (a), there may be a period of overlap between the bus cycle A \overline{RD} signal and the bus cycle B \overline{CS} signal.

Setting idle cycle insertion, as in (b), however, will prevent any overlap between the \overline{RD} and \overline{CS} signals.

In the initial state after reset release, idle cycle insertion (b) is set.

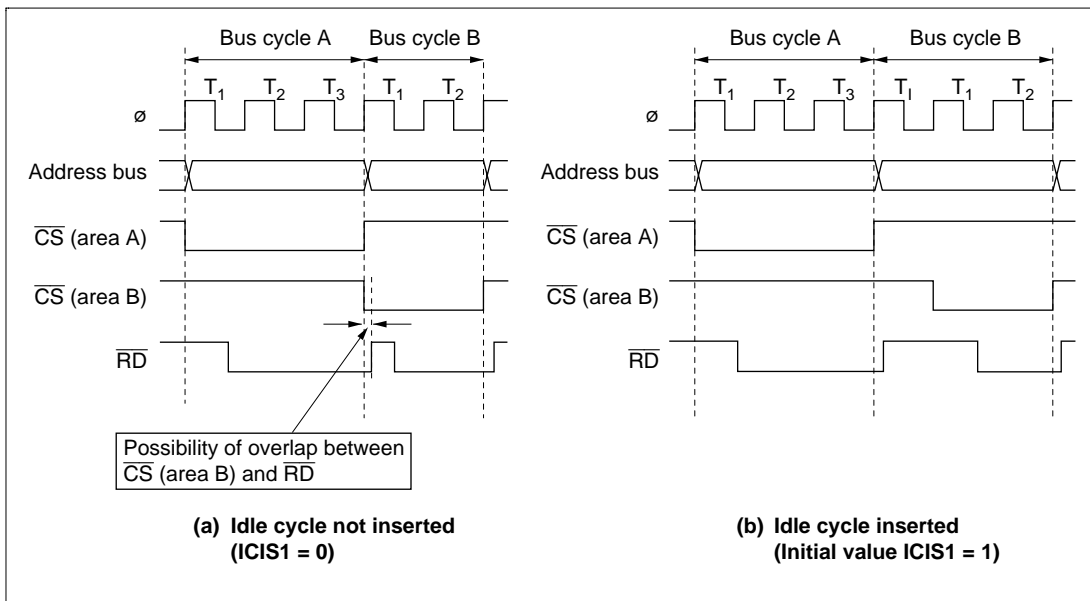

Figure 6.18 Relationship between Chip Select (\overline{CS}) and Read (\overline{RD})

6.6.2 Pin States in Idle Cycle

Table 6-5 shows pin states in an idle cycle.

Table 6-5 Pin States in Idle Cycle

Pins	Pin State
A_{23} to A_0	Contents of next bus cycle
D_{15} to D_0	High impedance
\overline{CSn}	High
\overline{AS}	High
\overline{RD}	High
\overline{HWR}	High
\overline{LWR}	High

6.7 Bus Release

6.7.1 Overview

The H8S/2355 Series can release the external bus in response to a bus request from an external device. In the external bus released state, the internal bus master continues to operate as long as there is no external access.

6.7.2 Operation

In external expansion mode, the bus can be released to an external device by setting the BRLE bit in BCRL to 1. Driving the $\overline{\text{BREQ}}$ pin low issues an external bus request to the H8S/2355 Series. When the $\overline{\text{BREQ}}$ pin is sampled, at the prescribed timing the $\overline{\text{BACK}}$ pin is driven low, and the address bus, data bus, and bus control signals are placed in the high-impedance state, establishing the external bus-released state.

In the external bus released state, an internal bus master can perform accesses using the internal bus. When an internal bus master wants to make an external access, it temporarily defers activation of the bus cycle, and waits for the bus request from the external bus master to be dropped.

When the $\overline{\text{BREQ}}$ pin is driven high, the $\overline{\text{BACK}}$ pin is driven high at the prescribed timing and the external bus released state is terminated.

In the event of simultaneous external bus release request and external access request generation, the order of priority is as follows:

(High) External bus release > Internal bus master external access (Low)

6.7.3 Pin States in External Bus Released State

Table 6-6 shows pin states in the external bus released state.

Table 6-6 Pin States in Bus Released State

Pins	Pin State
A_{23} to A_0	High impedance
D_{15} to D_0	High impedance
\overline{CSn}	High impedance
\overline{AS}	High impedance
\overline{RD}	High impedance
\overline{HWR}	High impedance
\overline{LWR}	High impedance

6.7.4 Transition Timing

Figure 6-19 shows the timing for transition to the bus-released state.

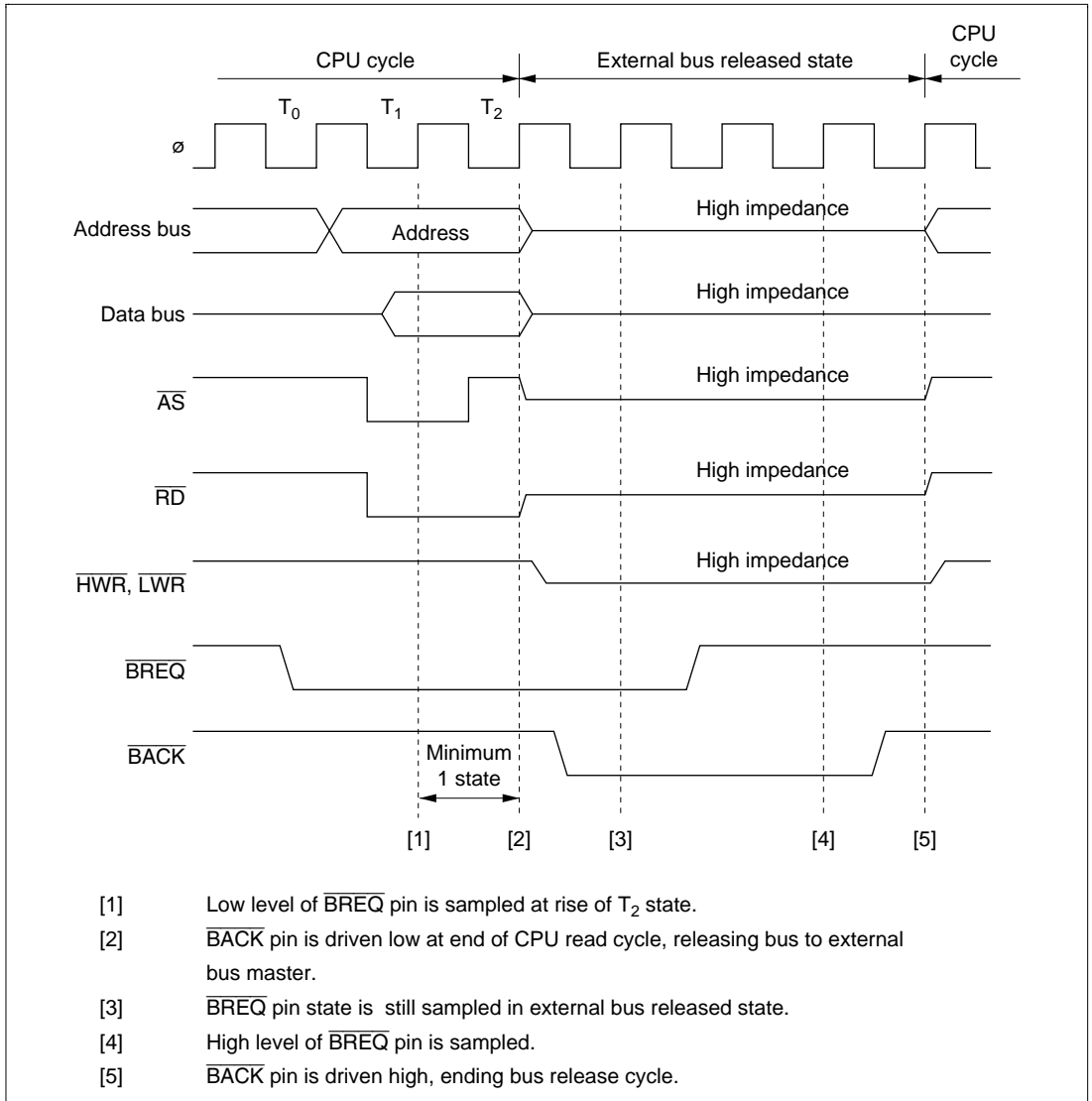

Figure 6-19 Bus-Released State Transition Timing

6.7.5 Usage Note

When MSTPCR is set to H'FFFF or H'EFFF and a transition is made to sleep mode, the external bus release function halts. Therefore, MSTPCR should not be set to H'FFFF or H'EFFF if the external bus release function is to be used in sleep mode.

6.8 Bus Arbitration

6.8.1 Overview

The H8S/2355 Series has a bus arbiter that arbitrates bus master operations.

There are two bus masters, the CPU and DTC, which perform read/write operations when they have possession of the bus. Each bus master requests the bus by means of a bus request signal. The bus arbiter determines priorities at the prescribed timing, and permits use of the bus by means of a bus request acknowledge signal. The selected bus master then takes possession of the bus and begins its operation.

6.8.2 Operation

The bus arbiter detects the bus masters' bus request signals, and if the bus is requested, sends a bus request acknowledge signal to the bus master making the request. If there are bus requests from more than one bus master, the bus request acknowledge signal is sent to the one with the highest priority. When a bus master receives the bus request acknowledge signal, it takes possession of the bus until that signal is canceled.

The order of priority of the bus masters is as follows:

(High) DTC > CPU (Low)

An internal bus access by an internal bus master, and external bus release, can be executed in parallel.

In the event of simultaneous external bus release request, and internal bus master external access request generation, the order of priority is as follows:

(High) External bus release > Internal bus master external access (Low)

6.8.3 Bus Transfer Timing

Even if a bus request is received from a bus master with a higher priority than that of the bus master that has acquired the bus and is currently operating, the bus is not necessarily transferred immediately. There are specific times at which each bus master can relinquish the bus.

CPU: The CPU is the lowest-priority bus master, and if a bus request is received from the DTC, the bus arbiter transfers the bus to the bus master that issued the request. The timing for transfer of the bus is as follows:

- The bus is transferred at a break between bus cycles. However, if a bus cycle is executed in discrete operations, as in the case of a longword-size access, the bus is not transferred between the operations. See Appendix A-5, Bus States During Instruction Execution, for timings at which the bus is not transferred.
- If the CPU is in sleep mode, it transfers the bus immediately.

DTC: The DTC sends the bus arbiter a request for the bus when an activation request is generated.

The DTC can release the bus after a vector read, a register information read (3 states), a single data transfer, or a register information write (3 states). It does not release the bus during a register information read (3 states), a single data transfer, or a register information write (3 states).

6.8.4 External Bus Release Usage Note

External bus release can be performed on completion of an external bus cycle. The \overline{RD} signal and $\overline{CS0}$ to $\overline{CS7}$ signals remain low until the end of the external bus cycle. Therefore, when external bus release is performed, the \overline{RD} and $\overline{CS0}$ to $\overline{CS7}$ signals may change from the low level to the high-impedance state.

6.9 Resets and the Bus Controller

In a power-on reset, the H8S/2355, including the bus controller, enters the reset state at that point, and an executing bus cycle is discontinued.

In a manual reset, the bus controller's registers and internal state are maintained, and an executing external bus cycle is completed. In this case, \overline{WAIT} input is ignored and write data is not guaranteed.

Section 7 Data Transfer Controller

7.1 Overview

The H8S/2355 Series includes a data transfer controller (DTC). The DTC can be activated by an interrupt or software, to transfer data.

7.1.1 Features

The features of the DTC are:

- Transfer possible over any number of channels
 - Transfer information is stored in memory
 - One activation source can trigger a number of data transfers (chain transfer)
- Wide range of transfer modes
 - Normal, repeat, and block transfer modes available
 - Incrementing, decrementing, and fixing of source and destination addresses can be selected
- Direct specification of 16-Mbyte address space possible
 - 24-bit transfer source and destination addresses can be specified
- Transfer can be set in byte or word units
- A CPU interrupt can be requested for the interrupt that activated the DTC
 - An interrupt request can be issued to the CPU after one data transfer ends
 - An interrupt request can be issued to the CPU after the specified data transfers have completely ended
- Activation by software is possible
- Module stop mode can be set
 - The initial setting enables DTC registers to be accessed. DTC operation is halted by setting module stop mode.

7.1.2 Block Diagram

Figure 7-1 shows a block diagram of the DTC.

The DTC's register information is stored in the on-chip RAM*. A 32-bit bus connects the DTC to the on-chip RAM (1 kbyte), enabling 32-bit/1-state reading and writing of the DTC register information and hence helping to increase processing speed.

Note: * When the DTC is used, the RAME bit in SYSCR must be set to 1.

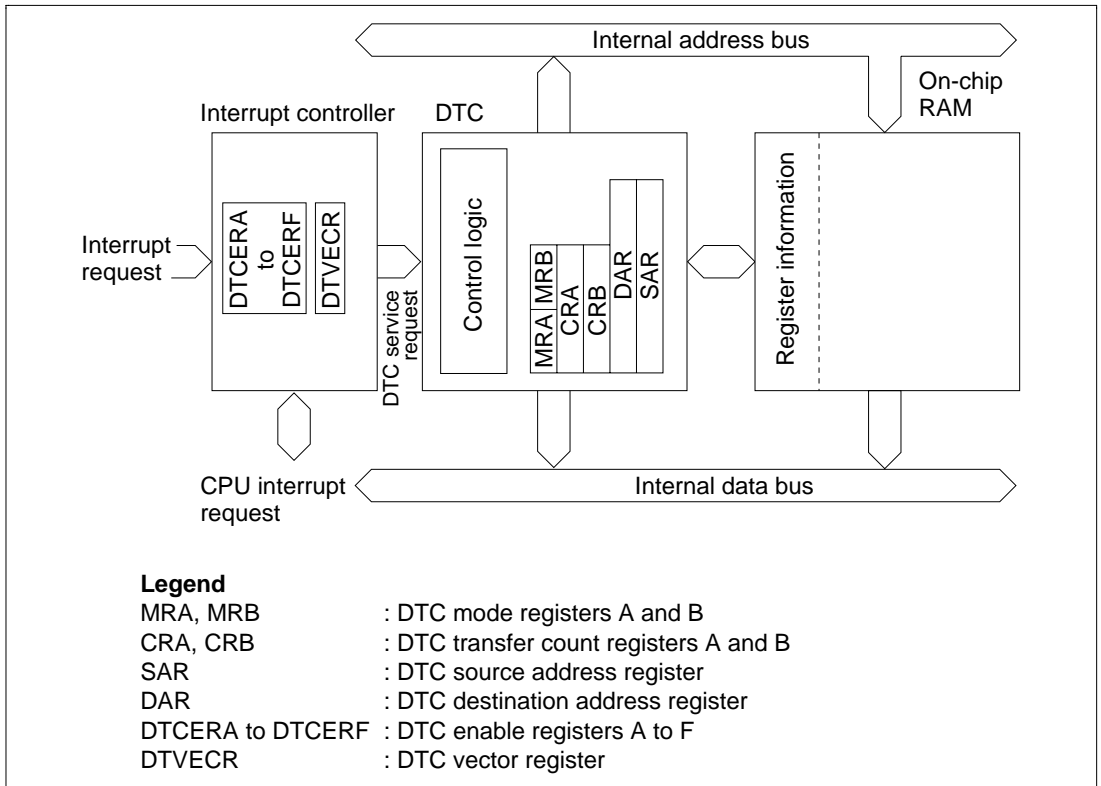

Figure 7-1 Block Diagram of DTC

7.1.3 Register Configuration

Table 7-1 summarizes the DTC registers.

Table 7-1 DTC Registers

Name	Abbreviation	R/W	Initial Value	Address* ¹
DTC mode register A	MRA	—* ²	Undefined	—* ³
DTC mode register B	MRB	—* ²	Undefined	—* ³
DTC source address register	SAR	—* ²	Undefined	—* ³
DTC destination address register	DAR	—* ²	Undefined	—* ³
DTC transfer count register A	CRA	—* ²	Undefined	—* ³
DTC transfer count register B	CRB	—* ²	Undefined	—* ³
DTC enable registers	DTCER	R/W	H'00	H'FF30 to H'FF35
DTC vector register	DTVECR	R/W	H'00	H'FF37
Module stop control register	MSTPCR	R/W	H'3FFF	H'FF3C

Notes: 1. Lower 16 bits of the address.

2. Registers within the DTC cannot be read or written to directly.

3. Register information is located in on-chip RAM addresses H'F800 to H'FBFF. It cannot be located in external space. When the DTC is used, do not clear the RAME bit in SYSCR to 0.

7.2 Register Descriptions

7.2.1 DTC Mode Register A (MRA)

MRA is an 8-bit register that controls the DTC operating mode.

Bit	:	7	6	5	4	3	2	1	0
		SM1	SM0	DM1	DM0	MD1	MD0	DTS	Sz
Initial value	:	Unde- fined	Unde- fined	Unde- fined	Unde- fined	Unde- fined	Unde- fined	Unde- fined	Unde- fined
R/W	:	—	—	—	—	—	—	—	—

Bits 7 and 6—Source Address Mode 1 and 0 (SM1, SM0): These bits specify whether SAR is to be incremented, decremented, or left fixed after a data transfer.

Bit 7	Bit 6	Description
SM1	SM0	
0	—	SAR is fixed
1	0	SAR is incremented after a transfer (by +1 when Sz = 0; by +2 when Sz = 1)
	1	SAR is decremented after a transfer (by -1 when Sz = 0; by -2 when Sz = 1)

Bits 5 and 4—Destination Address Mode 1 and 0 (DM1, DM0): These bits specify whether DAR is to be incremented, decremented, or left fixed after a data transfer.

Bit 5	Bit 4	Description
DM1	DM0	
0	—	DAR is fixed
1	0	DAR is incremented after a transfer (by +1 when Sz = 0; by +2 when Sz = 1)
	1	DAR is decremented after a transfer (by -1 when Sz = 0; by -2 when Sz = 1)

Bits 3 and 2—DTC Mode (MD1, MD0): These bits specify the DTC transfer mode.

Bit 3	Bit 2	
MD1	MD0	Description
0	0	Normal mode
	1	Repeat mode
1	0	Block transfer mode
	1	—

Bit 1—DTC Transfer Mode Select (DTS): Specifies whether the source side or the destination side is set to be a repeat area or block area, in repeat mode or block transfer mode.

Bit 1	
DTS	Description
0	Destination side is repeat area or block area
1	Source side is repeat area or block area

Bit 0—DTC Data Transfer Size (Sz): Specifies the size of data to be transferred.

Bit 0	
Sz	Description
0	Byte-size transfer
1	Word-size transfer

7.2.2 DTC Mode Register B (MRB)

Bit	:	7	6	5	4	3	2	1	0
		CHNE	DISEL	—	—	—	—	—	—
Initial value:		Unde- fined	Unde- fined	Unde- fined	Unde- fined	Unde- fined	Unde- fined	Unde- fined	Unde- fined
R/W	:	—	—	—	—	—	—	—	—

MRB is an 8-bit register that controls the DTC operating mode.

Bit 7—DTC Chain Transfer Enable (CHNE): Specifies chain transfer. With chain transfer, a number of data transfers can be performed consecutively in response to a single transfer request.

In data transfer with CHNE set to 1, determination of the end of the specified number of transfers, clearing of the interrupt source flag, and clearing of DTCER is not performed.

Bit 7

CHNE	Description
------	-------------

0	End of DTC data transfer (activation waiting state is entered)
---	--

1	DTC chain transfer (new register information is read, then data is transferred)
---	---

Bit 6—DTC Interrupt Select (DISEL): Specifies whether interrupt requests to the CPU are disabled or enabled after a data transfer.

Bit 6

DISEL	Description
-------	-------------

0	After a data transfer ends, the CPU interrupt is disabled unless the transfer counter is 0 (the DTC clears the interrupt source flag of the activating interrupt to 0)
---	--

1	After a data transfer ends, the CPU interrupt is enabled (the DTC does not clear the interrupt source flag of the activating interrupt to 0)
---	--

Bits 5 to 0—Reserved: These bits have no effect on DTC operation in the H8S/2355 Series, and should always be written with 0.

7.2.3 DTC Source Address Register (SAR)

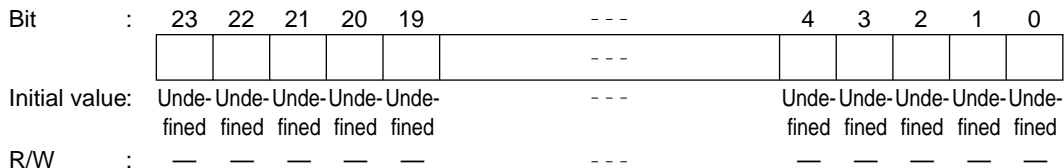

SAR is a 24-bit register that designates the source address of data to be transferred by the DTC. For word-size transfer, specify an even source address.

7.2.4 DTC Destination Address Register (DAR)

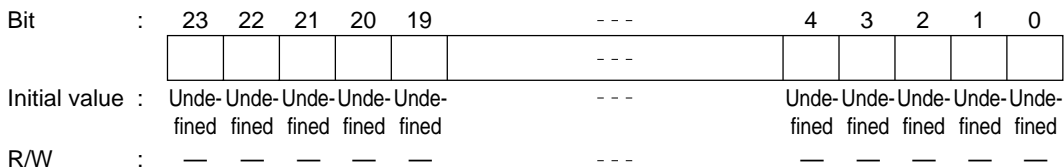

DAR is a 24-bit register that designates the destination address of data to be transferred by the DTC. For word-size transfer, specify an even destination address.

7.2.5 DTC Transfer Count Register A (CRA)

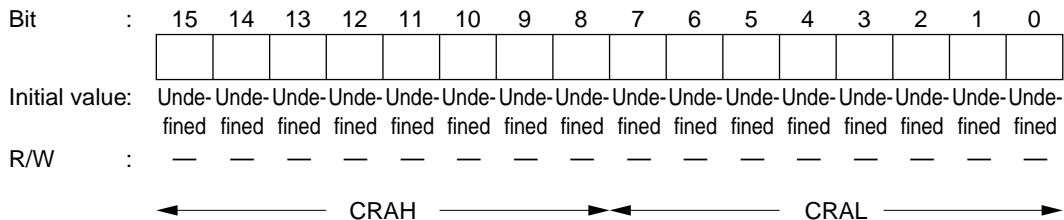

CRA is a 16-bit register that designates the number of times data is to be transferred by the DTC.

In normal mode, the entire CRA functions as a 16-bit transfer counter (1 to 65536). It is decremented by 1 every time data is transferred, and transfer ends when the count reaches H'0000.

In repeat mode or block transfer mode, the CRA is divided into two parts: the upper 8 bits (CRAH) and the lower 8 bits (CRAL). CRAH holds the number of transfers while CRAL functions as an 8-bit transfer counter (1 to 256). CRAL is decremented by 1 every time data is transferred, and the contents of CRAH are sent when the count reaches H'00. This operation is repeated.

7.2.6 DTC Transfer Count Register B (CRB)

Bit	:	15	14	13	12	11	10	9	8	7	6	5	4	3	2	1	0
Initial value:		Unde-	Unde-	Unde-	Unde-	Unde-	Unde-	Unde-	Unde-	Unde-	Unde-	Unde-	Unde-	Unde-	Unde-	Unde-	Unde-
		defined	defined	defined	defined	defined	defined	defined	defined	defined	defined	defined	defined	defined	defined	defined	defined
R/W	:	—	—	—	—	—	—	—	—	—	—	—	—	—	—	—	—

CRB is a 16-bit register that designates the number of times data is to be transferred by the DTC in block transfer mode. It functions as a 16-bit transfer counter (1 to 65536) that is decremented by 1 every time data is transferred, and transfer ends when the count reaches H'0000.

7.2.7 DTC Enable Registers (DTCER)

Bit	:	7	6	5	4	3	2	1	0
		DTCE7	DTCE6	DTCE5	DTCE4	DTCE3	DTCE2	DTCE1	DTCE0
Initial value:		0	0	0	0	0	0	0	0
R/W	:	R/W	R/W	R/W	R/W	R/W	R/W	R/W	R/W

The DTC enable registers comprise six 8-bit readable/writable registers, DTCERA to DTCERF, with bits corresponding to the interrupt sources that can activate the DTC. These bits enable or disable DTC service for the corresponding interrupt sources.

The DTC enable registers are initialized to H'00 by a reset and in hardware standby mode.

Bit n—DTC Activation Enable (DTCEn)

Bit n

DTCEn	Description
0	DTC activation by this interrupt is disabled (Initial value) [Clearing conditions] <ul style="list-style-type: none"> • When the DISEL bit is 1 and the data transfer has ended • When the specified number of transfers have ended
1	DTC activation by this interrupt is enabled [Holding condition] <p style="margin-top: 5px;">When the DISEL bit is 0 and the specified number of transfers have not ended</p>

(n = 7 to 0)

A DTCE bit can be set for each interrupt source that can activate the DTC. The correspondence between interrupt sources and DTCE bits is shown in table 7-4, together with the vector number generated for each interrupt controller.

For DTCE bit setting, use bit manipulation instructions such as BSET and BCLR. If all interrupts are masked, multiple activation sources can be set at one time by writing data after executing a dummy read on the relevant register.

7.2.8 DTC Vector Register (DTVECR)

Bit	:	7	6	5	4	3	2	1	0
		SWDTE	DTVEC6	DTVEC5	DTVEC4	DTVEC3	DTVEC2	DTVEC1	DTVEC0
Initial value:		0	0	0	0	0	0	0	0
R/W	:	R/(W)*	R/W	R/W	R/W	R/W	R/W	R/W	R/W

Note: * A value of 1 can always be written to the SWDTE bit, but 0 can only be written after 1 is read.

DTVECR is an 8-bit readable/writable register that enables or disables DTC activation by software, and sets a vector number for the software activation interrupt.

DTVECR is initialized to H'00 by a reset and in hardware standby mode.

Bit 7—DTC Software Activation Enable (SWDTE): Enables or disables DTC activation by software.

When clearing the SWDTE bit to 0 by software, write 0 to SWDTE after reading SWDTE set to 1.

Bit 7

SWDTE	Description
0	DTC software activation is disabled (Initial value) [Clearing condition] When the DISEL bit is 0 and the specified number of transfers have not ended
1	DTC software activation is enabled [Holding conditions] <ul style="list-style-type: none"> • When the DISEL bit is 1 and data transfer has ended • When the specified number of transfers have ended • During data transfer due to software activation

Bits 6 to 0—DTC Software Activation Vectors 6 to 0 (DTVEC6 to DTVEC0): These bits specify a vector number for DTC software activation.

The vector address is expressed as H'0400 + ((vector number) << 1). <<1 indicates a one-bit left-shift. For example, when DTVEC6 to DTVEC0 = H'10, the vector address is H'0420.

7.2.9 Module Stop Control Register (MSTPCR)

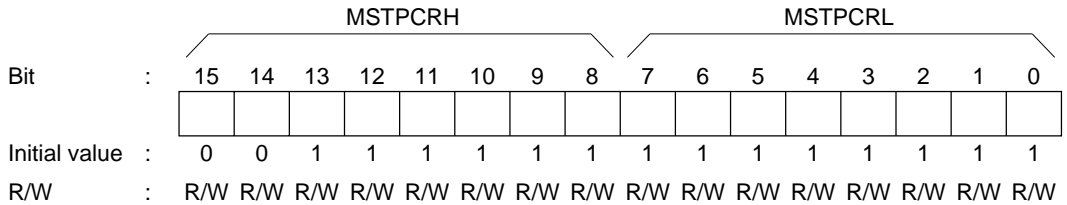

MSTPCR is a 16-bit readable/writable register that performs module stop mode control.

When the MSTP14 bit in MSTPCR is set to 1, the DTC operation stops at the end of the bus cycle and a transition is made to module stop mode. However, 1 cannot be written in the MSTP14 bit while the DTC is operating. For details, see section 19.5, Module Stop Mode.

MSTPCR is initialized to H'3FFF by a reset and in hardware standby mode. It is not initialized in software standby mode.

Bit 14—Module Stop (MSTP14): Specifies the DTC module stop mode.

Bit 14

MSTP14	Description
0	DTC module stop mode cleared (Initial value)
1	DTC module stop mode set

7.3 Operation

7.3.1 Overview

When activated, the DTC reads register information that is already stored in memory and transfers data on the basis of that register information. After the data transfer, it writes updated register information back to memory. Pre-storage of register information in memory makes it possible to transfer data over any required number of channels. Setting the CHNE bit to 1 makes it possible to perform a number of transfers with a single activation.

Figure 7-2 shows a flowchart of DTC operation.

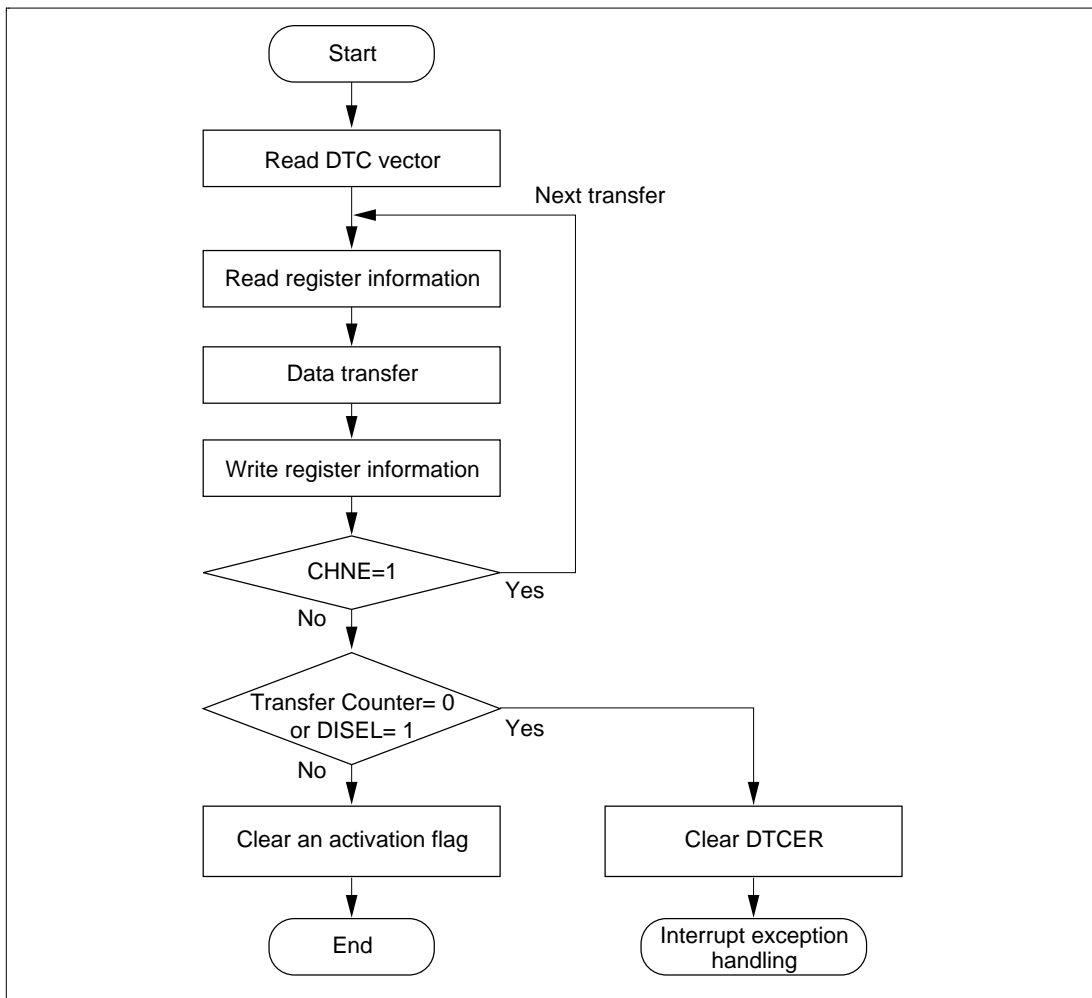

Figure 7-2 Flowchart of DTC Operation

The DTC transfer mode can be normal mode, repeat mode, or block transfer mode.

The 24-bit SAR designates the DTC transfer source address and the 24-bit DAR designates the transfer destination address. After each transfer, SAR and DAR are independently incremented, decremented, or left fixed.

Table 7-2 outlines the functions of the DTC.

Table 7-2 DTC Functions

Transfer Mode	Activation Source	Address Registers	
		Transfer Source	Transfer Destination
<ul style="list-style-type: none"> • Normal mode <ul style="list-style-type: none"> — One transfer request transfers one byte or one word — Memory addresses are incremented or decremented by 1 or 2 — Up to 65,536 transfers possible • Repeat mode <ul style="list-style-type: none"> — One transfer request transfers one byte or one word — Memory addresses are incremented or decremented by 1 or 2 — After the specified number of transfers (1 to 256), the initial state resumes and operation continues • Block transfer mode <ul style="list-style-type: none"> — One transfer request transfers a block of the specified size — Block size is from 1 to 256 bytes or words — Up to 65,536 transfers possible — A block area can be designated at either the source or destination 	<ul style="list-style-type: none"> • IRQ • TPU TGI • 8-bit timer CMI • SCI TXI or RXI • A/D converter ADI • Software 	24 bits	24 bits

7.3.2 Activation Sources

The DTC operates when activated by an interrupt or by a write to DTVECR by software. An interrupt request can be directed to the CPU or DTC, as designated by the corresponding DTCER bit. An interrupt becomes a DTC activation source when the corresponding bit is set to 1, and a CPU interrupt source when the bit is cleared to 0.

At the end of a data transfer (or the last consecutive transfer in the case of chain transfer), the activation source or corresponding DTCER bit is cleared. Table 7-3 shows activation source and DTCER clearance. The activation source flag, in the case of RXI0, for example, is the RDRF flag of SCIO.

Table 7-3 Activation Source and DTCER Clearance

Activation Source	When the DIESEL Bit Is 0 and the Specified Number of Transfers Have Not Ended	When the DIESEL Bit Is 1, or when the Specified Number of Transfers Have Ended
Software activation	The SWDTE bit is cleared to 0	The SWDTE bit remains set to 1 An interrupt is issued to the CPU
Interrupt activation	The corresponding DTCER bit remains set to 1 The activation source flag is cleared to 0	The corresponding DTCER bit is cleared to 0 The activation source flag remains set to 1 A request is issued to the CPU for the activation source interrupt

Figure 7-3 shows a block diagram of activation source control. For details see section 5, Interrupt Controller.

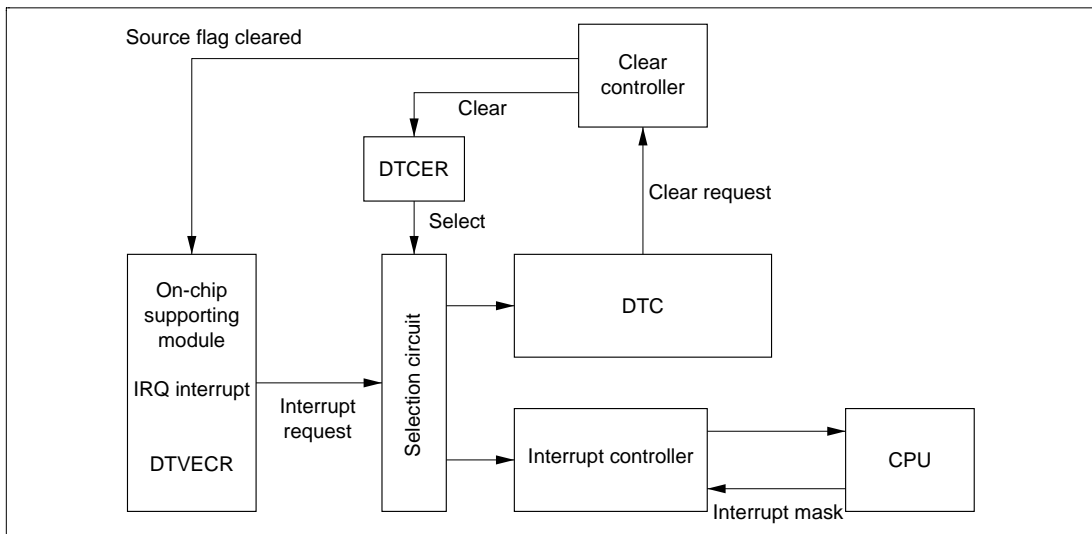

Figure 7-3 Block Diagram of DTC Activation Source Control

When an interrupt has been designated a DTC activation source, existing CPU mask level and interrupt controller priorities have no effect. If there is more than one activation source at the same time, the DTC operates in accordance with the default priorities.

7.3.3 DTC Vector Table

Figure 7-4 shows the correspondence between DTC vector addresses and register information.

Table 7-4 shows the correspondence between activation, vector addresses, and DTCER bits. When the DTC is activated by software, the vector address is obtained from: $H'0400 + (DTVECR[6:0] \ll 1)$ (where $\ll 1$ indicates a 1-bit left shift). For example, if DTVECR is H'10, the vector address is H'0420.

The DTC reads the start address of the register information from the vector address set for each activation source, and then reads the register information from that start address. The register information can be placed at predetermined addresses in the on-chip RAM. The start address of the register information should be an integral multiple of four.

The configuration of the vector address is the same in both normal and advanced modes, a 2-byte unit being used in both cases. These two bytes specify the lower bits of the address in the on-chip RAM.

Interrupt Source	Origin of Interrupt Source	Vector Number	Vector Address	DTCE*	Priority
TGI3A (GR3A compare match/ input capture)	TPU channel 3	48	H'0460	DTCEC5	High ↑
TGI3B (GR3B compare match/ input capture)		49	H'0462	DTCEC4	
TGI3C (GR3C compare match/ input capture)		50	H'0464	DTCEC3	
TGI3D (GR3D compare match/ input capture)		51	H'0466	DTCEC2	
TGI4A (GR4A compare match/ input capture)	TPU channel 4	56	H'0470	DTCEC1	
TGI4B (GR4B compare match/ input capture)		57	H'0472	DTCEC0	
TGI5A (GR5A compare match/ input capture)	TPU channel 5	60	H'0478	DTCED5	
TGI5B (GR5B compare match/ input capture)		61	H'047A	DTCED4	
CMIA0	8-bit timer channel 0	64	H'0480	DTCED3	
CMIB0		65	H'0482	DTCED2	
CMIA1	8-bit timer channel 1	68	H'0488	DTCED1	
CMIB1		69	H'048A	DTCED0	
RXI0 (reception complete 0)	SCI channel 0	81	H'04A2	DTCEE3	
TXI0 (transmit data empty 0)		82	H'04A4	DTCEE2	
RXI1 (reception complete 1)	SCI channel 1	85	H'04AA	DTCEE1	
TXI1 (transmit data empty 1)		86	H'04AC	DTCEE0	
RXI2 (reception complete 2)	SCI channel 2	89	H'04B2	DTCEF7	
TXI2 (transmit data empty 2)		90	H'04B4	DTCEF6	Low

Note: *DTCE bits with no corresponding interrupt are reserved, and should be written with 0.

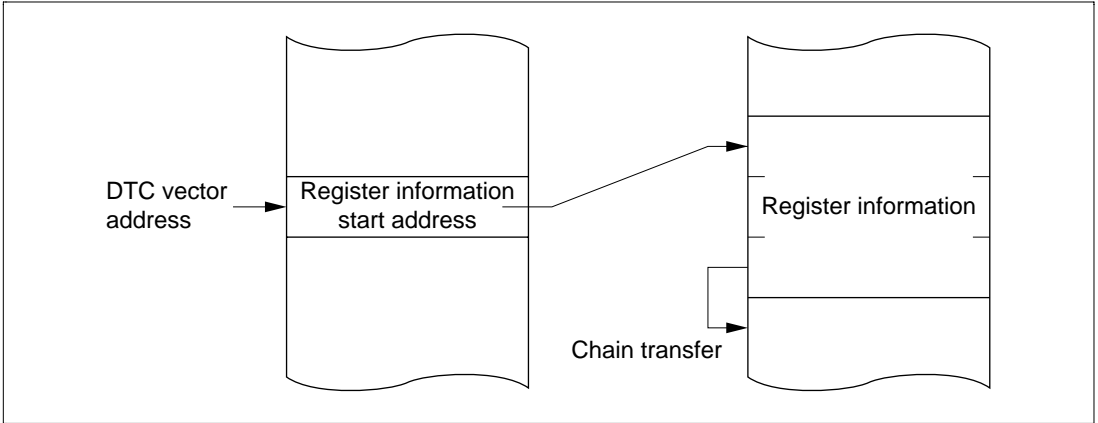

Figure 7-4 Correspondence between DTC Vector Address and Register Information

7.3.4 Location of Register Information in Address Space

Figure 7-5 shows how the register information should be located in the address space.

Locate the MRA, SAR, MRB, DAR, CRA, and CRB registers, in that order, from the start address of the register information (contents of the vector address). In the case of chain transfer, register information should be located in consecutive areas.

Locate the register information in the on-chip RAM (addresses: H'FFF800 to H'FFFBFF).

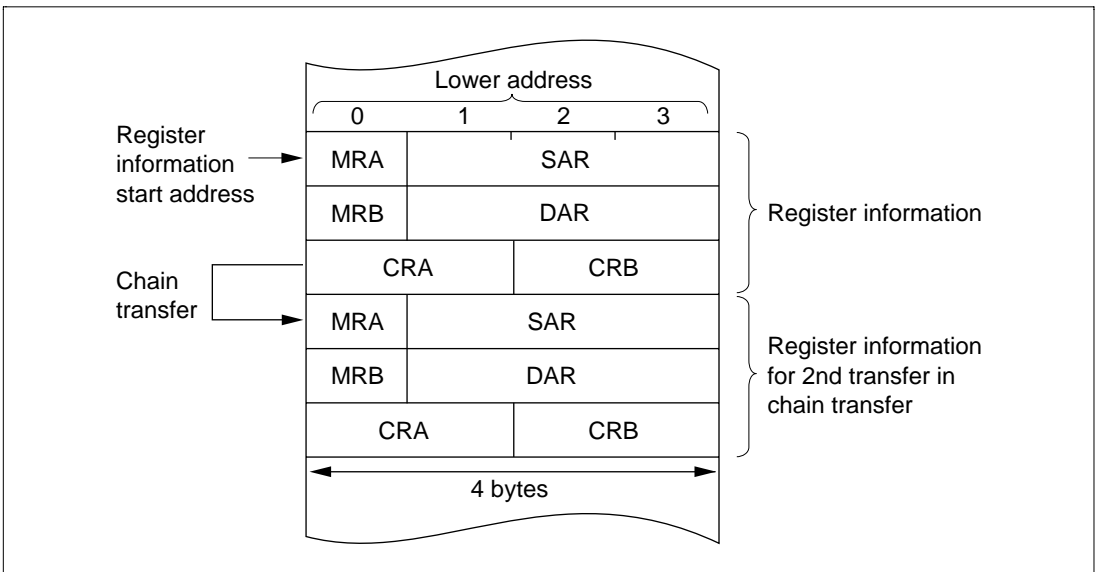

Figure 7-5 Location of Register Information in Address Space

7.3.5 Normal Mode

In normal mode, one operation transfers one byte or one word of data.

From 1 to 65,536 transfers can be specified. Once the specified number of transfers have ended, a CPU interrupt can be requested.

Table 7-5 lists the register information in normal mode and figure 7-6 shows memory mapping in normal mode.

Table 7-5 Register Information in Normal Mode

Name	Abbreviation	Function
DTC source address register	SAR	Designates source address
DTC destination address register	DAR	Designates destination address
DTC transfer count register A	CRA	Designates transfer count
DTC transfer count register B	CRB	Not used

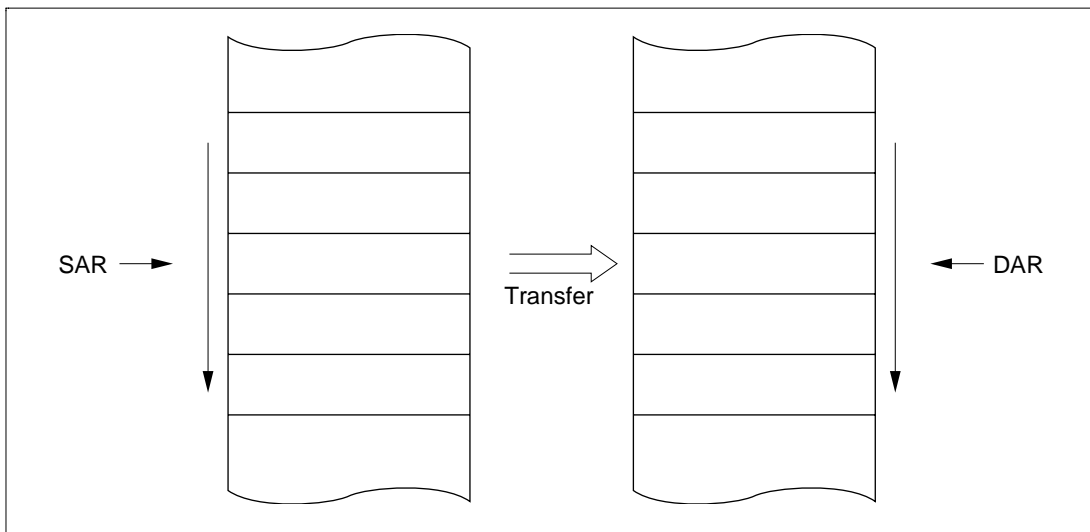

Figure 7-6 Memory Mapping in Normal Mode

7.3.6 Repeat Mode

In repeat mode, one operation transfers one byte or one word of data.

From 1 to 256 transfers can be specified. Once the specified number of transfers have ended, the initial state of the transfer counter and the address register specified as the repeat area is restored, and transfer is repeated. In repeat mode the transfer counter value does not reach H'00, and therefore CPU interrupts cannot be requested when DISEL = 0.

Table 7-6 lists the register information in repeat mode and figure 7-7 shows memory mapping in repeat mode.

Table 7-6 Register Information in Repeat Mode

Name	Abbreviation	Function
DTC source address register	SAR	Designates source address
DTC destination address register	DAR	Designates destination address
DTC transfer count register AH	CRAH	Holds number of transfers
DTC transfer count register AL	CRAL	Designates transfer count (8 bits × 2)
DTC transfer count register B	CRB	Not used

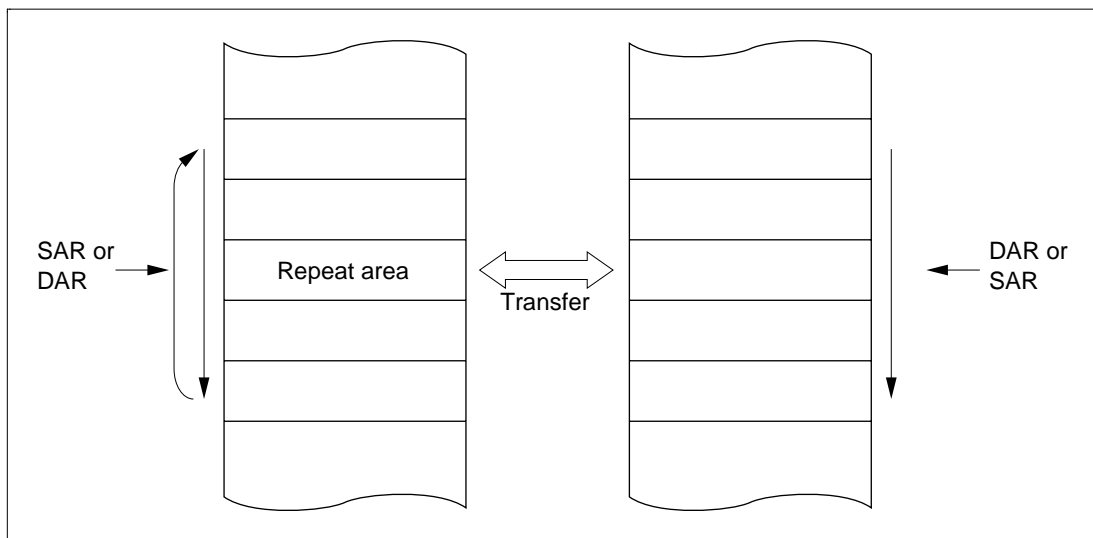

Figure 7-7 Memory Mapping in Repeat Mode

7.3.7 Block Transfer Mode

In block transfer mode, one operation transfers one block of data.

The block size is 1 to 256. When the transfer of one block ends, the initial state of the block size counter and the address register specified as the block area is restored. The other address register is then incremented, decremented, or left fixed.

From 1 to 65,536 transfers can be specified. Once the specified number of transfers have ended, a CPU interrupt is requested.

Table 7-7 lists the register information in block transfer mode and figure 7-8 shows memory mapping in block transfer mode.

Table 7-7 Register Information in Block Transfer Mode

Name	Abbreviation	Function
DTC source address register	SAR	Designates transfer source address
DTC destination address register	DAR	Designates destination address
DTC transfer count register AH	CRAH	Holds block size
DTC transfer count register AL	CRAL	Designates block size count
DTC transfer count register B	CRB	Transfer count

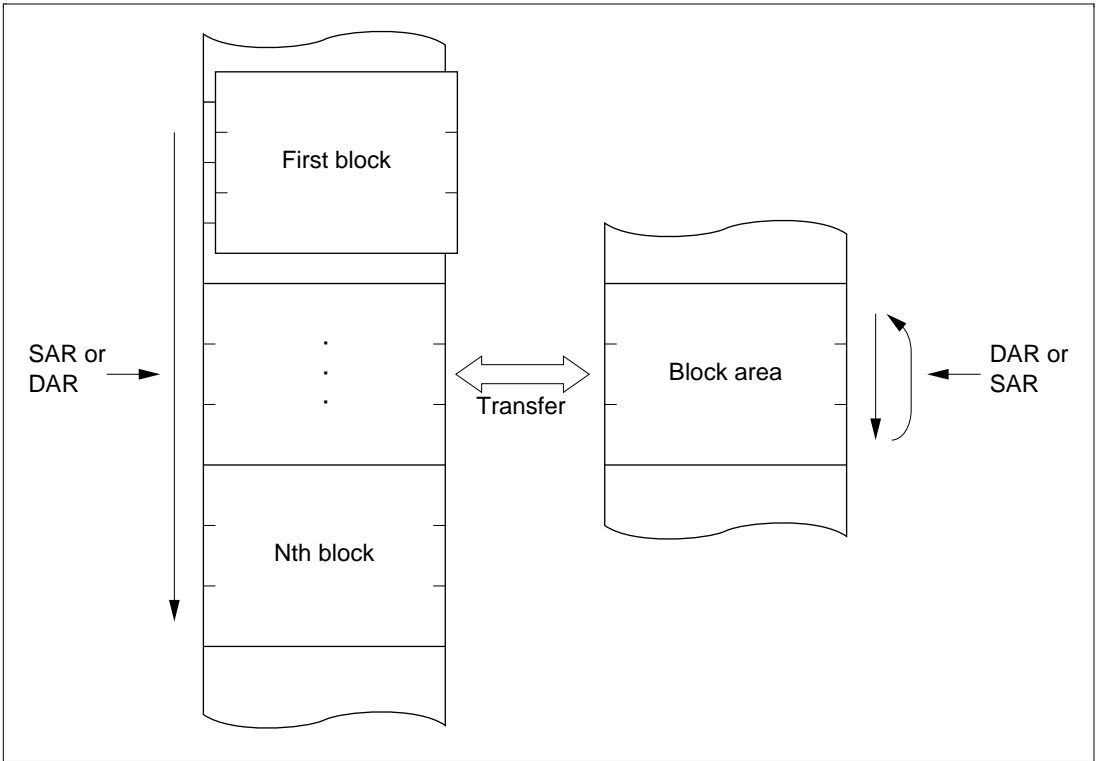

Figure 7-8 Memory Mapping in Block Transfer Mode

7.3.8 Chain Transfer

Setting the CHNE bit to 1 enables a number of data transfers to be performed consecutively in response to a single transfer request. SAR, DAR, CRA, CRB, MRA, and MRB, which define data transfers, can be set independently.

Figure 7-9 shows the memory map for chain transfer.

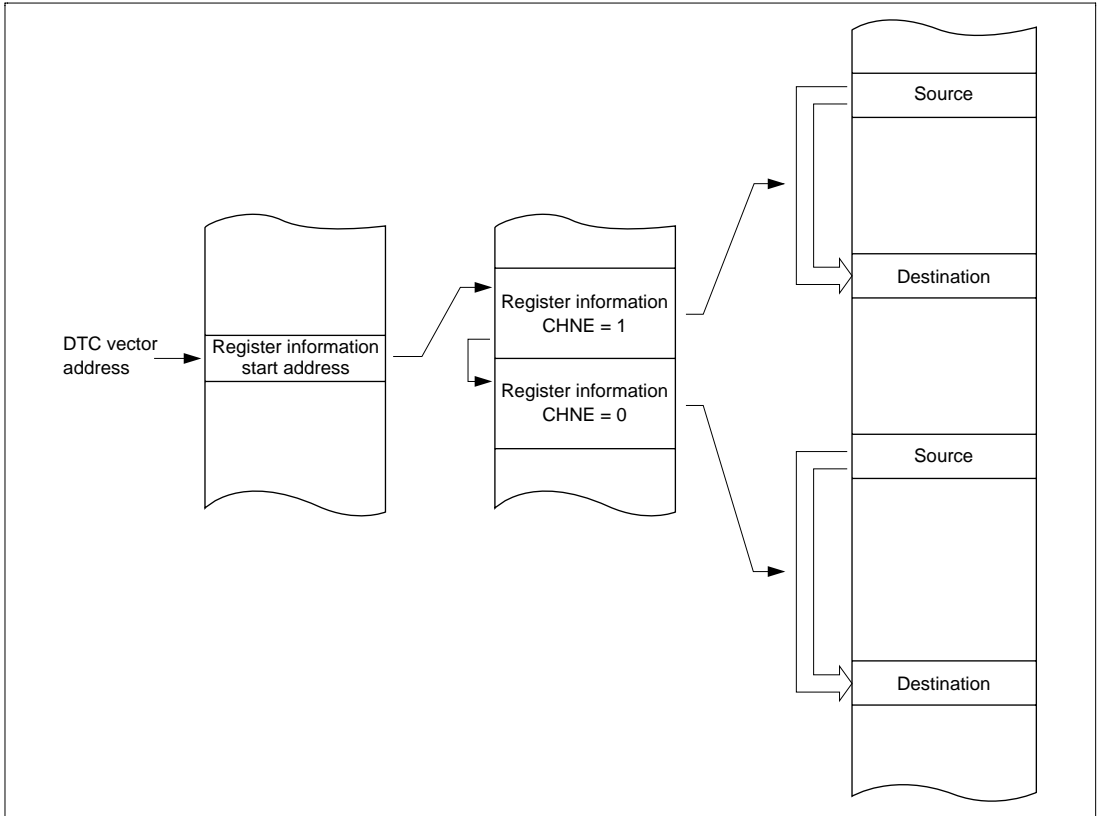

Figure 7-9 Chain Transfer Memory Map

In the case of transfer with CHNE set to 1, an interrupt request to the CPU is not generated at the end of the specified number of transfers or by setting of the DISEL bit to 1, and the interrupt source flag for the activation source is not affected.

7.3.9 Operation Timing

Figures 7-10 to 7-12 show an example of DTC operation timing.

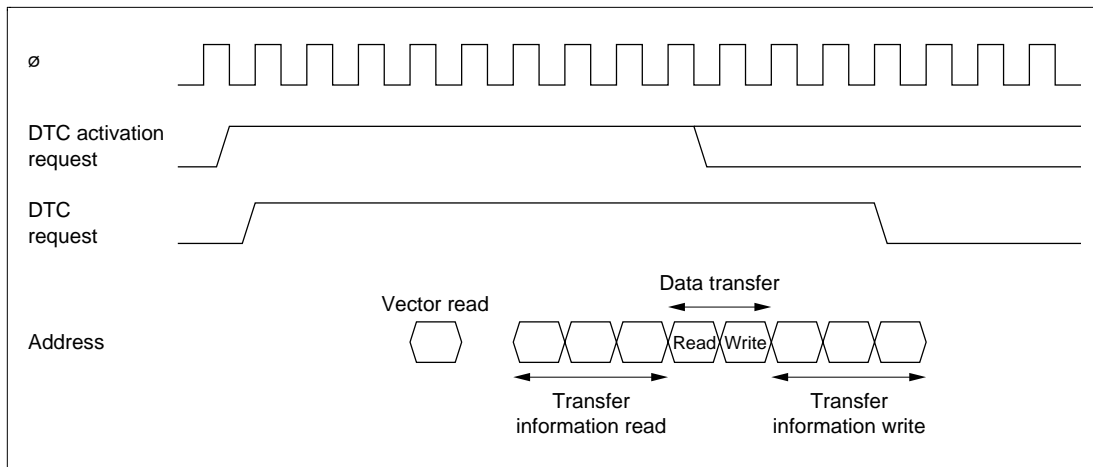

Figure 7-10 DTC Operation Timing (Example in Normal Mode or Repeat Mode)

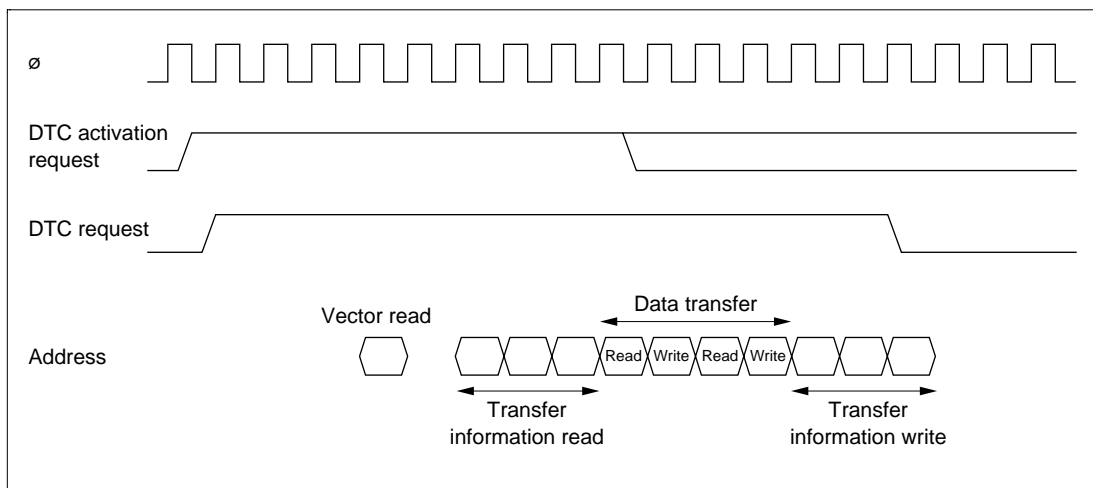

Figure 7-11 DTC Operation Timing (Example of Block Transfer Mode, with Block Size of 2)

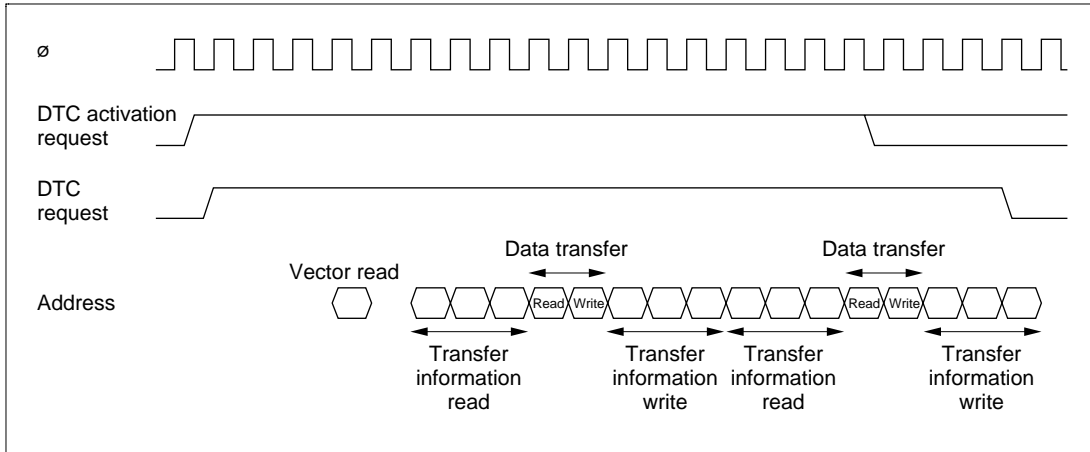

Figure 7-12 DTC Operation Timing (Example of Chain Transfer)

7.3.10 Number of DTC Execution States

Table 7-8 lists execution statuses for a single DTC data transfer, and table 7-9 shows the number of states required for each execution status.

Table 7-8 DTC Execution Statuses

Mode	Register Information				
	Vector Read I	Read/Write J	Data Read K	Data Write L	Internal Operations M
Normal	1	6	1	1	3
Repeat	1	6	1	1	3
Block transfer	1	6	N	N	3

N: Block size (initial setting of CRAH and CRAL)

Table 7-9 Number of States Required for Each Execution Status

Object to be Accessed		On-Chip RAM	On-Chip ROM	On-Chip I/O Registers		External Devices				
Bus width		32	16	8	16	8	16			
Access states		1	1	2	2	2	3	2	3	
Execution status	Vector read	S_I	—	1	—	—	4	6+2m	2	3+m
	Register information read/write	S_J	1	—	—	—	—	—	—	—
	Byte data read	S_K	1	1	2	2	2	3+m	2	3+m
	Word data read	S_K	1	1	4	2	4	6+2m	2	3+m
	Byte data write	S_L	1	1	2	2	2	3+m	2	3+m
	Word data write	S_L	1	1	4	2	4	6+2m	2	3+m
Internal operation		S_M	1							

The number of execution states is calculated from the formula below. Note that Σ means the sum of all transfers activated by one activation event (the number in which the CHNE bit is set to 1, plus 1).

$$\text{Number of execution states} = I \cdot S_I + \Sigma (J \cdot S_J + K \cdot S_K + L \cdot S_L) + M \cdot S_M$$

For example, when the DTC vector address table is located in on-chip ROM, normal mode is set, and data is transferred from the on-chip ROM to an internal I/O register, the time required for the DTC operation is 13 states. The time from activation to the end of the data write is 10 states.

7.3.11 Procedures for Using DTC

Activation by Interrupt: The procedure for using the DTC with interrupt activation is as follows:

- [1] Set the MRA, MRB, SAR, DAR, CRA, and CRB register information in the on-chip RAM.
- [2] Set the start address of the register information in the DTC vector address.
- [3] Set the corresponding bit in DTCER to 1.
- [4] Set the enable bits for the interrupt sources to be used as the activation sources to 1. The DTC is activated when an interrupt used as an activation source is generated.
- [5] After the end of one data transfer, or after the specified number of data transfers have ended, the DTCE bit is cleared to 0 and a CPU interrupt is requested. If the DTC is to continue transferring data, set the DTCE bit to 1.

Activation by Software: The procedure for using the DTC with software activation is as follows:

- [1] Set the MRA, MRB, SAR, DAR, CRA, and CRB register information in the on-chip RAM.
- [2] Set the start address of the register information in the DTC vector address.
- [3] Check that the SWDTE bit is 0.
- [4] Write 1 to SWDTE bit and the vector number to DTVECR.
- [5] Check the vector number written to DTVECR.
- [6] After the end of one data transfer, if the DISEL bit is 0 and a CPU interrupt is not requested, the SWDTE bit is cleared to 0. If the DTC is to continue transferring data, set the SWDTE bit to 1. When the DISEL bit is 1, or after the specified number of data transfers have ended, the SWDTE bit is held at 1 and a CPU interrupt is requested.

7.3.12 Examples of Use of the DTC

(1) Normal Mode

An example is shown in which the DTC is used to receive 128 bytes of data via the SCI.

- [1] Set MRA to fixed source address ($SM1 = SM0 = 0$), incrementing destination address ($DM1 = 1$, $DM0 = 0$), normal mode ($MD1 = MD0 = 0$), and byte size ($Sz = 0$). The DTS bit can have any value. Set MRB for one data transfer by one interrupt ($CHNE = 0$, $DISEL = 0$). Set the SCI RDR address in SAR, the start address of the RAM area where the data will be received in DAR, and 128 (H'0080) in CRA. CRB can be set to any value.
- [2] Set the start address of the register information at the DTC vector address.
- [3] Set the corresponding bit in DTCER to 1.
- [4] Set the SCI to the appropriate receive mode. Set the RIE bit in SCR to 1 to enable the reception complete (RXI) interrupt. Since the generation of a receive error during the SCI reception operation will disable subsequent reception, the CPU should be enabled to accept receive error interrupts.
- [5] Each time reception of one byte of data ends on the SCI, the RDRF flag in SSR is set to 1, an RXI interrupt is generated, and the DTC is activated. The receive data is transferred from RDR to RAM by the DTC. DAR is incremented and CRA is decremented. The RDRF flag is automatically cleared to 0.
- [6] When CRA becomes 0 after the 128 data transfers have ended, the RDRF flag is held at 1, the DTCE bit is cleared to 0, and an RXI interrupt request is sent to the CPU. The interrupt handling routine should perform wrap-up processing.

(2) Software Activation

An example is shown in which the DTC is used to transfer a block of 128 bytes of data by means of software activation. The transfer source address is H'1000 and the destination address is H'2000. The vector number is H'60, so the vector address is H'04C0.

- [1] Set MRA to incrementing source address (SM1 = 1, SM0 = 0), incrementing destination address (DM1 = 1, DM0 = 0), block transfer mode (MD1 = 1, MD0 = 0), and byte size (Sz = 0). The DTS bit can have any value. Set MRB for one block transfer by one interrupt (CHNE = 0). Set the transfer source address (H'1000) in SAR, the destination address (H'2000) in DAR, and 128 (H'8080) in CRA. Set 1 (H'0001) in CRB.
- [2] Set the start address of the register information at the DTC vector address (H'04C0).
- [3] Check that the SWDTE bit in DTVECR is 0. Check that there is currently no transfer activated by software.
- [4] Write 1 to the SWDTE bit and the vector number (H'60) to DTVECR. The write data is H'E0.
- [5] Read DTVECR again and check that it is set to the vector number (H'60). If it is not, this indicates that the write failed. This is presumably because an interrupt occurred between steps 3 and 4 and led to a different software activation. To activate this transfer, go back to step 3.
- [6] If the write was successful, the DTC is activated and a block of 128 bytes of data is transferred.
- [7] After the transfer, an SWDTEND interrupt occurs. The interrupt handling routine should clear the SWDTE bit to 0 and perform other wrap-up processing.

7.4 Interrupts

An interrupt request is issued to the CPU when the DTC finishes the specified number of data transfers, or a data transfer for which the DISEL bit was set to 1. In the case of interrupt activation, the interrupt set as the activation source is generated. These interrupts to the CPU are subject to CPU mask level and interrupt controller priority level control.

In the case of activation by software, a software activated data transfer end interrupt (SWDTEND) is generated.

When the DISEL bit is 1 and one data transfer has ended, or the specified number of transfers have ended, after data transfer ends, the SWDTE bit is held at 1 and an SWDTEND interrupt is generated. The interrupt handling routine should clear the SWDTE bit to 0.

When the DTC is activated by software, an SWDTEND interrupt is not generated during a data transfer wait or during data transfer even if the SWDTE bit is set to 1.

7.5 Usage Notes

Module Stop: When the MSTP14 bit in MSTPCR is set to 1, the DTC clock stops, and the DTC enters the module stop state. However, 1 cannot be written in the MSTP14 bit while the DTC is operating.

On-Chip RAM: The MRA, MRB, SAR, DAR, CRA, and CRB registers are all located in on-chip RAM. When the DTC is used, the RAME bit in SYSCR must not be cleared to 0.

DTCE Bit Setting: For DTCE bit setting, use bit manipulation instructions such as BSET and BCLR. If all interrupts are masked, multiple activation sources can be set at one time by writing data after executing a dummy read on the relevant register.

Section 8 I/O Ports

8.1 Overview

The H8S/2355 Series has 12 I/O ports (ports 1, 2, 3, 5, 6, and A to G), and one input-only port (port 4).

Table 8-1 summarizes the port functions. The pins of each port also have other functions.

Each port includes a data direction register (DDR) that controls input/output (not provided for the input-only port), a data register (DR) that stores output data, and a port register (PORT) used to read the pin states.

Ports A to E have a built-in MOS input pull-up function, and in addition to DR and DDR, have a MOS input pull-up control register (PCR) to control the on/off state of MOS input pull-up.

Ports 3 and A include an open-drain control register (ODR) that controls the on/off state of the output buffer PMOS.

Ports A to E can drive a single TTL load and 90 pF capacitive load, and ports 1, 2, 3, 5, 6, F, and G can drive a single TTL load and 30 pF capacitive load. All the I/O ports can drive a Darlington transistor when in output mode. Ports 1, and A to C can drive an LED (10 mA sink current).

Port 2, and ports 6₄ to 6₇ and A₄ to A₇, are Schmitt-triggered inputs.

For block diagrams of the ports see appendix C, I/O Port Block Diagrams.

Table 8-1 Port Functions

Port	Description	Pins	Mode 1	Mode 2	Mode 3	Mode 4	Mode 5	Mode 6	Mode 7
Port 1	<ul style="list-style-type: none"> 8-bit I/O port 	P1 ₇ /TIOCB2/ TCLKD P1 ₆ /TIOCA2 P1 ₅ /TIOCB1/ TCLKC P1 ₄ /TIOCA1 P1 ₃ /TIOCD0/ TCLKB P1 ₂ /TIOCC0/ TCLKA P1 ₁ /TIOCB0 P1 ₀ /TIOCA0	8-bit I/O port also functioning as TPU I/O pins (TCLKA, TCLKB, TCLKC, TCLKD, TIOCA0, TIOCB0, TIOCC0, TIOCD0, TIOCA1, TIOCB1, TIOCA2, TIOCB2)						
Port 2	<ul style="list-style-type: none"> 8-bit I/O port Schmitt-triggered input 	P2 ₇ /TIOCB5/ TMO1 P2 ₆ /TIOCA5/ TMO0 P2 ₅ /TIOCB4/ TMC11 P2 ₄ /TIOCA4/ TMRI1 P2 ₃ /TIOCD3/ TMCIO P2 ₂ /TIOCC3/ TMRI0 P2 ₁ /TIOCB3 P2 ₀ /TIOCA3	8-bit I/O port also functioning as TPU I/O pins (TIOCA3, TIOCB3, TIOCC3, TIOCD3, TIOCA4, TIOCB4, TIOCA5, TIOCB5), and 8-bit timer (channels 0 and 1) I/O pins (TMRI0, TMCIO, TMO0, TMRI1, TMC11, TMO1)						
Port 3	<ul style="list-style-type: none"> 6-bit I/O port Open-drain output capability 	P3 ₅ /SCK1 P3 ₄ /SCK0 P3 ₃ /RxD1 P3 ₂ /RxD0 P3 ₁ /TxD1 P3 ₀ /TxD0	6-bit I/O port also functioning as SCI (channels 0 and 1) I/O pins (TxD0, RxD0, SCK0, TxD1, RxD1, SCK1)						
Port 4	<ul style="list-style-type: none"> 8-bit input port 	P4 ₇ /AN7/ DA1* ¹ P4 ₆ /AN6/ DA0* ¹ P4 ₅ /AN5 P4 ₄ /AN4 P4 ₃ /AN3 P4 ₂ /AN2 P4 ₁ /AN1 P4 ₀ /AN0	8-bit input port also functioning as A/D converter analog inputs (AN7 to AN0) and D/A converter analog outputs (DA1 and DA0)* ¹						

Port	Description	Pins	Mode 1	Mode 2	Mode 3	Mode 4	Mode 5	Mode 6	Mode 7	
Port 5	<ul style="list-style-type: none"> 4-bit I/O port 	P5 ₃ / $\overline{\text{ADTRG}}$ P5 ₂ / $\overline{\text{SCK2}}$ P5 ₁ / $\overline{\text{RxD2}}$ P5 ₀ / $\overline{\text{TxD2}}$	4-bit I/O port also functioning as SCI (channel 2) I/O pins (TxD2, RxD2, SCK2) and A/D converter input pin ($\overline{\text{ADTRG}}$)							
Port 6	<ul style="list-style-type: none"> 8-bit I/O port Schmitt-triggered input (P6₄ to P6₇) 	P6 ₇ / $\overline{\text{IRQ3}}$ / $\overline{\text{CS7}}$ P6 ₆ / $\overline{\text{IRQ2}}$ / $\overline{\text{CS6}}$ P6 ₅ / $\overline{\text{IRQ1}}$ P6 ₄ / $\overline{\text{IRQ0}}$ P6 ₃ P6 ₂ P6 ₁ / $\overline{\text{CS5}}$ P6 ₀ / $\overline{\text{CS4}}$	8-bit I/O port also functioning as interrupt input pins ($\overline{\text{IRQ0}}$ to $\overline{\text{IRQ3}}$)		8-bit I/O port also functioning as bus control output pins ($\overline{\text{CS4}}$ to $\overline{\text{CS7}}$), and interrupt input pins ($\overline{\text{IRQ0}}$ to $\overline{\text{IRQ3}}$)			8-bit I/O port also functioning as interrupt input pins ($\overline{\text{IRQ0}}$ to $\overline{\text{IRQ3}}$)		
Port A	<ul style="list-style-type: none"> 8-bit I/O port Built-in MOS input pull-up Open-drain output capability Schmitt-triggered input (PA₄ to PA₇) 	PA ₇ / $\overline{\text{A}}_{23}$ / $\overline{\text{IRQ7}}$ PA ₆ / $\overline{\text{A}}_{22}$ / $\overline{\text{IRQ6}}$ PA ₅ / $\overline{\text{A}}_{21}$ / $\overline{\text{IRQ5}}$	Dual function as I/O ports and interrupt input pins ($\overline{\text{IRQ7}}$ to $\overline{\text{IRQ4}}$)		When DDR = 0 (after reset): dual function as input ports and interrupt input pins ($\overline{\text{IRQ7}}$ to $\overline{\text{IRQ5}}$)		When DDR = 0 (after reset): dual function as input ports and interrupt input pins ($\overline{\text{IRQ7}}$ to $\overline{\text{IRQ4}}$)		Dual function as I/O ports and interrupt input pins ($\overline{\text{IRQ7}}$ to $\overline{\text{IRQ4}}$)	
		When DDR = 1: address output			When DDR = 1: address output					
	PA ₄ / $\overline{\text{A}}_{20}$ / $\overline{\text{IRQ4}}$			Address output		When DDR = 1: address output				
		PA ₃ / $\overline{\text{A}}_{19}$ to PA ₀ / $\overline{\text{A}}_{16}$	I/O ports		Address output		When DDR = 0 (after reset): input ports When DDR = 1: address output		I/O ports	

Port	Description	Pins	Mode 1	Mode 2	Mode 3	Mode 4	Mode 5	Mode 6	Mode 7
Port B	<ul style="list-style-type: none"> 8-bit I/O port Built-in MOS input pull-up 	PB ₇ /A ₁₅ to PB ₀ /A ₈	Address output	When DDR = 0 (after reset): input port When DDR = 1: address output	I/O port	Address output		When DDR = 0 (after reset): input port When DDR = 1: address output	I/O port
Port C	<ul style="list-style-type: none"> 8-bit I/O port Built-in MOS input pull-up 	PC ₇ /A ₇ to PC ₀ /A ₀	Address output	When DDR = 0 (after reset): input port When DDR = 1: address output	I/O port	Address output		When DDR = 0 (after reset): input port When DDR = 1: address output	I/O port
Port D	<ul style="list-style-type: none"> 8-bit I/O port Built-in MOS input pull-up 	PD ₇ /D ₁₅ to PD ₀ /D ₈	Data bus input/output		I/O port	Data bus input/output			I/O port
Port E	<ul style="list-style-type: none"> 8-bit I/O port Built-in MOS input pull-up 	PE ₇ /D ₇ to PE ₀ /D ₀	In 8-bit bus mode: I/O port In 16-bit bus mode: data bus input/output		I/O port	In 8-bit bus mode: I/O port In 16-bit bus mode: data bus input/output			I/O port
Port F	<ul style="list-style-type: none"> 8-bit I/O port 	PF ₇ /∅	When DDR = 0: input port When DDR = 1 (after reset): ∅ output	When DDR = 0 (after reset): input port When DDR = 1: ∅ output		When DDR = 0: input port When DDR = 1 (after reset): ∅ output		When DDR = 0 (after reset): input port When DDR = 1: ∅ output	
		PF ₆ /AS PF ₅ /RD PF ₄ /HWR PF ₃ /LWR	AS, RD, HWR, LWR output		I/O port	AS, RD, HWR, LWR output		I/O port	

Port	Description	Pins	Mode 1	Mode 2	Mode 3	Mode 4	Mode 5	Mode 6	Mode 7
Port F	• 8-bit I/O port	PF ₂ / $\overline{\text{WAIT}}$	When WAITE = 0 (after reset): I/O port When WAITE = 1: $\overline{\text{WAIT}}$ input		I/O port	When WAITE = 0 (after reset): I/O port When WAITE = 1: $\overline{\text{WAIT}}$ input			I/O port
		PF ₁ / $\overline{\text{BACK}}$ PF ₀ / $\overline{\text{BREQ}}$	When BRLE = 0 (after reset): I/O port When BRLE = 1: $\overline{\text{BREQ}}$ input, $\overline{\text{BACK}}$ output			When BRLE = 0 (after reset): I/O port When BRLE = 1: $\overline{\text{BREQ}}$ input, $\overline{\text{BACK}}$ output			
Port G	• 5-bit I/O port	PG ₄ / $\overline{\text{CS0}}$	When DDR= 0* ² : input port When DDR= 1* ³ : $\overline{\text{CS0}}$ output		I/O port	When DDR = 0* ² : input port When DDR = 1* ³ : $\overline{\text{CS0}}$ output			I/O port
		PG ₃ / $\overline{\text{CS1}}$ PG ₂ / $\overline{\text{CS2}}$ PG ₁ / $\overline{\text{CS3}}$	I/O port			When DDR = 0 (after reset): input port When DDR = 1: $\overline{\text{CS1}}$, $\overline{\text{CS2}}$, $\overline{\text{CS3}}$ output			
		PG ₀				I/O port			

- Notes: 1. As the H8S/2393 does not support a D/A converter, it does not have the DA0 and DA1 outputs.
2. After a reset in mode 2 or 6
3. After a reset in mode 1, 4 or 5

8.2 Port 1

8.2.1 Overview

Port 1 is an 8-bit I/O port. Port 1 pins also function as TPU I/O pins (TCLKA, TCLKB, TCLKC, TCLKD, TIOCA0, TIOCB0, TIOCC0, TIOCD0, TIOCA1, TIOCB1, TIOCA2, and TIOCB2). Port 1 pin functions are the same in all operating modes.

Figure 8-1 shows the port 1 pin configuration.

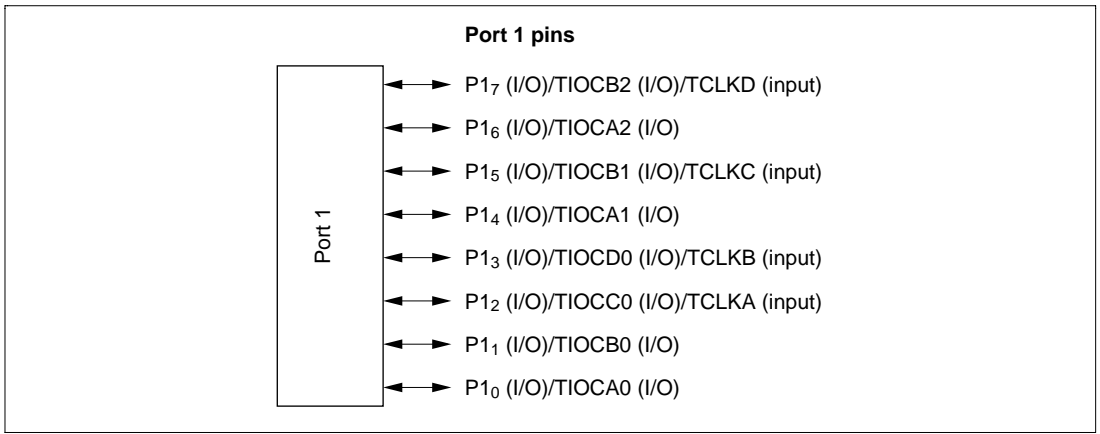

Figure 8-1 Port 1 Pin Functions

8.2.2 Register Configuration

Table 8-2 shows the port 1 register configuration.

Table 8-2 Port 1 Registers

Name	Abbreviation	R/W	Initial Value	Address*
Port 1 data direction register	P1DDR	W	H'00	H'FEB0
Port 1 data register	P1DR	R/W	H'00	H'FF60
Port 1 register	PORT1	R	Undefined	H'FF50

Note: * Lower 16 bits of the address.

Port 1 Data Direction Register (P1DDR)

Bit	:	7	6	5	4	3	2	1	0
		P17DDR	P16DDR	P15DDR	P14DDR	P13DDR	P12DDR	P11DDR	P10DDR
Initial value	:	0	0	0	0	0	0	0	0
R/W	:	W	W	W	W	W	W	W	W

P1DDR is an 8-bit write-only register, the individual bits of which specify input or output for the pins of port 1. P1DDR cannot be read; if it is, an undefined value will be read.

Setting a P1DDR bit to 1 makes the corresponding port 1 pin an output pin, while clearing the bit to 0 makes the pin an input pin.

P1DDR is initialized to H'00 by a power-on reset, and in hardware standby mode. It retains its prior state after a manual reset, and in software standby mode. As the TPU is initialized by a manual reset, the pin states are determined by the P1DDR and P1DR specifications.

Port 1 Data Register (P1DR)

Bit	:	7	6	5	4	3	2	1	0
		P17DR	P16DR	P15DR	P14DR	P13DR	P12DR	P11DR	P10DR
Initial value	:	0	0	0	0	0	0	0	0
R/W	:	R/W	R/W	R/W	R/W	R/W	R/W	R/W	R/W

P1DR is an 8-bit readable/writable register that stores output data for the port 1 pins (P₁₇ to P₁₀).

P1DR is initialized to H'00 by a power-on reset, and in hardware standby mode. It retains its prior state after a manual reset, and in software standby mode.

Port 1 Register (PORT1)

Bit	:	7	6	5	4	3	2	1	0
		P17	P16	P15	P14	P13	P12	P11	P10
Initial value	:	—*	—*	—*	—*	—*	—*	—*	—*
R/W	:	R	R	R	R	R	R	R	R

Note: * Determined by state of pins P₁₇ to P₁₀.

PORT1 is an 8-bit read-only register that shows the pin states. It cannot be written to. Writing of output data for the port 1 pins (P₁₇ to P₁₀) must always be performed on P1DR.

If a port 1 read is performed while P1DDR bits are set to 1, the P1DR values are read. If a port 1 read is performed while P1DDR bits are cleared to 0, the pin states are read.

After a power-on reset and in hardware standby mode, PORT1 contents are determined by the pin states, as P1DDR and P1DR are initialized. PORT1 retains its prior state after a manual reset, and in software standby mode.

8.2.3 Pin Functions

Port 1 pins also function as TPU I/O pins (TCLKA, TCLKB, TCLKC, TCLKD, TIOCA0, TIOCB0, TIOCC0, TIOCD0, TIOCA1, TIOCB1, TIOCA2, and TIOCB2). Port 1 pin functions are shown in table 8-3.

Table 8-3 Port 1 Pin Functions

Pin	Selection Method and Pin Functions		
P1 ₇ /TIOCB2/ TCLKD	The pin function is switched as shown below according to the combination of the TPU channel 2 setting by bits MD3 to MD0 in TMDR2, bits IOB3 to IOB0 in TIOR2, bits CCLR1 and CCLR0 in TCR2, bits TPSC2 to TPSC0 in TCR0 and TCR5, and bit P17DDR.		
	TPU Channel 2 Setting	Table Below (1)	Table Below (2)
	P17DDR	—	0 1
	Pin function	TIOCB2 output	P1 ₇ input P1 ₇ output
			TIOCB2 input * ¹
	TCLKD input * ²		

- Notes: 1. TIOCB2 input when MD3 to MD0 = B'0000, B'01xx, and IOB3 = 1.
 2. TCLKD input when the setting for either TCR0 or TCR5 is: TPSC2 to TPSC0 = B'111.
 TCLKD input when channels 2 and 4 are set to phase counting mode.

TPU Channel 2 Setting	(2)	(1)	(2)	(2)	(1)	(2)
MD3 to MD0	B'0000, B'01xx		B'0010	B'0011		
IOB3 to IOB0	B'0000 B'0100 B'1xxx	B'0001 to B'0011 B'0101 to B'0111	—	B'xx00	Other than B'xx00	
CCLR1, CCLR0	—	—	—	—	Other than B'10	B'10
Output function	—	Output compare output	—	—	PWM mode 2 output	—

x: Don't care

P1₆/TIOCA2

The pin function is switched as shown below according to the combination of the TPU channel 2 setting by bits MD3 to MD0 in TMDR2, bits IOA3 to IOA0 in TIOR2, bits CCLR1 and CCLR0 in TCR2, and bit P16DDR.

TPU Channel 2 Setting	Table Below (1)	Table Below (2)	
P16DDR	—	0	1
Pin function	TIOCA2 output	P1 ₆ input	P1 ₆ output
		TIOCA2 input *1	

Note: 1. TIOCA2 input when MD3 to MD0 = B'0000, B'01xx, and IOA3 = 1.

TPU Channel 2 Setting	(2)	(1)	(2)	(1)	(1)	(2)
MD3 to MD0	B'0000, B'01xx		B'001x	B'0011	B'0011	
IOA3 to IOA0	B'0000 B'0100 B'1xxx	B'0001 to B'0011 B'0101 to B'0111	B'xx00	Other than B'xx00		
CCLR1, CCLR0	—	—	—	—	Other than B'01	B'01
Output function	—	Output compare output	—	PWM mode 1 output *2	PWM mode 2 output	—

x: Don't care

Note: 2. TIOCB2 output is disabled.

P1₅/TIOCB1/
TCLKC

The pin function is switched as shown below according to the combination of the TPU channel 1 setting by bits MD3 to MD0 in TMDR1, bits IOB3 to IOB0 in TIOR1, bits CCLR1 and CCLR0 in TCR1, bits TPSC2 to TPSC0 in TCR0, TCR2, TCR4, and TCR5, and bit P15DDR.

TPU Channel 1 Setting	Table Below (1)		Table Below (2)	
P15DDR	—		0	1
Pin function	TIOCB1 output		P1 ₅ input	P1 ₅ output
			TIOCB1 input * ¹	
	TCLKC input * ²			

- Notes: 1. TIOCB1 input when MD3 to MD0 = B'0000, B'01xx and IOB3 to IOB0 = B'10xx.
 2. TCLKC input when the setting for either TCR0 or TCR2 is: TPSC2 to TPSC0 = B'110; or when the setting for either TCR4 or TCR5 is TPSC2 to TPSC0 = B'101.
 TCLKC input when channels 2 and 4 are set to phase counting mode.

TPU Channel 1 Setting	(2)	(1)	(2)	(2)	(1)	(2)
MD3 to MD0	B'0000, B'01xx		B'0010	B'0011		
IOB3 to IOB0	B'0000 B'0100 B'1xxx	B'0001 to B'0011 B'0101 to B'0111	—	B'xx00	Other than B'xx00	
CCLR1, CCLR0	—	—	—	—	Other than B'10	B'10
Output function	—	Output compare output	—	—	PWM mode 2 output	—

x: Don't care

P1₄/TIOCA1

The pin function is switched as shown below according to the combination of the TPU channel 1 setting by bits MD3 to MD0 in TMDR1, bits IOA3 to IOA0 in TIOR1, bits CCLR1 and CCLR0 in TCR1, and bit P14DDR.

TPU Channel 1 Setting	Table Below (1)	Table Below (2)	
		0	1
P14DDR	—	0	1
Pin function	TIOCA1 output	P1 ₄ input	P1 ₄ output
		TIOCA1 input * ¹	

Note: 1. TIOCA1 input when MD3 to MD0 = B'0000, B'01xx, IOA3 to IOA0 = B'10xx.

TPU Channel 1 Setting	(2)	(1)	(2)	(1)	(1)	(2)
	MD3 to MD0	B'0000, B'01xx		B'001x	B'0010	B'0011
IOA3 to IOA0	B'0000 B'0100 B'1xxx	B'0001 to B'0011 B'0101 to B'0111	B'xx00	Other than B'xx00	Other than B'xx00	
CCLR1, CCLR0	—	—	—	—	Other than B'01	B'01
Output function	—	Output compare output	—	PWM mode 1 output* ²	PWM mode 2 output	—

x: Don't care

Note: 2. TIOCB1 output is disabled.

P1₃/TIOCD0/
TCLKB

The pin function is switched as shown below according to the combination of the TPU channel 0 setting by bits MD3 to MD0 in TMDR0, bits IOD3 to IOD0 in TIOR0L, bits CCLR2 to CCLR0 in TCR0, bits TPSC2 to TPSC0 in TCR0 to TCR2, and bit P13DDR.

TPU Channel 0 Setting	Table Below (1)	Table Below (2)	
P13DDR	—	0	1
Pin function	TIOCD0 output	P1 ₃ input	P1 ₃ output
		TIOCD0 input * ¹	
	TCLKB input * ²		

- Notes: 1. TIOCD0 input when MD3 to MD0 = B'0000, IOD3 to IOD0 = B'10xx.
 2. TCLKB input when the setting for TCR0 to TCR2 is: TPSC2 to TPSC0 = B'101;
 TCLKB input when channels 1 and 5 are set to phase counting mode.

TPU Channel 0 Setting	(2)	(1)	(2)	(2)	(1)	(2)
MD3 to MD0	B'0000		B'0010	B'0011		
IOD3 to IOD0	B'0000 B'0100 B'1xxx	B'0001 to B'0011 B'0101 to B'0111	—	B'xx00	Other than B'xx00	
CCLR2 to CCLR0	—	—	—	—	Other than B'110	B'110
Output function	—	Output compare output	—	—	PWM mode 2 output	—

x: Don't care

P1₂/TIOCC0/
TCLKA

The pin function is switched as shown below according to the combination of the TPU channel 0 setting by bits MD3 to MD0 in TMDR0, bits IOC3 to IOC0 in TIOR0L, bits CCLR2 to CCLR0 in TCR0, bits TPSC2 to TPSC0 in TCR0 to TCR5, and bit P12DDR.

TPU Channel 0 Setting	Table Below (1)	Table Below (2)	
P12DDR	—	0	1
Pin function	TIOCC0 output	P1 ₂ input	P1 ₂ output
		TIOCC0 input * ¹	
	TCLKA input * ²		

- Notes: 1. TIOCC0 input when MD3 to MD0 = B'0000, and IOC3 to IOC0 = B'10xx.
 2. TCLKA input when the setting for TCR0 to TCR5 is: TPSC2 to TPSC0 = B'100;
 TCLKA input when channels 1 and 5 are set to phase counting mode.

TPU Channel 0 Setting	(2)	(1)	(2)	(1)	(1)	(2)
MD3 to MD0	B'0000		B'001x	B'0010	B'0011	
IOC3 to IOC0	B'0000 B'0100 B'1xxx	B'0001 to B'0011 B'0101 to B'0111	B'xx00	Other than B'xx00		
CCLR2 to CCLR0	—	—	—	—	Other than B'101	B'101
Output function	—	Output compare output	—	PWM mode 1 output* ³	PWM mode 2 output	—

x: Don't care

- Note: 3. TIOCC0 output is disabled.
 When BFA = 1 or BFB = 1 in TMDR0, output is disabled and setting (2) applies.

P1₄/TIOCB0

The pin function is switched as shown below according to the combination of the TPU channel 0 setting by bits MD3 to MD0 in TMDR0, bits IOB3 to IOB0 in TIOR0H, bits CCLR2 to CCLR0 in TCR0, and bit P11DDR.

TPU Channel 0 Setting	Table Below (1)	Table Below (2)	
P11DDR	—	0	1
Pin function	TIOCB0 output	P1 ₁ input	P1 ₁ output
		TIOCB0 input *1	

Note: 1. TIOCB0 input when MD3 to MD0 = B'0000, and IOB3 to IOB0 = B'10xx.

TPU Channel 0 Setting	(2)	(1)	(2)	(2)	(1)	(2)
MD3 to MD0	B'0000		B'0010	B'0011		
IOB3 to IOB0	B'0000 B'0100 B'1xxx	B'0001 to B'0011 B'0101 to B'0111	—	B'xx00	Other than B'xx00	
CCLR2 to CCLR0	—	—	—	—	Other than B'010	B'010
Output function	—	Output compare output	—	—	PWM mode 2 output	—

x: Don't care

P1₀/TIOCA0

The pin function is switched as shown below according to the combination of the TPU channel 0 setting by bits MD3 to MD0 in TMDR0, bits IOA3 to IOA0 in TIOR0H, bits CCLR2 to CCLR0 in TCR0, and bit P10DDR.

TPU Channel 0 Setting	Table Below (1)	Table Below (2)	
		0	1
P10DDR	—	0	1
Pin function	TIOCA0 output	P1 ₀ input	P1 ₀ output
		TIOCA0 input * ¹	

Note: 1. TIOCA0 input when MD3 to MD0 = B'0000, and IOA3 to IOA0 = B'10xx.

TPU Channel 0 Setting	(2)	(1)	(2)	(1)	(1)	(2)
	B'0000		B'001x	B'0010	B'0011	
IOA3 to IOA0	B'0000 B'0100 B'1xxx	B'0001 to B'0011 B'0101 to B'0111	B'xx00	Other than B'xx00		
CCLR2 to CCLR0	—	—	—	—	Other than B'001	B'001
Output function	—	Output compare output	—	PWM mode 1 output* ²	PWM mode 2 output	—

x: Don't care

Note: 2. TIOCB0 output is disabled.

8.3 Port 2

8.3.1 Overview

Port 2 is an 8-bit I/O port. Port 2 pins also function as TPU I/O pins (TIOCA3, TIOCB3, TIOCC3, TIOCD3, TIOCA4, TIOCB4, TIOCA5, and TIOCB5), and 8-bit timer I/O pins (TMRI0, TMCIO, TMO0, TMRI1, TMC11, and TMO1). Port 2 pin functions are the same in all operating modes. Port 2 uses Schmitt-triggered input.

Figure 8-2 shows the port 2 pin configuration.

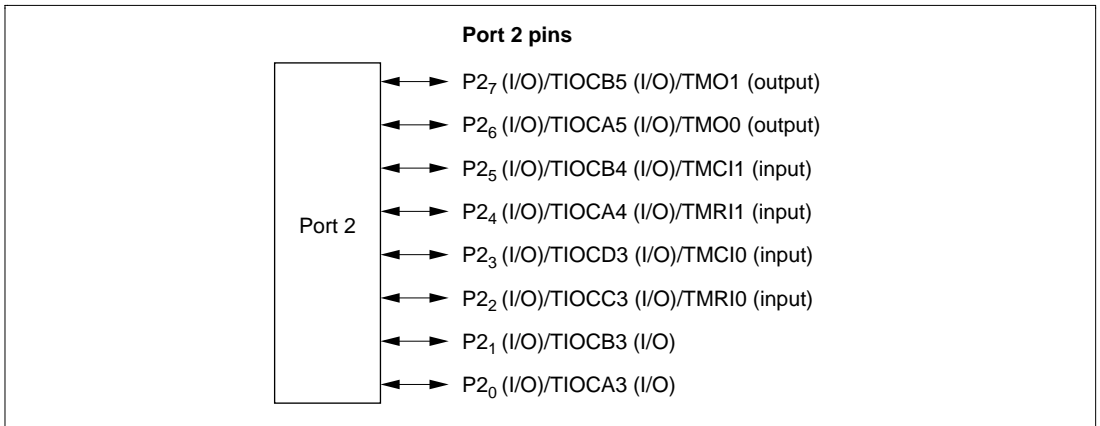

Figure 8-2 Port 2 Pin Functions

8.3.2 Register Configuration

Table 8-4 shows the port 2 register configuration.

Table 8-4 Port 2 Registers

Name	Abbreviation	R/W	Initial Value	Address*
Port 2 data direction register	P2DDR	W	H'00	H'FEB1
Port 2 data register	P2DR	R/W	H'00	H'FF61
Port 2 register	PORT2	R	Undefined	H'FF51

Note: * Lower 16 bits of the address.

Port 2 Data Direction Register (P2DDR)

Bit	:	7	6	5	4	3	2	1	0
		P27DDR	P26DDR	P25DDR	P24DDR	P23DDR	P22DDR	P21DDR	P20DDR
Initial value	:	0	0	0	0	0	0	0	0
R/W	:	W	W	W	W	W	W	W	W

P2DDR is an 8-bit write-only register, the individual bits of which specify input or output for the pins of port 2. P2DDR cannot be read; if it is, an undefined value will be read.

Setting a P2DDR bit to 1 makes the corresponding port 2 pin an output pin, while clearing the bit to 0 makes the pin an input pin.

P2DDR is initialized to H'00 by a power-on reset, and in hardware standby mode. It retains its prior state after a manual reset, and in software standby mode. As the TPU and 8-bit timer are initialized by a manual reset, the pin states are determined by the P2DDR and P2DR specifications.

Port 2 Data Register (P2DR)

Bit	:	7	6	5	4	3	2	1	0
		P27DR	P26DR	P25DR	P24DR	P23DR	P22DR	P21DR	P20DR
Initial value	:	0	0	0	0	0	0	0	0
R/W	:	R/W	R/W	R/W	R/W	R/W	R/W	R/W	R/W

P2DR is an 8-bit readable/writable register that stores output data for the port 2 pins (P2₇ to P2₀).

P2DR is initialized to H'00 by a power-on reset, and in hardware standby mode. It retains its prior state after a manual reset, and in software standby mode.

Port 2 Register (PORT2)

Bit	:	7	6	5	4	3	2	1	0
		P27	P26	P25	P24	P23	P22	P21	P20
Initial value	:	—*	—*	—*	—*	—*	—*	—*	—*
R/W	:	R	R	R	R	R	R	R	R

Note: * Determined by state of pins P2₇ to P2₀.

PORT2 is an 8-bit read-only register that shows the pin states. It cannot be written to. Writing of output data for the port 2 pins (P2₇ to P2₀) must always be performed on P2DR.

If a port 2 read is performed while P2DDR bits are set to 1, the P2DR values are read. If a port 2 read is performed while P2DDR bits are cleared to 0, the pin states are read.

After a power-on reset and in hardware standby mode, PORT2 contents are determined by the pin states, as P2DDR and P2DR are initialized. PORT2 retains its prior state after a manual reset, and in software standby mode.

8.3.3 Pin Functions

Port 2 pins also function as TPU I/O pins (TIOCA3, TIOCB3, TIOCC3, TIOCD3, TIOCA4, TIOCB4, TIOCA5, and TIOCB5), and 8-bit timer I/O pins (TMRI0, TMCI0, TMO0, TMRI1, TMCI1, and TMO1). Port 2 pin functions are shown in table 8-5.

Table 8-5 Port 2 Pin Functions

Pin	Selection Method and Pin Functions			
-----	------------------------------------	--	--	--

P2 ₇ /TIOCB5/ TMO1	The pin function is switched as shown below according to the combination of the TPU channel 5 setting by bits MD3 to MD0 in TMDR5, bits IOB3 to IOB0 in TIOR5, bits CCLR1 and CCLR0 in TCR5, bits OS3 to OS0 in TCSR1, and bit P27DDR.			
----------------------------------	--	--	--	--

OS3 to OS0	All 0		Any 1	
TPU Channel 5 Setting	Table Below (1)	Table Below (2)		—
P27DDR	—	0	1	—
Pin function	TIOCB5 output	P2 ₇ input	P2 ₇ output	TMO1 output
		TIOCB5 input *		

Note: * TIOCB5 input when MD3 to MD0 = B'0000, B'01xx, and IOB3 = 1.

TPU Channel 5 Setting	(2)	(1)	(2)	(2)	(1)	(2)
MD3 to MD0	B'0000, B'01xx		B'0010	B'0011		
IOB3 to IOB0	B'0000 B'0100 B'1xxx	B'0001 to B'0011 B'0101 to B'0111	—	B'xx00	Other than B'xx00	
CCLR1, CCLR0	—	—	—	—	Other than B'10	B'10
Output function	—	Output compare output	—	—	PWM mode 2 output	—

x: Don't care

Pin**Selection Method and Pin Functions**P2₆/TIOCA5/
TMO0

The pin function is switched as shown below according to the combination of the TPU channel 5 setting by bits MD3 to MD0 in TMDR5, bits IOA3 to IOA0 in TIOR5, bits CCLR1 and CCLR0 in TCR5, bits OS3 to OS0 in TCSR0, and bit P26DDR.

OS3 to OS0	All 0			Any 1
TPU Channel 5 Setting	Table Below (1)	Table Below (2)		—
P26DDR	—	0	1	—
NDER6	—	—	0	—
Pin function	TIOCA5 output	P2 ₆ input	P2 ₆ output	TMO0 output
		TIOCA5 input * ¹		

Note: 1. TIOCA5 input when MD3 to MD0 = B'0000, B'01xx, and IOA3 = 1.

TPU Channel 5 Setting	(2)	(1)	(2)	(1)	(1)	(2)
MD3 to MD0	B'0000, B'01xx		B'001x	B'0010	B'0011	
IOA3 to IOA0	B'0000 B'0100 B'1xxx	B'0001 to B'0011 B'0101 to B'0111	B'xx00	Other than B'xx00		
CCLR1, CCLR0	—	—	—	—	Other than B'01	B'01
Output function	—	Output compare output	—	PWM mode 1 output* ²	PWM mode 2 output	—

x: Don't care

Note: 2. TIOCB5 output is disabled.

P2₅/TIOCB4/
TMC11

This pin is used as the 8-bit timer external clock input pin when external clock is selected with bits CKS2 to CKS0 in TCR1.

The pin function is switched as shown below according to the combination of the TPU channel 4 setting by bits MD3 to MD0 in TMDR4 and bits IOB3 to IOB0 in TIOR4, bits CCLR1 and CCLR0 in TCR4, and bit P25DDR.

TPU Channel 4 Setting	Table Below (1)	Table Below (2)	
P25DDR	—	0	1
Pin function	TIOCB4 output	P2 ₅ input	P2 ₅ output
		TIOCB4 input *1	
	TMC11 input		

Note: 1. TIOCB4 input when MD3 to MD0 = B'0000, B'01xx, and IOB3 to IOB0 = B'10xx.

TPU Channel 4 Setting	(2)	(1)	(2)	(2)	(1)	(2)
MD3 to MD0	B'0000, B'01xx		B'0010	B'0011		
IOB3 to IOB0	B'0000 B'0100 B'1xxx	B'0001 to B'0011 B'0101 to B'0111	—	B'xx00	Other than B'xx00	
CCLR1, CCLR0	—	—	—	—	Other than B'10	B'10
Output function	—	Output compare output	—	—	PWM mode 2 output	—

x: Don't care

P2₄/TIOCA4/
TMR11

This pin is used as the 8-bit timer counter reset pin when bits CCLR1 and CCLR0 in TCR1 are both set to 1.

The pin function is switched as shown below according to the combination of the TPU channel 4 setting by bits MD3 to MD0 in TMDR4, bits IOA3 to IOA0 in TIOR4, bits CCLR1 and CCLR0 in TCR4, and bit P24DDR.

TPU Channel 4 Setting	Table Below (1)	Table Below (2)	
P24DDR	—	0	1
Pin function	TIOCA4 output	P2 ₄ input	P2 ₄ output
		TIOCA4 input * ¹	
TMR11 input			

Note: 1. TIOCA4 input when MD3 to MD0 = B'0000, B'01xx, and IOA3 to IOA0 = B'10xx.

TPU Channel 4 Setting	(2)	(1)	(2)	(1)	(1)	(2)
MD3 to MD0	B'0000, B'01xx		B'001x	B'0010	B'0011	
IOA3 to IOA0	B'0000 B'0100 B'1xxx	B'0001 to B'0011 B'0101 to B'0111	B'xx00	Other than B'xx00		
CCLR1, CCLR0	—	—	—	—	Other than B'01	B'01
Output function	—	Output compare output	—	PWM mode 1 output* ²	PWM mode 2 output	—

x: Don't care

Note: 2. TIOCB4 output is disabled.

P2₃/TIOCD3/
TMC10

This pin is used as the 8-bit timer external clock input pin when external clock is selected with bits CKS2 to CKS0 in TCR0.

The pin function is switched as shown below according to the combination of the TPU channel 3 setting by bits MD3 to MD0 in TMDR3, bits IOD3 to IOD0 in TIOR3L, bits CCLR2 to CCLR0 in TCR3, and bit P23DDR.

TPU Channel 3 Setting	Table Below (1)	Table Below (2)	
P23DDR	—	0	1
Pin function	TIOCD3 output	P2 ₃ input	P2 ₃ output
		TIOCD3 input * ¹	
	TMC10 input		

Note: 1. TIOCD3 input when MD3 to MD0 = B'0000, and IOD3 to IOD0 = B'10xx.

TPU Channel 3 Setting	(2)	(1)	(2)	(2)	(1)	(2)
MD3 to MD0	B'0000		B'0010	B'0011		
IOD3 to IOD0	B'0000 B'0100 B'1xxx	B'0001 to B'0011 B'0101 to B'0111	—	B'xx00	Other than B'xx00	
CCLR2 to CCLR0	—	—	—	—	Other than B'110	B'110
Output function	—	Output compare output	—	—	PWM mode 2 output	—

x: Don't care

P₂/TIOCC3/
TMCIO

This pin is used as the 8-bit timer counter reset pin when bits CCLR1 and CCLR0 in TCR0 are both set to 1.

The pin function is switched as shown below according to the combination of the TPU channel 3 setting by bits MD3 to MD0 in TMDR3, bits IOC3 to IOC0 in TIOR3L, bits CCLR2 to CCLR0 in TCR3, and bit P22DDR.

TPU Channel 3 Setting	Table Below (1)	Table Below (2)	
P22DDR	—	0	1
Pin function	TIOCC3 output	P ₂ input	P ₂ output
		TIOCC3 input * ¹	
	TMR10 input		

Note: 1. TIOCC3 input when MD3 to MD0 = B'0000, and IOC3 to IOC0 = B'10xx.

TPU Channel 3 Setting	(2)	(1)	(2)	(1)	(1)	(2)
MD3 to MD0	B'0000		B'001x	B'0010	B'0011	
IOC3 to IOC0	B'0000 B'0100 B'1xxx	B'0001 to B'0011 B'0101 to B'0111	B'xx00	Other than B'xx00		
CCLR2 to CCLR0	—	—	—	—	Other than B'101	B'101
Output function	—	Output compare output	—	PWM mode 1 output* ²	PWM mode 2 output	—

x: Don't care

Note: 2. TIOCD3 output is disabled.
When BFA = 1 or BFB = 1 in TMDR3, output is disabled and setting (2) applies.

P2₄/TIOCB3

The pin function is switched as shown below according to the combination of the TPU channel 3 setting by bits MD3 to MD0 in TMDR3, bits IOB3 to IOB0 in TIOR3H, bits CCLR2 to CCLR0 in TCR3, and bit P21DDR.

TPU Channel 3 Setting	Table Below (1)	Table Below (2)	
P21DDR	—	0	1
Pin function	TIOCB3 output	P2 ₄ input	P2 ₄ output
		TIOCB3 input * ¹	

Note: 1. TIOCB3 input when MD3 to MD0 = B'0000, and IOB3 to IOB0 = B'10xx.

TPU Channel 3 Setting	(2)	(1)	(2)	(2)	(1)	(2)
MD3 to MD0	B'0000		B'0010	B'0011		
IOB3 to IOB0	B'0000 B'0100 B'1xxx	B'0001 to B'0011 B'0101 to B'0111	—	B'xx00	Other than B'xx00	
CCLR2 to CCLR0	—	—	—	—	Other than B'010	B'010
Output function	—	Output compare output	—	—	PWM mode 2 output	—

x: Don't care

P2₀/TIOCA3

The pin function is switched as shown below according to the combination of the TPU channel 3 setting by bits MD3 to MD0 in TMDR3, bits IOA3 to IOA0 in TIOR3H, bits CCLR2 to CCLR0 in TCR3, and bit P20DDR.

TPU Channel 3 Setting	Table Below (1)	Table Below (2)	
P20DDR	—	0	1
Pin function	TIOCA3 output	P2 ₀ input	P2 ₀ output
		TIOCA3 input * ¹	

Note: 1. TIOCA3 input when MD3 to MD0 = B'0000, and IOA3 to IOA0 = B'10xx.

TPU Channel 3 Setting	(2)	(1)	(2)	(1)	(1)	(2)
MD3 to MD0	B'0000		B'001x	B'0010	B'0011	
IOA3 to IOA0	B'0000 B'0100 B'1xxx	B'0001 to B'0011 B'0101 to B'0111	B'xx00	Other than B'xx00		
CCLR2 to CCLR0	—	—	—	—	Other than B'001	B'001
Output function	—	Output compare output	—	PWM mode 1 output* ²	PWM mode 2 output	—

x: Don't care

Note: 2. TIOCB3 output is disabled.

8.4 Port 3

8.4.1 Overview

Port 3 is a 6-bit I/O port. Port 3 pins also function as SCI I/O pins (TxD0, RxD0, SCK0, TxD1, RxD1, and SCK1). Port 3 pin functions are the same in all operating modes.

Figure 8-3 shows the port 3 pin configuration.

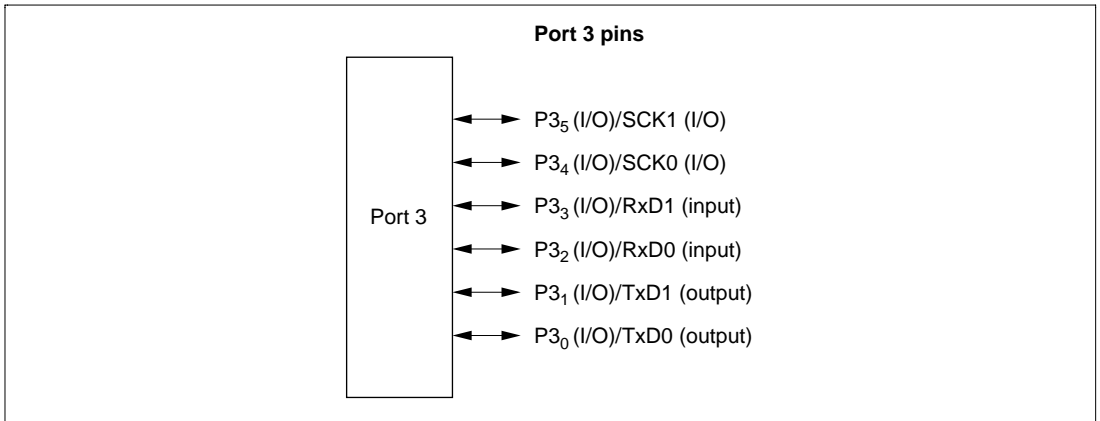

Figure 8-3 Port 3 Pin Functions

8.4.2 Register Configuration

Table 8-6 shows the port 3 register configuration.

Table 8-6 Port 3 Registers

Name	Abbreviation	R/W	Initial Value* ²	Address* ¹
Port 3 data direction register	P3DDR	W	H'00	H'FE2
Port 3 data register	P3DR	R/W	H'00	H'FF62
Port 3 register	PORT3	R	Undefined	H'FF52
Port 3 open drain control register	P3ODR	R/W	H'00	H'FF76

Notes: 1. Lower 16 bits of the address.

2. Value of bits 5 to 0.

Port 3 Data Direction Register (P3DDR)

Bit	:	7	6	5	4	3	2	1	0
		—	—	P35DDR	P34DDR	P33DDR	P32DDR	P31DDR	P30DDR
Initial value	:	Undefined	Undefined	0	0	0	0	0	0
R/W	:	—	—	W	W	W	W	W	W

P3DDR is an 8-bit write-only register, the individual bits of which specify input or output for the pins of port 3. Bits 7 and 6 are reserved. P3DDR cannot be read; if it is, an undefined value will be read.

Setting a P3DDR bit to 1 makes the corresponding port 3 pin an output pin, while clearing the bit to 0 makes the pin an input pin.

P3DDR is initialized to H'00 (bits 5 to 0) by a power-on reset, and in hardware standby mode. It retains its prior state after a manual reset, and in software standby mode. As the SCI is initialized, the pin states are determined by the P3DDR and P3DR specifications.

Port 3 Data Register (P3DR)

Bit	:	7	6	5	4	3	2	1	0
		—	—	P35DR	P34DR	P33DR	P32DR	P31DR	P30DR
Initial value	:	Undefined	Undefined	0	0	0	0	0	0
R/W	:	—	—	R/W	R/W	R/W	R/W	R/W	R/W

P3DR is an 8-bit readable/writable register that stores output data for the port 3 pins (P3₅ to P3₀).

Bits 7 and 6 are reserved; they return an undetermined value if read, and cannot be modified.

P3DR is initialized to H'00 (bits 5 to 0) by a power-on reset, and in hardware standby mode. It retains its prior state after a manual reset, and in software standby mode.

Port 3 Register (PORT3)

Bit	:	7	6	5	4	3	2	1	0
		—	—	P35	P34	P33	P32	P31	P30
Initial value	:	Undefined	Undefined	—*	—*	—*	—*	—*	—*
R/W	:	—	—	R	R	R	R	R	R

Note: * Determined by state of pins P3₅ to P3₀.

PORT3 is an 8-bit read-only register that shows the pin states. Writing of output data for the port 3 pins (P3₅ to P3₀) must always be performed on P3DR.

Bits 7 and 6 are reserved; they return an undetermined value if read, and cannot be modified.

If a port 3 read is performed while P3DDR bits are set to 1, the P3DR values are read. If a port 3 read is performed while P3DDR bits are cleared to 0, the pin states are read.

After a power-on reset and in hardware standby mode, PORT3 contents are determined by the pin states, as P3DDR and P3DR are initialized. PORT3 retains its prior state after a manual reset, and in software standby mode.

Port 3 Open Drain Control Register (P3ODR)

Bit	:	7	6	5	4	3	2	1	0
		—	—	P35ODR	P34ODR	P33ODR	P32ODR	P31ODR	P30ODR
Initial value	:	Undefined	Undefined	0	0	0	0	0	0
R/W	:	—	—	R/W	R/W	R/W	R/W	R/W	R/W

P3ODR is an 8-bit readable/writable register that controls the PMOS on/off status for each port 3 pin (P3₅ to P3₀).

Bits 7 and 6 are reserved; they return an undetermined value if read, and cannot be modified.

Setting a P3ODR bit to 1 makes the corresponding port 3 pin an NMOS open-drain output pin, while clearing the bit to 0 makes the pin a CMOS output pin.

P3ODR is initialized to H'00 (bits 5 to 0) by a power-on reset, and in hardware standby mode. It retains its prior state after a manual reset, and in software standby mode.

8.4.3 Pin Functions

Port 3 pins also function as SCI I/O pins (TxD0, RxD0, SCK0, TxD1, RxD1, and SCK1). Port 3 pin functions are shown in table 8-7.

Table 8-7 Port 3 Pin Functions

Pin	Selection Method and Pin Functions					
P3 ₅ /SCK1	The pin function is switched as shown below according to the combination of bit C/ \bar{A} in the SCI1 SMR, bits CKE0 and CKE1 in SCR, and bit P35DDR.					
	CKE1	0			1	
	C/ \bar{A}	0		1	—	
	CKE0	0	1	—	—	
	P35DDR	0	1	—	—	—
	Pin function	P3 ₅ input pin	P3 ₅ output pin*	SCK1 output pin*	SCK1 output pin*	SCK1 input pin

Note: * When P35ODR = 1, the pin becomes an NMOS open-drain output.

P3 ₄ /SCK0	The pin function is switched as shown below according to the combination of bit C/ \bar{A} in the SCI0 SMR, bits CKE0 and CKE1 in SCR, and bit P34DDR.					
	CKE1	0			1	
	C/ \bar{A}	0		1	—	
	CKE0	0	1	—	—	
	P34DDR	0	1	—	—	—
	Pin function	P3 ₄ input pin	P3 ₄ output pin*	SCK0 output pin*	SCK0 output pin*	SCK0 input pin

Note: * When P34ODR = 1, the pin becomes an NMOS open-drain output.

Pin**Selection Method and Pin Functions**P3₃/RxD1

The pin function is switched as shown below according to the combination of bit RE in the SCI1 SCR, and bit P33DDR.

RE	0		1
P33DDR	0	1	—
Pin function	P3 ₃ input pin	P3 ₃ output pin*	RxD1 input pin

Note: * When P33ODR = 1, the pin becomes an NMOS open-drain output.

P3₂/RxD0

The pin function is switched as shown below according to the combination of bit RE in the SCI0 SCR, and bit P32DDR.

RE	0		1
P32DDR	0	1	—
Pin function	P3 ₂ input pin	P3 ₂ output pin*	RxD0 input pin

Note: * When P32ODR = 1, the pin becomes an NMOS open-drain output.

P3₁/TxD1

The pin function is switched as shown below according to the combination of bit TE in the SCI1 SCR, and bit P31DDR.

TE	0		1
P31DDR	0	1	—
Pin function	P3 ₁ input pin	P3 ₁ output pin*	TxD1 output pin

Note: * When P31ODR = 1, the pin becomes an NMOS open-drain output.

P3₀/TxD0

The pin function is switched as shown below according to the combination of bit TE in the SCI0 SCR, and bit P30DDR.

TE	0		1
P30DDR	0	1	—
Pin function	P3 ₀ input pin	P3 ₀ output pin*	TxD0 output pin

Note: * When P30ODR = 1, the pin becomes an NMOS open-drain output.

8.5 Port 4

8.5.1 Overview

Port 4 is an 8-bit input-only port. Port 4 pins also function as A/D converter analog input pins (AN0 to AN7) and D/A converter analog output pins (DA0 and DA1) in the H8S/2355 and H8S/2353, and as A/D converter analog input pins (AN0 to AN7) in the H8S/2393. Port 4 pin functions are the same in all operating modes. Figure 8-4 shows the port 4 pin configuration.

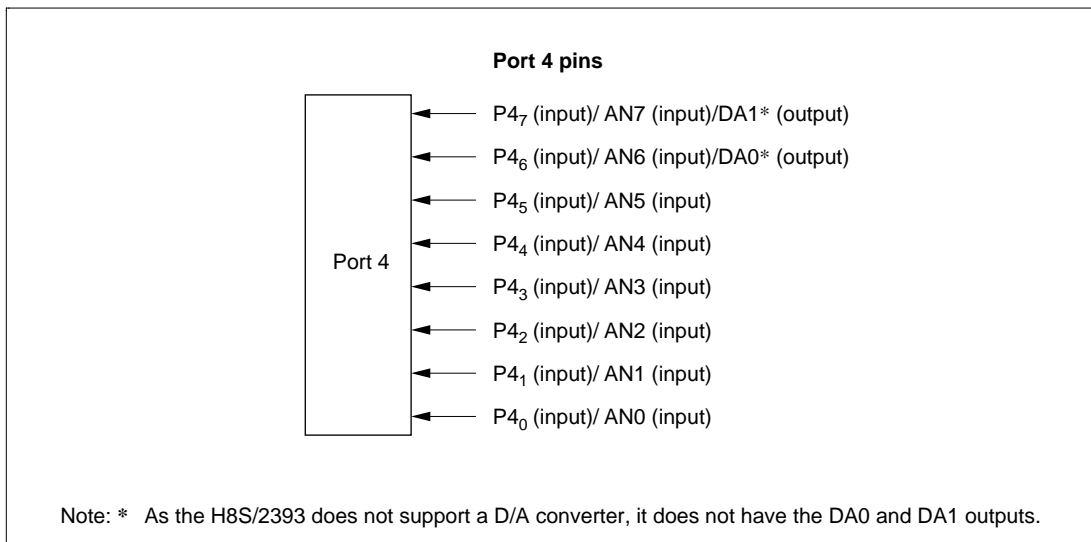

Figure 8-4 Port 4 Pin Functions

8.5.2 Register Configuration

Table 8-8 shows the port 4 register configuration. Port 4 is an input-only port, and does not have a data direction register or data register.

Table 8-8 Port 4 Registers

Name	Abbreviation	R/W	Initial Value	Address*
Port 4 register	PORT4	R	Undefined	H'FF53

Note: * Lower 16 bits of the address.

Port 4 Register (PORT4): The pin states are always read when a port 4 read is performed.

Bit	:	7	6	5	4	3	2	1	0
		P47	P46	P45	P44	P43	P42	P41	P40
Initial value	:	—*	—*	—*	—*	—*	—*	—*	—*
R/W	:	R	R	R	R	R	R	R	R

Note: * Determined by state of pins P47 to P40.

8.5.3 Pin Functions

- H8S/2355 and H8S/2353
Port 4 pins also function as A/D converter analog input pins (AN0 to AN7) and D/A converter analog output pins (DA0 and DA1).
- H8S/2393
Port 4 pins also function as A/D converter analog input pins (AN0 to AN7).

8.6 Port 5

8.6.1 Overview

Port 5 is a 4-bit I/O port. Port 5 pins also function as SCI I/O pins (TxD2, RxD2, and SCK2) and the A/D converter input pin ($\overline{\text{ADTRG}}$). Port 5 pin functions are the same in all operating modes. Figure 8-5 shows the port 5 pin configuration.

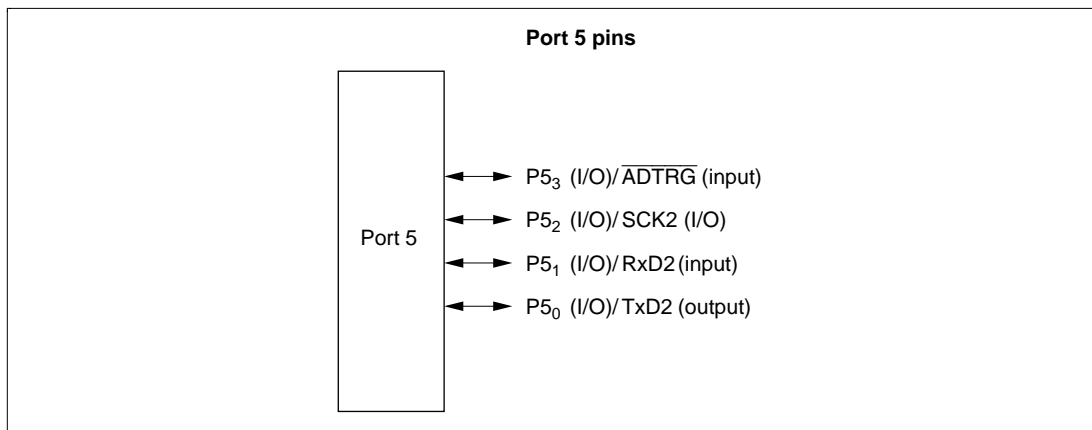

Figure 8-5 Port 5 Pin Functions

8.6.2 Register Configuration

Table 8-9 shows the port 5 register configuration.

Table 8-9 Port 5 Registers

Name	Abbreviation	R/W	Initial Value* ²	Address* ¹
Port 5 data direction register	P5DDR	W	H'0	H'FEB4
Port 5 data register	P5DR	R/W	H'0	H'FF64
Port 5 register	PORT5	R	Undefined	H'FF54

- Notes: 1. Lower 16 bits of the address.
2. Value of bits 3 to 0.

Port 5 Data Direction Register (P5DDR)

Bit	:	7	6	5	4	3	2	1	0
		—	—	—	—	P53DDR	P52DDR	P51DDR	P50DDR
Initial value	:	Undefined	Undefined	Undefined	Undefined	0	0	0	0
R/W	:	—	—	—	—	W	W	W	W

P5DDR is an 8-bit write-only register, the individual bits of which specify input or output for the pins of port 5. Bits 7 to 4 are reserved. P5DDR cannot be read; if it is, an undefined value will be read.

Setting a P5DDR bit to 1 makes the corresponding port 5 pin an output pin, while clearing the bit to 0 makes the pin an input pin.

P5DDR is initialized to H'0 (bits 3 to 0) by a power-on reset, and in hardware standby mode. It retains its prior state after a manual reset, and in software standby mode. As the SCI is initialized, the pin states are determined by the P5DDR and P5DR specifications.

Port 5 Data Register (P5DR)

Bit	:	7	6	5	4	3	2	1	0
		—	—	—	—	P53DR	P52DR	P51DR	P50DR
Initial value	:	Undefined	Undefined	Undefined	Undefined	0	0	0	0
R/W	:	—	—	—	—	R/W	R/W	R/W	R/W

P5DR is an 8-bit readable/writable register that stores output data for the port 5 pins (P5₃ to P5₀).

Bits 7 to 4 are reserved; they return an undetermined value if read, and cannot be modified.

P5DR is initialized to H'0 (bits 3 to 0) by a power-on reset, and in hardware standby mode. It retains its prior state after a manual reset, and in software standby mode.

Port 5 Register (PORT5)

Bit	:	7	6	5	4	3	2	1	0
		—	—	—	—	P53	P52	P51	P50
Initial value	:	Undefined	Undefined	Undefined	Undefined	—*	—*	—*	—*
R/W	:	—	—	—	—	R	R	R	R

Note: * Determined by state of pins P5₃ to P5₀.

PORT5 is an 8-bit read-only register that shows the pin states. It cannot be written to. Writing of output data for the port 5 pins (P5₃ to P5₀) must always be performed on P5DR.

Bits 7 to 4 are reserved; they return an undetermined value if read, and cannot be modified.

If a port 5 read is performed while P5DDR bits are set to 1, the P5DR values are read. If a port 5 read is performed while P5DDR bits are cleared to 0, the pin states are read.

After a power-on reset and in hardware standby mode, PORT5 contents are determined by the pin states, as P5DDR and P5DR are initialized. PORT5 retains its prior state after a manual reset, and in software standby mode.

8.6.3 Pin Functions

Port 5 pins also function as SCI I/O pins (TxD2, RxD2, and SCK2), and the A/D converter input pin ($\overline{\text{ADTRG}}$). Port 5 pin functions are shown in table 8-10.

Table 8-10 Port 5 Pin Functions

Pin Selection Method and Pin Functions

P5₃/ $\overline{\text{ADTRG}}$

The pin function is switched as shown below according to the combination of bits TRGS1 and TRGS0 in the A/D converter ADCR, and bit P53DDR.

P53DDR	0	1
Pin function	P5 ₃ input pin	P5 ₃ output pin
	$\overline{\text{ADTRG}}$ input pin*	

Note: * $\overline{\text{ADTRG}}$ input when TRGS0 = TRGS1 = 1.

P5₂/SCK2

The pin function is switched as shown below according to the combination of bit C/ $\overline{\text{A}}$ in the SCI2 SMR, bits CKE0 and CKE1 in SCR, and bit P52DDR.

CKE1	0			1	
C/ $\overline{\text{A}}$	0		1	—	
CKE0	0	1	—	—	
P52DDR	0	1	—	—	
Pin function	P5 ₂ input pin	P5 ₂ output pin	SCK2 output pin	SCK2 output pin	SCK2 input pin

P5₁/Rx/D2

The pin function is switched as shown below according to the combination of bit RE in the SCI2 SCR, and bit P51DDR.

RE	0		1
P51DDR	0	1	—
Pin function	P5 ₁ input pin	P5 ₁ output pin	RxD2 input pin

P5₀/Tx/D2

The pin function is switched as shown below according to the combination of bit TE in the SCI2 SCR, and bit P50DDR.

TE	0		1
P50DDR	0	1	—
Pin function	P5 ₀ input pin	P5 ₀ output pin	TxD2 output pin

8.7 Port 6

8.7.1 Overview

Port 6 is an 8-bit I/O port. Port 6 pins also function as interrupt input pins ($\overline{\text{IRQ0}}$ to $\overline{\text{IRQ3}}$) and bus control output pins ($\overline{\text{CS4}}$ to $\overline{\text{CS7}}$). The functions of pins P6_5 to P6_2 are the same in all operating modes, while the functions of pins P6_7 , P6_6 , P6_1 , and P6_0 change according to the operating mode. Pins P6_7 to P6_4 are schmitt-triggered inputs. Figure 8-6 shows the port 6 pin configuration.

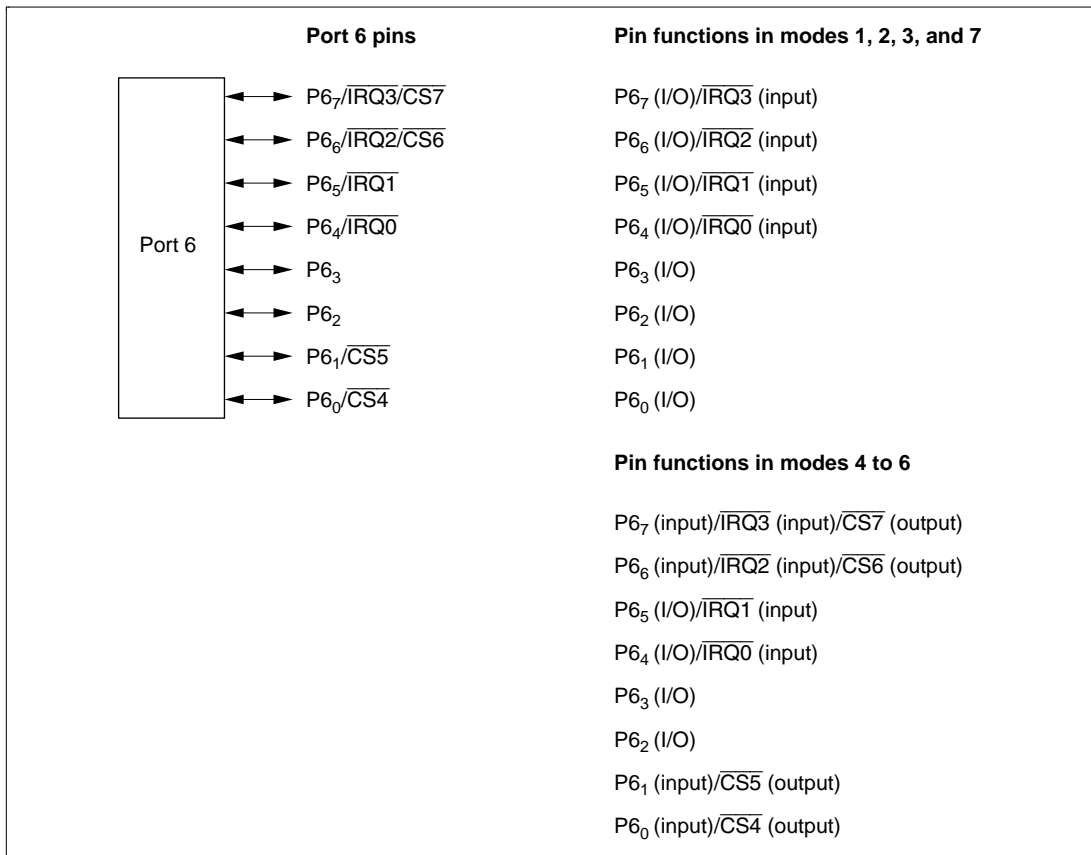

Figure 8-6 Port 6 Pin Functions

8.7.2 Register Configuration

Table 8-11 shows the port 6 register configuration.

Table 8-11 Port 6 Registers

Name	Abbreviation	R/W	Initial Value	Address*
Port 6 data direction register	P6DDR	W	H'00	H'FEB5
Port 6 data register	P6DR	R/W	H'00	H'FF65
Port 6 register	PORT6	R	Undefined	H'FF55

Note: * Lower 16 bits of the address.

Port 6 Data Direction Register (P6DDR)

Bit	:	7	6	5	4	3	2	1	0
		P67DDR	P66DDR	P65DDR	P64DDR	P63DDR	P62DDR	P61DDR	P60DDR
Initial value	:	0	0	0	0	0	0	0	0
R/W	:	W	W	W	W	W	W	W	W

P6DDR is an 8-bit write-only register, the individual bits of which specify input or output for the pins of port 6. P6DDR cannot be read; if it is, an undefined value will be read.

Setting a P6DDR bit to 1 makes the corresponding port 6 pin an output pin, while clearing the bit to 0 makes the pin an input pin.

P6DDR is initialized to H'00 by a power-on reset, and in hardware standby mode. It retains its prior state after a manual reset, and in software standby mode.

Port 6 Data Register (P6DR)

Bit	:	7	6	5	4	3	2	1	0
		P67DR	P66DR	P65DR	P64DR	P63DR	P62DR	P61DR	P60DR
Initial value	:	0	0	0	0	0	0	0	0
R/W	:	R/W	R/W	R/W	R/W	R/W	R/W	R/W	R/W

P6DR is an 8-bit readable/writable register that stores output data for the port 6 pins (P6₇ to P6₀).

P6DR is initialized to H'00 by a power-on reset, and in hardware standby mode. It retains its prior state after a manual reset, and in software standby mode.

Port 6 Register (PORT6)

Bit	:	7	6	5	4	3	2	1	0
		P67	P66	P65	P64	P63	P62	P61	P60
Initial value	:	—*	—*	—*	—*	—*	—*	—*	—*
RW	:	R	R	R	R	R	R	R	R

Note: * Determined by state of pins P6₇ to P6₀.

PORT6 is an 8-bit read-only register that shows the pin states. It cannot be written to. Writing of output data for the port 6 pins (P6₇ to P6₀) must always be performed on P6DR.

If a port 6 read is performed while P6DDR bits are set to 1, the P6DR values are read. If a port 6 read is performed while P6DDR bits are cleared to 0, the pin states are read.

After a power-on reset and in hardware standby mode, PORT6 contents are determined by the pin states, as P6DDR and P6DR are initialized. PORT6 retains its prior state after a manual reset, and in software standby mode.

8.7.3 Pin Functions

Port 6 pins also function as interrupt input pins ($\overline{\text{IRQ0}}$ to $\overline{\text{IRQ3}}$) and bus control output pins ($\overline{\text{CS4}}$ to $\overline{\text{CS7}}$). Port 6 pin functions are shown in table 8-12.

Table 8-12 Port 6 Pin Functions

Pin	Selection Method and Pin Functions			
$\text{P6}_7/\overline{\text{IRQ3}}/\overline{\text{CS7}}$	The pin function is switched as shown below according to bit P67DDR.			
	Modes 1, 2, 3, 7		Modes 4 to 6	
P67DDR	0	1	0	1
Pin function	P6_7 input pin	P6_7 output pin	P6_7 input pin	$\overline{\text{CS7}}$ output pin
	$\overline{\text{IRQ3}}$ interrupt input pin			
$\text{P6}_6/\overline{\text{IRQ2}}/\overline{\text{CS6}}$	The pin function is switched as shown below according to bit P66DDR.			
	Modes 1, 2, 3, 7		Modes 4 to 6	
P66DDR	0	1	0	1
Pin function	P6_6 input pin	P6_6 output pin	P6_6 input pin	$\overline{\text{CS6}}$ output pin
	$\overline{\text{IRQ2}}$ interrupt input pin			
$\text{P6}_5/\overline{\text{IRQ1}}$	The pin function is switched as shown below according to bit P65DDR.			
P65DDR	0		1	
Pin function	P6_5 input pin		P6_5 output pin	
	$\overline{\text{IRQ1}}$ interrupt input pin			
$\text{P6}_4/\overline{\text{IRQ0}}$	The pin function is switched as shown below according to bit P64DDR.			
P64DDR	0		1	
Pin function	P6_4 input pin		P6_4 output pin	
	$\overline{\text{IRQ0}}$ interrupt input pin			

Pin Selection Method and Pin Functions

$P6_3$ The pin function is switched as shown below according to bit P63DDR.

P63DDR	0	1
Pin function	$P6_3$ input pin	$P6_3$ output pin

$P6_2$ The pin function is switched as shown below according to bit P62DDR.

P62DDR	0	1
Pin function	$P6_2$ input pin	$P6_2$ output pin

$P6_1/\overline{CS5}$ The pin function is switched as shown below according to bit P61DDR.

Mode	Modes 1, 2, 3, 7		Modes 4 to 6	
P61DDR	0	1	0	1
Pin function	$P6_1$ input pin	$P6_1$ output pin	$P6_1$ input pin	$\overline{CS5}$ output pin

$P6_0/\overline{CS4}$ The pin function is switched as shown below according to bit P60DDR.

Mode	Modes 1, 2, 3, 7		Modes 4 to 6	
P60DDR	0	1	0	1
Pin function	$P6_0$ input pin	$P6_0$ output pin	$P6_0$ input pin	$\overline{CS4}$ output pin

8.8 Port A

8.8.1 Overview

Port A is an 8-bit I/O port. Port A pins also function as address bus outputs and interrupt input pins ($\overline{\text{IRQ}}4$ to $\overline{\text{IRQ}}7$). The pin functions change according to the operating mode.

Port A has a built-in MOS input pull-up function that can be controlled by software. Pins PA_7 to PA_4 are schmitt-triggered inputs.

Figure 8-7 shows the port A pin configuration.

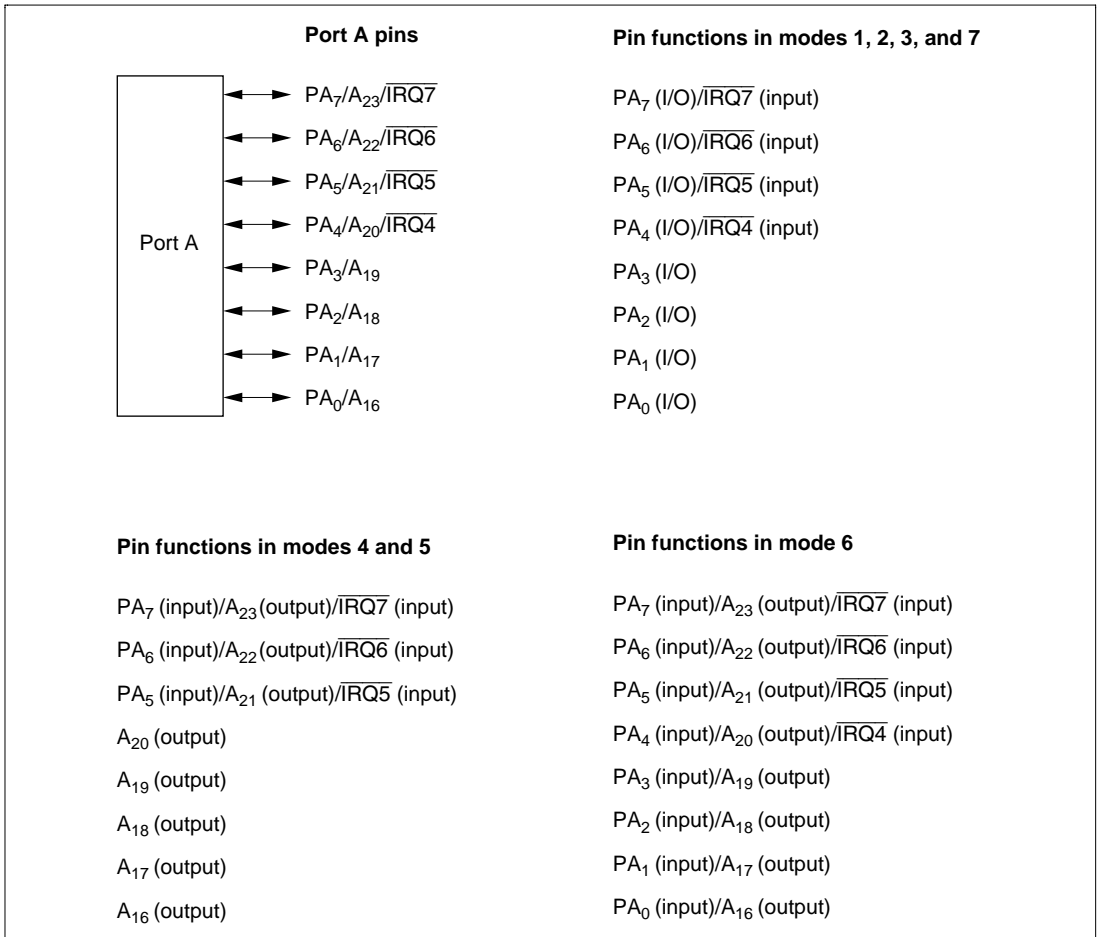

Figure 8-7 Port A Pin Functions

8.8.2 Register Configuration

Table 8-13 shows the port A register configuration.

Table 8-13 Port A Registers

Name	Abbreviation	R/W	Initial Value	Address *
Port A data direction register	PADDR	W	H'00	H'FEB9
Port A data register	PADR	R/W	H'00	H'FF69
Port A register	PORTA	R	Undefined	H'FF59
Port A MOS pull-up control register	PAPCR	R/W	H'00	H'FF70
Port A open-drain control register	PAODR	R/W	H'00	H'FF77

Note: * Lower 16 bits of the address.

Port A Data Direction Register (PADDR)

Bit	:	7	6	5	4	3	2	1	0
		PA7DDR	PA6DDR	PA5DDR	PA4DDR	PA3DDR	PA2DDR	PA1DDR	PA0DDR
Initial value	:	0	0	0	0	0	0	0	0
R/W	:	W	W	W	W	W	W	W	W

PADDR is an 8-bit write-only register, the individual bits of which specify input or output for the pins of port A. PADDR cannot be read; if it is, an undefined value will be read.

PADDR is initialized to H'00 by a power-on reset and in hardware standby mode. It retains its prior state after a manual reset, and in software standby mode. The OPE bit in SBYCR is used to select whether the address output pins retain their output state or become high-impedance when a transition is made to software standby mode.

- Modes 1, 2, 3, and 7

Setting a PADDR bit to 1 makes the corresponding port A pin an output port, while clearing the bit to 0 makes the pin an input port.

- Modes 4 and 5

The corresponding port A pins are address outputs irrespective of the value of bits PA4DDR to PA0DDR.

Setting one of bits PA7DDR to PA5DDR to 1 makes the corresponding port A pin an address output, while clearing the bit to 0 makes the pin an input port.

- Mode 6

Setting a PADDR bit to 1 makes the corresponding port A pin an address output while clearing the bit to 0 makes the pin an input port.

Port A Data Register (PADR)

Bit	:	7	6	5	4	3	2	1	0
		PA7DR	PA6DR	PA5DR	PA4DR	PA3DR	PA2DR	PA1DR	PA0DR
Initial value	:	0	0	0	0	0	0	0	0
R/W	:	R/W	R/W	R/W	R/W	R/W	R/W	R/W	R/W

PADR is an 8-bit readable/writable register that stores output data for the port A pins (PA₇ to PA₀).

PADR is initialized to H'00 by a power-on reset, and in hardware standby mode. It retains its prior state after a manual reset, and in software standby mode.

Port A Register (PORTA)

Bit	:	7	6	5	4	3	2	1	0
		PA7	PA6	PA5	PA4	PA3	PA2	PA1	PA0
Initial value	:	—*	—*	—*	—*	—*	—*	—*	—*
R/W	:	R	R	R	R	R	R	R	R

Note: * Determined by state of pins PA₇ to PA₀.

PORTA is an 8-bit read-only register that shows the pin states. It cannot be written to. Writing of output data for the port A pins (PA₇ to PA₀) must always be performed on PADR.

If a port A read is performed while PADDR bits are set to 1, the PADR values are read. If a port A read is performed while PADDR bits are cleared to 0, the pin states are read.

After a power-on reset and in hardware standby mode, PORTA contents are determined by the pin states, as PADDR and PADR are initialized. PORTA retains its prior state after a manual reset, and in software standby mode.

Port A MOS Pull-Up Control Register (PAPCR)

Bit	:	7	6	5	4	3	2	1	0
		PA7PCR	PA6PCR	PA5PCR	PA4PCR	PA3PCR	PA2PCR	PA1PCR	PA0PCR
Initial value	:	0	0	0	0	0	0	0	0
R/W	:	R/W	R/W	R/W	R/W	R/W	R/W	R/W	R/W

PAPCR is an 8-bit readable/writable register that controls the MOS input pull-up function incorporated into port A on an individual bit basis.

All the bits are valid in modes 1, 2, 3, 6, and 7, and bits 7 to 5 are valid in modes 4 and 5. When a PADDR bit is cleared to 0 (input port setting), setting the corresponding PAPCR bit to 1 turns on the MOS input pull-up for the corresponding pin.

PAPCR is initialized to H'00 by a power-on reset, and in hardware standby mode. It retains its prior state after a manual reset, and in software standby mode.

Port A Open Drain Control Register (PAODR)

Bit	:	7	6	5	4	3	2	1	0
		PA7ODR	PA6ODR	PA5ODR	PA4ODR	PA3ODR	PA2ODR	PA1ODR	PA0ODR
Initial value	:	0	0	0	0	0	0	0	0
R/W	:	R/W	R/W	R/W	R/W	R/W	R/W	R/W	R/W

PAODR is an 8-bit readable/writable register that controls whether PMOS is on or off for each port A pin (PA₇ to PA₀).

All bits are valid in modes 1, 2, 3, and 7.

Setting a PAODR bit to 1 makes the corresponding port A pin an NMOS open-drain output, while clearing the bit to 0 makes the pin a CMOS output.

PAODR is initialized to H'00 by a power-on reset, and in hardware standby mode. It retains its prior state after a manual reset, and in software standby mode.

8.8.3 Pin Functions

Modes 1, 2, 3 and 7: In mode 1, 2, 3, and 7, port A pins function as I/O ports and interrupt input pins. Input or output can be specified for each pin on an individual bit basis. Setting a PADDR bit to 1 makes the corresponding port A pin an output port, while clearing the bit to 0 makes the pin an input port.

Port A pin functions in modes 1, 2, 3, and 7 are shown in figure 8-8.

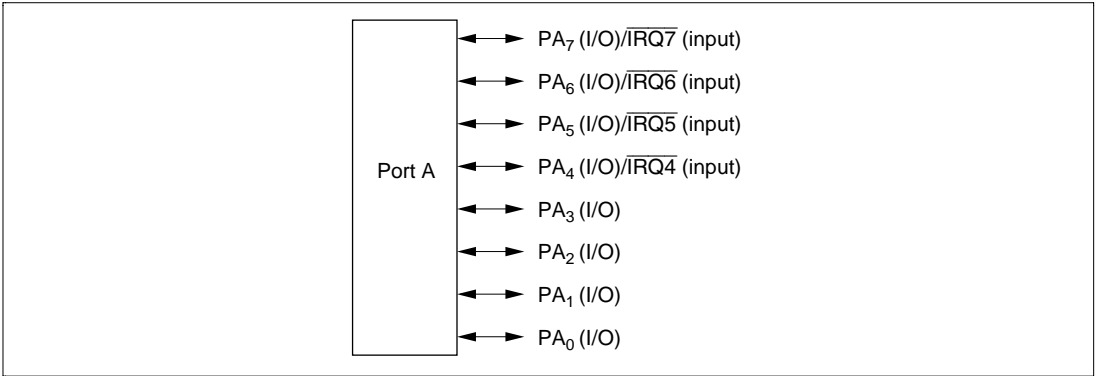

Figure 8-8 Port A Pin Functions (Modes 1, 2, 3, and 7)

Modes 4 and 5: In modes 4 and 5, the lower 5 bits of port A are designated as address outputs automatically, while the upper 3 bits function as address outputs or input ports and interrupt input pins. Input or output can be specified individually for the upper 3 bits. Setting one of bits PA7DDR to PA5DDR to 1 makes the corresponding port A pin an address output, while clearing the bit to 0 makes the pin an input port.

Port A pin functions in modes 4 and 5 are shown in figure 8-9.

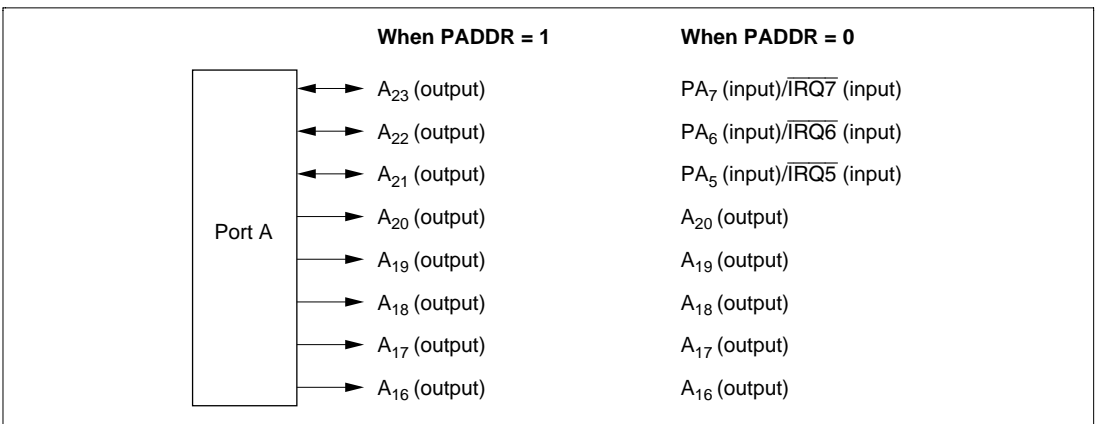

Figure 8-9 Port A Pin Functions (Modes 4 and 5)

Mode 6: In mode 6, port A pins function as address outputs or input ports and interrupt input pins. Input or output can be specified on an individual bit basis. Setting a PADDR bit to 1 makes the corresponding port A pin an address output, while clearing the bit to 0 makes the pin an input port.

Port A pin functions in mode 6 are shown in figure 8-10.

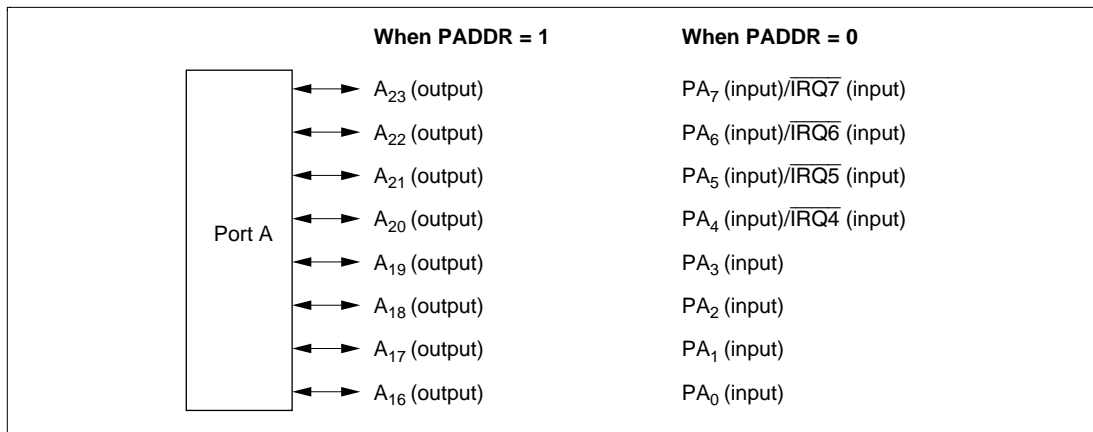

Figure 8-10 Port A Pin Functions (Mode 6)

8.8.4 MOS Input Pull-Up Function

Port A has a built-in MOS input pull-up function that can be controlled by software. This MOS input pull-up function can be used by pins PA₇ to PA₅ in modes 4 and 5, and by all pins in modes 1, 2, 3, 6, and 7. MOS input pull-up can be specified as on or off on an individual bit basis.

When a PADDR bit is cleared to 0, setting the corresponding PAPCR bit to 1 turns on the MOS input pull-up for that pin.

The MOS input pull-up function is in the off state after a power-on reset, and in hardware standby mode. The prior state is retained after a manual reset, and in software standby mode.

Table 8-14 summarizes the MOS input pull-up states.

Table 8-14 MOS Input Pull-Up States (Port A)

Modes	Power-On Reset	Hardware Standby Mode	Manual Reset	Software Standby Mode	In Other Operations
1 to 3, 6, 7	PA ₇ to PA ₀	OFF	ON/OFF		
4, 5	PA ₇ to PA ₅		ON/OFF		
	PA ₄ to PA ₀		OFF		

Legend:

OFF : MOS input pull-up is always off.

ON/OFF : On when PADDR = 0 and PAPCR = 1; otherwise off.

8.9 Port B

8.9.1 Overview

Port B is an 8-bit I/O port. Port B has an address bus output function, and the pin functions change according to the operating mode.

Port B has a built-in MOS input pull-up function that can be controlled by software.

Figure 8-11 shows the port B pin configuration.

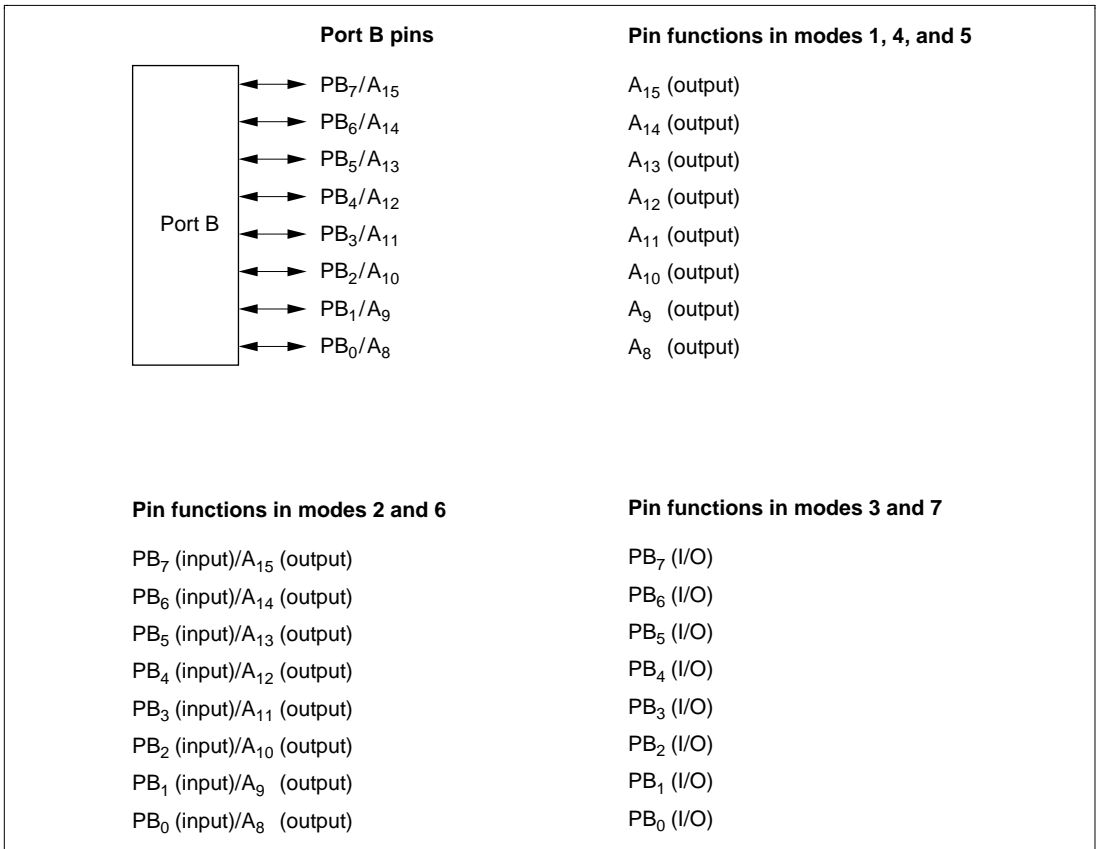

Figure 8-11 Port B Pin Functions

8.9.2 Register Configuration

Table 8-15 shows the port B register configuration.

Table 8-15 Port B Registers

Name	Abbreviation	R/W	Initial Value	Address *
Port B data direction register	PBDDR	W	H'00	H'FEBA
Port B data register	PBDR	R/W	H'00	H'FF6A
Port B register	PORTB	R	Undefined	H'FF5A
Port B MOS pull-up control register	PBPCR	R/W	H'00	H'FF71

Note: * Lower 16 bits of the address.

Port B Data Direction Register (PBDDR)

Bit	:	7	6	5	4	3	2	1	0
		PB7DDR	PB6DDR	PB5DDR	PB4DDR	PB3DDR	PB2DDR	PB1DDR	PB0DDR
Initial value	:	0	0	0	0	0	0	0	0
R/W	:	W	W	W	W	W	W	W	W

PBDDR is an 8-bit write-only register, the individual bits of which specify input or output for the pins of port B. PBDDR cannot be read; if it is, an undefined value will be read.

PBDDR is initialized to H'00 by a power-on reset and in hardware standby mode. It retains its prior state after a manual reset, and in software standby mode. The OPE bit in SBYCR is used to select whether the address output pins retain their output state or become high-impedance when a transition is made to software standby mode.

- Modes 1, 4, and 5
The corresponding port B pins are address outputs irrespective of the value of the PBDDR bits.
- Modes 2 and 6
Setting a PBDDR bit to 1 makes the corresponding port B pin an address output, while clearing the bit to 0 makes the pin an input port.
- Modes 3 and 7
Setting a PBDDR bit to 1 makes the corresponding port B pin an output port, while clearing the bit to 0 makes the pin an input port.

Port B Data Register (PBDR)

Bit	:	7	6	5	4	3	2	1	0
		PB7DR	PB6DR	PB5DR	PB4DR	PB3DR	PB2DR	PB1DR	PB0DR
Initial value	:	0	0	0	0	0	0	0	0
R/W	:	R/W	R/W	R/W	R/W	R/W	R/W	R/W	R/W

PBDR is an 8-bit readable/writable register that stores output data for the port B pins (PB₇ to PB₀). PBDR is initialized to H'00 by a power-on reset, and in hardware standby mode. It retains its prior state after a manual reset, and in software standby mode.

Port B Register (PORTB)

Bit	:	7	6	5	4	3	2	1	0
		PB7	PB6	PB5	PB4	PB3	PB2	PB1	PB0
Initial value	:	—*	—*	—*	—*	—*	—*	—*	—*
R/W	:	R	R	R	R	R	R	R	R

Note: * Determined by state of pins PB₇ to PB₀.

PORTB is an 8-bit read-only register that shows the pin states. It cannot be written to. Writing of output data for the port B pins (PB₇ to PB₀) must always be performed on PBDR.

If a port B read is performed while PBDDR bits are set to 1, the PBDR values are read. If a port B read is performed while PBDDR bits are cleared to 0, the pin states are read.

After a power-on reset and in hardware standby mode, PORTB contents are determined by the pin states, as PBDDR and PBDR are initialized. PORTB retains its prior state after a manual reset, and in software standby mode.

Port B MOS Pull-Up Control Register (PBPCR)

Bit	:	7	6	5	4	3	2	1	0
		PB7PCR	PB6PCR	PB5PCR	PB4PCR	PB3PCR	PB2PCR	PB1PCR	PB0PCR
Initial value	:	0	0	0	0	0	0	0	0
R/W	:	R/W	R/W	R/W	R/W	R/W	R/W	R/W	R/W

PBPCR is an 8-bit readable/writable register that controls the MOS input pull-up function incorporated into port B on an individual bit basis.

When a PBDDR bit is cleared to 0 (input port setting) in mode 2, 3, 6, or 7, setting the corresponding PBPCR bit to 1 turns on the MOS input pull-up for the corresponding pin.

PBPCR is initialized to H'00 by a power-on reset, and in hardware standby mode. It retains its prior state after a manual reset, and in software standby mode.

8.9.3 Pin Functions

Modes 1, 4, and 5: In modes 1, 4, and 5, port B pins are automatically designated as address outputs.

Port B pin functions in modes 1, 4, and 5 are shown in figure 8-12.

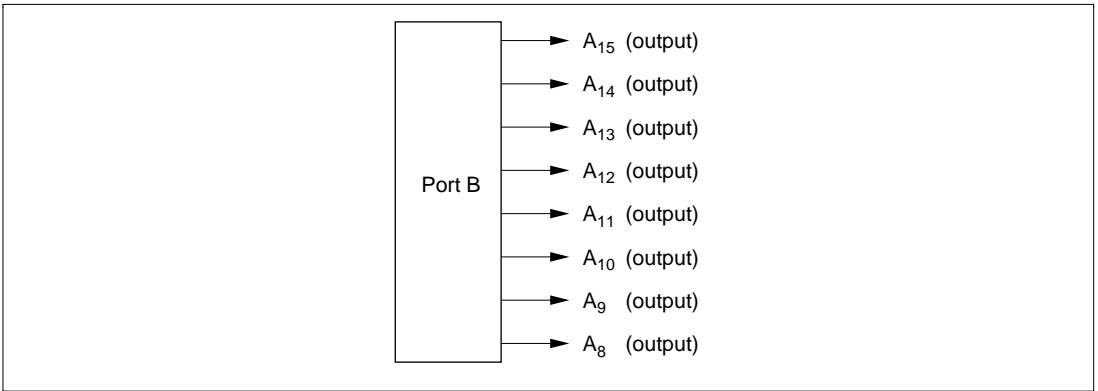

Figure 8-12 Port B Pin Functions (Modes 1, 4, and 5)

Modes 2 and 6: In modes 2 and 6, port B pins function as address outputs or input ports. Input or output can be specified on an individual bit basis. Setting a PBDDR bit to 1 makes the corresponding port B pin an address output, while clearing the bit to 0 makes the pin an input port.

Port B pin functions in modes 2 and 6 are shown in figure 8-13.

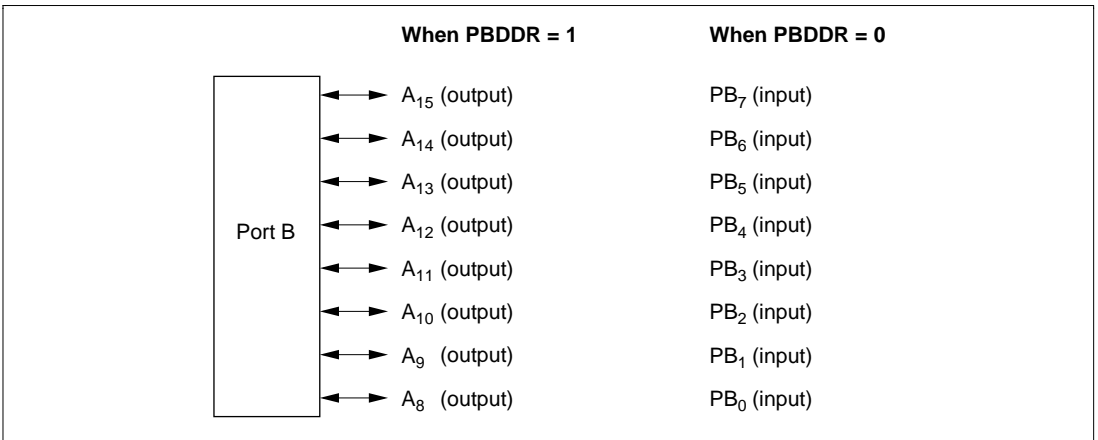

Figure 8-13 Port B Pin Functions (Modes 2 and 6)

Modes 3 and 7: In modes 3 and 7, port B pins function as I/O ports. Input or output can be specified for each pin on an individual bit basis. Setting a PBDDR bit to 1 makes the corresponding port B pin an output port, while clearing the bit to 0 makes the pin an input port.

Port B pin functions in modes 3 and 7 are shown in figure 8-14.

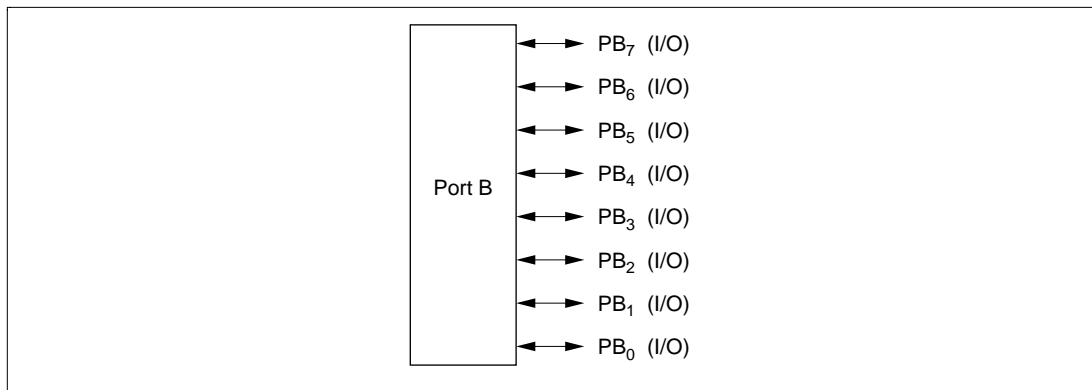

Figure 8-14 Port B Pin Functions (Modes 3 and 7)

8.9.4 MOS Input Pull-Up Function

Port B has a built-in MOS input pull-up function that can be controlled by software. This MOS input pull-up function can be used in modes 2, 3, 6, and 7, and can be specified as on or off on an individual bit basis.

When a PBDDR bit is cleared to 0 in mode 2, 3, 6, or 7, setting the corresponding PBPCR bit to 1 turns on the MOS input pull-up for that pin.

The MOS input pull-up function is in the off state after a power-on reset, and in hardware standby mode. The prior state is retained after a manual reset, and in software standby mode.

Table 8-16 summarizes the MOS input pull-up states.

Table 8-16 MOS Input Pull-Up States (Port B)

Modes	Power-On Reset	Hardware Standby Mode	Manual Reset	Software Standby Mode	In Other Operations
1, 4, 5	OFF		OFF		
2, 3, 6, 7			ON/OFF		

Legend:

OFF : MOS input pull-up is always off.

ON/OFF : On when PBDDR = 0 and PBPCR = 1; otherwise off.

8.10 Port C

8.10.1 Overview

Port C is an 8-bit I/O port. Port C has an address bus output function, and the pin functions change according to the operating mode.

Port C has a built-in MOS input pull-up function that can be controlled by software.

Figure 8-15 shows the port C pin configuration.

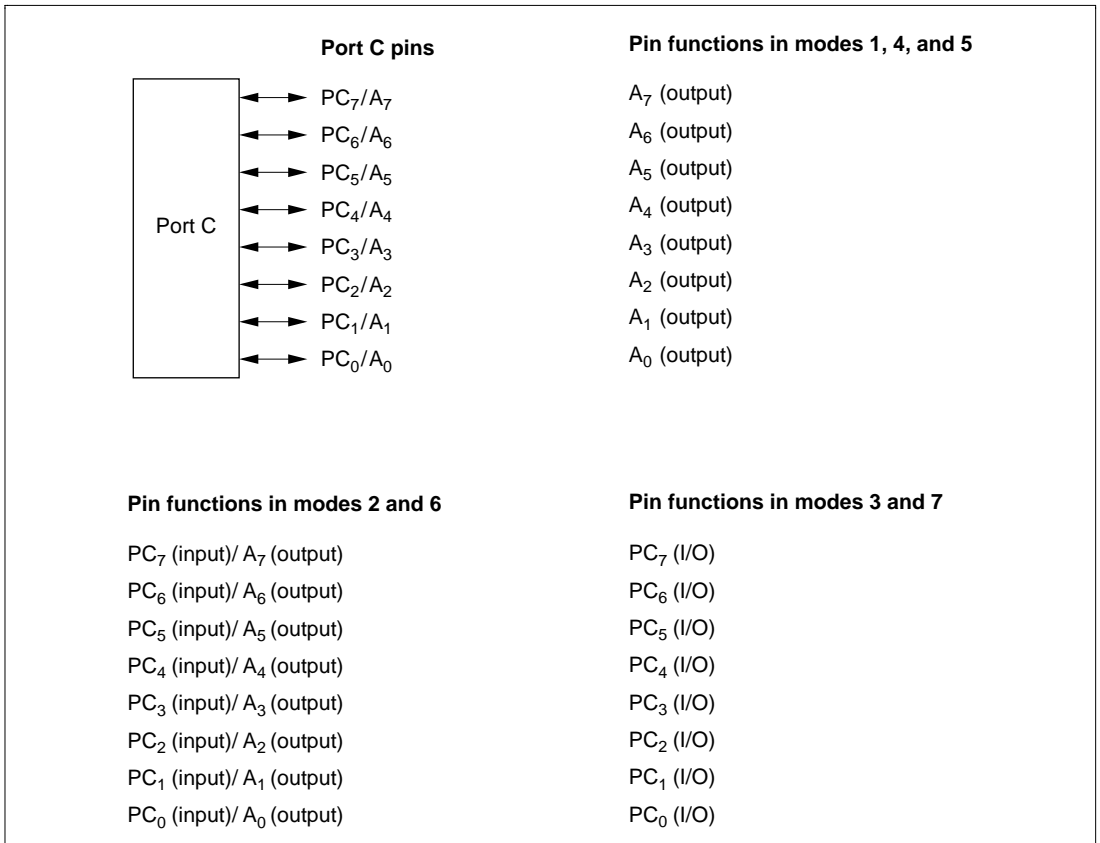

Figure 8-15 Port C Pin Functions

8.10.2 Register Configuration

Table 8-17 shows the port C register configuration.

Table 8-17 Port C Registers

Name	Abbreviation	R/W	Initial Value	Address *
Port C data direction register	PCDDR	W	H'00	H'FEBB
Port C data register	PCDR	R/W	H'00	H'FF6B
Port C register	PORTC	R	Undefined	H'FF5B
Port C MOS pull-up control register	PCPCR	R/W	H'00	H'FF72

Note: * Lower 16 bits of the address.

Port C Data Direction Register (PCDDR)

Bit	:	7	6	5	4	3	2	1	0
		PC7DDR	PC6DDR	PC5DDR	PC4DDR	PC3DDR	PC2DDR	PC1DDR	PC0DDR
Initial value	:	0	0	0	0	0	0	0	0
R/W	:	W	W	W	W	W	W	W	W

PCDDR is an 8-bit write-only register, the individual bits of which specify input or output for the pins of port C. PCDDR cannot be read; if it is, an undefined value will be read.

PCDDR is initialized to H'00 by a power-on reset and in hardware standby mode. It retains its prior state after a manual reset, and in software standby mode. The OPE bit in SBYCR is used to select whether the address output pins retain their output state or become high-impedance when a transition is made to software standby mode.

- Modes 1, 4, and 5

The corresponding port C pins are address outputs irrespective of the value of the PCDDR bits.

- Modes 2 and 6

Setting a PCDDR bit to 1 makes the corresponding port C pin an address output, while clearing the bit to 0 makes the pin an input port.

- Modes 3 and 7

Setting a PCDDR bit to 1 makes the corresponding port C pin an output port, while clearing the bit to 0 makes the pin an input port.

Port C Data Register (PCDR)

Bit	:	7	6	5	4	3	2	1	0
		PC7DR	PC6DR	PC5DR	PC4DR	PC3DR	PC2DR	PC1DR	PC0DR
Initial value	:	0	0	0	0	0	0	0	0
R/W	:	R/W	R/W	R/W	R/W	R/W	R/W	R/W	R/W

PCDR is an 8-bit readable/writable register that stores output data for the port C pins (PC₇ to PC₀).

PCDR is initialized to H'00 by a power-on reset, and in hardware standby mode. It retains its prior state after a manual reset, and in software standby mode.

Port C Register (PORTC)

Bit	:	7	6	5	4	3	2	1	0
		PC7	PC6	PC5	PC4	PC3	PC2	PC1	PC0
Initial value	:	—*	—*	—*	—*	—*	—*	—*	—*
R/W	:	R	R	R	R	R	R	R	R

Note: * Determined by state of pins PC₇ to PC₀.

PORTC is an 8-bit read-only register that shows the pin states. It cannot be written to. Writing of output data for the port C pins (PC₇ to PC₀) must always be performed on PCDR.

If a port C read is performed while PCDDR bits are set to 1, the PCDR values are read. If a port C read is performed while PCDDR bits are cleared to 0, the pin states are read.

After a power-on reset and in hardware standby mode, PORTC contents are determined by the pin states, as PCDDR and PCDR are initialized. PORTC retains its prior state after a manual reset, and in software standby mode.

Port C MOS Pull-Up Control Register (PCPCR)

Bit	:	7	6	5	4	3	2	1	0
		PC7PCR	PC6PCR	PC5PCR	PC4PCR	PC3PCR	PC2PCR	PC1PCR	PC0PCR
Initial value	:	0	0	0	0	0	0	0	0
R/W	:	R/W	R/W	R/W	R/W	R/W	R/W	R/W	R/W

PCPCR is an 8-bit readable/writable register that controls the MOS input pull-up function incorporated into port C on an individual bit basis.

When a PCDDR bit is cleared to 0 (input port setting) in mode 2, 3, 6, or 7, setting the corresponding PCPCR bit to 1 turns on the MOS input pull-up for the corresponding pin.

PCPCR is initialized to H'00 by a power-on reset, and in hardware standby mode. It retains its prior state after a manual reset, and in software standby mode.

8.10.3 Pin Functions

Modes 1, 4, and 5: In modes 1, 4, and 5, port C pins are automatically designated as address outputs.

Port C pin functions in modes 1, 4, and 5 are shown in figure 8-16.

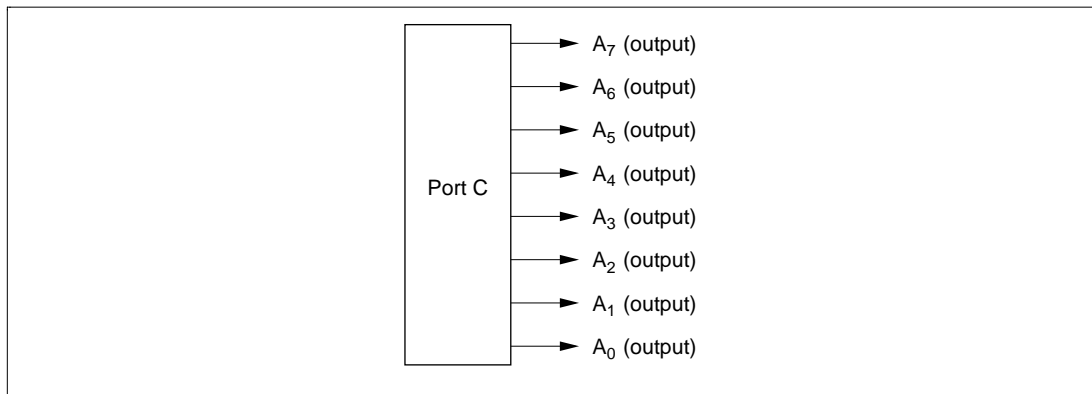

Figure 8-16 Port C Pin Functions (Modes 1, 4, and 5)

Modes 2 and 6: In modes 2 and 6, port C pins function as address outputs or input ports. Input or output can be specified on an individual bit basis. Setting a PCDDR bit to 1 makes the corresponding port C pin an address output, while clearing the bit to 0 makes the pin an input port.

Port C pin functions in modes 2 and 6 are shown in figure 8-17.

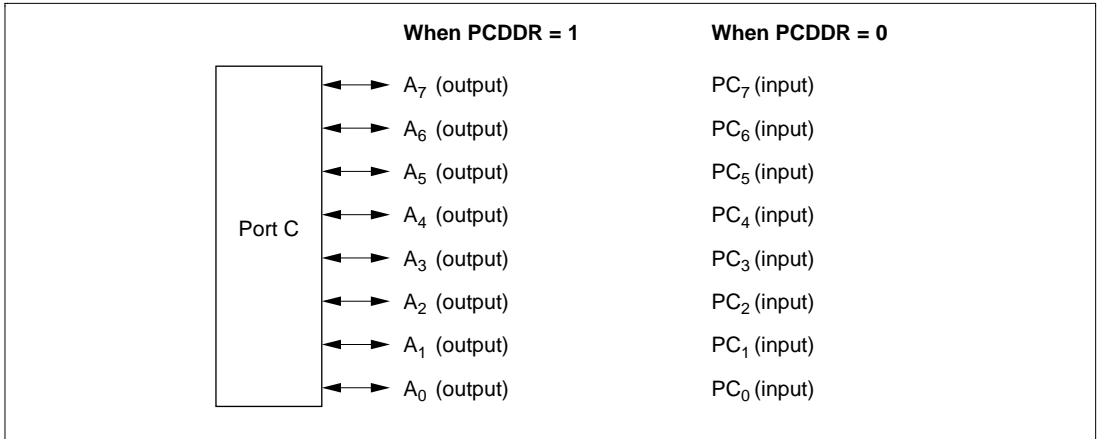

Figure 8-17 Port C Pin Functions (Modes 2 and 6)

Modes 3 and 7: In modes 3 and 7, port C pins function as I/O ports. Input or output can be specified for each pin on an individual bit basis. Setting a PCDDR bit to 1 makes the corresponding port C pin an output port, while clearing the bit to 0 makes the pin an input port.

Port C pin functions in modes 3 and 7 are shown in figure 8-18.

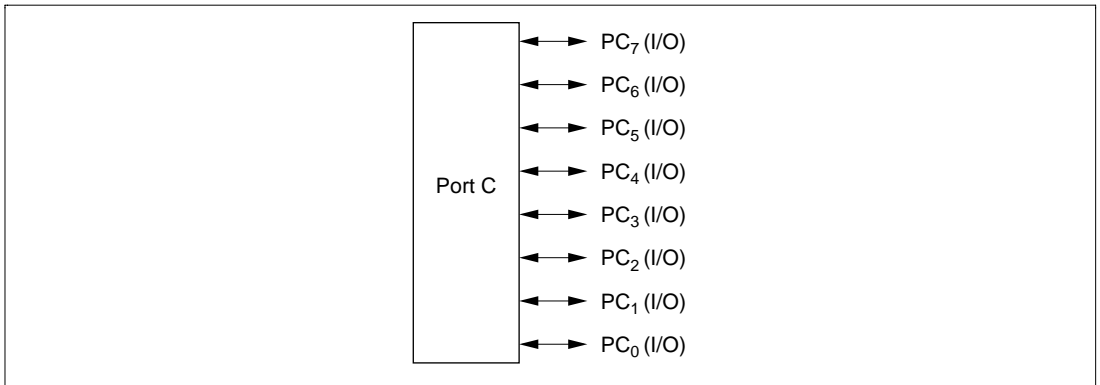

Figure 8-18 Port C Pin Functions (Modes 3 and 7)

8.10.4 MOS Input Pull-Up Function

Port C has a built-in MOS input pull-up function that can be controlled by software. This MOS input pull-up function can be used in modes 2, 3, 6, and 7, and can be specified as on or off on an individual bit basis.

When a PCDDR bit is cleared to 0 in mode 2, 3, 6, or 7, setting the corresponding PCPCR bit to 1 turns on the MOS input pull-up for that pin.

The MOS input pull-up function is in the off state after a power-on reset, and in hardware standby mode. The prior state is retained after a manual reset, and in software standby mode.

Table 8-18 summarizes the MOS input pull-up states.

Table 8-18 MOS Input Pull-Up States (Port C)

Modes	Power-On Reset	Hardware Standby Mode	Manual Reset	Software Standby Mode	In Other Operations
1, 4, 5	OFF		OFF		
2, 3, 6, 7			ON/OFF		

Legend:

OFF : MOS input pull-up is always off.

ON/OFF : On when PCDDR = 0 and PCPCR = 1; otherwise off.

8.11 Port D

8.11.1 Overview

Port D is an 8-bit I/O port. Port D has a data bus I/O function, and the pin functions change according to the operating mode.

Port D has a built-in MOS input pull-up function that can be controlled by software.

Figure 8-19 shows the port D pin configuration.

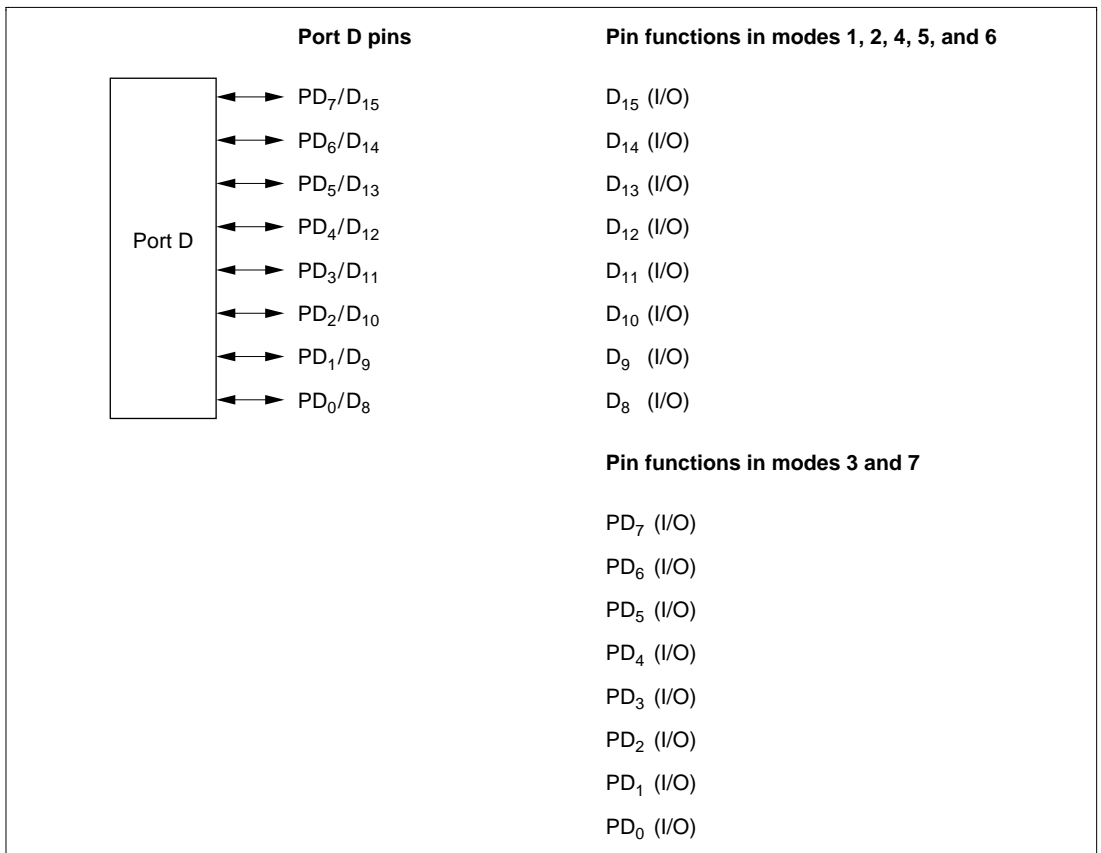

Figure 8-19 Port D Pin Functions

8.11.2 Register Configuration

Table 8-19 shows the port D register configuration.

Table 8-19 Port D Registers

Name	Abbreviation	R/W	Initial Value	Address *
Port D data direction register	PDDDR	W	H'00	H'FEBC
Port D data register	PDDR	R/W	H'00	H'FF6C
Port D register	PORTD	R	Undefined	H'FF5C
Port D MOS pull-up control register	PDPCR	R/W	H'00	H'FF73

Note: * Lower 16 bits of the address.

Port D Data Direction Register (PDDDR)

Bit	:	7	6	5	4	3	2	1	0
		PD7DDR	PD6DDR	PD5DDR	PD4DDR	PD3DDR	PD2DDR	PD1DDR	PD0DDR
Initial value	:	0	0	0	0	0	0	0	0
R/W	:	W	W	W	W	W	W	W	W

PDDDR is an 8-bit write-only register, the individual bits of which specify input or output for the pins of port D. PDDDR cannot be read; if it is, an undefined value will be read..

PDDDR is initialized to H'00 by a power-on reset, and in hardware standby mode. It retains its prior state after a manual reset, and in software standby mode.

- Modes 1, 2, 4, 5, and 6

The input/output direction specification by PDDDR is ignored, and port D is automatically designated for data I/O.

- Modes 3 and 7

Setting a PDDDR bit to 1 makes the corresponding port D pin an output port, while clearing the bit to 0 makes the pin an input port.

Port D Data Register (PDDR)

Bit	:	7	6	5	4	3	2	1	0
		PD7DR	PD6DR	PD5DR	PD4DR	PD3DR	PD2DR	PD1DR	PD0DR
Initial value	:	0	0	0	0	0	0	0	0
R/W	:	R/W	R/W	R/W	R/W	R/W	R/W	R/W	R/W

PDDR is an 8-bit readable/writable register that stores output data for the port D pins (PD₇ to PD₀).

PDDR is initialized to H'00 by a power-on reset, and in hardware standby mode. It retains its prior state after a manual reset, and in software standby mode.

Port D Register (PORTD)

Bit	:	7	6	5	4	3	2	1	0
		PD7	PD6	PD5	PD4	PD3	PD2	PD1	PD0
Initial value	:	—*	—*	—*	—*	—*	—*	—*	—*
R/W	:	R	R	R	R	R	R	R	R

Note: * Determined by state of pins PD₇ to PD₀.

PORTD is an 8-bit read-only register that shows the pin states. It cannot be written to. Writing of output data for the port D pins (PD₇ to PD₀) must always be performed on PDDR.

If a port D read is performed while PDDDR bits are set to 1, the PDDR values are read. If a port D read is performed while PDDDR bits are cleared to 0, the pin states are read.

After a power-on reset and in hardware standby mode, PORTD contents are determined by the pin states, as PDDDR and PDDR are initialized. PORTD retains its prior state after a manual reset, and in software standby mode.

Port D MOS Pull-Up Control Register (PDPCR)

Bit	:	7	6	5	4	3	2	1	0
		PD7PCR	PD6PCR	PD5PCR	PD4PCR	PD3PCR	PD2PCR	PD1PCR	PD0PCR
Initial value	:	0	0	0	0	0	0	0	0
R/W	:	R/W	R/W	R/W	R/W	R/W	R/W	R/W	R/W

PDPCR is an 8-bit readable/writable register that controls the MOS input pull-up function incorporated into port D on an individual bit basis.

When a PDDDR bit is cleared to 0 (input port setting) in mode 3 or 7, setting the corresponding PDPCR bit to 1 turns on the MOS input pull-up for the corresponding pin.

PDPCR is initialized to H'00 by a power-on reset, and in hardware standby mode. It retains its prior state after a manual reset, and in software standby mode.

8.11.3 Pin Functions

Modes 1, 2, 4, 5, and 6: In modes 1, 2, 4, 5, and 6, port D pins are automatically designated as data I/O pins.

Port D pin functions in modes 1, 2, 4, 5, and 6 are shown in figure 8-20.

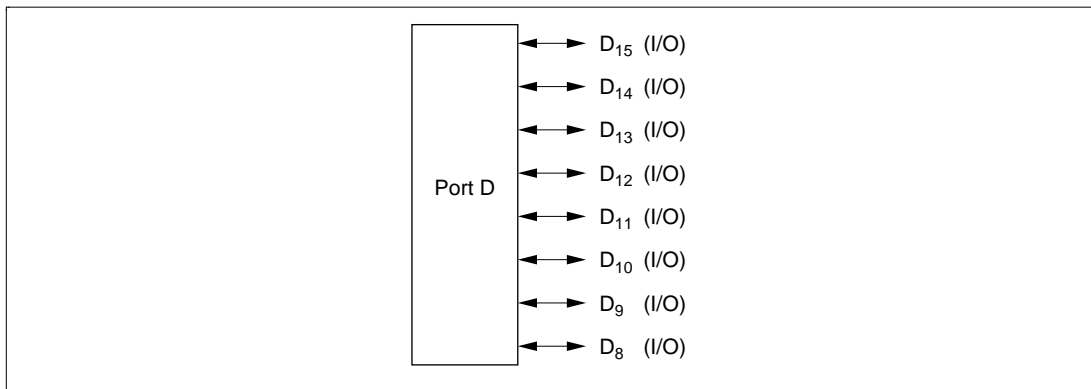

Figure 8-20 Port D Pin Functions (Modes 1, 2, 4, 5, and 6)

Modes 3 and 7: In modes 3 and 7, port D pins function as I/O ports. Input or output can be specified for each pin on an individual bit basis. Setting a PDDDR bit to 1 makes the corresponding port D pin an output port, while clearing the bit to 0 makes the pin an input port.

Port D pin functions in modes 3 and 7 are shown in figure 8-21.

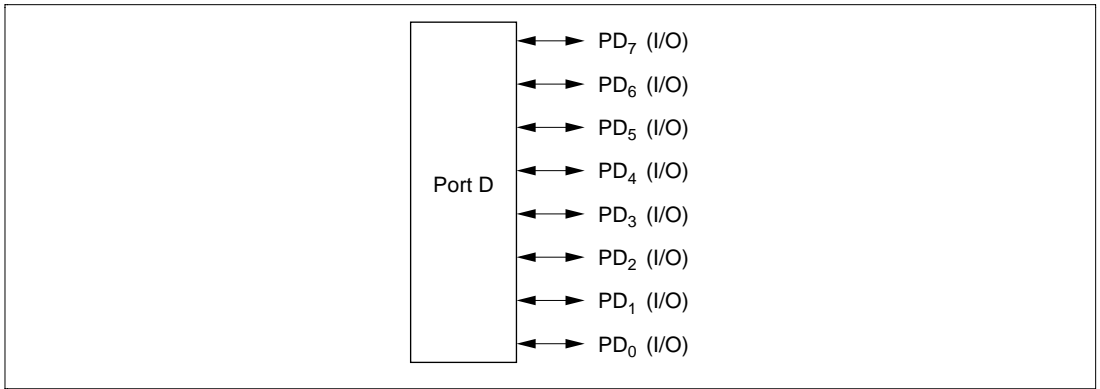

Figure 8-21 Port D Pin Functions (Modes 3 and 7)

8.11.4 MOS Input Pull-Up Function

Port D has a built-in MOS input pull-up function that can be controlled by software. This MOS input pull-up function can be used in modes 3 and 7, and can be specified as on or off on an individual bit basis.

When a PDDDR bit is cleared to 0 in mode 3 or 7, setting the corresponding PDPCR bit to 1 turns on the MOS input pull-up for that pin.

The MOS input pull-up function is in the off state after a power-on reset, and in hardware standby mode. The prior state is retained after a manual reset, and in software standby mode.

Table 8-20 summarizes the MOS input pull-up states.

Table 8-20 MOS Input Pull-Up States (Port D)

Modes	Power-On Reset	Hardware Standby Mode	Manual Reset	Software Standby Mode	In Other Operations
1, 2, 4 to 6	OFF		OFF		
3, 7			ON/OFF		

Legend:

OFF : MOS input pull-up is always off.

ON/OFF : On when PDDDR = 0 and PDPCR = 1; otherwise off.

8.12 Port E

8.12.1 Overview

Port E is an 8-bit I/O port. Port E has a data bus I/O function, and the pin functions change according to the operating mode and whether 8-bit or 16-bit bus mode is selected.

Port E has a built-in MOS input pull-up function that can be controlled by software.

Figure 8-22 shows the port E pin configuration.

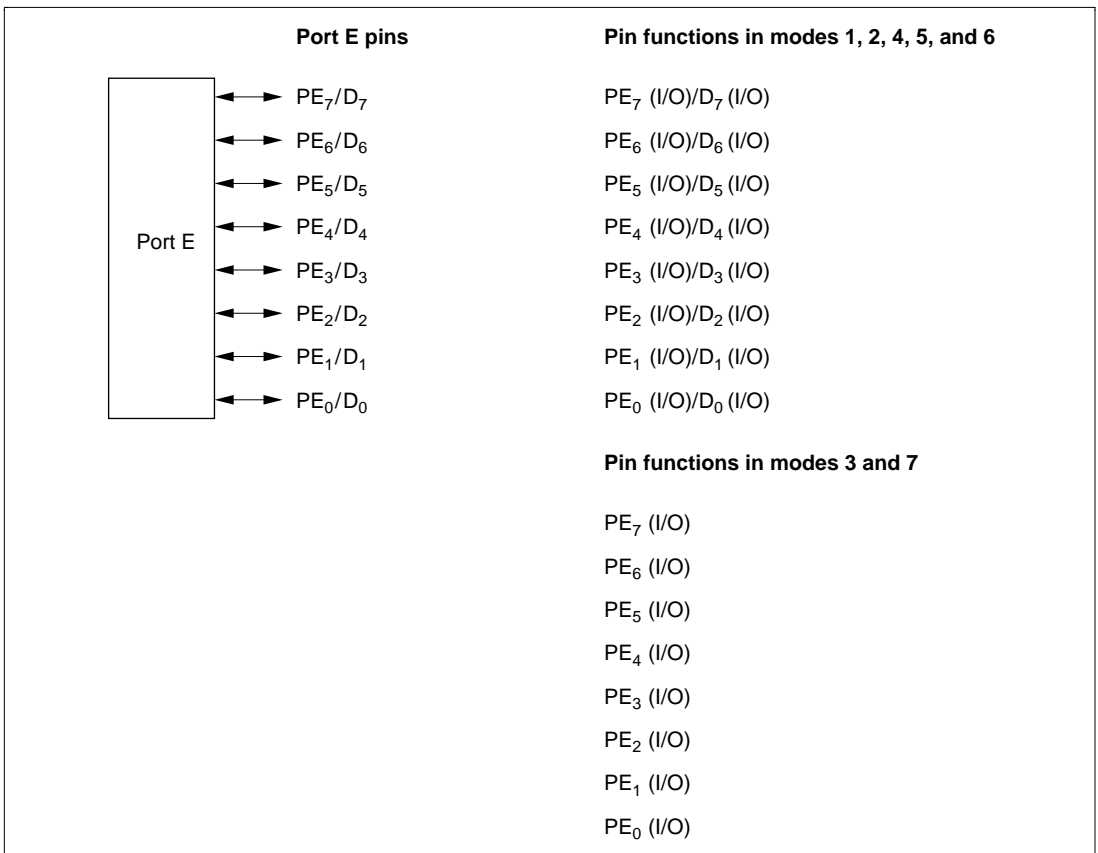

Figure 8-22 Port E Pin Functions

8.12.2 Register Configuration

Table 8-21 shows the port E register configuration.

Table 8-21 Port E Registers

Name	Abbreviation	R/W	Initial Value	Address *
Port E data direction register	PEDDDR	W	H'00	H'FEBD
Port E data register	PEDR	R/W	H'00	H'FF6D
Port E register	PORTE	R	Undefined	H'FF5D
Port E MOS pull-up control register	PEPCR	R/W	H'00	H'FF74

Note: * Lower 16 bits of the address.

Port E Data Direction Register (PEDDDR)

Bit	:	7	6	5	4	3	2	1	0
		PE7DDR	PE6DDR	PE5DDR	PE4DDR	PE3DDR	PE2DDR	PE1DDR	PE0DDR
Initial value	:	0	0	0	0	0	0	0	0
R/W	:	W	W	W	W	W	W	W	W

PEDDDR is an 8-bit write-only register, the individual bits of which specify input or output for the pins of port E. PEDDDR cannot be read; if it is, an undefined value will be read.

PEDDDR is initialized to H'00 by a power-on reset, and in hardware standby mode. It retains its prior state after a manual reset, and in software standby mode.

- Modes 1, 2, 4, 5, and 6

When 8-bit bus mode has been selected, port E pins function as I/O ports. Setting a PEDDDR bit to 1 makes the corresponding port E pin an output port, while clearing the bit to 0 makes the pin an input port.

When 16-bit bus mode has been selected, the input/output direction specification by PEDDDR is ignored, and port E is designated for data I/O.

For details of 8-bit and 16-bit bus modes, see section 6, Bus Controller.

- Modes 3 and 7

Setting a PEDDDR bit to 1 makes the corresponding port E pin an output port, while clearing the bit to 0 makes the pin an input port.

Port E Data Register (PEDR)

Bit	:	7	6	5	4	3	2	1	0
		PE7DR	PE6DR	PE5DR	PE4DR	PE3DR	PE2DR	PE1DR	PE0DR
Initial value	:	0	0	0	0	0	0	0	0
R/W	:	R/W	R/W	R/W	R/W	R/W	R/W	R/W	R/W

PEDR is an 8-bit readable/writable register that stores output data for the port E pins (PE₇ to PE₀).

PEDR is initialized to H'00 by a power-on reset, and in hardware standby mode. It retains its prior state after a manual reset, and in software standby mode.

Port E Register (PORTE)

Bit	:	7	6	5	4	3	2	1	0
		PE7	PE6	PE5	PE4	PE3	PE2	PE1	PE0
Initial value	:	—*	—*	—*	—*	—*	—*	—*	—*
R/W	:	R	R	R	R	R	R	R	R

Note: * Determined by state of pins PE₇ to PE₀.

PORTE is an 8-bit read-only register that shows the pin states. It cannot be written to. Writing of output data for the port E pins (PE₇ to PE₀) must always be performed on PEDR.

If a port E read is performed while PEDDR bits are set to 1, the PEDR values are read. If a port E read is performed while PEDDR bits are cleared to 0, the pin states are read.

After a power-on reset and in hardware standby mode, PORTE contents are determined by the pin states, as PEDDR and PEDR are initialized. PORTE retains its prior state after a manual reset, and in software standby mode.

Port E MOS Pull-Up Control Register (PEPCR)

Bit	:	7	6	5	4	3	2	1	0
		PE7PCR	PE6PCR	PE5PCR	PE4PCR	PE3PCR	PE2PCR	PE1PCR	PE0PCR
Initial value	:	0	0	0	0	0	0	0	0
R/W	:	R/W	R/W	R/W	R/W	R/W	R/W	R/W	R/W

PEPCR is an 8-bit readable/writable register that controls the MOS input pull-up function incorporated into port E on an individual bit basis.

When a PEDDR bit is cleared to 0 (input port setting) when 8-bit bus mode is selected in mode 1, 2, 4, 5, or 6, or in mode 3 or 7, setting the corresponding PEPCR bit to 1 turns on the MOS input pull-up for the corresponding pin.

PEPCR is initialized to H'00 by a power-on reset, and in hardware standby mode. It retains its prior state after a manual reset, and in software standby mode.

8.12.3 Pin Functions

Modes 1, 2, 4, 5, and 6: In modes 1, 2, 4, 5, and 6, when 8-bit access is designated and 8-bit bus mode is selected, port E pins are automatically designated as I/O ports. Setting a PEDDR bit to 1 makes the corresponding port E pin an output port, while clearing the bit to 0 makes the pin an input port.

When 16-bit bus mode is selected, the input/output direction specification by PEDDR is ignored, and port E is designated for data I/O.

Port E pin functions in modes 1, 2, 4, 5, and 6 are shown in figure 8-23.

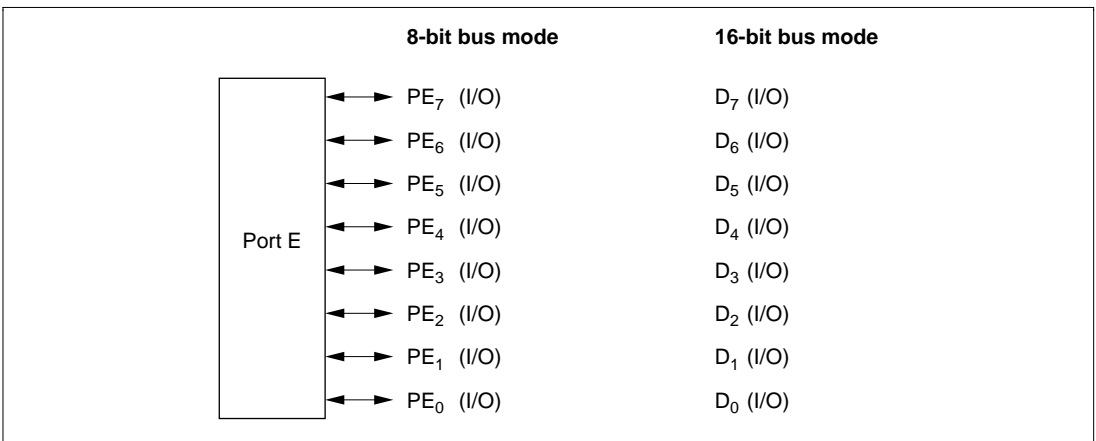

Figure 8-23 Port E Pin Functions (Modes 1, 2, 4, 5, and 6)

Modes 3 and 7: In modes 3 and 7, port E pins function as I/O ports. Input or output can be specified for each pin on a bit-by-bit basis. Setting a PEDDR bit to 1 makes the corresponding port E pin an output port, while clearing the bit to 0 makes the pin an input port.

Port E pin functions in modes 3 and 7 are shown in figure 8-24.

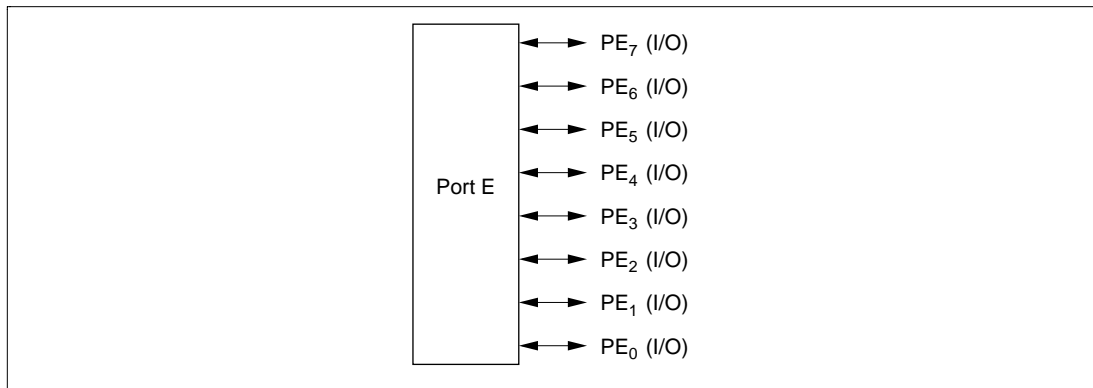

Figure 8-24 Port E Pin Functions (Modes 3 and 7)

8.12.4 MOS Input Pull-Up Function

Port E has a built-in MOS input pull-up function that can be controlled by software. This MOS input pull-up function can be used in modes 1, 2, 4, 5, and 6 when 8-bit bus mode is selected, or in mode 3 or 7, and can be specified as on or off on an individual bit basis.

When a PEDDR bit is cleared to 0 in mode 1, 2, 4, 5, or 6 when 8-bit bus mode is selected, or in mode 3 or 7, setting the corresponding PEPCR bit to 1 turns on the MOS input pull-up for that pin.

The MOS input pull-up function is in the off state after a power-on reset, and in hardware standby mode. The prior state is retained after a manual reset, and in software standby mode.

Table 8-22 summarizes the MOS input pull-up states.

Table 8-22 MOS Input Pull-Up States (Port E)

Modes	Power-On Reset	Hardware Standby Mode	Manual Reset	Software Standby Mode	In Other Operations
3, 7	OFF		ON/OFF		
1, 2, 4 to 6	8-bit bus				
	16-bit bus		OFF		

Legend:

OFF : MOS input pull-up is always off.

ON/OFF : On when PEDDR = 0 and PEPCR = 1; otherwise off.

8.13 Port F

8.13.1 Overview

Port F is an 8-bit I/O port. Port F pins also function as bus control signal input/output pins (\overline{AS} , \overline{RD} , \overline{HWR} , \overline{LWR} , \overline{WAIT} , \overline{BREQ} , and \overline{BACK}) and the system clock (\emptyset) output pin.

Figure 8-25 shows the port F pin configuration.

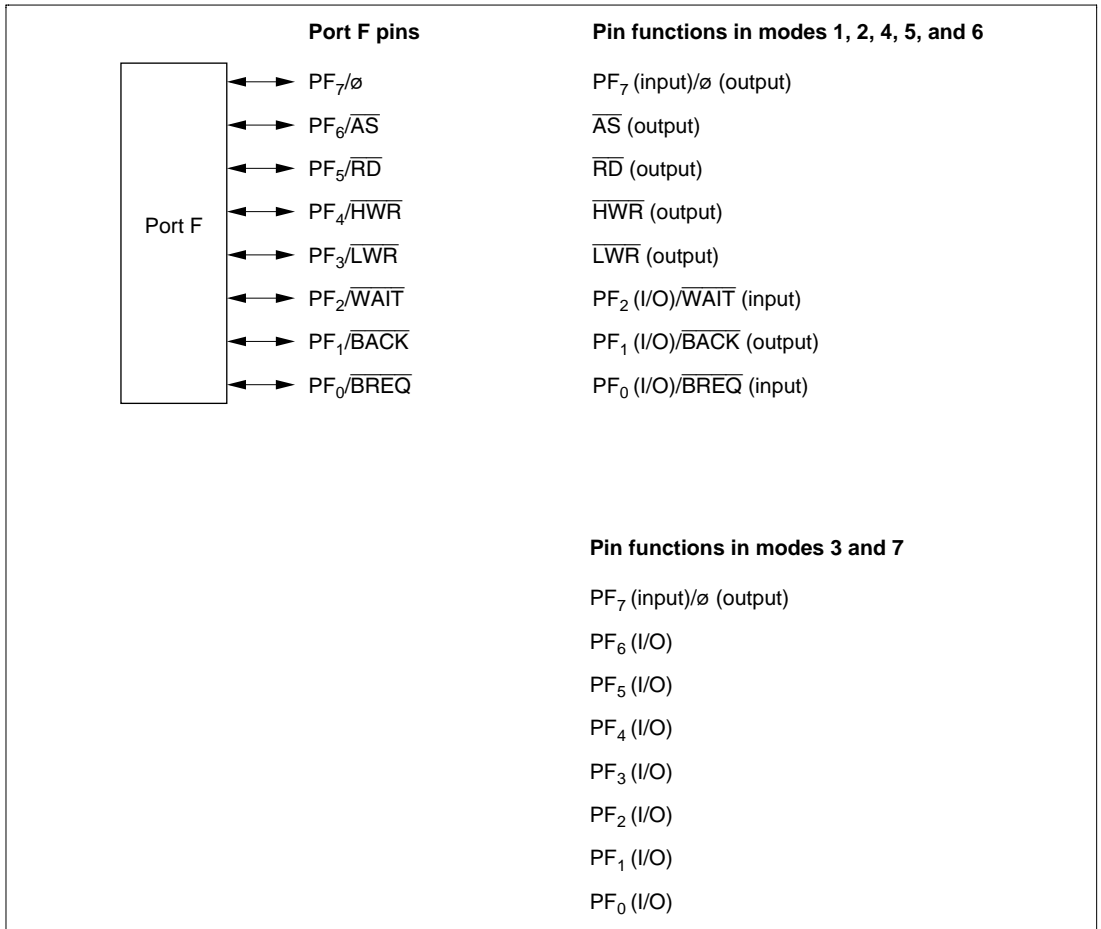

Figure 8-25 Port F Pin Functions

8.13.2 Register Configuration

Table 8-23 shows the port F register configuration.

Table 8-23 Port F Registers

Name	Abbreviation	R/W	Initial Value	Address ^{*1}
Port F data direction register	PFDDR	W	H'80/H'00 ^{*2}	H'FEBE
Port F data register	PFDR	R/W	H'00	H'FF6E
Port F register	PORTF	R	Undefined	H'FF5E

Notes: 1. Lower 16 bits of the address.
2. Initial value depends on the mode.

Port F Data Direction Register (PFDDR)

Bit	:	7	6	5	4	3	2	1	0
		PF7DDR	PF6DDR	PF5DDR	PF4DDR	PF3DDR	PF2DDR	PF1DDR	PF0DDR
Modes 1, 2, 4, 5, 6									
Initial value :		1	0	0	0	0	0	0	0
R/W :		W	W	W	W	W	W	W	W
Modes 3 and 7									
Initial value :		0	0	0	0	0	0	0	0
R/W :		W	W	W	W	W	W	W	W

PFDDR is an 8-bit write-only register, the individual bits of which specify input or output for the pins of port F. PFDDR cannot be read; if it is, an undefined value will be read.

PFDDR is initialized by a power-on reset, and in hardware standby mode, to H'80 in modes 1, 2, 4, 5, and 6, and to H'00 in modes 3 and 7. It retains its prior state after a manual reset, and in software standby mode. The OPE bit in SBYCR is used to select whether the bus control output pins retain their output state or become high-impedance when a transition is made to software standby mode.

- Modes 1, 2, 4, 5, and 6

Pin PF₇ functions as the \emptyset output pin when the corresponding PFDDR bit is set to 1, and as an input port when the bit is cleared to 0.

The input/output direction specified by PFDDR is ignored for pins PF₆ to PF₃, which are automatically designated as bus control outputs (\overline{AS} , \overline{RD} , \overline{HWR} , and \overline{LWR}).

Pins PF₂ to PF₀ are designated as bus control input/output pins (\overline{WAIT} , \overline{BACK} , \overline{BREQ}) by means of bus controller settings. At other times, setting a PFDDR bit to 1 makes the corresponding port F pin an output port, while clearing the bit to 0 makes the pin an input port.

- Modes 3 and 7

Setting a PFDDR bit to 1 makes the corresponding port F pin PF₆ to PF₀ an output port, or in the case of pin PF₇, the \emptyset output pin. Clearing the bit to 0 makes the pin an input port.

Port F Data Register (PFDR)

Bit	:	7	6	5	4	3	2	1	0
		PF7DR	PF6DR	PF5DR	PF4DR	PF3DR	PF2DR	PF1DR	PF0DR
Initial value	:	0	0	0	0	0	0	0	0
R/W	:	R/W	R/W	R/W	R/W	R/W	R/W	R/W	R/W

PFDR is an 8-bit readable/writable register that stores output data for the port F pins (PF₇ to PF₀).

PFDR is initialized to H'00 by a power-on reset, and in hardware standby mode. It retains its prior state after a manual reset, and in software standby mode.

Port F Register (PORTF)

Bit	:	7	6	5	4	3	2	1	0
		PF7	PF6	PF5	PF4	PF3	PF2	PF1	PF0
Initial value	:	—*	—*	—*	—*	—*	—*	—*	—*
R/W	:	R	R	R	R	R	R	R	R

Note: * Determined by state of pins PF₇ to PF₀.

PORTF is an 8-bit read-only register that shows the pin states. Writing of output data for the port F pins (PF₇ to PF₀) must always be performed on PFDR.

If a port F read is performed while PFDDR bits are set to 1, the PFDR values are read. If a port F read is performed while PFDDR bits are cleared to 0, the pin states are read.

After a power-on reset and in hardware standby mode, PORTF contents are determined by the pin states, as PFDDR and PFDR are initialized. PORTF retains its prior state after a manual reset, and in software standby mode.

8.13.3 Pin Functions

Port F pins also function as bus control signal input/output pins (\overline{AS} , \overline{RD} , \overline{HWR} , \overline{LWR} , \overline{WAIT} , \overline{BREQ} , and \overline{BACK}) and the system clock (\emptyset) output pin. The pin functions differ between modes 1, 2, 4, 5, and 6, and modes 3 and 7. Port F pin functions are shown in table 8-24.

Table 8-24 Port F Pin Functions

Pin	Selection Method and Pin Functions		
PF ₇ / \emptyset	The pin function is switched as shown below according to bit PF7DDR.		
	PF7DDR	0	1
	Pin function	PF ₇ input pin	\emptyset output pin

PF ₆ / \overline{AS}	The pin function is switched as shown below according to the operating mode and bit PF6DDR.			
	Operating Mode	Modes 1, 2, 4, 5, 6	Modes 3 and 7	
	PF6DDR	—	0	1
	Pin function	\overline{AS} output pin	PF ₆ input pin	PF ₆ output pin

PF ₅ / \overline{RD}	The pin function is switched as shown below according to the operating mode and bit PF5DDR.			
	Operating Mode	Modes 1, 2, 4, 5, 6	Modes 3 and 7	
	PF5DDR	—	0	1
	Pin function	\overline{RD} output pin	PF ₅ input pin	PF ₅ output pin

PF ₄ / \overline{HWR}	The pin function is switched as shown below according to the operating mode and bit PF4DDR.			
	Operating Mode	Modes 1, 2, 4, 5, 6	Modes 3 and 7	
	PF4DDR	—	0	1
	Pin function	\overline{HWR} output pin	PF ₄ input pin	PF ₄ output pin

Pin**Selection Method and Pin Functions** PF_3/\overline{LWR}

The pin function is switched as shown below according to the operating mode and bit PF3DDR.

Operating Mode	Modes 1, 2, 4, 5, 6		Modes 3 and 7	
PF3DDR	—		0	1
Pin function	\overline{LWR} output pin		PF ₃ input pin	PF ₃ output pin

 PF_2/\overline{WAIT}

The pin function is switched as shown below according to the combination of the operating mode, and bits WAITE and PF2DDR.

Operating Mode	Modes 1, 2, 4, 5, 6			Modes 3 and 7	
WAITE	0			1	—
PF2DDR	0	1	—	0	1
Pin function	PF ₂ input pin	PF ₂ output pin	\overline{WAIT} input pin	PF ₂ input pin	PF ₂ output pin

Note: *Only when RMTS2 to RMTS0 = B'001 to B'011 and CW2 = 0 in modes 4 to 6.

 PF_1/\overline{BACK}

The pin function is switched as shown below according to the combination of the operating mode, and bits BRLE and PF1DDR.

Operating Mode	Modes 1, 2, 4, 5, 6			Modes 3 and 7	
BRLE	0			1	—
PF1DDR	0	1	—	0	1
Pin function	PF ₁ input pin	PF ₁ output pin	\overline{BACK} output pin	PF ₁ input pin	PF ₁ output pin

 PF_0/\overline{BREQ}

The pin function is switched as shown below according to the combination of the operating mode, and bits BRLE and PF0DDR.

Operating Mode	Modes 1, 2, 4, 5, 6			Modes 3 and 7	
BRLE	0			1	—
PF0DDR	0	1	—	0	1
Pin function	PF ₀ input pin	PF ₀ output pin	\overline{BREQ} input pin	PF ₀ input pin	PF ₀ output pin

8.14 Port G

8.14.1 Overview

Port G is a 5-bit I/O port. Port G pins also function as bus control signal output pins ($\overline{CS0}$ to $\overline{CS3}$, \overline{CAS} , and \overline{OE}).

Figure 8-26 shows the port G pin configuration.

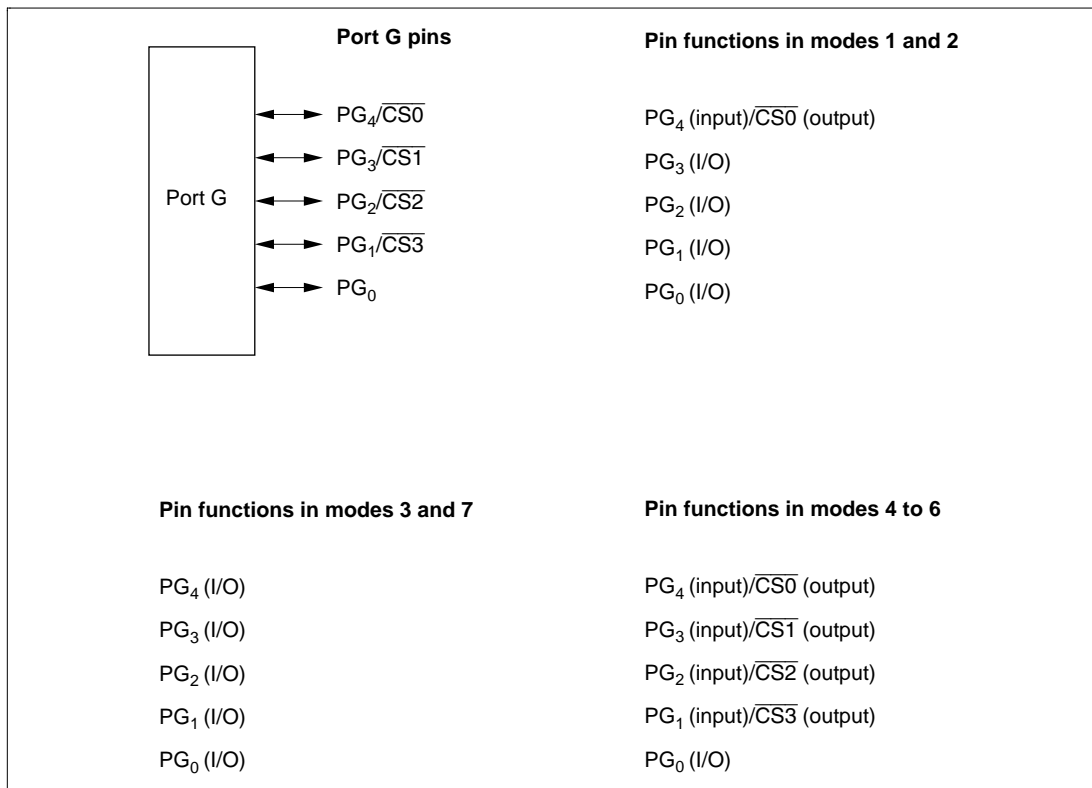

Figure 8-26 Port G Pin Functions

8.14.2 Register Configuration

Table 8-25 shows the port G register configuration.

Table 8-25 Port G Registers

Name	Abbreviation	R/W	Initial Value * ²	Address * ¹
Port G data direction register	PGDDR	W	H'10/H'00* ³	H'FEBF
Port G data register	PGDR	R/W	H'00	H'FF6F
Port G register	PORTG	R	Undefined	H'FF5F

Notes: 1. Lower 16 bits of the address.
 2. Value of bits 4 to 0.
 3. Initial value depends on the mode.

Port G Data Direction Register (PGDDR)

Bit	:	7	6	5	4	3	2	1	0
		—	—	—	PG4DDR	PG3DDR	PG2DDR	PG1DDR	PG0DDR

Modes 1, 4, 5

Initial value : Undefined Undefined Undefined 1 0 0 0 0

R/W : — — — W W W W W

Modes 2, 3, 6, 7

Initial value : Undefined Undefined Undefined 0 0 0 0 0

R/W : — — — W W W W W

PGDDR is an 8-bit write-only register, the individual bits of which specify input or output for the pins of port G. PGDDR cannot be read, and bits 7 to 5 are reserved. If PGDDR is read, an undefined value will be read.

The PGDDR4 bit is initialized by a power-on reset and in hardware standby mode, to 1 in modes 1, 4, and 5, and to 0 in modes 2, 3, 6, and 7. It retains its prior state after a manual reset and in software standby mode. The OPE bit in SBYCR is used to select whether the bus control output pins retain their output state or become high-impedance when a transition is made to software standby mode.

- Modes 1 and 2

Pin PG₄ functions as a bus control output pin ($\overline{CS0}$) when the corresponding PGDDR bit is set to 1, and as an input port when the bit is cleared to 0.

For pins PG₃ to PG₀, setting the corresponding PGDDR bit to 1 makes the pin an output port, while clearing the bit to 0 makes the pin an input port.

- Modes 3 and 7

Setting a PGDDR bit to 1 makes the corresponding port G pin an output port, while clearing the bit to 0 makes the pin an input port.

- Modes 4, 5, and 6

Pins PG₄ to PG₁ function as bus control output pins ($\overline{CS0}$ to $\overline{CS3}$) when the corresponding PGDDR bits are set to 1, and as input ports when the bits are cleared to 0.

Port G Data Register (PGDR)

Bit	:	7	6	5	4	3	2	1	0
		—	—	—	PG4DR	PG3DR	PG2DR	PG1DR	PG0DR
Initial value	:	Undefined	Undefined	Undefined	0	0	0	0	0
R/W	:	—	—	—	R/W	R/W	R/W	R/W	R/W

PGDR is an 8-bit readable/writable register that stores output data for the port G pins (PG₄ to PG₀).

Bits 7 to 5 are reserved; they return an undetermined value if read, and cannot be modified.

PGDR is initialized to H'00 (bits 4 to 0) by a power-on reset, and in hardware standby mode. It retains its prior state after a manual reset, and in software standby mode.

Port G Register (PORTG)

Bit	:	7	6	5	4	3	2	1	0
		—	—	—	PG4	PG3	PG2	PG1	PG0
Initial value	:	Undefined	Undefined	Undefined	—*	—*	—*	—*	—*
R/W	:	—	—	—	R	R	R	R	R

Note: * Determined by state of pins PG₄ to PG₀.

PORTG is an 8-bit read-only register that shows the pin states. It cannot be written to. Writing of output data for the port G pins (PG₄ to PG₀) must always be performed on PGDR.

Bits 7 to 5 are reserved; they return an undetermined value if read, and cannot be modified.

If a port G read is performed while PGDDR bits are set to 1, the PGDR values are read. If a port G read is performed while PGDDR bits are cleared to 0, the pin states are read.

After a power-on reset and in hardware standby mode, PORTG contents are determined by the pin states, as PGDDR and PGDR are initialized. PORTG retains its prior state after a manual reset, and in software standby mode.

8.14.3 Pin Functions

Port G pins also function as bus control signal output pins ($\overline{CS0}$ to $\overline{CS3}$, \overline{CAS} , and \overline{OE}). The pin functions are different in modes 1 and 2, modes 3 and 7, and modes 4 to 6. Port G pin functions are shown in table 8-26.

Table 8-26 Port G Pin Functions

Pin Selection Method and Pin Functions

$PG_4/\overline{CS0}$

The pin function is switched as shown below according to the operating mode and bit PG4DDR.

Operating Mode	Modes 1, 2, 4, 5, 6		Modes 3 and 7	
PG4DDR	0	1	0	1
Pin function	PG_4 input pin	$\overline{CS0}$ output pin	PG_4 input pin	PG_4 output pin

$PG_3/\overline{CS1}$

The pin function is switched as shown below according to the operating mode and bit PG3DDR.

Operating Mode	Modes 1, 2, 3, 7		Modes 4 to 6	
PG3DDR	0	1	0	1
Pin function	PG_3 input pin	PG_3 output pin	PG_3 input pin	$\overline{CS1}$ output pin

$PG_2/\overline{CS2}$

The pin function is switched as shown below according to the operating mode and bit PG2DDR.

Operating Mode	Modes 1, 2, 3, 7		Modes 4 to 6	
PG2DDR	0	1	0	1
Pin function	PG_2 input pin	PG_2 output pin	PG_2 input pin	$\overline{CS2}$ output pin

Pin**Selection Method and Pin Functions** $PG_1/\overline{CS3}$

The pin function is switched as shown below according to the operating mode and bit PG1DDR.

Operating Mode	Modes 1, 2, 3, 7		Modes 4 to 6	
	PG1DDR	0	1	0
Pin function	PG_1 input pin	PG_1 output pin	PG_1 input pin	$\overline{CS3}$ output pin

 PG_0

The pin function is switched as shown below according to the bit PG0DDR.

PG0DDR	0	1
Pin function	PG_0 input pin	PG_0 output pin

Section 9 16-Bit Timer Pulse Unit (TPU)

9.1 Overview

The H8S/2355 Series has an on-chip 16-bit timer pulse unit (TPU) that comprises six 16-bit timer channels.

9.1.1 Features

- Maximum 16-pulse input/output
 - A total of 16 timer general registers (TGRs) are provided (four each for channels 0 and 3, and two each for channels 1, 2, 4, and 5), each of which can be set independently as an output compare/input capture register
 - TGRC and TGRD for channels 0 and 3 can also be used as buffer registers
- Selection of 8 counter input clocks for each channel
- The following operations can be set for each channel:
 - Waveform output at compare match: Selection of 0, 1, or toggle output
 - Input capture function: Selection of rising edge, falling edge, or both edge detection
 - Counter clear operation: Counter clearing possible by compare match or input capture
 - Synchronous operation: Multiple timer counters (TCNT) can be written to simultaneously
 - Simultaneous clearing by compare match and input capture possible
 - Register simultaneous input/output possible by counter synchronous operation
 - PWM mode: Any PWM output duty can be set
 - Maximum of 15-phase PWM output possible by combination with synchronous operation
- Buffer operation settable for channels 0 and 3
 - Input capture register double-buffering possible
 - Automatic rewriting of output compare register possible
- Phase counting mode settable independently for each of channels 1, 2, 4, and 5
 - Two-phase encoder pulse up/down-count possible
- Cascaded operation
 - Channel 2 (channel 5) input clock operates as 32-bit counter by setting channel 1 (channel 4) overflow/underflow
- Fast access via internal 16-bit bus
 - Fast access is possible via a 16-bit bus interface

- 26 interrupt sources
 - For channels 0 and 3, four compare match/input capture dual-function interrupts and one overflow interrupt can be requested independently
 - For channels 1, 2, 4, and 5, two compare match/input capture dual-function interrupts, one overflow interrupt, and one underflow interrupt can be requested independently
- Automatic transfer of register data
 - Block transfer, 1-word data transfer, and 1-byte data transfer possible by data transfer controller (DTC) activation
- A/D converter conversion start trigger can be generated
 - Channel 0 to 5 compare match A/input capture A signals can be used as A/D converter conversion start trigger
- Module stop mode can be set
 - As the initial setting, TPU operation is halted. Register access is enabled by exiting module stop mode.

Table 9-1 lists the functions of the TPU.

Table 9-1 TPU Functions

Item	Channel 0	Channel 1	Channel 2	Channel 3	Channel 4	Channel 5
Count clock	$\emptyset/1$	$\emptyset/1$	$\emptyset/1$	$\emptyset/1$	$\emptyset/1$	$\emptyset/1$
	$\emptyset/4$	$\emptyset/4$	$\emptyset/4$	$\emptyset/4$	$\emptyset/4$	$\emptyset/4$
	$\emptyset/16$	$\emptyset/16$	$\emptyset/16$	$\emptyset/16$	$\emptyset/16$	$\emptyset/16$
	$\emptyset/64$	$\emptyset/64$	$\emptyset/64$	$\emptyset/64$	$\emptyset/64$	$\emptyset/64$
	TCLKA	$\emptyset/256$	$\emptyset/1024$	$\emptyset/256$	$\emptyset/1024$	$\emptyset/256$
	TCLKB	TCLKA	TCLKA	$\emptyset/1024$	TCLKA	TCLKA
	TCLKC	TCLKB	TCLKB	$\emptyset/4096$	TCLKC	TCLKC
	TCLKD	TCLKC	TCLKC	TCLKA		TCLKD
General registers	TGR0A	TGR1A	TGR2A	TGR3A	TGR4A	TGR5A
	TGR0B	TGR1B	TGR2B	TGR3B	TGR4B	TGR5B
General registers/ buffer registers	TGR0C	—	—	TGR3C	—	—
	TGR0D			TGR3D		
I/O pins	TIOCA0	TIOCA1	TIOCA2	TIOCA3	TIOCA4	TIOCA5
	TIOCB0	TIOCB1	TIOCB2	TIOCB3	TIOCB4	TIOCB5
	TIOCC0			TIOCC3		
	TIOCD0			TIOCD3		
Counter clear function	TGR compare match or input capture	TGR compare match or input capture	TGR compare match or input capture	TGR compare match or input capture	TGR compare match or input capture	TGR compare match or input capture
Compare match output	0 output	<input type="radio"/>	<input type="radio"/>	<input type="radio"/>	<input type="radio"/>	<input type="radio"/>
	1 output	<input type="radio"/>	<input type="radio"/>	<input type="radio"/>	<input type="radio"/>	<input type="radio"/>
	Toggle output	<input type="radio"/>	<input type="radio"/>	<input type="radio"/>	<input type="radio"/>	<input type="radio"/>
Input capture function	<input type="radio"/>	<input type="radio"/>	<input type="radio"/>	<input type="radio"/>	<input type="radio"/>	<input type="radio"/>
Synchronous operation	<input type="radio"/>	<input type="radio"/>	<input type="radio"/>	<input type="radio"/>	<input type="radio"/>	<input type="radio"/>
PWM mode	<input type="radio"/>	<input type="radio"/>	<input type="radio"/>	<input type="radio"/>	<input type="radio"/>	<input type="radio"/>
Phase counting mode	—	<input type="radio"/>	<input type="radio"/>	—	<input type="radio"/>	<input type="radio"/>
Buffer operation	<input type="radio"/>	—	—	<input type="radio"/>	—	—

Item	Channel 0	Channel 1	Channel 2	Channel 3	Channel 4	Channel 5
DTC activation	TGR compare match or input capture	TGR compare match or input capture	TGR compare match or input capture	TGR compare match or input capture	TGR compare match or input capture	TGR compare match or input capture
A/D converter trigger	TGR0A compare match or input capture	TGR1A compare match or input capture	TGR2A compare match or input capture	TGR3A compare match or input capture	TGR4A compare match or input capture	TGR5A compare match or input capture
Interrupt sources	5 sources <ul style="list-style-type: none"> • Compare match or input capture 0A • Compare match or input capture 0B • Compare match or input capture 0C • Compare match or input capture 0D • Overflow 	4 sources <ul style="list-style-type: none"> • Compare match or input capture 1A • Compare match or input capture 1B • Overflow • Underflow 	4 sources <ul style="list-style-type: none"> • Compare match or input capture 2A • Compare match or input capture 2B • Overflow • Underflow 	5 sources <ul style="list-style-type: none"> • Compare match or input capture 3A • Compare match or input capture 3B • Compare match or input capture 3C • Compare match or input capture 3D • Overflow 	4 sources <ul style="list-style-type: none"> • Compare match or input capture 4A • Compare match or input capture 4B • Overflow • Underflow 	4 sources <ul style="list-style-type: none"> • Compare match or input capture 5A • Compare match or input capture 5B • Overflow • Underflow

Legend

○ : Possible

— : Not possible

9.1.2 Block Diagram

Figure 9-1 shows a block diagram of the TPU.

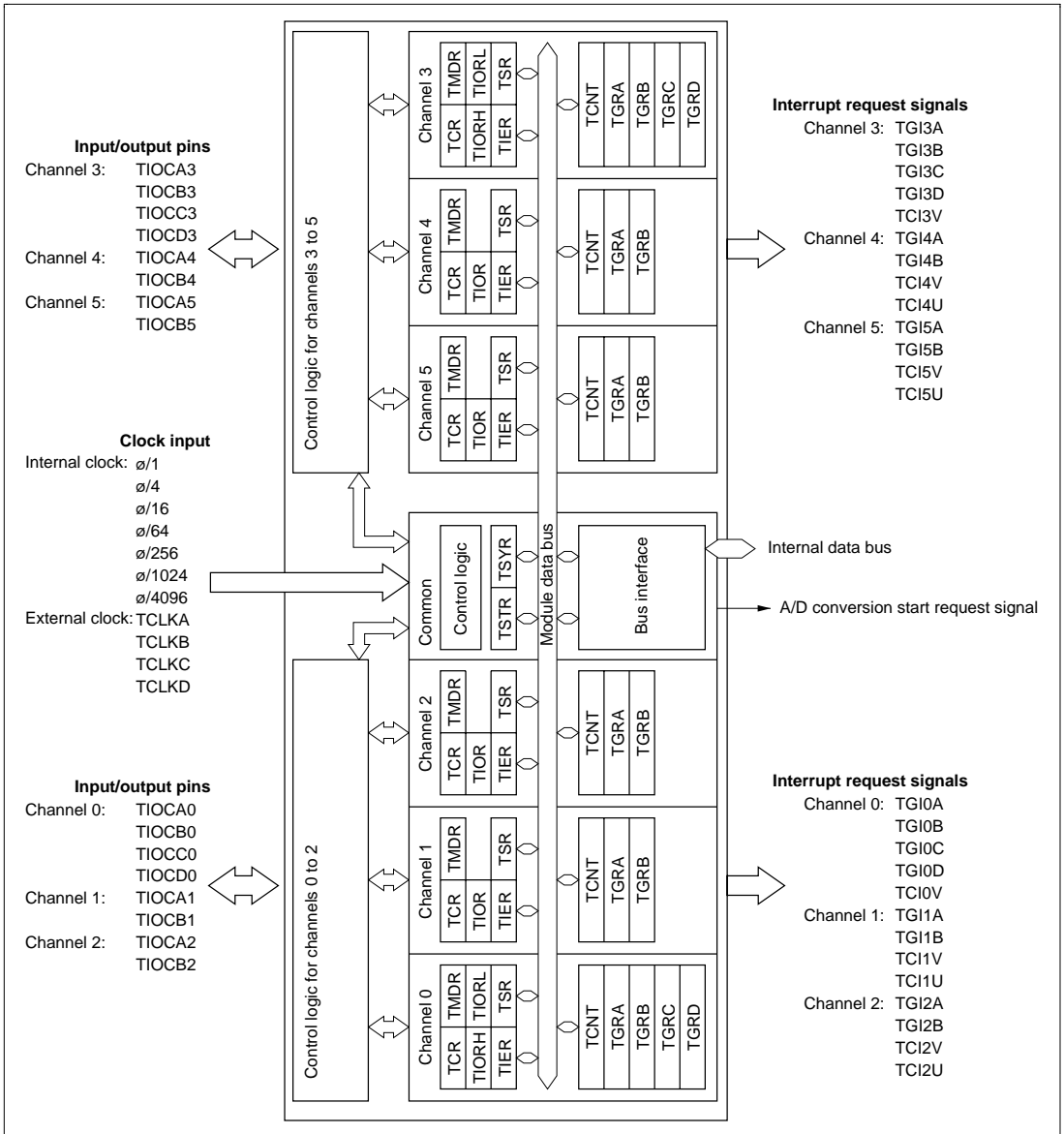

Figure 9-1 Block Diagram of TPU

9.1.3 Pin Configuration

Table 9-2 summarizes the TPU pins.

Table 9-2 TPU Pins

Channel	Name	Symbol	I/O	Function
All	Clock input A	TCLKA	Input	External clock A input pin (Channel 1 and 5 phase counting mode A phase input)
	Clock input B	TCLKB	Input	External clock B input pin (Channel 1 and 5 phase counting mode B phase input)
	Clock input C	TCLKC	Input	External clock C input pin (Channel 2 and 4 phase counting mode A phase input)
	Clock input D	TCLKD	Input	External clock D input pin (Channel 2 and 4 phase counting mode B phase input)
0	Input capture/out compare match A0	TIOCA0	I/O	TGR0A input capture input/output compare output/PWM output pin
	Input capture/out compare match B0	TIOCB0	I/O	TGR0B input capture input/output compare output/PWM output pin
	Input capture/out compare match C0	TIOCC0	I/O	TGR0C input capture input/output compare output/PWM output pin
	Input capture/out compare match D0	TIOCD0	I/O	TGR0D input capture input/output compare output/PWM output pin
1	Input capture/out compare match A1	TIOCA1	I/O	TGR1A input capture input/output compare output/PWM output pin
	Input capture/out compare match B1	TIOCB1	I/O	TGR1B input capture input/output compare output/PWM output pin
2	Input capture/out compare match A2	TIOCA2	I/O	TGR2A input capture input/output compare output/PWM output pin
	Input capture/out compare match B2	TIOCB2	I/O	TGR2B input capture input/output compare output/PWM output pin

Channel	Name	Symbol	I/O	Function
3	Input capture/out compare match A3	TIOCA3	I/O	TGR3A input capture input/output compare output/PWM output pin
	Input capture/out compare match B3	TIOCB3	I/O	TGR3B input capture input/output compare output/PWM output pin
	Input capture/out compare match C3	TIOCC3	I/O	TGR3C input capture input/output compare output/PWM output pin
	Input capture/out compare match D3	TIOCD3	I/O	TGR3D input capture input/output compare output/PWM output pin
4	Input capture/out compare match A4	TIOCA4	I/O	TGR4A input capture input/output compare output/PWM output pin
	Input capture/out compare match B4	TIOCB4	I/O	TGR4B input capture input/output compare output/PWM output pin
5	Input capture/out compare match A5	TIOCA5	I/O	TGR5A input capture input/output compare output/PWM output pin
	Input capture/out compare match B5	TIOCB5	I/O	TGR5B input capture input/output compare output/PWM output pin

9.1.4 Register Configuration

Table 9-3 summarizes the TPU registers.

Table 9-3 TPU Registers

Channel	Name	Abbreviation	R/W	Initial Value	Address ^{*1}
0	Timer control register 0	TCR0	R/W	H'00	H'FFD0
	Timer mode register 0	TMDR0	R/W	H'C0	H'FFD1
	Timer I/O control register 0H	TIOR0H	R/W	H'00	H'FFD2
	Timer I/O control register 0L	TIOR0L	R/W	H'00	H'FFD3
	Timer interrupt enable register 0	TIER0	R/W	H'40	H'FFD4
	Timer status register 0	TSR0	R/(W) ^{*2}	H'C0	H'FFD5
	Timer counter 0	TCNT0	R/W	H'0000	H'FFD6
	Timer general register 0A	TGR0A	R/W	H'FFFF	H'FFD8
	Timer general register 0B	TGR0B	R/W	H'FFFF	H'FFDA
	Timer general register 0C	TGR0C	R/W	H'FFFF	H'FFDC
	Timer general register 0D	TGR0D	R/W	H'FFFF	H'FFDE
1	Timer control register 1	TCR1	R/W	H'00	H'FFE0
	Timer mode register 1	TMDR1	R/W	H'C0	H'FFE1
	Timer I/O control register 1	TIOR1	R/W	H'00	H'FFE2
	Timer interrupt enable register 1	TIER1	R/W	H'40	H'FFE4
	Timer status register 1	TSR1	R/(W) ^{*2}	H'C0	H'FFE5
	Timer counter 1	TCNT1	R/W	H'0000	H'FFE6
	Timer general register 1A	TGR1A	R/W	H'FFFF	H'FFE8
	Timer general register 1B	TGR1B	R/W	H'FFFF	H'FFEA
2	Timer control register 2	TCR2	R/W	H'00	H'FFF0
	Timer mode register 2	TMDR2	R/W	H'C0	H'FFF1
	Timer I/O control register 2	TIOR2	R/W	H'00	H'FFF2
	Timer interrupt enable register 2	TIER2	R/W	H'40	H'FFF4
	Timer status register 2	TSR2	R/(W) ^{*2}	H'C0	H'FFF5
	Timer counter 2	TCNT2	R/W	H'0000	H'FFF6
	Timer general register 2A	TGR2A	R/W	H'FFFF	H'FFF8
	Timer general register 2B	TGR2B	R/W	H'FFFF	H'FFFA

Channel	Name	Abbreviation	R/W	Initial Value	Address* ¹
3	Timer control register 3	TCR3	R/W	H'00	H'FE80
	Timer mode register 3	TMDR3	R/W	H'C0	H'FE81
	Timer I/O control register 3H	TIOR3H	R/W	H'00	H'FE82
	Timer I/O control register 3L	TIOR3L	R/W	H'00	H'FE83
	Timer interrupt enable register 3	TIER3	R/W	H'40	H'FE84
	Timer status register 3	TSR3	R/(W)* ²	H'C0	H'FE85
	Timer counter 3	TCNT3	R/W	H'0000	H'FE86
	Timer general register 3A	TGR3A	R/W	H'FFFF	H'FE88
	Timer general register 3B	TGR3B	R/W	H'FFFF	H'FE8A
	Timer general register 3C	TGR3C	R/W	H'FFFF	H'FE8C
	Timer general register 3D	TGR3D	R/W	H'FFFF	H'FE8E
4	Timer control register 4	TCR4	R/W	H'00	H'FE90
	Timer mode register 4	TMDR4	R/W	H'C0	H'FE91
	Timer I/O control register 4	TIOR4	R/W	H'00	H'FE92
	Timer interrupt enable register 4	TIER4	R/W	H'40	H'FE94
	Timer status register 4	TSR4	R/(W)* ²	H'C0	H'FE95
	Timer counter 4	TCNT4	R/W	H'0000	H'FE96
	Timer general register 4A	TGR4A	R/W	H'FFFF	H'FE98
	Timer general register 4B	TGR4B	R/W	H'FFFF	H'FE9A
5	Timer control register 5	TCR5	R/W	H'00	H'FEA0
	Timer mode register 5	TMDR5	R/W	H'C0	H'FEA1
	Timer I/O control register 5	TIOR5	R/W	H'00	H'FEA2
	Timer interrupt enable register 5	TIER5	R/W	H'40	H'FEA4
	Timer status register 5	TSR5	R/(W)* ²	H'C0	H'FEA5
	Timer counter 5	TCNT5	R/W	H'0000	H'FEA6
	Timer general register 5A	TGR5A	R/W	H'FFFF	H'FEA8
	Timer general register 5B	TGR5B	R/W	H'FFFF	H'FEAA
All	Timer start register	TSTR	R/W	H'00	H'FFC0
	Timer synchro register	TSYR	R/W	H'00	H'FFC1
	Module stop control register	MSTPCR	R/W	H'3FFF	H'FF3C

- Notes: 1. Lower 16 bits of the address.
2. Can only be written with 0 for flag clearing.

9.2 Register Descriptions

9.2.1 Timer Control Register (TCR)

Channel 0: TCR0

Channel 3: TCR3

Bit	:	7	6	5	4	3	2	1	0
		CCLR2	CCLR1	CCLR0	CKEG1	CKEG0	TPSC2	TPSC1	TPSC0
Initial value	:	0	0	0	0	0	0	0	0
R/W	:	R/W	R/W	R/W	R/W	R/W	R/W	R/W	R/W

Channel 1: TCR1

Channel 2: TCR2

Channel 4: TCR4

Channel 5: TCR5

Bit	:	7	6	5	4	3	2	1	0
		—	CCLR1	CCLR0	CKEG1	CKEG0	TPSC2	TPSC1	TPSC0
Initial value	:	0	0	0	0	0	0	0	0
R/W	:	—	R/W	R/W	R/W	R/W	R/W	R/W	R/W

The TCR registers are 8-bit registers that control the TCNT channels. The TPU has six TCR registers, one for each of channels 0 to 5. The TCR registers are initialized to H'00 by a reset, and in hardware standby mode.

TCR register settings should be made only when TCNT operation is stopped.

Bits 7, 6, 5—Counter Clear 2, 1, and 0 (CCLR2, CCLR1, CCLR0): These bits select the TCNT counter clearing source.

Channel	Bit 7	Bit 6	Bit 5	Description	
	CCLR2	CCLR1	CCLR0		
0, 3	0	0	0	TCNT clearing disabled (Initial value)	
			1	TCNT cleared by TGRA compare match/input capture	
			1	0	TCNT cleared by TGRB compare match/input capture
				1	TCNT cleared by counter clearing for another channel performing synchronous clearing/synchronous operation * ¹
	1	0	0	TCNT clearing disabled	
			1	TCNT cleared by TGRC compare match/input capture * ²	
			1	0	TCNT cleared by TGRD compare match/input capture * ²
				1	TCNT cleared by counter clearing for another channel performing synchronous clearing/synchronous operation * ¹

Channel	Bit 7	Bit 6	Bit 5	Description	
	Reserved* ³	CCLR1	CCLR0		
1, 2, 4, 5	0	0	0	TCNT clearing disabled (Initial value)	
			1	TCNT cleared by TGRA compare match/input capture	
			1	0	TCNT cleared by TGRB compare match/input capture
				1	TCNT cleared by counter clearing for another channel performing synchronous clearing/synchronous operation * ¹

- Notes:
1. Synchronous operation setting is performed by setting the SYNC bit in TSYR to 1.
 2. When TGRC or TGRD is used as a buffer register, TCNT is not cleared because the buffer register setting has priority, and compare match/input capture does not occur.
 3. Bit 7 is reserved in channels 1, 2, 4, and 5. It is always read as 0 and cannot be modified.

Bits 4 and 3—Clock Edge 1 and 0 (CKEG1, CKEG0): These bits select the input clock edge. When the input clock is counted using both edges, the input clock period is halved (e.g. $\phi/4$ both edges = $\phi/2$ rising edge). If phase counting mode is used on channels 1, 2, 4, and 5, this setting is ignored and the phase counting mode setting has priority.

Bit 4	Bit 3	
CKEG1	CKEG0	Description
0	0	Count at rising edge (Initial value)
	1	Count at falling edge
1	—	Count at both edges

Note: Internal clock edge selection is valid when the input clock is $\phi/4$ or slower. This setting is ignored if the input clock is $\phi/1$, or when overflow/underflow of another channel is selected.

Bits 2, 1, and 0—Time Prescaler 2, 1, and 0 (TPSC2 to TPSC0): These bits select the TCNT counter clock. The clock source can be selected independently for each channel. Table 9-4 shows the clock sources that can be set for each channel.

Table 9-4 TPU Clock Sources

Channel	Internal Clock							External Clock				Overflow/ Underflow on Another Channel
	$\phi/1$	$\phi/4$	$\phi/16$	$\phi/64$	$\phi/256$	$\phi/1024$	$\phi/4096$	TCLKA	TCLKB	TCLKC	TCLKD	
0	○	○	○	○				○	○	○	○	
1	○	○	○	○	○			○	○			○
2	○	○	○	○		○		○	○	○		
3	○	○	○	○	○	○	○	○				
4	○	○	○	○		○		○		○		○
5	○	○	○	○	○			○		○	○	

Legend

- : Setting
- Blank : No setting

Channel	Bit 2	Bit 1	Bit 0	Description	
	TPSC2	TPSC1	TPSC0		
0	0		0	Internal clock: counts on $\emptyset/1$ (Initial value)	
			1	Internal clock: counts on $\emptyset/4$	
			1	0	Internal clock: counts on $\emptyset/16$
			1	Internal clock: counts on $\emptyset/64$	
	1	0	0	External clock: counts on TCLKA pin input	
			1	External clock: counts on TCLKB pin input	
			1	0	External clock: counts on TCLKC pin input
			1	External clock: counts on TCLKD pin input	

Channel	Bit 2	Bit 1	Bit 0	Description	
	TPSC2	TPSC1	TPSC0		
1	0		0	Internal clock: counts on $\emptyset/1$ (Initial value)	
			1	Internal clock: counts on $\emptyset/4$	
			1	0	Internal clock: counts on $\emptyset/16$
			1	Internal clock: counts on $\emptyset/64$	
	1	0	0	External clock: counts on TCLKA pin input	
			1	External clock: counts on TCLKB pin input	
			1	0	Internal clock: counts on $\emptyset/256$
			1	Counts on TCNT2 overflow/underflow	

Note: This setting is ignored when channel 1 is in phase counting mode.

Channel	Bit 2	Bit 1	Bit 0	Description	
	TPSC2	TPSC1	TPSC0		
2	0		0	Internal clock: counts on $\emptyset/1$ (Initial value)	
			1	Internal clock: counts on $\emptyset/4$	
			1	0	Internal clock: counts on $\emptyset/16$
			1	Internal clock: counts on $\emptyset/64$	
	1	0	0	External clock: counts on TCLKA pin input	
			1	External clock: counts on TCLKB pin input	
			1	0	External clock: counts on TCLKC pin input
			1	Internal clock: counts on $\emptyset/1024$	

Note: This setting is ignored when channel 2 is in phase counting mode.

Channel	Bit 2	Bit 1	Bit 0	Description
	TPSC2	TPSC1	TPSC0	
3	0	0	0	Internal clock: counts on $\phi/1$ (Initial value)
			1	Internal clock: counts on $\phi/4$
			1	Internal clock: counts on $\phi/16$
			1	Internal clock: counts on $\phi/64$
	1	0	0	External clock: counts on TCLKA pin input
			1	Internal clock: counts on $\phi/1024$
			1	Internal clock: counts on $\phi/256$
			1	Internal clock: counts on $\phi/4096$

Channel	Bit 2	Bit 1	Bit 0	Description
	TPSC2	TPSC1	TPSC0	
4	0	0	0	Internal clock: counts on $\phi/1$ (Initial value)
			1	Internal clock: counts on $\phi/4$
			1	Internal clock: counts on $\phi/16$
			1	Internal clock: counts on $\phi/64$
	1	0	0	External clock: counts on TCLKA pin input
			1	External clock: counts on TCLKC pin input
			1	Internal clock: counts on $\phi/1024$
			1	Counts on TCNT5 overflow/underflow

Note: This setting is ignored when channel 4 is in phase counting mode.

Channel	Bit 2	Bit 1	Bit 0	Description
	TPSC2	TPSC1	TPSC0	
5	0	0	0	Internal clock: counts on $\phi/1$ (Initial value)
			1	Internal clock: counts on $\phi/4$
			1	Internal clock: counts on $\phi/16$
			1	Internal clock: counts on $\phi/64$
	1	0	0	External clock: counts on TCLKA pin input
			1	External clock: counts on TCLKC pin input
			1	Internal clock: counts on $\phi/256$
			1	External clock: counts on TCLKD pin input

Note: This setting is ignored when channel 5 is in phase counting mode.

9.2.2 Timer Mode Register (TMDR)

Channel 0: TMDR0

Channel 3: TMDR3

Bit	:	7	6	5	4	3	2	1	0
		—	—	BFB	BFA	MD3	MD2	MD1	MD0
Initial value	:	1	1	0	0	0	0	0	0
R/W	:	—	—	R/W	R/W	R/W	R/W	R/W	R/W

Channel 1: TMDR1

Channel 2: TMDR2

Channel 4: TMDR4

Channel 5: TMDR5

Bit	:	7	6	5	4	3	2	1	0
		—	—	—	—	MD3	MD2	MD1	MD0
Initial value	:	1	1	0	0	0	0	0	0
R/W	:	—	—	—	—	R/W	R/W	R/W	R/W

The TMDR registers are 8-bit readable/writable registers that are used to set the operating mode for each channel. The TPU has six TMDR registers, one for each channel. The TMDR registers are initialized to H'00 by a reset, and in hardware standby mode.

TMDR register settings should be made only when TCNT operation is stopped.

Bits 7 and 6—Reserved: Read-only bits, always read as 1.

Bit 5—Buffer Operation B (BFB): Specifies whether TGRB is to operate in the normal way, or TGRB and TGRD are to be used together for buffer operation. When TGRD is used as a buffer register, TGRD input capture/output compare is not generated.

In channels 1, 2, 4, and 5, which have no TGRD, bit 5 is reserved. It is always read as 0 and cannot be modified.

Bit 5

BFB	Description
0	TGRB operates normally (Initial value)
1	TGRB and TGRD used together for buffer operation

Bit 4—Buffer Operation A (BFA): Specifies whether TGRA is to operate in the normal way, or TGRA and TGRC are to be used together for buffer operation. When TGRC is used as a buffer register, TGRC input capture/output compare is not generated.

In channels 1, 2, 4, and 5, which have no TGRC, bit 4 is reserved. It is always read as 0 and cannot be modified.

Bit 4

BFA	Description
0	TGRA operates normally (Initial value)
1	TGRA and TGRC used together for buffer operation

Bits 3 to 0—Modes 3 to 0 (MD3 to MD0): These bits are used to set the timer operating mode.

Bit 3	Bit 2	Bit 1	Bit 0	Description
MD3*1	MD2*2	MD1	MD0	
0	0	0	0	Normal operation (Initial value)
			1	Reserved
		1	0	PWM mode 1
			1	PWM mode 2
	1	0	0	Phase counting mode 1
			1	Phase counting mode 2
		1	0	Phase counting mode 3
			1	Phase counting mode 4
1	*	*	*	—

*: Don't care

- Notes:
1. MD3 is a reserved bit. In a write, it should always be written with 0.
 2. Phase counting mode cannot be set for channels 0 and 3. In this case, 0 should always be written to MD2.

9.2.3 Timer I/O Control Register (TIOR)

Channel 0: TIOR0H

Channel 1: TIOR1

Channel 2: TIOR2

Channel 3: TIOR3H

Channel 4: TIOR4

Channel 5: TIOR5

Bit	:	7	6	5	4	3	2	1	0
		IOB3	IOB2	IOB1	IOB0	IOA3	IOA2	IOA1	IOA0
Initial value	:	0	0	0	0	0	0	0	0
R/W	:	R/W	R/W	R/W	R/W	R/W	R/W	R/W	R/W

Channel 0: TIOR0L

Channel 3: TIOR3L

Bit	:	7	6	5	4	3	2	1	0
		IOD3	IOD2	IOD1	IOD0	IOC3	IOC2	IOC1	IOC0
Initial value	:	0	0	0	0	0	0	0	0
R/W	:	R/W	R/W	R/W	R/W	R/W	R/W	R/W	R/W

Note: When TGRC or TGRD is designated for buffer operation, this setting is invalid and the register operates as a buffer register.

The TIOR registers are 8-bit registers that control the TGR registers. The TPU has eight TIOR registers, two each for channels 0 and 3, and one each for channels 1, 2, 4, and 5. The TIOR registers are initialized to H'00 by a reset, and in hardware standby mode.

Care is required since TIOR is affected by the TMDR setting. The initial output specified by TIOR is valid when the counter is stopped (the CST bit in TSTR is cleared to 0). Note also that, in PWM mode 2, the output at the point at which the counter is cleared to 0 is specified.

Bits 7 to 4— I/O Control B3 to B0 (IOB3 to IOB0)**I/O Control D3 to D0 (IOD3 to IOD0):**

Bits IOB3 to IOB0 specify the function of TGRB.

Bits IOD3 to IOD0 specify the function of TGRD.

	Bit 7	Bit 6	Bit 5	Bit 4				
Channel	IOB3	IOB2	IOB1	IOB0	Description			
0	0	0	0	0	TGR0B is output compare register	Output disabled	(Initial value)	
				1			Initial output is 0 output	0 output at compare match
				1			0	1 output at compare match
				1				Toggle output at compare match
	1	0	0	0	TGR0B is output compare register	Output disabled		
				1			Initial output is 1 output	0 output at compare match
				1			0	1 output at compare match
				1				Toggle output at compare match
	1	0	0	0	TGR0B is input capture register	Capture input source is TIOCB0 pin	Input capture at rising edge	
				1			Input capture at falling edge	
				1			*	Input capture at both edges
				1			*	*

*: Don't care

Note: 1. When bits TPSC2 to TPSC0 in TCR1 are set to B'000 and $\emptyset/1$ is used as the TCNT1 count clock, this setting is invalid and input capture is not generated.

Channel	Bit 7	Bit 6	Bit 5	Bit 4	Description
	IOD3	IOD2	IOD1	IOD0	
0	0	0	0	0	TGR0D is Output disabled (Initial value)
				1	output compare register*2
				0	Initial output is 0 output
				1	output at compare match
	1	0	0	0	Output disabled
				1	Initial output is 1 output
				0	output at compare match
				1	output at compare match
1	0	0	0	TGR0D is Capture input source is TIOCD0 pin	
			1	input capture register*2	
			*	Input capture at rising edge	
			*	Input capture at falling edge	
1	0	0	*	Input capture at both edges	
			*	Input capture at TCNT1 count-up/count-down*1	
1	0	0	*	Capture input source is channel 1/count clock	
			*		

*: Don't care

- Notes:
1. When bits TPSC2 to TPSC0 in TCR1 are set to B'000 and $\emptyset/1$ is used as the TCNT1 count clock, this setting is invalid and input capture is not generated.
 2. When the BFB bit in TMDR0 is set to 1 and TGR0D is used as a buffer register, this setting is invalid and input capture/output compare is not generated.

Channel	Bit 7	Bit 6	Bit 5	Bit 4	Description			
	IOB3	IOB2	IOB1	IOB0				
1	0	0	0	0	TGR1B is output compare register	Output disabled	(Initial value)	
				1			Initial output is 0	0 output at compare match
				0			output	1 output at compare match
				1				Toggle output at compare match
	1	0	0	0	TGR1B is capture register	Output disabled		
				1			Initial output is 1	0 output at compare match
				0			output	1 output at compare match
				1				Toggle output at compare match
	1	0	0	0	TGR1B is capture register	Capture input source is TIOCB1 pin	Input capture at rising edge	
				1				Input capture at falling edge
				*				Input capture at both edges
				*				Input capture at generation of TGR0C compare match/input capture

*: Don't care

Channel	Bit 7	Bit 6	Bit 5	Bit 4	Description			
	IOB3	IOB2	IOB1	IOB0				
2	0	0	0	0	TGR2B is output compare register	Output disabled	(Initial value)	
				1			Initial output is 0	0 output at compare match
				0			output	1 output at compare match
				1				Toggle output at compare match
	1	0	0	0	TGR2B is capture register	Output disabled		
				1			Initial output is 1	0 output at compare match
				0			output	1 output at compare match
				1				Toggle output at compare match
	1	*	0	0	TGR2B is capture register	Capture input source is TIOCB2 pin	Input capture at rising edge	
				1				Input capture at falling edge
				*				Input capture at both edges
				*				

*: Don't care

Channel	Bit 7	Bit 6	Bit 5	Bit 4	Description							
	IOB3	IOB2	IOB1	IOB0								
3	0	0	0	0	TGR3B is output compare register	Output disabled	(Initial value)					
				1			Initial output is 0 output	0 output at compare match				
				1			0	1 output at compare match				
				1				Toggle output at compare match				
	1	0	0	0	TGR3B is capture register	Output disabled						
				1			Initial output is 1 output	0 output at compare match				
				1			0	1 output at compare match				
				1				Toggle output at compare match				
				1			0	0	0	TGR3B is capture register	Capture input source is TIOCB3 pin	Input capture at rising edge
									1			*
1	*	*	*	TGR3B is capture register	Capture input source is channel 4/count clock	Input capture at both edges						
			*			*	Input capture at TCNT4 count-up/count-down ^{*1}					

*: Don't care

Note: 1. When bits TPSC2 to TPSC0 in TCR4 are set to B'000 and $\emptyset/1$ is used as the TCNT4 count clock, this setting is invalid and input capture is not generated.

	Bit 7	Bit 6	Bit 5	Bit 4			
Channel	IOD3	IOD2	IOD1	IOD0	Description		
3	0	0	0	0	TGR3D is Output disabled		(Initial value)
				1	output	Initial output is 0	0 output at compare match
				0	compare register*2	output	1 output at compare match
				1			Toggle output at compare match
	1	0	0	0	Output disabled		
				1	Initial output is 1	0 output at compare match	
				0	output	1 output at compare match	
				1		Toggle output at compare match	
1	0	0	0	TGR3D is Capture input	Capture input	Input capture at rising edge	
			1	input	source is	Input capture at falling edge	
			0	capture register*2	TIOCD3 pin	Input capture at both edges	
			1	*	*	Capture input	Input capture at TCNT4
					source is channel	count-up/count-down*1	
					4/count clock		

*: Don't care

- Notes: 1. When bits TPSC2 to TPSC0 in TCR4 are set to B'000 and $\emptyset/1$ is used as the TCNT4 count clock, this setting is invalid and input capture is not generated.
2. When the BFB bit in TMDR3 is set to 1 and TGR3D is used as a buffer register, this setting is invalid and input capture/output compare is not generated.

Channel	Bit 7	Bit 6	Bit 5	Bit 4	Description			
	IOB3	IOB2	IOB1	IOB0				
4	0	0	0	0	TGR4B is	Output disabled	(Initial value)	
				1	output	Initial output is 0	0 output at compare match	
				1	0	compare	output	1 output at compare match
					1	register	Toggle output at compare match	
				1	0	0	Output disabled	
							1	Initial output is 1
	1	0	1	0	output	1 output at compare match		
				1	Toggle output at compare match			
	1	0	0	0	TGR4B is	Capture input	Input capture at rising edge	
				1	input	source is	Input capture at falling edge	
				1	*	capture	TIOCB4 pin	Input capture at both edges
					1	*	register	Capture input
1				*	*	compare match/	TGR3C	TGR3C compare match/
						input capture	input capture	

*: Don't care

Channel	Bit 7	Bit 6	Bit 5	Bit 4	Description			
	IOB3	IOB2	IOB1	IOB0				
5	0	0	0	0	TGR5B is	Output disabled	(Initial value)	
				1	output	Initial output is 0	0 output at compare match	
				1	0	compare	output	1 output at compare match
					1	register	Toggle output at compare match	
				1	0	0	Output disabled	
							1	Initial output is 1
	1	0	1	0	output	1 output at compare match		
				1	Toggle output at compare match			
	1	*	0	0	TGR5B is	Capture input	Input capture at rising edge	
				1	input	source is	Input capture at falling edge	
				1	*	capture	TIOCB5 pin	Input capture at both edges
					1	*	register	Capture input
1				*	*	compare match/	TGR3C	TGR3C compare match/
						input capture	input capture	

*: Don't care

Bits 3 to 0— I/O Control A3 to A0 (IOA3 to IOA0)

I/O Control C3 to C0 (IOC3 to IOC0):

IOA3 to IOA0 specify the function of TGRA.

IOC3 to IOC0 specify the function of TGRC.

Channel	Bit 3	Bit 2	Bit 1	Bit 0	Description		
	IOA3	IOA2	IOA1	IOA0			
0	0	0	0	0	TGR0A is Output disabled (Initial value)		
				1	output compare register	Initial output is 0 output	0 output at compare match
				1	0	1 output at compare match	
				1	Toggle output at compare match		
	1	0	0	0	Output disabled		
				1	Initial output is 1 output	0 output at compare match	
				1	0	1 output at compare match	
				1	Toggle output at compare match		
	1	0	0	0	TGR0A is Capture input source is TIOCA0 pin		
				1	capture register	Input capture at rising edge	
				1	*	Input capture at falling edge	
				1	*	Input capture at both edges	
1	*	*	*	Capture input source is channel 1/ count clock	Input capture at TCNT1 count-up/count-down		

*: Don't care

Channel	Bit 3	Bit 2	Bit 1	Bit 0	Description
	IOC3	IOC2	IOC1	IOC0	
0	0	0	0	0	TGR0C is Output disabled (Initial value)
				1	output compare register*1
				0	Initial output is 0 output
				1	0 output at compare match
	1	0	0	0	Toggle output at compare match
				1	Output disabled
				0	Initial output is 1 output
				1	0 output at compare match
	1	0	0	0	1 output at compare match
				1	Toggle output at compare match
				0	Capture input source is TIOCC0 pin
				1	* Input capture at rising edge
1	0	0	0	Input capture at falling edge	
			1	* Input capture at both edges	
			*	Capture input source is channel 1/count clock	
			*	Input capture at TCNT1 count-up/count-down	

*: Don't care

Note: 1. When the BFA bit in TMDR0 is set to 1 and TGR0C is used as a buffer register, this setting is invalid and input capture/output compare is not generated.

Channel	Bit 3	Bit 2	Bit 1	Bit 0	Description			
	IOA3	IOA2	IOA1	IOA0				
1	0	0	0	0	TGR1A is output compare register	Output disabled	(Initial value)	
				1			Initial output is 0 output	0 output at compare match
				1			0	1 output at compare match
				1				Toggle output at compare match
				1			0	Output disabled
				1				Initial output is 1 output
	1	0	0	0	TGR1A is input capture register	Capture input source is TIOCA1 pin	Input capture at rising edge	
				1			Input capture at falling edge	
				1			*	Input capture at both edges
				1			*	Input capture at generation of channel 0/TGR0A compare match/input capture
				1			0	1 output at compare match
				1				Toggle output at compare match

*: Don't care

Channel	Bit 3	Bit 2	Bit 1	Bit 0	Description			
	IOA3	IOA2	IOA1	IOA0				
2	0	0	0	0	TGR2A is output compare register	Output disabled	(Initial value)	
				1			Initial output is 0 output	0 output at compare match
				1			0	1 output at compare match
				1				Toggle output at compare match
				1			0	Output disabled
				1				Initial output is 1 output
	1	*	0	0	TGR2A is input capture register	Capture input source is TIOCA2 pin	Input capture at rising edge	
				1			Input capture at falling edge	
				1			*	Input capture at both edges
				1				Toggle output at compare match
				1			0	1 output at compare match
				1				Toggle output at compare match

*: Don't care

Channel	Bit 3	Bit 2	Bit 1	Bit 0	Description
	IOA3	IOA2	IOA1	IOA0	
3	0	0	0	0	TGR3A is Output disabled (Initial value)
				1	output compare register
				0	Initial output is 0 output
				1	0 output at compare match
	1	0	0	0	Toggle output at compare match
				1	Output disabled
				0	Initial output is 1 output
				1	0 output at compare match
	1	0	0	0	1 output at compare match
				1	Toggle output at compare match
				0	Capture input source is TIOCA3 pin
				1	* Input capture at rising edge
1	0	0	0	Input capture at falling edge	
			1	* Input capture at both edges	
			*	Capture input source is channel 4/count clock	
			*	Input capture at TCNT4 count-up/count-down	

*: Don't care

	Bit 3	Bit 2	Bit 1	Bit 0			
Channel	IOC3	IOC2	IOC1	IOC0	Description		
3	0	0	0	0	TGR3C is	Output disabled	(Initial value)
				1	output	Initial output is 0	0 output at compare match
				0	compare	output	1 output at compare match
				1	register* ¹		Toggle output at compare match
				0			
				1			
	1	0	0	0		Output disabled	
				1		Initial output is 1	0 output at compare match
				0		output	1 output at compare match
				1			Toggle output at compare match
				0			
				1			
1	0	0	0	TGR3C is	Capture input	Input capture at rising edge	
			1	input	source is	Input capture at falling edge	
			0	capture	TIOCC3 pin	Input capture at both edges	
			1	register* ¹			
			*				
			*				
	1	*	*		Capture input	Input capture at TCNT4	
					source is channel	count-up/count-down	
					4/count clock		

*: Don't care

Note: 1. When the BFA bit in TMDR3 is set to 1 and TGR3C is used as a buffer register, this setting is invalid and input capture/output compare is not generated.

Channel	Bit 3	Bit 2	Bit 1	Bit 0	Description
	IOA3	IOA2	IOA1	IOA0	
4	0	0	0	0	TGR4A is Output disabled (Initial value)
				1	output
				0	Initial output is 0
				1	output
	1	0	0	0	compare register
				1	0 output at compare match
				0	1 output at compare match
				1	Toggle output at compare match
1	0	0	0	Output disabled	
			1	Initial output is 1	
			0	output	
			1	0 output at compare match	
1	0	0	0	capture register	
			1	1 output at compare match	
			0	Toggle output at compare match	
			1	Input capture at rising edge	
1	0	0	0	TGR4A is input	
			1	capture register	
			0	Input capture at falling edge	
			1	Input capture at both edges	
1	0	0	0	Capture input source is TIOCA4 pin	
			1	*	
			0	Input capture at generation of TGR3A compare match/input capture	
			1	*	

*: Don't care

Channel	Bit 3	Bit 2	Bit 1	Bit 0	Description
	IOA3	IOA2	IOA1	IOA0	
5	0	0	0	0	TGR5A is Output disabled (Initial value)
				1	output
				0	Initial output is 0
				1	output
	1	0	0	0	compare register
				1	0 output at compare match
				0	1 output at compare match
				1	Toggle output at compare match
1	0	0	0	Output disabled	
			1	Initial output is 1	
			0	output	
			1	0 output at compare match	
1	0	0	0	capture register	
			1	1 output at compare match	
			0	Toggle output at compare match	
			1	Input capture at rising edge	
1	*	0	0	TGR5A is input	
			1	capture register	
			0	Input capture at falling edge	
			1	Input capture at both edges	
1	*	0	0	Capture input source is TIOCA5 pin	
			1	*	
			0	Input capture at generation of TGR3A compare match/input capture	
			1	*	

*: Don't care

9.2.4 Timer Interrupt Enable Register (TIER)

Channel 0: TIER0

Channel 3: TIER3

Bit	:	7	6	5	4	3	2	1	0
		TTGE	—	—	TCIEV	TGIED	TGIEC	TGIEB	TGIEA
Initial value	:	0	1	0	0	0	0	0	0
R/W	:	R/W	—	—	R/W	R/W	R/W	R/W	R/W

Channel 1: TIER1

Channel 2: TIER2

Channel 4: TIER4

Channel 5: TIER5

Bit	:	7	6	5	4	3	2	1	0
		TTGE	—	TCIEU	TCIEV	—	—	TGIEB	TGIEA
Initial value	:	0	1	0	0	0	0	0	0
R/W	:	R/W	—	R/W	R/W	—	—	R/W	R/W

The TIER registers are 8-bit registers that control enabling or disabling of interrupt requests for each channel. The TPU has six TIER registers, one for each channel. The TIER registers are initialized to H'40 by a reset, and in hardware standby mode.

Bit 7—A/D Conversion Start Request Enable (TTGE): Enables or disables generation of A/D conversion start requests by TGRA input capture/compare match.

Bit 7

TTGE	Description
0	A/D conversion start request generation disabled (Initial value)
1	A/D conversion start request generation enabled

Bit 6—Reserved: Read-only bit, always read as 1.

Bit 5—Underflow Interrupt Enable (TCIEU): Enables or disables interrupt requests (TCIU) by the TCFU flag when the TCFU flag in TSR is set to 1 in channels 1 and 2.

In channels 0 and 3, bit 5 is reserved. It is always read as 0 and cannot be modified.

Bit 5

TCIEU	Description
0	Interrupt requests (TCIU) by TCFU disabled (Initial value)
1	Interrupt requests (TCIU) by TCFU enabled

Bit 4—Overflow Interrupt Enable (TCIEV): Enables or disables interrupt requests (TCIV) by the TCFV flag when the TCFV flag in TSR is set to 1.

Bit 4

TCIEV	Description
0	Interrupt requests (TCIV) by TCFV disabled (Initial value)
1	Interrupt requests (TCIV) by TCFV enabled

Bit 3—TGR Interrupt Enable D (TGIED): Enables or disables interrupt requests (TGID) by the TGFD bit when the TGFD bit in TSR is set to 1 in channels 0 and 3.

In channels 1, 2, 4, and 5, bit 3 is reserved. It is always read as 0 and cannot be modified.

Bit 3

TGIED	Description
0	Interrupt requests (TGID) by TGFD bit disabled (Initial value)
1	Interrupt requests (TGID) by TGFD bit enabled

Bit 2—TGR Interrupt Enable C (TGIEC): Enables or disables interrupt requests (TGIC) by the TGFC bit when the TGFC bit in TSR is set to 1 in channels 0 and 3.

In channels 1, 2, 4, and 5, bit 2 is reserved. It is always read as 0 and cannot be modified.

Bit 2

TGIEC	Description
0	Interrupt requests (TGIC) by TGFC bit disabled (Initial value)
1	Interrupt requests (TGIC) by TGFC bit enabled

Bit 1—TGR Interrupt Enable B (TGIEB): Enables or disables interrupt requests (TGIB) by the TGFB bit when the TGFB bit in TSR is set to 1.

Bit 1

TGIEB	Description
0	Interrupt requests (TGIB) by TGFB bit disabled (Initial value)
1	Interrupt requests (TGIB) by TGFB bit enabled

Bit 0—TGR Interrupt Enable A (TGIEA): Enables or disables interrupt requests (TGIA) by the TGFA bit when the TGFA bit in TSR is set to 1.

Bit 0

TGIEA	Description
0	Interrupt requests (TGIA) by TGFA bit disabled (Initial value)
1	Interrupt requests (TGIA) by TGFA bit enabled

9.2.5 Timer Status Register (TSR)

Channel 0: TSR0

Channel 3: TSR3

Bit	:	7	6	5	4	3	2	1	0
		—	—	—	TCFV	TGFD	TGFC	TGFB	TGFA
Initial value	:	1	1	0	0	0	0	0	0
R/W	:	—	—	—	R/(W)*	R/(W)*	R/(W)*	R/(W)*	R/(W)*

Note: * Can only be written with 0 for flag clearing.

Channel 1: TSR1

Channel 2: TSR2

Channel 4: TSR4

Channel 5: TSR5

Bit	:	7	6	5	4	3	2	1	0
		TCFD	—	TCFU	TCFV	—	—	TGFB	TGFA
Initial value	:	1	1	0	0	0	0	0	0
R/W	:	R	—	R/(W)*	R/(W)*	—	—	R/(W)*	R/(W)*

Note: * Can only be written with 0 for flag clearing.

The TSR registers are 8-bit registers that indicate the status of each channel. The TPU has six TSR registers, one for each channel. The TSR registers are initialized to H'00 by a reset, and in hardware standby mode.

Bit 7—Count Direction Flag (TCFD): Status flag that shows the direction in which TCNT counts in channels 1, 2, 4, and 5.

In channels 0 and 3, bit 7 is reserved. It is always read as 1 and cannot be modified.

Bit 7

TCFD	Description
0	TCNT counts down
1	TCNT counts up (Initial value)

Bit 6—Reserved: Read-only bit, always read as 1.

Bit 5—Underflow Flag (TCFU): Status flag that indicates that TCNT underflow has occurred when channels 1, 2, 4, and 5 are set to phase counting mode.

In channels 0 and 3, bit 5 is reserved. It is always read as 0 and cannot be modified.

Bit 5

TCFU	Description
0	[Clearing condition] When 0 is written to TCFU after reading TCFU = 1 (Initial value)
1	[Setting condition] When the TCNT value underflows (changes from H'0000 to H'FFFF)

Bit 4—Overflow Flag (TCFV): Status flag that indicates that TCNT overflow has occurred.

Bit 4

TCFV	Description
0	[Clearing condition] When 0 is written to TCFV after reading TCFV = 1 (Initial value)
1	[Setting condition] When the TCNT value overflows (changes from H'FFFF to H'0000)

Bit 3—Input Capture/Output Compare Flag D (TGFD): Status flag that indicates the occurrence of TGRD input capture or compare match in channels 0 and 3.

In channels 1, 2, 4, and 5, bit 3 is reserved. It is always read as 0 and cannot be modified.

Bit 3

TGFD	Description
0	[Clearing conditions] (Initial value) <ul style="list-style-type: none">• When DTC is activated by TGID interrupt while DISEL bit of MRB in DTC is 0• When 0 is written to TGFD after reading TGFD = 1
1	[Setting conditions] <ul style="list-style-type: none">• When TCNT = TGRD while TGRD is functioning as output compare register• When TCNT value is transferred to TGRD by input capture signal while TGRD is functioning as input capture register

Bit 2—Input Capture/Output Compare Flag C (TGFC): Status flag that indicates the occurrence of TGRC input capture or compare match in channels 0 and 3.

In channels 1, 2, 4, and 5, bit 2 is reserved. It is always read as 0 and cannot be modified.

Bit 2

TGFC	Description
0	[Clearing conditions] (Initial value) <ul style="list-style-type: none">• When DTC is activated by TGIC interrupt while DISEL bit of MRB in DTC is 0• When 0 is written to TGFC after reading TGFC = 1
1	[Setting conditions] <ul style="list-style-type: none">• When TCNT = TGRC while TGRC is functioning as output compare register• When TCNT value is transferred to TGRC by input capture signal while TGRC is functioning as input capture register

Bit 1—Input Capture/Output Compare Flag B (TGFB): Status flag that indicates the occurrence of TGRB input capture or compare match.

Bit 1

TGFB	Description
0	[Clearing conditions] (Initial value) <ul style="list-style-type: none">• When DTC is activated by TGIB interrupt while DISEL bit of MRB in DTC is 0• When 0 is written to TGFB after reading TGFB = 1
1	[Setting conditions] <ul style="list-style-type: none">• When TCNT = TGRB while TGRB is functioning as output compare register• When TCNT value is transferred to TGRB by input capture signal while TGRB is functioning as input capture register

Bit 0—Input Capture/Output Compare Flag A (TGFA): Status flag that indicates the occurrence of TGRA input capture or compare match.

Bit 0

TGFA	Description
0	[Clearing conditions] (Initial value) <ul style="list-style-type: none">• When DTC is activated by TGIA interrupt while DISEL bit of MRB in DTC is 0• When 0 is written to TGFA after reading TGFA = 1
1	[Setting conditions] <ul style="list-style-type: none">• When TCNT = TGRA while TGRA is functioning as output compare register• When TCNT value is transferred to TGRA by input capture signal while TGRA is functioning as input capture register

9.2.6 Timer Counter (TCNT)

Channel 0: TCNT0 (up-counter)

Channel 1: TCNT1 (up/down-counter*)

Channel 2: TCNT2 (up/down-counter*)

Channel 3: TCNT3 (up-counter)

Channel 4: TCNT4 (up/down-counter*)

Channel 5: TCNT5 (up/down-counter*)

Bit	:	15	14	13	12	11	10	9	8	7	6	5	4	3	2	1	0
Initial value	:	0	0	0	0	0	0	0	0	0	0	0	0	0	0	0	0
R/W	:	R/W	R/W	R/W	R/W	R/W	R/W	R/W	R/W	R/W	R/W	R/W	R/W	R/W	R/W	R/W	R/W

Note : * These counters can be used as up/down-counters only in phase counting mode or when counting overflow/underflow on another channel. In other cases they function as up-counters.

The TCNT registers are 16-bit counters. The TPU has six TCNT counters, one for each channel.

The TCNT counters are initialized to H'0000 by a reset, and in hardware standby mode.

The TCNT counters cannot be accessed in 8-bit units; they must always be accessed as a 16-bit unit.

9.2.7 Timer General Register (TGR)

Bit	:	15	14	13	12	11	10	9	8	7	6	5	4	3	2	1	0
Initial value	:	1	1	1	1	1	1	1	1	1	1	1	1	1	1	1	1
R/W	:	R/W	R/W	R/W	R/W	R/W	R/W	R/W	R/W	R/W	R/W	R/W	R/W	R/W	R/W	R/W	R/W

The TGR registers are 16-bit registers with a dual function as output compare and input capture registers. The TPU has 16 TGR registers, four each for channels 0 and 3 and two each for channels 1, 2, 4, and 5. TGRC and TGRD for channels 0 and 3 can also be designated for operation as buffer registers*. The TGR registers are initialized to H'FFFF by a reset, and in hardware standby mode.

The TGR registers cannot be accessed in 8-bit units; they must always be accessed as a 16-bit unit.

Note: * TGR buffer register combinations are TGRA—TGRC and TGRB—TGRD.

9.2.8 Timer Start Register (TSTR)

Bit	:	7	6	5	4	3	2	1	0
		—	—	CST5	CST4	CST3	CST2	CST1	CST0
Initial value	:	0	0	0	0	0	0	0	0
R/W	:	—	—	R/W	R/W	R/W	R/W	R/W	R/W

TSTR is an 8-bit readable/writable register that selects operation/stoppage for channels 0 to 5. TSTR is initialized to H'00 by a reset, and in hardware standby mode. When setting the operating mode in TMDR or setting the count clock in TCR, first stop the TCNT counter.

Bits 7 and 6—Reserved: Should always be written with 0.

Bits 5 to 0—Counter Start 5 to 0 (CST5 to CST0): These bits select operation or stoppage for TCNT.

Bit n

CSTn	Description
0	TCNTn count operation is stopped (Initial value)
1	TCNTn performs count operation

n = 5 to 0

Note: If 0 is written to the CST bit during operation with the TIOC pin designated for output, the counter stops but the TIOC pin output compare output level is retained. If TIOR is written to when the CST bit is cleared to 0, the pin output level will be changed to the set initial output value.

9.2.9 Timer Synchro Register (TSYR)

Bit	:	7	6	5	4	3	2	1	0
		—	—	SYNC5	SYNC4	SYNC3	SYNC2	SYNC1	SYNC0
Initial value	:	0	0	0	0	0	0	0	0
R/W	:	—	—	R/W	R/W	R/W	R/W	R/W	R/W

TSYR is an 8-bit readable/writable register that selects independent operation or synchronous operation for the channel 0 to 5 TCNT counters. A channel performs synchronous operation when the corresponding bit in TSYR is set to 1.

TSYR is initialized to H'00 by a reset, and in hardware standby mode.

Bits 7 and 6—Reserved: Should always be written with 0.

Bits 5 to 0—Timer Synchro 5 to 0 (SYNC5 to SYNC0): These bits select whether operation is independent of or synchronized with other channels.

When synchronous operation is selected, synchronous presetting of multiple channels*¹, and synchronous clearing through counter clearing on another channel*² are possible.

Bit n

SYNCn	Description
0	TCNTn operates independently (TCNT presetting/clearing is unrelated to other channels) (Initial value)
1	TCNTn performs synchronous operation TCNT synchronous presetting/synchronous clearing is possible

n = 5 to 0

- Notes:
1. To set synchronous operation, the SYNC bits for at least two channels must be set to 1.
 2. To set synchronous clearing, in addition to the SYNC bit, the TCNT clearing source must also be set by means of bits CCLR2 to CCLR0 in TCR.

9.2.10 Module Stop Control Register (MSTPCR)

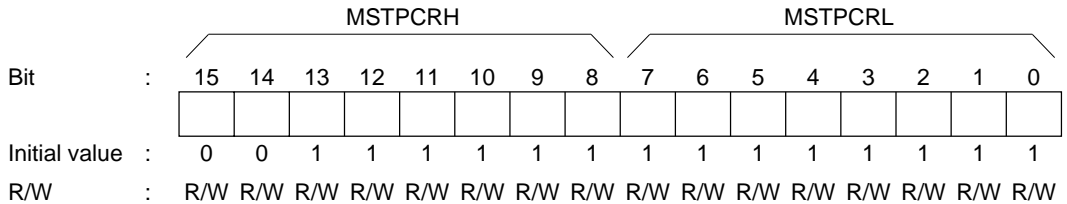

MSTPCR is a 16-bit readable/writable register that performs module stop mode control.

When the MSTP13 bit in MSTPCR is set to 1, TPU operation stops at the end of the bus cycle and a transition is made to module stop mode. Registers cannot be read or written to in module stop mode. For details, see section 19.5, Module Stop Mode.

MSTPCR is initialized to H'3FFF by a reset and in hardware standby mode. It is not initialized in software standby mode.

Bit 13—Module Stop (MSTP13): Specifies the TPU module stop mode.

Bit 13

MSTP13	Description
0	TPU module stop mode cleared
1	TPU module stop mode set (Initial value)

9.3 Interface to Bus Master

9.3.1 16-Bit Registers

TCNT and TGR are 16-bit registers. As the data bus to the bus master is 16 bits wide, these registers can be read and written to in 16-bit units.

These registers cannot be read or written to in 8-bit units; 16-bit access must always be used.

An example of 16-bit register access operation is shown in figure 9-2.

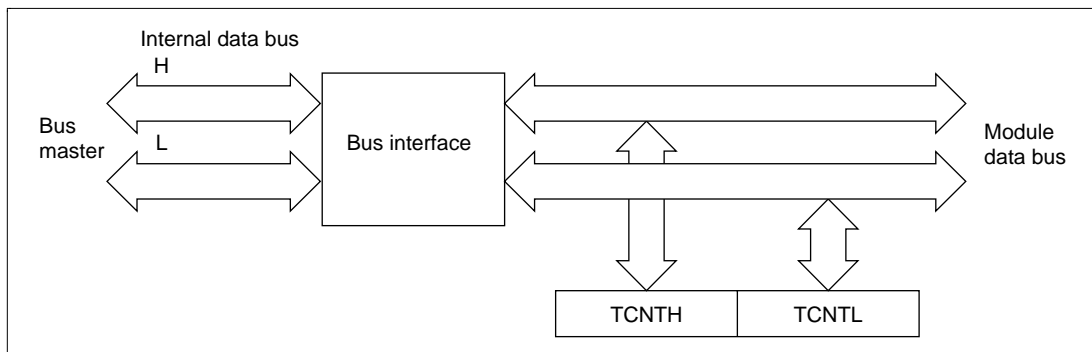

Figure 9-2 16-Bit Register Access Operation [Bus Master ↔ TCNT (16 Bits)]

9.3.2 8-Bit Registers

Registers other than TCNT and TGR are 8-bit. As the data bus to the CPU is 16 bits wide, these registers can be read and written to in 16-bit units. They can also be read and written to in 8-bit units.

Examples of 8-bit register access operation are shown in figures 9-3, 9-4, and 9-5.

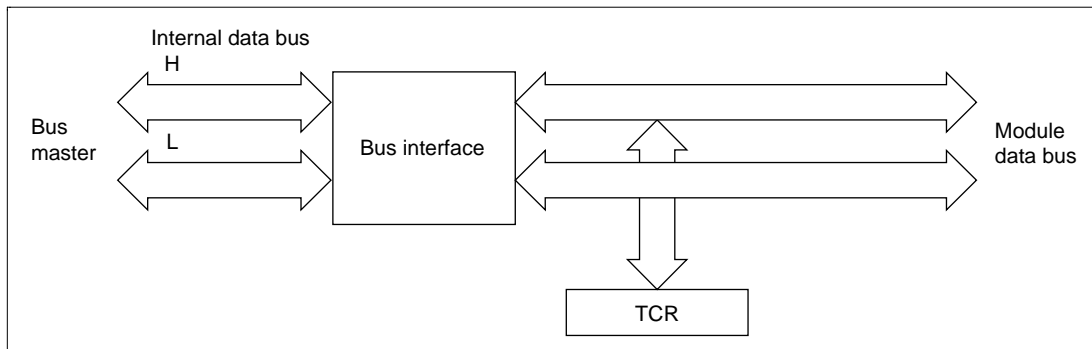

Figure 9-3 8-Bit Register Access Operation [Bus Master ↔ TCR (Upper 8 Bits)]

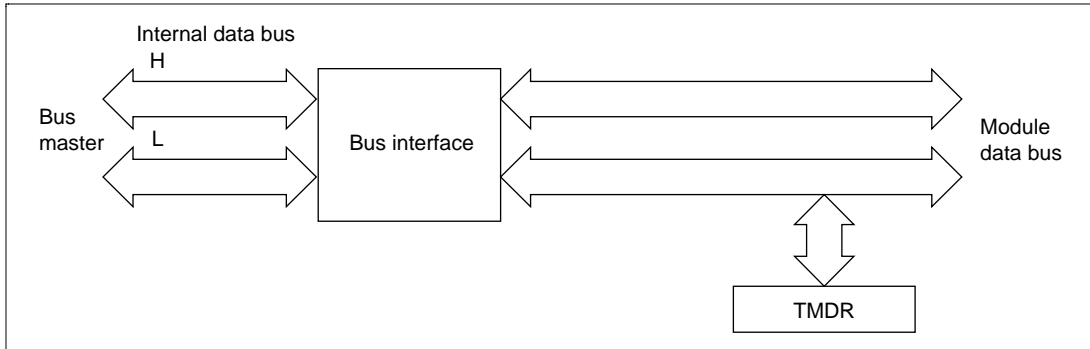

Figure 9-4 8-Bit Register Access Operation [Bus Master ↔ TMDR (Lower 8 Bits)]

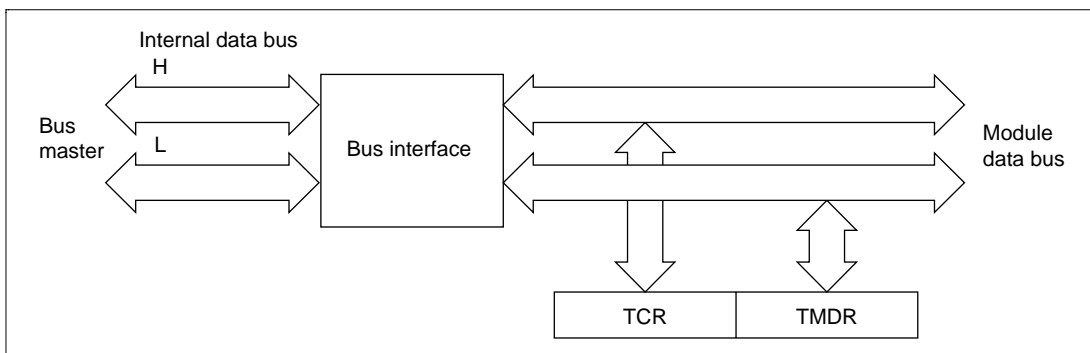

Figure 9-5 8-Bit Register Access Operation [Bus Master ↔ TCR and TMDR (16 Bits)]

9.4 Operation

9.4.1 Overview

Operation in each mode is outlined below.

Normal Operation: Each channel has a TCNT and TGR register. TCNT performs up-counting, and is also capable of free-running operation, synchronous counting, and external event counting.

Each TGR can be used as an input capture register or output compare register.

Synchronous Operation: When synchronous operation is designated for a channel, TCNT for that channel performs synchronous presetting. That is, when TCNT for a channel designated for synchronous operation is rewritten, the TCNT counters for the other channels are also rewritten at the same time. Synchronous clearing of the TCNT counters is also possible by setting the timer synchronization bits in TSYR for channels designated for synchronous operation.

Buffer Operation

- When TGR is an output compare register
When a compare match occurs, the value in the buffer register for the relevant channel is transferred to TGR.
- When TGR is an input capture register
When input capture occurs, the value in TCNT is transfer to TGR and the value previously held in TGR is transferred to the buffer register.

Cascaded Operation: The channel 1 counter (TCNT1), channel 2 counter (TCNT2), channel 4 counter (TCNT4), and channel 5 counter (TCNT5) can be connected together to operate as a 32-bit counter.

PWM Mode: In this mode, a PWM waveform is output. The output level can be set by means of TIOR. A PWM waveform with a duty of between 0% and 100% can be output, according to the setting of each TGR register.

Phase Counting Mode: In this mode, TCNT is incremented or decremented by detecting the phases of two clocks input from the external clock input pins in channels 1, 2, 4, and 5. When phase counting mode is set, the corresponding TCLK pin functions as the clock pin, and TCNT performs up- or down-counting.

This can be used for two-phase encoder pulse input.

9.4.2 Basic Functions

Counter Operation: When one of bits CST0 to CST5 is set to 1 in TSTR, the TCNT counter for the corresponding channel starts counting. TCNT can operate as a free-running counter, periodic counter, and so on.

- Example of count operation setting procedure

Figure 9-6 shows an example of the count operation setting procedure.

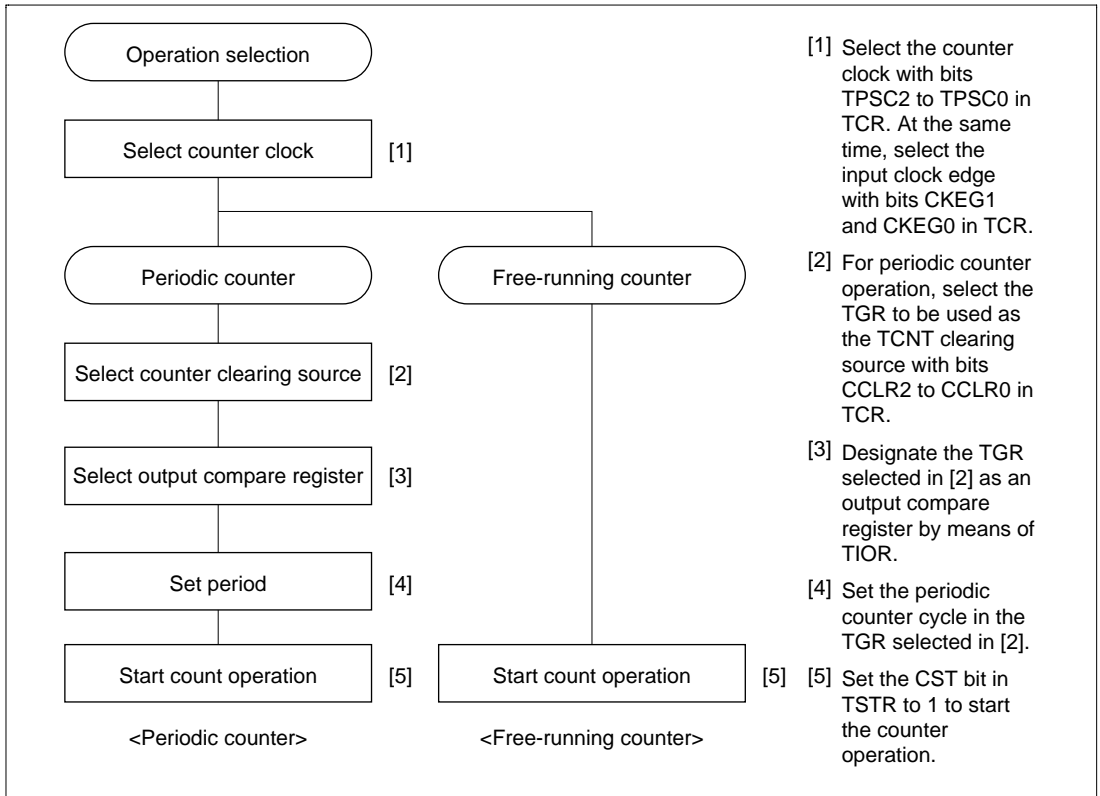

Figure 9-6 Example of Counter Operation Setting Procedure

- Free-running count operation and periodic count operation

Immediately after a reset, the TPU's TCNT counters are all designated as free-running counters. When the relevant bit in TSTR is set to 1 the corresponding TCNT counter starts up-count operation as a free-running counter. When TCNT overflows (from H'FFFF to H'0000), the TCFV bit in TSR is set to 1. If the value of the corresponding TCIEV bit in TIER is 1 at this point, the TPU requests an interrupt. After overflow, TCNT starts counting up again from H'0000.

Figure 9-7 illustrates free-running counter operation.

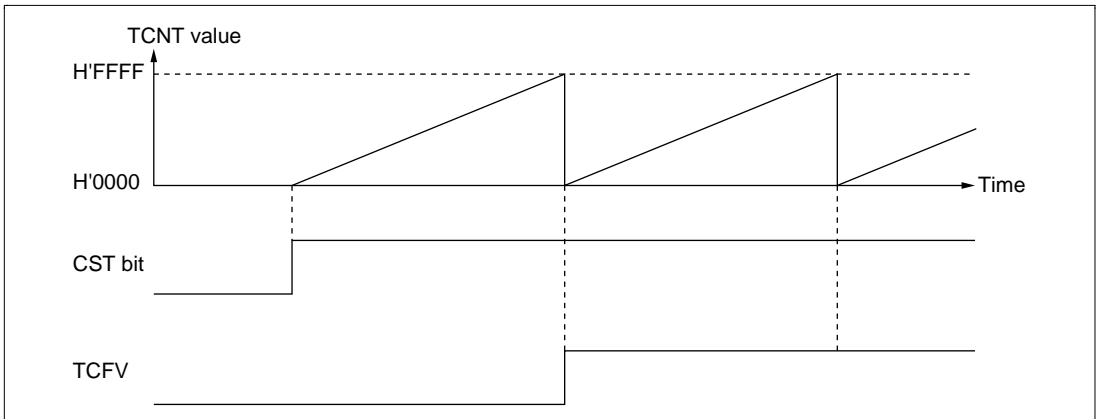

Figure 9-7 Free-Running Counter Operation

When compare match is selected as the TCNT clearing source, the TCNT counter for the relevant channel performs periodic count operation. The TGR register for setting the period is designated as an output compare register, and counter clearing by compare match is selected by means of bits CCLR2 to CCLR0 in TCR. After the settings have been made, TCNT starts up-count operation as periodic counter when the corresponding bit in TSTR is set to 1. When the count value matches the value in TGR, the TGF bit in TSR is set to 1 and TCNT is cleared to H'0000.

If the value of the corresponding TGIE bit in TIER is 1 at this point, the TPU requests an interrupt. After a compare match, TCNT starts counting up again from H'0000.

Figure 9-8 illustrates periodic counter operation.

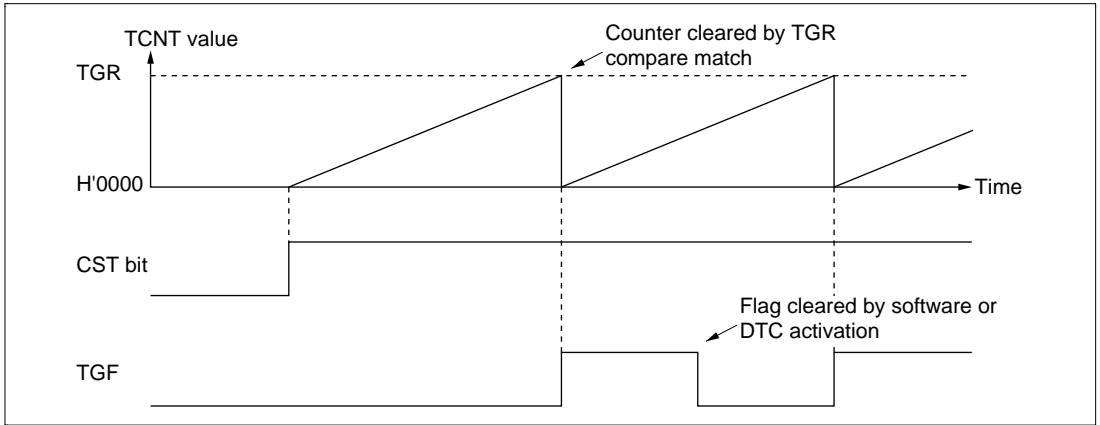

Figure 9-8 Periodic Counter Operation

Waveform Output by Compare Match: The TPU can perform 0, 1, or toggle output from the corresponding output pin using compare match.

- Example of setting procedure for waveform output by compare match

Figure 9-9 shows an example of the setting procedure for waveform output by compare match

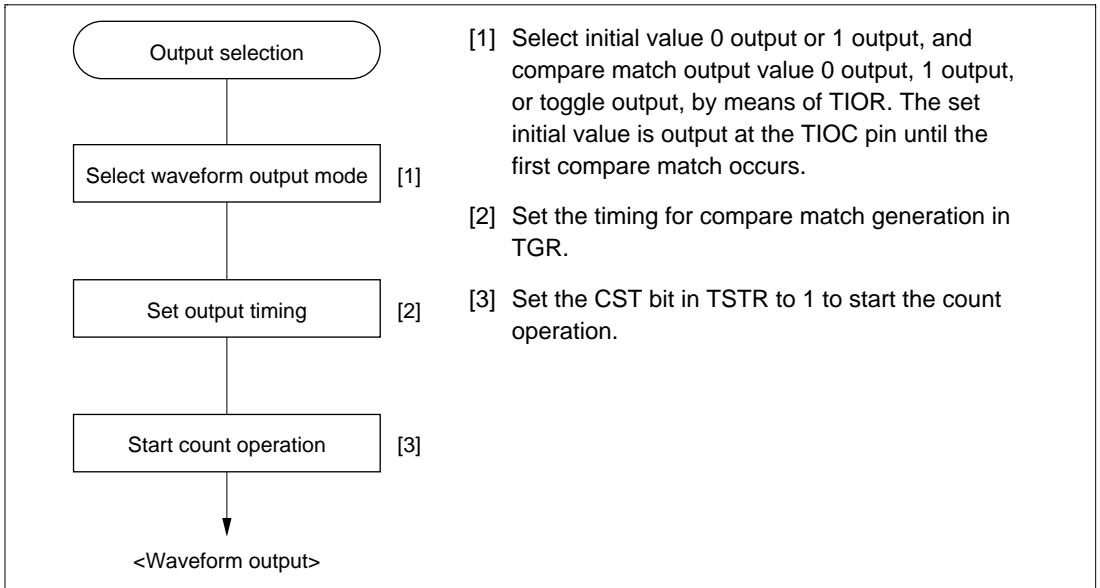

Figure 9-9 Example Of Setting Procedure For Waveform Output By Compare Match

- Examples of waveform output operation

Figure 9-10 shows an example of 0 output/1 output.

In this example TCNT has been designated as a free-running counter, and settings have been made so that 1 is output by compare match A, and 0 is output by compare match B. When the set level and the pin level coincide, the pin level does not change.

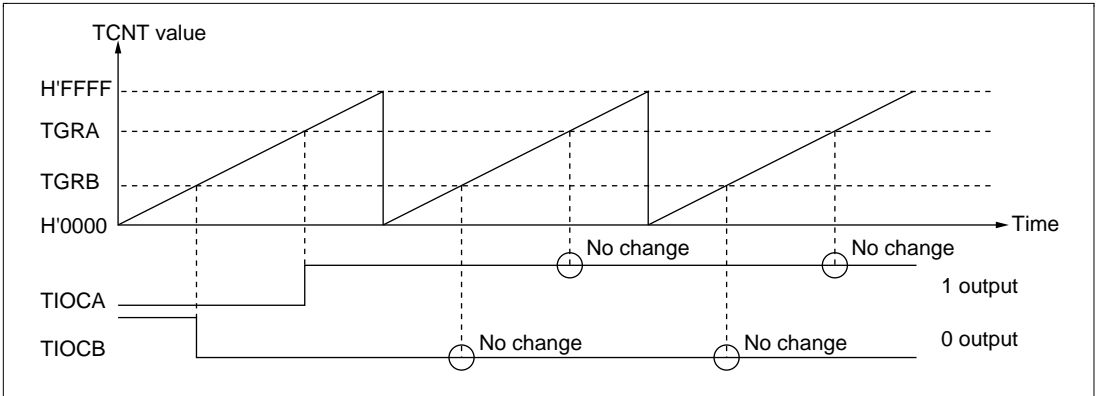

Figure 9-10 Example of 0 Output/1 Output Operation

Figure 9-11 shows an example of toggle output.

In this example TCNT has been designated as a periodic counter (with counter clearing performed by compare match B), and settings have been made so that output is toggled by both compare match A and compare match B.

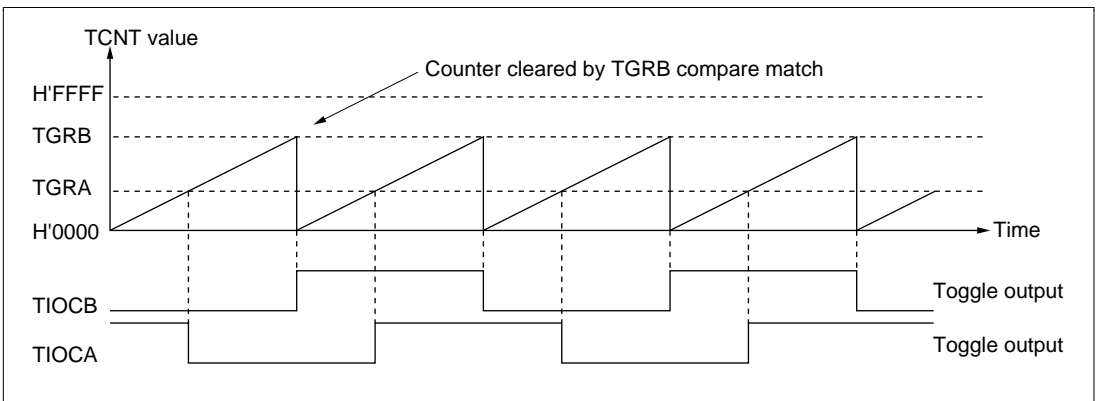

Figure 9-11 Example of Toggle Output Operation

Input Capture Function: The TCNT value can be transferred to TGR on detection of the TIOC pin input edge.

Rising edge, falling edge, or both edges can be selected as the detected edge. For channels 0, 1, 3, and 4, it is also possible to specify another channel's counter input clock or compare match signal as the input capture source.

Note: When another channel's counter input clock is used as the input capture input for channels 0 and 3, $\phi/1$ should not be selected as the counter input clock used for input capture input. Input capture will not be generated if $\phi/1$ is selected.

- Example of input capture operation setting procedure

Figure 9-12 shows an example of the input capture operation setting procedure.

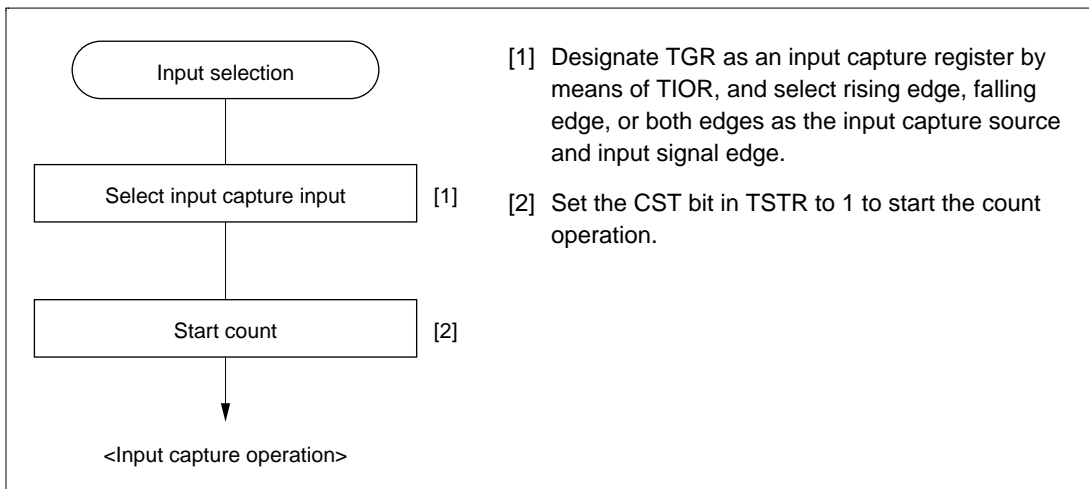

Figure 9-12 Example of Input Capture Operation Setting Procedure

- Example of input capture operation

Figure 9-13 shows an example of input capture operation.

In this example both rising and falling edges have been selected as the TIOCA pin input capture input edge, falling edge has been selected as the TIOCB pin input capture input edge, and counter clearing by TGRB input capture has been designated for TCNT.

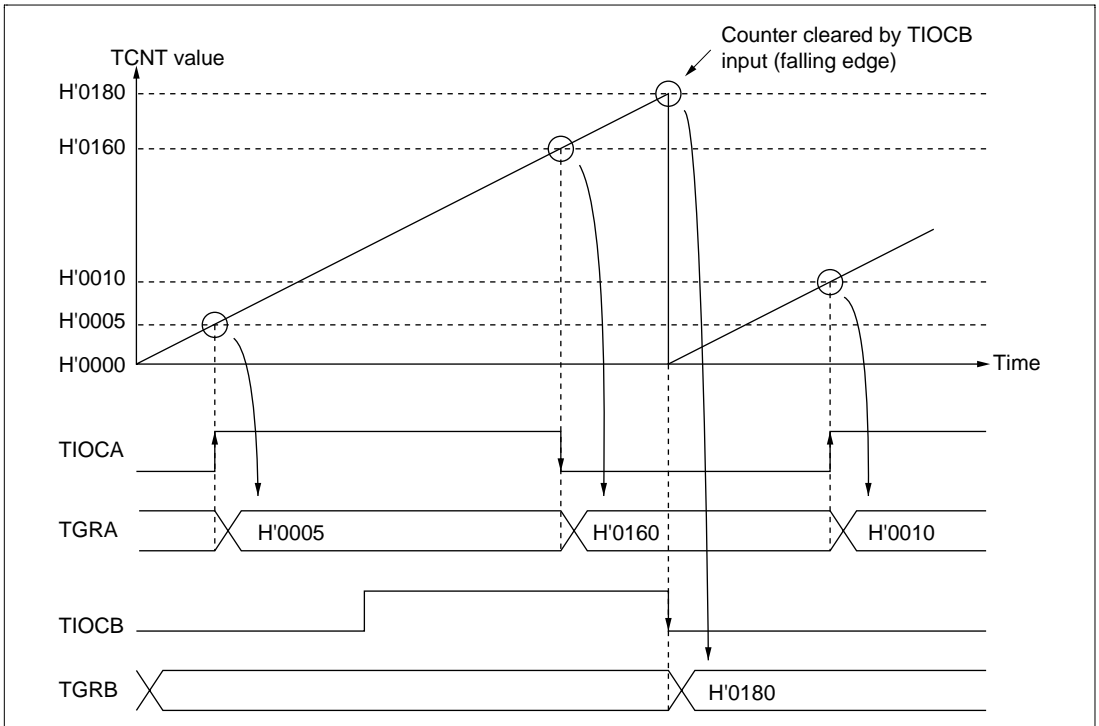

Figure 9-13 Example of Input Capture Operation

9.4.3 Synchronous Operation

In synchronous operation, the values in a number of TCNT counters can be rewritten simultaneously (synchronous presetting). Also, a number of TCNT counters can be cleared simultaneously by making the appropriate setting in TCR (synchronous clearing).

Synchronous operation enables TGR to be incremented with respect to a single time base.

Channels 0 to 5 can all be designated for synchronous operation.

Example of Synchronous Operation Setting Procedure: Figure 9-14 shows an example of the synchronous operation setting procedure.

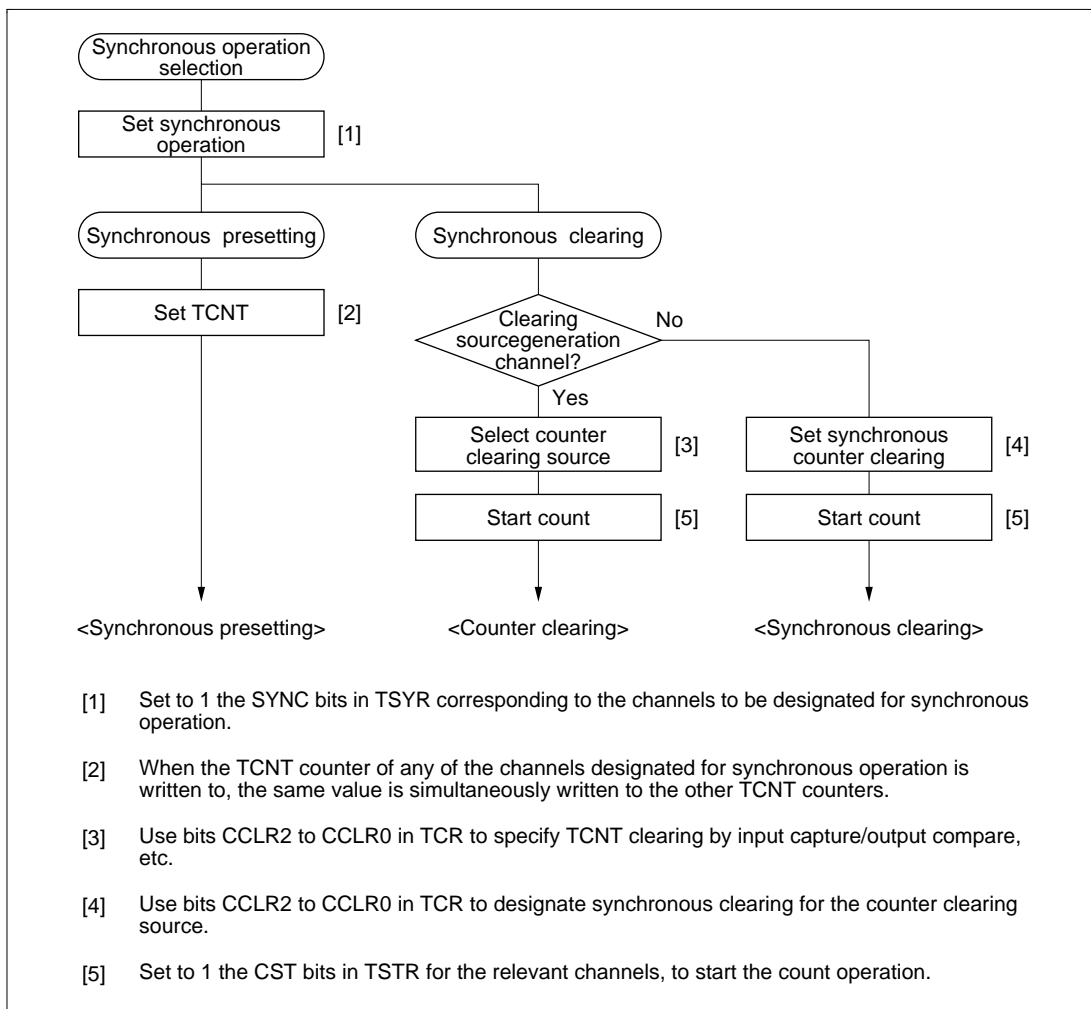

Figure 9-14 Example of Synchronous Operation Setting Procedure

Example of Synchronous Operation: Figure 9-15 shows an example of synchronous operation.

In this example, synchronous operation and PWM mode 1 have been designated for channels 0 to 2, TGR0B compare match has been set as the channel 0 counter clearing source, and synchronous clearing has been set for the channel 1 and 2 counter clearing source.

Three-phase PWM waveforms are output from pins TIOC0A, TIOC1A, and TIOC2A. At this time, synchronous presetting, and synchronous clearing by TGR0B compare match, is performed for channel 0 to 2 TCNT counters, and the data set in TGR0B is used as the PWM cycle.

For details of PWM modes, see section 9.4.6, PWM Modes.

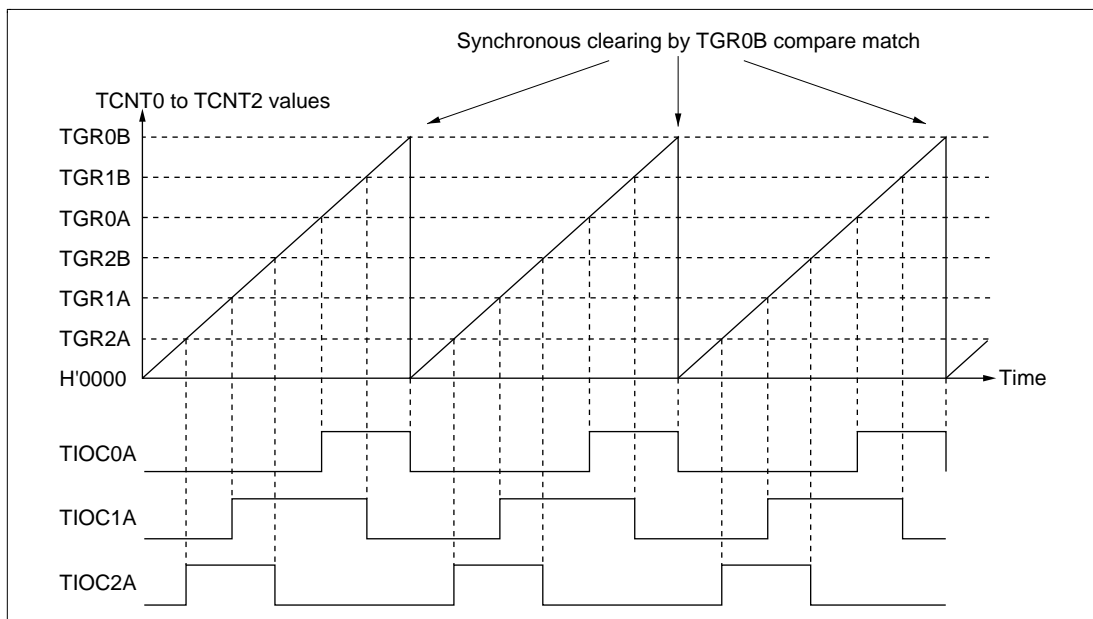

Figure 9-15 Example of Synchronous Operation

9.4.4 Buffer Operation

Buffer operation, provided for channels 0 and 3, enables TGRC and TGRD to be used as buffer registers.

Buffer operation differs depending on whether TGR has been designated as an input capture register or as a compare match register.

Table 9-5 shows the register combinations used in buffer operation.

Table 9-5 Register Combinations in Buffer Operation

Channel	Timer General Register	Buffer Register
0	TGR0A	TGR0C
	TGR0B	TGR0D
3	TGR3A	TGR3C
	TGR3B	TGR3D

- When TGR is an output compare register

When a compare match occurs, the value in the buffer register for the corresponding channel is transferred to the timer general register.

This operation is illustrated in figure 9-16.

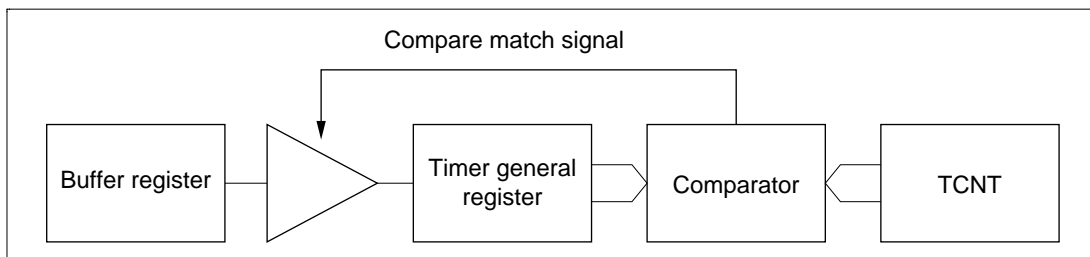

Figure 9-16 Compare Match Buffer Operation

- When TGR is an input capture register

When input capture occurs, the value in TCNT is transferred to TGR and the value previously held in the timer general register is transferred to the buffer register.

This operation is illustrated in figure 9-17.

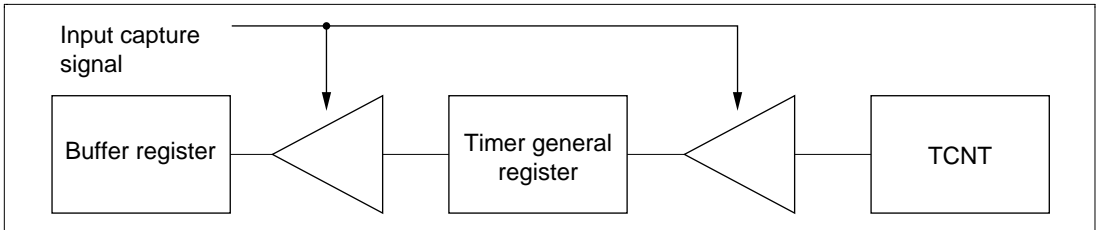

Figure 9-17 Input Capture Buffer Operation

Example of Buffer Operation Setting Procedure: Figure 9-18 shows an example of the buffer operation setting procedure.

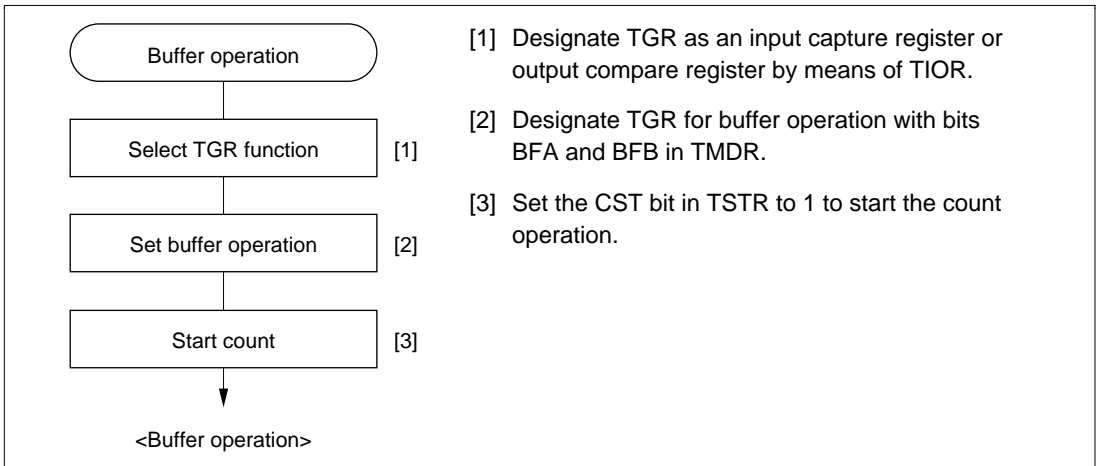

Figure 9-18 Example of Buffer Operation Setting Procedure

Examples of Buffer Operation

- When TGR is an output compare register

Figure 9-19 shows an operation example in which PWM mode 1 has been designated for channel 0, and buffer operation has been designated for TGRA and TGRC. The settings used in this example are TCNT clearing by compare match B, 1 output at compare match A, and 0 output at compare match B.

As buffer operation has been set, when compare match A occurs the output changes and the value in buffer register TGRC is simultaneously transferred to timer general register TGRA. This operation is repeated each time compare match A occurs.

For details of PWM modes, see section 9.4.6, PWM Modes.

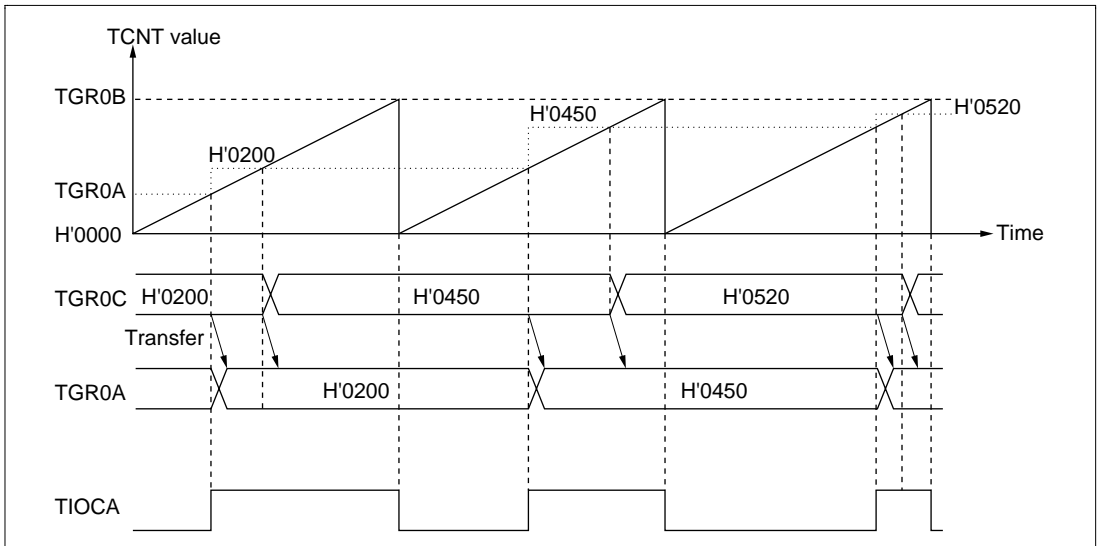

Figure 9-19 Example of Buffer Operation (1)

- When TGR is an input capture register

Figure 9-20 shows an operation example in which TGRA has been designated as an input capture register, and buffer operation has been designated for TGRA and TGRC.

Counter clearing by TGRA input capture has been set for TCNT, and both rising and falling edges have been selected as the TIOCA pin input capture input edge.

As buffer operation has been set, when the TCNT value is stored in TGRA upon occurrence of input capture A, the value previously stored in TGRA is simultaneously transferred to TGRC.

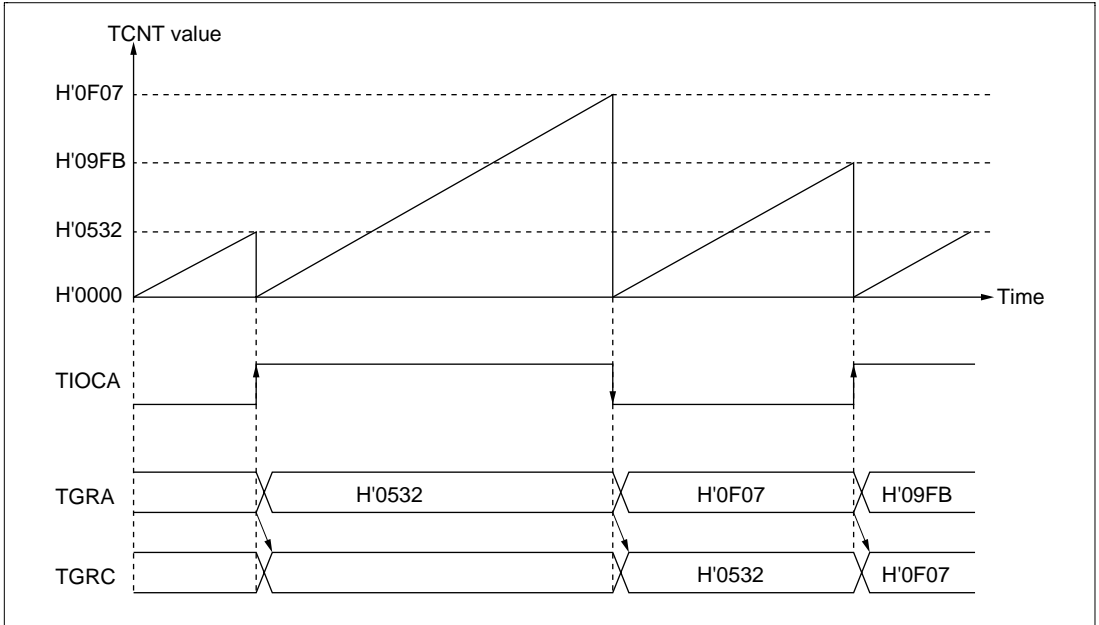

Figure 9-20 Example of Buffer Operation (2)

9.4.5 Cascaded Operation

In cascaded operation, two 16-bit counters for different channels are used together as a 32-bit counter.

This function works by counting the channel 1 (channel 4) counter clock upon overflow/underflow of TCNT2 (TCNT5) as set in bits TPSC2 to TPSC0 in TCR.

Underflow occurs only when the lower 16-bit TCNT is in phase-counting mode.

Table 9-6 shows the register combinations used in cascaded operation.

Note: When phase counting mode is set for channel 1 or 4, the counter clock setting is invalid and the counter operates independently in phase counting mode.

Table 9-6 Cascaded Combinations

Combination	Upper 16 Bits	Lower 16 Bits
Channels 1 and 2	TCNT1	TCNT2
Channels 4 and 5	TCNT4	TCNT5

Example of Cascaded Operation Setting Procedure: Figure 9-21 shows an example of the setting procedure for cascaded operation.

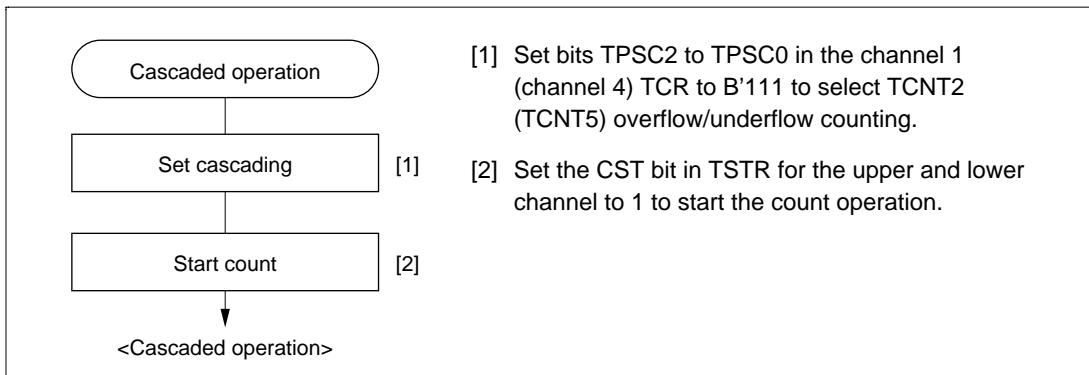

Figure 9-21 Cascaded Operation Setting Procedure

Examples of Cascaded Operation: Figure 9-22 illustrates the operation when counting upon TCNT2 overflow/underflow has been set for TCNT1, TGR1A and TGR2A have been designated as input capture registers, and TIOC pin rising edge has been selected.

When a rising edge is input to the TIOCA1 and TIOCA2 pins simultaneously, the upper 16 bits of the 32-bit data are transferred to TGR1A, and the lower 16 bits to TGR2A.

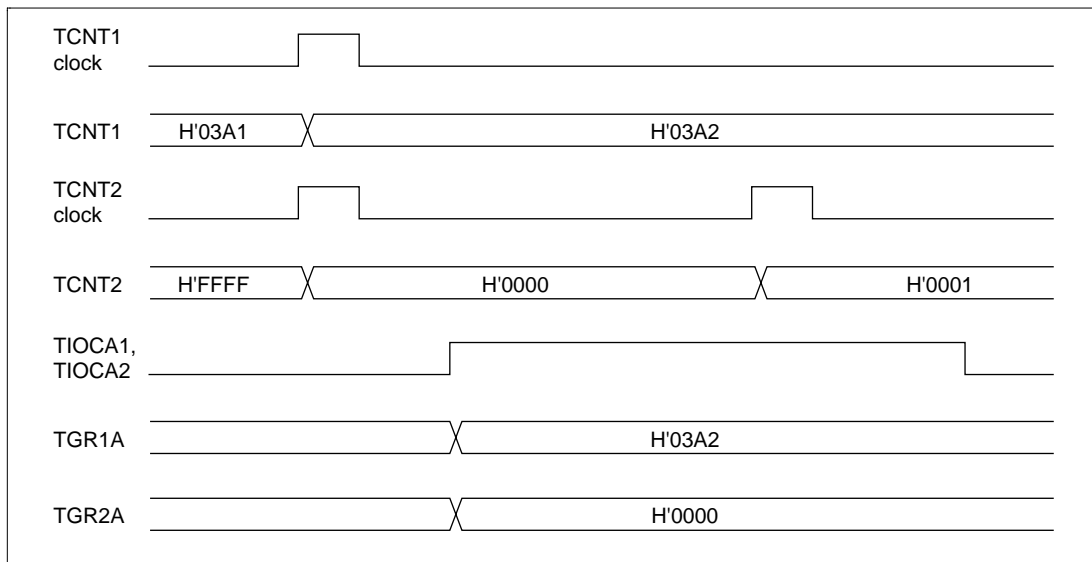

Figure 9-22 Example of Cascaded Operation (1)

Figure 9-23 illustrates the operation when counting upon TCNT2 overflow/underflow has been set for TCNT1, and phase counting mode has been designated for channel 2.

TCNT1 is incremented by TCNT2 overflow and decremented by TCNT2 underflow.

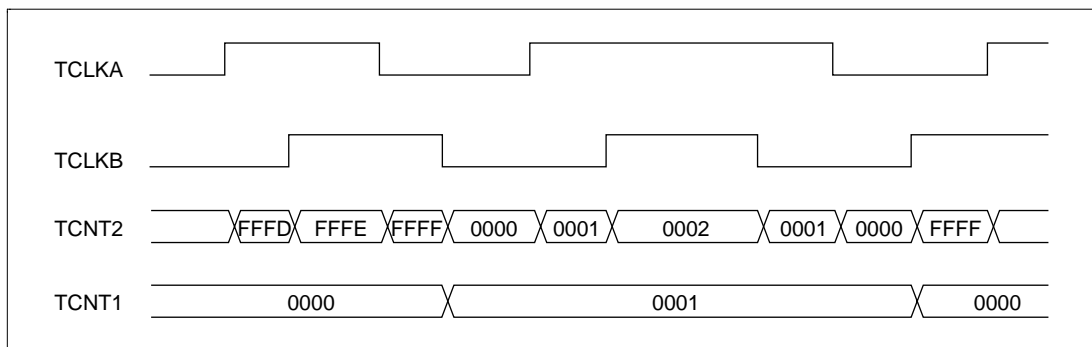

Figure 9-23 Example of Cascaded Operation (2)

9.4.6 PWM Modes

In PWM mode, PWM waveforms are output from the output pins. 0, 1, or toggle output can be selected as the output level in response to compare match of each TGR.

Designating TGR compare match as the counter clearing source enables the period to be set in that register. All channels can be designated for PWM mode independently. Synchronous operation is also possible.

There are two PWM modes, as described below.

- PWM mode 1

PWM output is generated from the TIOCA and TIOCC pins by pairing TGRA with TGRB and TGRC with TGRD. The output specified by bits IOA3 to IOA0 and IOC3 to IOC0 in TIOR is output from the TIOCA and TIOCC pins at compare matches A and C, and the output specified by bits IOB3 to IOB0 and IOD3 to IOD0 in TIOR is output at compare matches B and D. The initial output value is the value set in TGRA or TGRC. If the set values of paired TGRs are identical, the output value does not change when a compare match occurs.

In PWM mode 1, a maximum 8-phase PWM output is possible.

- PWM mode 2

PWM output is generated using one TGR as the cycle register and the others as duty registers. The output specified in TIOR is performed by means of compare matches. Upon counter clearing by a synchronization register compare match, the output value of each pin is the initial value set in TIOR. If the set values of the cycle and duty registers are identical, the output value does not change when a compare match occurs.

In PWM mode 2, a maximum 15-phase PWM output is possible by combined use with synchronous operation.

The correspondence between PWM output pins and registers is shown in table 9-7.

Table 9-7 PWM Output Registers and Output Pins

Channel	Registers	Output Pins	
		PWM Mode 1	PWM Mode 2
0	TGR0A	TIOCA0	TIOCA0
	TGR0B		TIOCB0
	TGR0C	TIOCC0	TIOCC0
	TGR0D		TIOCD0
1	TGR1A	TIOCA1	TIOCA1
	TGR1B		TIOCB1
2	TGR2A	TIOCA2	TIOCA2
	TGR2B		TIOCB2
3	TGR3A	TIOCA3	TIOCA3
	TGR3B		TIOCB3
	TGR3C	TIOCC3	TIOCC3
	TGR3D		TIOCD3
4	TGR4A	TIOCA4	TIOCA4
	TGR4B		TIOCB4
5	TGR5A	TIOCA5	TIOCA5
	TGR5B		TIOCB5

Note: In PWM mode 2, PWM output is not possible for the TGR register in which the period is set.

Example of PWM Mode Setting Procedure: Figure 9-24 shows an example of the PWM mode setting procedure.

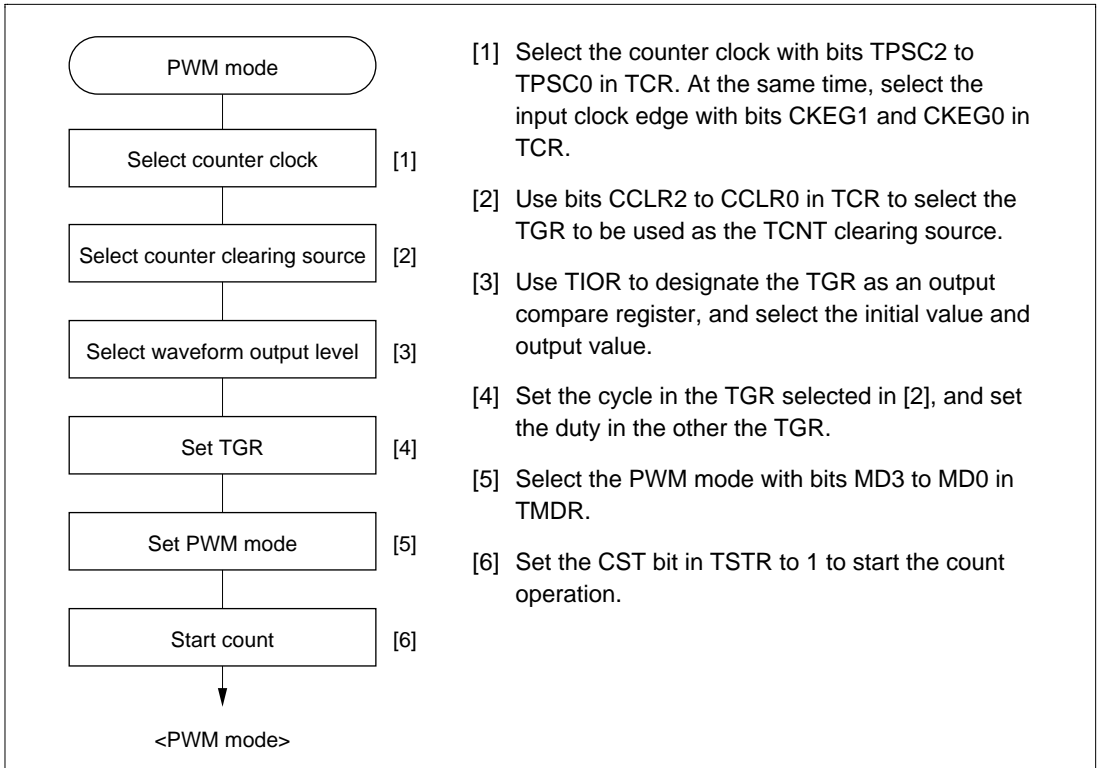

Figure 9-24 Example of PWM Mode Setting Procedure

Examples of PWM Mode Operation: Figure 9-25 shows an example of PWM mode 1 operation.

In this example, TGRA compare match is set as the TCNT clearing source, 0 is set for the TGRA initial output value and output value, and 1 is set as the TGRB output value.

In this case, the value set in TGRA is used as the period, and the values set in TGRB registers as the duty.

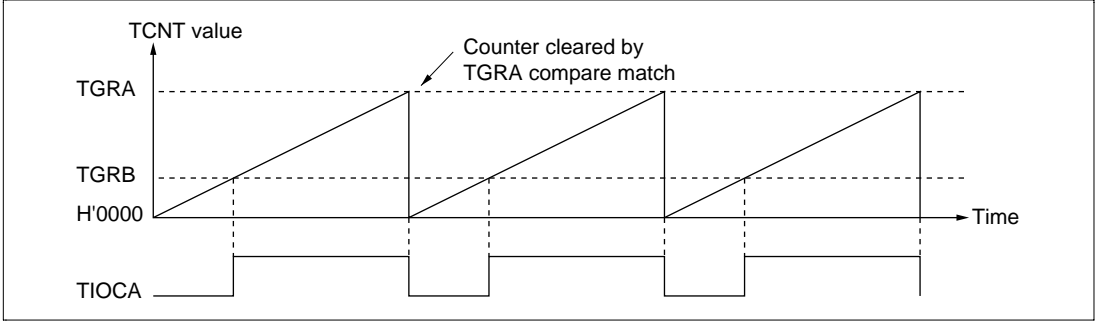

Figure 9-25 Example of PWM Mode Operation (1)

Figure 9-26 shows an example of PWM mode 2 operation.

In this example, synchronous operation is designated for channels 0 and 1, TGR1B compare match is set as the TCNT clearing source, and 0 is set for the initial output value and 1 for the output value of the other TGR registers (TGR0A to TGR0D, TGR1A), to output a 5-phase PWM waveform.

In this case, the value set in TGR1B is used as the cycle, and the values set in the other TGRs as the duty.

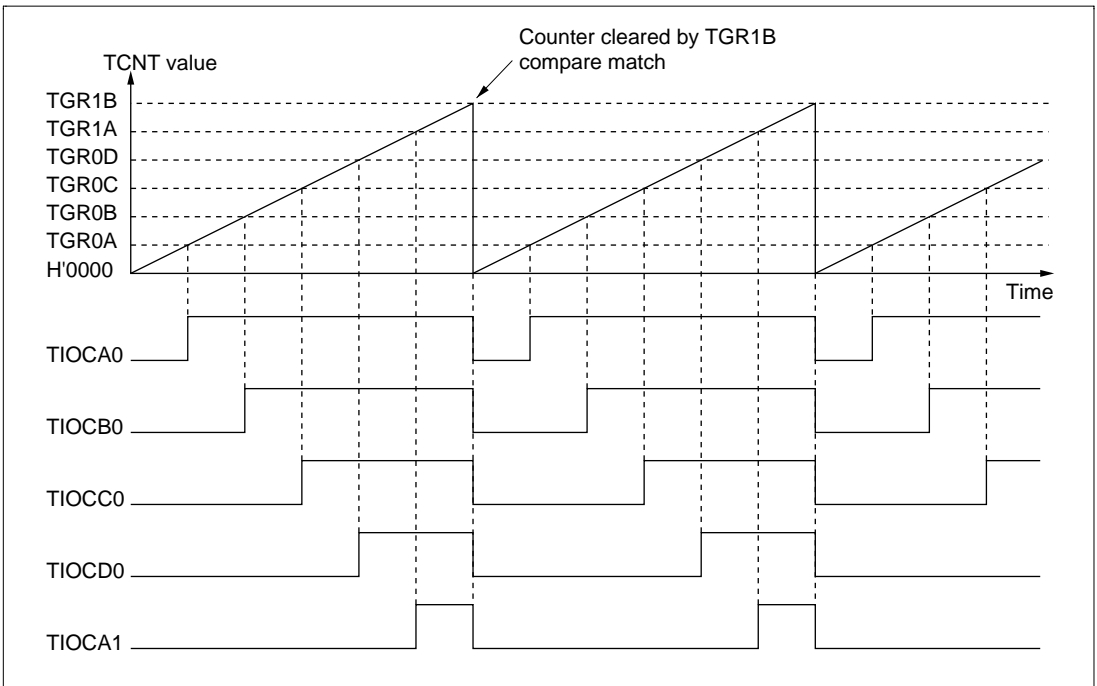

Figure 9-26 Example of PWM Mode Operation (2)

Figure 9-27 shows examples of PWM waveform output with 0% duty and 100% duty in PWM mode.

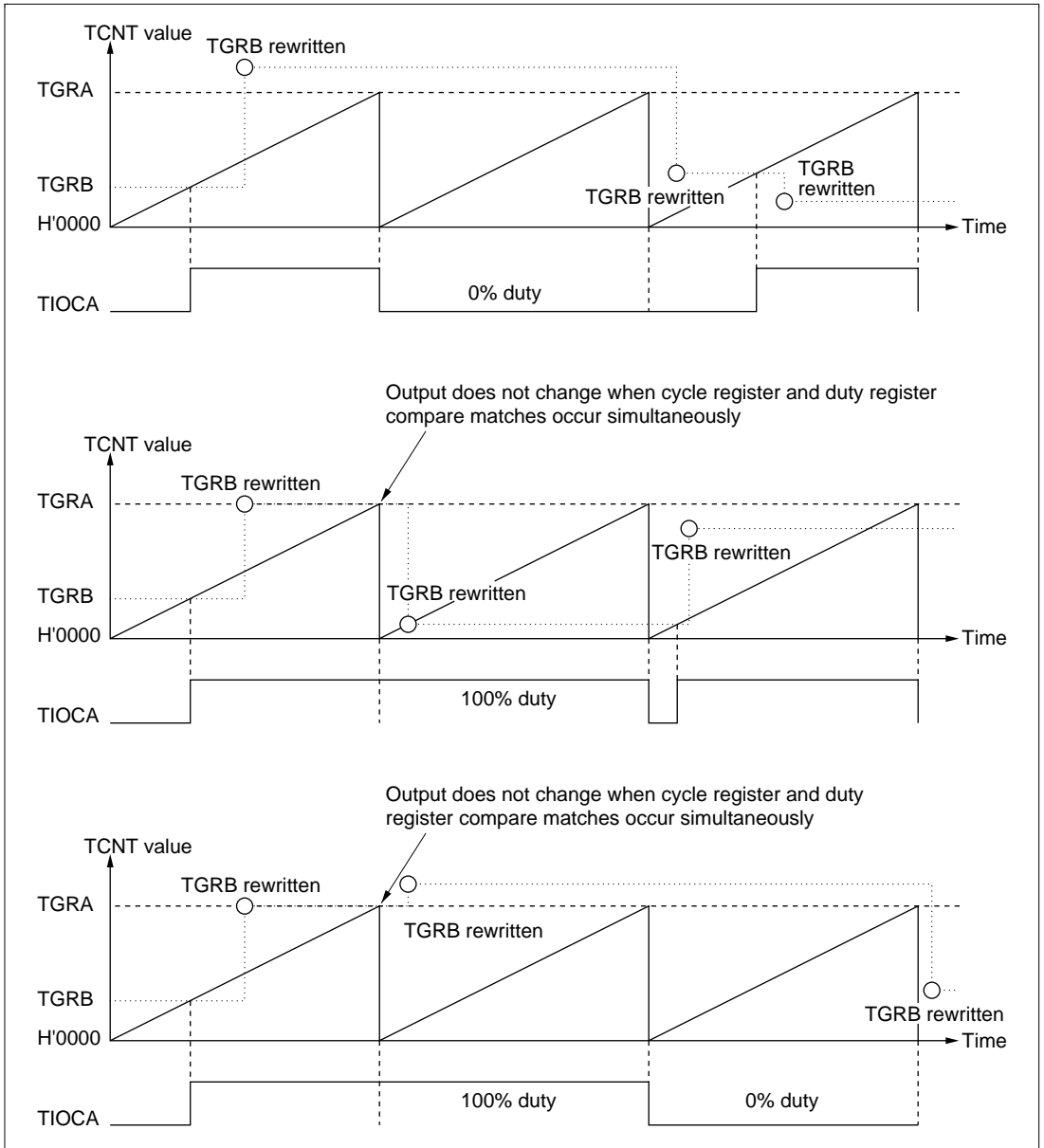

Figure 9-27 Example of PWM Mode Operation (3)

9.4.7 Phase Counting Mode

In phase counting mode, the phase difference between two external clock inputs is detected and TCNT is incremented/decremented accordingly. This mode can be set for channels 1, 2, 4, and 5.

When phase counting mode is set, an external clock is selected as the counter input clock and TCNT operates as an up/down-counter regardless of the setting of bits TPSC2 to TPSC0 and bits CKEG1 and CKEG0 in TCR. However, the functions of bits CCLR1 and CCLR0 in TCR, and of TIOR, TIER, and TGR are valid, and input capture/compare match and interrupt functions can be used.

When overflow occurs while TCNT is counting up, the TCFV flag in TSR is set; when underflow occurs while TCNT is counting down, the TCFU flag is set.

The TCFD bit in TSR is the count direction flag. Reading the TCFD flag provides an indication of whether TCNT is counting up or down.

Table 9-8 shows the correspondence between external clock pins and channels.

Table 9-8 Phase Counting Mode Clock Input Pins

Channels	External Clock Pins	
	A-Phase	B-Phase
When channel 1 or 5 is set to phase counting mode	TCLKA	TCLKB
When channel 2 or 4 is set to phase counting mode	TCLKC	TCLKD

Example of Phase Counting Mode Setting Procedure: Figure 9-28 shows an example of the phase counting mode setting procedure.

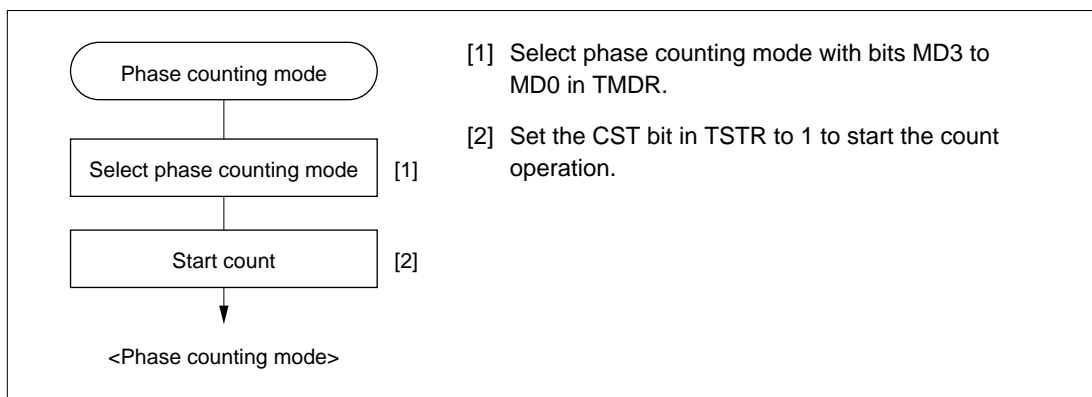

Figure 9-28 Example of Phase Counting Mode Setting Procedure

Examples of Phase Counting Mode Operation: In phase counting mode, TCNT counts up or down according to the phase difference between two external clocks. There are four modes, according to the count conditions.

- Phase counting mode 1

Figure 9-29 shows an example of phase counting mode 1 operation, and table 9-9 summarizes the TCNT up/down-count conditions.

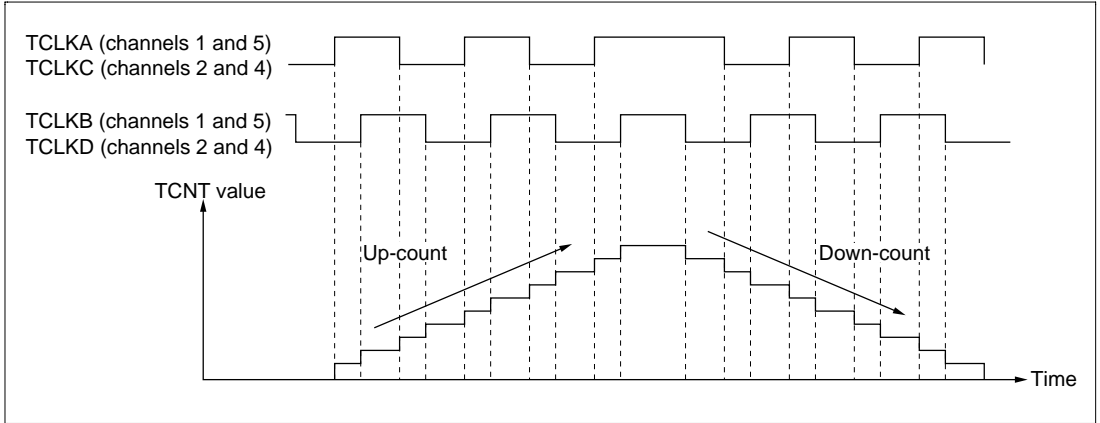

Figure 9-29 Example of Phase Counting Mode 1 Operation

Table 9-9 Up/Down-Count Conditions in Phase Counting Mode 1

TCLKA (Channels 1 and 5) TCLKC (Channels 2 and 4)	TCLKB (Channels 1 and 5) TCLKD (Channels 2 and 4)	Operation
High level		Up-count
Low level		
	Low level	Down-count
	High level	
High level		Down-count
Low level		
	High level	Up-count
	Low level	

Legend

- : Rising edge
- : Falling edge

- Phase counting mode 2

Figure 9-30 shows an example of phase counting mode 2 operation, and table 9-10 summarizes the TCNT up/down-count conditions.

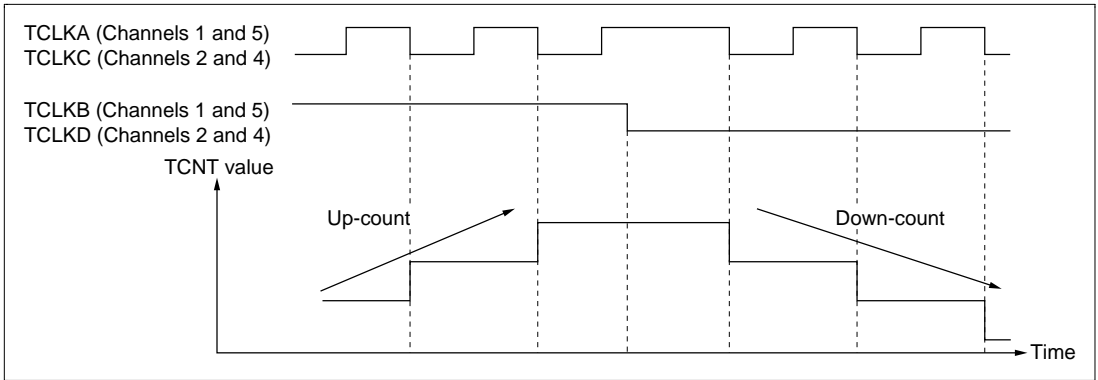

Figure 9-30 Example of Phase Counting Mode 2 Operation

Table 9-10 Up/Down-Count Conditions in Phase Counting Mode 2

TCLKA (Channels 1 and 5) TCLKC (Channels 2 and 4)	TCLKB (Channels 1 and 5) TCLKD (Channels 2 and 4)	Operation
High level		Don't care
Low level		Don't care
	Low level	Don't care
	High level	Up-count
High level		Don't care
Low level		Don't care
	High level	Don't care
	Low level	Down-count

Legend

- : Rising edge
- : Falling edge

- Phase counting mode 3

Figure 9-31 shows an example of phase counting mode 3 operation, and table 9-11 summarizes the TCNT up/down-count conditions.

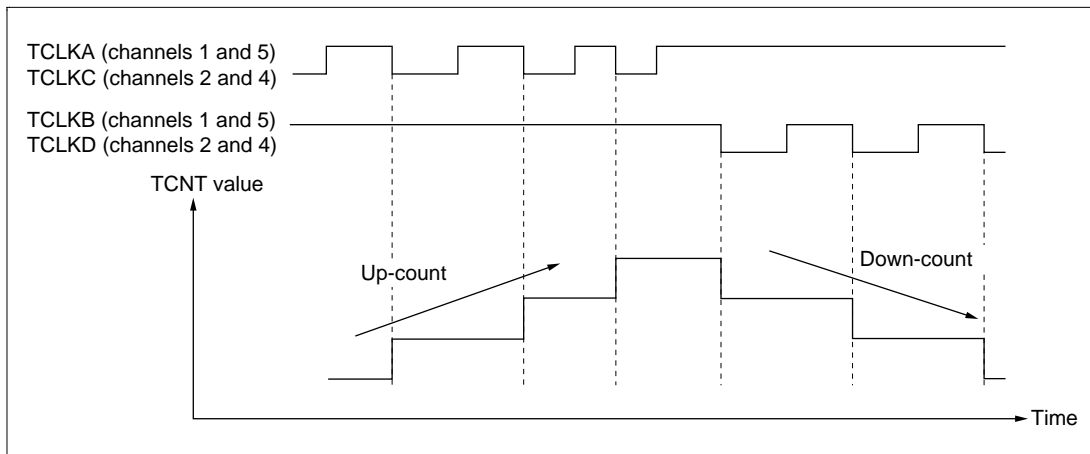

Figure 9-31 Example of Phase Counting Mode 3 Operation

Table 9-11 Up/Down-Count Conditions in Phase Counting Mode 3

TCLKA (Channels 1 and 5) TCLKC (Channels 2 and 4)	TCLKB (Channels 1 and 5) TCLKD (Channels 2 and 4)	Operation
High level		Don't care
Low level		Don't care
	Low level	Don't care
	High level	Up-count
High level		Down-count
Low level		Don't care
	High level	Don't care
	Low level	Don't care

Legend

- : Rising edge
- : Falling edge

- Phase counting mode 4

Figure 9-32 shows an example of phase counting mode 4 operation, and table 9-12 summarizes the TCNT up/down-count conditions.

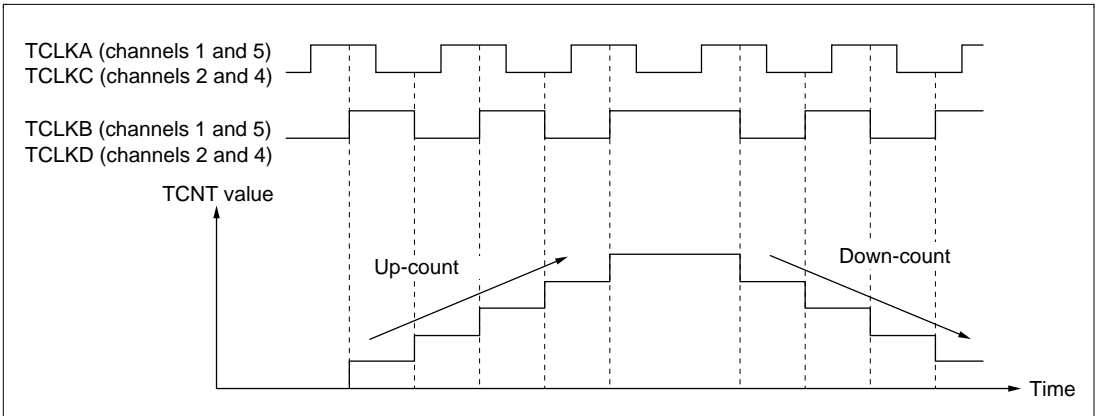

Figure 9-32 Example of Phase Counting Mode 4 Operation

Table 9-12 Up/Down-Count Conditions in Phase Counting Mode 4

TCLKA (Channels 1 and 5) TCLKC (Channels 2 and 4)	TCLKB (Channels 1 and 5) TCLKD (Channels 2 and 4)	Operation
High level	\uparrow	Up-count
Low level	\downarrow	Up-count
\uparrow	Low level	Don't care
\downarrow	High level	Don't care
High level	\downarrow	Down-count
Low level	\uparrow	Down-count
\uparrow	High level	Don't care
\downarrow	Low level	Don't care

Legend

- \uparrow : Rising edge
- \downarrow : Falling edge

Phase Counting Mode Application Example: Figure 9-33 shows an example in which phase counting mode is designated for channel 1, and channel 1 is coupled with channel 0 to input servo motor 2-phase encoder pulses in order to detect the position or speed.

Channel 1 is set to phase counting mode 1, and the encoder pulse A-phase and B-phase are input to TCLKA and TCLKB.

Channel 0 operates with TCNT counter clearing by TGR0C compare match; TGR0A and TGR0C are used for the compare match function, and are set with the speed control period and position control period. TGR0B is used for input capture, with TGR0B and TGR0D operating in buffer mode. The channel 1 counter input clock is designated as the TGR0B input capture source, and detection of the pulse width of 2-phase encoder 4-multiplication pulses is performed.

TGR1A and TGR1B for channel 1 are designated for input capture, channel 0 TGR0A and TGR0C compare matches are selected as the input capture source, and store the up/down-counter values for the control periods.

This procedure enables accurate position/speed detection to be achieved.

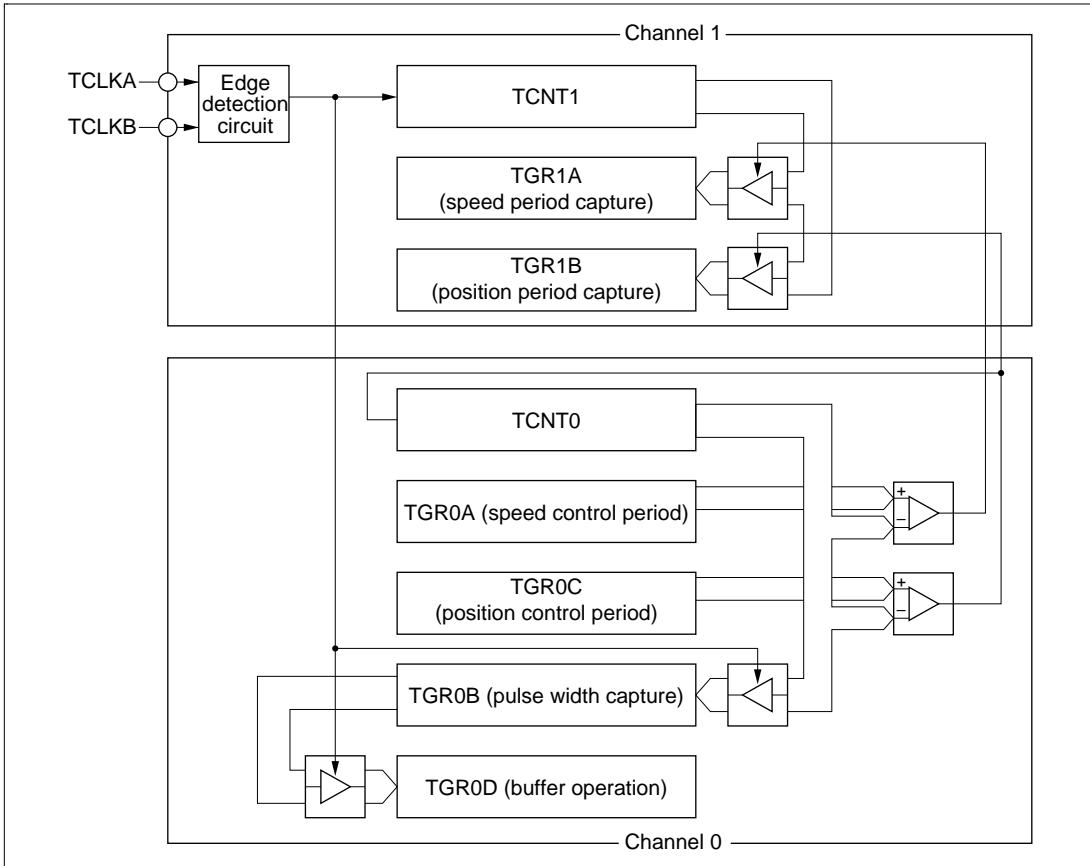

Figure 9-33 Phase Counting Mode Application Example

9.5 Interrupts

9.5.1 Interrupt Sources and Priorities

There are three kinds of TPU interrupt source: TGR input capture/compare match, TCNT overflow, and TCNT underflow. Each interrupt source has its own status flag and enable/disable bit, allowing generation of interrupt request signals to be enabled or disabled individually.

When an interrupt request is generated, the corresponding status flag in TSR is set to 1. If the corresponding enable/disable bit in TIER is set to 1 at this time, an interrupt is requested. The interrupt request is cleared by clearing the status flag to 0.

Relative channel priorities can be changed by the interrupt controller, but the priority order within a channel is fixed. For details, see section 5, Interrupt Controller.

Input Capture/Compare Match Interrupt: An interrupt is requested if the TGIE bit in TIER is set to 1 when the TGF flag in TSR is set to 1 by the occurrence of a TGR input capture/compare match on a particular channel. The interrupt request is cleared by clearing the TGF flag to 0. The TPU has 16 input capture/compare match interrupts, four each for channels 0 and 3, and two each for channels 1, 2, 4, and 5.

Overflow Interrupt: An interrupt is requested if the TCIEV bit in TIER is set to 1 when the TCFV flag in TSR is set to 1 by the occurrence of TCNT overflow on a channel. The interrupt request is cleared by clearing the TCFV flag to 0. The TPU has six overflow interrupts, one for each channel.

Underflow Interrupt: An interrupt is requested if the TCIEU bit in TIER is set to 1 when the TCFU flag in TSR is set to 1 by the occurrence of TCNT underflow on a channel. The interrupt request is cleared by clearing the TCFU flag to 0. The TPU has four overflow interrupts, one each for channels 1, 2, 4, and 5.

9.5.2 DTC Activation

DTC Activation: The DTC can be activated by the TGR input capture/compare match interrupt for a channel. For details, see section 7, Data Transfer Controller.

A total of 16 TPU input capture/compare match interrupts can be used as DTC activation sources, four each for channels 0 and 3, and two each for channels 1, 2, 4, and 5.

9.5.3 A/D Converter Activation

The A/D converter can be activated by the TGRA input capture/compare match for a channel.

If the TTGE bit in TIER is set to 1 when the TGFA flag in TSR is set to 1 by the occurrence of a TGRA input capture/compare match on a particular channel, a request to start A/D conversion is sent to the A/D converter. If the TPU conversion start trigger has been selected on the A/D converter side at this time, A/D conversion is started.

In the TPU, a total of six TGRA input capture/compare match interrupts can be used as A/D converter conversion start sources, one for each channel.

9.6 Operation Timing

9.6.1 Input/Output Timing

TCNT Count Timing: Figure 9-34 shows TCNT count timing in internal clock operation, and figure 9-35 shows TCNT count timing in external clock operation.

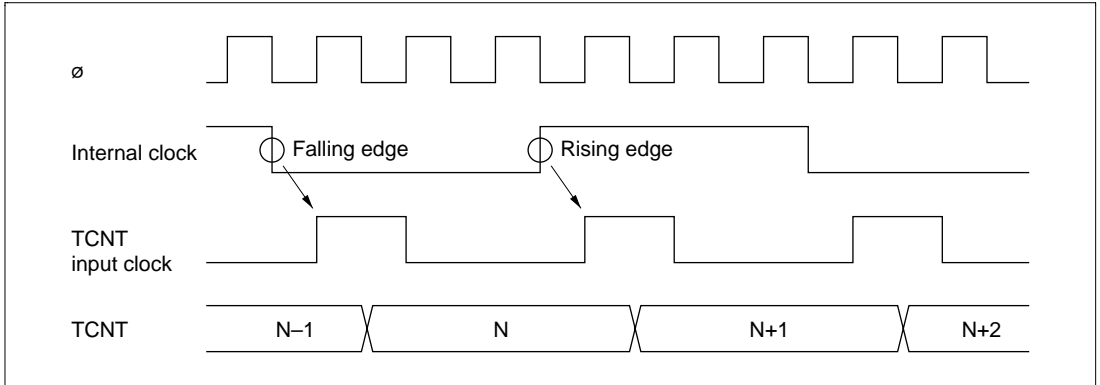

Figure 9-34 Count Timing in Internal Clock Operation

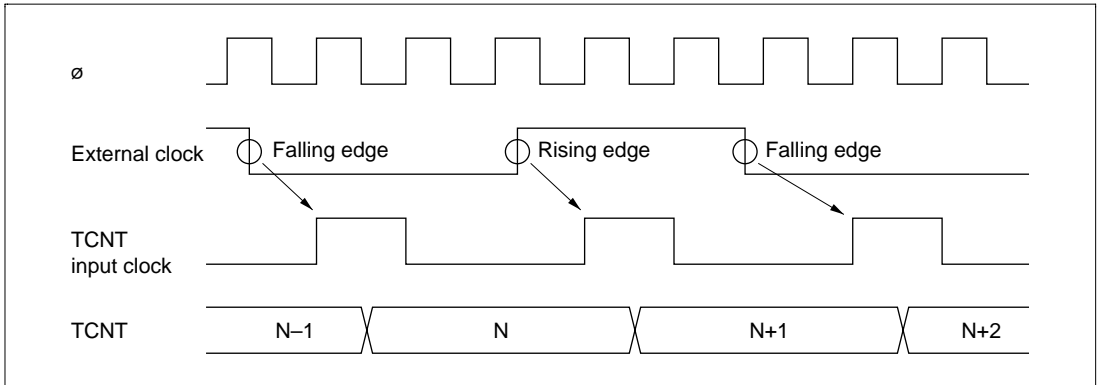

Figure 9-35 Count Timing in External Clock Operation

Output Compare Output Timing: A compare match signal is generated in the final state in which TCNT and TGR match (the point at which the count value matched by TCNT is updated). When a compare match signal is generated, the output value set in TIOR is output at the output compare output pin. After a match between TCNT and TGR, the compare match signal is not generated until the TCNT input clock is generated.

Figure 9-36 shows output compare output timing.

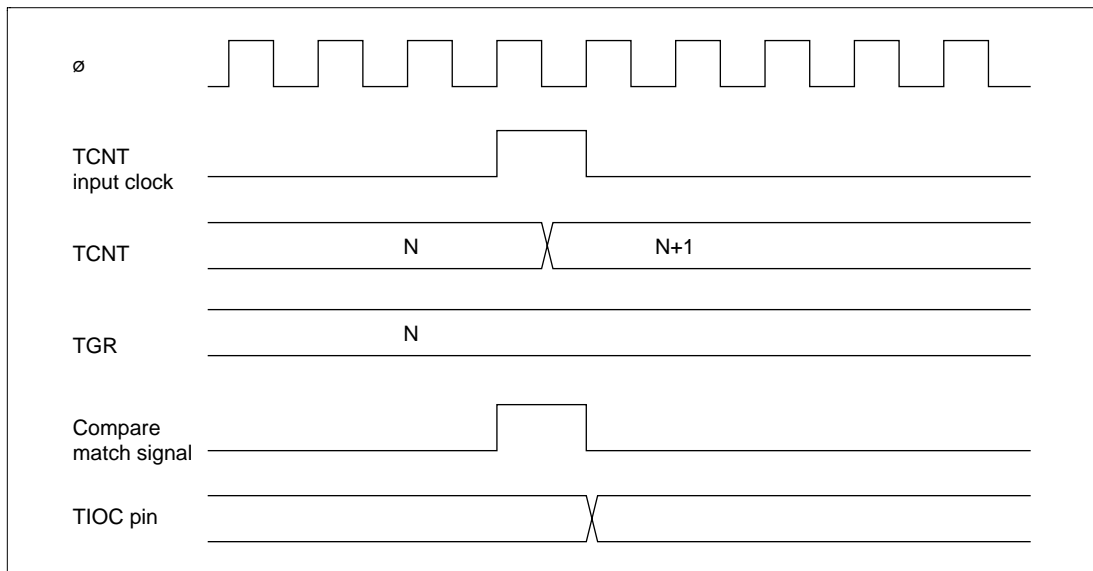

Figure 9-36 Output Compare Output Timing

Input Capture Signal Timing: Figure 9-37 shows input capture signal timing.

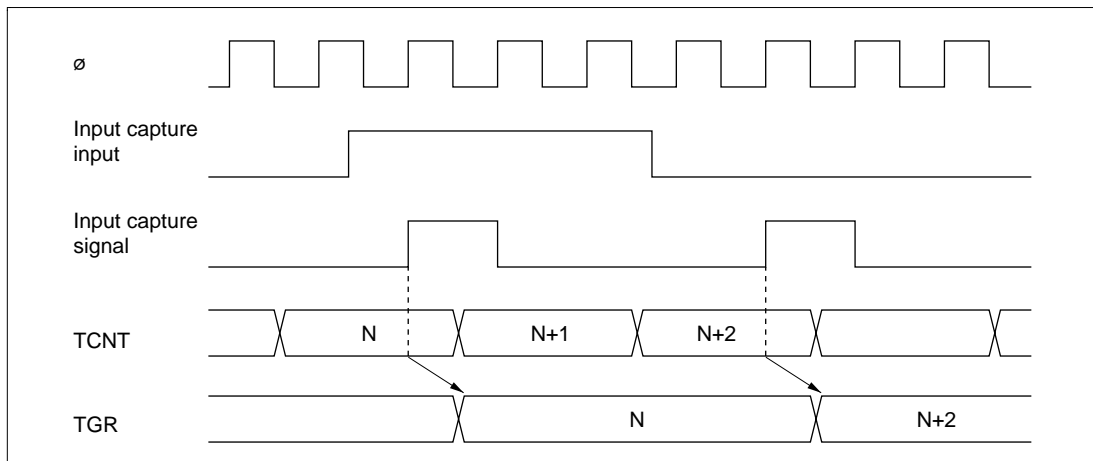

Figure 9-37 Input Capture Input Signal Timing

Timing for Counter Clearing by Compare Match/Input Capture: Figure 9-38 shows the timing when counter clearing by compare match occurrence is specified, and figure 9-39 shows the timing when counter clearing by input capture occurrence is specified.

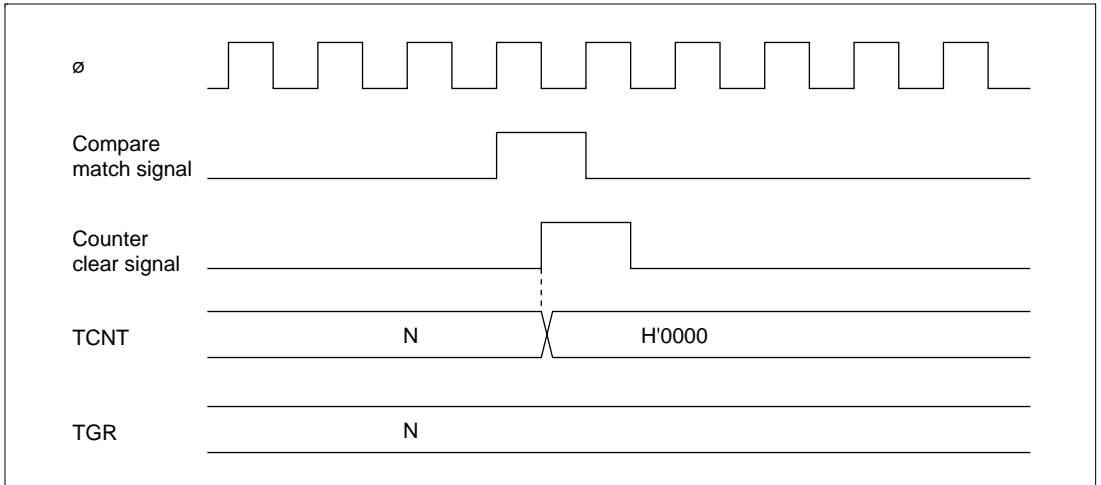

Figure 9-38 Counter Clear Timing (Compare Match)

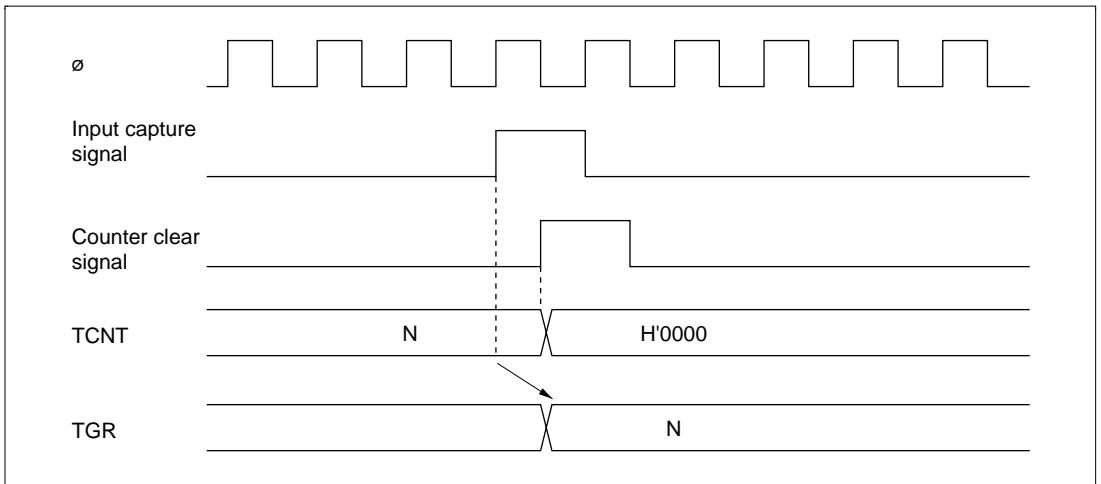

Figure 9-39 Counter Clear Timing (Input Capture)

Buffer Operation Timing: Figures 9-40 and 9-41 show the timing in buffer operation.

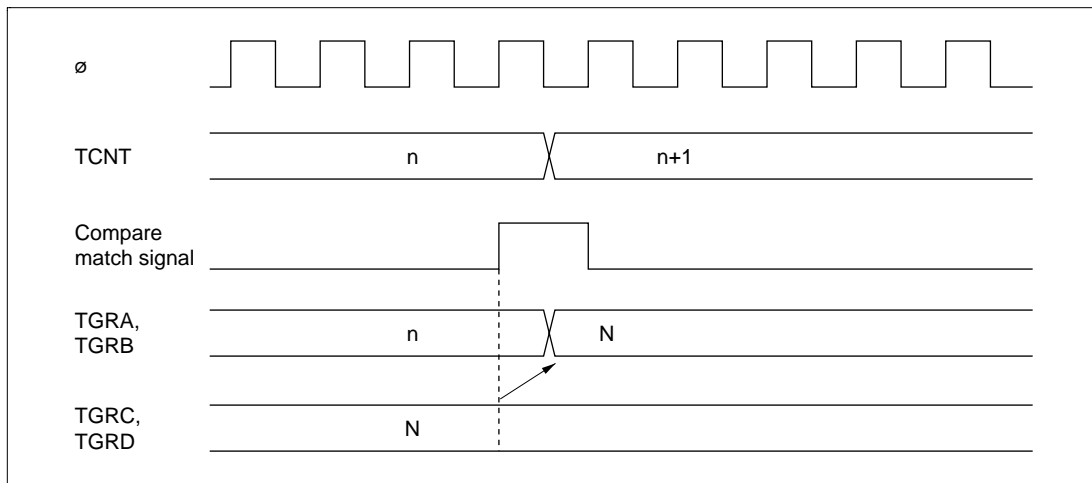

Figure 9-40 Buffer Operation Timing (Compare Match)

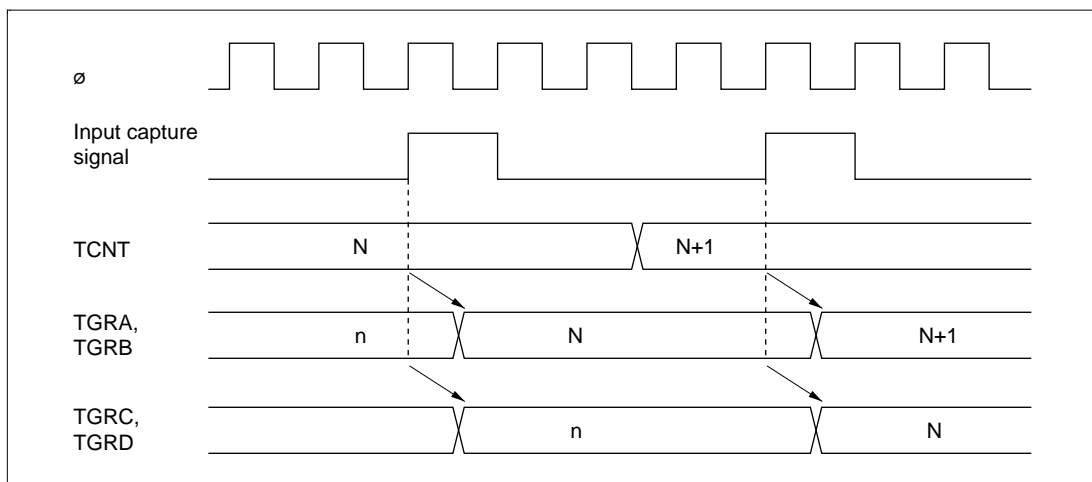

Figure 9-41 Buffer Operation Timing (Input Capture)

9.6.2 Interrupt Signal Timing

TGF Flag Setting Timing in Case of Compare Match: Figure 9-42 shows the timing for setting of the TGF flag in TSR by compare match occurrence, and TGI interrupt request signal timing.

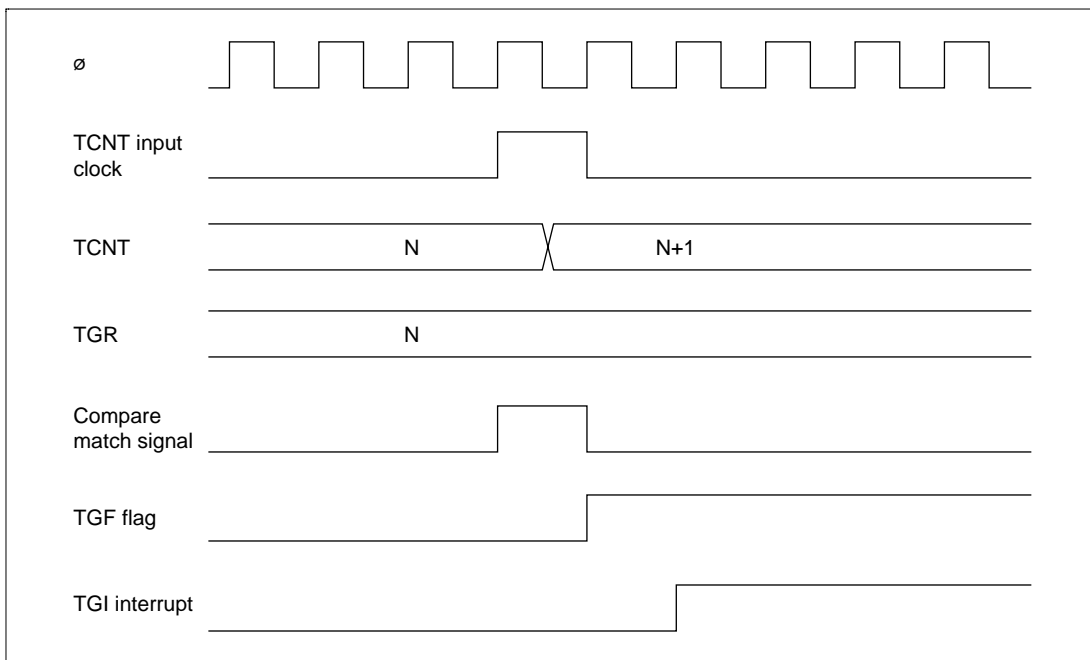

Figure 9-42 TGI Interrupt Timing (Compare Match)

TGF Flag Setting Timing in Case of Input Capture: Figure 9-43 shows the timing for setting of the TGF flag in TSR by input capture occurrence, and TGI interrupt request signal timing.

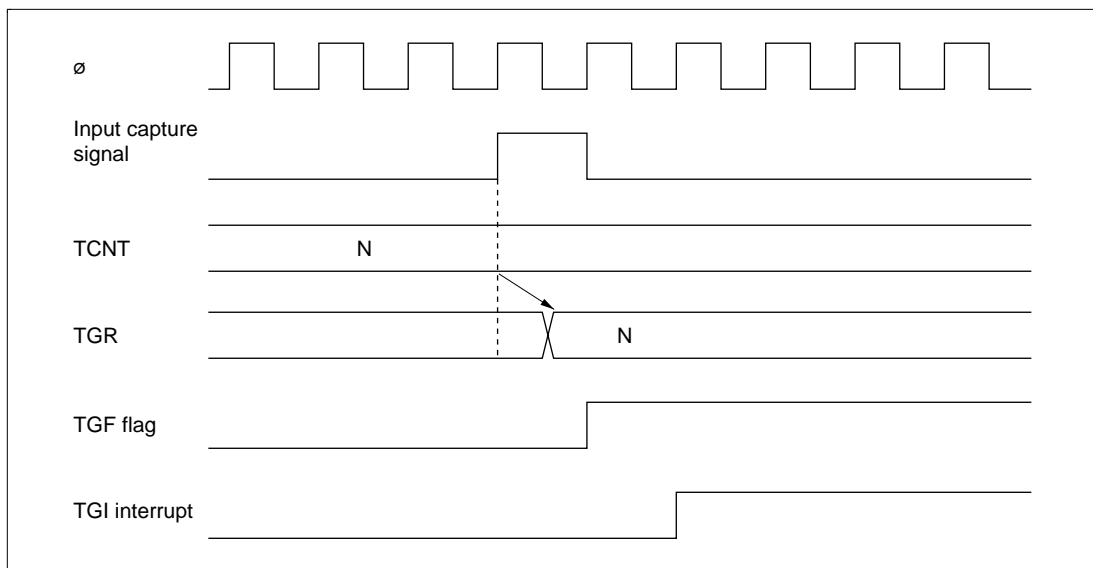

Figure 9-43 TGI Interrupt Timing (Input Capture)

TCFV Flag/TCFU Flag Setting Timing: Figure 9-44 shows the timing for setting of the TCFV flag in TSR by overflow occurrence, and TCIV interrupt request signal timing.

Figure 9-45 shows the timing for setting of the TCFU flag in TSR by underflow occurrence, and TCIU interrupt request signal timing.

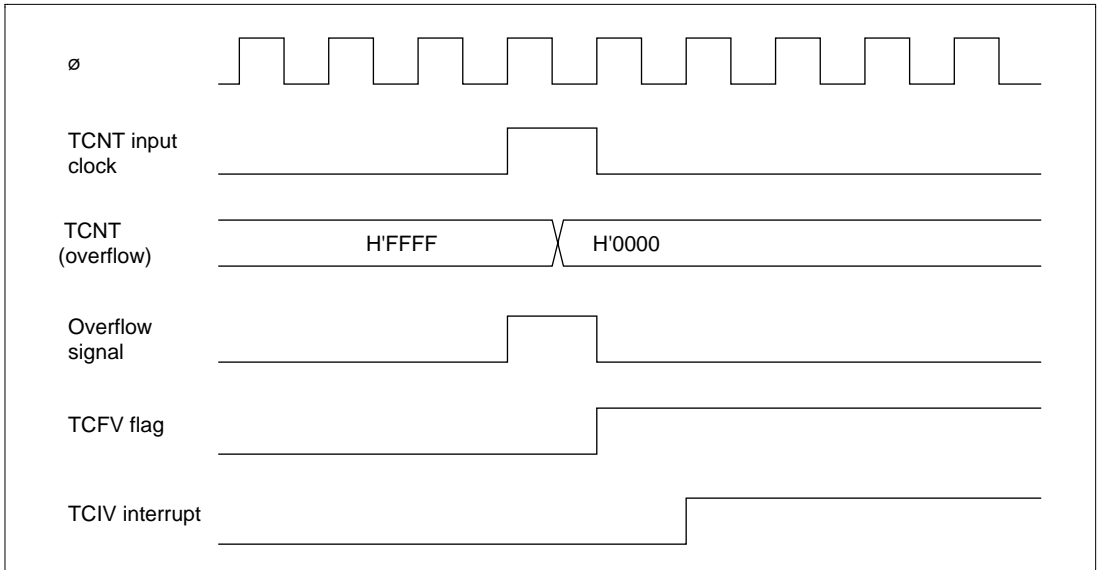

Figure 9-44 TCIV Interrupt Setting Timing

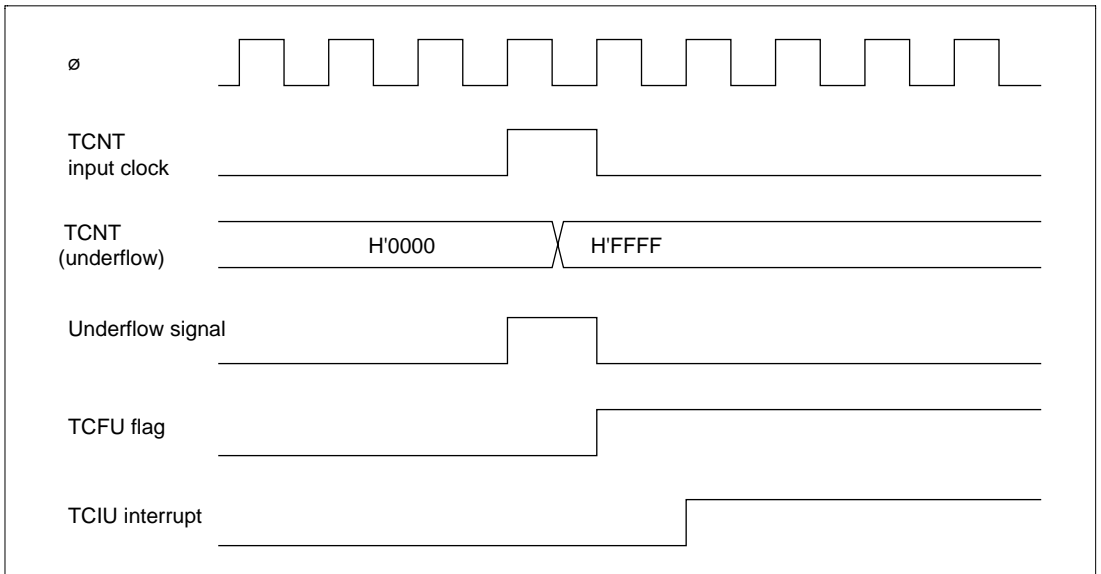

Figure 9-45 TCIU Interrupt Setting Timing

Status Flag Clearing Timing: After a status flag is read as 1 by the CPU, it is cleared by writing 0 to it. When the DTC is activated, the flag is cleared automatically. Figure 9-46 shows the timing for status flag clearing by the CPU, and figure 9-47 shows the timing for status flag clearing by the DTC.

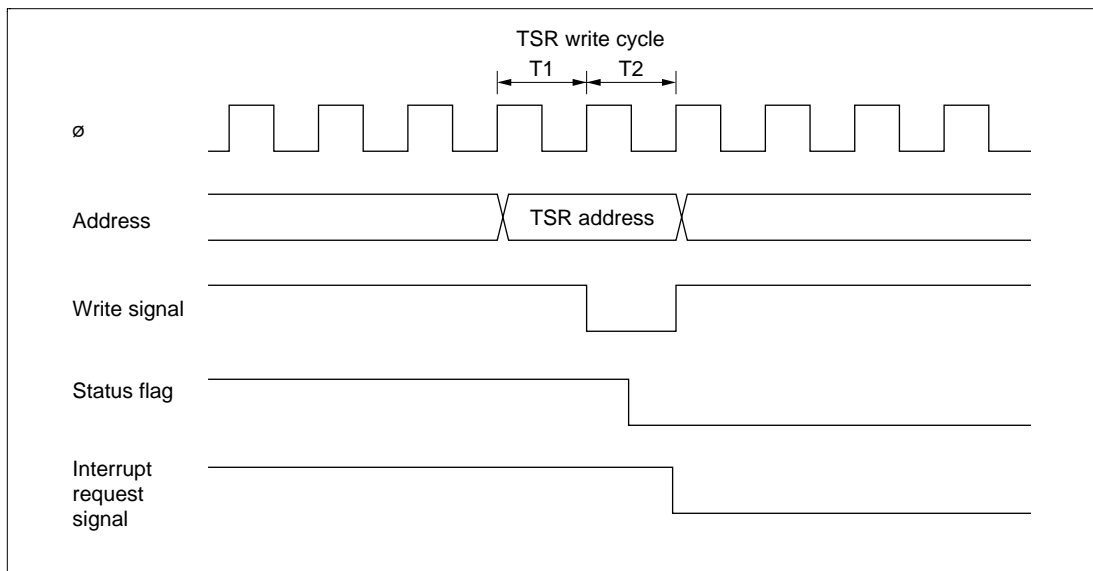

Figure 9-46 Timing for Status Flag Clearing by CPU

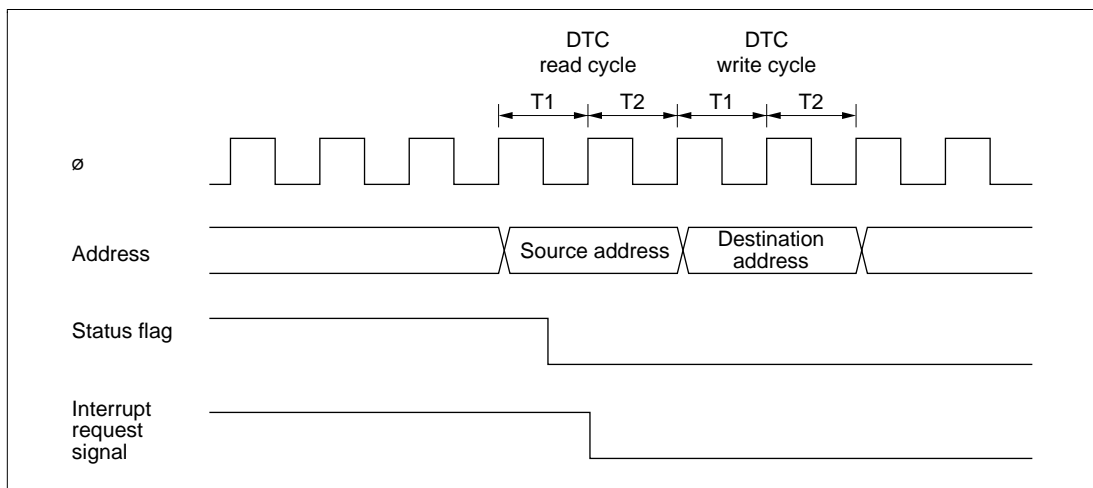

Figure 9-47 Timing for Status Flag Clearing by DTC Activation

9.7 Usage Notes

Note that the kinds of operation and contention described below occur during TPU operation.

Input Clock Restrictions: The input clock pulse width must be at least 1.5 states in the case of single-edge detection, and at least 2.5 states in the case of both-edge detection. The TPU will not operate properly with a narrower pulse width.

In phase counting mode, the phase difference and overlap between the two input clocks must be at least 1.5 states, and the pulse width must be at least 2.5 states. Figure 9-48 shows the input clock conditions in phase counting mode.

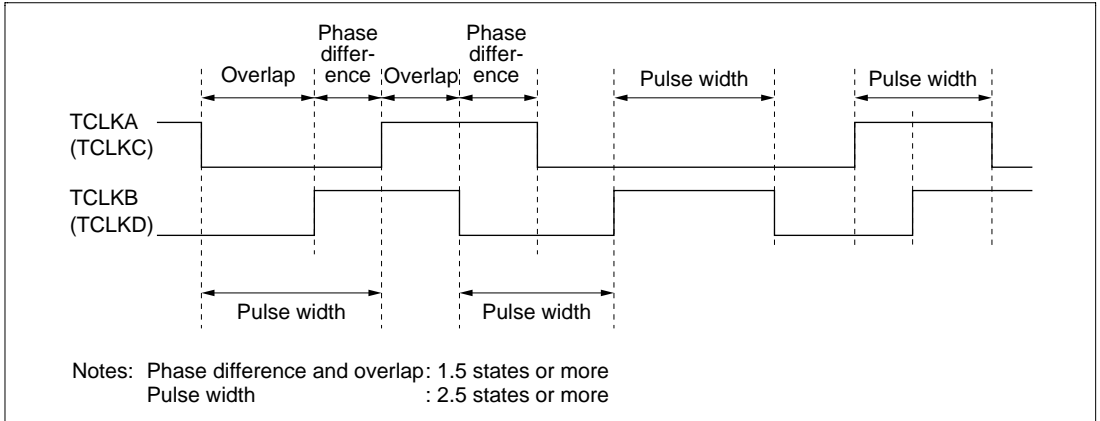

Figure 9-48 Phase Difference, Overlap, and Pulse Width in Phase Counting Mode

Caution on Period Setting: When counter clearing by compare match is set, TCNT is cleared in the final state in which it matches the TGR value (the point at which the count value matched by TCNT is updated). Consequently, the actual counter frequency is given by the following formula:

$$f = \frac{\phi}{(N + 1)}$$

Where f : Counter frequency
 ϕ : Operating frequency
 N : TGR set value

Contention between TCNT Write and Clear Operations: If the counter clear signal is generated in the T2 state of a TCNT write cycle, TCNT clearing takes precedence and the TCNT write is not performed.

Figure 9-49 shows the timing in this case.

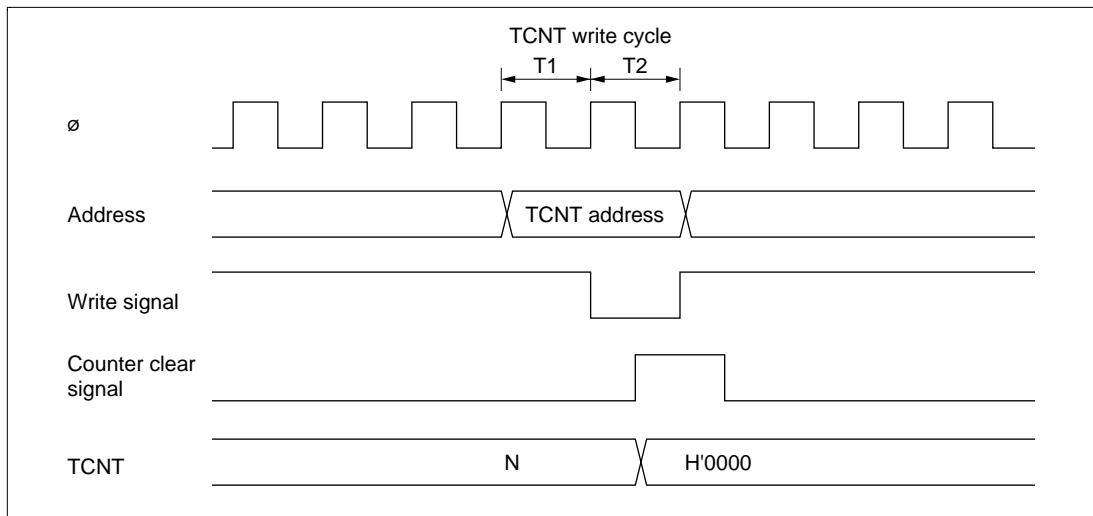

Figure 9-49 Contention between TCNT Write and Clear Operations

Contention between TCNT Write and Increment Operations: If incrementing occurs in the T2 state of a TCNT write cycle, the TCNT write takes precedence and TCNT is not incremented.

Figure 9-50 shows the timing in this case.

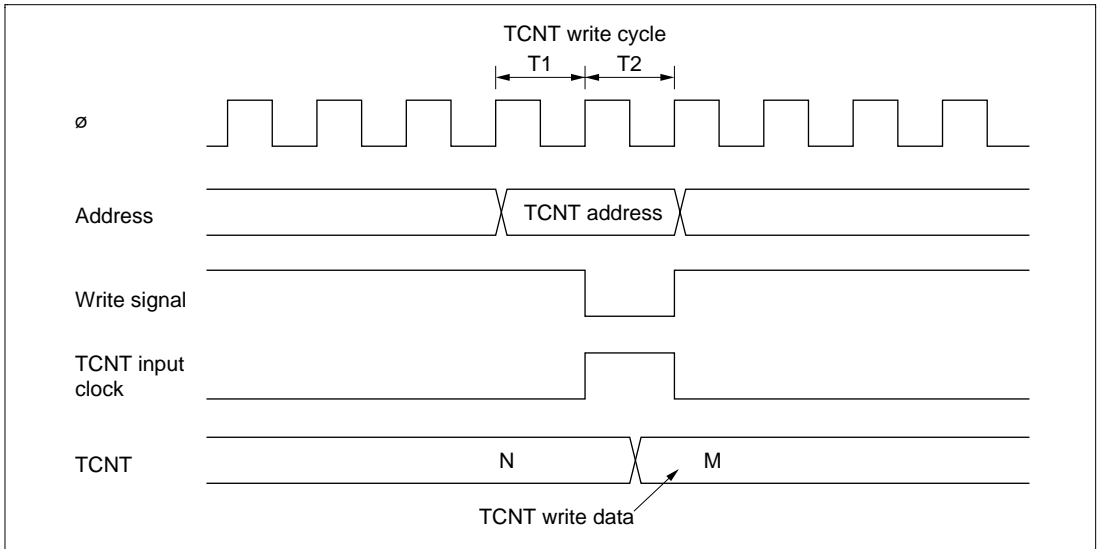

Figure 9-50 Contention between TCNT Write and Increment Operations

Contention between TGR Write and Compare Match: If a compare match occurs in the T2 state of a TGR write cycle, the TGR write takes precedence and the compare match signal is inhibited. A compare match does not occur even if the same value as before is written.

Figure 9-51 shows the timing in this case.

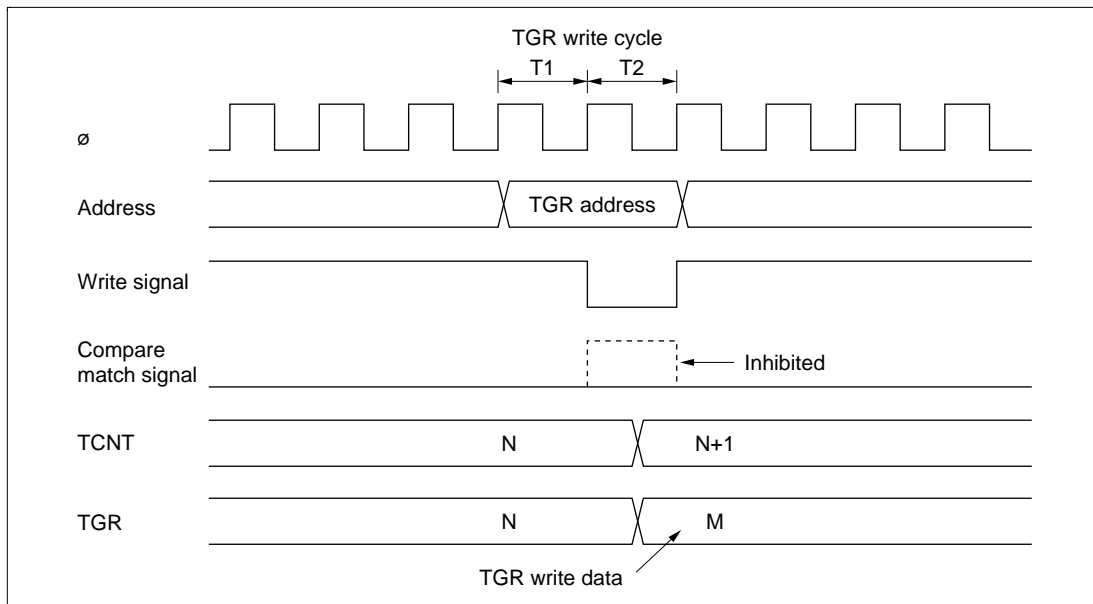

Figure 9-51 Contention between TGR Write and Compare Match

Contention between Buffer Register Write and Compare Match: If a compare match occurs in the T2 state of a TGR write cycle, the data transferred to TGR by the buffer operation will be the data prior to the write.

Figure 9-52 shows the timing in this case.

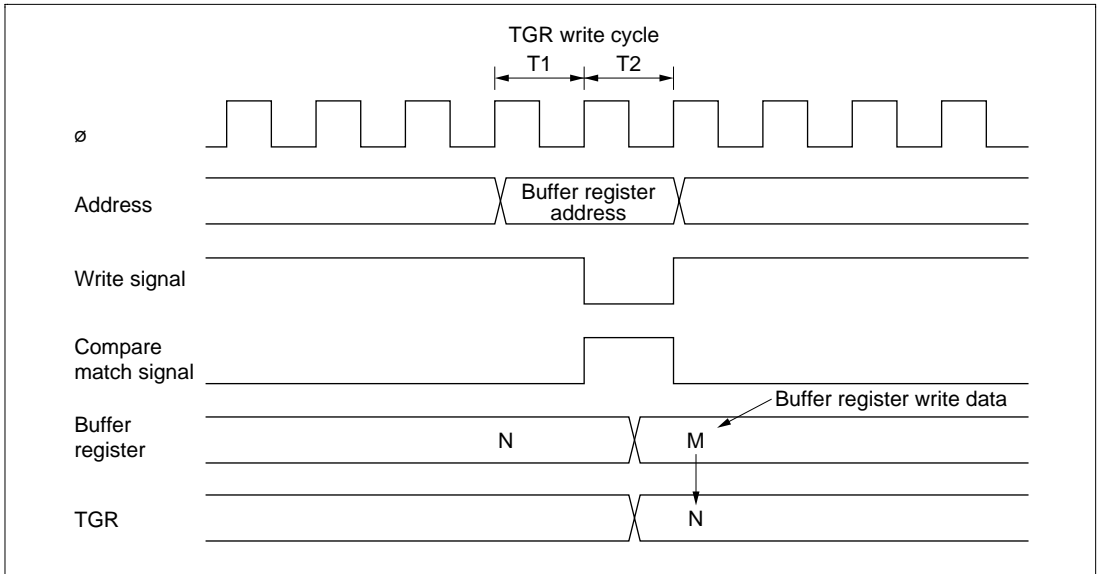

Figure 9-52 Contention between Buffer Register Write and Compare Match

Contention between TGR Read and Input Capture: If the input capture signal is generated in the T1 state of a TGR read cycle, the data that is read will be the data after input capture transfer.

Figure 9-53 shows the timing in this case.

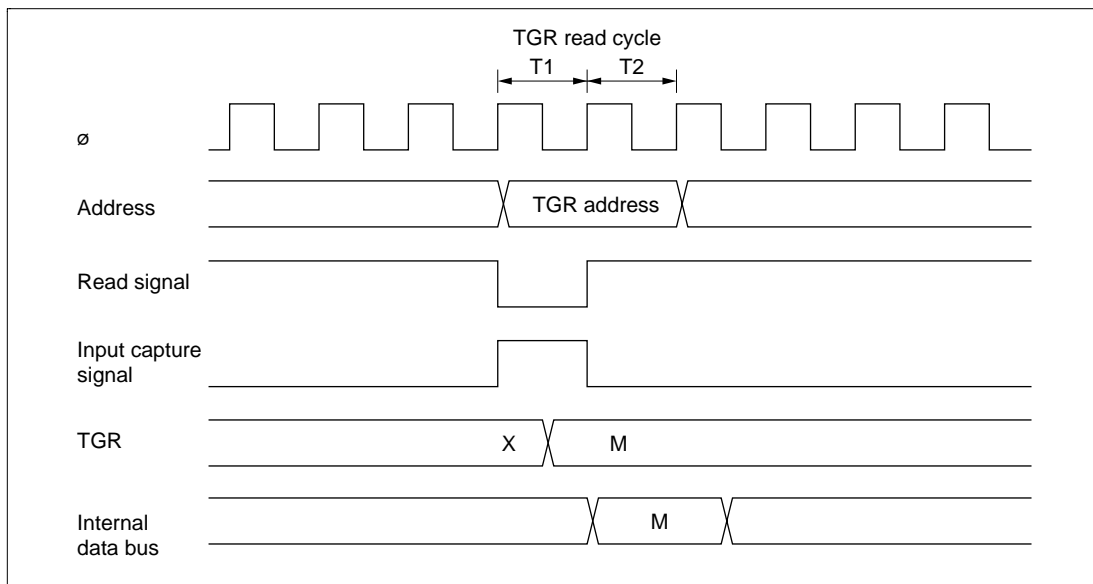

Figure 9-53 Contention between TGR Read and Input Capture

Contention between TGR Write and Input Capture: If the input capture signal is generated in the T2 state of a TGR write cycle, the input capture operation takes precedence and the write to TGR is not performed.

Figure 9-54 shows the timing in this case.

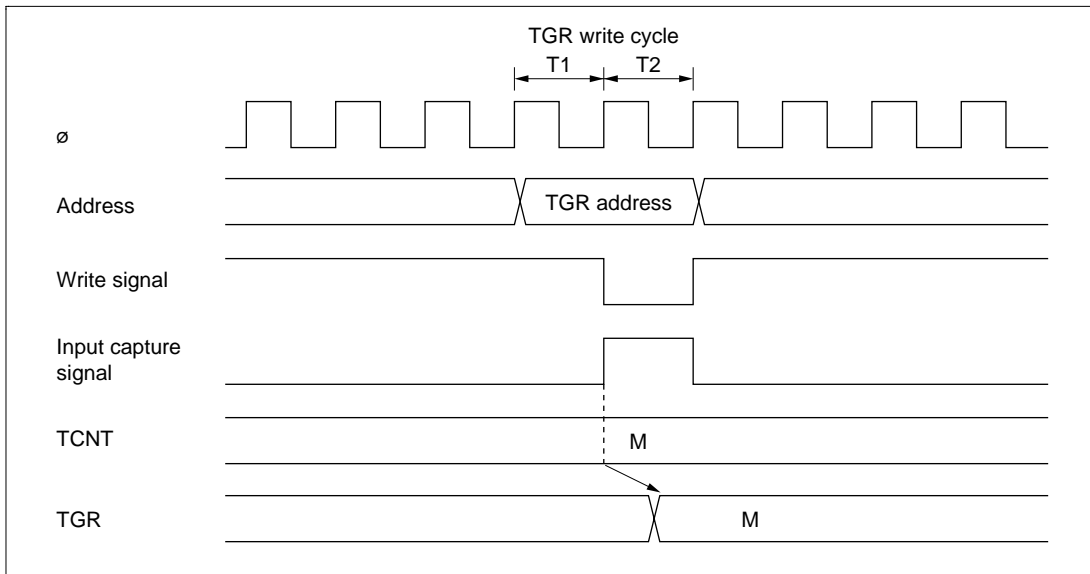

Figure 9-54 Contention between TGR Write and Input Capture

Contention between Buffer Register Write and Input Capture: If the input capture signal is generated in the T2 state of a buffer write cycle, the buffer operation takes precedence and the write to the buffer register is not performed.

Figure 9-55 shows the timing in this case.

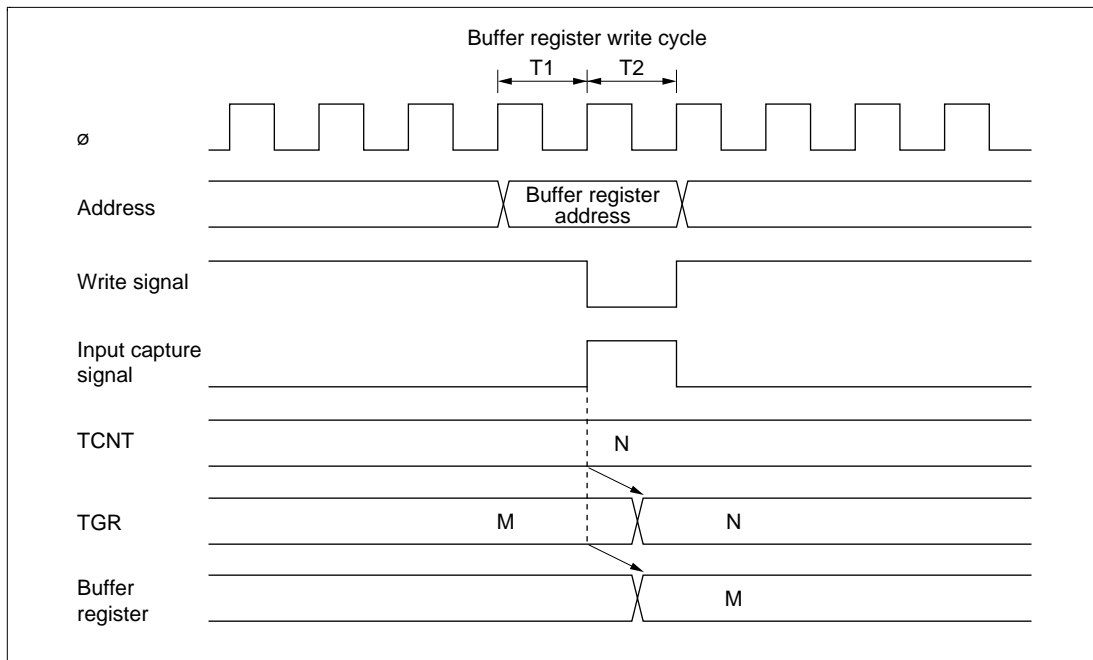

Figure 9-55 Contention between Buffer Register Write and Input Capture

Contention between Overflow/Underflow and Counter Clearing: If overflow/underflow and counter clearing occur simultaneously, the TCFV/TCFU flag in TSR is not set and TCNT clearing takes precedence.

Figure 9-56 shows the operation timing when a TGR compare match is specified as the clearing source, and H'FFFF is set in TGR.

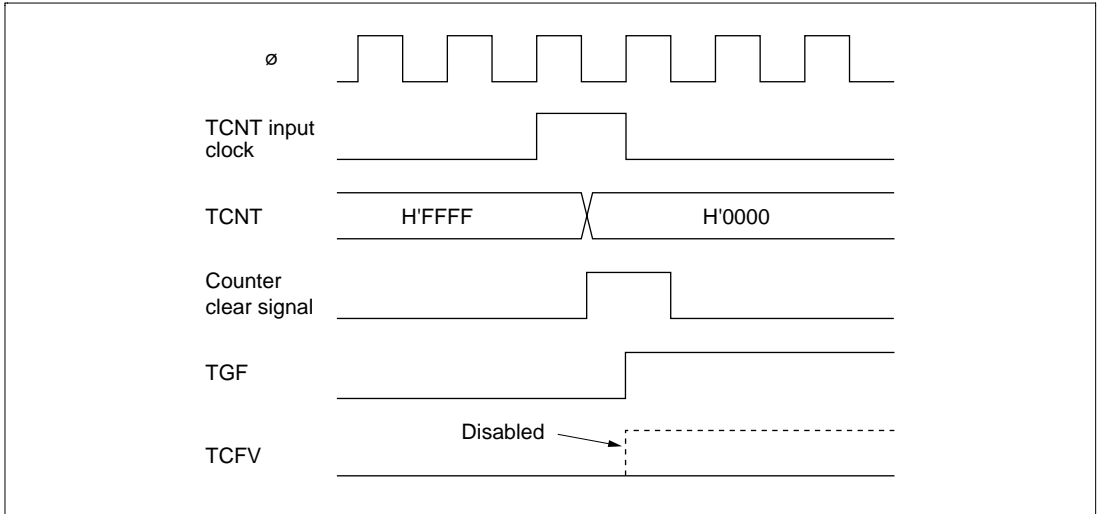

Figure 9-56 Contention between Overflow and Counter Clearing

Contention between TCNT Write and Overflow/Underflow: If there is an up-count or down-count in the T2 state of a TCNT write cycle, and overflow/underflow occurs, the TCNT write takes precedence and the TCFV/TCFU flag in TSR is not set .

Figure 9-57 shows the operation timing when there is contention between TCNT write and overflow.

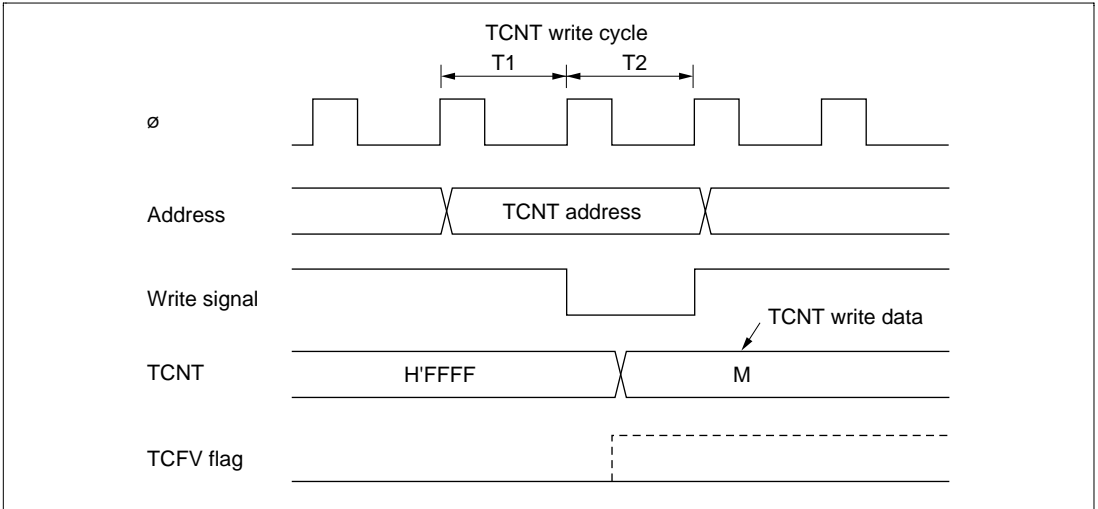

Figure 9-57 Contention between TCNT Write and Overflow

Multiplexing of I/O Pins: In the H8S/2355 Series, the TCLKA input pin is multiplexed with the TIOCC0 I/O pin, the TCLKB input pin with the TIOCD0 I/O pin, the TCLKC input pin with the TIOCB1 I/O pin, and the TCLKD input pin with the TIOCB2 I/O pin. When an external clock is input, compare match output should not be performed from a multiplexed pin.

Interrupts and Module Stop Mode: If module stop mode is entered when an interrupt has been requested, it will not be possible to clear the CPU interrupt source or DTC activation source. Interrupts should therefore be disabled before entering module stop mode.

Section 10 8-Bit Timers

10.1 Overview

The H8S/2355 Series includes an 8-bit timer module with two channels (TMR0 and TMR1). Each channel has an 8-bit counter (TCNT) and two time constant registers (TCORA and TCORB) that are constantly compared with the TCNT value to detect compare match events. The 8-bit timer module can thus be used for a variety of functions, including pulse output with an arbitrary duty cycle.

10.1.1 Features

The features of the 8-bit timer module are listed below.

- Selection of four clock sources
The counters can be driven by one of three internal clock signals ($\phi/8$, $\phi/64$, or $\phi/8192$) or an external clock input (enabling use as an external event counter).
- Selection of three ways to clear the counters
The counters can be cleared on compare match A or B, or by an external reset signal.
- Timer output control by a combination of two compare match signals
The timer output signal in each channel is controlled by a combination of two independent compare match signals, enabling the timer to generate output waveforms with an arbitrary duty cycle or PWM output.
- Provision for cascading of two channels
 - Operation as a 16-bit timer is possible, using channel 0 for the upper 8 bits and channel 1 for the lower 8 bits (16-bit count mode).
 - Channel 1 can be used to count channel 0 compare matches (compare match count mode).
- Three independent interrupts
Compare match A and B and overflow interrupts can be requested independently.
- A/D converter conversion start trigger can be generated
Channel 0 compare match A signal can be used as an A/D converter conversion start trigger.
- Module stop mode can be set
 - As the initial setting, 8-bit timer operation is halted. Register access is enabled by exiting module stop mode.

10.1.2 Block Diagram

Figure 10-1 shows a block diagram of the 8-bit timer module.

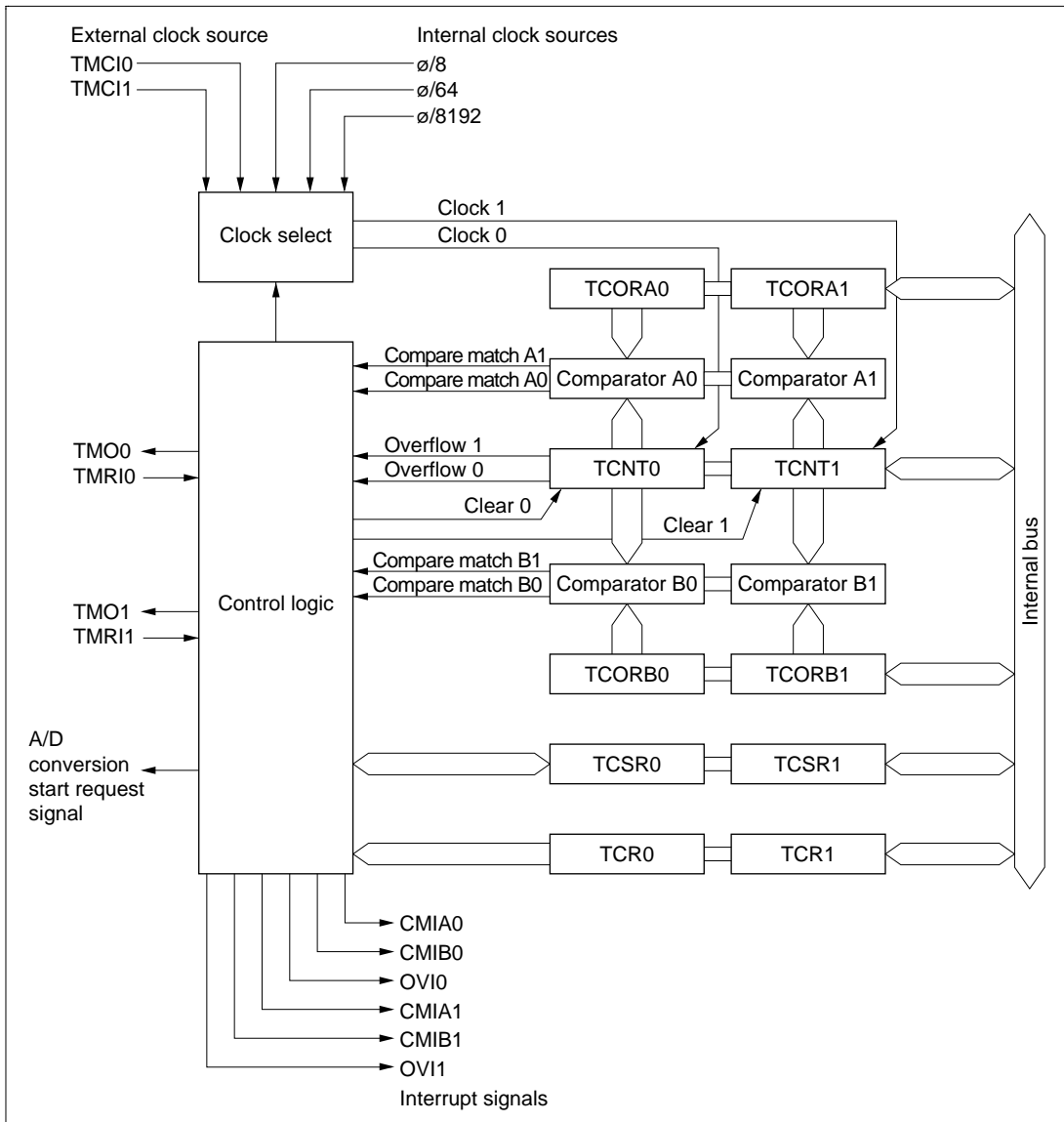

Figure 10-1 Block Diagram of 8-Bit Timer

10.1.3 Pin Configuration

Table 10-1 summarizes the input and output pins of the 8-bit timer.

Table 10-1 Input and Output Pins of 8-Bit Timer

Channel	Name	Symbol	I/O	Function
0	Timer output pin 0	TMO0	Output	Outputs at compare match
	Timer clock input pin 0	TMCI0	Input	Inputs external clock for counter
	Timer reset input pin 0	TMRI0	Input	Inputs external reset to counter
1	Timer output pin 1	TMO1	Output	Outputs at compare match
	Timer clock input pin 1	TMCI1	Input	Inputs external clock for counter
	Timer reset input pin 1	TMRI1	Input	Inputs external reset to counter

10.1.4 Register Configuration

Table 10-2 summarizes the registers of the 8-bit timer module.

Table 10-2 8-Bit Timer Registers

Channel	Name	Abbreviation	R/W	Initial value	Address* ¹
0	Timer control register 0	TCR0	R/W	H'00	H'FFB0
	Timer control/status register 0	TCSR0	R/(W)* ²	H'00	H'FFB2
	Time constant register A0	TCORA0	R/W	H'FF	H'FFB4
	Time constant register B0	TCORB0	R/W	H'FF	H'FFB6
	Timer counter 0	TCNT0	R/W	H'00	H'FFB8
1	Timer control register 1	TCR1	R/W	H'00	H'FFB1
	Timer control/status register 1	TCSR1	R/(W)* ²	H'10	H'FFB3
	Time constant register A1	TCORA1	R/W	H'FF	H'FFB5
	Time constant register B1	TCORB1	R/W	H'FF	H'FFB7
	Timer counter 1	TCNT1	R/W	H'00	H'FFB9
All	Module stop control register	MSTPCR	R/W	H'3FFF	H'FF3C

Notes: 1. Lower 16 bits of the address

2. Only 0 can be written to bits 7 to 5, to clear these flags.

Each pair of registers for channel 0 and channel 1 is a 16-bit register with the upper 8 bits for channel 0 and the lower 8 bits for channel 1, so they can be accessed together by word transfer instruction.

10.2 Register Descriptions

10.2.1 Timer Counters 0 and 1 (TCNT0, TCNT1)



TCNT0 and TCNT1 are 8-bit readable/writable up-counters that increment on pulses generated from an internal or external clock source. This clock source is selected by clock select bits CKS2 to CKS0 of TCR. The CPU can read or write to TCNT0 and TCNT1 at all times.

TCNT0 and TCNT1 comprise a single 16-bit register, so they can be accessed together by word transfer instruction.

TCNT0 and TCNT1 can be cleared by an external reset input or by a compare match signal. Which signal is to be used for clearing is selected by clock clear bits CCLR1 and CCLR0 of TCR.

When a timer counter overflows from H'FF to H'00, OVF in TCSR is set to 1.

TCNT0 and TCNT1 are each initialized to H'00 by a reset and in hardware standby mode.

10.2.2 Time Constant Registers A0 and A1 (TCORA0, TCORA1)

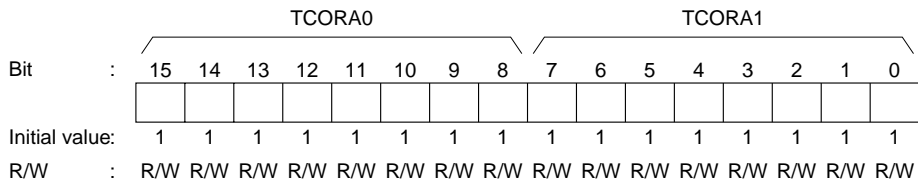

TCORA0 and TCORA1 are 8-bit readable/writable registers. TCORA0 and TCORA1 comprise a single 16-bit register so they can be accessed together by word transfer instruction.

TCORA is continually compared with the value in TCNT. When a match is detected, the corresponding CMFA flag of TCSR is set. Note, however, that comparison is disabled during the T2 state of a TCOR write cycle.

The timer output can be freely controlled by these compare match signals and the settings of bits OS1 and OS0 of TCSR.

TCORA0 and TCORA1 are each initialized to H'FF by a reset and in hardware standby mode.

10.2.3 Time Constant Registers B0 and B1 (TCORB0, TCORB1)

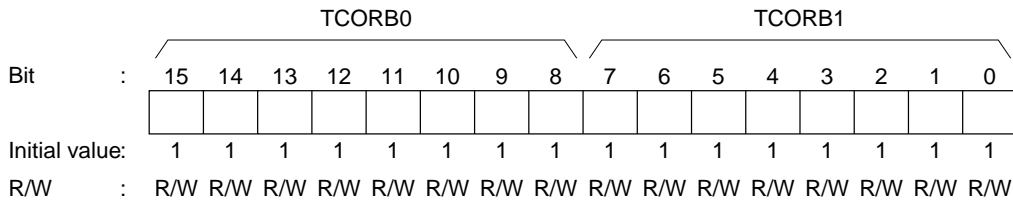

TCORB0 and TCORB1 are 8-bit readable/writable registers. TCORB0 and TCORB1 comprise a single 16-bit register so they can be accessed together by word transfer instruction.

TCORB is continually compared with the value in TCNT. When a match is detected, the corresponding CMFB flag of TCSR is set. Note, however, that comparison is disabled during the T2 state of a TCOR write cycle.

The timer output can be freely controlled by these compare match signals and the settings of output select bits OS3 and OS2 of TCSR.

TCORB0 and TCORB1 are each initialized to H'FF by a reset and in hardware standby mode.

10.2.4 Time Control Registers 0 and 1 (TCR0, TCR1)

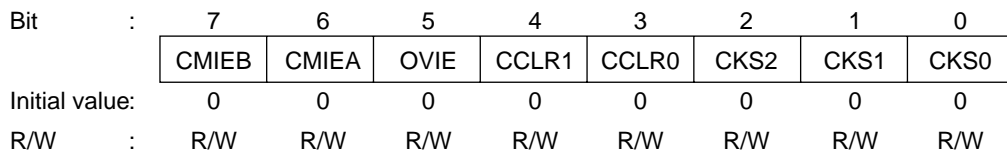

TCR0 and TCR1 are 8-bit readable/writable registers that select the clock source and the time at which TCNT is cleared, and enable interrupts.

TCR0 and TCR1 are each initialized to H'00 by a reset and in hardware standby mode.

For details of this timing, see section 10.3, Operation.

Bit 7—Compare Match Interrupt Enable B (CMIEB): Selects whether CMFB interrupt requests (CMIB) are enabled or disabled when the CMFB flag of TCSR is set to 1.

Bit 7

CMIEB	Description
0	CMFB interrupt requests (CMIB) are disabled (Initial value)
1	CMFB interrupt requests (CMIB) are enabled

Bit 6—Compare Match Interrupt Enable A (CMIEA): Selects whether CMFA interrupt requests (CMIA) are enabled or disabled when the CMFA flag of TCSR is set to 1.

Bit 6

CMIEA	Description
0	CMFA interrupt requests (CMIA) are disabled (Initial value)
1	CMFA interrupt requests (CMIA) are enabled

Bit 5—Timer Overflow Interrupt Enable (OVIE): Selects whether OVF interrupt requests (OVI) are enabled or disabled when the OVF flag of TCSR is set to 1.

Bit 5

OVIE	Description
0	OVF interrupt requests (OVI) are disabled (Initial value)
1	OVF interrupt requests (OVI) are enabled

Bits 4 and 3—Counter Clear 1 and 0 (CCLR1 and CCLR0): These bits select the method by which TCNT is cleared: by compare match A or B, or by an external reset input.

Bit 4

Bit 3

CCLR1	CCLR0	Description
0	0	Clear is disabled (Initial value)
	1	Clear by compare match A
1	0	Clear by compare match B
	1	Clear by rising edge of external reset input

Bits 2 to 0—Clock Select 2 to 0 (CKS2 to CKS0): These bits select whether the clock input to TCNT is an internal or external clock.

Three internal clocks can be selected, all divided from the system clock (ϕ): $\phi/8$, $\phi/64$, and $\phi/8192$. The falling edge of the selected internal clock triggers the count.

When use of an external clock is selected, three types of count can be selected: at the rising edge, the falling edge, and both rising and falling edges.

Some functions differ between channel 0 and channel 1.

Bit 2	Bit 1	Bit 0	Description
CKS2	CKS1	CKS0	
0	0	0	Clock input disabled (Initial value)
		1	Internal clock, counted at falling edge of $\phi/8$
	1	0	Internal clock, counted at falling edge of $\phi/64$
		1	Internal clock, counted at falling edge of $\phi/8192$
1	0	0	For channel 0: count at TCNT1 overflow signal* For channel 1: count at TCNT0 compare match A*
		1	External clock, counted at rising edge
	1	0	External clock, counted at falling edge
		1	External clock, counted at both rising and falling edges

Note: * If the count input of channel 0 is the TCNT1 overflow signal and that of channel 1 is the TCNT0 compare match signal, no incrementing clock is generated. Do not use this setting.

10.2.5 Timer Control/Status Registers 0 and 1 (TCSR0, TCSR1)

TCSR0

Bit	:	7	6	5	4	3	2	1	0
		CMFB	CMFA	OVF	ADTE	OS3	OS2	OS1	OS0
Initial value:		0	0	0	0	0	0	0	0
R/W	:	R/(W)*	R/(W)*	R/(W)*	R/W	R/W	R/W	R/W	R/W

TCSR1

Bit	:	7	6	5	4	3	2	1	0
		CMFB	CMFA	OVF	—	OS3	OS2	OS1	OS0
Initial value:		0	0	0	1	0	0	0	0
R/W	:	R/(W)*	R/(W)*	R/(W)*	—	R/W	R/W	R/W	R/W

Note: * Only 0 can be written to bits 7 to 5, to clear these flags.

TCSR0 and TCSR1 are 8-bit registers that display compare match and overflow statuses, and control compare match output.

TCSR0 is initialized to H'00, and TCSR1 to H'10, by a reset and in hardware standby mode.

Bit 7—Compare Match Flag B (CMFB): Status flag indicating whether the values of TCNT and TCORB match.

Bit 7

CMFB	Description
0	[Clearing conditions] (Initial value) <ul style="list-style-type: none"> • Cleared by reading CMFB when CMFB = 1, then writing 0 to CMFB • When DTC is activated by CMIB interrupt while DISEL bit of MRB in DTC is 0
1	[Setting condition] Set when TCNT matches TCORB

Bit 6—Compare Match Flag A (CMFA): Status flag indicating whether the values of TCNT and TCORA match.

Bit 6

CMFA	Description
0	[Clearing conditions] (Initial value) <ul style="list-style-type: none"> • Cleared by reading CMFA when CMFA = 1, then writing 0 to CMFA • When DTC is activated by CMIA interrupt while DISEL bit of MRB in DTC is 0
1	[Setting condition] Set when TCNT matches TCORA

Bit 5—Timer Overflow Flag (OVF): Status flag indicating that TCNT has overflowed (changed from H'FF to H'00).

Bit 5

OVF	Description
0	[Clearing condition] (Initial value) Cleared by reading OVF when OVF = 1, then writing 0 to OVF
1	[Setting condition] Set when TCNT overflows from H'FF to H'00

Bit 4—A/D Trigger Enable (ADTE) (TCSR0 Only): Selects enabling or disabling of A/D converter start requests by compare-match A.

In TCSR1, this bit is reserved: it is always read as 1 and cannot be modified.

Bit 4

ADTE	Description
0	A/D converter start requests by compare match A are disabled (Initial value)
1	A/D converter start requests by compare match A are enabled

Bits 3 to 0—Output Select 3 to 0 (OS3 to OS0): These bits specify how the timer output level is to be changed by a compare match of TCOR and TCNT.

Bits OS3 and OS2 select the effect of compare match B on the output level, bits OS1 and OS0 select the effect of compare match A on the output level, and both of them can be controlled independently.

Note, however, that priorities are set such that: toggle output > 1 output > 0 output. If compare matches occur simultaneously, the output changes according to the compare match with the higher priority.

Timer output is disabled when bits OS3 to OS0 are all 0.

After a reset, the timer output is 0 until the first compare match event occurs.

Bit 3	Bit 2	Description
0	0	No change when compare match B occurs (Initial value)
	1	0 is output when compare match B occurs
1	0	1 is output when compare match B occurs
	1	Output is inverted when compare match B occurs (toggle output)

Bit 1	Bit 0	Description
0	0	No change when compare match A occurs (Initial value)
	1	0 is output when compare match A occurs
1	0	1 is output when compare match A occurs
	1	Output is inverted when compare match A occurs (toggle output)

10.2.6 Module Stop Control Register (MSTPCR)

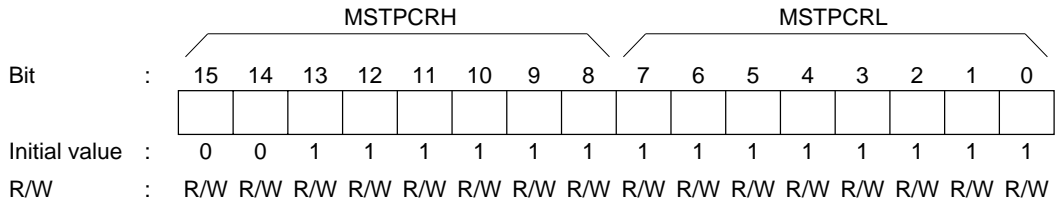

MSTPCR is a 16-bit readable/writable register that performs module stop mode control.

When the MSTP12 bit in MSTPCR is set to 1, the 8-bit timer operation stops at the end of the bus cycle and a transition is made to module stop mode. Registers cannot be read or written to in module stop mode. For details, see section 19.5, Module Stop Mode.

MSTPCR is initialized to H'3FFF by a reset and in hardware standby mode. It is not initialized in software standby mode.

Bit 12—Module Stop (MSTP12): Specifies the 8-bit timer stop mode.

Bit 12

MSTP12	Description
0	8-bit timer module stop mode cleared
1	8-bit timer module stop mode set (Initial value)

10.3 Operation

10.3.1 TCNT Incrementation Timing

TCNT is incremented by input clock pulses (either internal or external).

Internal Clock: Three different internal clock signals ($\phi/8$, $\phi/64$, or $\phi/8192$) divided from the system clock (ϕ) can be selected, by setting bits CKS2 to CKS0 in TCR. Figure 10-2 shows the count timing.

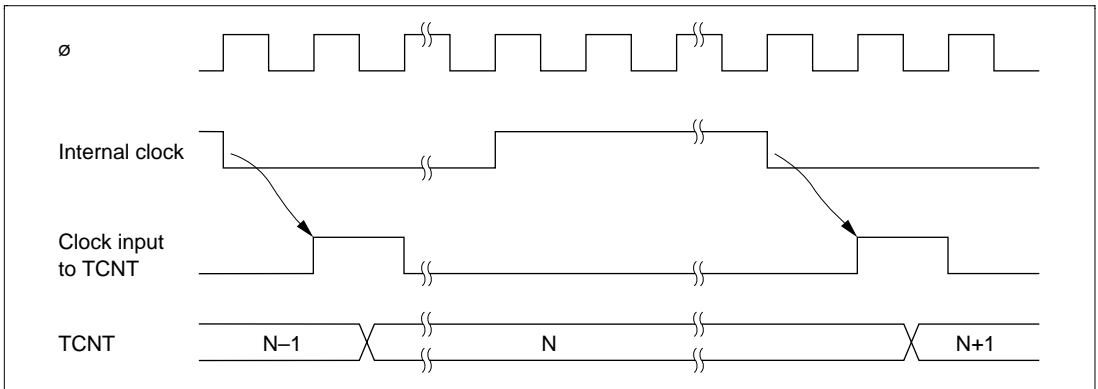

Figure 10-2 Count Timing for Internal Clock Input

External Clock: Three incrementation methods can be selected by setting bits CKS2 to CKS0 in TCR: at the rising edge, the falling edge, and both rising and falling edges.

Note that the external clock pulse width must be at least 1.5 states for incrementation at a single edge, and at least 2.5 states for incrementation at both edges. The counter will not increment correctly if the pulse width is less than these values.

Figure 10-3 shows the timing of incrementation at both edges of an external clock signal.

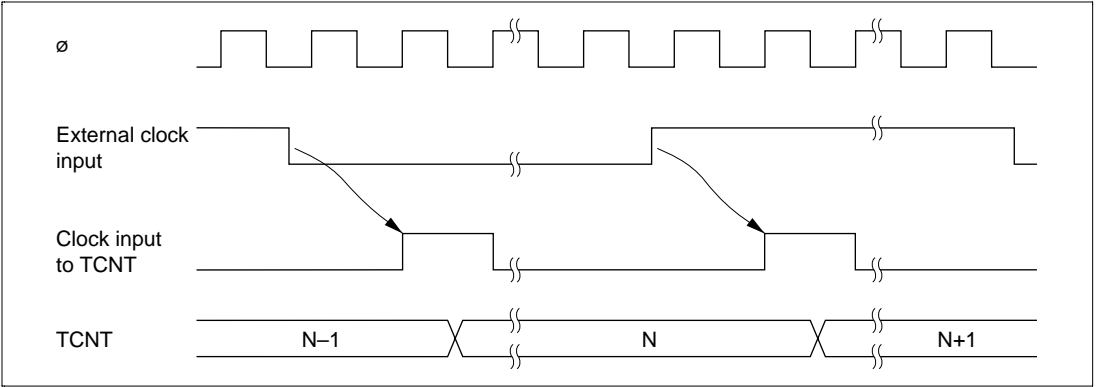

Figure 10-3 Count Timing for External Clock Input

10.3.2 Compare Match Timing

Setting of Compare Match Flags A and B (CMFA, CMFB): The CMFA and CMFB flags in TCSR are set to 1 by a compare match signal generated when the TCOR and TCNT values match. The compare match signal is generated at the last state in which the match is true, just before the timer counter is updated.

Therefore, when TCOR and TCNT match, the compare match signal is not generated until the next incrementation clock input. Figure 10-4 shows this timing.

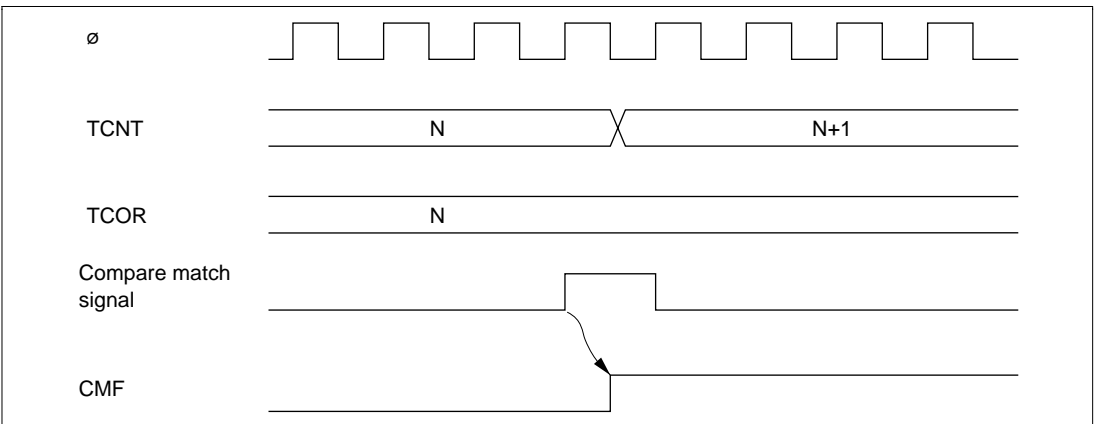

Figure 10-4 Timing of CMF Setting

Timer Output Timing: When compare match A or B occurs, the timer output changes a specified by bits OS3 to OS0 in TCSR. Depending on these bits, the output can remain the same, change to 0, change to 1, or toggle.

Figure 10-5 shows the timing when the output is set to toggle at compare match A.

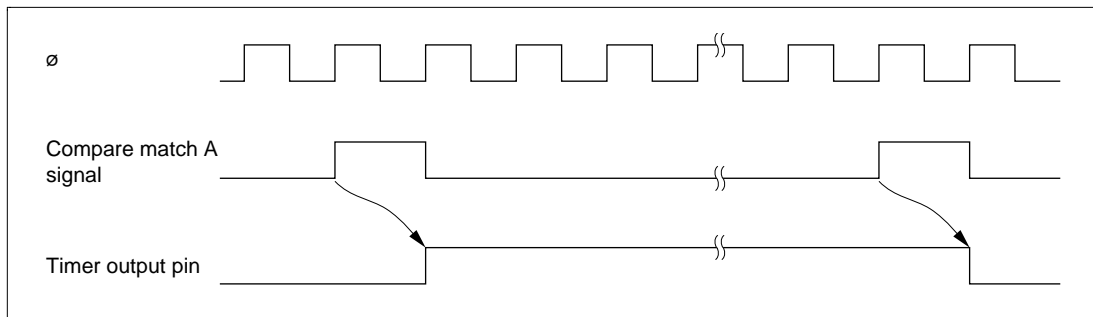

Figure 10-5 Timing of Timer Output

Timing of Compare Match Clear: The timer counter is cleared when compare match A or B occurs, depending on the setting of the CCLR1 and CCLR0 bits in TCR. Figure 10-6 shows the timing of this operation.

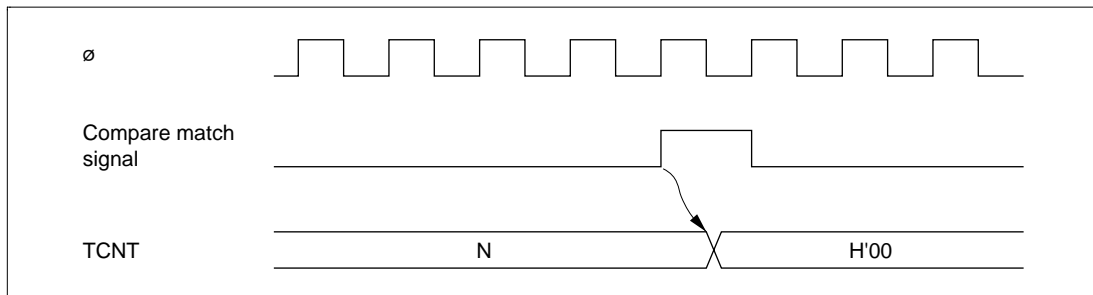

Figure 10-6 Timing of Compare Match Clear

10.3.3 Timing of External RESET on TCNT

TCNT is cleared at the rising edge of an external reset input, depending on the settings of the CCLR1 and CCLR0 bits in TCR. The clear pulse width must be at least 1.5 states. Figure 10-7 shows the timing of this operation.

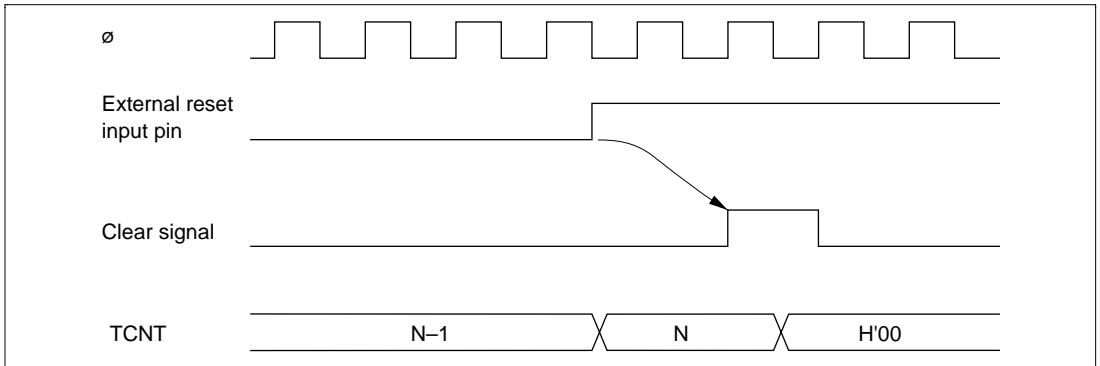

Figure 10-7 Timing of External Reset

10.3.4 Timing of Overflow Flag (OVF) Setting

The OVF in TCSR is set to 1 when the timer count overflows (changes from H'FF to H'00). Figure 10-8 shows the timing of this operation.

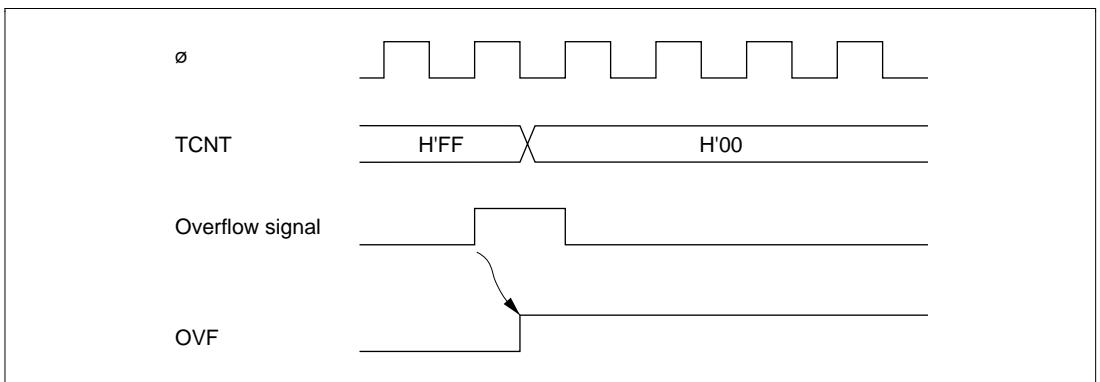

Figure 10-8 Timing of OVF Setting

10.3.5 Operation with Cascaded Connection

If bits CKS2 to CKS0 in either TCR0 or TCR1 are set to B'100, the 8-bit timers of the two channels are cascaded. With this configuration, a single 16-bit timer could be used (16-bit timer mode) or compare matches of the 8-bit channel 0 could be counted by the timer of channel 1 (compare match counter mode). In this case, the timer operates as below.

16-Bit Counter Mode: When bits CKS2 to CKS0 in TCR0 are set to B'100, the timer functions as a single 16-bit timer with channel 0 occupying the upper 8 bits and channel 1 occupying the lower 8 bits.

- Setting of compare match flags
 - The CMF flag in TCSR0 is set to 1 when a 16-bit compare match event occurs.
 - The CMF flag in TCSR1 is set to 1 when a lower 8-bit compare match event occurs.
- Counter clear specification
 - If the CCLR1 and CCLR0 bits in TCR0 have been set for counter clear at compare match, the 16-bit counter (TCNT0 and TCNT1 together) is cleared when a 16-bit compare match event occurs. The 16-bit counter (TCNT0 and TCNT1 together) is cleared even if counter clear by the TMRI0 pin has also been set.
 - The settings of the CCLR1 and CCLR0 bits in TCR1 are ignored. The lower 8 bits cannot be cleared independently.
- Pin output
 - Control of output from the TMO0 pin by bits OS3 to OS0 in TCSR0 is in accordance with the 16-bit compare match conditions.
 - Control of output from the TMO1 pin by bits OS3 to OS0 in TCSR1 is in accordance with the lower 8-bit compare match conditions.

Compare Match Counter Mode: When bits CKS2 to CKS0 in TCR1 are B'100, TCNT1 counts compare match A's for channel 0.

Channels 0 and 1 are controlled independently. Conditions such as setting of the CMF flag, generation of interrupts, output from the TMO pin, and counter clear are in accordance with the settings for each channel.

Note on Usage: If the 16-bit counter mode and compare match counter mode are set simultaneously, the input clock pulses for TCNT0 and TCNT1 are not generated and thus the counters will stop operating. Software should therefore avoid using both these modes.

10.4 Interrupts

10.4.1 Interrupt Sources and DTC Activation

There are three 8-bit timer interrupt sources: CMIA, CMIB, and OVI. Their relative priorities are shown in Table 10-3. Each interrupt source is set as enabled or disabled by the corresponding interrupt enable bit in TCR, and independent interrupt requests are sent for each to the interrupt controller. It is also possible to activate the DTC by means of CMIA and CMIB interrupts.

Table 10-3 8-Bit Timer Interrupt Sources

Interrupt Source	Description	DTC Activation	Priority
CMIA0	Interrupt by CMFA	Possible	High
CMIB0	Interrupt by CMFB	Possible	
OVI0	Interrupt by OVF	Not possible	
CMIA1	Interrupt by CMFA	Possible	
CMIB1	Interrupt by CMFB	Possible	
OVI1	Interrupt by OVF	Not possible	

Note: This table shows the initial state immediately after a reset. The relative channel priorities can be changed by the interrupt controller.

10.4.2 A/D Converter Activation

The A/D converter can be activated only by channel 0 compare match A.

If the ADTE bit in TCSR0 is set to 1 when the CMFA flag is set to 1 by the occurrence of channel 0 compare match A, a request to start A/D conversion is sent to the A/D converter. If the 8-bit timer conversion start trigger has been selected on the A/D converter side at this time, A/D conversion is started.

10.5 Sample Application

In the example below, the 8-bit timer is used to generate a pulse output with a selected duty cycle, as shown in figure 10-9. The control bits are set as follows:

- [1] In TCR, bit CCLR1 is cleared to 0 and bit CCLR0 is set to 1 so that the timer counter is cleared when its value matches the constant in TCORA.
- [2] In TCSR, bits OS3 to OS0 are set to B'0110, causing the output to change to 1 at a TCORA compare match and to 0 at a TCORB compare match.

With these settings, the 8-bit timer provides output of pulses at a rate determined by TCORA with a pulse width determined by TCORB. No software intervention is required.

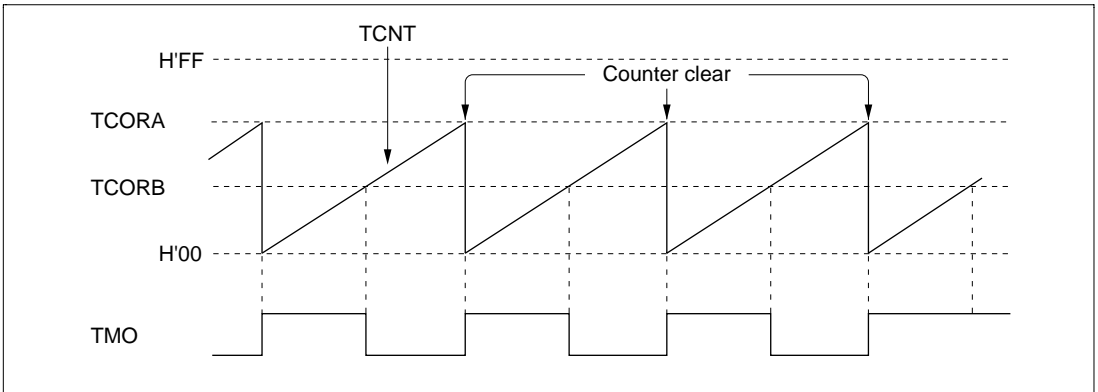

Figure 10-9 Example of Pulse Output

10.6 Usage Notes

Application programmers should note that the following kinds of contention can occur in the 8-bit timer.

10.6.1 Contention between TCNT Write and Clear

If a timer counter clock pulse is generated during the T_2 state of a TCNT write cycle, the clear takes priority, so that the counter is cleared and the write is not performed.

Figure 10-10 shows this operation.

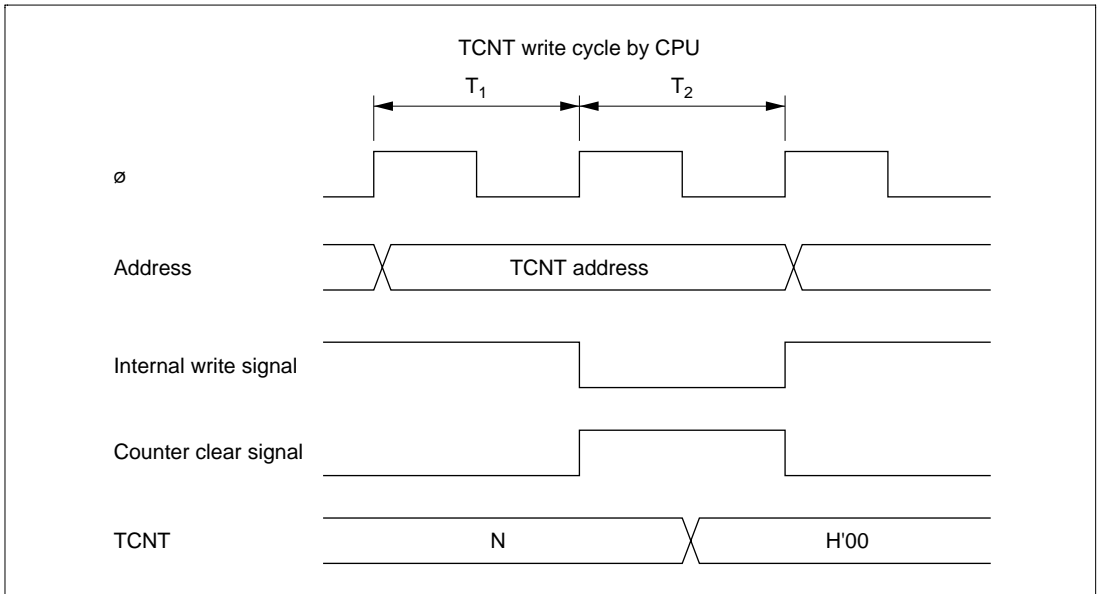

Figure 10-10 Contention between TCNT Write and Clear

10.6.2 Contention between TCNT Write and Increment

If a timer counter clock pulse is generated during the T_2 state of a TCNT write cycle, the write takes priority and the counter is not incremented.

Figure 10-11 shows this operation.

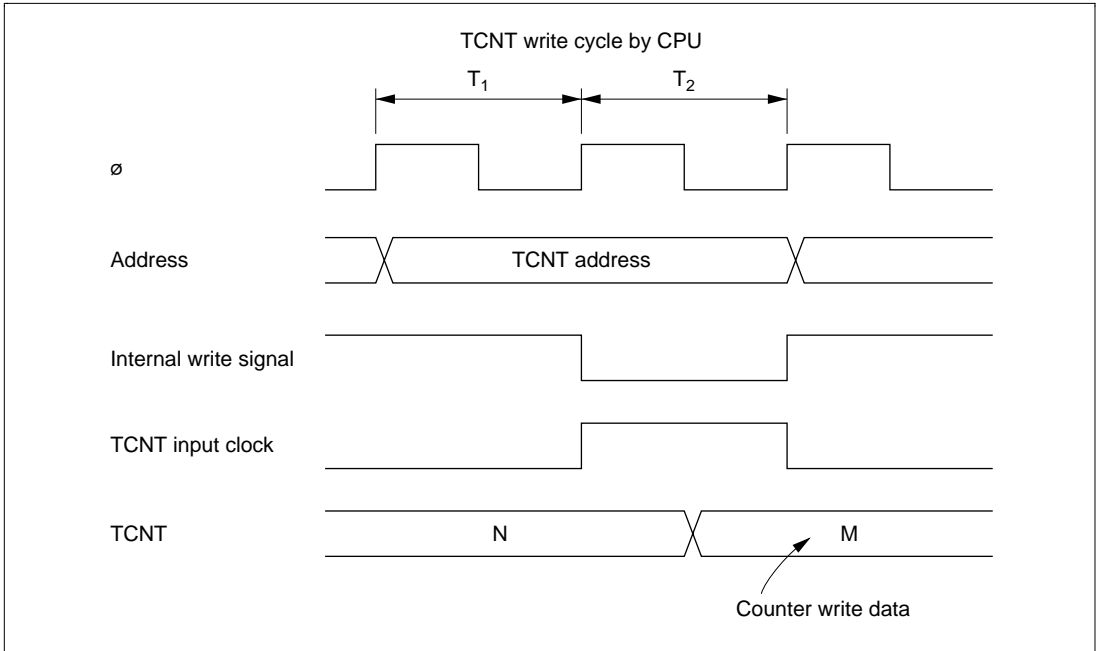

Figure 10-11 Contention between TCNT Write and Increment

10.6.3 Contention between TCOR Write and Compare Match

During the T_2 state of a TCOR write cycle, the TCOR write has priority and the compare match signal is disabled even if a compare match event occurs.

Figure 10-12 shows this operation.

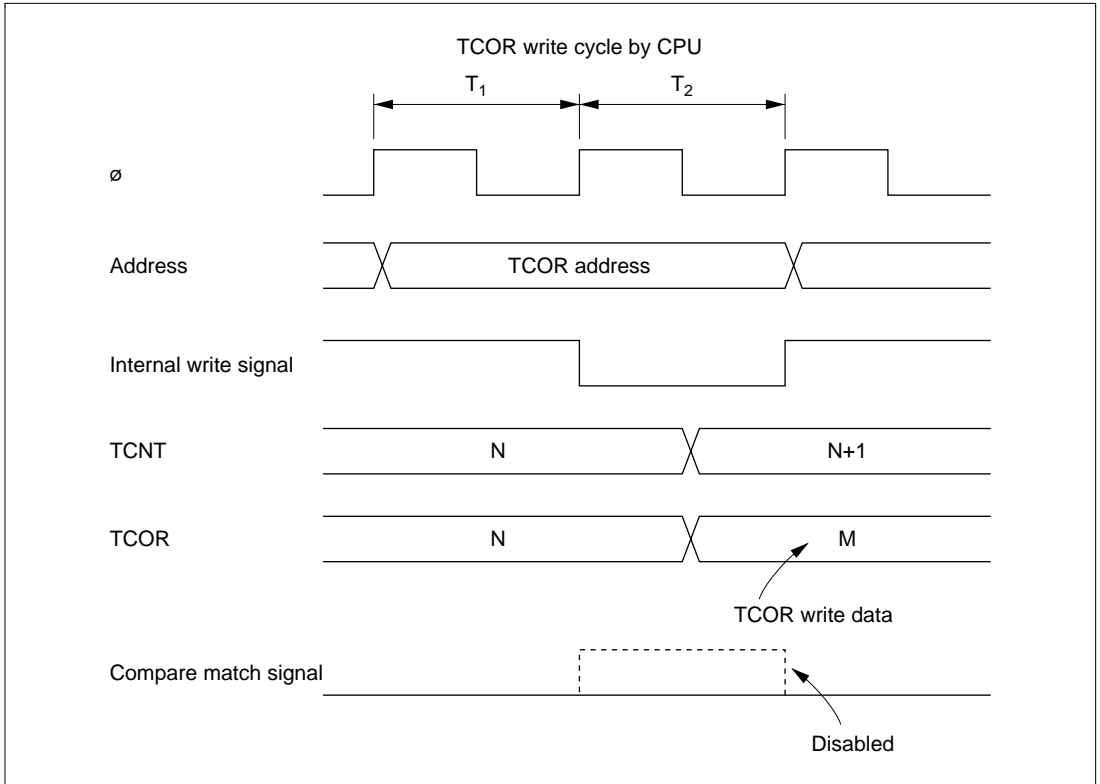

Figure 10-12 Contention between TCOR Write and Compare Match

10.6.4 Contention between Compare Matches A and B

If compare match events A and B occur at the same time, the 8-bit timer operates in accordance with the priorities for the output statuses set for compare match A and compare match B, as shown in table 10-4.

Table 10-4 Timer Output Priorities

Output Setting	Priority
Toggle output	High
1 output	▲ ↑
0 output	
No change	Low

10.6.5 Switching of Internal Clocks and TCNT Operation

TCNT may increment erroneously when the internal clock is switched over. Table 10-5 shows the relationship between the timing at which the internal clock is switched (by writing to the CKS1 and CKS0 bits) and the TCNT operation.

When the TCNT clock is generated from an internal clock, the falling edge of the internal clock pulse is detected. If clock switching causes a change from high to low level, as shown in case 3 in table 10-5, a TCNT clock pulse is generated on the assumption that the switchover is a falling edge. This increments TCNT.

The erroneous incrementation can also happen when switching between internal and external clocks.

Table 10-5 Switching of Internal Clock and TCNT Operation

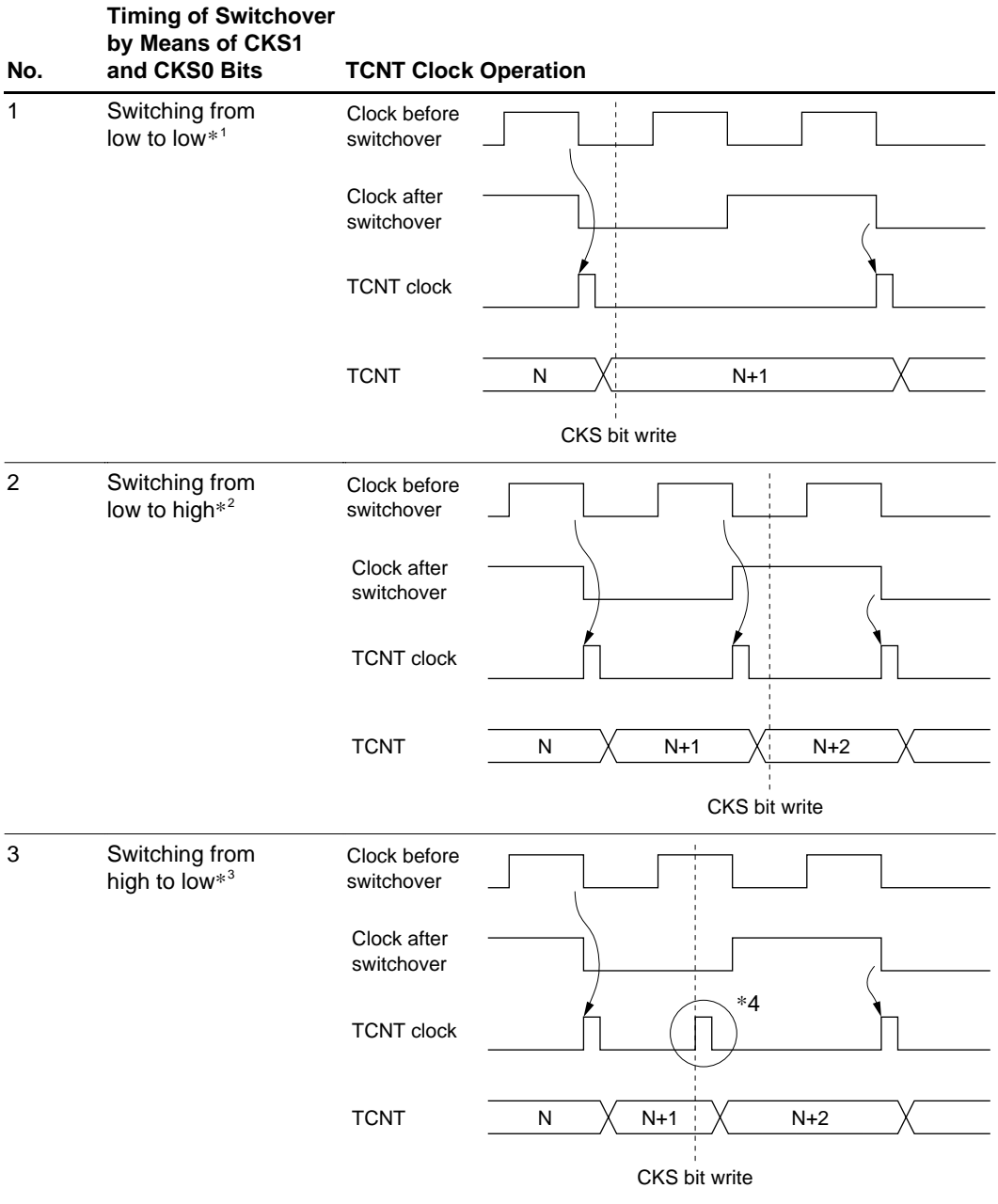

**Timing of Switchover
by Means of CKS1
and CKS0 Bits**

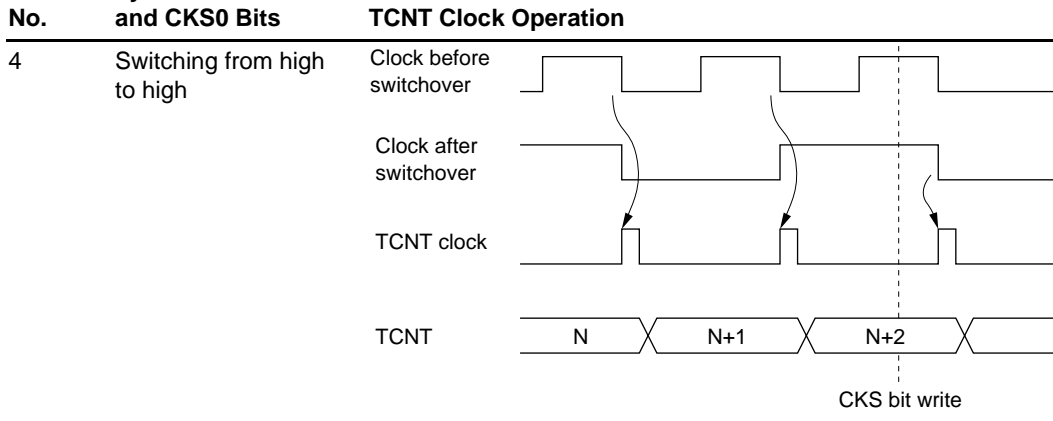

- Notes:
1. Includes switching from low to stop, and from stop to low.
 2. Includes switching from stop to high.
 3. Includes switching from high to stop.
 4. Generated on the assumption that the switchover is a falling edge; TCNT is incremented.

10.6.6 Usage Note

Interrupts and Module Stop Mode: If module stop mode is entered when an interrupt has been requested, it will not be possible to clear the CPU interrupt source or DTC activation source. Interrupts should therefore be disabled before entering module stop mode.

Section 11 Watchdog Timer

11.1 Overview

The H8S/2355 Series has a single-channel on-chip watchdog timer (WDT) for monitoring system operation. The WDT outputs an overflow signal ($\overline{\text{WDTOVF}}$) if a system crash prevents the CPU from writing to the timer counter, allowing it to overflow. At the same time, the WDT can also generate an internal reset signal for the H8S/2355 Series.

When this watchdog function is not needed, the WDT can be used as an interval timer. In interval timer operation, an interval timer interrupt is generated each time the counter overflows.

11.1.1 Features

WDT features are listed below.

- Switchable between watchdog timer mode and interval timer mode
- $\overline{\text{WDTOVF}}$ output when in watchdog timer mode
If the counter overflows, the WDT outputs $\overline{\text{WDTOVF}}$. It is possible to select whether or not the entire H8S/2355 Series is reset at the same time. This internal reset can be a power-on reset or a manual reset.
- Interrupt generation when in interval timer mode
If the counter overflows, the WDT generates an interval timer interrupt.
- Choice of eight counter clock sources.

11.1.2 Block Diagram

Figure 11-1 shows a block diagram of the WDT.

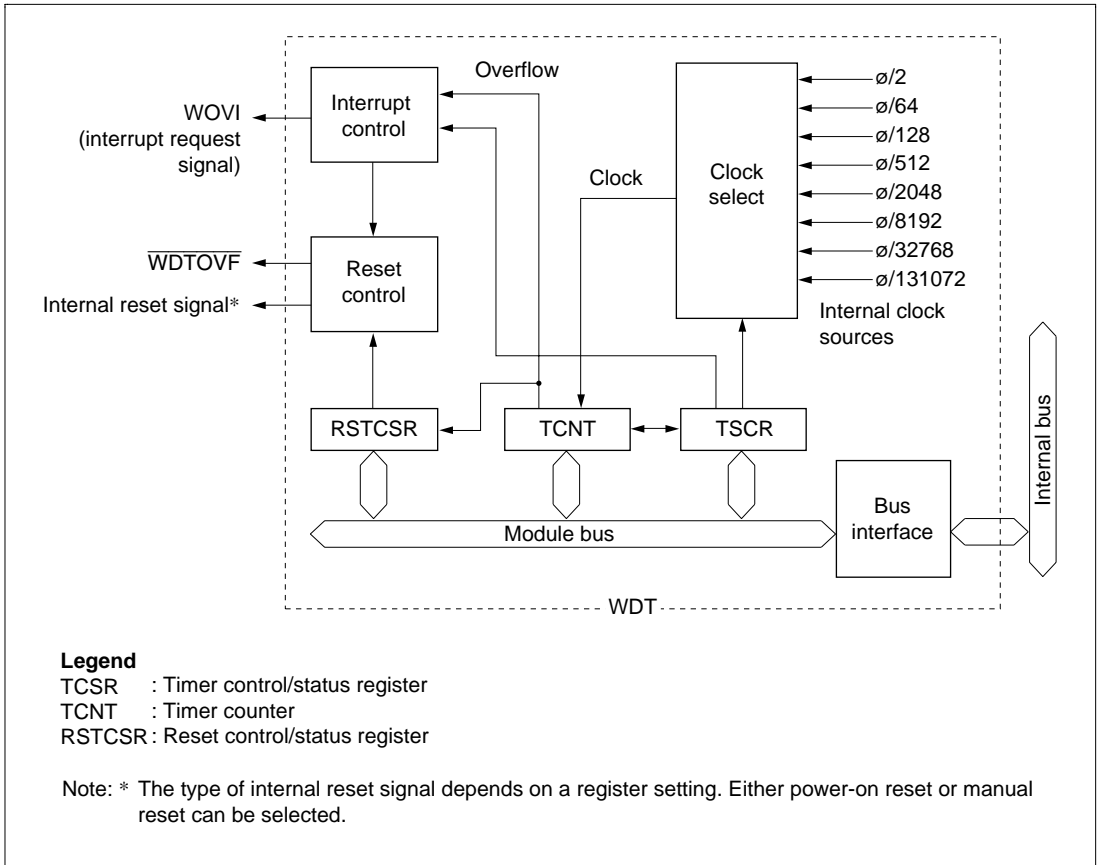

Figure 11-1 Block Diagram of WDT

11.1.3 Pin Configuration

Table 11-1 describes the WDT output pin.

Table 11-1 WDT Pin

Name	Symbol	I/O	Function
Watchdog timer overflow	WDTOVF	Output	Outputs counter overflow signal in watchdog timer mode

11.1.4 Register Configuration

The WDT has three registers, as summarized in table 11-2. These registers control clock selection, WDT mode switching, and the reset signal.

Table 11-2 WDT Registers

Name	Abbreviation	R/W	Initial Value	Address* ¹	
				Write* ²	Read
Timer control/status register	TCSR	R/(W)* ³	H'18	H'FFBC	H'FFBC
Timer counter	TCNT	R/W	H'00	H'FFBC	H'FFBD
Reset control/status register	RSTCSR	R/(W)* ³	H'1F	H'FFBE	H'FFBF

Notes: 1. Lower 16 bits of the address.

2. For details of write operations, see section 11.2.4, Notes on Register Access.

3. Only a write of 0 is permitted to bit 7, to clear the flag.

11.2 Register Descriptions

11.2.1 Timer Counter (TCNT)

Bit	:	7	6	5	4	3	2	1	0
Initial value	:	0	0	0	0	0	0	0	0
R/W	:	R/W	R/W	R/W	R/W	R/W	R/W	R/W	R/W

TCNT is an 8-bit readable/writable* up-counter.

When the TME bit is set to 1 in TCSR, TCNT starts counting pulses generated from the internal clock source selected by bits CKS2 to CKS0 in TCSR. When the count overflows (changes from H'FF to H'00), either the watchdog timer overflow signal ($\overline{\text{WDTOVF}}$) or an interval timer interrupt (WOVI) is generated, depending on the mode selected by the WT/ $\overline{\text{IT}}$ bit in TCSR.

TCNT is initialized to H'00 by a reset, in hardware standby mode, or when the TME bit is cleared to 0. It is not initialized in software standby mode.

Note: * TCNT is write-protected by a password to prevent accidental overwriting. For details see section 11.2.4, Notes on Register Access.

11.2.2 Timer Control/Status Register (TCSR)

Bit	:	7	6	5	4	3	2	1	0
		OVF	WT/ $\overline{\text{IT}}$	TME	—	—	CKS2	CKS1	CKS0
Initial value	:	0	0	0	1	1	0	0	0
R/W	:	R/(W)*	R/W	R/W	—	—	R/W	R/W	R/W

Note: * Can only be written with 0 for flag clearing.

TCSR is an 8-bit readable/writable* register. Its functions include selecting the clock source to be input to TCNT, and the timer mode.

TCSR is initialized to H'18 by a reset and in hardware standby mode. It is not initialized in software standby mode.

Note: * TCSR is write-protected by a password to prevent accidental overwriting. For details see section 11.2.4, Notes on Register Access.

Bit 7—Overflow Flag (OVF): Indicates that TCNT has overflowed from H'FF to H'00, when in interval timer mode. This flag cannot be set during watchdog timer operation.

Bit 7

OVF	Description
0	[Clearing condition] Cleared by reading TCSR when OVF = 1, then writing 0 to OVF (Initial value)
1	[Setting condition] Set when TCNT overflows (changes from H'FF to H'00) in interval timer mode

Bit 6—Timer Mode Select (WT/IT): Selects whether the WDT is used as a watchdog timer or interval timer. If used as an interval timer, the WDT generates an interval timer interrupt request (WOVI) when TCNT overflows. If used as a watchdog timer, the WDT generates the WDTOVF signal when TCNT overflows.

Bit 6

WT/IT	Description
0	Interval timer: Sends the CPU an interval timer interrupt request (WOVI) when TCNT overflows (Initial value)
1	Watchdog timer: Generates the WDTOVF signal when TCNT overflows

Note: * For details of the case where TCNT overflows in watchdog timer mode, see section 11.2.3, Reset Control/Status Register (RSTCSR).

Bit 5—Timer Enable (TME): Selects whether TCNT runs or is halted.

Bit 5

TME	Description
0	TCNT is initialized to H'00 and halted (Initial value)
1	TCNT counts

Bits 4 and 3—Reserved: Read-only bits, always read as 1.

Bits 2 to 0: Clock Select 2 to 0 (CKS2 to CKS0): These bits select one of eight internal clock sources, obtained by dividing the system clock (ϕ), for input to TCNT.

Bit 2	Bit 1	Bit 0	Description	
CKS2	CKS1	CKS0	Clock	Overflow Period (when $\phi = 20 \text{ MHz}$)*
0	0	0	$\phi/2$ (initial value)	25.6 μs
		1	$\phi/64$	819.2 μs
	1	0	$\phi/128$	1.6 ms
		1	$\phi/512$	6.6 ms
1	0	0	$\phi/2048$	26.2 ms
		1	$\phi/8192$	104.9 ms
	1	0	$\phi/32768$	419.4 ms
		1	$\phi/131072$	1.68 s

Note: * The overflow period is the time from when TCNT starts counting up from H'00 until overflow occurs.

11.2.3 Reset Control/Status Register (RSTCSR)

Bit	:	7	6	5	4	3	2	1	0
		WOVF	RSTE	RSTS	—	—	—	—	—
Initial value:		0	0	0	1	1	1	1	1
R/W	:	R/(W)*	R/W	R/W	—	—	—	—	—

Note: * Can only be written with 0 for flag clearing.

RSTCSR is an 8-bit readable/writable* register that controls the generation of the internal reset signal when TCNT overflows, and selects the type of internal reset signal.

RSTCSR is initialized to H'1F by a reset signal from the $\overline{\text{RES}}$ pin, but not by the WDT internal reset signal caused by overflows.

Note: * RSTCSR is write-protected by a password to prevent accidental overwriting. For details see section 11.2.4, Notes on Register Access.

Bit 7—Watchdog Overflow Flag (WOVF): Indicates that TCNT has overflowed (changed from H'FF to H'00) during watchdog timer operation. This bit is not set in interval timer mode.

Bit 7

WOVF	Description	
0	[Clearing condition] Cleared by reading TCSR when WOVF = 1, then writing 0 to WOVF	(Initial value)
1	[Setting condition] Set when TCNT overflows (changed from H'FF to H'00) during watchdog timer operation	

Bit 6—Reset Enable (RSTE): Specifies whether or not a reset signal is generated in the H8S/2355 Series if TCNT overflows during watchdog timer operation.

Bit 6

RSTE	Description	
0	Reset signal is not generated if TCNT overflows*	(Initial value)
1	Reset signal is generated if TCNT overflows	

Note: * The modules within the H8S/2355 Series are not reset, but TCNT and TCSR within the WDT are reset.

Bit 5—Reset Select (RSTS): Selects the type of internal reset generated if TCNT overflows during watchdog timer operation.

For details of the types of resets, see section 4, Exception Handling.

Bit 5

RSTS	Description	
0	Power-on reset	(Initial value)
1	Manual reset	

Bits 4 to 0—Reserved: Read-only bits, always read as 1.

11.2.4 Notes on Register Access

The watchdog timer's TCNT, TCSR, and RSTCSR registers differ from other registers in being more difficult to write to. The procedures for writing to and reading these registers are given below.

Writing to TCNT and TCSR: These registers must be written to by a word transfer instruction. They cannot be written to with byte instructions.

Figure 11-2 shows the format of data written to TCNT and TCSR. TCNT and TCSR both have the same write address. For a write to TCNT, the upper byte of the written word must contain H'5A and the lower byte must contain the write data. For a write to TCSR, the upper byte of the written word must contain H'A5 and the lower byte must contain the write data. This transfers the write data from the lower byte to TCNT or TCSR.

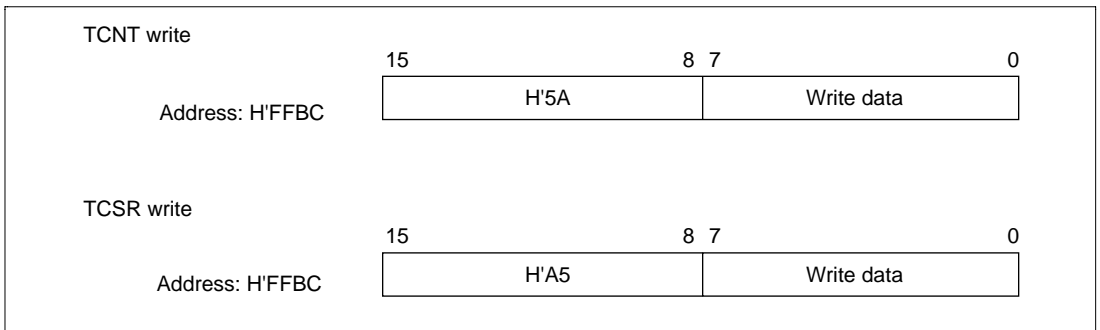

Figure 11-2 Format of Data Written to TCNT and TCSR

Writing to RSTCSR: RSTCSR must be written to by word transfer instruction to address H'FFBE. It cannot be written to with byte instructions.

Figure 11-3 shows the format of data written to RSTCSR. The method of writing 0 to the WOVF bit differs from that for writing to the RSTE and RSTS bits.

To write 0 to the WOVF bit, the write data must have H'A5 in the upper byte and H'00 in the lower byte. This clears the WOVF bit to 0, but has no effect on the RSTE and RSTS bits. To write to the RSTE and RSTS bits, the upper byte must contain H'5A and the lower byte must contain the write data. This writes the values in bits 6 and 5 of the lower byte into the RSTE and RSTS bits, but has no effect on the WOVF bit.

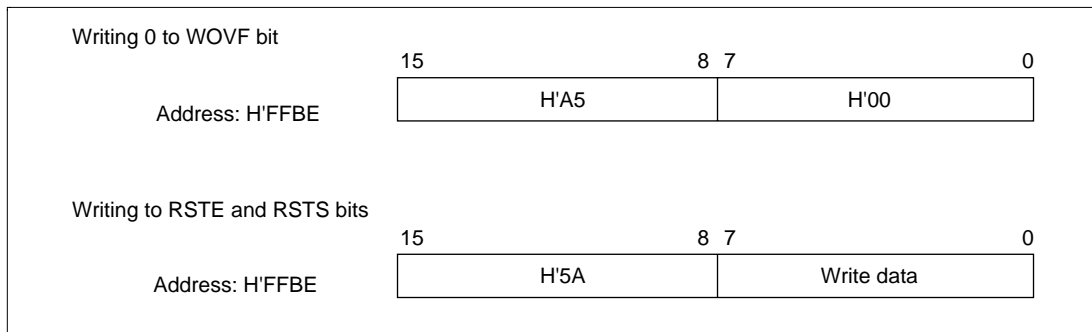

Figure 11-3 Format of Data Written to RSTCSR

Reading TCNT, TCSR, and RSTCSR: These registers are read in the same way as other registers. The read addresses are H'FFBC for TCSR, H'FFBD for TCNT, and H'FFBF for RSTCSR.

11.3 Operation

11.3.1 Watchdog Timer Operation

To use the WDT as a watchdog timer, set the $\overline{WT/IT}$ and TME bits to 1. Software must prevent TCNT overflows by rewriting the TCNT value (normally by writing H'00) before overflows occur. This ensures that TCNT does not overflow while the system is operating normally. If TCNT overflows without being rewritten because of a system crash or other error, the \overline{WDTOVF} signal is output. This is shown in figure 11-4. This \overline{WDTOVF} signal can be used to reset the system. The \overline{WDTOVF} signal is output for 132 states when RSTE = 1, and for 130 states when RSTE = 0.

If TCNT overflows when 1 is set in the RSTE bit in RSTCSR, a signal that resets the H8S/2355 Series internally is generated at the same time as the \overline{WDTOVF} signal. This reset can be selected as a power-on reset or a manual reset, depending on the setting of the RSTS bit in RSTCSR. The internal reset signal is output for 518 states.

If a reset caused by a signal input to the \overline{RES} pin occurs at the same time as a reset caused by a WDT overflow, the \overline{RES} pin reset has priority and the WOVF bit in RSTCSR is cleared to 0.

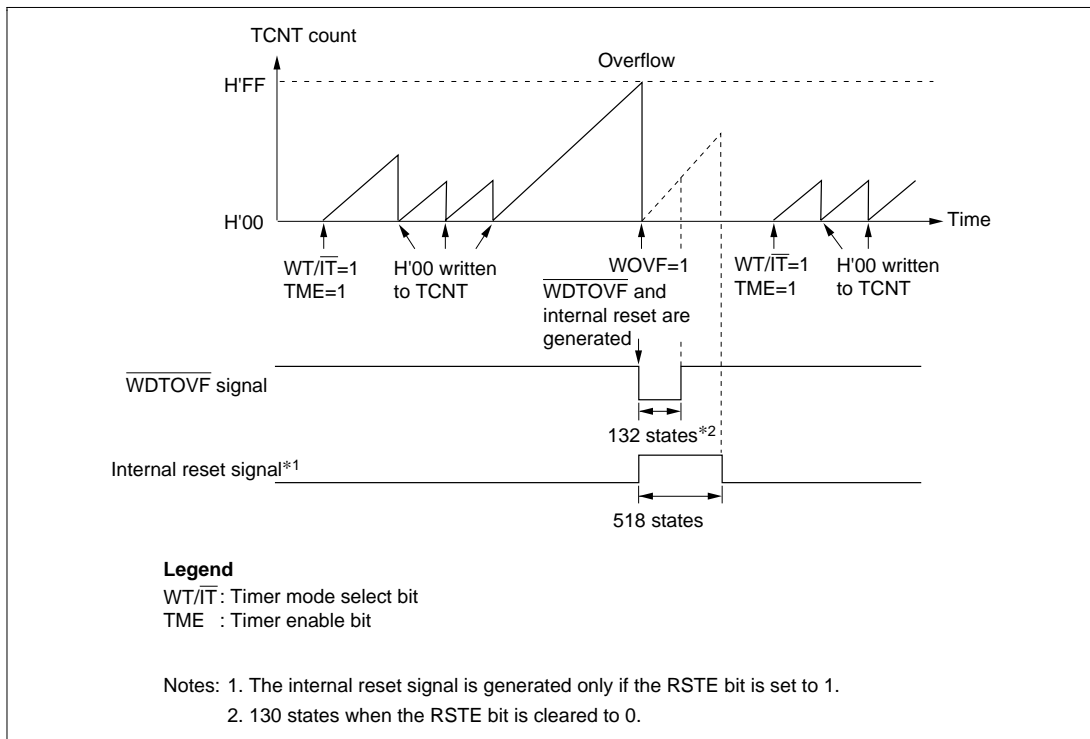

Figure 11-4 Watchdog Timer Operation

11.3.2 Interval Timer Operation

To use the WDT as an interval timer, clear the WT/\overline{IT} bit in TCSR to 0 and set the TME bit to 1. An interval timer interrupt (WOVI) is generated each time TCNT overflows, provided that the WDT is operating as an interval timer, as shown in figure 11-5. This function can be used to generate interrupt requests at regular intervals.

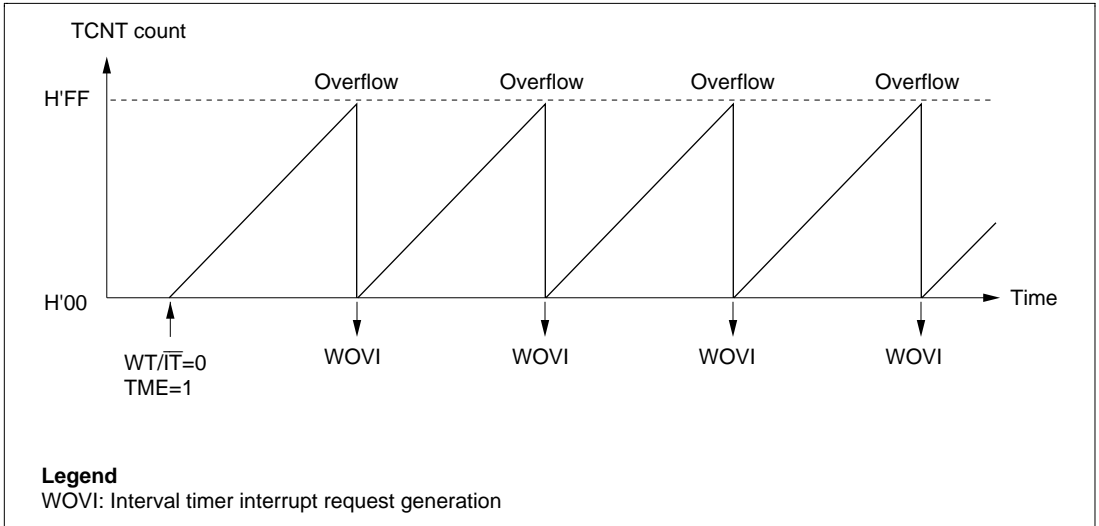

Figure 11-5 Interval Timer Operation

11.3.3 Timing of Setting Overflow Flag (OVF)

The OVF flag is set to 1 if TCNT overflows during interval timer operation. At the same time, an interval timer interrupt (WOVI) is requested. This timing is shown in figure 11-6.

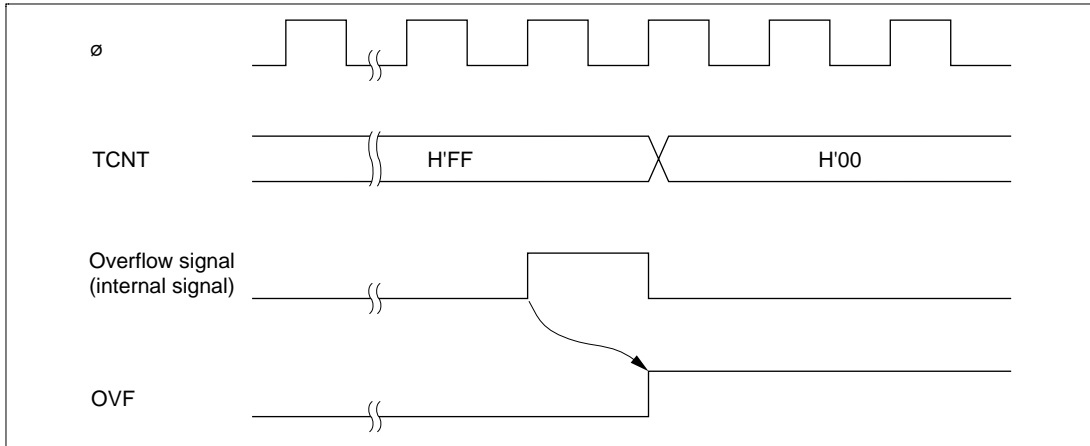

Figure 11-6 Timing of Setting of OVF

11.3.4 Timing of Setting of Watchdog Timer Overflow Flag (WOVF)

The WOVF flag is set to 1 if TCNT overflows during watchdog timer operation. At the same time, the $\overline{\text{WDTOVF}}$ signal goes low. If TCNT overflows while the RSTE bit in RSTCSR is set to 1, an internal reset signal is generated for the entire H8S/2355 Series chip. Figure 11-7 shows the timing in this case.

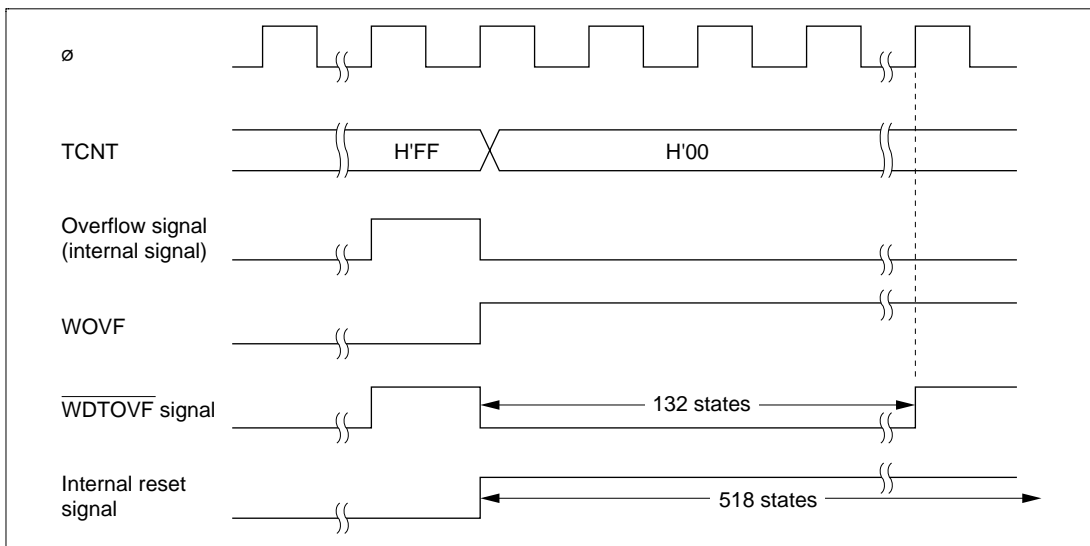

Figure 11-7 Timing of Setting of WOVF

11.4 Interrupts

During interval timer mode operation, an overflow generates an interval timer interrupt (WOVI). The interval timer interrupt is requested whenever the OVF flag is set to 1 in TCSR.

11.5 Usage Notes

11.5.1 Contention between Timer Counter (TCNT) Write and Increment

If a timer counter clock pulse is generated during the T_2 state of a TCNT write cycle, the write takes priority and the timer counter is not incremented. Figure 11-8 shows this operation.

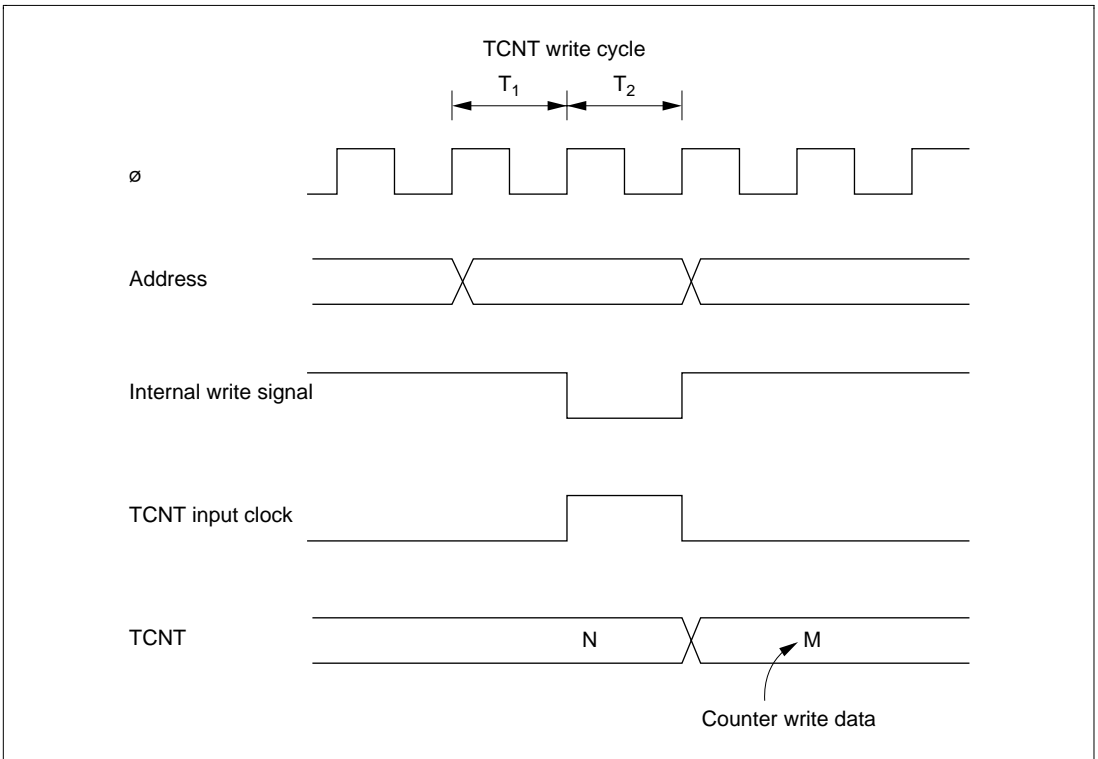

Figure 11-8 Contention between TCNT Write and Increment

11.5.2 Changing Value of CKS2 to CKS0

If bits CKS2 to CKS0 in TCSR are written to while the WDT is operating, errors could occur in the incrementation. Software must stop the watchdog timer (by clearing the TME bit to 0) before changing the value of bits CKS2 to CKS0.

11.5.3 Switching between Watchdog Timer Mode and Interval Timer Mode

If the mode is switched from watchdog timer to interval timer, or vice versa, while the WDT is operating, errors could occur in the incrementation. Software must stop the watchdog timer (by clearing the TME bit to 0) before switching the mode.

11.5.4 System Reset by $\overline{\text{WDTOVF}}$ Signal

If the $\overline{\text{WDTOVF}}$ output signal is input to the $\overline{\text{RES}}$ pin of the H8S/2355 Series, the H8S/2355 Series will not be initialized correctly. Make sure that the $\overline{\text{WDTOVF}}$ signal is not input logically to the $\overline{\text{RES}}$ pin. To reset the entire system by means of the $\overline{\text{WDTOVF}}$ signal, use the circuit shown in figure 11-9.

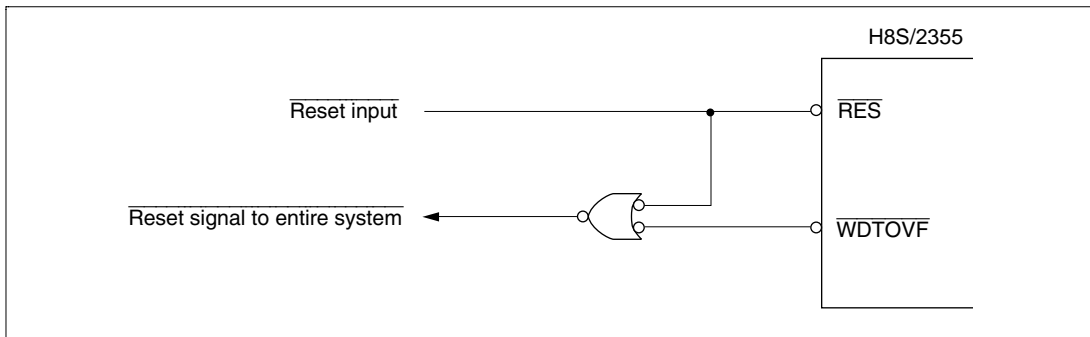

Figure 11-9 Circuit for System Reset by $\overline{\text{WDTOVF}}$ Signal (Example)

11.5.5 Internal Reset in Watchdog Timer Mode

The H8S/2355 Series is not reset internally if TCNT overflows while the RSTE bit is cleared to 0 during watchdog timer operation, but TCNT and TCSR of the WDT are reset.

TCNT, TCSR, and RSTCR cannot be written to while the $\overline{\text{WDTOVF}}$ signal is low. Also note that a read of the WOVF flag is not recognized during this period. To clear the WOVF flag, therefore, read TCSR after the $\overline{\text{WDTOVF}}$ signal goes high, then write 0 to the WOVF flag.

Section 12 Serial Communication Interface (SCI)

12.1 Overview

The H8S/2355 Series is equipped with a 3-channel serial communication interface (SCI). All three channels have the same functions. The SCI can handle both asynchronous and clocked synchronous serial communication. A function is also provided for serial communication between processors (multiprocessor communication function).

12.1.1 Features

SCI features are listed below.

- Choice of asynchronous or clocked synchronous serial communication mode

Asynchronous mode

- Serial data communication executed using asynchronous system in which synchronization is achieved character by character
- Serial data communication can be carried out with standard asynchronous communication chips such as a Universal Asynchronous Receiver/Transmitter (UART) or Asynchronous Communication Interface Adapter (ACIA)
- A multiprocessor communication function is provided that enables serial data communication with a number of processors
- Choice of 12 serial data transfer formats
 - Data length : 7 or 8 bits
 - Stop bit length : 1 or 2 bits
 - Parity : Even, odd, or none
 - Multiprocessor bit : 1 or 0
- Receive error detection : Parity, overrun, and framing errors
- Break detection : Break can be detected by reading the RxD pin level directly in case of a framing error

Clocked Synchronous mode

- Serial data communication synchronized with a clock
 - Serial data communication can be carried out with other chips that have a synchronous communication function
- One serial data transfer format
 - Data length : 8 bits
- Receive error detection : Overrun errors detected

- Full-duplex communication capability
 - The transmitter and receiver are mutually independent, enabling transmission and reception to be executed simultaneously
 - Double-buffering is used in both the transmitter and the receiver, enabling continuous transmission and continuous reception of serial data
- On-chip baud rate generator allows any bit rate to be selected
- Choice of serial clock source: internal clock from baud rate generator or external clock from SCK pin
- Four interrupt sources
 - Four interrupt sources — transmit-data-empty, transmit-end, receive-data-full, and receive error — that can issue requests independently
 - The transmit-data-empty interrupt and receive data full interrupts can activate the data transfer controller (DTC) to execute data transfer
- Choice of LSB-first or MSB-first transfer
 - Can be selected regardless of the communication mode* (except in the case of asynchronous mode bit data)
- Module stop mode can be set
 - As the initial setting, SCI operation is halted. Register access is enabled by exiting module stop mode.

Note: * Descriptions in this section refer to LSB-first transfer.

12.1.2 Block Diagram

Figure 12-1 shows a block diagram of the SCI.

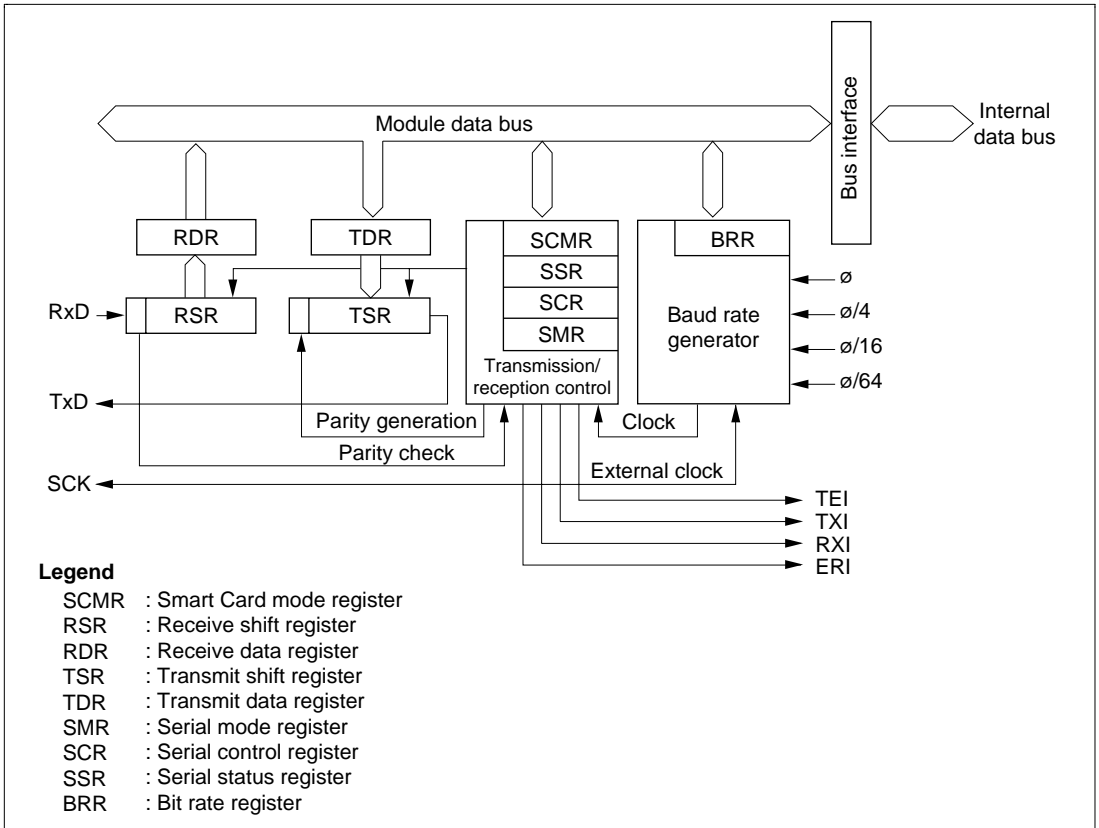

Figure 12-1 Block Diagram of SCI

12.1.3 Pin Configuration

Table 12-1 shows the serial pins for each SCI channel.

Table 12-1 SCI Pins

Channel	Pin Name	Symbol	I/O	Function
0	Serial clock pin 0	SCK0	I/O	SCI0 clock input/output
	Receive data pin 0	RxD0	Input	SCI0 receive data input
	Transmit data pin 0	TxD0	Output	SCI0 transmit data output
1	Serial clock pin 1	SCK1	I/O	SCI1 clock input/output
	Receive data pin 1	RxD1	Input	SCI1 receive data input
	Transmit data pin 1	TxD1	Output	SCI1 transmit data output
2	Serial clock pin 2	SCK2	I/O	SCI2 clock input/output
	Receive data pin 2	RxD2	Input	SCI2 receive data input
	Transmit data pin 2	TxD2	Output	SCI2 transmit data output

12.1.4 Register Configuration

The SCI has the internal registers shown in table 12-2. These registers are used to specify asynchronous mode or clocked synchronous mode, the data format, and the bit rate, and to control transmitter/receiver.

Table 12-2 SCI Registers

Channel	Name	Abbreviation	R/W	Initial Value	Address* ¹
0	Serial mode register 0	SMR0	R/W	H'00	H'FF78
	Bit rate register 0	BRR0	R/W	H'FF	H'FF79
	Serial control register 0	SCR0	R/W	H'00	H'FF7A
	Transmit data register 0	TDR0	R/W	H'FF	H'FF7B
	Serial status register 0	SSR0	R/(W)* ²	H'84	H'FF7C
	Receive data register 0	RDR0	R	H'00	H'FF7D
	Smart card mode register 0	SCMR0	R/W	H'F2	H'FF7E
1	Serial mode register 1	SMR1	R/W	H'00	H'FF80
	Bit rate register 1	BRR1	R/W	H'FF	H'FF81
	Serial control register 1	SCR1	R/W	H'00	H'FF82
	Transmit data register 1	TDR1	R/W	H'FF	H'FF83
	Serial status register 1	SSR1	R/(W)* ²	H'84	H'FF84
	Receive data register 1	RDR1	R	H'00	H'FF85
	Smart card mode register 1	SCMR1	R/W	H'F2	H'FF86
2	Serial mode register 2	SMR2	R/W	H'00	H'FF88
	Bit rate register 2	BRR2	R/W	H'FF	H'FF89
	Serial control register 2	SCR2	R/W	H'00	H'FF8A
	Transmit data register 2	TDR2	R/W	H'FF	H'FF8B
	Serial status register 2	SSR2	R/(W)* ²	H'84	H'FF8C
	Receive data register 2	RDR2	R	H'00	H'FF8D
	Smart card mode register 2	SCMR2	R/W	H'F2	H'FF8E
All	Module stop control register MSTPCR		R/W	H'3FFF	H'FF3C

- Notes: 1. Lower 16 bits of the address.
 2. Can only be written with 0 for flag clearing.

12.2 Register Descriptions

12.2.1 Receive Shift Register (RSR)

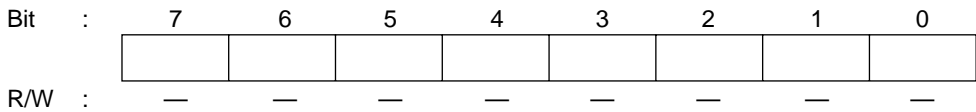

RSR is a register used to receive serial data.

The SCI sets serial data input from the RxD pin in RSR in the order received, starting with the LSB (bit 0), and converts it to parallel data. When one byte of data has been received, it is transferred to RDR automatically.

RSR cannot be directly read or written to by the CPU.

12.2.2 Receive Data Register (RDR)

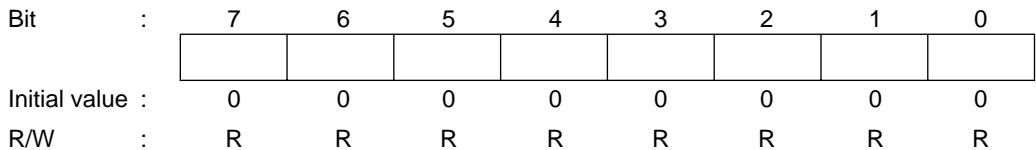

RDR is a register that stores received serial data.

When the SCI has received one byte of serial data, it transfers the received serial data from RSR to RDR where it is stored, and completes the receive operation. After this, RSR is receive-enabled.

Since RSR and RDR function as a double buffer in this way, enables continuous receive operations to be performed.

RDR is a read-only register, and cannot be written to by the CPU.

RDR is initialized to H'00 by a reset, and in standby mode or module stop mode.

12.2.3 Transmit Shift Register (TSR)

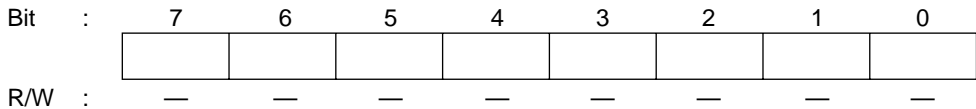

TSR is a register used to transmit serial data.

To perform serial data transmission, the SCI first transfers transmit data from TDR to TSR, then sends the data to the TxD pin starting with the LSB (bit 0).

When transmission of one byte is completed, the next transmit data is transferred from TDR to TSR, and transmission started, automatically. However, data transfer from TDR to TSR is not performed if the TDRE bit in SSR is set to 1.

TSR cannot be directly read or written to by the CPU.

12.2.4 Transmit Data Register (TDR)

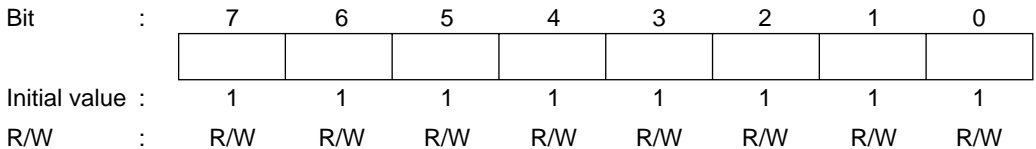

TDR is an 8-bit register that stores data for serial transmission.

When the SCI detects that TSR is empty, it transfers the transmit data written in TDR to TSR and starts serial transmission. Continuous serial transmission can be carried out by writing the next transmit data to TDR during serial transmission of the data in TSR.

TDR can be read or written to by the CPU at all times.

TDR is initialized to H'FF by a reset, and in standby mode or module stop mode.

12.2.5 Serial Mode Register (SMR)

Bit	:	7	6	5	4	3	2	1	0
		C/ \bar{A}	CHR	PE	O/ \bar{E}	STOP	MP	CKS1	CKS0
Initial value	:	0	0	0	0	0	0	0	0
R/W	:	R/W	R/W	R/W	R/W	R/W	R/W	R/W	R/W

SMR is an 8-bit register used to set the SCI's serial transfer format and select the baud rate generator clock source.

SMR can be read or written to by the CPU at all times.

SMR is initialized to H'00 by a reset, and in standby mode or module stop mode.

Bit 7—Communication Mode (C/ \bar{A}): Selects asynchronous mode or clocked synchronous mode as the SCI operating mode.

Bit 7

C/ \bar{A}	Description
0	Asynchronous mode (Initial value)
1	Clocked synchronous mode

Bit 6—Character Length (CHR): Selects 7 or 8 bits as the data length in asynchronous mode. In clocked synchronous mode, a fixed data length of 8 bits is used regardless of the CHR setting.

Bit 6

CHR	Description
0	8-bit data (Initial value)
1	7-bit data*

Note: * When 7-bit data is selected, the MSB (bit 7) of TDR is not transmitted, and it is not possible to choose between LSB-first or MSB-first transfer.

Bit 5—Parity Enable (PE): In asynchronous mode, selects whether or not parity bit addition is performed in transmission, and parity bit checking in reception. In clocked synchronous mode with a multiprocessor format, parity bit addition and checking is not performed, regardless of the PE bit setting.

Bit 5

PE	Description
0	Parity bit addition and checking disabled (Initial value)
1	Parity bit addition and checking enabled*

Note:* When the PE bit is set to 1, the parity (even or odd) specified by the O/\bar{E} bit is added to transmit data before transmission. In reception, the parity bit is checked for the parity (even or odd) specified by the O/\bar{E} bit.

Bit 4—Parity Mode (O/\bar{E}): Selects either even or odd parity for use in parity addition and checking.

The O/\bar{E} bit setting is only valid when the PE bit is set to 1, enabling parity bit addition and checking, in asynchronous mode. The O/\bar{E} bit setting is invalid in clocked synchronous mode, and when parity addition and checking is disabled in asynchronous mode.

Bit 4

O/\bar{E}	Description
0	Even parity* ¹ (Initial value)
1	Odd parity* ²

Notes: 1. When even parity is set, parity bit addition is performed in transmission so that the total number of 1 bits in the transmit character plus the parity bit is even. In reception, a check is performed to see if the total number of 1 bits in the receive character plus the parity bit is even.

2. When odd parity is set, parity bit addition is performed in transmission so that the total number of 1 bits in the transmit character plus the parity bit is odd. In reception, a check is performed to see if the total number of 1 bits in the receive character plus the parity bit is odd.

Bit 3—Stop Bit Length (STOP): Selects 1 or 2 bits as the stop bit length in asynchronous mode. The STOP bits setting is only valid in asynchronous mode. If clocked synchronous mode is set the STOP bit setting is invalid since stop bits are not added.

Bit 3

STOP	Description
0	1 stop bit: In transmission, a single 1 bit (stop bit) is added to the end of a transmit character before it is sent. (Initial value)
1	2 stop bits: In transmission, two 1 bits (stop bits) are added to the end of a transmit character before it is sent.

In reception, only the first stop bit is checked, regardless of the STOP bit setting. If the second stop bit is 1, it is treated as a stop bit; if it is 0, it is treated as the start bit of the next transmit character.

Bit 2—Multiprocessor Mode (MP): Selects multiprocessor format. When multiprocessor format is selected, the PE bit and O/\bar{E} bit parity settings are invalid. The MP bit setting is only valid in asynchronous mode; it is invalid in clocked synchronous mode.

For details of the multiprocessor communication function, see section 12.3.3, Multiprocessor Communication Function.

Bit 2

MP	Description
0	Multiprocessor function disabled (Initial value)
1	Multiprocessor format selected

Bits 1 and 0—Clock Select 1 and 0 (CKS1, CKS0): These bits select the clock source for the baud rate generator. The clock source can be selected from \emptyset , $\emptyset/4$, $\emptyset/16$, and $\emptyset/64$, according to the setting of bits CKS1 and CKS0.

For the relation between the clock source, the bit rate register setting, and the baud rate, see section 12.2.8, Bit Rate Register.

Bit 1	Bit 0	Description
CKS1	CKS0	
0	0	\emptyset clock (Initial value)
	1	$\emptyset/4$ clock
1	0	$\emptyset/16$ clock
	1	$\emptyset/64$ clock

12.2.6 Serial Control Register (SCR)

Bit	:	7	6	5	4	3	2	1	0
		TIE	RIE	TE	RE	MPIE	TEIE	CKE1	CKE0
Initial value	:	0	0	0	0	0	0	0	0
R/W	:	R/W	R/W	R/W	R/W	R/W	R/W	R/W	R/W

SCR is a register that performs enabling or disabling of SCI transfer operations, serial clock output in asynchronous mode, and interrupt requests, and selection of the serial clock source.

SCR can be read or written to by the CPU at all times.

SCR is initialized to H'00 by a reset, and in standby mode or module stop mode.

Bit 7—Transmit Interrupt Enable (TIE): Enables or disables transmit data empty interrupt (TXI) request generation when serial transmit data is transferred from TDR to TSR and the TDRE flag in SSR is set to 1.

Bit 7	Description
TIE	
0	Transmit data empty interrupt (TXI) requests disabled* (Initial value)
1	Transmit data empty interrupt (TXI) requests enabled

Note:* TXI interrupt request cancellation can be performed by reading 1 from the TDRE flag, then clearing it to 0, or clearing the TIE bit to 0.

Bit 6—Receive Interrupt Enable (RIE): Enables or disables receive data full interrupt (RXI) request and receive error interrupt (ERI) request generation when serial receive data is transferred from RSR to RDR and the RDRF flag in SSR is set to 1.

Bit 6

RIE	Description
0	Receive data full interrupt (RXI) request and receive error interrupt (ERI) request disabled* (Initial value)
1	Receive data full interrupt (RXI) request and receive error interrupt (ERI) request enabled

Note:* RXI and ERI interrupt request cancellation can be performed by reading 1 from the RDRF flag, or the FER, PER, or ORER flag, then clearing the flag to 0, or clearing the RIE bit to 0.

Bit 5—Transmit Enable (TE): Enables or disables the start of serial transmission by the SCI.

Bit 5

TE	Description
0	Transmission disabled* ¹ (Initial value)
1	Transmission enabled* ²

Notes: 1. The TDRE flag in SSR is fixed at 1.
 2. In this state, serial transmission is started when transmit data is written to TDR and the TDRE flag in SSR is cleared to 0.
 SMR setting must be performed to decide the transfer format before setting the TE bit to 1.

Bit 4—Receive Enable (RE): Enables or disables the start of serial reception by the SCI.

Bit 4

RE	Description
0	Reception disabled* ¹ (Initial value)
1	Reception enabled* ²

Notes: 1. Clearing the RE bit to 0 does not affect the RDRF, FER, PER, and ORER flags, which retain their states.
 2. Serial reception is started in this state when a start bit is detected in asynchronous mode or serial clock input is detected in clocked synchronous mode.
 SMR setting must be performed to decide the transfer format before setting the RE bit to 1.

Bit 3—Multiprocessor Interrupt Enable (MPIE): Enables or disables multiprocessor interrupts. The MPIE bit setting is only valid in asynchronous mode when the MP bit in SMR is set to 1.

The MPIE bit setting is invalid in clocked synchronous mode or when the MP bit is cleared to 0.

Bit 3

MPIE	Description
0	Multiprocessor interrupts disabled (normal reception performed) (Initial value) [Clearing conditions] <ul style="list-style-type: none"> • When the MPIE bit is cleared to 0 • When MPB= 1 data is received
1	Multiprocessor interrupts enabled* Receive interrupt (RXI) requests, receive error interrupt (ERI) requests, and setting of the RDRF, FER, and ORER flags in SSR are disabled until data with the multiprocessor bit set to 1 is received.

Note: * When receive data including MPB = 0 is received, receive data transfer from RSR to RDR, receive error detection, and setting of the RDRF, FER, and ORER flags in SSR, is not performed. When receive data including MPB = 1 is received, the MPB bit in SSR is set to 1, the MPIE bit is cleared to 0 automatically, and generation of RXI and ERI interrupts (when the TIE and RIE bits in SCR are set to 1) and FER and ORER flag setting is enabled.

Bit 2—Transmit End Interrupt Enable (TEIE): Enables or disables transmit end interrupt (TEI) request generation when there is no valid transmit data in TDR in MSB data transmission.

Bit 2

TEIE	Description
0	Transmit end interrupt (TEI) request disabled* (Initial value)
1	Transmit end interrupt (TEI) request enabled*

Note: * TEI cancellation can be performed by reading 1 from the TDRE flag in SSR, then clearing it to 0 and clearing the TEND flag to 0, or clearing the TEIE bit to 0.

Bits 1 and 0—Clock Enable 1 and 0 (CKE1, CKE0): These bits are used to select the SCI clock source and enable or disable clock output from the SCK pin. The combination of the CKE1 and CKE0 bits determines whether the SCK pin functions as an I/O port, the serial clock output pin, or the serial clock input pin.

The setting of the CKE0 bit, however, is only valid for internal clock operation (CKE1 = 0) in asynchronous mode. The CKE0 bit setting is invalid in clocked synchronous mode, and in the case of external clock operation (CKE1 = 1). Note that the SCI's operating mode must be decided using SMR before setting the CKE1 and CKE0 bits.

For details of clock source selection, see table 12.9 in section 12.3, Operation.

Bit 1	Bit 0	Description	
CKE1	CKE0		
0	0	Asynchronous mode	Internal clock/SCK pin functions as I/O port* ¹
		Clocked synchronous mode	Internal clock/SCK pin functions as serial clock output
	1	Asynchronous mode	Internal clock/SCK pin functions as clock output* ²
		Clocked synchronous mode	Internal clock/SCK pin functions as serial clock output
1	0	Asynchronous mode	External clock/SCK pin functions as clock input* ³
		Clocked synchronous mode	External clock/SCK pin functions as serial clock input
	1	Asynchronous mode	External clock/SCK pin functions as clock input* ³
		Clocked synchronous mode	External clock/SCK pin functions as serial clock input

Notes: 1. Initial value

2. Outputs a clock of the same frequency as the bit rate.

3. Inputs a clock with a frequency 16 times the bit rate.

12.2.7 Serial Status Register (SSR)

Bit	:	7	6	5	4	3	2	1	0
		TDRE	RDRF	ORER	FER	PER	TEND	MPB	MPBT
Initial value	:	1	0	0	0	0	1	0	0
R/W	:	R/(W)*	R/(W)*	R/(W)*	R/(W)*	R/(W)*	R	R	R/W

Note: Only 0 can be written, to clear the flag.

SSR is an 8-bit register containing status flags that indicate the operating status of the SCI, and multiprocessor bits.

SSR can be read or written to by the CPU at all times. However, 1 cannot be written to flags TDRE, RDRF, ORER, PER, and FER. Also note that in order to clear these flags they must be read as 1 beforehand. The TEND flag and MPB flag are read-only flags and cannot be modified.

SSR is initialized to H'84 by a reset, and in standby mode or module stop mode.

Bit 7—Transmit Data Register Empty (TDRE): Indicates that data has been transferred from TDR to TSR and the next serial data can be written to TDR.

Bit 7

TDRE	Description
0	[Clearing conditions] <ul style="list-style-type: none"> When 0 is written to TDRE after reading TDRE = 1 When the DTC is activated by a TXI interrupt and writes data to TDR
1	[Setting conditions] (Initial value) <ul style="list-style-type: none"> When the TE bit in SCR is 0 When data is transferred from TDR to TSR and data can be written to TDR

Bit 6—Receive Data Register Full (RDRF): Indicates that the received data is stored in RDR.

Bit 6

RDRF	Description
0	[Clearing conditions] (Initial value) <ul style="list-style-type: none"> When 0 is written to RDRF after reading RDRF = 1 When the DTC is activated by an RXI interrupt and reads data from RDR
1	[Setting condition] <p>When serial reception ends normally and receive data is transferred from RSR to RDR</p>

Note: RDR and the RDRF flag are not affected and retain their previous values when an error is detected during reception or when the RE bit in SCR is cleared to 0.

If reception of the next data is completed while the RDRF flag is still set to 1, an overrun error will occur and the receive data will be lost.

Bit 5—Overrun Error (ORER): Indicates that an overrun error occurred during reception, causing abnormal termination.

Bit 5

ORER	Description
0	[Clearing condition] (Initial value)* ¹ When 0 is written to ORER after reading ORER = 1
1	[Setting condition] When the next serial reception is completed while RDRF = 1

- Notes:
1. The ORER flag is not affected and retains its previous state when the RE bit in SCR is cleared to 0.
 2. The receive data prior to the overrun error is retained in RDR, and the data received subsequently is lost. Also, subsequent serial reception cannot be continued while the ORER flag is set to 1. In clocked synchronous mode, serial transmission cannot be continued, either.

Bit 4—Framing Error (FER): Indicates that a framing error occurred during reception in asynchronous mode, causing abnormal termination.

Bit 4

FER	Description
0	[Clearing condition] (Initial value)* ¹ <ul style="list-style-type: none">• When 0 is written to FER after reading FER = 1
1	[Setting condition] When the SCI checks whether the stop bit at the end of the receive data when reception ends, and the stop bit is 0 * ²

- Notes:
1. The FER flag is not affected and retains its previous state when the RE bit in SCR is cleared to 0.
 2. In 2-stop-bit mode, only the first stop bit is checked for a value of 0; the second stop bit is not checked. If a framing error occurs, the receive data is transferred to RDR but the RDRF flag is not set. Also, subsequent serial reception cannot be continued while the FER flag is set to 1. In clocked synchronous mode, serial transmission cannot be continued, either.

Bit 3—Parity Error (PER): Indicates that a parity error occurred during reception using parity addition in asynchronous mode, causing abnormal termination.

Bit 3

PER	Description	
0	[Clearing condition] When 0 is written to PER after reading PER = 1	(Initial value)* ¹
1	[Setting condition] When, in reception, the number of 1 bits in the receive data plus the parity bit does not match the parity setting (even or odd) specified by the O/Ē bit in SMR* ²	

- Notes:
1. The PER flag is not affected and retains its previous state when the RE bit in SCR is cleared to 0.
 2. If a parity error occurs, the receive data is transferred to RDR but the RDRF flag is not set. Also, subsequent serial reception cannot be continued while the PER flag is set to 1. In clocked synchronous mode, serial transmission cannot be continued, either.

Bit 2—Transmit End (TEND): Indicates that there is no valid data in TDR when the last bit of the transmit character is sent, and transmission has been ended.

The TEND flag is read-only and cannot be modified.

Bit 2

TEND	Description	
0	[Clearing conditions] <ul style="list-style-type: none"> • When 0 is written to TDRE after reading TDRE = 1 • When the DTC is activated by a TXI interrupt and writes data to TDR 	
1	[Setting conditions] <ul style="list-style-type: none"> • When the TE bit in SCR is 0 • When TDRE = 1 at transmission of the last bit of a 1-byte serial transmit character 	(Initial value)

Bit 1—Multiprocessor Bit (MPB): When reception is performed using multiprocessor format in asynchronous mode, MPB stores the multiprocessor bit in the receive data.

MPB is a read-only bit, and cannot be modified.

Bit 1

MPB	Description	
0	[Clearing condition] When data with a 0 multiprocessor bit is received	(Initial value)*
1	[Setting condition] When data with a 1 multiprocessor bit is received	

Note: * Retains its previous state when the RE bit in SCR is cleared to 0 with multiprocessor format.

Bit 0—Multiprocessor Bit Transfer (MPBT): When transmission is performed using multiprocessor format in asynchronous mode, MPBT stores the multiprocessor bit to be added to the transmit data.

The MPBT bit setting is invalid when multiprocessor format is not used, when not transmitting, and in clocked synchronous mode.

Bit 0

MPBT	Description
0	Data with a 0 multiprocessor bit is transmitted (Initial value)
1	Data with a 1 multiprocessor bit is transmitted

12.2.8 Bit Rate Register (BRR)

Bit	:	7	6	5	4	3	2	1	0
		<input type="text"/>	<input type="text"/>	<input type="text"/>	<input type="text"/>	<input type="text"/>	<input type="text"/>	<input type="text"/>	<input type="text"/>
Initial value	:	1	1	1	1	1	1	1	1
R/W	:	R/W	R/W	R/W	R/W	R/W	R/W	R/W	R/W

BRR is an 8-bit register that sets the serial transfer bit rate in accordance with the baud rate generator operating clock selected by bits CKS1 and CKS0 in SMR.

BRR can be read or written to by the CPU at all times.

BRR is initialized to H'FF by a reset, and in standby mode or module stop mode.

As baud rate generator control is performed independently for each channel, different values can be set for each channel.

Table 12-3 shows sample BRR settings in asynchronous mode, and table 12-4 shows sample BRR settings in clocked synchronous mode.

Table 12-3 BRR Settings for Various Bit Rates (Asynchronous Mode)

Bit Rate (bit/s)	$\phi = 2 \text{ MHz}$			$\phi = 2.097152 \text{ MHz}$			$\phi = 2.4576 \text{ MHz}$			$\phi = 3 \text{ MHz}$		
	n	N	Error (%)	n	N	Error (%)	n	N	Error (%)	n	N	Error (%)
110	1	141	0.03	1	148	-0.04	1	174	-0.26	1	212	0.03
150	1	103	0.16	1	108	0.21	1	127	0.00	1	155	0.16
300	0	207	0.16	0	217	0.21	0	255	0.00	1	77	0.16
600	0	103	0.16	0	108	0.21	0	127	0.00	0	155	0.16
1200	0	51	0.16	0	54	-0.70	0	63	0.00	0	77	0.16
2400	0	25	0.16	0	26	1.14	0	31	0.00	0	38	0.16
4800	0	12	0.16	0	13	-2.48	0	15	0.00	0	19	-2.34
9600	0	6	—	0	6	-2.48	0	7	0.00	0	9	-2.34
19200	0	2	—	0	2	—	0	3	0.00	0	4	-2.34
31250	0	1	0.00	0	1	—	0	1	—	0	2	0.00
38400	0	1	—	0	1	—	0	1	0.00	—	—	—

Bit Rate (bit/s)	$\phi = 3.6864 \text{ MHz}$			$\phi = 4 \text{ MHz}$			$\phi = 4.9152 \text{ MHz}$			$\phi = 5 \text{ MHz}$		
	n	N	Error (%)	n	N	Error (%)	n	N	Error (%)	n	N	Error (%)
110	2	64	0.70	2	70	0.03	2	86	0.31	2	88	-0.25
150	1	191	0.00	1	207	0.16	1	255	0.00	2	64	0.16
300	1	95	0.00	1	103	0.16	1	127	0.00	1	129	0.16
600	0	191	0.00	0	207	0.16	0	255	0.00	1	64	0.16
1200	0	95	0.00	0	103	0.16	0	127	0.00	0	129	0.16
2400	0	47	0.00	0	51	0.16	0	63	0.00	0	64	0.16
4800	0	23	0.00	0	25	0.16	0	31	0.00	0	32	-1.36
9600	0	11	0.00	0	12	0.16	0	15	0.00	0	15	1.73
19200	0	5	0.00	0	6	—	0	7	0.00	0	7	1.73
31250	—	—	—	0	3	0.00	0	4	-1.70	0	4	0.00
38400	0	2	0.00	0	2	—	0	3	0.00	0	3	1.73

Bit Rate (bit/s)	$\phi = 6 \text{ MHz}$			$\phi = 6.144 \text{ MHz}$			$\phi = 7.3728 \text{ MHz}$			$\phi = 8 \text{ MHz}$		
	n	N	Error (%)	n	N	Error (%)	n	N	Error (%)	n	N	Error (%)
110	2	106	-0.44	2	108	0.08	2	130	-0.07	2	141	0.03
150	2	77	0.16	2	79	0.00	2	95	0.00	2	103	0.16
300	1	155	0.16	1	159	0.00	1	191	0.00	1	207	0.16
600	1	77	0.16	1	79	0.00	1	95	0.00	1	103	0.16
1200	0	155	0.16	0	159	0.00	0	191	0.00	0	207	0.16
2400	0	77	0.16	0	79	0.00	0	95	0.00	0	103	0.16
4800	0	38	0.16	0	39	0.00	0	47	0.00	0	51	0.16
9600	0	19	-2.34	0	19	0.00	0	23	0.00	0	25	0.16
19200	0	9	-2.34	0	9	0.00	0	11	0.00	0	12	0.16
31250	0	5	0.00	0	5	2.40	0	6	5.33	0	7	0.00
38400	0	4	-2.34	0	4	0.00	0	5	0.00	0	6	—

Bit Rate (bit/s)	$\phi = 9.8304 \text{ MHz}$			$\phi = 10 \text{ MHz}$			$\phi = 12 \text{ MHz}$			$\phi = 12.288 \text{ MHz}$		
	n	N	Error (%)	n	N	Error (%)	n	N	Error (%)	n	N	Error (%)
110	2	174	-0.26	2	177	-0.25	2	212	0.03	2	217	0.08
150	2	127	0.00	2	129	0.16	2	155	0.16	2	159	0.00
300	1	255	0.00	2	64	0.16	2	77	0.16	2	79	0.00
600	1	127	0.00	1	129	0.16	1	155	0.16	1	159	0.00
1200	0	255	0.00	1	64	0.16	1	77	0.16	1	79	0.00
2400	0	127	0.00	0	129	0.16	0	155	0.16	0	159	0.00
4800	0	63	0.00	0	64	0.16	0	77	0.16	0	79	0.00
9600	0	31	0.00	0	32	-1.36	0	38	0.16	0	39	0.00
19200	0	15	0.00	0	15	1.73	0	19	-2.34	0	19	0.00
31250	0	9	-1.70	0	9	0.00	0	11	0.00	0	11	2.40
38400	0	7	0.00	0	7	1.73	0	9	-2.34	0	9	0.00

Bit Rate (bit/s)	$\phi = 14$ MHz			$\phi = 14.7456$ MHz			$\phi = 16$ MHz			$\phi = 17.2032$ MHz		
	n	N	Error (%)	n	N	Error (%)	n	N	Error (%)	n	N	Error (%)
110	2	248	-0.17	3	64	0.70	3	70	0.03	3	75	0.48
150	2	181	0.16	2	191	0.00	2	207	0.16	2	223	0.00
300	2	90	0.16	2	95	0.00	2	103	0.16	2	111	0.00
600	1	181	0.16	1	191	0.00	1	207	0.16	1	223	0.00
1200	1	90	0.16	1	95	0.00	1	103	0.16	1	111	0.00
2400	0	181	0.16	0	191	0.00	0	207	0.16	0	223	0.00
4800	0	90	0.16	0	95	0.00	0	103	0.16	0	111	0.00
9600	0	45	-0.93	0	47	0.00	0	51	0.16	0	55	0.00
19200	0	22	-0.93	0	23	0.00	0	25	0.16	0	27	0.00
31250	0	13	0.00	0	14	-1.70	0	15	0.00	0	16	1.20
38400	0	10	—	0	11	0.00	0	12	0.16	0	13	0.00

Bit Rate (bit/s)	$\phi = 18$ MHz			$\phi = 19.6608$ MHz			$\phi = 20$ MHz		
	n	N	Error (%)	n	N	Error (%)	n	N	Error (%)
110	3	79	-0.12	3	86	0.31	3	88	-0.25
150	2	233	0.16	2	255	0.00	3	64	0.16
300	2	116	0.16	2	127	0.00	2	129	0.16
600	1	233	0.16	1	255	0.00	2	64	0.16
1200	1	116	0.16	1	127	0.00	1	129	0.16
2400	0	233	0.16	0	255	0.00	1	64	0.16
4800	0	116	0.16	0	127	0.00	0	129	0.16
9600	0	58	-0.69	0	63	0.00	0	64	0.16
19200	0	28	1.02	0	31	0.00	0	32	-1.36
31250	0	17	0.00	0	19	-1.70	0	19	0.00
38400	0	14	-2.34	0	15	0.00	0	15	1.73

Table 12-4 BRR Settings for Various Bit Rates (Clocked Synchronous Mode)

Bit Rate (bit/s)	ø = 2 MHz		ø = 4 MHz		ø = 8 MHz		ø = 10 MHz		ø = 16 MHz		ø = 20 MHz	
	n	N	n	N	n	N	n	N	n	N	n	N
110	3	70	—	—								
250	2	124	2	249	3	124	—	—	3	249		
500	1	249	2	124	2	249	—	—	3	124	—	—
1 k	1	124	1	249	2	124	—	—	2	249	—	—
2.5 k	0	199	1	99	1	199	1	249	2	99	2	124
5 k	0	99	0	199	1	99	1	124	1	199	1	249
10 k	0	49	0	99	0	199	0	249	1	99	1	124
25 k	0	19	0	39	0	79	0	99	0	159	0	199
50 k	0	9	0	19	0	39	0	49	0	79	0	99
100 k	0	4	0	9	0	19	0	24	0	39	0	49
250 k	0	1	0	3	0	7	0	9	0	15	0	19
500 k	0	0*	0	1	0	3	0	4	0	7	0	9
1 M			0	0*	0	1	—	—	0	3	0	4
2.5 M					—	—	0	0*	—	—	0	1
5 M									—	—	0	0*

Note: As far as possible, the setting should be made so that the error is no more than 1%.

Legend

Blank : Cannot be set.

— : Can be set, but there will be a degree of error.

* : Continuous transfer is not possible.

The BRR setting is found from the following formulas.

Asynchronous mode:

$$N = \frac{\phi}{64 \times 2^{2n-1} \times B} \times 10^6 - 1$$

Clocked synchronous mode:

$$N = \frac{\phi}{8 \times 2^{2n-1} \times B} \times 10^6 - 1$$

Where B: Bit rate (bit/s)

N: BRR setting for baud rate generator ($0 \leq N \leq 255$)

ϕ : Operating frequency (MHz)

n: Baud rate generator input clock ($n = 0$ to 3)

(See the table below for the relation between n and the clock.)

n	Clock	SMR Setting	
		CKS1	CKS0
0	ϕ	0	0
1	$\phi/4$	0	1
2	$\phi/16$	1	0
3	$\phi/64$	1	1

The bit rate error in asynchronous mode is found from the following formula:

$$\text{Error (\%)} = \left\{ \frac{\phi \times 10^6}{(N + 1) \times B \times 64 \times 2^{2n-1}} - 1 \right\} \times 100$$

Table 12-5 shows the maximum bit rate for each frequency in asynchronous mode. Tables 12-6 and 12-7 show the maximum bit rates with external clock input.

Table 12-5 Maximum Bit Rate for Each Frequency (Asynchronous Mode)

ø (MHz)	Maximum Bit Rate (bit/s)	n	N
2	62500	0	0
2.097152	65536	0	0
2.4576	76800	0	0
3	93750	0	0
3.6864	115200	0	0
4	125000	0	0
4.9152	153600	0	0
5	156250	0	0
6	187500	0	0
6.144	192000	0	0
7.3728	230400	0	0
8	250000	0	0
9.8304	307200	0	0
10	312500	0	0
12	375000	0	0
12.288	384000	0	0
14	437500	0	0
14.7456	460800	0	0
16	500000	0	0
17.2032	537600	0	0
18	562500	0	0
19.6608	614400	0	0
20	625000	0	0

Table 12-6 Maximum Bit Rate with External Clock Input (Asynchronous Mode)

ø (MHz)	External Input Clock (MHz)	Maximum Bit Rate (bit/s)
2	0.5000	31250
2.097152	0.5243	32768
2.4576	0.6144	38400
3	0.7500	46875
3.6864	0.9216	57600
4	1.0000	62500
4.9152	1.2288	76800
5	1.2500	78125
6	1.5000	93750
6.144	1.5360	96000
7.3728	1.8432	115200
8	2.0000	125000
9.8304	2.4576	153600
10	2.5000	156250
12	3.0000	187500
12.288	3.0720	192000
14	3.5000	218750
14.7456	3.6864	230400
16	4.0000	250000
17.2032	4.3008	268800
18	4.5000	281250
19.6608	4.9152	307200
20	5.0000	312500

Table 12-7 Maximum Bit Rate with External Clock Input (Clocked Synchronous Mode)

ø (MHz)	External Input Clock (MHz)	Maximum Bit Rate (bit/s)
2	0.3333	333333.3
4	0.6667	666666.7
6	1.0000	1000000.0
8	1.3333	1333333.3
10	1.6667	1666666.7
12	2.0000	2000000.0
14	2.3333	2333333.3
16	2.6667	2666666.7
18	3.0000	3000000.0
20	3.3333	3333333.3

12.2.9 Smart Card Mode Register (SCMR)

Bit	:	7	6	5	4	3	2	1	0
		—	—	—	—	SDIR	SINV	—	SMIF
Initial value	:	1	1	1	1	0	0	1	0
R/W	:	—	—	—	—	R/W	R/W	—	R/W

SCMR selects LSB-first or MSB-first by means of bit SDIR. Except in the case of asynchronous mode 7-bit data, LSB-first or MSB-first can be selected regardless of the serial communication mode. The descriptions in this chapter refer to LSB-first transfer.

For details of the other bits in SCMR, see 13.2.1, Smart Card Mode Register (SCMR).

SCMR is initialized to HF2 by a reset, and in standby mode or module stop mode.

Bits 7 to 4—Reserved: Read-only bits, always read as 1.

Bit 3—Smart Card Data Transfer Direction (SDIR): Selects the serial/parallel conversion format.

This bit is valid when 8-bit data is used as the transmit/receive format.

Bit 3

SDIR	Description
0	TDR contents are transmitted LSB-first Receive data is stored in RDR LSB-first (Initial value)
1	TDR contents are transmitted MSB-first Receive data is stored in RDR MSB-first

Bit 2—Smart Card Data Invert (SINV): When the smart card interface operates as a normal SCI, 0 should be written in this bit.

Bit 1—Reserved: Read-only bit, always read as 1.

Bit 0—Smart Card Interface Mode Select (SMIF): When the smart card interface operates as a normal SCI, 0 should be written in this bit.

12.2.10 Module Stop Control Register (MSTPCR)

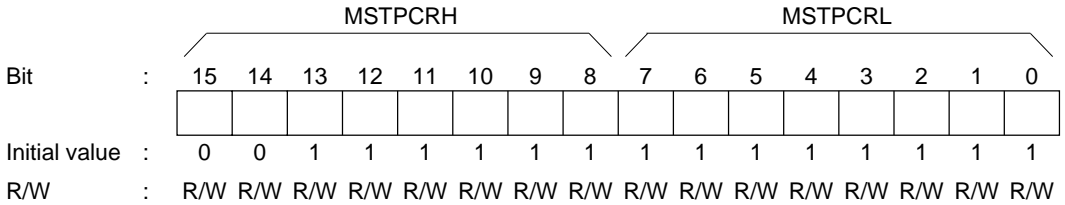

MSTPCR is a 16-bit readable/writable register that performs module stop mode control.

When the corresponding bit of bits MSTP7 to MSTP5 is set to 1, SCI operation stops at the end of the bus cycle and a transition is made to module stop mode. Registers cannot be read or written to in module stop mode. For details, see section 19.5, Module Stop Mode.

MSTPCR is initialized to H'3FFF by a reset and in hardware standby mode. It is not initialized in software standby mode.

Bit 7—Module Stop (MSTP7): Specifies the SCI channel 2 module stop mode.

Bit 7

MSTP7	Description
0	SCI channel 2 module stop mode cleared
1	SCI channel 2 module stop mode set (Initial value)

Bit 6—Module Stop (MSTP6): Specifies the SCI channel 1 module stop mode.

Bit 6

MSTP6	Description
0	SCI channel 1 module stop mode cleared
1	SCI channel 1 module stop mode set (Initial value)

Bit 5—Module Stop (MSTP5): Specifies the SCI channel 0 module stop mode.

Bit 5

MSTP5	Description
0	SCI channel 0 module stop mode cleared
1	SCI channel 0 module stop mode set (Initial value)

12.3 Operation

12.3.1 Overview

The SCI can carry out serial communication in two modes: asynchronous mode in which synchronization is achieved character by character, and clocked synchronous mode in which synchronization is achieved with clock pulses.

Selection of asynchronous or clocked synchronous mode and the transmission format is made using SMR as shown in table 12-8. The SCI clock is determined by a combination of the C/\bar{A} bit in SMR and the CKE1 and CKE0 bits in SCR, as shown in table 12-9.

Asynchronous Mode

- Data length: Choice of 7 or 8 bits
- Choice of parity addition, multiprocessor bit addition, and addition of 1 or 2 stop bits (the combination of these parameters determines the transfer format and character length)
- Detection of framing, parity, and overrun errors, and breaks, during reception
- Choice of internal or external clock as SCI clock source
 - When internal clock is selected:
The SCI operates on the baud rate generator clock and a clock with the same frequency as the bit rate can be output
 - When external clock is selected:
A clock with a frequency of 16 times the bit rate must be input (the on-chip baud rate generator is not used)

Clocked Synchronous Mode

- Transfer format: Fixed 8-bit data
- Detection of overrun errors during reception
- Choice of internal or external clock as SCI clock source
 - When internal clock is selected:
The SCI operates on the baud rate generator clock and a serial clock is output off-chip
 - When external clock is selected:
The on-chip baud rate generator is not used, and the SCI operates on the input serial clock

Table 12-8 SMR Settings and Serial Transfer Format Selection

SMR Settings						SCI Transfer Format			
Bit 7	Bit 6	Bit 2	Bit 5	Bit 3	Mode	Data Length	Multi Processor Bit	Parity Bit	Stop Bit Length
C/ \bar{A}	CHR	MP	PE	STOP					
0	0	0	0	0	Asynchronous mode	8-bit data	No	No	1 bit
				1					2 bits
				0					1 bit
				1					2 bits
	1	0	0	0	0	7-bit data	7-bit data	No	1 bit
					1				2 bits
					1				1 bit
					1				2 bits
0	1	—	0	0	Asynchronous mode (multi-processor format)	8-bit data	Yes	No	1 bit
				1					2 bits
				1					1 bit
				1					2 bits
1	—	—	—	—	Clocked synchronous mode	8-bit data	No	None	

Table 12-9 SMR and SCR Settings and SCI Clock Source Selection

SMR	SCR Setting			SCI Transmit/Receive Clock	
Bit 7	Bit 1	Bit 0	Mode	Clock Source	SCK Pin Function
C/ \bar{A}	CKE1	CKE0			
0	0	0	Asynchronous mode	Internal	SCI does not use SCK pin
		1			Outputs clock with same frequency as bit rate
	1	0	External	Inputs clock with frequency of 16 times the bit rate	
		1			
1	0	0	Clocked synchronous mode	Internal	Outputs serial clock
		1			
	1	0	External	Inputs serial clock	
		1			

12.3.2 Operation in Asynchronous Mode

In asynchronous mode, characters are sent or received, each preceded by a start bit indicating the start of communication and one or two stop bits indicating the end of communication. Serial communication is thus carried out with synchronization established on a character-by-character basis.

Inside the SCI, the transmitter and receiver are independent units, enabling full-duplex communication. Both the transmitter and the receiver also have a double-buffered structure, so that data can be read or written during transmission or reception, enabling continuous data transfer.

Figure 12-2 shows the general format for asynchronous serial communication.

In asynchronous serial communication, the transmission line is usually held in the mark state (high level). The SCI monitors the transmission line, and when it goes to the space state (low level), recognizes a start bit and starts serial communication.

One serial communication character consists of a start bit (low level), followed by data (in LSB-first order), a parity bit (high or low level), and finally one or two stop bits (high level).

In asynchronous mode, the SCI performs synchronization at the falling edge of the start bit in reception. The SCI samples the data on the 8th pulse of a clock with a frequency of 16 times the length of one bit, so that the transfer data is latched at the center of each bit.

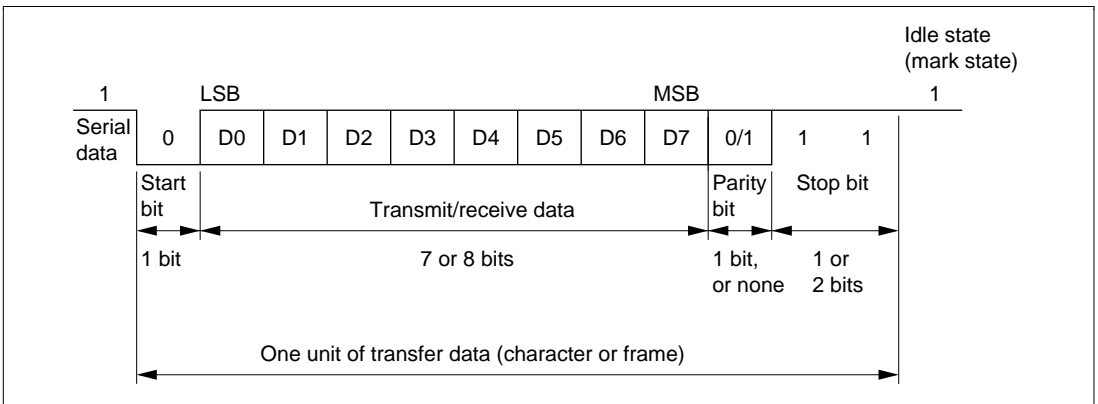

**Figure 12-2 Data Format in Asynchronous Communication
(Example with 8-Bit Data, Parity, Two Stop Bits)**

Data Transfer Format: Table 12-10 shows the data transfer formats that can be used in asynchronous mode. Any of 12 transfer formats can be selected according to the SMR setting.

Table 12-10 Serial Transfer Formats (Asynchronous Mode)

SMR Settings				Serial Transfer Format and Frame Length												
CHR	PE	MP	STOP	1	2	3	4	5	6	7	8	9	10	11	12	
0	0	0	0	S	8-bit data								STOP			
0	0	0	1	S	8-bit data								STOP	STOP		
0	1	0	0	S	8-bit data								P	STOP		
0	1	0	1	S	8-bit data								P	STOP	STOP	
1	0	0	0	S	7-bit data							STOP				
1	0	0	1	S	7-bit data							STOP	STOP			
1	1	0	0	S	7-bit data							P	STOP			
1	1	0	1	S	7-bit data							P	STOP	STOP		
0	—	1	0	S	8-bit data								MPB	STOP		
0	—	1	1	S	8-bit data								MPB	STOP	STOP	
1	—	1	0	S	7-bit data							MPB	STOP			
1	—	1	1	S	7-bit data							MPB	STOP	STOP		

Legend

- S : Start bit
- STOP : Stop bit
- P : Parity bit
- MPB : Multiprocessor bit

Clock: Either an internal clock generated by the on-chip baud rate generator or an external clock input at the SCK pin can be selected as the SCI's serial clock, according to the setting of the C/\bar{A} bit in SMR and the CKE1 and CKE0 bits in SCR. For details of SCI clock source selection, see table 12-9.

When an external clock is input at the SCK pin, the clock frequency should be 16 times the bit rate used.

When the SCI is operated on an internal clock, the clock can be output from the SCK pin. The frequency of the clock output in this case is equal to the bit rate, and the phase is such that the rising edge of the clock is in the middle of the transmit data, as shown in figure 12-3.

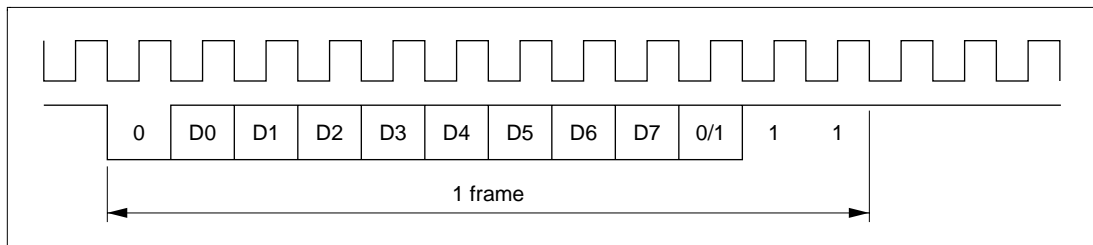

Figure 12-3 Relation between Output Clock and Transfer Data Phase (Asynchronous Mode)

Data Transfer Operations:

- SCI initialization (asynchronous mode)

Before transmitting and receiving data, you should first clear the TE and RE bits in SCR to 0, then initialize the SCI as described below.

When the operating mode, transfer format, etc., is changed, the TE and RE bits must be cleared to 0 before making the change using the following procedure. When the TE bit is cleared to 0, the TDRE flag is set to 1 and TSR is initialized. Note that clearing the RE bit to 0 does not change the contents of the RDRF, PER, FER, and ORER flags, or the contents of RDR.

When an external clock is used the clock should not be stopped during operation, including initialization, since operation is uncertain.

Figure 12-4 shows a sample SCI initialization flowchart.

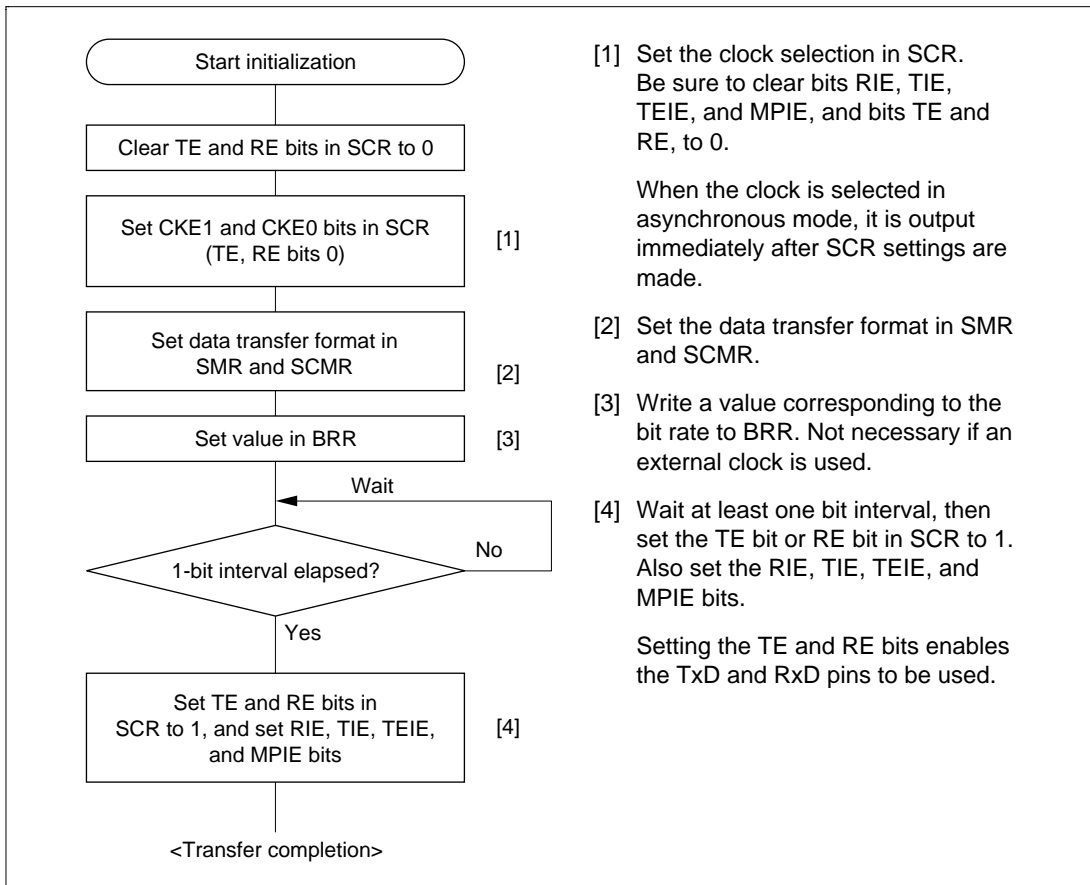

Figure 12-4 Sample SCI Initialization Flowchart

- Serial data transmission (asynchronous mode)

Figure 12-5 shows a sample flowchart for serial transmission.

The following procedure should be used for serial data transmission.

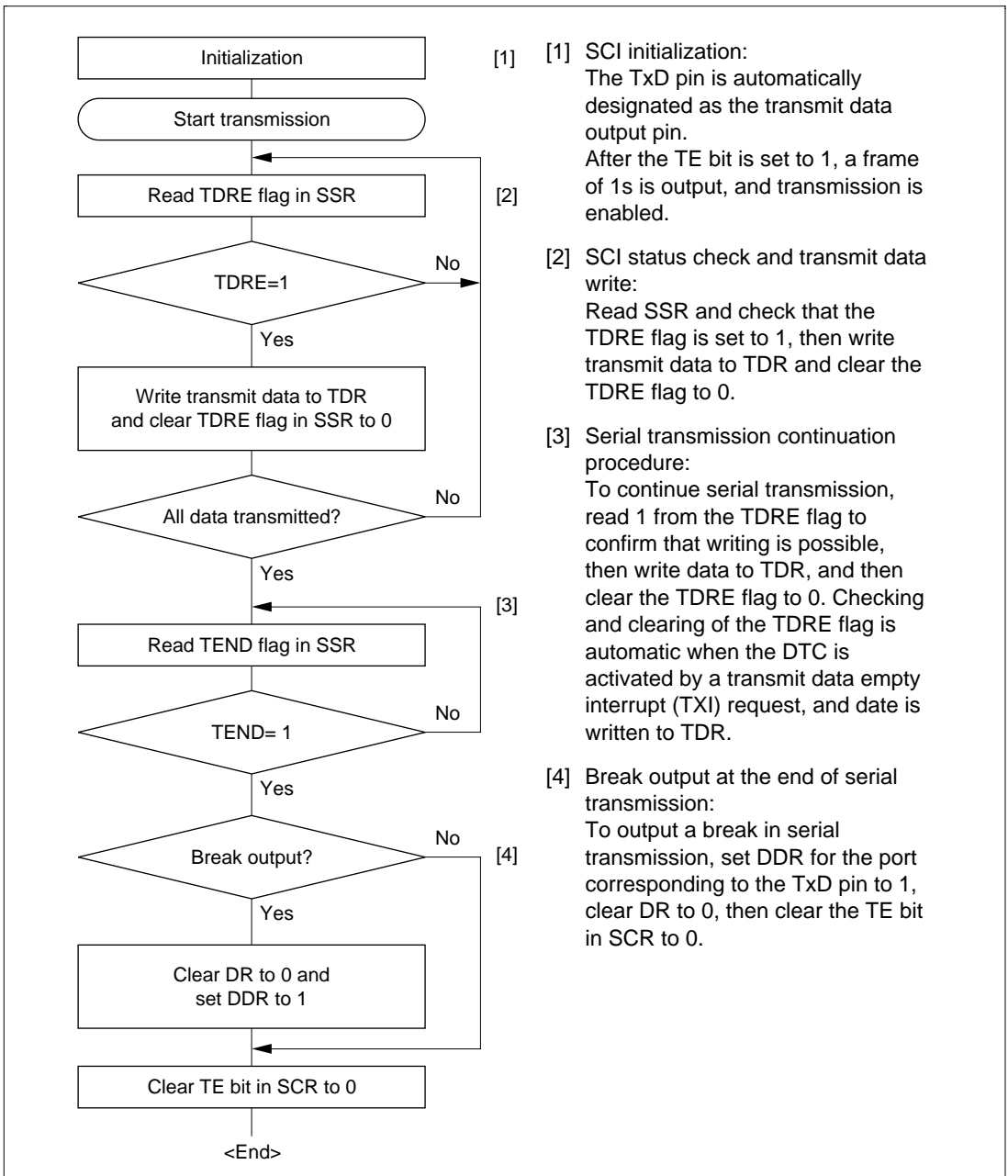

Figure 12-5 Sample Serial Transmission Flowchart

In serial transmission, the SCI operates as described below.

[1] The SCI monitors the TDRE flag in SSR, and if it is 0, recognizes that data has been written to TDR, and transfers the data from TDR to TSR.

[2] After transferring data from TDR to TSR, the SCI sets the TDRE flag to 1 and starts transmission.

If the TIE bit is set to 1 at this time, a transmit data empty interrupt (TXI) is generated.

The serial transmit data is sent from the TxD pin in the following order.

[a] Start bit:

One 0-bit is output.

[b] Transmit data:

8-bit or 7-bit data is output in LSB-first order.

[c] Parity bit or multiprocessor bit:

One parity bit (even or odd parity), or one multiprocessor bit is output.

A format in which neither a parity bit nor a multiprocessor bit is output can also be selected.

[d] Stop bit(s):

One or two 1-bits (stop bits) are output.

[e] Mark state:

1 is output continuously until the start bit that starts the next transmission is sent.

[3] The SCI checks the TDRE flag at the timing for sending the stop bit.

If the TDRE flag is cleared to 0, the data is transferred from TDR to TSR, the stop bit is sent, and then serial transmission of the next frame is started.

If the TDRE flag is set to 1, the TEND flag in SSR is set to 1, the stop bit is sent, and then the “mark state” is entered in which 1 is output continuously. If the TEIE bit in SCR is set to 1 at this time, a TEI interrupt request is generated.

Figure 12-6 shows an example of the operation for transmission in asynchronous mode.

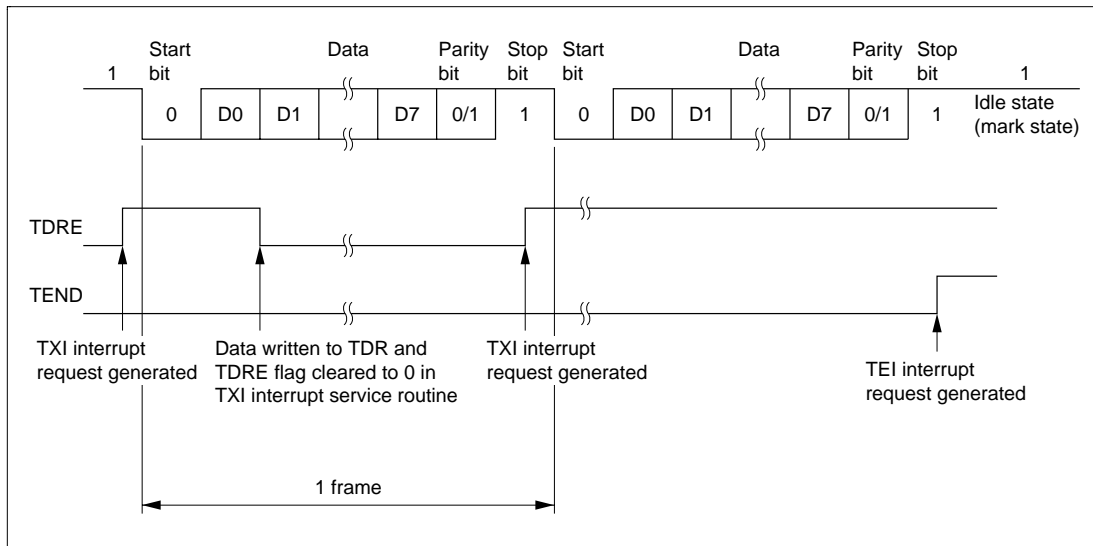

**Figure 12-6 Example of Operation in Transmission in Asynchronous Mode
(Example with 8-Bit Data, Parity, One Stop Bit)**

- Serial data reception (asynchronous mode)

Figure 12-7 shows a sample flowchart for serial reception.

The following procedure should be used for serial data reception.

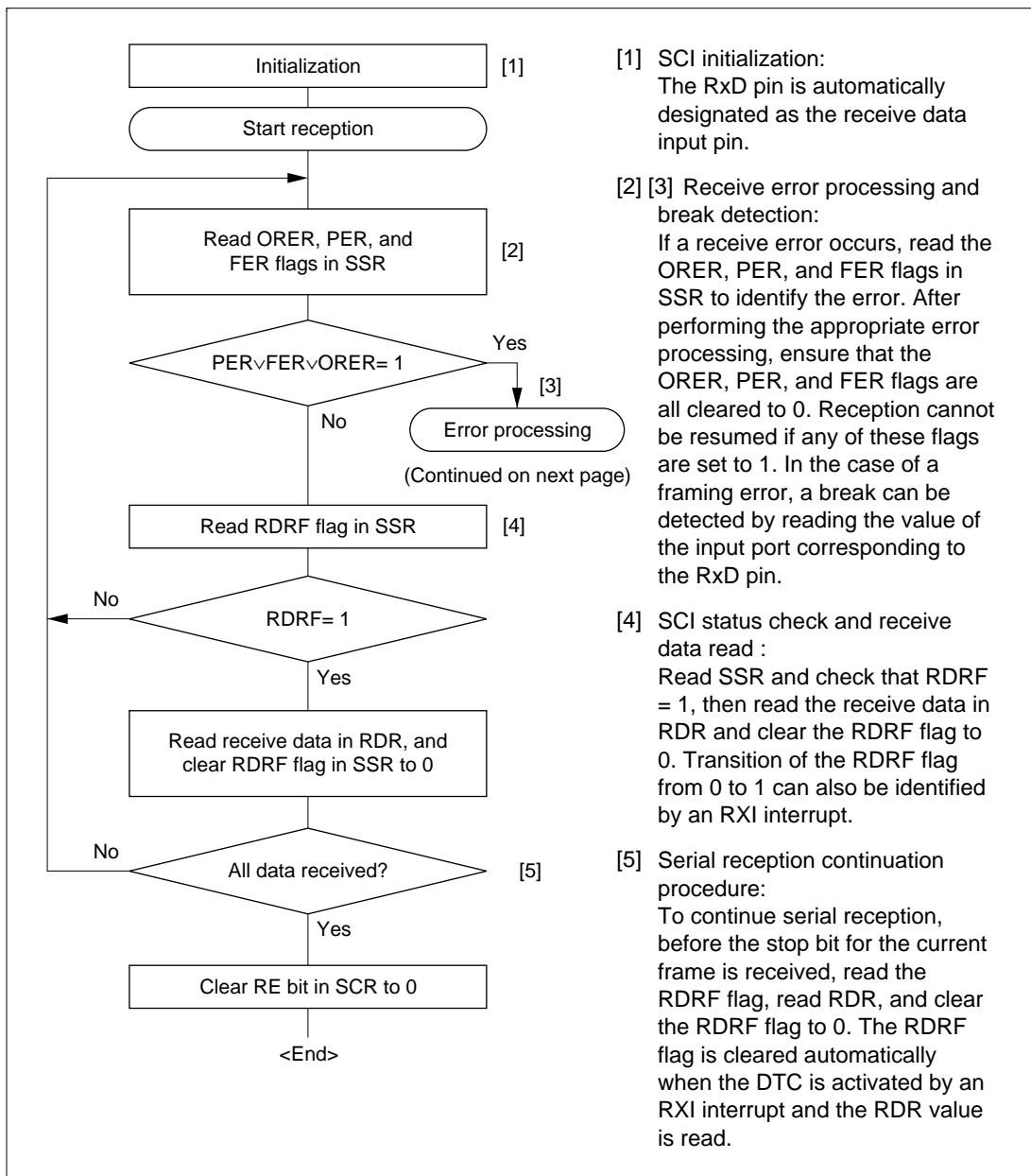

Figure 12-7 Sample Serial Reception Data Flowchart

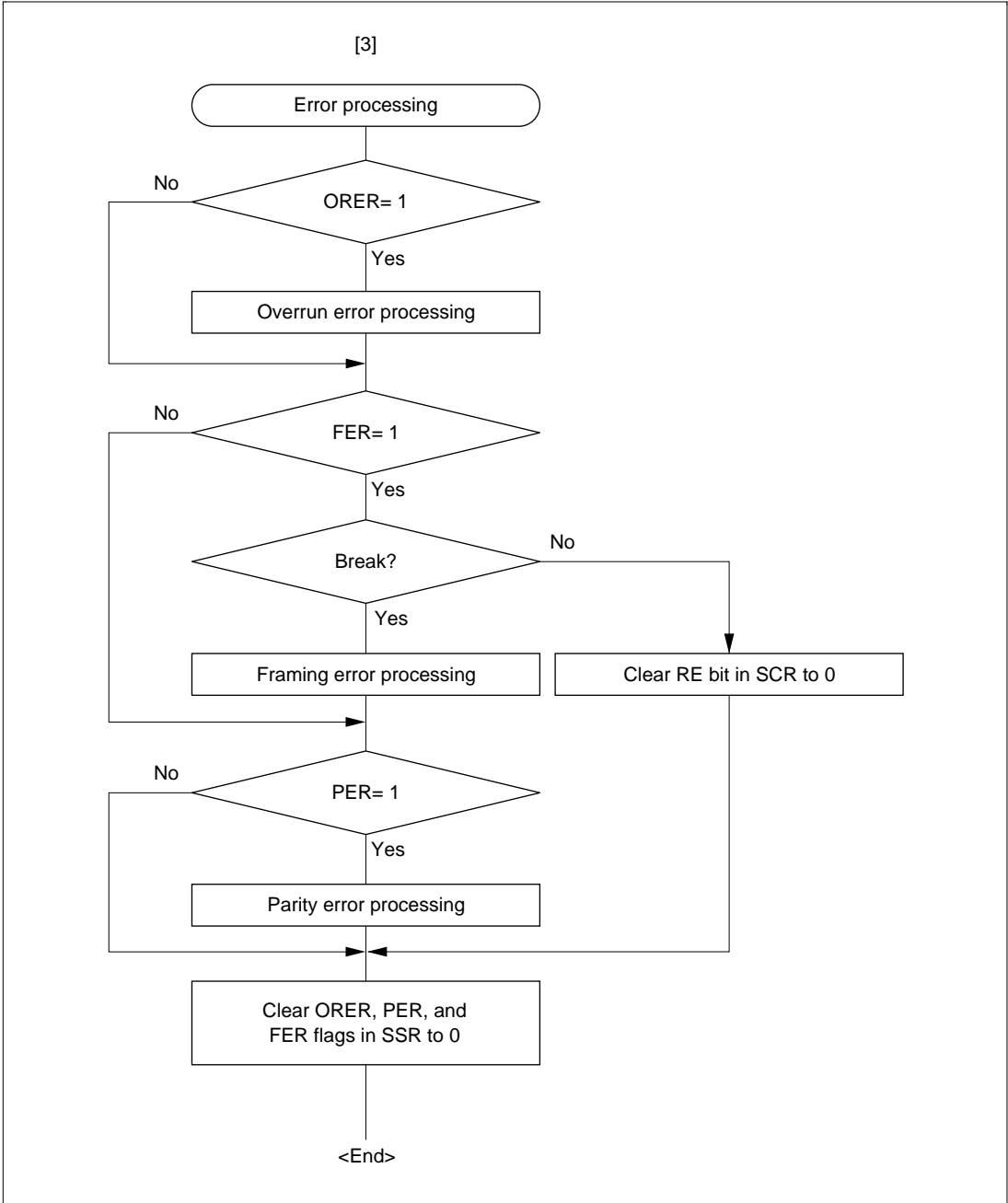

Figure 12-7 Sample Serial Reception Data Flowchart (cont)

In serial reception, the SCI operates as described below.

- [1] The SCI monitors the transmission line, and if a 0 stop bit is detected, performs internal synchronization and starts reception.
- [2] The received data is stored in RSR in LSB-to-MSB order.
- [3] The parity bit and stop bit are received.
After receiving these bits, the SCI carries out the following checks.

[a] Parity check:

The SCI checks whether the number of 1 bits in the receive data agrees with the parity (even or odd) set in the O/\bar{E} bit in SMR.

[b] Stop bit check:

The SCI checks whether the stop bit is 1.
If there are two stop bits, only the first is checked.

[c] Status check:

The SCI checks whether the RDRF flag is 0, indicating that the receive data can be transferred from RSR to RDR.

If all the above checks are passed, the RDRF flag is set to 1, and the receive data is stored in RDR.

If a receive error* is detected in the error check, the operation is as shown in table 12-11.

Note: * Subsequent receive operations cannot be performed when a receive error has occurred.
Also note that the RDRF flag is not set to 1 in reception, and so the error flags must be cleared to 0.

- [4] If the RIE bit in SCR is set to 1 when the RDRF flag changes to 1, a receive data full interrupt (RXI) request is generated.
Also, if the RIE bit in SCR is set to 1 when the ORER, PER, or FER flag changes to 1, a receive error interrupt (ERI) request is generated.

Table 12-11 Receive Errors and Conditions for Occurrence

Receive Error	Abbreviation	Occurrence Condition	Data Transfer
Overrun error	ORER	When the next data reception is completed while the RDRF flag in SSR is set to 1	Receive data is not transferred from RSR to RDR.
Framing error	FER	When the stop bit is 0	Receive data is transferred from RSR to RDR.
Parity error	PER	When the received data differs from the parity (even or odd) set in SMR	Receive data is transferred from RSR to RDR.

Figure 12-8 shows an example of the operation for reception in asynchronous mode.

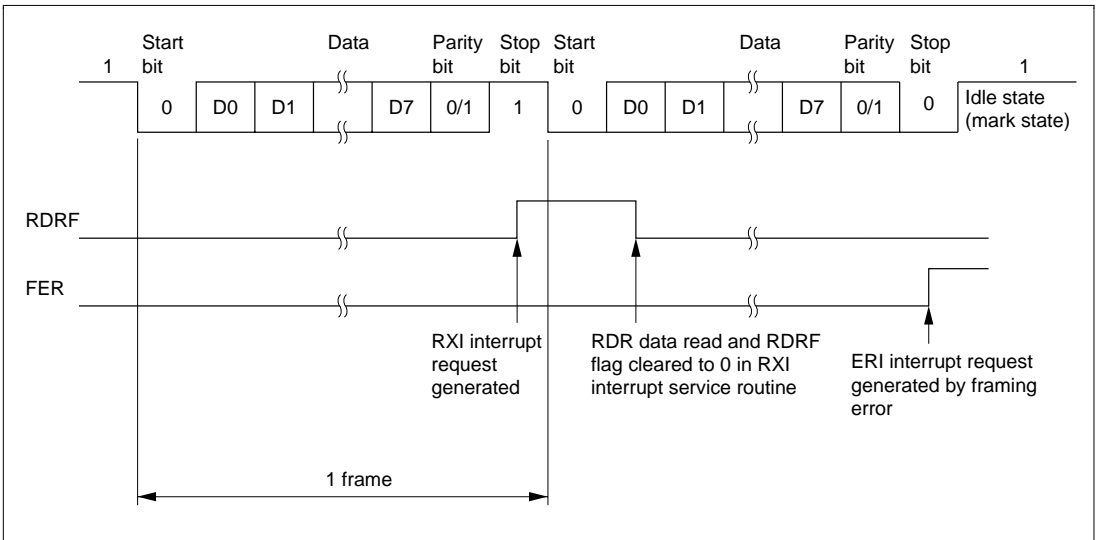

**Figure 12-8 Example of SCI Operation in Reception
(Example with 8-Bit Data, Parity, One Stop Bit)**

12.3.3 Multiprocessor Communication Function

The multiprocessor communication function performs serial communication using the multiprocessor format, in which a multiprocessor bit is added to the transfer data, in asynchronous mode. Use of this function enables data transfer to be performed among a number of processors sharing transmission lines.

When multiprocessor communication is carried out, each receiving station is addressed by a unique ID code.

The serial communication cycle consists of two component cycles: an ID transmission cycle which specifies the receiving station, and a data transmission cycle. The multiprocessor bit is used to differentiate between the ID transmission cycle and the data transmission cycle.

The transmitting station first sends the ID of the receiving station with which it wants to perform serial communication as data with a 1 multiprocessor bit added. It then sends transmit data as data with a 0 multiprocessor bit added.

The receiving station skips the data until data with a 1 multiprocessor bit is sent.

When data with a 1 multiprocessor bit is received, the receiving station compares that data with its own ID. The station whose ID matches then receives the data sent next. Stations whose ID does not match continue to skip the data until data with a 1 multiprocessor bit is again received. In this way, data communication is carried out among a number of processors.

Figure 12-9 shows an example of inter-processor communication using the multiprocessor format.

Data Transfer Format: There are four data transfer formats.

When the multiprocessor format is specified, the parity bit specification is invalid.

For details, see table 12-10.

Clock: See the section on asynchronous mode.

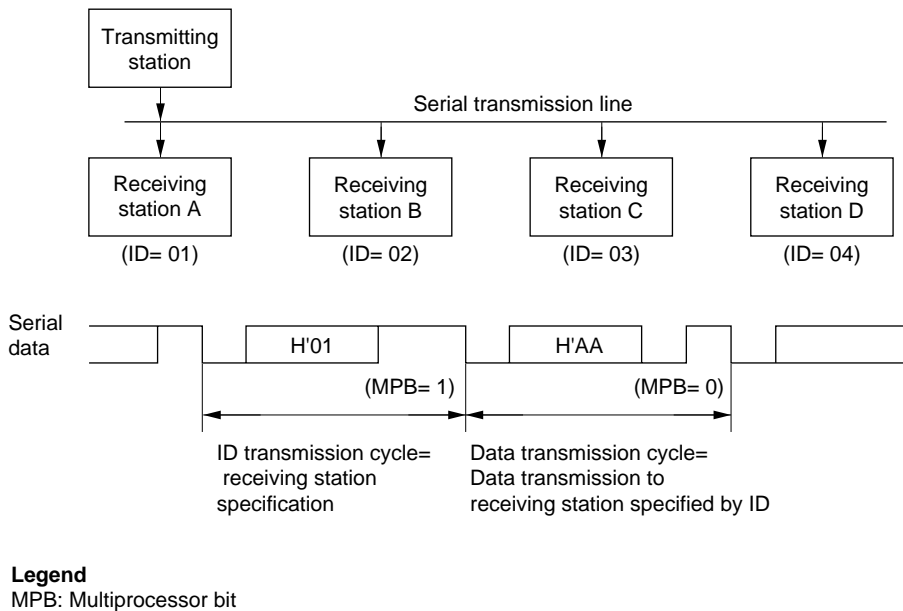
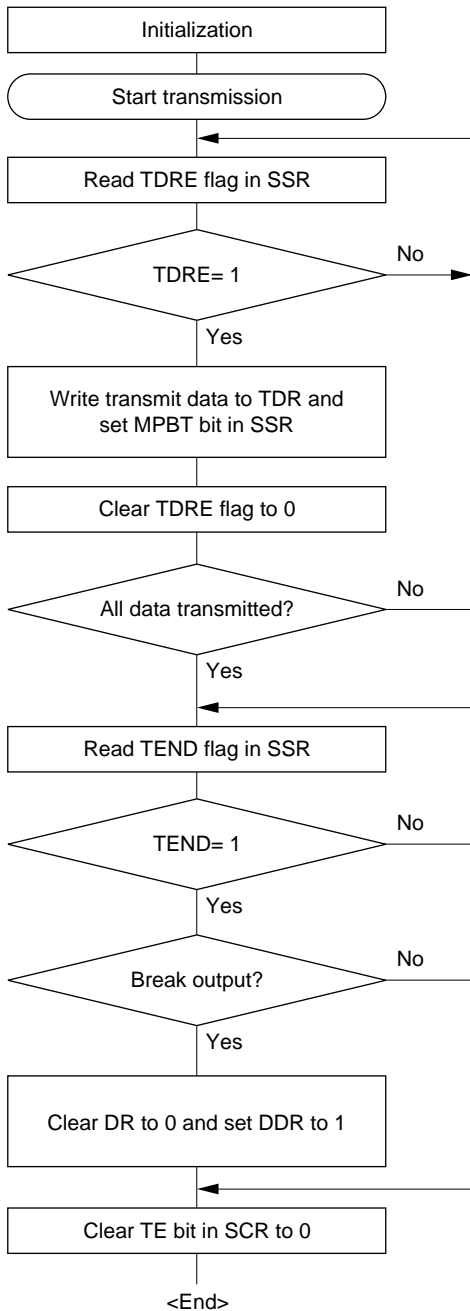

Figure 12-9 Example of Inter-Processor Communication Using Multiprocessor Format (Transmission of Data H'AA to Receiving Station A)

Data Transfer Operations:

- Multiprocessor serial data transmission

Figure 12-10 shows a sample flowchart for multiprocessor serial data transmission. The following procedure should be used for multiprocessor serial data transmission.



- [1] [1] SCI initialization:
The TxD pin is automatically designated as the transmit data output pin.
After the TE bit is set to 1, a frame of 1s is output, and transmission is enabled.
- [2] [2] SCI status check and transmit data write:
Read SSR and check that the TDRE flag is set to 1, then write transmit data to TDR. Set the MPBT bit in SSR to 0 or 1. Finally, clear the TDRE flag to 0.
- [3] [3] Serial transmission continuation procedure:
To continue serial transmission, be sure to read 1 from the TDRE flag to confirm that writing is possible, then write data to TDR, and then clear the TDRE flag to 0. Checking and clearing of the TDRE flag is automatic when the DTC is activated by a transmit data empty interrupt (TXI) request, and data is written to TDR.
- [4] [4] Break output at the end of serial transmission:
To output a break in serial transmission, set the port DDR to 1, clear DR to 0, then clear the TE bit in SCR to 0.

Figure 12-10 Sample Multiprocessor Serial Transmission Flowchart

In serial transmission, the SCI operates as described below.

[1] The SCI monitors the TDRE flag in SSR, and if it is 0, recognizes that data has been written to TDR, and transfers the data from TDR to TSR.

[2] After transferring data from TDR to TSR, the SCI sets the TDRE flag to 1 and starts transmission.

If the TIE bit is set to 1 at this time, a transmit data empty interrupt (TXI) is generated.

The serial transmit data is sent from the TxD pin in the following order.

[a] Start bit:

One 0-bit is output.

[b] Transmit data:

8-bit or 7-bit data is output in LSB-first order.

[c] Multiprocessor bit

One multiprocessor bit (MPBT value) is output.

[d] Stop bit(s):

One or two 1-bits (stop bits) are output.

[e] Mark state:

1 is output continuously until the start bit that starts the next transmission is sent.

[3] The SCI checks the TDRE flag at the timing for sending the stop bit.

If the TDRE flag is cleared to 0, data is transferred from TDR to TSR, the stop bit is sent, and then serial transmission of the next frame is started.

If the TDRE flag is set to 1, the TEND flag in SSR is set to 1, the stop bit is sent, and then the mark state is entered in which 1 is output continuously. If the TEIE bit in SCR is set to 1 at this time, a transmission end interrupt (TEI) request is generated.

Figure 12-11 shows an example of SCI operation for transmission using the multiprocessor format.

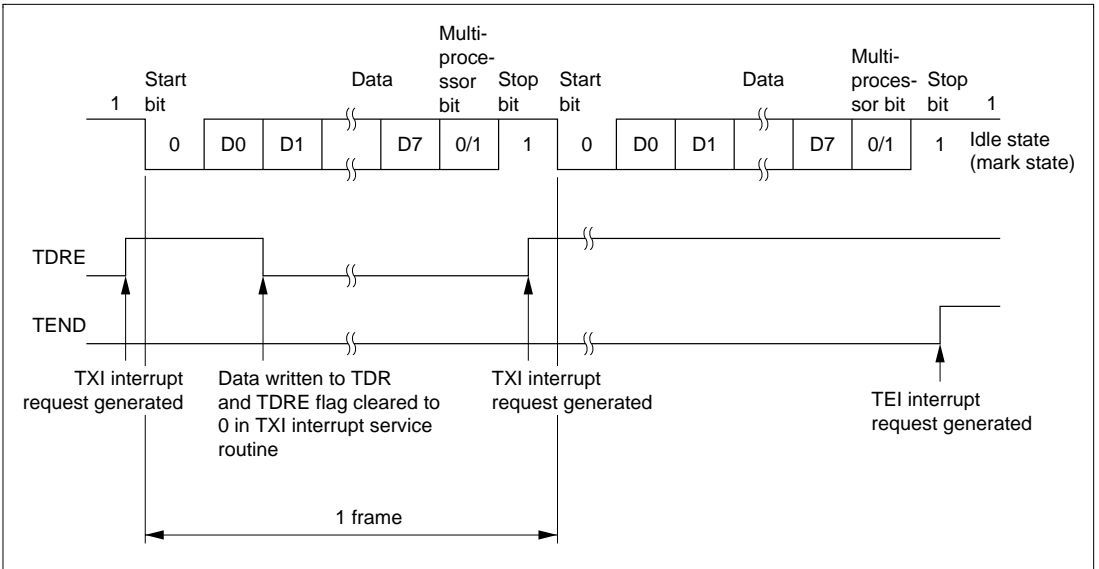
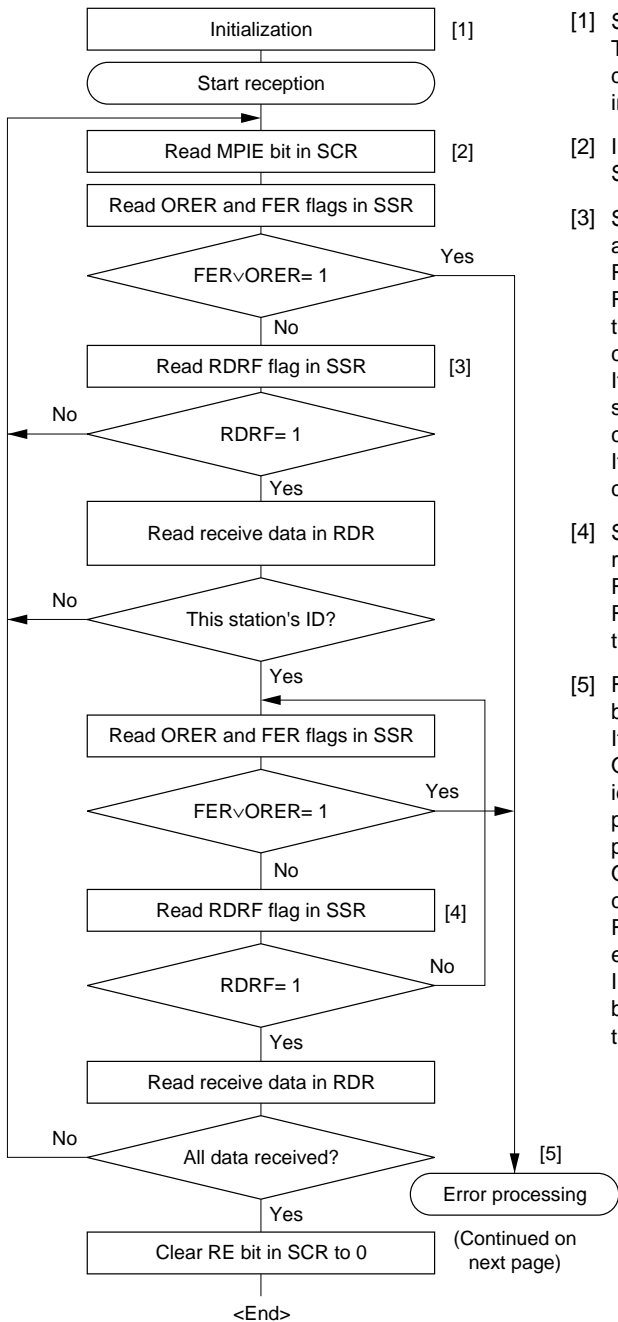

**Figure 12-11 Example of SCI Operation in Transmission
(Example with 8-Bit Data, Multiprocessor Bit, One Stop Bit)**

- Multiprocessor serial data reception

Figure 12-12 shows a sample flowchart for multiprocessor serial reception.

The following procedure should be used for multiprocessor serial data reception.



- [1] SCI initialization:
The RxD pin is automatically designated as the receive data input pin.
- [2] ID reception cycle:
Set the MPIE bit in SCR to 1.
- [3] SCI status check, ID reception and comparison:
Read SSR and check that the RDRF flag is set to 1, then read the receive data in RDR and compare it with this station's ID. If the data is not this station's ID, set the MPIE bit to 1 again, and clear the RDRF flag to 0. If the data is this station's ID, clear the RDRF flag to 0.
- [4] SCI status check and data reception:
Read SSR and check that the RDRF flag is set to 1, then read the data in RDR.
- [5] Receive error processing and break detection:
If a receive error occurs, read the ORER and FER flags in SSR to identify the error. After performing the appropriate error processing, ensure that the ORER and FER flags are all cleared to 0. Reception cannot be resumed if either of these flags is set to 1. In the case of a framing error, a break can be detected by reading the RxD pin value.

[5] Error processing
(Continued on next page)

Figure 12-12 Sample Multiprocessor Serial Reception Flowchart

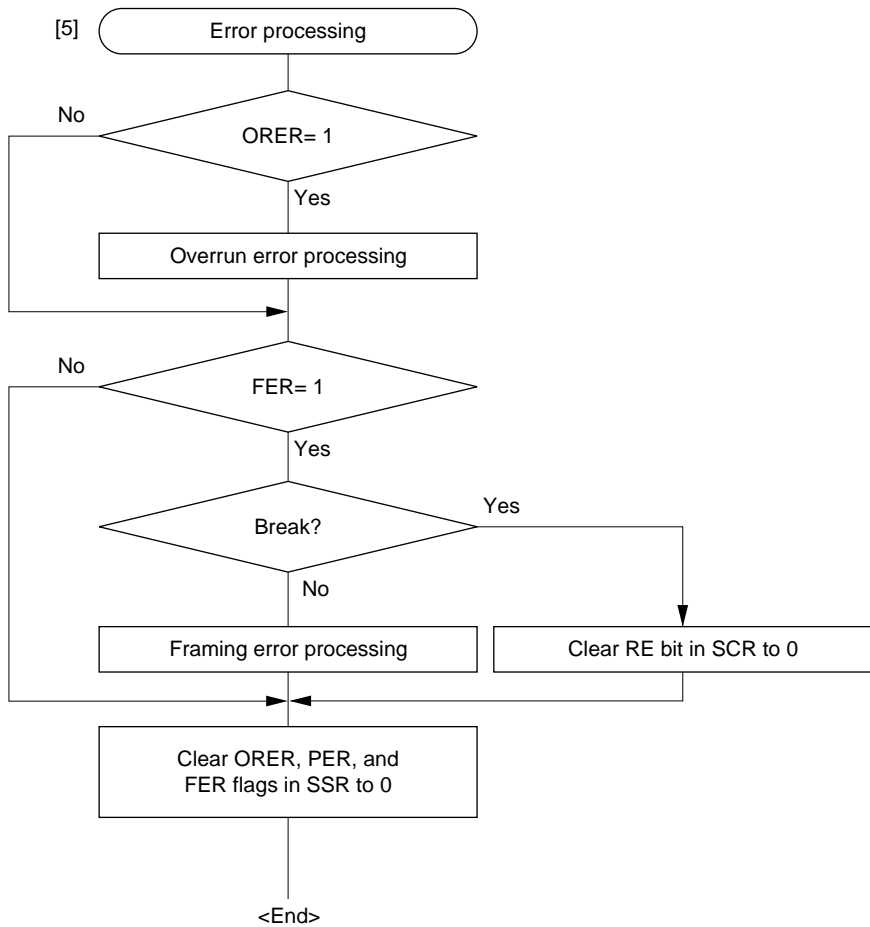
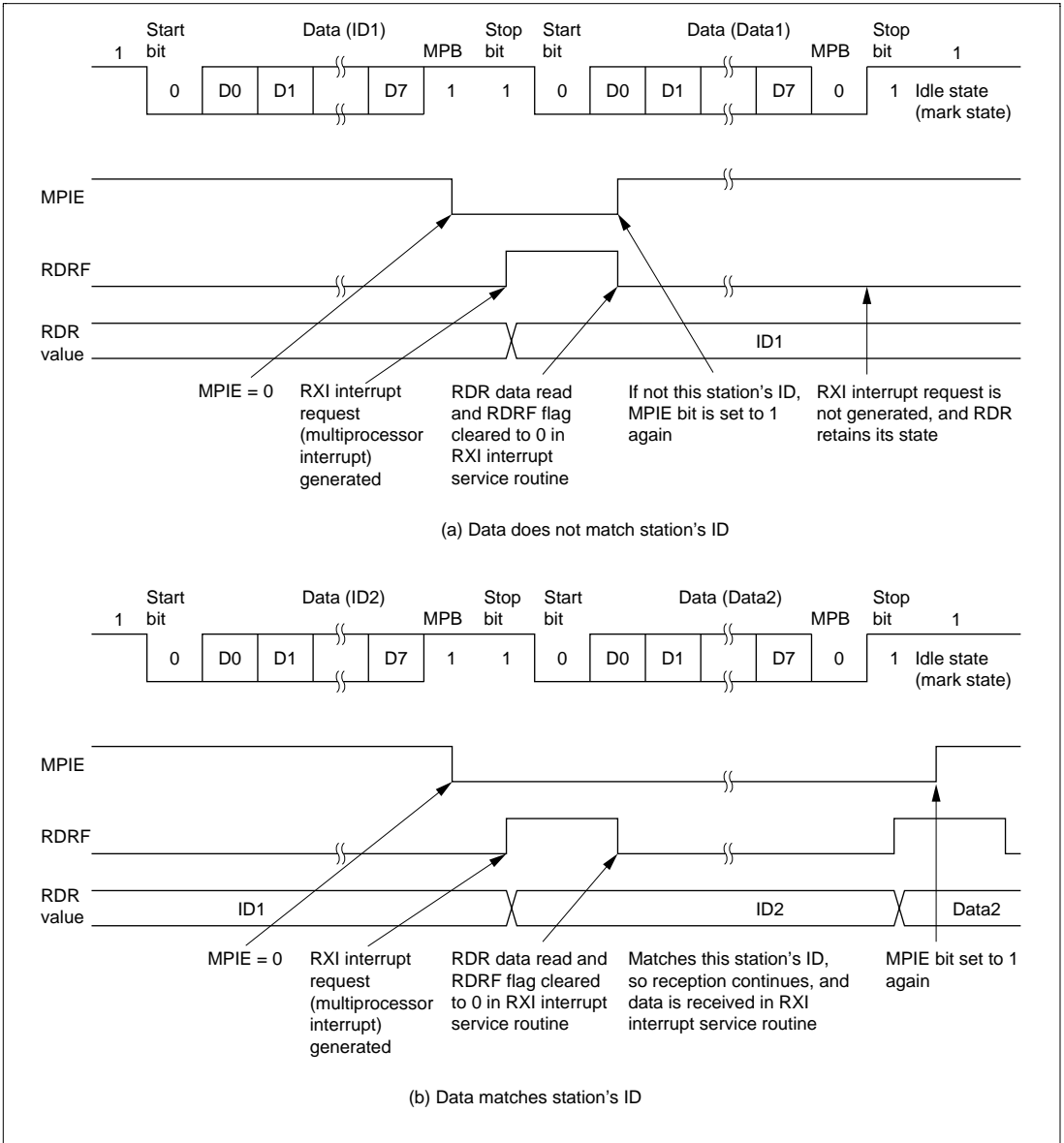

Figure 12-12 Sample Multiprocessor Serial Reception Flowchart (cont)

Figure 12-13 shows an example of SCI operation for multiprocessor format reception.



**Figure 12-13 Example of SCI Operation in Reception
(Example with 8-Bit Data, Multiprocessor Bit, One Stop Bit)**

12.3.4 Operation in Clocked Synchronous Mode

In clocked synchronous mode, data is transmitted or received in synchronization with clock pulses, making it suitable for high-speed serial communication.

Inside the SCI, the transmitter and receiver are independent units, enabling full-duplex communication by use of a common clock. Both the transmitter and the receiver also have a double-buffered structure, so that data can be read or written during transmission or reception, enabling continuous data transfer.

Figure 12-14 shows the general format for clocked synchronous serial communication.

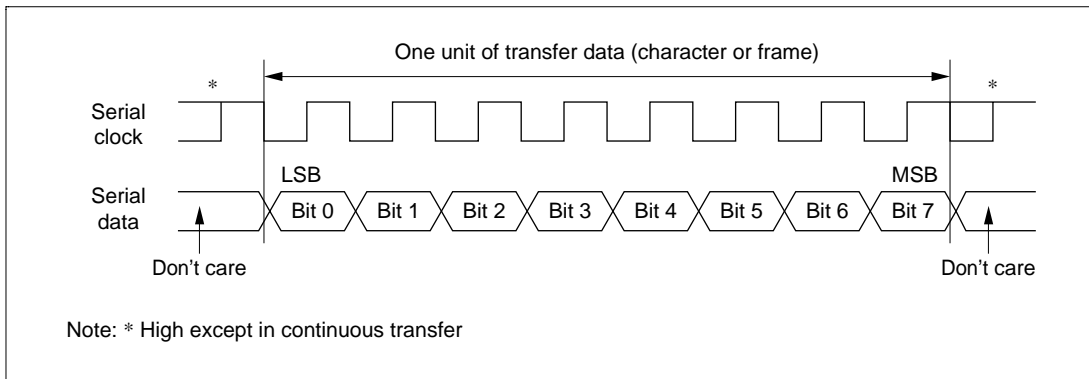

Figure 12-14 Data Format in Synchronous Communication

In clocked synchronous serial communication, data on the transmission line is output from one falling edge of the serial clock to the next. Data confirmation is guaranteed at the rising edge of the serial clock.

In clocked serial communication, one character consists of data output starting with the LSB and ending with the MSB. After the MSB is output, the transmission line holds the MSB state.

In clocked synchronous mode, the SCI receives data in synchronization with the rising edge of the serial clock.

Data Transfer Format: A fixed 8-bit data format is used.

No parity or multiprocessor bits are added.

Clock: Either an internal clock generated by the on-chip baud rate generator or an external serial clock input at the SCK pin can be selected, according to the setting of the C/\bar{A} bit in SMR and the CKE1 and CKE0 bits in SCR. For details of SCI clock source selection, see table 12-9.

When the SCI is operated on an internal clock, the serial clock is output from the SCK pin.

Eight serial clock pulses are output in the transfer of one character, and when no transfer is performed the clock is fixed high. When only receive operations are performed, however, the serial clock is output until an overrun error occurs or the RE bit is cleared to 0. If you want to perform receive operations in units of one character, you should select an external clock as the clock source.

Data Transfer Operations:

- SCI initialization (clocked synchronous mode)

Before transmitting and receiving data, you should first clear the TE and RE bits in SCR to 0, then initialize the SCI as described below.

When the operating mode, transfer format, etc., is changed, the TE and RE bits must be cleared to 0 before making the change using the following procedure. When the TE bit is cleared to 0, the TDRE flag is set to 1 and TSR is initialized. Note that clearing the RE bit to 0 does not change the contents of the RDRF, PER, FER, and ORER flags, or the contents of RDR.

Figure 12-15 shows a sample SCI initialization flowchart.

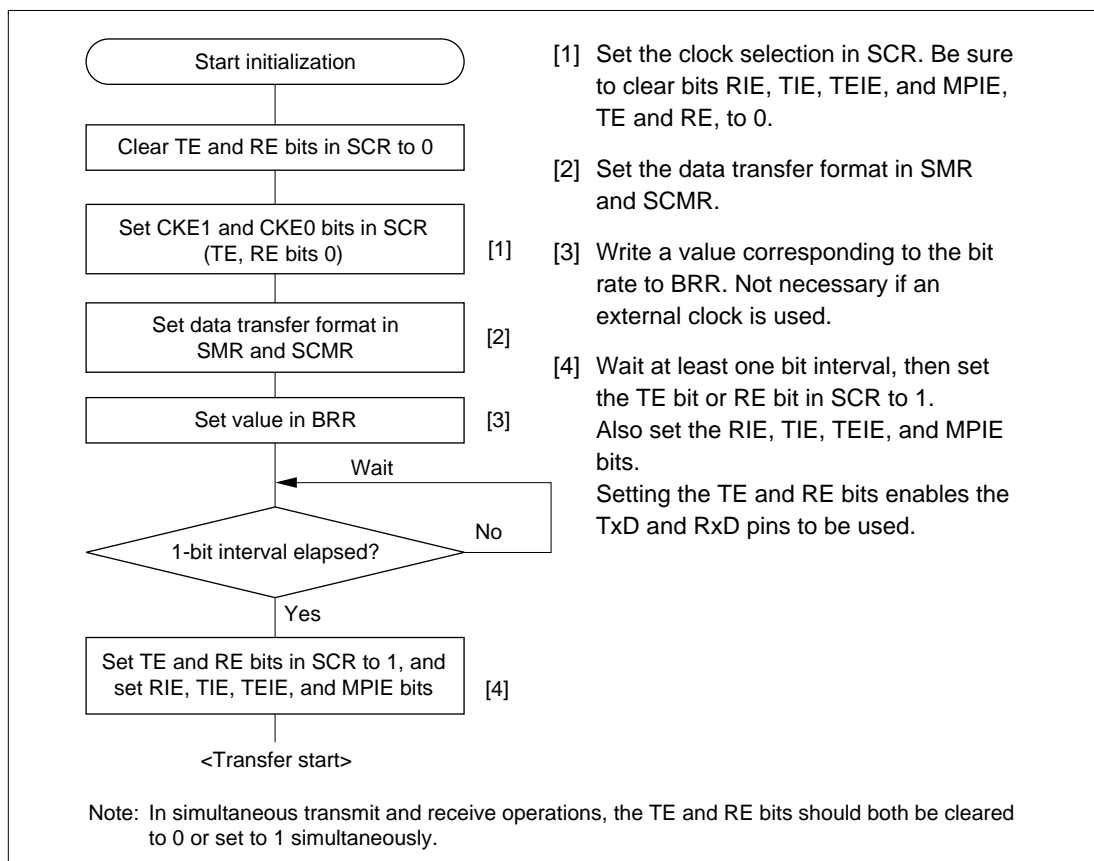

Figure 12-15 Sample SCI Initialization Flowchart

- Serial data transmission (clocked synchronous mode)

Figure 12-16 shows a sample flowchart for serial transmission.

The following procedure should be used for serial data transmission.

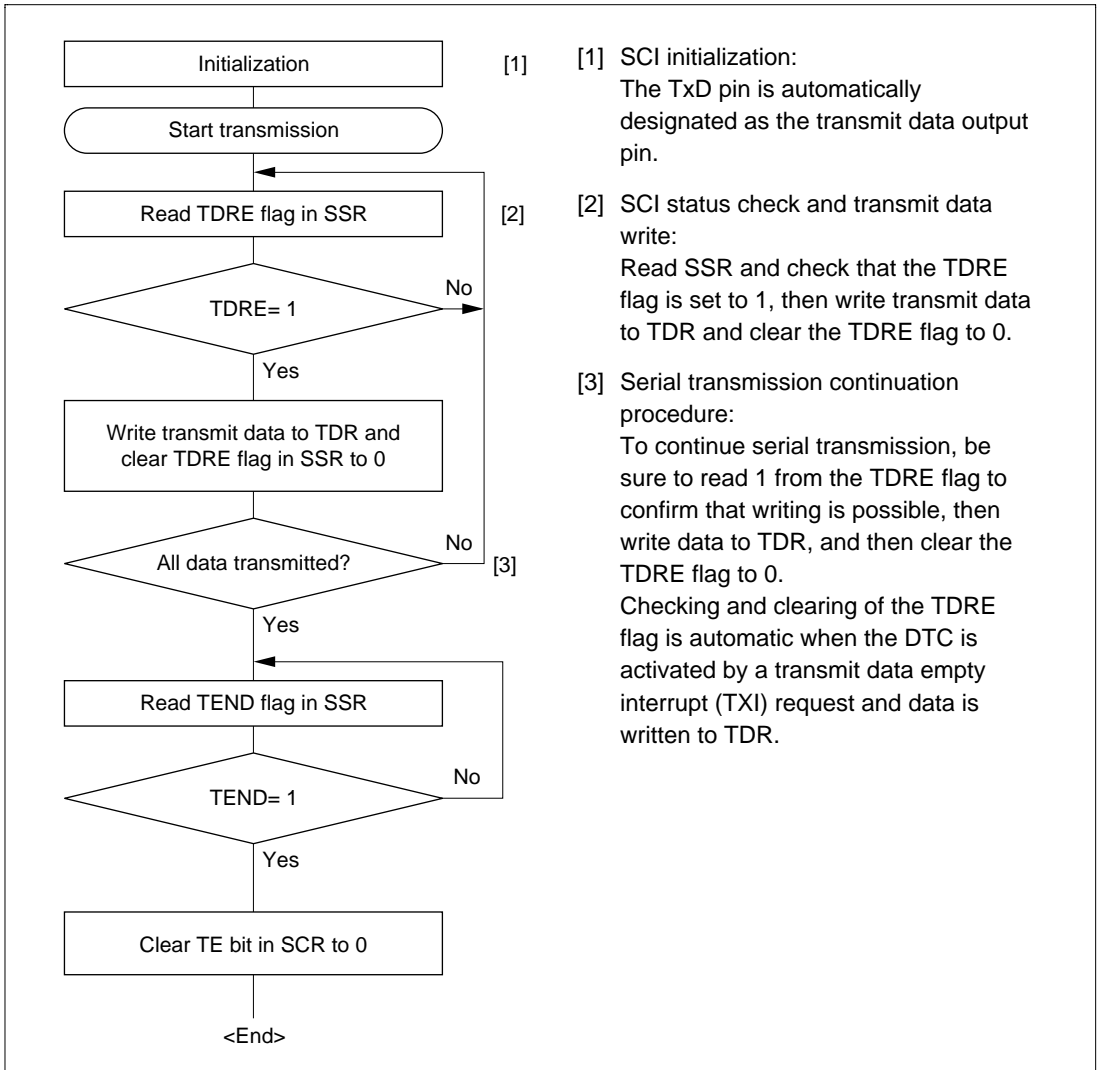

Figure 12-16 Sample Serial Transmission Flowchart

In serial transmission, the SCI operates as described below.

[1] The SCI monitors the TDRE flag in SSR, and if is 0, recognizes that data has been written to TDR, and transfers the data from TDR to TSR.

[2] After transferring data from TDR to TSR, the SCI sets the TDRE flag to 1 and starts transmission. If the TIE bit is set to 1 at this time, a transmit data empty interrupt (TXI) is generated.

When clock output mode has been set, the SCI outputs 8 serial clock pulses. When use of an external clock has been specified, data is output synchronized with the input clock.

The serial transmit data is sent from the TxD pin starting with the LSB (bit 0) and ending with the MSB (bit 7).

[3] The SCI checks the TDRE flag at the timing for sending the MSB (bit 7).

If the TDRE flag is cleared to 0, data is transferred from TDR to TSR, and serial transmission of the next frame is started.

If the TDRE flag is set to 1, the TEND flag in SSR is set to 1, the MSB (bit 7) is sent, and the TxD pin maintains its state.

If the TEIE bit in SCR is set to 1 at this time, a TEI interrupt request is generated.

[4] After completion of serial transmission, the SCK pin is fixed.

Figure 12-17 shows an example of SCI operation in transmission.

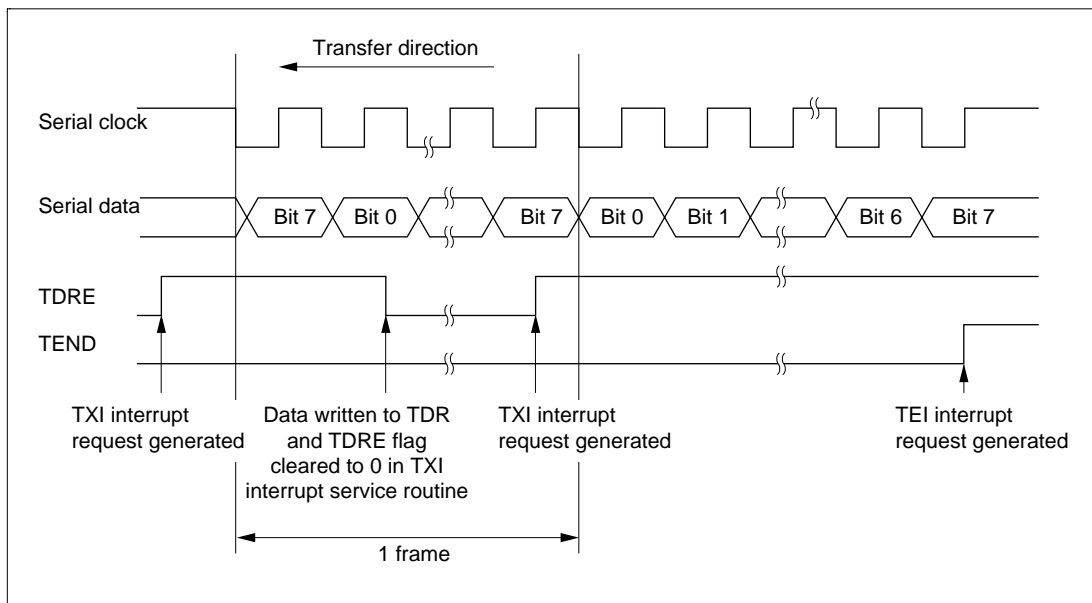

Figure 12-17 Example of SCI Operation in Transmission

- Serial data reception (clocked synchronous mode)

Figure 12-18 shows a sample flowchart for serial reception.

The following procedure should be used for serial data reception.

When changing the operating mode from asynchronous to clocked synchronous, be sure to check that the ORER, PER, and FER flags are all cleared to 0.

The RDRF flag will not be set if the FER or PER flag is set to 1, and neither transmit nor receive operations will be possible.

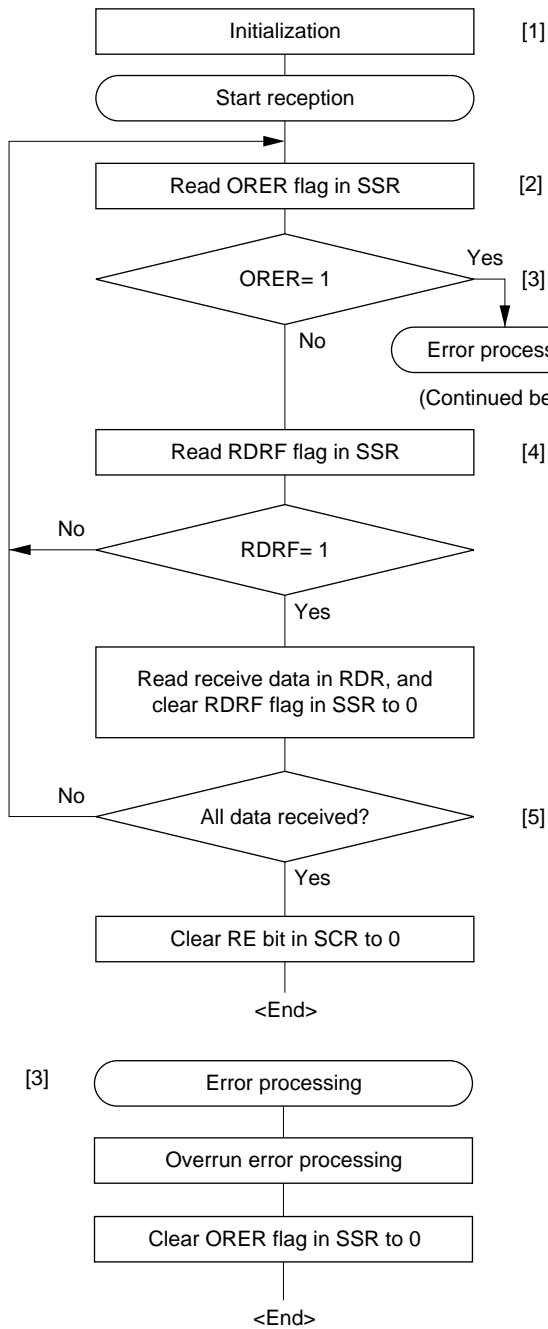

- [1] SCI initialization:
The RxD pin is automatically designated as the receive data input pin.
- [2] [3] Receive error processing:
If a receive error occurs, read the ORER flag in SSR, and after performing the appropriate error processing, clear the ORER flag to 0. Transfer cannot be resumed if the ORER flag is set to 1.
- [4] SCI status check and receive data read:
Read SSR and check that the RDRF flag is set to 1, then read the receive data in RDR and clear the RDRF flag to 0. Transition of the RDRF flag from 0 to 1 can also be identified by an RXI interrupt.
- [5] Serial reception continuation procedure:
To continue serial reception, before the MSB (bit 7) of the current frame is received, finish reading the RDRF flag, reading RDR, and clearing the RDRF flag to 0. The RDRF flag is cleared automatically when the DTC is activated by a receive data full interrupt (RXI) request and the RDR value is read.

Figure 12-18 Sample Serial Reception Flowchart

In serial reception, the SCI operates as described below.

[1] The SCI performs internal initialization in synchronization with serial clock input or output.

[2] The received data is stored in RSR in LSB-to-MSB order.

After reception, the SCI checks whether the RDRF flag is 0 and the receive data can be transferred from RSR to RDR.

If this check is passed, the RDRF flag is set to 1, and the receive data is stored in RDR. If a receive error is detected in the error check, the operation is as shown in table 12-11.

Neither transmit nor receive operations can be performed subsequently when a receive error has been found in the error check.

[3] If the RIE bit in SCR is set to 1 when the RDRF flag changes to 1, a receive data full interrupt (RXI) request is generated.

Also, if the RIE bit in SCR is set to 1 when the ORER flag changes to 1, a receive error interrupt (ERI) request is generated.

Figure 12-19 shows an example of SCI operation in reception.

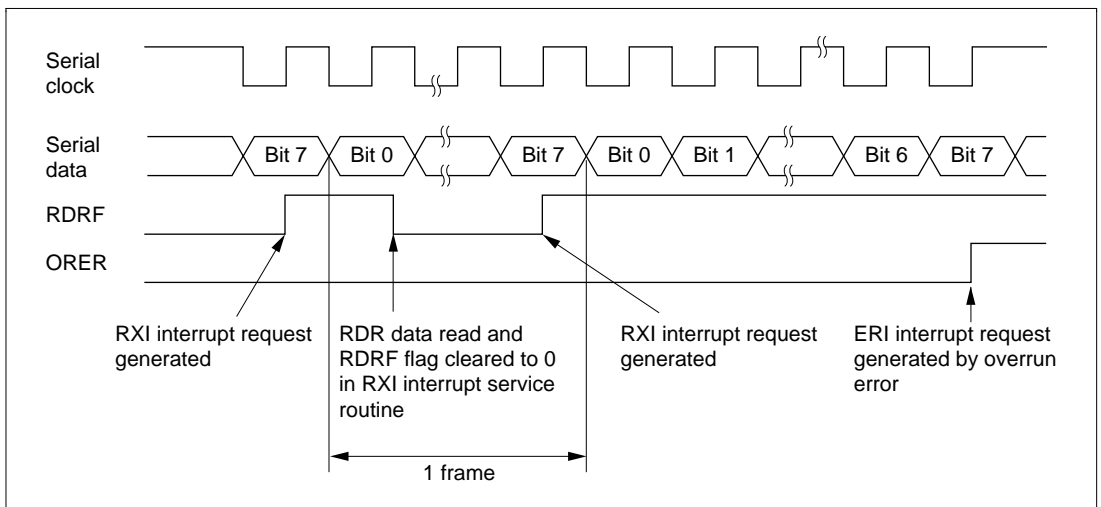
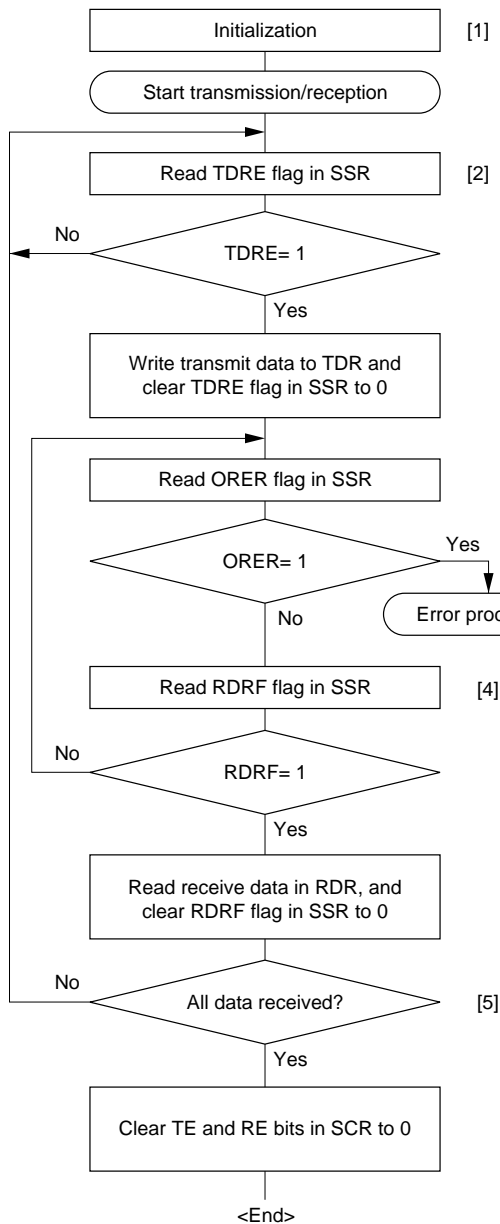

Figure 12-19 Example of SCI Operation in Reception

- Simultaneous serial data transmission and reception (clocked synchronous mode)

Figure 12-20 shows a sample flowchart for simultaneous serial transmit and receive operations.

The following procedure should be used for simultaneous serial data transmit and receive operations.



- [1] SCI initialization:
The TxD pin is designated as the transmit data output pin, and the RxD pin is designated as the receive data input pin, enabling simultaneous transmit and receive operations.
- [2] SCI status check and transmit data write:
Read SSR and check that the TDRE flag is set to 1, then write transmit data to TDR and clear the TDRE flag to 0. Transition of the TDRE flag from 0 to 1 can also be identified by a TXI interrupt.
- [3] Receive error processing:
If a receive error occurs, read the ORER flag in SSR, and after performing the appropriate error processing, clear the ORER flag to 0. Transmission/reception cannot be resumed if the ORER flag is set to 1.
- [4] SCI status check and receive data read:
Read SSR and check that the RDRF flag is set to 1, then read the receive data in RDR and clear the RDRF flag to 0. Transition of the RDRF flag from 0 to 1 can also be identified by an RXI interrupt.
- [5] Serial transmission/reception continuation procedure:
To continue serial transmission/reception, before the MSB (bit 7) of the current frame is received, finish reading the RDRF flag, reading RDR, and clearing the RDRF flag to 0. Also, before the MSB (bit 7) of the current frame is transmitted, read 1 from the TDRE flag to confirm that writing is possible. Then write data to TDR and clear the TDRE flag to 0. Checking and clearing of the TDRE flag is automatic when the DTC is activated by a transmit data empty interrupt (TXI) request and data is written to TDR. Also, the RDRF flag is cleared automatically when the DTC is activated by a receive data full interrupt (RXI) request and the RDR value is read.

Note: When switching from transmit or receive operation to simultaneous transmit and receive operations, first clear the TE bit and RE bit to 0, then set both these bits to 1 simultaneously.

Figure 12-20 Sample Flowchart of Simultaneous Serial Transmit and Receive Operations

12.4 SCI Interrupts

The SCI has four interrupt sources: the transmit-end interrupt (TEI) request, receive-error interrupt (ERI) request, receive-data-full interrupt (RXI) request, and transmit-data-empty interrupt (TXI) request. Table 12-12 shows the interrupt sources and their relative priorities. Individual interrupt sources can be enabled or disabled with the TIE, RIE, and TEIE bits in the SCR. Each kind of interrupt request is sent to the interrupt controller independently.

When the TDRE flag in SSR is set to 1, a TXI interrupt request is generated. When the TEND flag in SSR is set to 1, a TEI interrupt request is generated. A TXI interrupt can activate the DTC to perform data transfer. The TDRE flag is cleared to 0 automatically when data transfer is performed by the DTC. The DTC cannot be activated by a TEI interrupt request.

When the RDRF flag in SSR is set to 1, an RXI interrupt request is generated. When the ORER, PER, or FER flag in SSR is set to 1, an ERI interrupt request is generated. An RXI interrupt can activate the DTC to perform data transfer. The RDRF flag is cleared to 0 automatically when data transfer is performed by the DTC. The DTC cannot be activated by an ERI interrupt request.

12.5 Usage Notes

The following points should be noted when using the SCI.

Relation between Writes to TDR and the TDRE Flag

The TDRE flag in SSR is a status flag that indicates that transmit data has been transferred from TDR to TSR. When the SCI transfers data from TDR to TSR, the TDRE flag is set to 1.

Data can be written to TDR regardless of the state of the TDRE flag. However, if new data is written to TDR when the TDRE flag is cleared to 0, the data stored in TDR will be lost since it has not yet been transferred to TSR. It is therefore essential to check that the TDRE flag is set to 1 before writing transmit data to TDR.

Operation when Multiple Receive Errors Occur Simultaneously

If a number of receive errors occur at the same time, the state of the status flags in SSR is as shown in table 12-13. If there is an overrun error, data is not transferred from RSR to RDR, and the receive data is lost.

Table 12-13 State of SSR Status Flags and Transfer of Receive Data

SSR Status Flags				Receive Data Transfer	
RDRF	ORER	FER	PER	RSR to RDR	Receive Error Status
1	1	0	0	X	Overrun error
0	0	1	0	○	Framing error
0	0	0	1	○	Parity error
1	1	1	0	X	Overrun error + framing error
1	1	0	1	X	Overrun error + parity error
0	0	1	1	○	Framing error + parity error
1	1	1	1	X	Overrun error + framing error + parity error

Notes: ○: Receive data is transferred from RSR to RDR.

X: Receive data is not transferred from RSR to RDR.

Break Detection and Processing (Asynchronous Mode Only): When framing error (FER) detection is performed, a break can be detected by reading the RxD pin value directly. In a break, the input from the RxD pin becomes all 0s, and so the FER flag is set, and the parity error flag (PER) may also be set.

Note that, since the SCI continues the receive operation after receiving a break, even if the FER flag is cleared to 0, it will be set to 1 again.

Sending a Break (Asynchronous Mode Only): The TxD pin has a dual function as an I/O port whose direction (input or output) is determined by DR and DDR. This can be used to send a break.

Between serial transmission initialization and setting of the TE bit to 1, the mark state is replaced by the value of DR (the pin does not function as the TxD pin until the TE bit is set to 1). Consequently, DDR and DR for the port corresponding to the TxD pin are first set to 1.

To send a break during serial transmission, first clear DR to 0, then clear the TE bit to 0.

When the TE bit is cleared to 0, the transmitter is initialized regardless of the current transmission state, the TxD pin becomes an I/O port, and 0 is output from the TxD pin.

Receive Error Flags and Transmit Operations (Clocked Synchronous Mode Only):

Transmission cannot be started when a receive error flag (ORER, PER, or FER) is set to 1, even if the TDRE flag is cleared to 0. Be sure to clear the receive error flags to 0 before starting transmission.

Note also that receive error flags cannot be cleared to 0 even if the RE bit is cleared to 0.

Receive Data Sampling Timing and Reception Margin in Asynchronous Mode:

In asynchronous mode, the SCI operates on a basic clock with a frequency of 16 times the transfer rate.

In reception, the SCI samples the falling edge of the start bit using the basic clock, and performs internal synchronization. Receive data is latched internally at the rising edge of the 8th pulse of the basic clock. This is illustrated in figure 12-21.

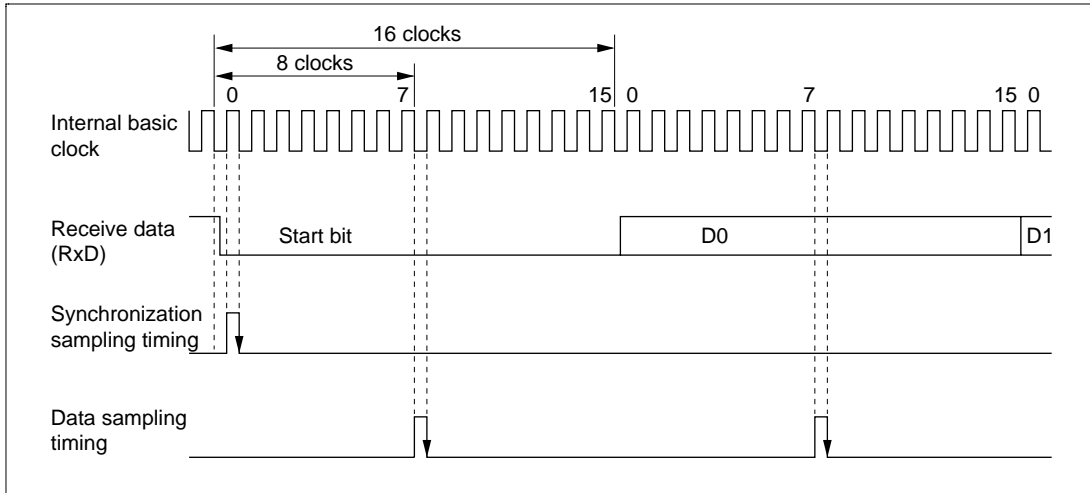

Figure 12-21 Receive Data Sampling Timing in Asynchronous Mode

Thus the reception margin in asynchronous mode is given by formula (1) below.

$$M = \left| \left(0.5 - \frac{1}{2N} \right) - (L - 0.5)F - \frac{|D - 0.5|}{N} (1 + F) \right| \times 100\%$$

... Formula (1)

Where

- M : Reception margin (%)
- N : Ratio of bit rate to clock (N = 16)
- D : Clock duty (D = 0 to 1.0)
- L : Frame length (L = 9 to 12)
- F : Absolute value of clock rate deviation

Assuming values of F = 0 and D = 0.5 in formula (1), a reception margin of 46.875% is given by formula (2) below.

When D = 0.5 and F = 0,

$$M = \left(0.5 - \frac{1}{2 \times 16} \right) \times 100\%$$

$$= 46.875\%$$

... Formula (2)

However, this is only the computed value, and a margin of 20% to 30% should be allowed in system design.

Restrictions on Use of DTC

- When an external clock source is used as the serial clock, the transmit clock should not be input until at least 5 ϕ clock cycles after TDR is updated by the DTC. Misoperation may occur if the transmit clock is input within 4 ϕ clocks after TDR is updated. (Figure 12-22)
- When RDR is read by the DTC, be sure to set the activation source to the relevant SCI reception end interrupt (RXI).

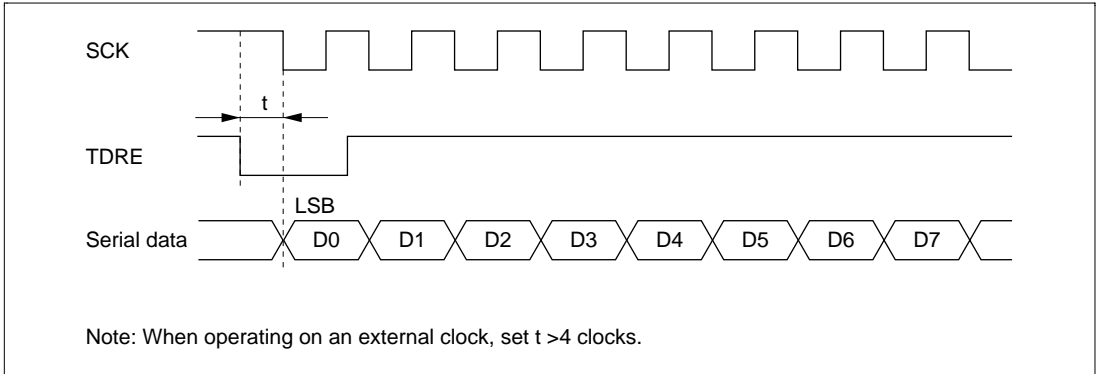

Figure 12-22 Example of Clocked Synchronous Transmission by DTC

Section 13 Smart Card Interface

13.1 Overview

SCI supports an IC card (Smart Card) interface conforming to ISO/IEC 7816-3 (Identification Card) as a serial communication interface extension function.

Switching between the normal serial communication interface and the Smart Card interface is carried out by means of a register setting.

13.1.1 Features

Features of the Smart Card interface supported by the H8S/2355 are as follows.

- Asynchronous mode
 - Data length: 8 bits
 - Parity bit generation and checking
 - Transmission of error signal (parity error) in receive mode
 - Error signal detection and automatic data retransmission in transmit mode
 - Direct convention and inverse convention both supported
- On-chip baud rate generator allows any bit rate to be selected
- Three interrupt sources
 - Three interrupt sources (transmit data empty, receive data full, and transmit/receive error) that can issue requests independently
 - The transmit data empty interrupt and receive data full interrupt can activate the data transfer controller (DTC) to execute data transfer

13.1.2 Block Diagram

Figure 13-1 shows a block diagram of the Smart Card interface.

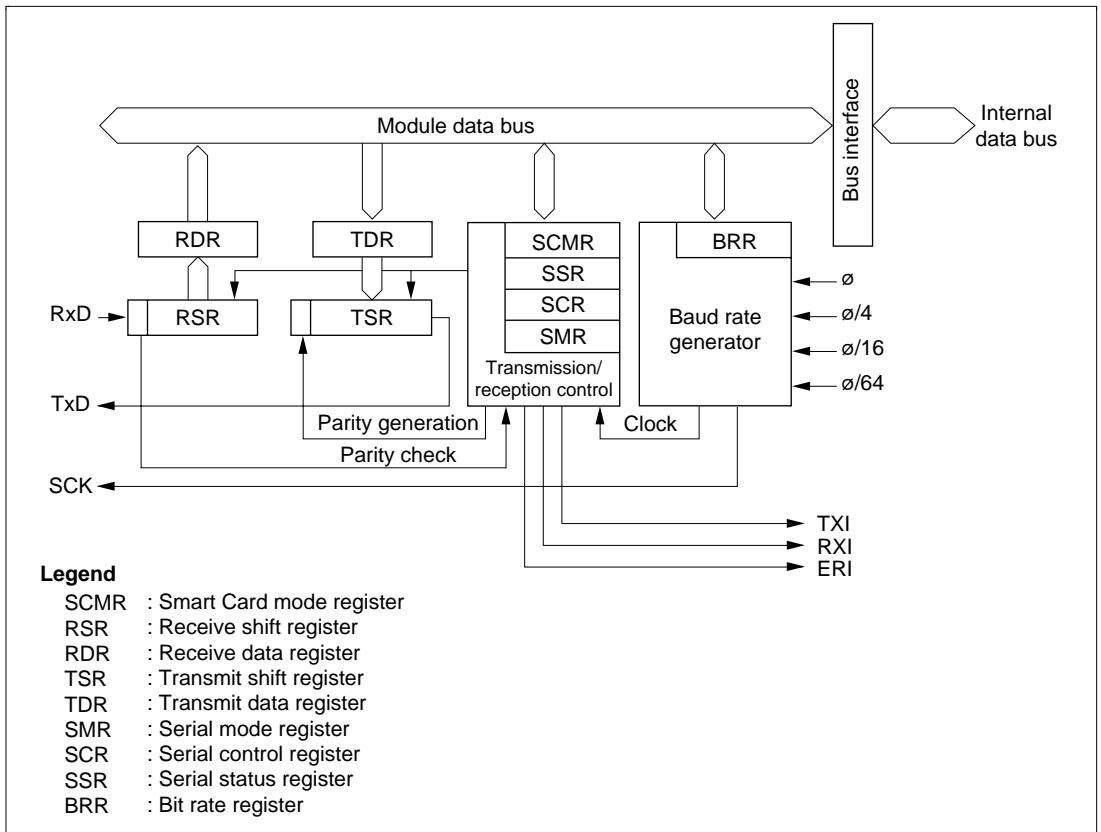

Figure 13-1 Block Diagram of Smart Card Interface

13.1.3 Pin Configuration

Table 13-1 shows the Smart Card interface pin configuration.

Table 13-1 Smart Card Interface Pins

Channel	Pin Name	Symbol	I/O	Function
0	Serial clock pin 0	SCK0	I/O	SCI0 clock input/output
	Receive data pin 0	RxD0	Input	SCI0 receive data input
	Transmit data pin 0	TxD0	Output	SCI0 transmit data output
1	Serial clock pin 1	SCK1	I/O	SCI1 clock input/output
	Receive data pin 1	RxD1	Input	SCI1 receive data input
	Transmit data pin 1	TxD1	Output	SCI1 transmit data output
2	Serial clock pin 2	SCK2	I/O	SCI2 clock input/output
	Receive data pin 2	RxD2	Input	SCI2 receive data input
	Transmit data pin 2	TxD2	Output	SCI2 transmit data output

13.1.4 Register Configuration

Table 13-2 shows the registers used by the Smart Card interface. Details of SMR, BRR, SCR, TDR, RDR, and MSTPCR are the same as for the normal SCI function: see the register descriptions in section 12, Serial Communication Interface.

Table 13-2 Smart Card Interface Registers

Channel	Name	Abbreviation	R/W	Initial Value	Address* ¹
0	Serial mode register 0	SMR0	R/W	H'00	H'FF78
	Bit rate register 0	BRR0	R/W	H'FF	H'FF79
	Serial control register 0	SCR0	R/W	H'00	H'FF7A
	Transmit data register 0	TDR0	R/W	H'FF	H'FF7B
	Serial status register 0	SSR0	R/(W)* ²	H'84	H'FF7C
	Receive data register 0	RDR0	R	H'00	H'FF7D
	Smart card mode register 0	SCMR0	R/W	H'F2	H'FF7E
1	Serial mode register 1	SMR1	R/W	H'00	H'FF80
	Bit rate register 1	BRR1	R/W	H'FF	H'FF81
	Serial control register 1	SCR1	R/W	H'00	H'FF82
	Transmit data register 1	TDR1	R/W	H'FF	H'FF83
	Serial status register 1	SSR1	R/(W)* ²	H'84	H'FF84
	Receive data register 1	RDR1	R	H'00	H'FF85
	Smart card mode register 1	SCMR1	R/W	H'F2	H'FF86
2	Serial mode register 2	SMR2	R/W	H'00	H'FF88
	Bit rate register 2	BRR2	R/W	H'FF	H'FF89
	Serial control register 2	SCR2	R/W	H'00	H'FF8A
	Transmit data register 2	TDR2	R/W	H'FF	H'FF8B
	Serial status register 2	SSR2	R/(W)* ²	H'84	H'FF8C
	Receive data register 2	RDR2	R	H'00	H'FF8D
	Smart card mode register 2	SCMR2	R/W	H'F2	H'FF8E
All	Module stop control register	MSTPCR	R/W	H'3FFF	H'FF3C

- Notes: 1. Lower 16 bits of the address.
 2. Can only be written with 0 for flag clearing.

13.2 Register Descriptions

Registers added with the Smart Card interface and bits for which the function changes are described here.

13.2.1 Smart Card Mode Register (SCMR)

Bit	:	7	6	5	4	3	2	1	0
		—	—	—	—	SDIR	SINV	—	SMIF
Initial value :		1	1	1	1	0	0	1	0
R/W	:	—	—	—	—	R/W	R/W	—	R/W

SCMR is an 8-bit readable/writable register that selects the Smart Card interface function.

SCMR is initialized to HF2 by a reset, and in standby mode or module stop mode.

Bits 7 to 4—Reserved: Read-only bits, always read as 1.

Bit 3—Smart Card Data Transfer Direction (SDIR): Selects the serial/parallel conversion format.

Bit 3

SDIR	Description
0	TDR contents are transmitted LSB-first Receive data is stored in RDR LSB-first (Initial value)
1	TDR contents are transmitted MSB-first Receive data is stored in RDR MSB-first

Bit 2—Smart Card Data Invert (SINV): Specifies inversion of the data logic level. This function is used together with the SDIR bit for communication with an inverse convention card. The SINV bit does not affect the logic level of the parity bit. For parity-related setting procedures, see section 13.3.4, Register Settings.

Bit 2

SINV	Description
0	TDR contents are transmitted as they are Receive data is stored as it is in RDR (Initial value)
1	TDR contents are inverted before being transmitted Receive data is stored in inverted form in RDR

Bit 1—Reserved: Read-only bit, always read as 1.

Bit 0—Smart Card Interface Mode Select (SMIF): Enables or disables the Smart Card interface function.

Bit 0 SMIF	Description
0	Smart Card interface function is disabled (Initial value)
1	Smart Card interface function is enabled

13.2.2 Serial Status Register (SSR)

Bit	7	6	5	4	3	2	1	0
	TDRE	RDRF	ORER	ERS	PER	TEND	MPB	MPBT
Initial value :	1	0	0	0	0	1	0	0
R/W :	R/(W)*	R/(W)*	R/(W)*	R/(W)*	R/(W)*	R	R	R/W

Note: * Only 0 can be written to bits 7 to 3, to clear these flags.

Bit 4 of SSR has a different function in Smart Card interface mode. Coupled with this, the setting conditions for bit 2, TEND, are also different.

Bits 7 to 5—Operate in the same way as for the normal SCI. For details, see section 12.2.7, Serial Status Register (SSR).

Bit 4—Error Signal Status (ERS): In Smart Card interface mode, bit 4 indicates the status of the error signal sent back from the receiving end in transmission. Framing errors are not detected in Smart Card interface mode.

Bit 4 ERS	Description
0	[Clearing condition] (Initial value) <ul style="list-style-type: none"> Upon reset, and in standby mode or module stop mode When 0 is written to ERS after reading ERS = 1
1	[Setting condition] <p>When the low level of the error signal is sampled</p>

Note: Clearing the TE bit in SCR to 0 does not affect the ERS flag, which retains its previous state.

Bits 3 to 0—Operate in the same way as for the normal SCI. For details, see section 12.2.7, Serial Status Register (SSR).

However, the setting conditions for the TEND bit, are as shown below.

Bit 2

TEND	Description
0	[Clearing conditions] (Initial value) <ul style="list-style-type: none"> • When 0 is written to TDRE after reading TDRE = 1 • When the DTC is activated by a TXI interrupt and write data to TDR
1	[Setting conditions] <ul style="list-style-type: none"> • Upon reset, and in standby mode or module stop mode • When the TE bit in SCR is 0 and the ERS bit is also 0 • When TDRE = 1 and ERS = 0 (normal transmission) 2.5 etu after transmission of a 1-byte serial character when GM = 0 • When TDRE = 1 and ERS = 0 (normal transmission) 1.0 etu after transmission of a 1-byte serial character when GM = 1

Note: etu: Elementary Time Unit (time for transfer of 1 bit)

13.2.3 Serial Mode Register (SMR)

Bit	7	6	5	4	3	2	1	0
	GM	CHR	PE	O/ \bar{E}	STOP	MP	CKS1	CKS0
Initial value :	0	0	0	0	0	0	0	0
Set value* :	GM	0	1	O/ \bar{E}	1	0	CKS1	CKS0
R/W :	R/W	R/W	R/W	R/W	R/W	R/W	R/W	R/W

Note: *When the smart card interface is used, be sure to make the 0 or 1 setting shown for bits 6, 5, 3, and 2.

The function of bit 7 of SMR changes in smart card interface mode.

Bit 7—GSM Mode (GM): Sets the smart card interface function to GSM mode.

This bit is cleared to 0 when the normal smart card interface is used. In GSM mode, this bit is set to 1, the timing of setting of the TEND flag that indicates transmission completion is advanced and clock output control mode addition is performed. The contents of the clock output control mode addition are specified by bits 1 and 0 of the serial control register (SCR).

Bit 7 GM	Description	
0	Normal smart card interface mode operation	(Initial value)
	<ul style="list-style-type: none"> TEND flag generation 12.5 etu after beginning of start bit Clock output ON/OFF control only 	
1	GSM mode smart card interface mode operation	
	<ul style="list-style-type: none"> TEND flag generation 11.0 etu after beginning of start bit High/low fixing control possible in addition to clock output ON/OFF control (set by SCR) 	

Note: etu: Elementary time unit (time for transfer of 1 bit)

Bits 6 to 0—Operate in the same way as for the normal SCI.

For details, see section 12.2.5, Serial Mode Register (SMR).

13.2.4 Serial Control Register (SCR)

Bit	7	6	5	4	3	2	1	0
	TIE	RIE	TE	RE	MPIE	TEIE	CKE1	CKE0
Initial value :	0	0	0	0	0	0	0	0
R/W :	R/W	R/W	R/W	R/W	R/W	R/W	R/W	R/W

In smart card interface mode, the function of bits 1 and 0 of SCR changes when bit 7 of the serial mode register (SMR) is set to 1.

Bits 7 to 2—Operate in the same way as for the normal SCI.

For details, see section 12.2.6, Serial Control Register (SCR).

Bits 1 and 0—Clock Enable 1 and 0 (CKE1, CKE0): These bits are used to select the SCI clock source and enable or disable clock output from the SCK pin.

In smart card interface mode, in addition to the normal switching between clock output enabling and disabling, the clock output can be specified as to be fixed high or low.

SCMR	SMR	SCR Setting		SCK Pin Function
SMIF	C/A, GM	CKE1	CKE0	
0	See the SCI			
1	0	0	0	Operates as port I/O pin
1	0	0	1	Outputs clock as SCK output pin
1	1	0	0	Operates as SCK output pin, with output fixed low
1	1	0	1	Outputs clock as SCK output pin
1	1	1	0	Operates as SCK output pin, with output fixed high
1	1	1	1	Outputs clock as SCK output pin

13.3 Operation

13.3.1 Overview

The main functions of the Smart Card interface are as follows.

- One frame consists of 8-bit data plus a parity bit.
- In transmission, a guard time of at least 2 etu (Elementary Time Unit: the time for transfer of one bit) is left between the end of the parity bit and the start of the next frame.
- If a parity error is detected during reception, a low error signal level is output for one etu period, 10.5 etu after the start bit.
- If the error signal is sampled during transmission, the same data is transmitted automatically after the elapse of 2 etu or longer.
- Only asynchronous communication is supported; there is no clocked synchronous communication function.

13.3.2 Pin Connections

Figure 13-2 shows a schematic diagram of Smart Card interface related pin connections.

In communication with an IC card, since both transmission and reception are carried out on a single data transmission line, the TxD pin and RxD pin should be connected with the LSI pin. The data transmission line should be pulled up to the V_{CC} power supply with a resistor.

When the clock generated on the Smart Card interface is used by an IC card, the SCK pin output is input to the CLK pin of the IC card. No connection is needed if the IC card uses an internal clock.

LSI port output is used as the reset signal.

Other pins must normally be connected to the power supply or ground.

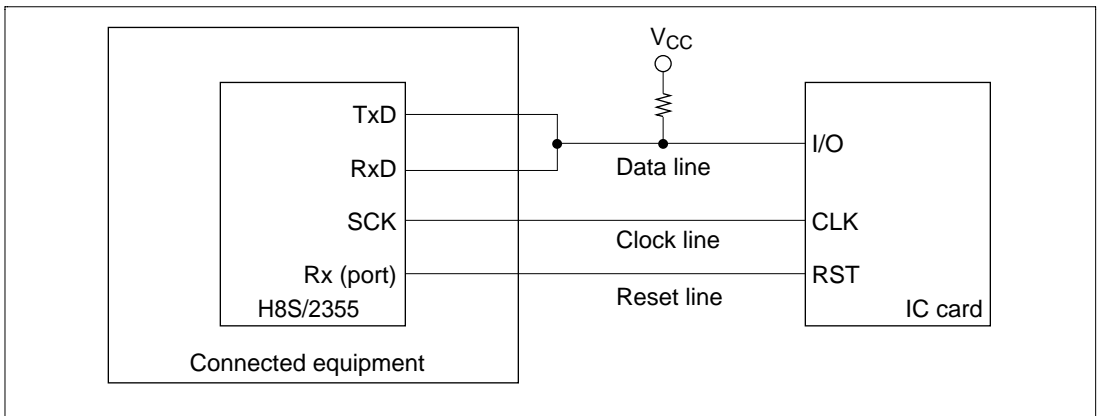

Figure 13-2 Schematic Diagram of Smart Card Interface Pin Connections

Note: If an IC card is not connected, and the TE and RE bits are both set to 1, closed transmission/reception is possible, enabling self-diagnosis to be carried out.

13.3.3 Data Format

Figure 13-3 shows the Smart Card interface data format. In reception in this mode, a parity check is carried out on each frame, and if an error is detected an error signal is sent back to the transmitting end, and retransmission of the data is requested. If an error signal is sampled during transmission, the same data is retransmitted.

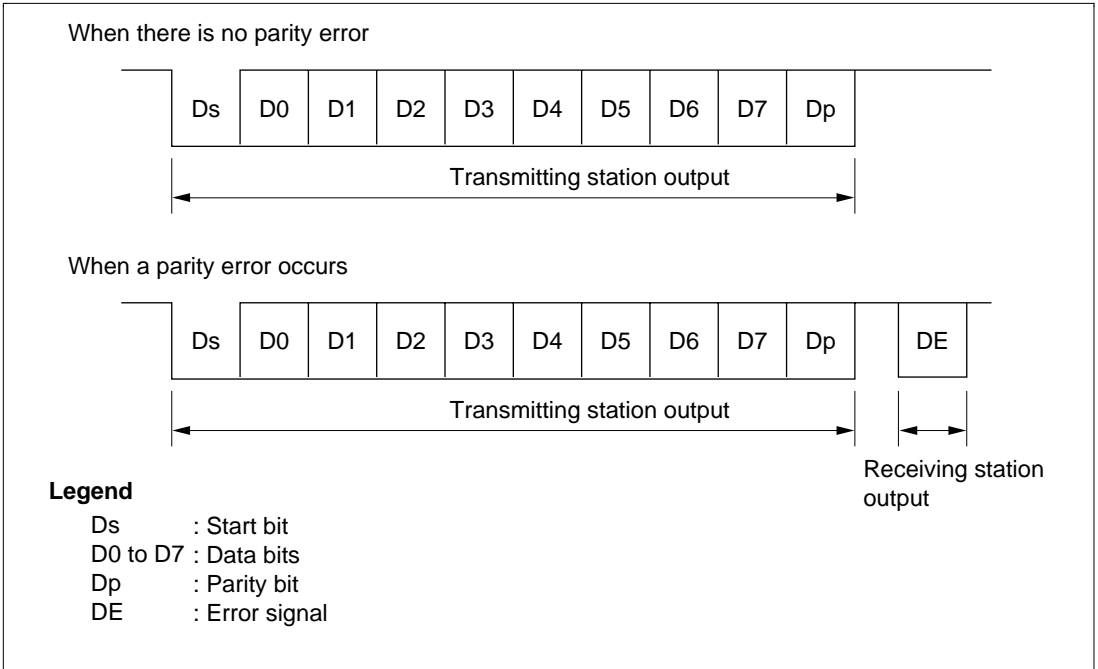

Figure 13-3 Smart Card Interface Data Format

The operation sequence is as follows.

- [1] When the data line is not in use it is in the high-impedance state, and is fixed high with a pull-up resistor.
- [2] The transmitting station starts transfer of one frame of data. The data frame starts with a start bit (Ds, low-level), followed by 8 data bits (D0 to D7) and a parity bit (Dp).
- [3] With the Smart Card interface, the data line then returns to the high-impedance state. The data line is pulled high with a pull-up resistor.
- [4] The receiving station carries out a parity check.
 - If there is no parity error and the data is received normally, the receiving station waits for reception of the next data.
 - If a parity error occurs, however, the receiving station outputs an error signal (DE, low-level) to request retransmission of the data. After outputting the error signal for the prescribed length of time, the receiving station places the signal line in the high-impedance state again. The signal line is pulled high again by a pull-up resistor.
- [5] If the transmitting station does not receive an error signal, it proceeds to transmit the next data frame.
 - If it does receive an error signal, however, it returns to step [2] and retransmits the erroneous data.

13.3.4 Register Settings

Table 13-3 shows a bit map of the registers used by the smart card interface.

Bits indicated as 0 or 1 must be set to the value shown. The setting of other bits is described below.

Table 13-3 Smart Card Interface Register Settings

Register	Bit							
	Bit 7	Bit 6	Bit 5	Bit 4	Bit 3	Bit 2	Bit 1	Bit 0
SMR	GM	0	1	O/ \bar{E}	1	0	CKS1	CKS0
BRR	BRR7	BRR6	BRR5	BRR4	BRR3	BRR2	BRR1	BRR0
SCR	TIE	RIE	TE	RE	0	0	CKE1*	CKE0
TDR	TDR7	TDR6	TDR5	TDR4	TDR3	TDR2	TDR1	TDR0
SSR	TDRE	RDRF	ORER	ERS	PER	TEND	0	0
RDR	RDR7	RDR6	RDR5	RDR4	RDR3	RDR2	RDR1	RDR0
SCMR	—	—	—	—	SDIR	SINV	—	SMIF

Notes: — : Unused bit.

*: The CKE1 bit must be cleared to 0 when the GM bit in SMR is cleared to 0.

SMR Setting: The GM bit is cleared to 0 in normal smart card interface mode, and set to 1 in GSM mode. The O/ \bar{E} bit is cleared to 0 if the IC card is of the direct convention type, and set to 1 if of the inverse convention type.

Bits CKS1 and CKS0 select the clock source of the on-chip baud rate generator. See section 13.3.5, Clock.

BRR Setting: BRR is used to set the bit rate. See section 13.3.5, Clock, for the method of calculating the value to be set.

SCR Setting: The function of the TIE, RIE, TE, and RE bits is the same as for the normal SCI. For details, see section 12, Serial Communication Interface.

Bits CKE1 and CKE0 specify the clock output. When the GM bit in SMR is cleared to 0, set these bits to B'00 if a clock is not to be output, or to B'01 if a clock is to be output. When the GM bit in SMR is set to 1, clock output is performed. The clock output can also be fixed high or low.

Smart Card Mode Register (SCMR) Setting:

The SDIR bit is cleared to 0 if the IC card is of the direct convention type, and set to 1 if of the inverse convention type.

The SINV bit is cleared to 0 if the IC card is of the direct convention type, and set to 1 if of the inverse convention type.

The SMIF bit is set to 1 in the case of the Smart Card interface.

Examples of register settings and the waveform of the start character are shown below for the two types of IC card (direct convention and inverse convention).

- Direct convention ($SDIR = SINV = \overline{O/\bar{E}} = 0$)

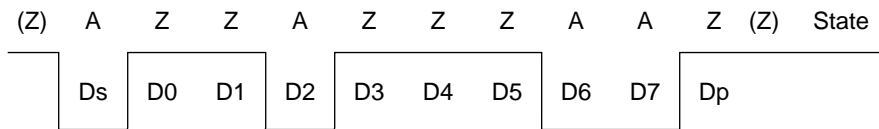

With the direct convention type, the logic 1 level corresponds to state Z and the logic 0 level to state A, and transfer is performed in LSB-first order. The start character data above is H'3B.

The parity bit is 1 since even parity is stipulated for the Smart Card.

- Inverse convention ($SDIR = SINV = \overline{O/\bar{E}} = 1$)

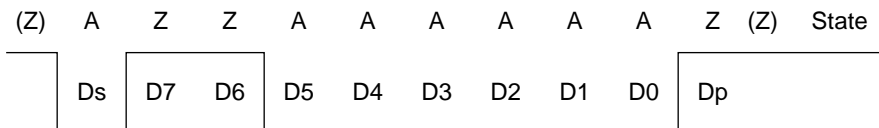

With the inverse convention type, the logic 1 level corresponds to state A and the logic 0 level to state Z, and transfer is performed in MSB-first order. The start character data above is H'3F.

The parity bit is 0, corresponding to state Z, since even parity is stipulated for the Smart Card.

With the H8S/2355, inversion specified by the SINV bit applies only to the data bits, D7 to D0. For parity bit inversion, the $\overline{O/\bar{E}}$ bit in SMR is set to odd parity mode (the same applies to both transmission and reception).

13.3.5 Clock

Only an internal clock generated by the on-chip baud rate generator can be used as the transmit/receive clock for the smart card interface. The bit rate is set with BRR and the CKS1 and CKS0 bits in SMR. The formula for calculating the bit rate is as shown below. Table 13-5 shows some sample bit rates.

If clock output is selected by setting CKE0 to 1, a clock with a frequency of 372 times the bit rate is output from the SCK pin.

$$B = \frac{\phi}{1488 \times 2^{2n-1} \times (N + 1)} \times 10^6$$

Where: N = Value set in BRR (0 ≤ N ≤ 255)

B = Bit rate (bit/s)

ϕ = Operating frequency (MHz)

n = See table 13-4

Table 13-4 Correspondence between n and CKS1, CKS0

n	CKS1	CKS0
0	0	0
1		1
2	1	0
3		1

Table 13-5 Examples of Bit Rate B (bit/s) for Various BRR Settings (When n = 0)

N	ϕ (MHz)						
	10.00	10.714	13.00	14.285	16.00	18.00	20.00
0	13441	14400	17473	19200	21505	24194	26882
1	6720	7200	8737	9600	10753	12097	13441
2	4480	4800	5824	6400	7168	8065	8961

Note: Bit rates are rounded to the nearest whole number.

The method of calculating the value to be set in the bit rate register (BRR) from the operating frequency and bit rate, on the other hand, is shown below. N is an integer, $0 \leq N \leq 255$, and the smaller error is specified.

$$N = \frac{\phi}{1488 \times 2^{2n-1} \times B} \times 10^6 - 1$$

Table 13-6 Examples of BRR Settings for Bit Rate B (bit/s) (When n = 0)

bit/s	ϕ (MHz)															
	7.1424		10.00		10.7136		13.00		14.2848		16.00		18.00		20.00	
	N	Error	N	Error	N	Error	N	Error	N	Error	N	Error	N	Error	N	Error
9600	0	0.00	1	30	1	25	1	8.99	1	0.00	1	12.01	2	15.99	2	6.60

Table 13-7 Maximum Bit Rate at Various Frequencies (Smart Card Interface Mode)

ϕ (MHz)	Maximum Bit Rate (bit/s)	N	n
7.1424	9600	0	0
10.00	13441	0	0
10.7136	14400	0	0
13.00	17473	0	0
14.2848	19200	0	0
16.00	21505	0	0
18.00	24194	0	0
20.00	26882	0	0

The bit rate error is given by the following formula:

$$\text{Error (\%)} = \left(\frac{\phi}{1488 \times 2^{2n-1} \times B \times (N + 1)} \times 10^6 - 1 \right) \times 100$$

13.3.6 Data Transfer Operations

Initialization: Before transmitting and receiving data, initialize the SCI as described below. Initialization is also necessary when switching from transmit mode to receive mode, or vice versa.

- [1] Clear the TE and RE bits in SCR to 0.
- [2] Clear the error flags ERS, PER, and ORER in SSR to 0.
- [3] Set the $\overline{O/E}$ bit and CKS1 and CKS0 bits in SMR. Clear the $\overline{C/A}$, CHR, and MP bits to 0, and set the STOP and PE bits to 1.
- [4] Set the SMIF, SDIR, and SINV bits in SCMR.
When the SMIF bit is set to 1, the TxD and RxD pins are both switched from ports to SCI pins, and are placed in the high-impedance state.
- [5] Set the value corresponding to the bit rate in BRR.
- [6] Set the CKE0 bit in SCR. Clear the TIE, RIE, TE, RE, MPIE, TEIE and CKE1 bits to 0.
If the CKE0 bit is set to 1, the clock is output from the SCK pin.
- [7] Wait at least one bit interval, then set the TIE, RIE, TE, and RE bits in SCR. Do not set the TE bit and RE bit at the same time, except for self-diagnosis.

Serial Data Transmission: As data transmission in smart card mode involves error signal sampling and retransmission processing, the processing procedure is different from that for the normal SCI. Figure 13-4 shows a flowchart for transmitting, and figure 13-5 shows the relation between a transmit operation and the internal registers.

- [1] Perform Smart Card interface mode initialization as described above in Initialization.
- [2] Check that the ERS error flag in SSR is cleared to 0.
- [3] Repeat steps [2] and [3] until it can be confirmed that the TEND flag in SSR is set to 1.
- [4] Write the transmit data to TDR, clear the TDRE flag to 0, and perform the transmit operation. The TEND flag is cleared to 0.
- [5] When transmitting data continuously, go back to step [2].
- [6] To end transmission, clear the TE bit to 0.

With the above processing, interrupt servicing or data transfer by the DTC is possible.

If transmission ends and the TEND flag is set to 1 while the TIE bit is set to 1 and interrupt requests are enabled, a transmit data empty interrupt (TXI) request will be generated. If an error occurs in transmission and the ERS flag is set to 1 while the RIE bit is set to 1 and interrupt requests are enabled, a transfer error interrupt (ERI) request will be generated.

The timing for setting the TEND flag depends on the value of the GM bit in SMR. The TEND flag set timing is shown in figure 13-6.

If the DTC is activated by a TXI request, the number of bytes set in the DTC can be transmitted automatically, including automatic retransmission.

For details, see Interrupt Operations and Data Transfer Operation by DTC below.

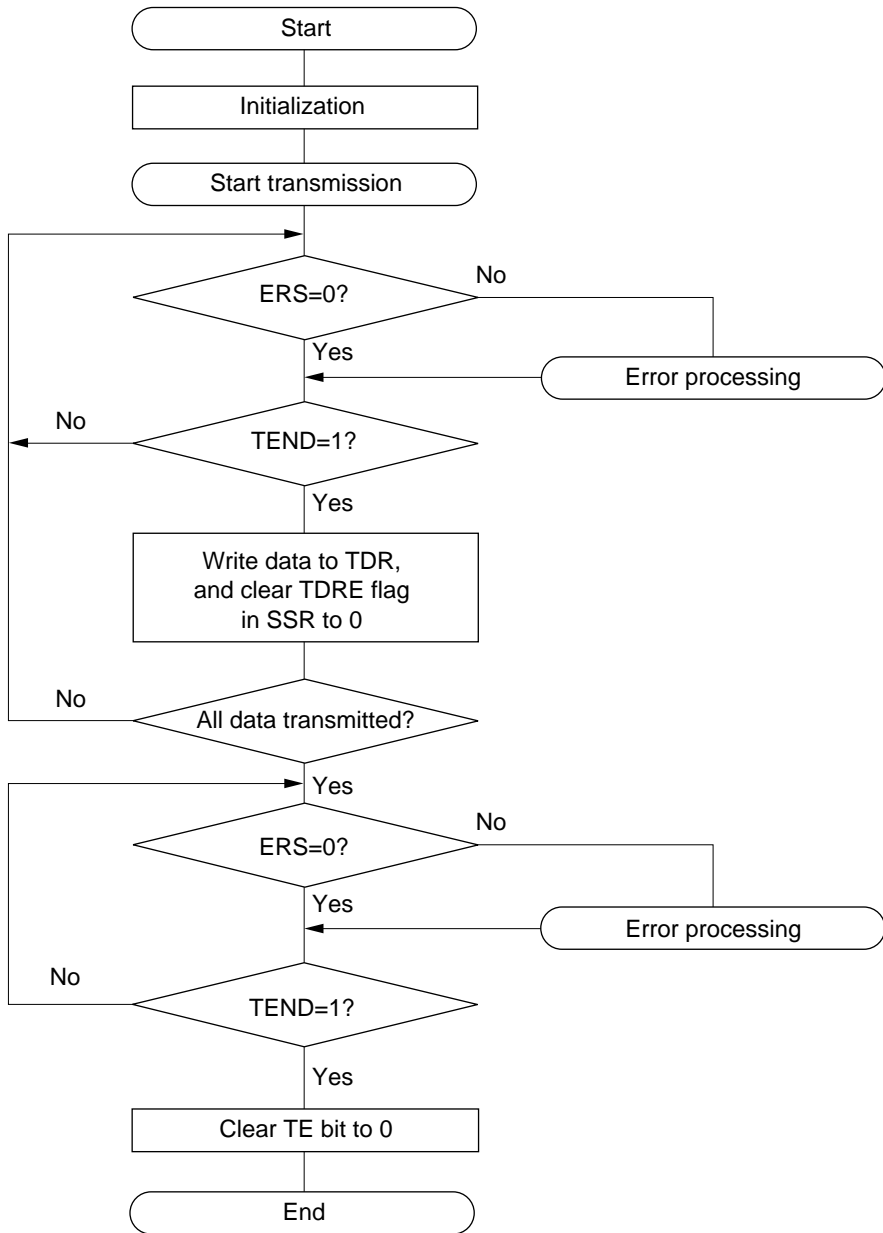

Figure 13-4 Example of Transmission Processing Flow

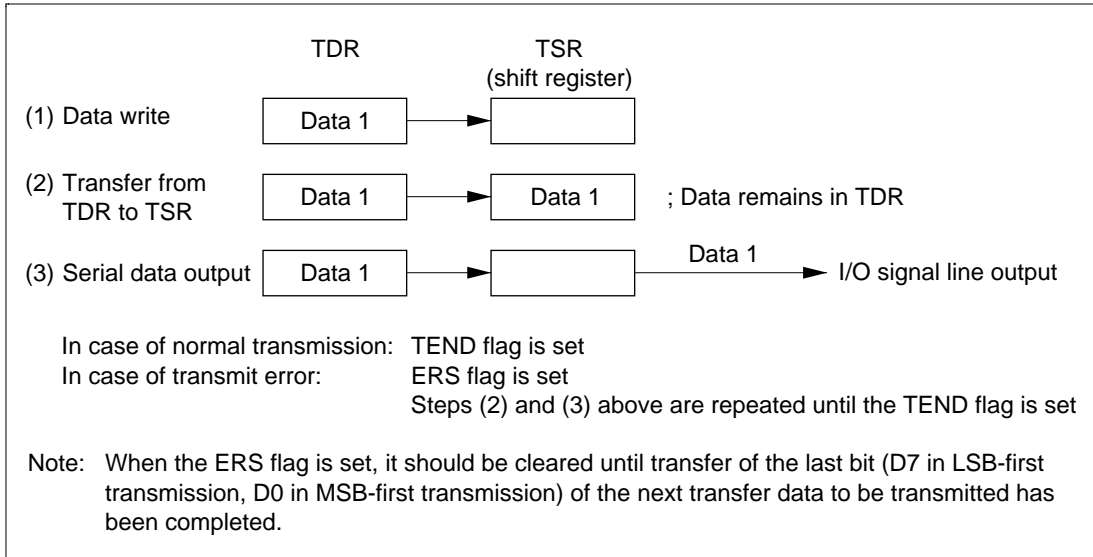

Figure 13-5 Relation Between Transmit Operation and Internal Registers

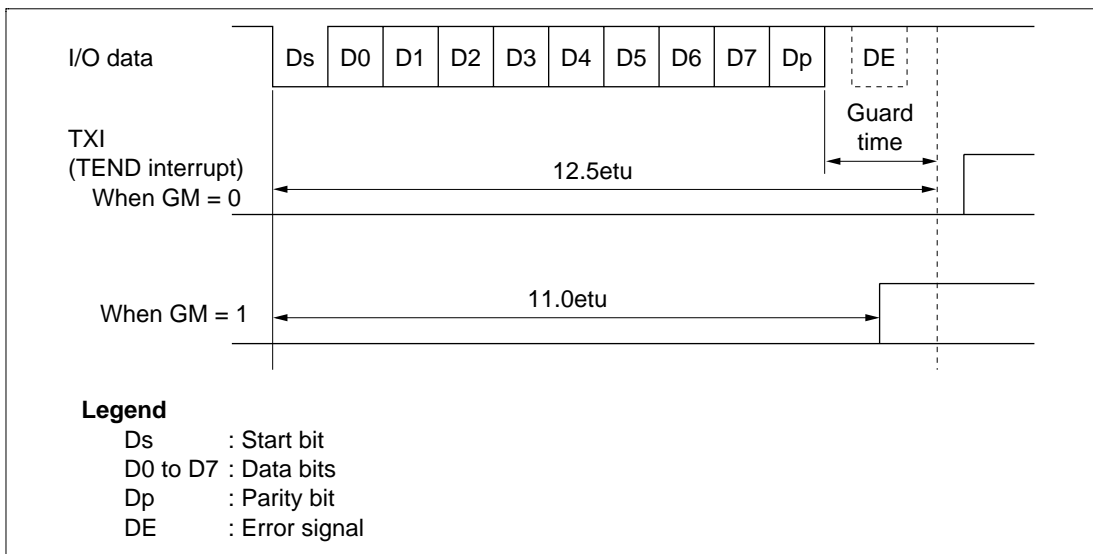

Figure 13-6 TEND Flag Generation Timing in Transmission Operation

Serial Data Reception: Data reception in Smart Card mode uses the same processing procedure as for the normal SCI. Figure 13-7 shows an example of the transmission processing flow.

- [1] Perform Smart Card interface mode initialization as described above in Initialization.
- [2] Check that the ORER flag and PER flag in SSR are cleared to 0. If either is set, perform the appropriate receive error processing, then clear both the ORER and the PER flag to 0.
- [3] Repeat steps [2] and [3] until it can be confirmed that the RDRF flag is set to 1.
- [4] Read the receive data from RDR.
- [5] When receiving data continuously, clear the RDRF flag to 0 and go back to step [2].
- [6] To end reception, clear the RE bit to 0.

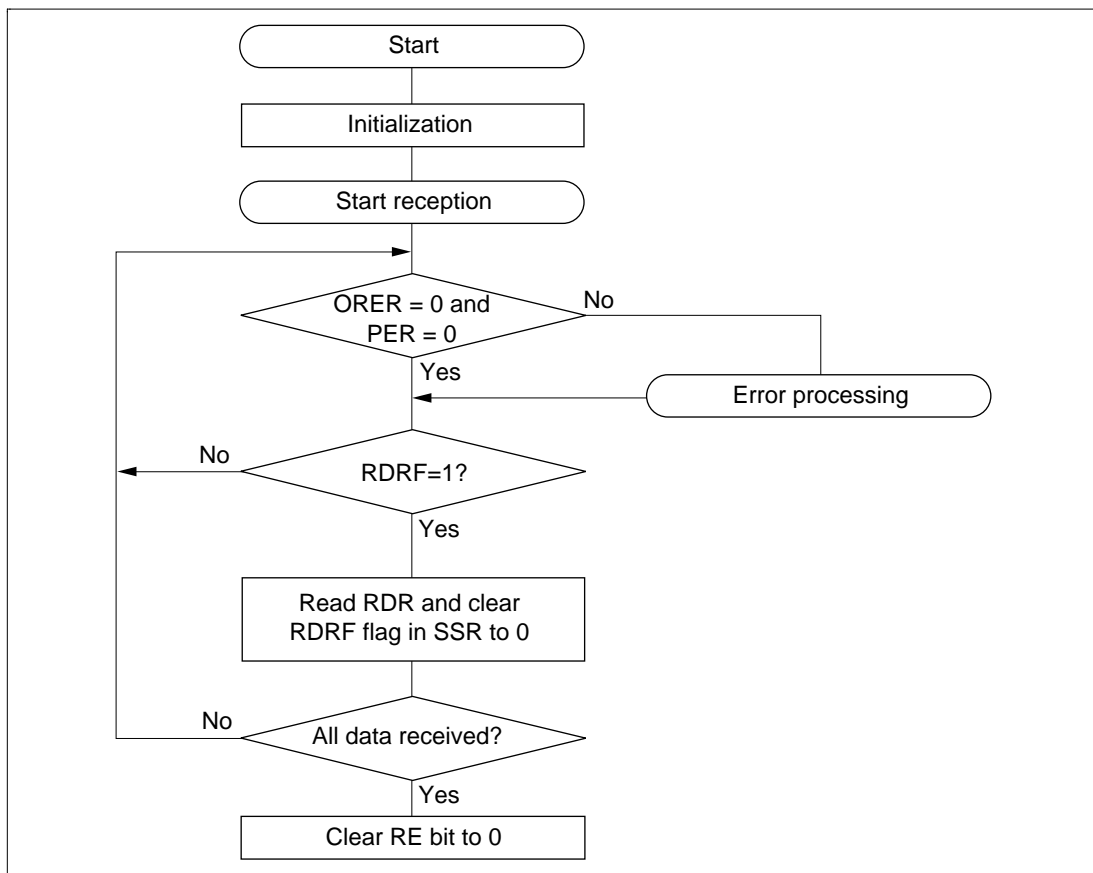

Figure 13-7 Example of Reception Processing Flow

With the above processing, interrupt servicing or data transfer by the DTC is possible.

If reception ends and the RDRF flag is set to 1 while the RIE bit is set to 1 and interrupt requests are enabled, a receive data full interrupt (RXI) request will be generated. If an error occurs in reception and either the ORER flag or the PER flag is set to 1, a transfer error interrupt (ERI) request will be generated.

If the DTC is activated by an RXI request, the receive data in which the error occurred is skipped, and only the number of bytes of receive data set in the DTC are transferred.

For details, see Interrupt Operation and Data Transfer Operation by DTC below.

If a parity error occurs during reception and the PER is set to 1, the received data is still transferred to RDR, and therefore this data can be read.

Mode Switching Operation: When switching from receive mode to transmit mode, first confirm that the receive operation has been completed, then start from initialization, clearing RE bit to 0 and setting TE bit to 1. The RDRF flag or the PER and ORER flags can be used to check that the receive operation has been completed.

When switching from transmit mode to receive mode, first confirm that the transmit operation has been completed, then start from initialization, clearing TE bit to 0 and setting RE bit to 1. The TEND flag can be used to check that the transmit operation has been completed.

Fixing Clock Output Level: When the GSM bit in SMR is set to 1, the clock output level can be fixed with bits CKE1 and CKE0 in SCR. At this time, the minimum clock pulse width can be made the specified width.

Figure 13-8 shows the timing for fixing the clock output level. In this example, GSM is set to 1, CKE1 is cleared to 0, and the CKE0 bit is controlled.

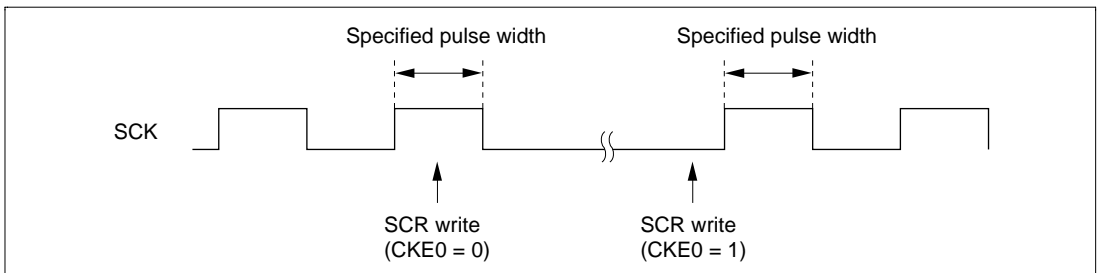

Figure 13-8 Timing for Fixing Clock Output Level

Interrupt Operation: There are three interrupt sources in smart card interface mode: transmit data empty interrupt (TXI) requests, transfer error interrupt (ERI) requests, and receive data full interrupt (RXI) requests. The transmit end interrupt (TEI) request is not used in this mode.

When the TEND flag in SSR is set to 1, a TXI interrupt request is generated.

When the RDRF flag in SSR is set to 1, an RXI interrupt request is generated.

When any of flags ORER, PER, and ERS in SSR is set to 1, an ERI interrupt request is generated. The relationship between the operating states and interrupt sources is shown in table 13-8.

Table 13-8 Smart Card Mode Operating States and Interrupt Sources

Operating State		Flag	Enable Bit	Interrupt Source	DMAC Activation	DTC Activation
Transmit Mode	Normal operation	TEND	TIE	TXI	Possible	Possible
	Error	ERS	RIE	ERI	Not possible	Not possible
Receive Mode	Normal operation	RDRF	RIE	RXI	Possible	Possible
	Error	PER, ORER	RIE	ERI	Not possible	Not possible

Data Transfer Operation by DTC: In smart card mode, as with the normal SCI, transfer can be carried out using the DTC. In a transmit operation, the TDRE flag is also set to 1 at the same time as the TEND flag in SSR, and a TXI interrupt is generated. If the TXI request is designated beforehand as a DTC activation source, the DTC will be activated by the TXI request, and transfer of the transmit data will be carried out. The TDRE and TEND flags are automatically cleared to 0 when data transfer is performed by the DTC. In the event of an error, the SCI retransmits the same data automatically. However, the ERS flag is not cleared automatically when an error occurs, and so the RIE bit should be set to 1 beforehand so that an ERI request will be generated in the event of an error, and the ERS flag will be cleared.

When performing transfer using the DTC, it is essential to set and enable the DTC before carrying out SCI setting. For details of the DTC setting procedures, see section 7, Data Transfer Controller (DTC).

In a receive operation, an RXI interrupt request is generated when the RDRF flag in SSR is set to 1. If the RXI request is designated beforehand as a DTC activation source, the DTC will be activated by the RXI request, and transfer of the receive data will be carried out. The RDRF flag is cleared to 0 automatically when data transfer is performed by the DTC. If an error occurs, an error flag is set but the RDRF flag is not. Consequently, the DTC is not activated, but instead, an ERI interrupt request is sent to the CPU. Therefore, the error flag should be cleared.

13.3.7 Operation in GSM Mode

Switching the Mode: When switching between smart card interface mode and software standby mode, the following switching procedure should be followed in order to maintain the clock duty.

- When changing from smart card interface mode to software standby mode
 - [1] Set the data register (DR) and data direction register (DDR) corresponding to the SCK pin to the value for the fixed output state in software standby mode.
 - [2] Write 0 to the TE bit and RE bit in the serial control register (SCR) to halt transmit/receive operation. At the same time, set the CKE1 bit to the value for the fixed output state in software standby mode.
 - [3] Write 0 to the CKE0 bit in SCR to halt the clock.
 - [4] Wait for one serial clock period.
During this interval, clock output is fixed at the specified level, with the duty preserved.
 - [5] Write H'00 to SMR and SCMR.
 - [6] Make the transition to the software standby state.
- When returning to smart card interface mode from software standby mode
 - [7] Exit the software standby state.
 - [8] Set the CKE1 bit in SCR to the value for the fixed output state (current SCK pin state) when software standby mode is initiated.
 - [9] Set smart card interface mode and output the clock. Signal generation is started with the normal duty.

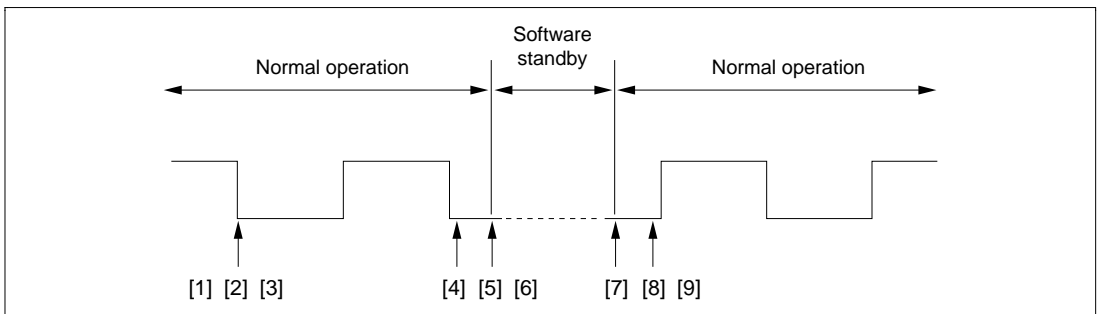

Figure 13-9 Clock Halt and Restart Procedure

Powering On: To secure the clock duty from power-on, the following switching procedure should be followed.

- [1] The initial state is port input and high impedance. Use a pull-up resistor or pull-down resistor to fix the potential.
- [2] Fix the SCK pin to the specified output level with the CKE1 bit in SCR.
- [3] Set SMR and SCMR, and switch to smart card mode operation.
- [4] Set the CKE0 bit in SCR to 1 to start clock output.

13.4 Usage Notes

The following points should be noted when using the SCI as a Smart Card interface.

Receive Data Sampling Timing and Reception Margin in Smart Card Interface Mode: In Smart Card Interface mode, the SCI operates on a basic clock with a frequency of 372 times the transfer rate.

In reception, the SCI samples the falling edge of the start bit using the basic clock, and performs internal synchronization. Receive data is latched internally at the rising edge of the 186th pulse of the basic clock. This is illustrated in figure 13-10.

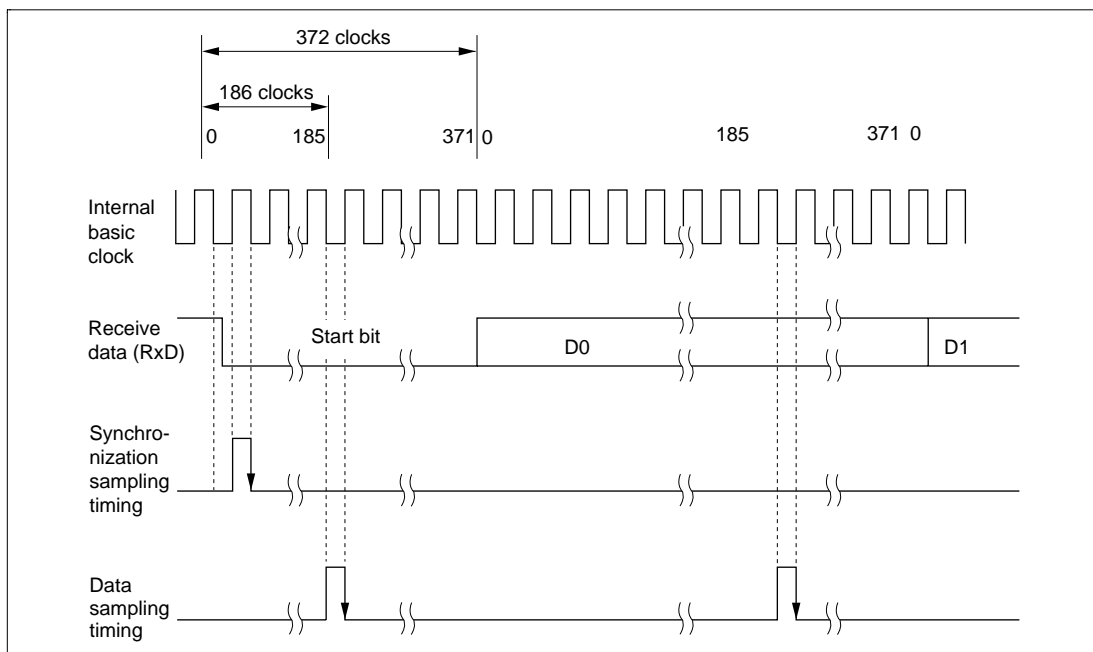

Figure 13-10 Receive Data Sampling Timing in Smart Card Mode

Thus the reception margin in asynchronous mode is given by the following formula.

$$M = \left| \left(0.5 - \frac{1}{2N} \right) - (L - 0.5) F - \frac{|D - 0.5|}{N} (1 + F) \right| \times 100\%$$

Where M: Reception margin (%)

N: Ratio of bit rate to clock (N = 372)

D: Clock duty (D = 0 to 1.0)

L: Frame length (L = 10)

F: Absolute value of clock frequency deviation

Assuming values of F = 0 and D = 0.5 in the above formula, the reception margin formula is as follows.

When D = 0.5 and F = 0,

$$\begin{aligned} M &= (0.5 - 1/2 \times 372) \times 100\% \\ &= 49.866\% \end{aligned}$$

Retransfer Operations: Retransfer operations are performed by the SCI in receive mode and transmit mode as described below.

- Retransfer operation when SCI is in receive mode

Figure 13-11 illustrates the retransfer operation when the SCI is in receive mode.

- [1] If an error is found when the received parity bit is checked, the PER bit in SSR is automatically set to 1. If the RIE bit in SCR is enabled at this time, an ERI interrupt request is generated. The PER bit in SSR should be kept cleared to 0 until the next parity bit is sampled.
- [2] The RDRF bit in SSR is not set for a frame in which an error has occurred.
- [3] If no error is found when the received parity bit is checked, the PER bit in SSR is not set to 1.
- [4] If no error is found when the received parity bit is checked, the receive operation is judged to have been completed normally, and the RDRF flag in SSR is automatically set to 1. If the RIE bit in SCR is enabled at this time, an RXI interrupt request is generated.
If DTC data transfer by an RXI source is enabled, the contents of RDR can be read automatically. When the RDR data is read by the DTC, the RDRF flag is automatically cleared to 0.
- [5] When a normal frame is received, the pin retains the high-impedance state at the timing for error signal transmission.

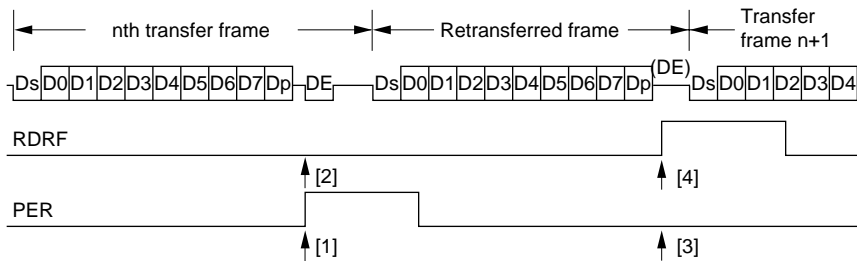

Figure 13-11 Retransfer Operation in SCI Receive Mode

- Retransfer operation when SCI is in transmit mode

Figure 13-12 illustrates the retransfer operation when the SCI is in transmit mode.

[6] If an error signal is sent back from the receiving end after transmission of one frame is completed, the ERS bit in SSR is set to 1. If the RIE bit in SCR is enabled at this time, an ERI interrupt request is generated. The ERS bit in SSR should be kept cleared to 0 until the next parity bit is sampled.

[7] The TEND bit in SSR is not set for a frame for which an error signal indicating an abnormality is received.

[8] If an error signal is not sent back from the receiving end, the ERS bit in SSR is not set.

[9] If an error signal is not sent back from the receiving end, transmission of one frame, including a retransfer, is judged to have been completed, and the TEND bit in SSR is set to 1. If the TIE bit in SCR is enabled at this time, a TXI interrupt request is generated.

If data transfer by the DTC by means of the TXI source is enabled, the next data can be written to TDR automatically. When data is written to TDR by the DTC, the TDRE bit is automatically cleared to 0.

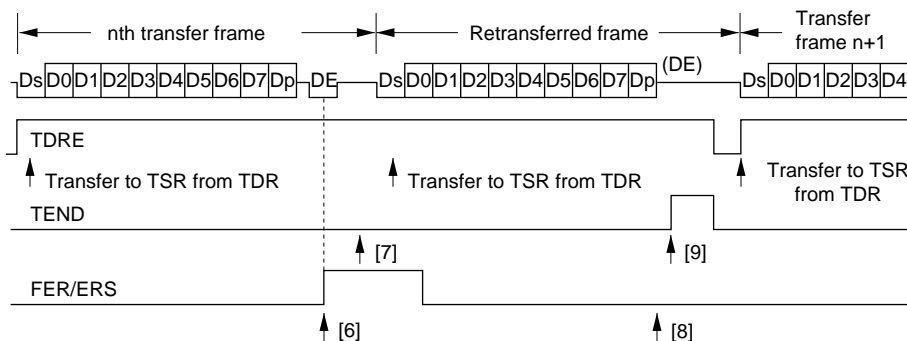

Figure 13-12 Retransfer Operation in SCI Transmit Mode

Section 14 A/D Converter

14.1 Overview

The H8S/2355 Series incorporates a successive approximation type 10-bit A/D converter that allows up to eight analog input channels to be selected.

14.1.1 Features

A/D converter features are listed below

- 10-bit resolution
- Eight input channels
- Settable analog conversion voltage range
 - Conversion of analog voltages with the reference voltage pin (V_{ref}) as the analog reference voltage
- High-speed conversion
 - Minimum conversion time: 6.7 μ s per channel (at 20 MHz operation)
- Choice of single mode or scan mode
 - Single mode: Single-channel A/D conversion
 - Scan mode: Continuous A/D conversion on 1 to 4 channels
- Four data registers
 - Conversion results are held in a 16-bit data register for each channel
- Sample and hold function
- Three kinds of conversion start
 - Choice of software or timer conversion start trigger (TPU or 8-bit timer), or \overline{ADTRG} pin
- A/D conversion end interrupt generation
 - A/D conversion end interrupt (ADI) request can be generated at the end of A/D conversion
- Module stop mode can be set
 - As the initial setting, A/D converter operation is halted. Register access is enabled by exiting module stop mode.

14.1.2 Block Diagram

Figure 14-1 shows a block diagram of the A/D converter.

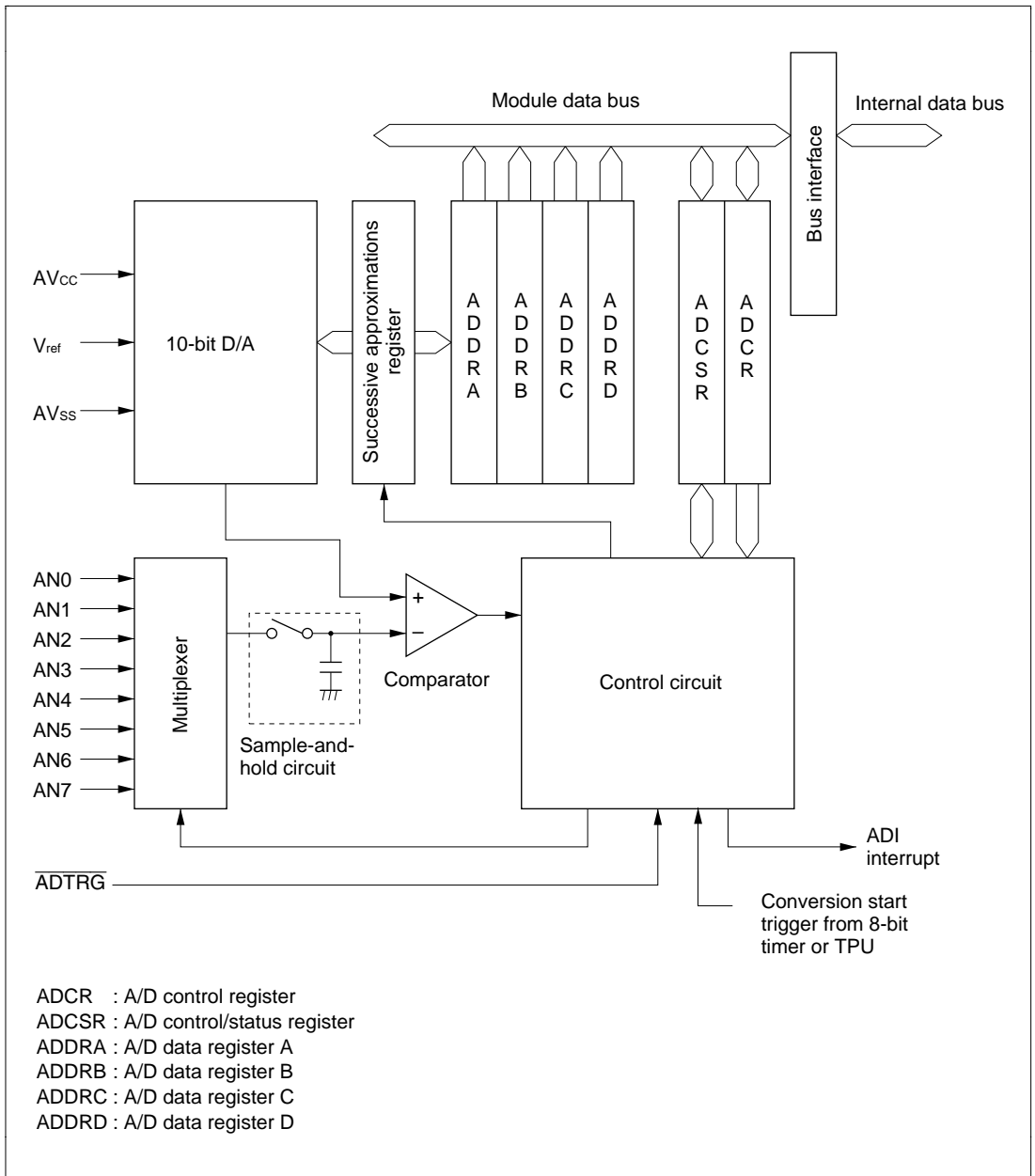

Figure 14-1 Block Diagram of A/D Converter

14.1.3 Pin Configuration

Table 14-1 summarizes the input pins used by the A/D converter.

The AV_{CC} and AV_{SS} pins are the power supply pins for the analog block in the A/D converter. The V_{ref} pin is the A/D conversion reference voltage pin.

The eight analog input pins are divided into two groups: group 0 (AN0 to AN3), and group 1 (AN4 to AN7).

Table 14-1 A/D Converter Pins

Pin Name	Symbol	I/O	Function
Analog power supply pin	AV_{CC}	Input	Analog block power supply
Analog ground pin	AV_{SS}	Input	Analog block ground and A/D conversion reference voltage
Reference voltage pin	V_{ref}	Input	A/D conversion reference voltage
Analog input pin 0	AN0	Input	Group 0 analog inputs
Analog input pin 1	AN1	Input	
Analog input pin 2	AN2	Input	
Analog input pin 3	AN3	Input	
Analog input pin 4	AN4	Input	Group 1 analog inputs
Analog input pin 5	AN5	Input	
Analog input pin 6	AN6	Input	
Analog input pin 7	AN7	Input	
A/D external trigger input pin	\overline{ADTRG}	Input	External trigger input for starting A/D conversion

14.1.4 Register Configuration

Table 14-2 summarizes the registers of the A/D converter.

Table 14-2 A/D Converter Registers

Name	Abbreviation	R/W	Initial Value	Address*¹
A/D data register AH	ADDRAH	R	H'00	H'FF90
A/D data register AL	ADDRAL	R	H'00	H'FF91
A/D data register BH	ADDRBH	R	H'00	H'FF92
A/D data register BL	ADDRBL	R	H'00	H'FF93
A/D data register CH	ADDRCH	R	H'00	H'FF94
A/D data register CL	ADDRCL	R	H'00	H'FF95
A/D data register DH	ADDRDH	R	H'00	H'FF96
A/D data register DL	ADDRDL	R	H'00	H'FF97
A/D control/status register	ADCSR	R/(W)* ²	H'00	H'FF98
A/D control register	ADCR	R/W	H'3F	H'FF99
Module stop control register	MSTPCR	R/W	H'3FFF	H'FF3C

Notes: 1. Lower 16 bits of the address.

2. Bit 7 can only be written with 0 for flag clearing.

14.2 Register Descriptions

14.2.1 A/D Data Registers A to D (ADDRA to ADDR D)

Bit	:	15	14	13	12	11	10	9	8	7	6	5	4	3	2	1	0
		AD9	AD8	AD7	AD6	AD5	AD4	AD3	AD2	AD1	AD0	—	—	—	—	—	—
Initial value	:	0	0	0	0	0	0	0	0	0	0	0	0	0	0	0	0
R/W	:	R	R	R	R	R	R	R	R	R	R	R	R	R	R	R	R

There are four 16-bit read-only ADDR registers, ADDRA to ADDR D, used to store the results of A/D conversion.

The 10-bit data resulting from A/D conversion is transferred to the ADDR register for the selected channel and stored there. The upper 8 bits of the converted data are transferred to the upper byte (bits 15 to 8) of ADDR, and the lower 2 bits are transferred to the lower byte (bits 7 and 6) and stored. Bits 5 to 0 are always read as 0.

The correspondence between the analog input channels and ADDR registers is shown in table 14-3.

ADDR can always be read by the CPU. The upper byte can be read directly, but for the lower byte, data transfer is performed via a temporary register (TEMP). For details, see section 14.3, Interface to Bus Master.

The ADDR registers are initialized to H'0000 by a reset, and in standby mode or module stop mode.

Table 14-3 Analog Input Channels and Corresponding ADDR Registers

Analog Input Channel		A/D Data Register
Group 0	Group 1	
AN0	AN4	ADDRA
AN1	AN5	ADDRB
AN2	AN6	ADDRC
AN3	AN7	ADDRD

14.2.2 A/D Control/Status Register (ADCSR)

Bit	:	7	6	5	4	3	2	1	0
		ADF	ADIE	ADST	SCAN	CKS	CH2	CH1	CH0
Initial value	:	0	0	0	0	0	0	0	0
R/W	:	R/(W)*	R/W	R/W	R/W	R/W	R/W	R/W	R/W

Note: * Only 0 can be written to bit 7, to clear this flag.

ADCSR is an 8-bit readable/writable register that controls A/D conversion operations and shows the status of the operation.

ADCSR is initialized to H'00 by a reset, and in hardware standby mode or module stop mode.

Bit 7—A/D End Flag (ADF): Status flag that indicates the end of A/D conversion.

Bit 7

ADF	Description
0	[Clearing conditions] (Initial value) <ul style="list-style-type: none">• When 0 is written to the ADF flag after reading ADF = 1• When the DTC is activated by an ADI interrupt and ADDR is read
1	[Setting conditions] <ul style="list-style-type: none">• Single mode: When A/D conversion ends• Scan mode: When A/D conversion ends on all specified channels

Bit 6—A/D Interrupt Enable (ADIE): Selects enabling or disabling of interrupt (ADI) requests at the end of A/D conversion.

Bit 6

ADIE	Description
0	A/D conversion end interrupt (ADI) request disabled (Initial value)
1	A/D conversion end interrupt (ADI) request enabled

Bit 5—A/D Start (ADST): Selects starting or stopping on A/D conversion. Holds a value of 1 during A/D conversion.

The ADST bit can be set to 1 by software, a timer conversion start trigger, or the A/D external trigger input pin (ADTRG).

Bit 5

ADST	Description
0	• A/D conversion stopped (Initial value)
1	• Single mode: A/D conversion is started. Cleared to 0 automatically when conversion on the specified channel ends • Scan mode: A/D conversion is started. Conversion continues sequentially on the selected channels until ADST is cleared to 0 by software, a reset, or a transition to standby mode or module stop mode.

Bit 4—Scan Mode (SCAN): Selects single mode or scan mode as the A/D conversion operating mode. See section 14.4, Operation, for single mode and scan mode operation. Only set the SCAN bit while conversion is stopped (ADST = 0).

Bit 4

SCAN	Description
0	Single mode (Initial value)
1	Scan mode

Bit 3—Clock Select (CKS): Sets the A/D conversion time. Only change the conversion time while conversion is stopped (ADST = 0).

Bit 3

CKS	Description
0	Conversion time = 266 states (max.) (Initial value)
1	Conversion time = 134 states (max.)

Bits 2 to 0—Channel Select 2 to 0 (CH2 to CH0): Together with the SCAN bit, these bits select the analog input channels.

Only set the input channel while conversion is stopped (ADST = 0).

Group Selection	Channel Selection		Description	
CH2	CH1	CH0	Single Mode	Scan Mode
0	0	0	AN0 (Initial value)	AN0
		1	AN1	AN0, AN1
	1	0	AN2	AN0 to AN2
		1	AN3	AN0 to AN3
1	0	0	AN4	AN4
		1	AN5	AN4, AN5
	1	0	AN6	AN4 to AN6
		1	AN7	AN4 to AN7

14.2.3 A/D Control Register (ADCR)

Bit	:	7	6	5	4	3	2	1	0
		TRGS1	TRGS0	—	—	—	—	—	—
Initial value	:	0	0	1	1	1	1	1	1
R/W	:	R/W	R/W	—	—	—	—	—	—

ADCR is an 8-bit readable/writable register that enables or disables external triggering of A/D conversion operations.

ADCR is initialized to H'3F by a reset, and in standby mode or module stop mode.

Bits 7 and 6—Timer Trigger Select 1 and 0 (TRGS1, TRGS0): Select enabling or disabling of the start of A/D conversion by a trigger signal. Only set bits TRGS1 and TRGS0 while conversion is stopped (ADST = 0).

Bit 7	Bit 6	Description
TRGS1	TRGS0	
0	0	A/D conversion start by external trigger is disabled (Initial value)
	1	A/D conversion start by external trigger (TPU) is enabled
1	0	A/D conversion start by external trigger (8-bit timer) is enabled
	1	A/D conversion start by external trigger pin ($\overline{\text{ADTRG}}$) is enabled

Bits 5 to 0—Reserved: These bits are reserved; they are always read as 1 and cannot be modified.

14.2.4 Module Stop Control Register (MSTPCR)

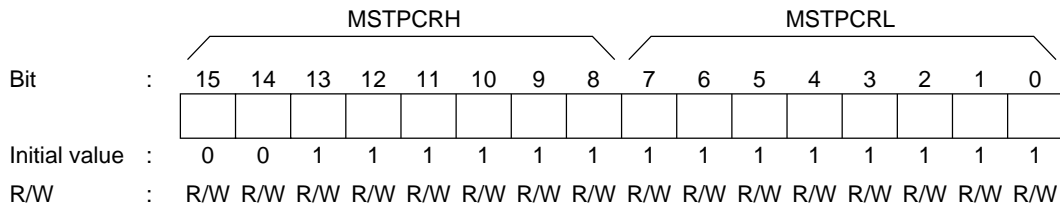

MSTPCR is a 16-bit readable/writable register that performs module stop mode control.

When the MSTP9 bit in MSTPCR is set to 1, A/D converter operation stops at the end of the bus cycle and a transition is made to module stop mode. Registers cannot be read or written to in module stop mode. For details, see section 19.5, Module Stop Mode.

MSTPCR is initialized to H'3FFF by a reset and in hardware standby mode. It is not initialized in software standby mode.

Bit 9—Module Stop (MSTP9): Specifies the A/D converter module stop mode.

Bit 9

MSTP9	Description
0	A/D converter module stop mode cleared
1	A/D converter module stop mode set (Initial value)

14.3 Interface to Bus Master

ADDRA to ADDR_D are 16-bit registers, and the data bus to the bus master is 8 bits wide. Therefore, in accesses by the bus master, the upper byte is accessed directly, but the lower byte is accessed via a temporary register (TEMP).

A data read from ADDR is performed as follows. When the upper byte is read, the upper byte value is transferred to the CPU and the lower byte value is transferred to TEMP. Next, when the lower byte is read, the TEMP contents are transferred to the CPU.

When reading ADDR, always read the upper byte before the lower byte. It is possible to read only the upper byte, but if only the lower byte is read, incorrect data may be obtained.

Figure 14-2 shows the data flow for ADDR access.

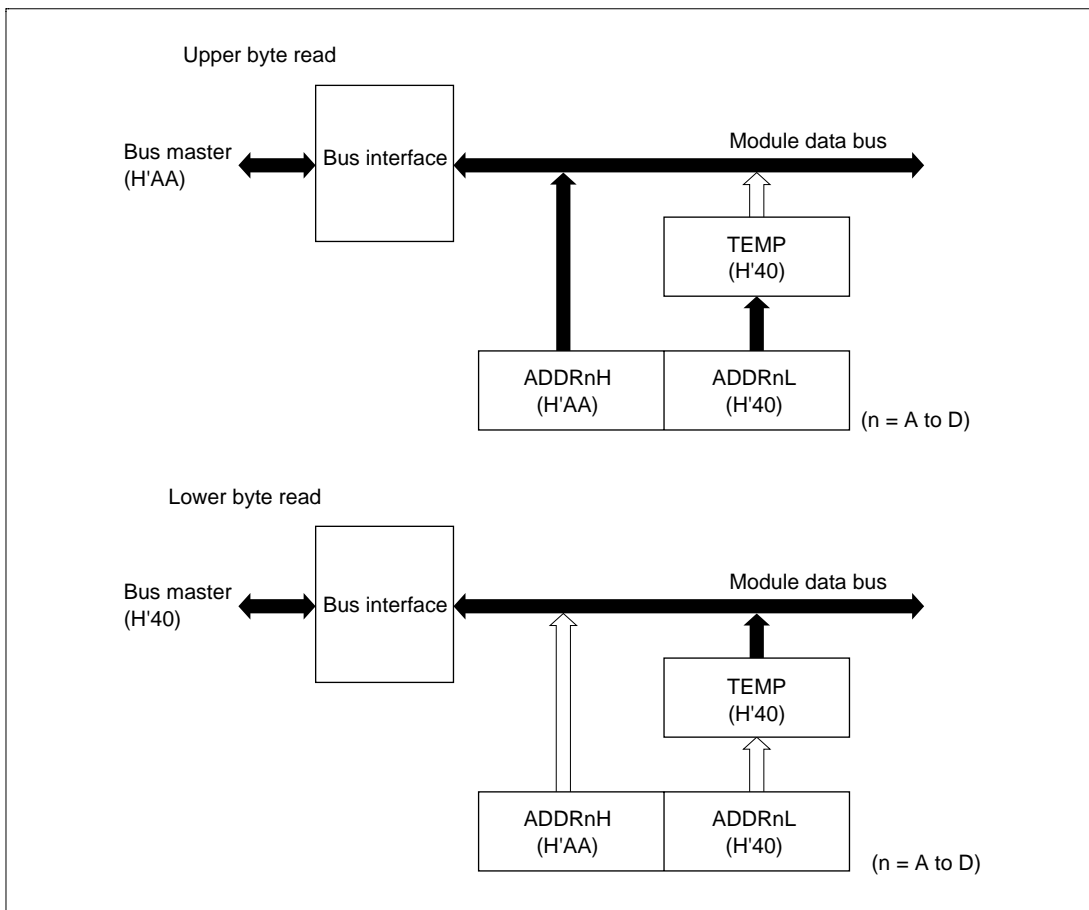

Figure 14-2 ADDR Access Operation (Reading H'AA40)

14.4 Operation

The A/D converter operates by successive approximation with 10-bit resolution. It has two operating modes: single mode and scan mode.

14.4.1 Single Mode (SCAN = 0)

Single mode is selected when A/D conversion is to be performed on a single channel only. A/D conversion is started when the ADST bit is set to 1, according to the software or external trigger input. The ADST bit remains set to 1 during A/D conversion, and is automatically cleared to 0 when conversion ends.

On completion of conversion, the ADF flag is set to 1. If the ADIE bit is set to 1 at this time, an ADI interrupt request is generated. The ADF flag is cleared by writing 0 after reading ADCSR.

When the operating mode or analog input channel must be changed during analog conversion, to prevent incorrect operation, first clear the ADST bit to 0 in ADCSR to halt A/D conversion. After making the necessary changes, set the ADST bit to 1 to start A/D conversion again. The ADST bit can be set at the same time as the operating mode or input channel is changed.

Typical operations when channel 1 (AN1) is selected in single mode are described next. Figure 14-3 shows a timing diagram for this example.

- [1] Single mode is selected (SCAN = 0), input channel AN1 is selected (CH2 = 0, CH1 = 0, CH0 = 1), the A/D interrupt is enabled (ADIE = 1), and A/D conversion is started (ADST = 1).
- [2] When A/D conversion is completed, the result is transferred to ADDR1. At the same time the ADF flag is set to 1, the ADST bit is cleared to 0, and the A/D converter becomes idle.
- [3] Since ADF = 1 and ADIE = 1, an ADI interrupt is requested.
- [4] The A/D interrupt handling routine starts.
- [5] The routine reads ADCSR, then writes 0 to the ADF flag.
- [6] The routine reads and processes the conversion result (ADDR1).
- [7] Execution of the A/D interrupt handling routine ends. After that, if the ADST bit is set to 1, A/D conversion starts again and steps [2] to [7] are repeated.

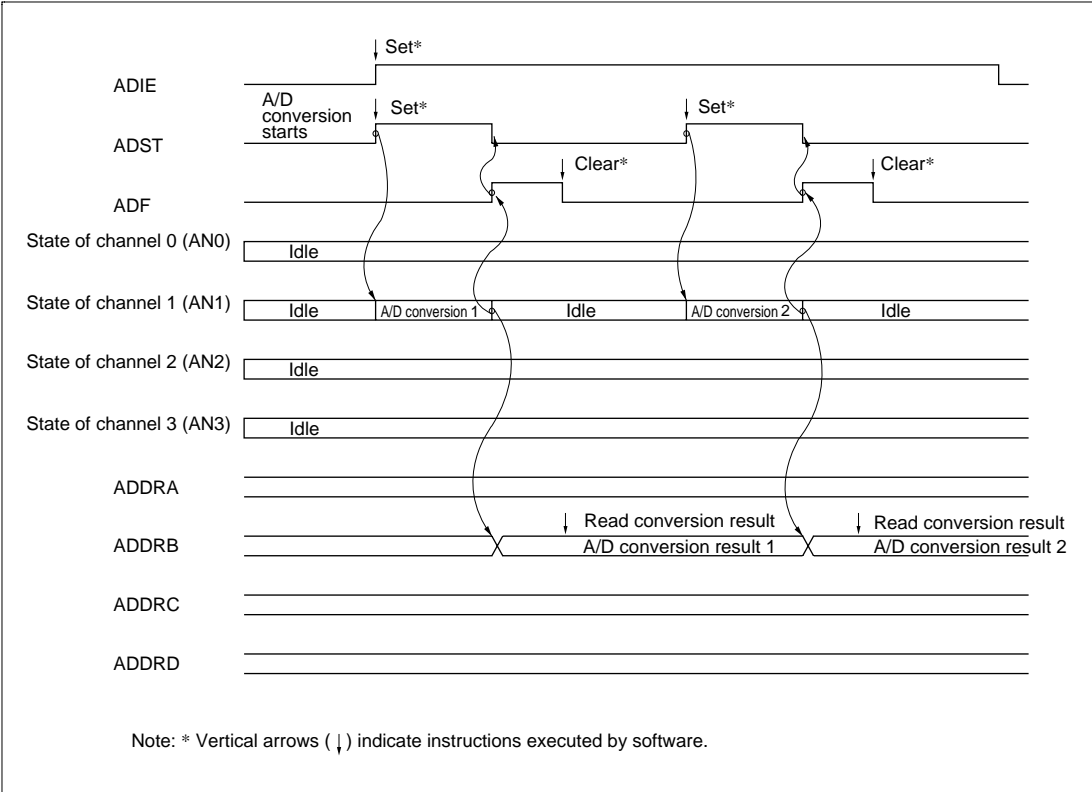

Figure 14-3 Example of A/D Converter Operation (Single Mode, Channel 1 Selected)

14.4.2 Scan Mode (SCAN = 1)

Scan mode is useful for monitoring analog inputs in a group of one or more channels. When the ADST bit is set to 1 by a software, timer or external trigger input, A/D conversion starts on the first channel in the group (AN0). When two or more channels are selected, after conversion of the first channel ends, conversion of the second channel (AN1) starts immediately. A/D conversion continues cyclically on the selected channels until the ADST bit is cleared to 0. The conversion results are transferred for storage into the ADDR registers corresponding to the channels.

When the operating mode or analog input channel must be changed during analog conversion, to prevent incorrect operation, first clear the ADST bit to 0 in ADCSR to halt A/D conversion. After making the necessary changes, set the ADST bit to 1 to start A/D conversion again. The ADST bit can be set at the same time as the operating mode or input channel is changed.

Typical operations when three channels (AN0 to AN2) are selected in scan mode are described next. Figure 14-4 shows a timing diagram for this example.

- [1] Scan mode is selected (SCAN = 1), scan group 0 is selected (CH2 = 0), analog input channels AN0 to AN2 are selected (CH1 = 1, CH0 = 0), and A/D conversion is started (ADST = 1)
- [2] When A/D conversion of the first channel (AN0) is completed, the result is transferred to ADDR0. Next, conversion of the second channel (AN1) starts automatically.
- [3] Conversion proceeds in the same way through the third channel (AN2).
- [4] When conversion of all the selected channels (AN0 to AN2) is completed, the ADF flag is set to 1 and conversion of the first channel (AN0) starts again. If the ADIE bit is set to 1 at this time, an ADI interrupt is requested after A/D conversion ends.
- [5] Steps [2] to [4] are repeated as long as the ADST bit remains set to 1. When the ADST bit is cleared to 0, A/D conversion stops. After that, if the ADST bit is set to 1, A/D conversion starts again from the first channel (AN0).

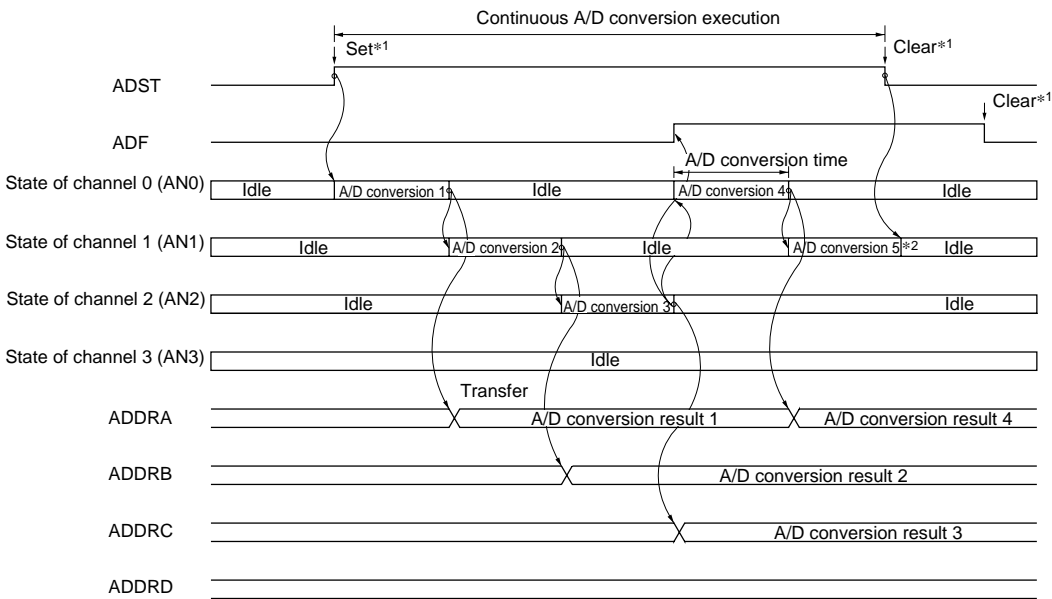

- Notes: 1. Vertical arrows (↓) indicate instructions executed by software.
 2. Data currently being converted is ignored.

**Figure 14-4 Example of A/D Converter Operation
 (Scan Mode, Channels AN0 to AN2 Selected)**

14.4.3 Input Sampling and A/D Conversion Time

The A/D converter has a built-in sample-and-hold circuit. The A/D converter samples the analog input at a time t_D after the ADST bit is set to 1, then starts conversion. Figure 14-5 shows the A/D conversion timing. Table 14-4 indicates the A/D conversion time.

As indicated in figure 14-5, the A/D conversion time includes t_D and the input sampling time. The length of t_D varies depending on the timing of the write access to ADCSR. The total conversion time therefore varies within the ranges indicated in table 14-4.

In scan mode, the values given in table 14-4 apply to the first conversion time. In the second and subsequent conversions the conversion time is fixed at 256 states when $CKS = 0$ or 128 states when $CKS = 1$.

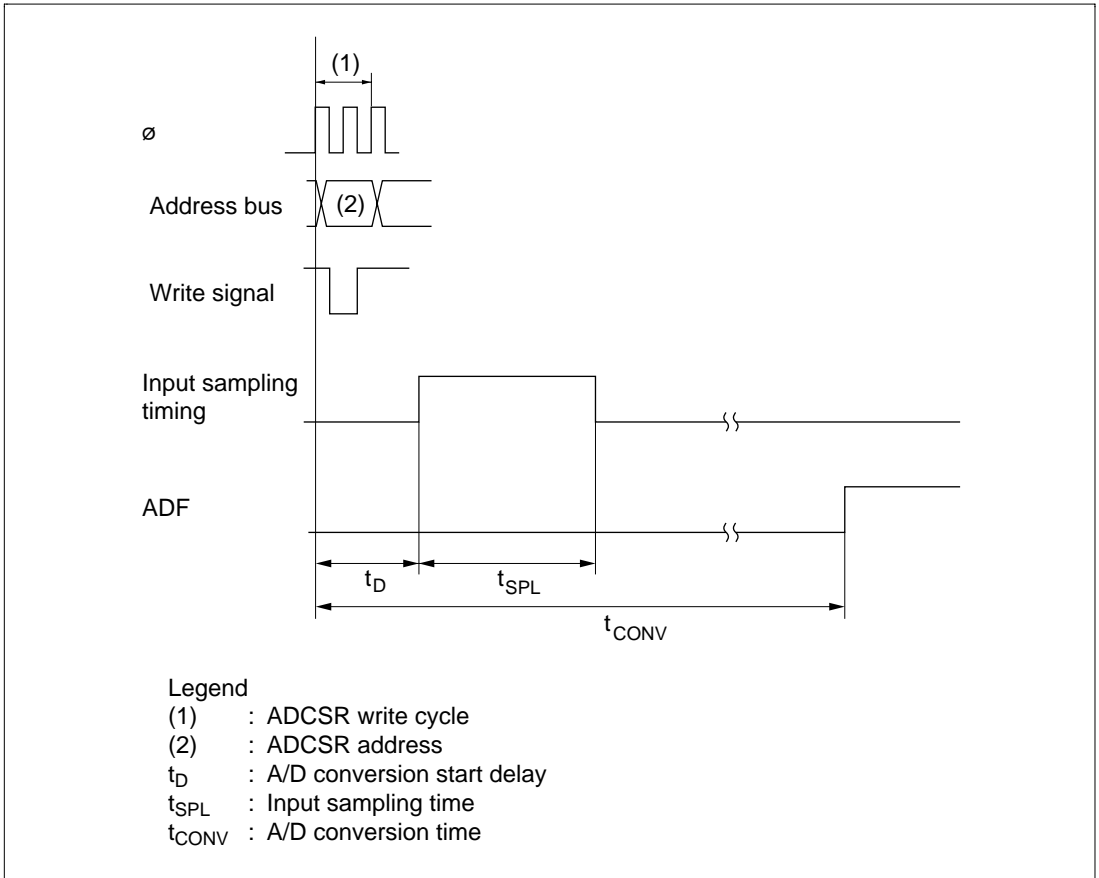

Figure 14-5 A/D Conversion Timing

Table 14-4 A/D Conversion Time (Single Mode)

Item	Symbol	CKS = 0			CKS = 1		
		Min	Typ	Max	Min	Typ	Max
A/D conversion start delay	t_D	10	—	17	6	—	9
Input sampling time	t_{SPL}	—	63	—	—	31	—
A/D conversion time	t_{CONV}	259	—	266	131	—	134

Note: Values in the table are the number of states.

14.4.4 External Trigger Input Timing

A/D conversion can be externally triggered. When the TRGS1 and TRGS0 bits are set to 11 in ADCR, external trigger input is enabled at the \overline{ADTRG} pin. A falling edge at the \overline{ADTRG} pin sets the ADST bit to 1 in ADCSR, starting A/D conversion. Other operations, in both single and scan modes, are the same as if the ADST bit has been set to 1 by software. Figure 14-6 shows the timing.

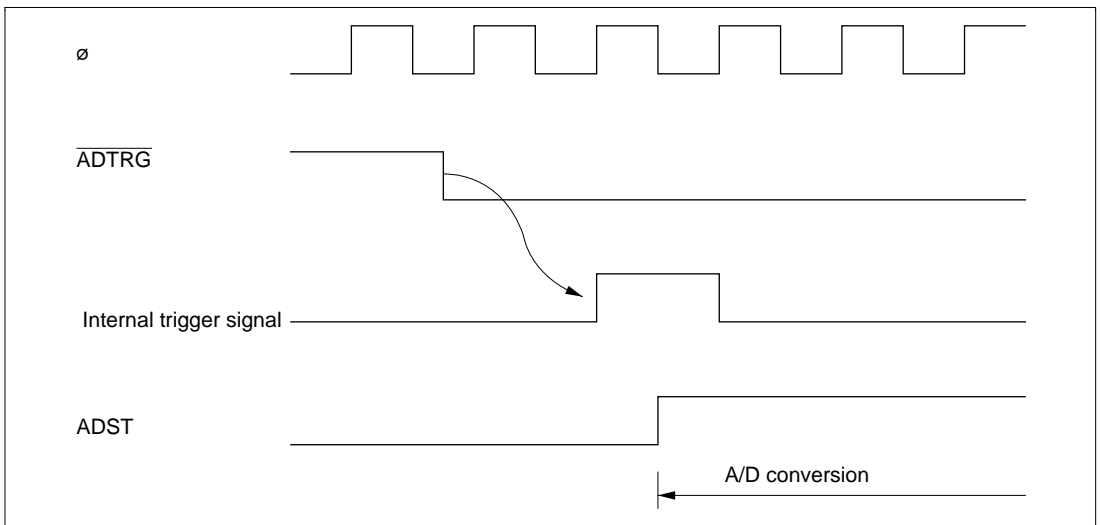

Figure 14-6 External Trigger Input Timing

14.5 Interrupts

The A/D converter generates an A/D conversion end interrupt (ADI) at the end of A/D conversion. ADI interrupt requests can be enabled or disabled by means of the ADIE bit in ADCSR.

The DTC can be activated by an ADI interrupt. Having the converted data read by the DTC in response to an ADI interrupt enables continuous conversion to be achieved without imposing a load on software.

The A/D converter interrupt source is shown in table 14-5.

Table 14-5 A/D Converter Interrupt Source

Interrupt Source	Description	DTC Activation
ADI	Interrupt due to end of conversion	Possible

14.6 Usage Notes

The following points should be noted when using the A/D converter.

Setting Range of Analog Power Supply and Other Pins:

(1) Analog input voltage range

The voltage applied to analog input pins AN0 to AN7 during A/D conversion should be in the range $AV_{SS} \leq ANn \leq V_{ref}$.

(2) Relation between AV_{CC} , AV_{SS} and V_{CC} , V_{SS}

As the relationship between AV_{CC} , AV_{SS} and V_{CC} , V_{SS} , set $AV_{SS} = V_{SS}$. If the A/D converter is not used, the AV_{CC} and AV_{SS} pins must on no account be left open.

(3) V_{ref} input range

The analog reference voltage input at the V_{ref} pin set in the range $V_{ref} \leq AV_{CC}$.

If conditions (1), (2), and (3) above are not met, the reliability of the device may be adversely affected.

Notes on Board Design: In board design, digital circuitry and analog circuitry should be as mutually isolated as possible, and layout in which digital circuit signal lines and analog circuit signal lines cross or are in close proximity should be avoided as far as possible. Failure to do so may result in incorrect operation of the analog circuitry due to inductance, adversely affecting A/D conversion values.

Also, digital circuitry must be isolated from the analog input signals (AN0 to AN7), analog reference power supply (V_{ref}), and analog power supply (AV_{CC}) by the analog ground (AV_{SS}). Also, the analog ground (AV_{SS}) should be connected at one point to a stable digital ground (V_{SS}) on the board.

Notes on Noise Countermeasures: A protection circuit connected to prevent damage due to an abnormal voltage such as an excessive surge at the analog input pins (AN0 to AN7) and analog reference power supply (V_{ref}) should be connected between AV_{CC} and AV_{SS} as shown in figure 14-7.

Also, the bypass capacitors connected to AV_{CC} and V_{ref} and the filter capacitor connected to AN0 to AN7 must be connected to AV_{SS} .

If a filter capacitor is connected as shown in figure 14-7, the input currents at the analog input pins (AN0 to AN7) are averaged, and so an error may arise. Also, when A/D conversion is performed frequently, as in scan mode, if the current charged and discharged by the capacitance of the sample-and-hold circuit in the A/D converter exceeds the current input via the input impedance (R_{in}), an error will arise in the analog input pin voltage. Careful consideration is therefore required when deciding the circuit constants.

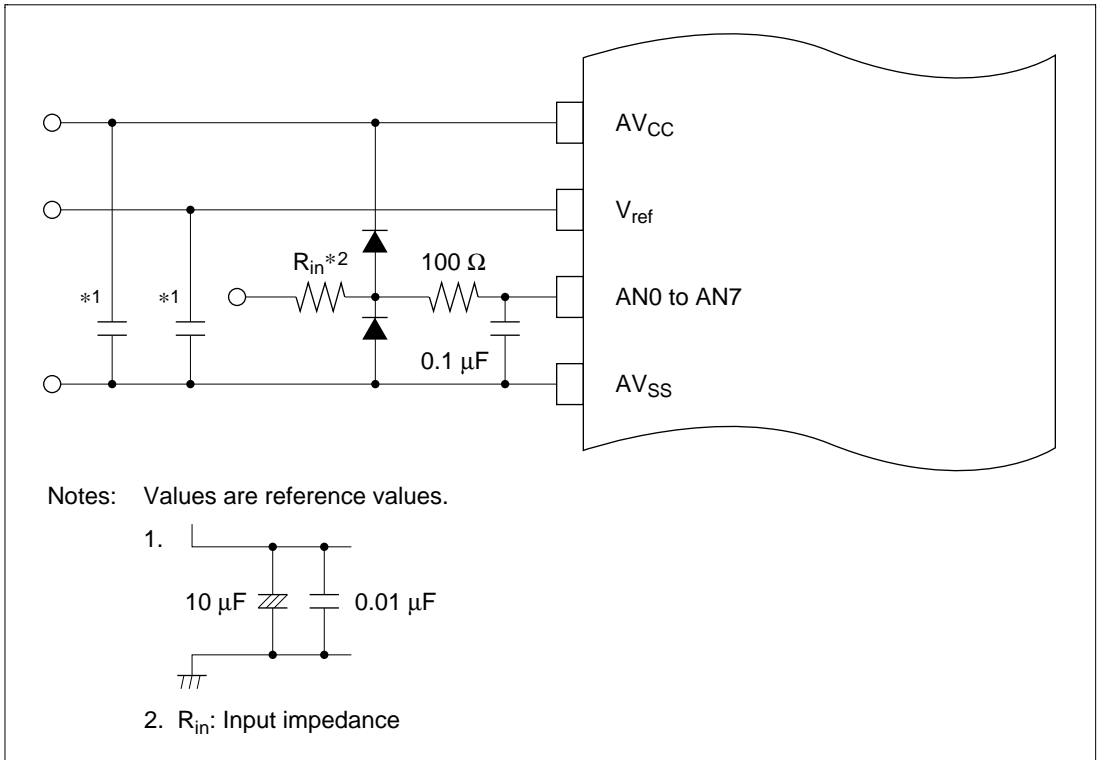
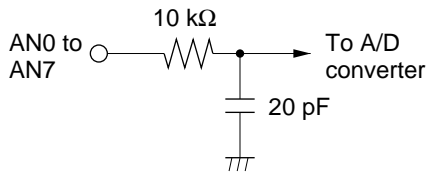

Figure 14-7 Example of Analog Input Protection Circuit



Note: Values are reference values.

Figure 14-8 Analog Input Pin Equivalent Circuit

A/D Conversion Precision Definitions: H8S/2355 Series A/D conversion precision definitions are given below.

- Resolution
The number of A/D converter digital output codes
- Offset error
The deviation of the analog input voltage value from the ideal A/D conversion characteristic when the digital output changes from the minimum voltage value B'000000000 (H'000) to B'000000001 (H'001) (see figure 14-10).
- Full-scale error
The deviation of the analog input voltage value from the ideal A/D conversion characteristic when the digital output changes from B'111111110 (H'3FE) to B'111111111 (H'3FF) (see figure 14-10).
- Quantization error
The deviation inherent in the A/D converter, given by 1/2 LSB (see figure 14-9).
- Nonlinearity error
The error with respect to the ideal A/D conversion characteristic between the zero voltage and the full-scale voltage. Does not include the offset error, full-scale error, or quantization error.
- Absolute precision
The deviation between the digital value and the analog input value. Includes the offset error, full-scale error, quantization error, and nonlinearity error.

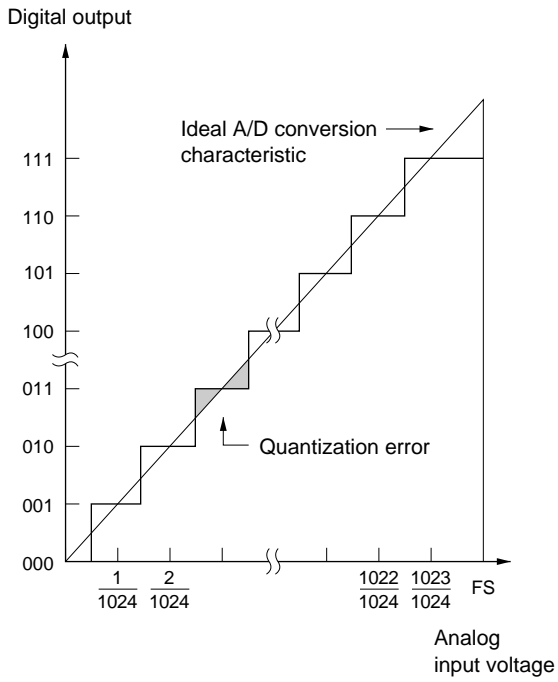

Figure 14-9 A/D Conversion Precision Definitions (1)

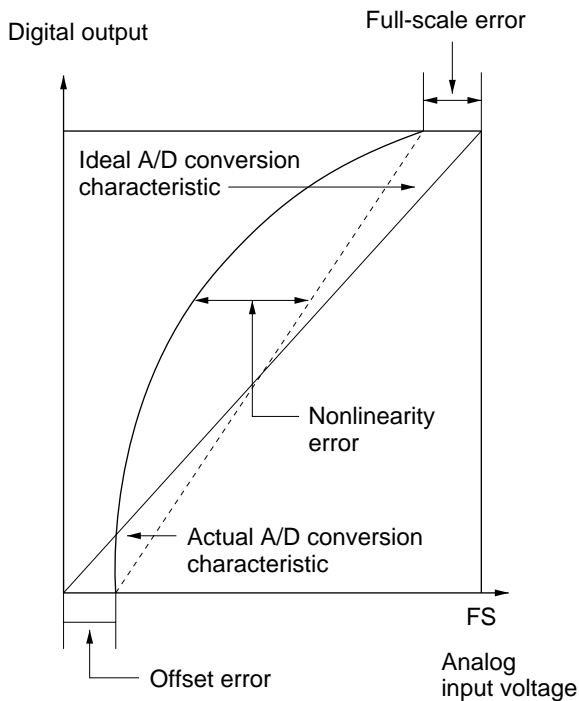

Figure 14-10 A/D Conversion Precision Definitions (2)

Permissible Signal Source Impedance: H8S/2355 Series analog input is designed so that conversion precision is guaranteed for an input signal for which the signal source impedance is 10 k Ω or less. This specification is provided to enable the A/D converter's sample-and-hold circuit input capacitance to be charged within the sampling time; if the sensor output impedance exceeds 10 k Ω , charging may be insufficient and it may not be possible to guarantee the A/D conversion precision.

However, if a large capacitance is provided externally, the input load will essentially comprise only the internal input resistance of 10 k Ω , and the signal source impedance is ignored.

However, since a low-pass filter effect is obtained in this case, it may not be possible to follow an analog signal with a large differential coefficient (e.g., 5 mV/ μ s or greater).

When converting a high-speed analog signal, a low-impedance buffer should be inserted.

Influences on Absolute Precision: Adding capacitance results in coupling with GND, and therefore noise in GND may adversely affect absolute precision. Be sure to make the connection to an electrically stable GND such as AV_{SS} .

Care is also required to insure that filter circuits do not communicate with digital signals on the mounting board, so acting as antennas.

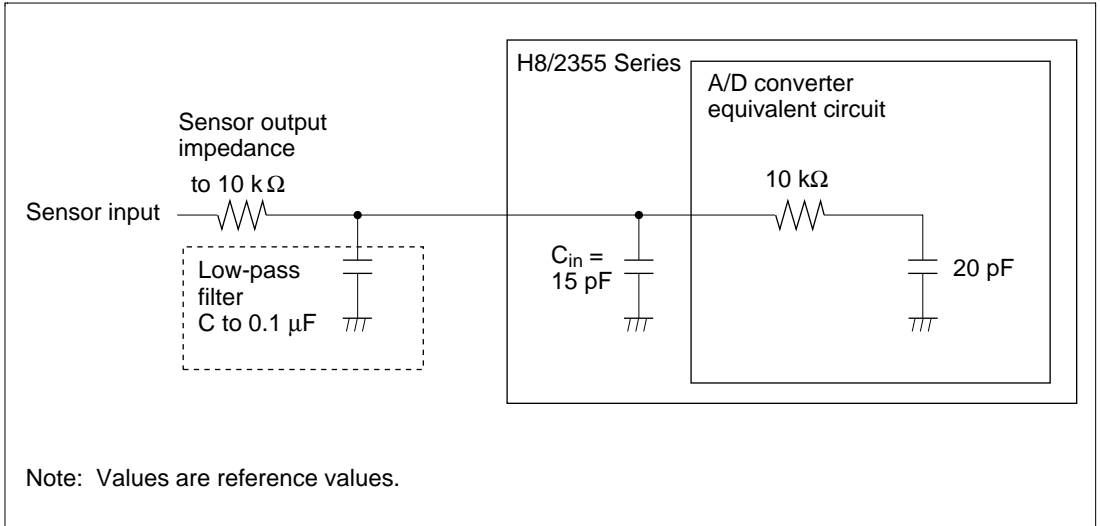

Figure 14-11 Example of Analog Input Circuit

Section 15 D/A Converter (Not supported in H8S/2393)

15.1 Overview

The H8S/2355 and H8S/2353 include a two-channel D/A converter.

15.1.1 Features

D/A converter features are listed below

- 8-bit resolution
- Two output channels
- Maximum conversion time of 10 μ s (with 20 pF load)
- Output voltage of 0 V to V_{ref}
- D/A output hold function in software standby mode
- Module stop mode can be set
 - As the initial setting, D/A converter operation is halted. Register access is enabled by exiting module stop mode.

15.1.2 Block Diagram

Figure 15-1 shows a block diagram of the D/A converter.

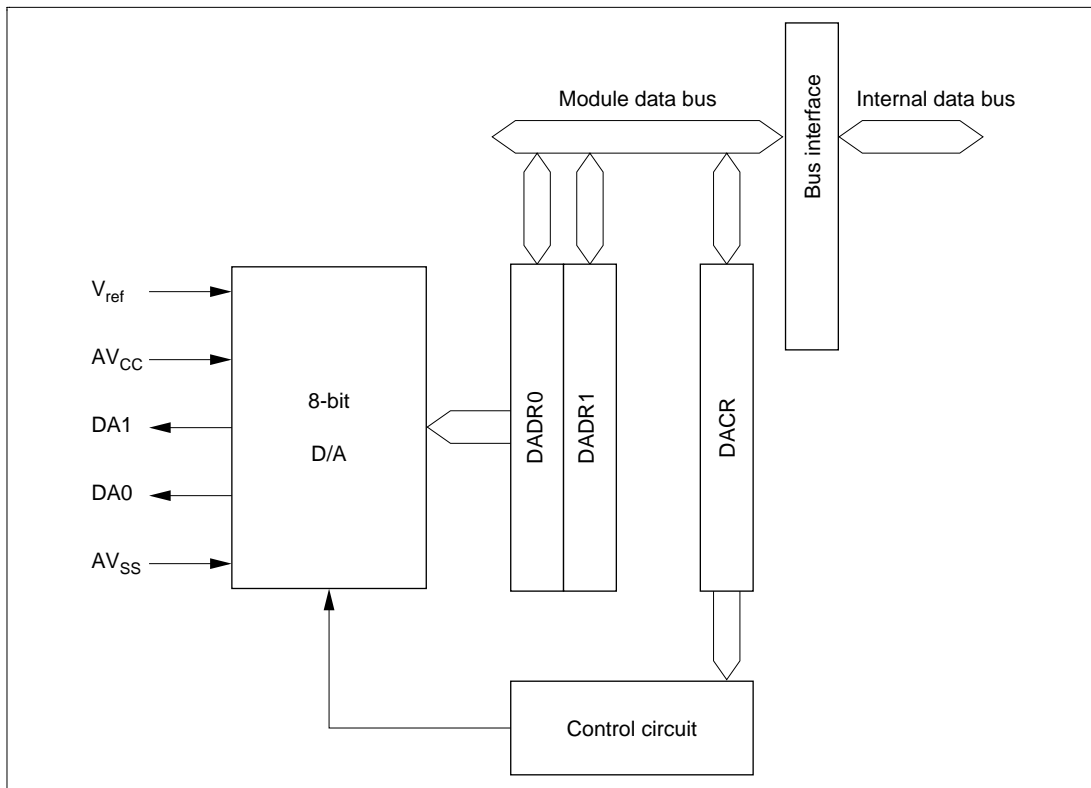

Figure 15-1 Block Diagram of D/A Converter

15.1.3 Pin Configuration

Table 15-1 summarizes the input and output pins of the D/A converter.

Table 15-1 Pin Configuration

Pin Name	Symbol	I/O	Function
Analog power pin	AV_{CC}	Input	Analog power source
Analog ground pin	AV_{SS}	Input	Analog ground and reference voltage
Analog output pin 0	DA0	Output	Channel 0 analog output
Analog output pin 1	DA1	Output	Channel 1 analog output
Reference voltage pin	V_{ref}	Input	Analog reference voltage

15.1.4 Register Configuration

Table 15-2 summarizes the registers of the D/A converter.

Table 15-2 D/A Converter Registers

Name	Abbreviation	R/W	Initial Value	Address*
D/A data register 0	DADR0	R/W	H'00	H'FFA4
D/A data register 1	DADR1	R/W	H'00	H'FFA5
D/A control register	DACR	R/W	H'1F	H'FFA6
Module stop control register	MSTPCR	R/W	H'3FFF	H'FF3C

Note:* Lower 16 bits of the address.

15.2 Register Descriptions

15.2.1 D/A Data Registers 0 and 1 (DADR0, DADR1)

Bit	:	7	6	5	4	3	2	1	0
Initial value:		0	0	0	0	0	0	0	0
R/W	:	R/W	R/W	R/W	R/W	R/W	R/W	R/W	R/W

DADR0 and DADR1 are 8-bit readable/writable registers that store data for conversion.

Whenever output is enabled, the values in DADR0 and DADR1 are converted and output from the analog output pins.

DADR0 and DADR1 are each initialized to H'00 by a reset and in hardware standby mode.

15.2.2 D/A Control Register (DACR)

Bit	:	7	6	5	4	3	2	1	0
		DAOE1	DAOE0	DAE	—	—	—	—	—
Initial value:		0	0	0	1	1	1	1	1
R/W	:	R/W	R/W	R/W	—	—	—	—	—

DACR is an 8-bit readable/writable register that controls the operation of the D/A converter.

DACR is initialized to H'1F by a reset and in hardware standby mode.

Bit 7—D/A Output Enable 1 (DAOE1): Controls D/A conversion and analog output for channel 1.

Bit 7

DAOE1	Description
0	Analog output DA1 is disabled (Initial value)
1	Channel 1 D/A conversion is enabled; analog output DA1 is enabled

Bit 6—D/A Output Enable 0 (DAOE0): Controls D/A conversion and analog output for channel 0.

Bit 6

DAOE0	Description
0	Analog output DA0 is disabled (Initial value)
1	Channel 0 D/A conversion is enabled; analog output DA0 is enabled

Bit 5—D/A Enable (DAE): The DAOE0 and DAOE1 bits both control D/A conversion. When the DAE bit is cleared to 0, the channel 0 and 1 D/A conversions are controlled independently. When the DAE bit is set to 1, the channel 0 and 1 D/A conversions are controlled together.

Output of resultant conversions is always controlled independently by the DAOE0 and DAOE1 bits.

Bit 7	Bit 6	Bit 5	Description
DAOE1	DAOE0	DAE	
0	0	*	Channel 0 and 1 D/A conversions disabled
		1	Channel 0 D/A conversion enabled Channel 1 D/A conversion disabled
		1	Channel 0 and 1 D/A conversions enabled
1	0	0	Channel 0 D/A conversion disabled Channel 1 D/A conversion enabled
		1	Channel 0 and 1 D/A conversions enabled
		1	Channel 0 and 1 D/A conversions enabled

*: Don't care

If the H8S/2355 Series enters software standby mode when D/A conversion is enabled, the D/A output is held and the analog power current is the same as during D/A conversion. When it is necessary to reduce the analog power current in software standby mode, clear both the DAOE0 and DAOE1 bits to 0 to disable D/A output.

Bits 4 to 0—Reserved: Read-only bits, always read as 1.

15.2.3 Module Stop Control Register (MSTPCR)

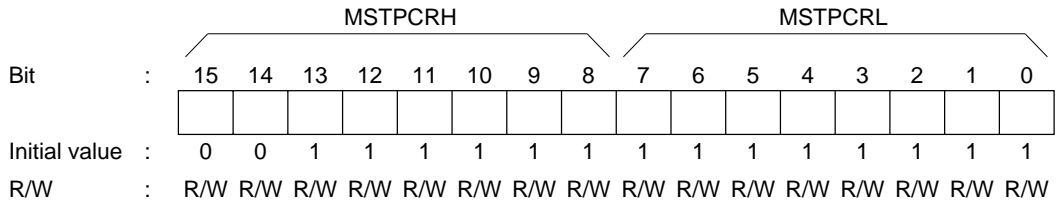

MSTPCR is a 16-bit readable/writable register that performs module stop mode control.

In the H8S/2355 and H8S/2353, when the MSTP10 bit in MSTPCR is set to 1, D/A converter operation stops at the end of the bus cycle and a transition is made to module stop mode. Registers cannot be read or written to in module stop mode. For details, see section 19.5, Module Stop Mode.

MSTPCR is initialized to H'3FFF by a reset and in hardware standby mode. It is not initialized in software standby mode.

Bit 10—Module Stop (MSTP10): Specifies the D/A converter module stop mode.

Bit 10

MSTP10	Description
0	D/A converter module stop mode cleared
1	D/A converter module stop mode set (Initial value)

15.3 Operation

The D/A converter includes D/A conversion circuits for two channels, each of which can operate independently.

D/A conversion is performed continuously while enabled by DACR. If either DADR0 or DADR1 is written to, the new data is immediately converted. The conversion result is output by setting the corresponding DAOE0 or DAOE1 bit to 1.

The operation example described in this section concerns D/A conversion on channel 0. Figure 15-2 shows the timing of this operation.

[1] Write the conversion data to DADR0.

[2] Set the DAOE0 bit in DACR to 1. D/A conversion is started and the DA0 pin becomes an output pin. The conversion result is output after the conversion time has elapsed. The output value is expressed by the following formula:

$$\frac{\text{DADR contents}}{256} \times V_{\text{ref}}$$

The conversion results are output continuously until DADR0 is written to again or the DAOE0 bit is cleared to 0.

[3] If DADR0 is written to again, the new data is immediately converted. The new conversion result is output after the conversion time has elapsed.

[4] If the DAOE0 bit is cleared to 0, the DA0 pin becomes an input pin.

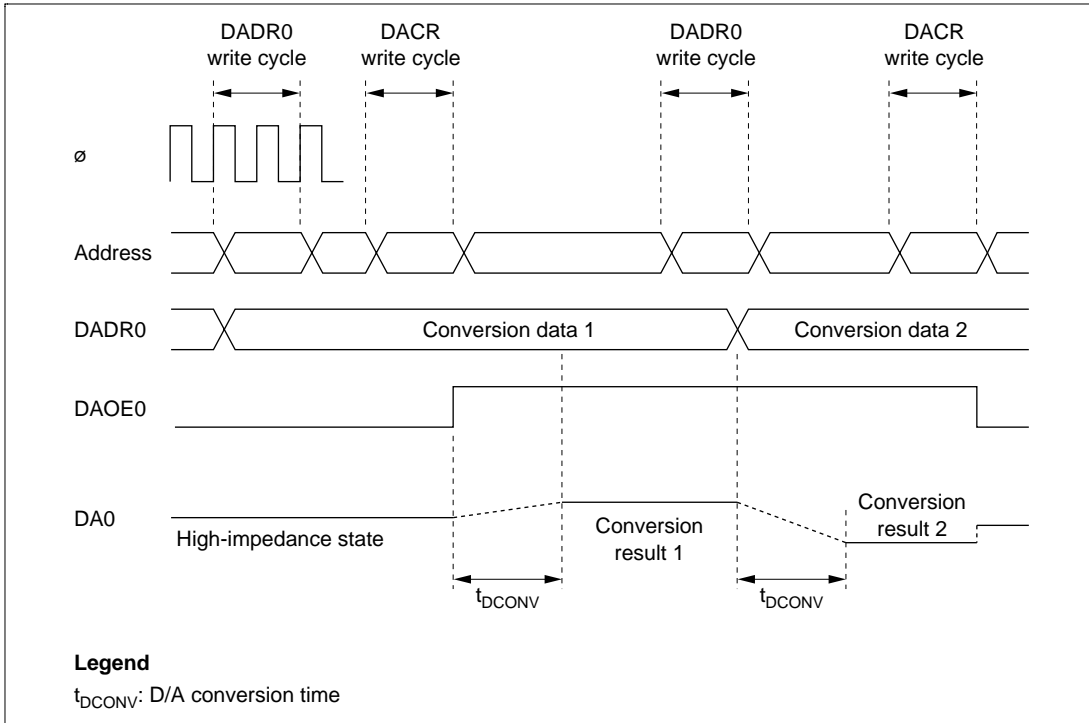

Figure 15-2 Example of D/A Converter Operation

Section 16 RAM

16.1 Overview

The H8S/2355 and H8S/2393 have 4 kbytes of on-chip high-speed static RAM, and the H8S/2353 has 2 kbytes. The RAM is connected to the CPU by a 16-bit data bus, enabling one-state access by the CPU to both byte data and word data. This makes it possible to perform fast word data transfer.

The on-chip RAM can be enabled or disabled by means of the RAM enable bit (RAME) in the system control register (SYSCR).

16.1.1 Block Diagram

Figure 16-1 shows a block diagram of the on-chip RAM.

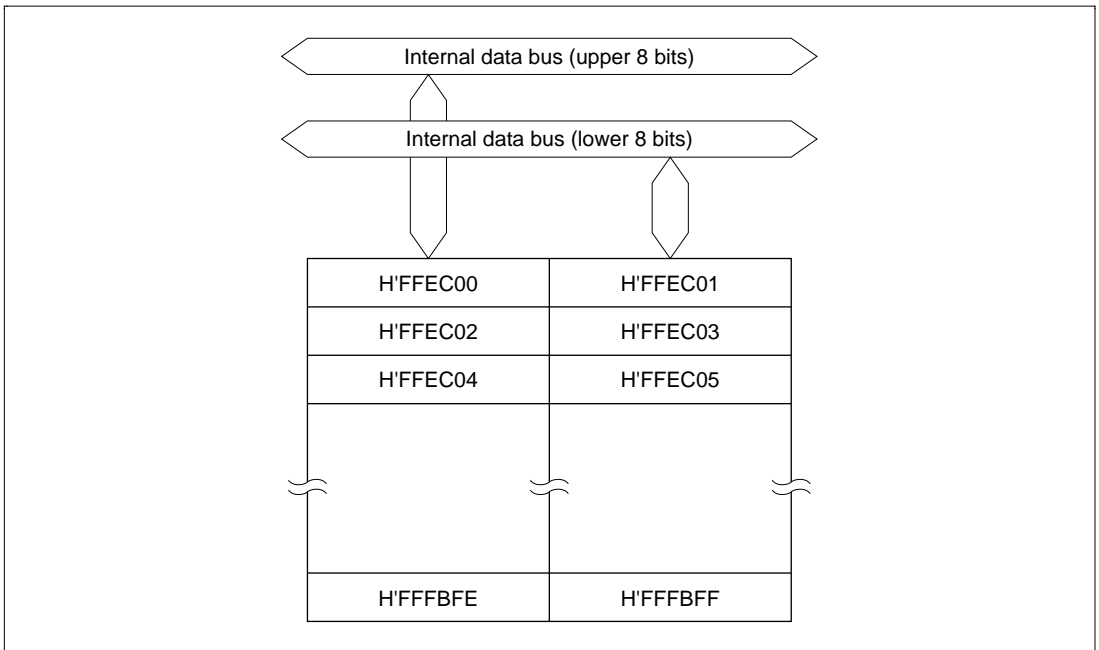

Figure 16-1 Block Diagram of RAM (H8S/2355)

16.1.2 Register Configuration

The on-chip RAM is controlled by SYSCR. Table 16-1 shows the address and initial value of SYSCR.

Table 16-1 RAM Register

Name	Abbreviation	R/W	Initial Value	Address*
System control register	SYSCR	R/W	H'01	H'FF39

Note: * Lower 16 bits of the address.

16.2 Register Descriptions

16.2.1 System Control Register (SYSCR)

Bit	:	7	6	5	4	3	2	1	0
		—	—	INTM1	INTM0	NMIEG	—	—	RAME
Initial value :		0	0	0	0	0	0	0	1
R/W	:	R/W	—	R/W	R/W	R/W	—	R/W	R/W

The on-chip RAM is enabled or disabled by the RAME bit in SYSCR. For details of other bits in SYSCR, see section 3.2.2, System Control Register (SYSCR).

Bit 0—RAM Enable (RAME): Enables or disables the on-chip RAM. The RAME bit is initialized when the reset state is released. It is not initialized in software standby mode.

Bit 0

RAME	Description
0	On-chip RAM is disabled
1	On-chip RAM is enabled (Initial value)

16.3 Operation

When the RAME bit is set to 1, accesses to addresses H'FFEC00 to H'FFFBFF are directed to the on-chip RAM. When the RAME bit is cleared to 0, the off-chip address space is accessed.

Since the on-chip RAM is connected to the CPU by an internal 16-bit data bus, it can be written to and read in byte or word units. Each type of access can be performed in one state.

Even addresses use the upper 8 bits, and odd addresses use the lower 8 bits. Word data must start at an even address.

16.4 Usage Note

DTC register information can be located in addresses H'FFF800 to H'FFFBFF. When the DTC is used, the RAME bit must not be cleared to 0.

Section 17 ROM

17.1 Overview

The H8S/2355 has 128 kbytes of on-chip ROM (PROM or mask ROM). The H8S/2353 has 64 kbytes of on-chip mask ROM, and the H8S/2393 has 32 kbytes of on-chip mask ROM. The ROM is connected to the H8S/2000 CPU by a 16-bit data bus. The CPU accesses both byte data and word data in one state, making possible rapid instruction fetches and high-speed processing.

The on-chip ROM is enabled or disabled by setting the mode pins (MD_2 , MD_1 , and MD_0) and bit EAE in BCRL.

The PROM version of the H8S/2355 Series can be programmed with a general-purpose PROM programmer, by setting PROM mode.

17.1.1 Block Diagram

Figure 17-1 shows a block diagram of the on-chip ROM.

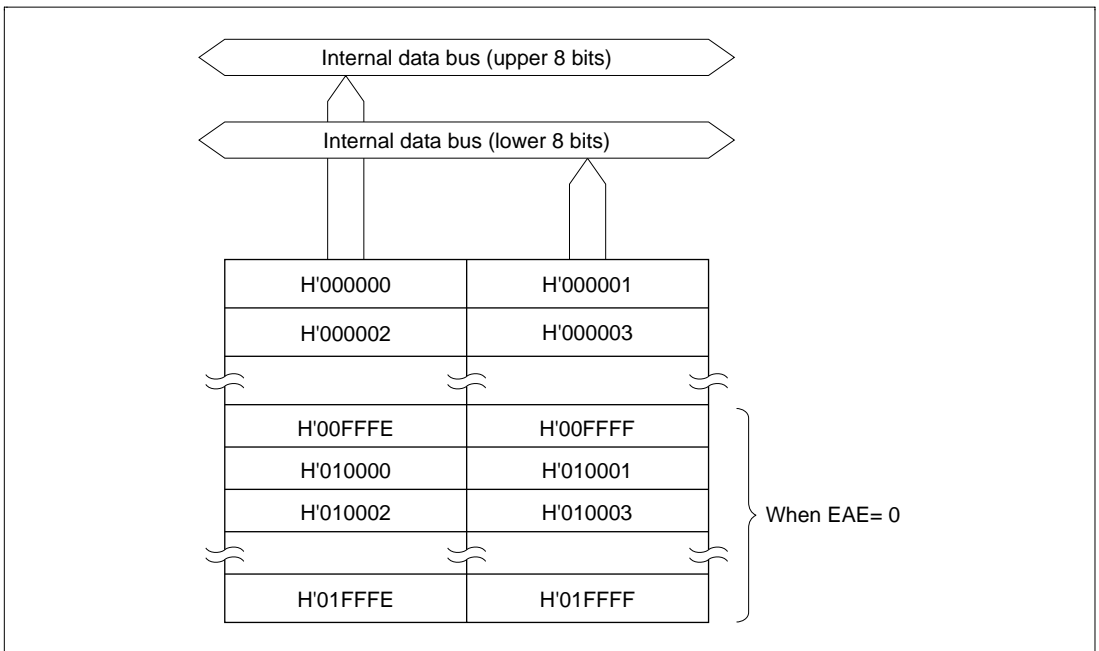

Figure 17-1 Block Diagram of ROM (H8S/2355)

17.1.2 Register Configuration

The H8S/2355's on-chip ROM is controlled by BCRL. The register configuration is shown in table 17-1.

Table 17-1 ROM Register

Name	Abbreviation	R/W	Initial Value		Address*
			Power-On Reset	Manual Reset	
Bus control register L	BCRL	R/W	H'3C	Retained	H'FED5

Note: * Lower 16 bits of the address.

17.2 Register Descriptions

17.2.1 Bus Control Register L (BCRL)

Bit	:	7	6	5	4	3	2	1	0
		BRLE	—	EAE	—	—	—	—	WAITE
Initial value	:	0	0	1	1	1	1	0	0
R/W	:	R/W	R/W	R/W	R/W	R/W	R/W	R/W	R/W

Enabling or disabling of part of the H8S/2355's on-chip ROM area can be selected by means of the EAE bit in BCRL. For details of the other bits in BCRL, see 6.2.5, Bus Control Register L.

Bit 5—External Address Enable (EAE): Selects whether addresses H'010000 to H'01FFFF are to be internal addresses or external addresses.

This setting is invalid in normal mode.

Bit 5

EAE	Description
0	Addresses H'010000 to H'01FFFF are in on-chip ROM (in the H8S/2355) or a reserved area* (in the H8S/2353).
1	Addresses H'010000 to H'01FFFF are external addresses (external expansion mode) or a reserved area* (single-chip mode). (Initial value)

Note: * Reserved areas should not be accessed.

17.3 Operation

The on-chip ROM is connected to the CPU by a 16-bit data bus, and both byte and word data can be accessed in one state. Even addresses are connected to the upper 8 bits, and odd addresses to the lower 8 bits. Word data must start at an even address.

The on-chip ROM is enabled and disabled by setting the mode pins (MD₂, MD₁, and MD₀) and bit EAE in BCRL. These settings are shown in table 17-2.

In normal mode, a maximum of 56 kbytes of ROM can be used.

Table 17-2 Operating Modes and ROM Area

Operating Mode	Mode Pin			BCRL	
	MD ₂	MD ₁	MD ₀	EAE	On-Chip ROM
Mode 1 Normal expanded mode with on-chip ROM disabled	0	0	1	—	Disabled
Mode 2 Normal expanded mode with on-chip ROM enabled		1	0	—	Enabled (56 kbytes)
Mode 3 Normal single-chip mode			1		
Mode 4 Advanced expanded mode with on-chip ROM disabled	1	0	0	—	Disabled
Mode 5 Advanced expanded mode with on-chip ROM disabled			1		
Mode 6 Advanced expanded mode with on-chip ROM enabled		1	0	0	Enabled*
				1	Enabled (64 kbytes)
Mode 7 Advanced single-chip mode			1	0	Enabled*
				1	Enabled (64 kbytes)

Note: * 128 kbytes in the H8S/2355, 64 kbytes in the H8S/2353, 32 kbytes in the H8S/2393

In H8/2355 modes 6 and 7, the on-chip ROM available after a power-on reset is the 64-kbyte area comprising addresses H'000000 to H'00FFFF.

17.4 PROM Mode

17.4.1 PROM Mode Setting

The PROM version of the H8S/2355 Series suspends its microcontroller functions when placed in PROM mode, enabling the on-chip PROM to be programmed. This programming can be done with a PROM programmer set up in the same way as for the HN27C101 EPROM ($V_{PP} = 12.5\text{ V}$). Use of a socket adapter to convert from 120 or 128 pins to 32 pins enables programming with a commercial PROM programmer.

Note that the PROM programmer should not be set to page mode as the H8S/2355 Series does not support page programming.

Table 17-3 shows how PROM mode is selected.

Table 17-3 Selecting PROM Mode

Pin Names	Setting
MD_2, MD_1, MD_0	Low
\overline{STBY}	
PA_2, PA_1	High

17.4.2 Socket Adapter and Memory Map

Programs can be written and verified by attaching a socket adapter to convert from 120 or 128 pins to 32 pins to the PROM programmer. Table 17-4 gives ordering information for the socket adapter, and figure 17-2 shows the wiring of the socket adapter. Figure 17-3 shows the memory map in PROM mode.

H8S/2355 Series

EPROM socket

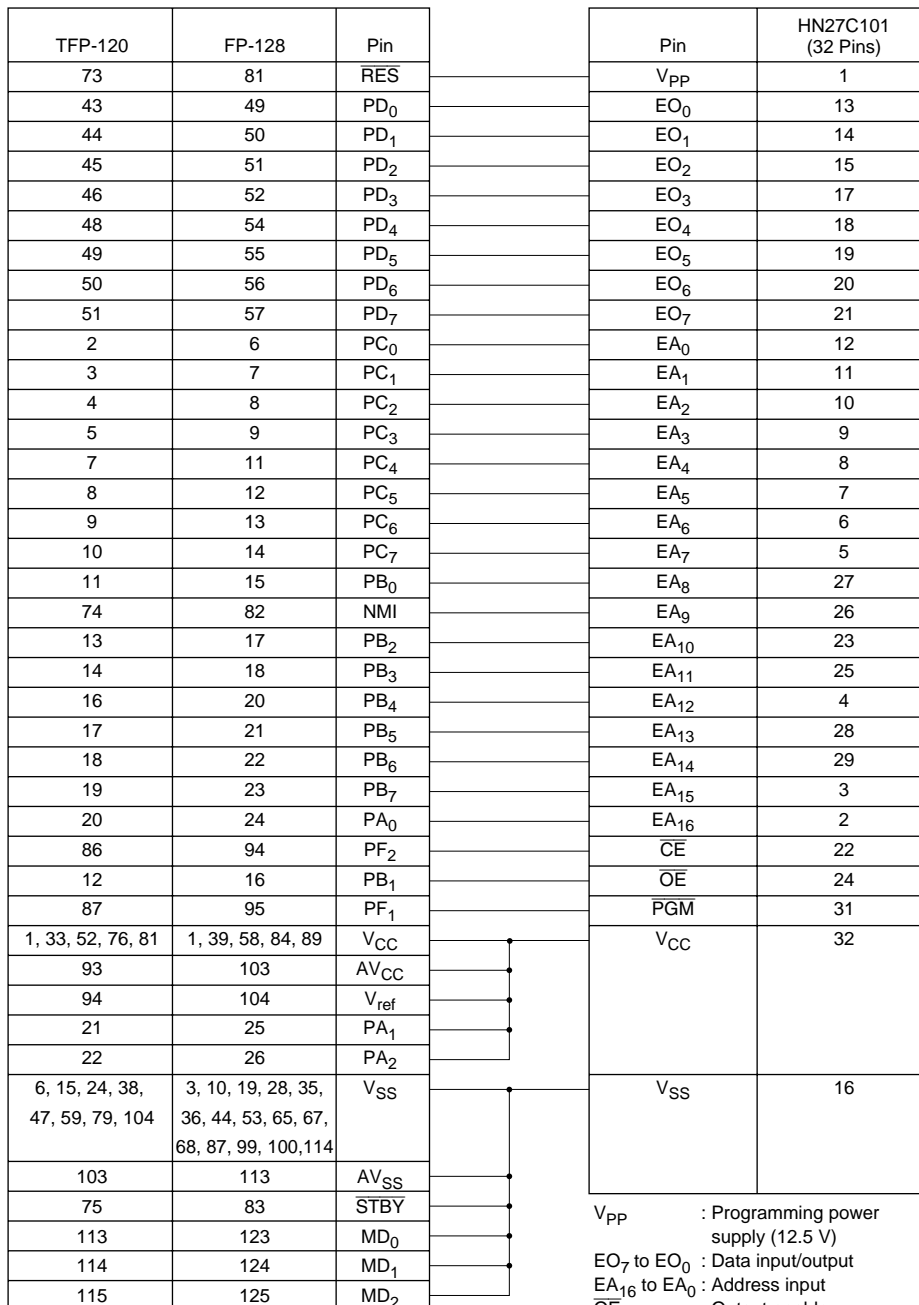

Note: Pins not shown in this figure should be left open.

Figure 17-2 Wiring of 120-Pin/32-Pin Socket Adapter

Table 17-4 Socket Adapter

Microcontroller	Package	Socket Adapter
H8S/2355	120 pin TQFP (TFP-120)	HS2655ESNS1H
	128 pin QFP (FP-128)	HS2655ESHS1H

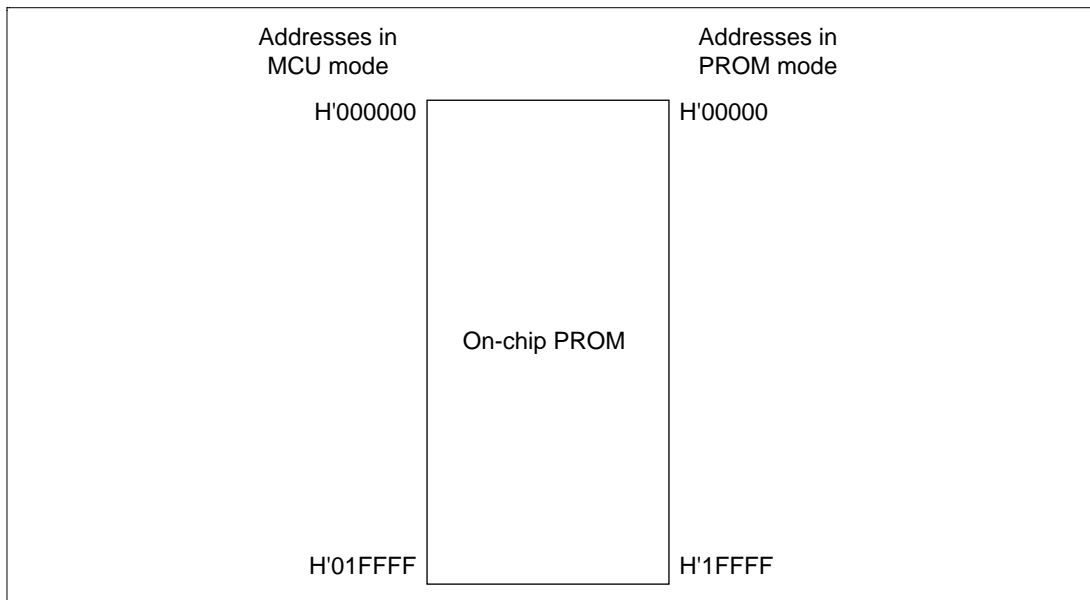

Figure 17-3 Memory Map in PROM Mode

17.5 Programming

17.5.1 Overview

Table 17-5 shows how to select the program, verify, and program-inhibit modes in PROM mode.

Table 17-5 Mode Selection in PROM Mode

Mode	Pins						
	$\overline{\text{CE}}$	$\overline{\text{OE}}$	$\overline{\text{PGM}}$	V_{PP}	V_{CC}	EO_7 to EO_0	EA_{16} to EA_0
Program	L	H	L	V_{PP}	V_{CC}	Data input	Address input
Verify	L	L	H	V_{PP}	V_{CC}	Data output	Address input
Program-inhibit	L	L	L	V_{PP}	V_{CC}	High impedance	Address input
	L	H	H				
	H	L	L				
	H	H	H				

Legend

L : Low voltage level

H : High voltage level

V_{PP} : V_{PP} voltage level

V_{CC} : V_{CC} voltage level

Programming and verification should be carried out using the same specifications as for the standard HN27C101 EPROM.

However, do not set the PROM programmer to page mode does not support page programming. A PROM programmer that only supports page programming cannot be used. When choosing a PROM programmer, check that it supports high-speed programming in byte units. Always set addresses within the range H'00000 to H'0FFFF.

17.5.2 Programming and Verification

An efficient, high-speed programming procedure can be used to program and verify PROM data. This procedure writes data quickly without subjecting the chip to voltage stress or sacrificing data reliability. It leaves the data H'FF in unused addresses. Figure 17-4 shows the basic high-speed programming flowchart. Tables 17-6 and 17-7 list the electrical characteristics of the chip during programming. Figure 17-5 shows a timing chart.

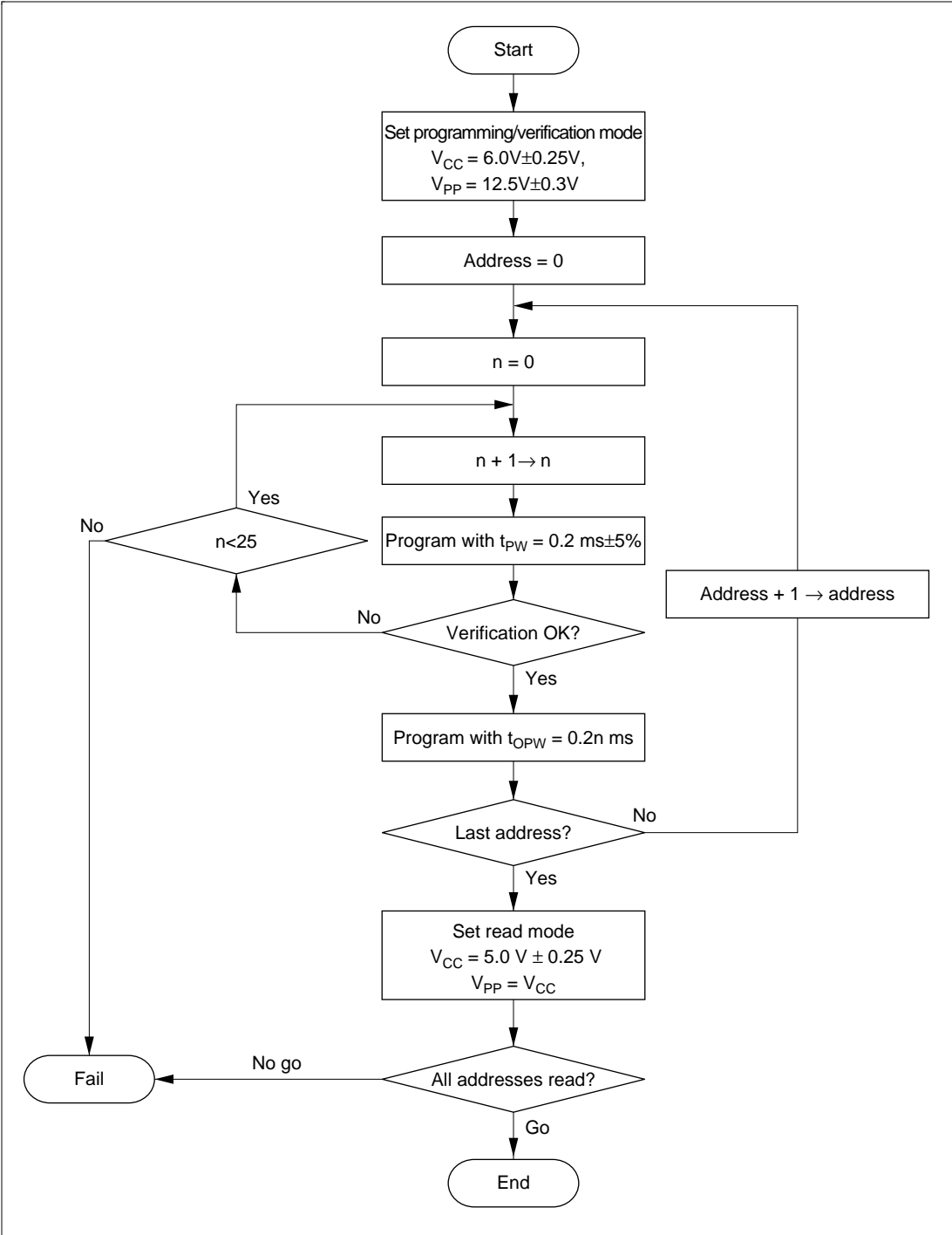

Figure 17-4 High-Speed Programming Flowchart

Table 17-6 DC Characteristics in PROM Mode(When $V_{CC} = 6.0 \text{ V} \pm 0.25 \text{ V}$, $V_{PP} = 12.5 \text{ V} \pm 0.3 \text{ V}$, $V_{SS} = 0 \text{ V}$, $T_a = 25^\circ\text{C} \pm 5^\circ\text{C}$)

Item		Symbol	Min	Typ	Max	Unit	Test Conditions
Input high voltage	\overline{EO}_7 to \overline{EO}_0 , \overline{EA}_{16} to \overline{EA}_0 , \overline{OE} , \overline{CE} , \overline{PGM}	V_{IH}	2.4	—	$V_{CC} + 0.3$	V	
Input low voltage	\overline{EO}_7 to \overline{EO}_0 , \overline{EA}_{16} to \overline{EA}_0 , \overline{OE} , \overline{CE} , \overline{PGM}	V_{IL}	-0.3	—	0.8	V	
Output high voltage	\overline{EO}_7 to \overline{EO}_0	V_{OH}	2.4	—	—	V	$I_{OH} = -200 \mu\text{A}$
Output low voltage	\overline{EO}_7 to \overline{EO}_0	V_{OL}	—	—	0.45	V	$I_{OL} = 1.6 \text{ mA}$
Input leakage current	\overline{EO}_7 to \overline{EO}_0 , \overline{EA}_{16} to \overline{EA}_0 , \overline{OE} , \overline{CE} , \overline{PGM}	$ I_{LI} $	—	—	2	μA	$V_{in} = 5.25 \text{ V}/0.5 \text{ V}$
V_{CC} current		I_{CC}	—	—	40	mA	
V_{PP} current		I_{PP}	—	—	40	mA	

Table 17-7 AC Characteristics in PROM Mode(When $V_{CC} = 6.0 \text{ V} \pm 0.25 \text{ V}$, $V_{PP} = 12.5 \text{ V} \pm 0.3 \text{ V}$, $T_a = 25^\circ\text{C} \pm 5^\circ\text{C}$)

Item	Symbol	Min	Typ	Max	Unit	Test Conditions
Address setup time	t_{AS}	2	—	—	μs	Figure 17-5* ¹
$\overline{\text{OE}}$ setup time	t_{OES}	2	—	—	μs	
Data setup time	t_{DS}	2	—	—	μs	
Address hold time	t_{AH}	0	—	—	μs	
Data hold time	t_{DH}	2	—	—	μs	
Data output disable time	t_{DF} * ²	—	—	130	ns	
V_{PP} setup time	t_{VPS}	2	—	—	μs	
Programming pulse width	t_{PW}	0.19	0.20	0.21	ms	
$\overline{\text{PGM}}$ pulse width for overwrite programming	t_{OPW} * ³	0.19	—	5.25	ms	
V_{CC} setup time	t_{VCS}	2	—	—	μs	
$\overline{\text{CE}}$ setup time	t_{CES}	2	—	—	μs	
Data output delay time	t_{OE}	0	—	150	ns	

Notes: 1. Input pulse level: 0.8 V to 2.2 V

Input rise time and fall time $\leq 20 \text{ ns}$

Timing reference levels: Input: 1.0 V, 2.0 V

Output: 0.8 V, 2.0 V

2. t_{DF} is defined to be when output has reached the open state, and the output level can no longer be referenced.
3. t_{OPW} is defined by the value shown in the flowchart.

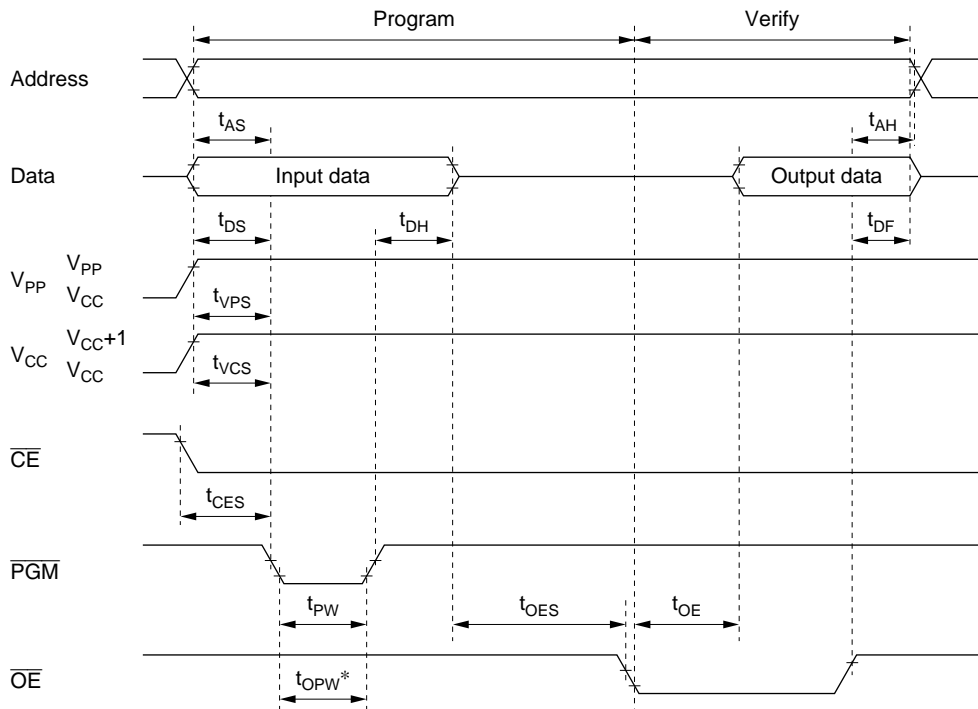

Note: * t_{OPW} is defined by the value shown in the flowchart.

Figure 17-5 PROM Programming/Verification Timing

17.5.3 Programming Precautions

- Program using the specified voltages and timing.
The programming voltage (V_{pp}) in PROM mode is 12.5 V.
If the PROM programmer is set to Hitachi HN27C101 specifications, V_{pp} will be 12.5 V. Applied voltages in excess of the specified values can permanently destroy the MCU. Be particularly careful about the PROM programmer's overshoot characteristics.
- Before programming, check that the MCU is correctly mounted in the PROM programmer. Overcurrent damage to the MCU can result if the index marks on the PROM programmer, socket adapter, and MCU are not correctly aligned.
- Do not touch the socket adapter or MCU while programming. Touching either of these can cause contact faults and programming errors.
- The MCU cannot be programmed in page programming mode. Select the programming mode carefully.
- The size of the H8S/2355 PROM is 128 kbytes. Always set addresses within the range H'00000 to H'0FFFF. During programming, write H'FF to unused addresses to avoid verification errors.

17.5.4 Reliability of Programmed Data

An effective way to assure the data retention characteristics of the programmed chips is to bake them at 150°C, then screen them for data errors. This procedure quickly eliminates chips with PROM memory cells prone to early failure.

Figure 17-6 shows the recommended screening procedure.

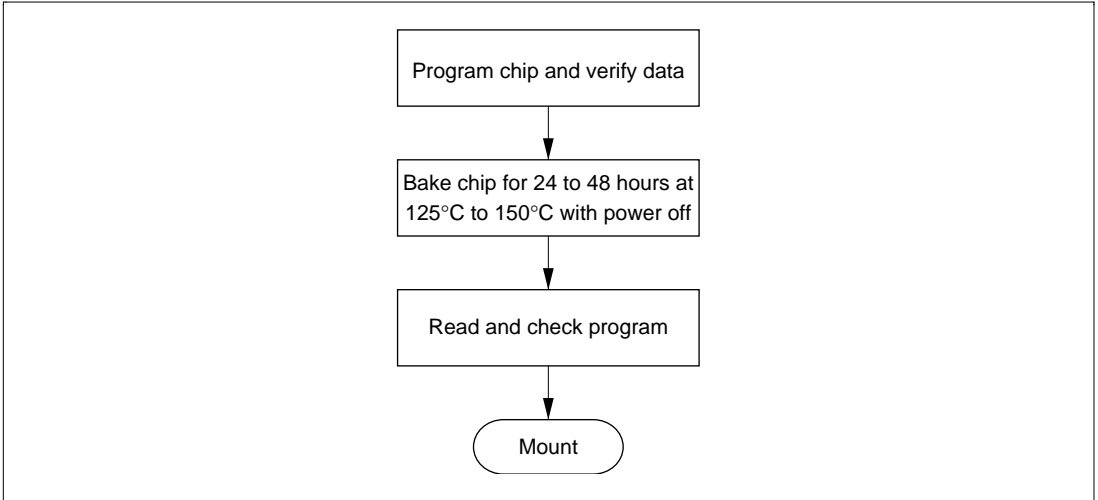

Figure 17-6 Recommended Screening Procedure

If a series of programming errors occurs while the same PROM programmer is being used, stop programming and check the PROM programmer and socket adapter for defects.

Please inform Hitachi of any abnormal conditions noted during or after programming or in screening of program data after high-temperature baking.

Section 18 Clock Pulse Generator

18.1 Overview

The H8S/2355 Series has a built-in clock pulse generator (CPG) that generates the system clock (ϕ), the bus master clock, and internal clocks.

The clock pulse generator consists of an oscillator circuit, a duty adjustment circuit, a medium-speed clock divider, and a bus master clock selection circuit.

18.1.1 Block Diagram

Figure 18-1 shows a block diagram of the clock pulse generator.

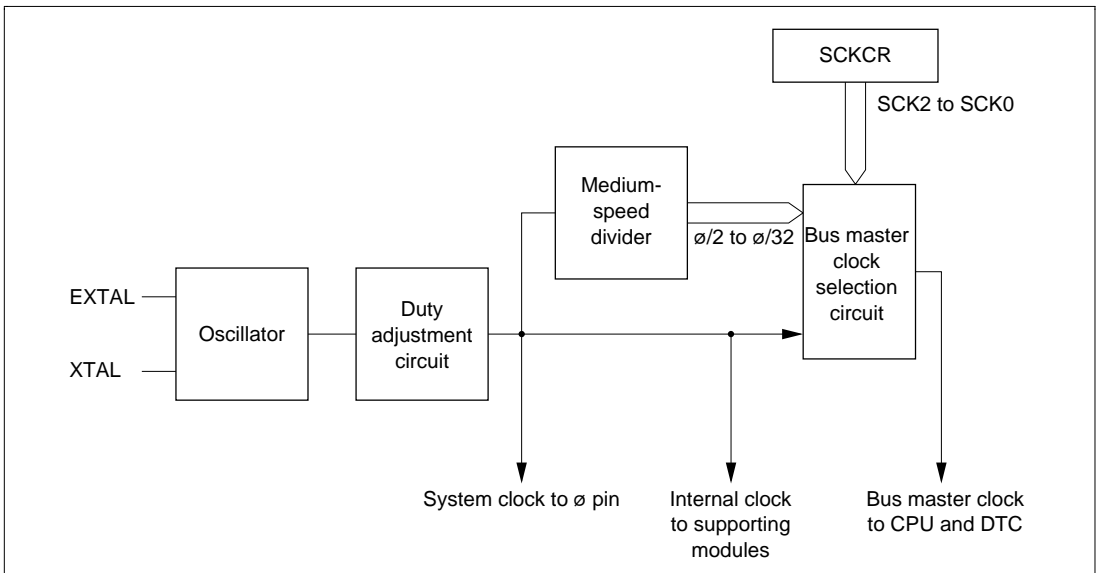

Figure 18-1 Block Diagram of Clock Pulse Generator

18.1.2 Register Configuration

The clock pulse generator is controlled by SCKCR. Table 18-1 shows the register configuration.

Table 18-1 Clock Pulse Generator Register

Name	Abbreviation	R/W	Initial Value	Address*
System clock control register	SCKCR	R/W	H'00	H'FF3A

Note:* Lower 16 bits of the address.

18.2 Register Descriptions

18.2.1 System Clock Control Register (SCKCR)

Bit	:	7	6	5	4	3	2	1	0
		PSTOP	—	—	—	—	SCK2	SCK1	SCK0
Initial value:		0	0	0	0	0	0	0	0
R/W	:	R/W	R/W	—	—	—	R/W	R/W	R/W

SCKCR is an 8-bit readable/writable register that performs ϕ clock output control and medium-speed mode control.

SCKCR is initialized to H'00 by a reset and in hardware standby mode. It is not initialized in software standby mode.

Bit 7— ϕ Clock Output Disable (PSTOP): Controls ϕ output.

Description

Bit 7	Description			
PSTOP	Normal Operation	Sleep Mode	Software Standby Mode	Hardware Standby Mode
0	ϕ output (initial value)	ϕ output	Fixed high	High impedance
1	Fixed high	Fixed high	Fixed high	High impedance

Bit 6—Reserved: This bit can be read or written to, but only 0 should be written.

Bits 5 to 3—Reserved: Read-only bits, always read as 0.

Bits 2 to 0—System Clock Select 2 to 0 (SCK2 to SCK0): These bits select the clock for the bus master.

Bit 2	Bit 1	Bit 0	Description
SCK2	SCK1	SCK0	
0	0	0	Bus master is in high-speed mode (Initial value)
		1	Medium-speed clock is $\phi/2$
	1	0	Medium-speed clock is $\phi/4$
		1	Medium-speed clock is $\phi/8$
1	0	0	Medium-speed clock is $\phi/16$
		1	Medium-speed clock is $\phi/32$
	1	—	—

18.3 Oscillator

Clock pulses can be supplied by connecting a crystal resonator, or by input of an external clock.

18.3.1 Connecting a Crystal Resonator

Circuit Configuration: A crystal resonator can be connected as shown in the example in figure 18-2. Select the damping resistance R_d according to table 18-2. An AT-cut parallel-resonance crystal should be used.

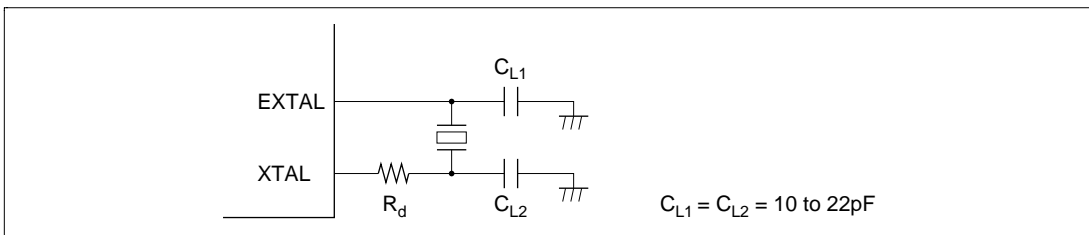

Figure 18-2 Connection of Crystal Resonator (Example)

Table 18-2 Damping Resistance Value

Frequency (MHz)	2	4	8	12	16	20
R_d (Ω)	1k	500	200	0	0	0

Crystal Resonator: Figure 18-3 shows the equivalent circuit of the crystal resonator. Use a crystal resonator that has the characteristics shown in table 18-3 and the same resonance frequency as the system clock (ϕ).

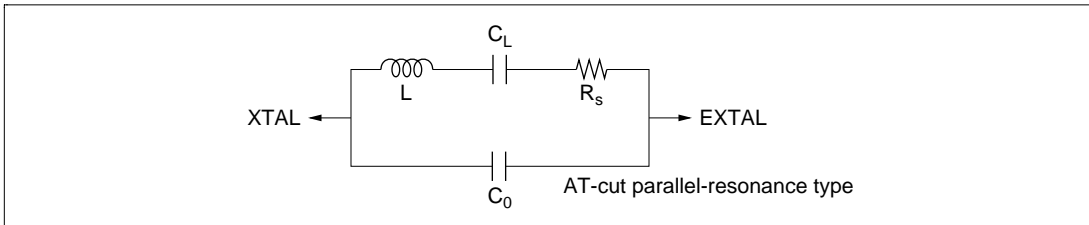

Figure 18-3 Crystal Resonator Equivalent Circuit

Table 18-3 Crystal Resonator Parameters

Frequency (MHz)	2	4	8	12	16	20
R_s max (Ω)	500	120	80	60	50	40
C_0 max (pF)	7	7	7	7	7	7

Note on Board Design: When a crystal resonator is connected, the following points should be noted:

Other signal lines should be routed away from the oscillator circuit to prevent induction from interfering with correct oscillation. See figure 18-4.

When designing the board, place the crystal resonator and its load capacitors as close as possible to the XTAL and EXTAL pins.

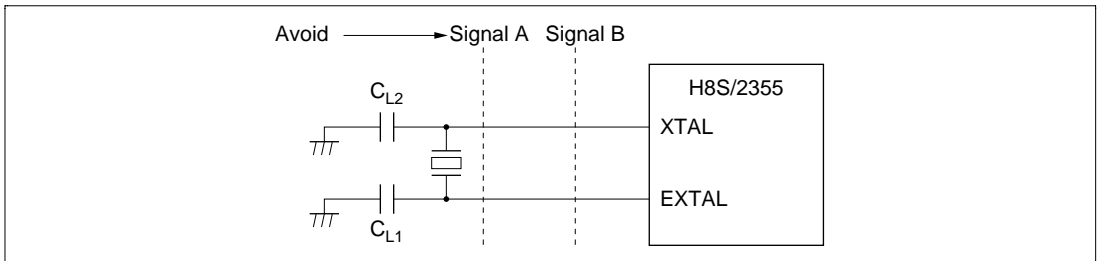

Figure 18-4 Example of Incorrect Board Design

18.3.2 External Clock Input

Circuit Configuration: An external clock signal can be input as shown in the examples in figure 18-5. If the XTAL pin is left open, make sure that stray capacitance is no more than 10 pF.

In example (b), make sure that the external clock is held high in standby mode.

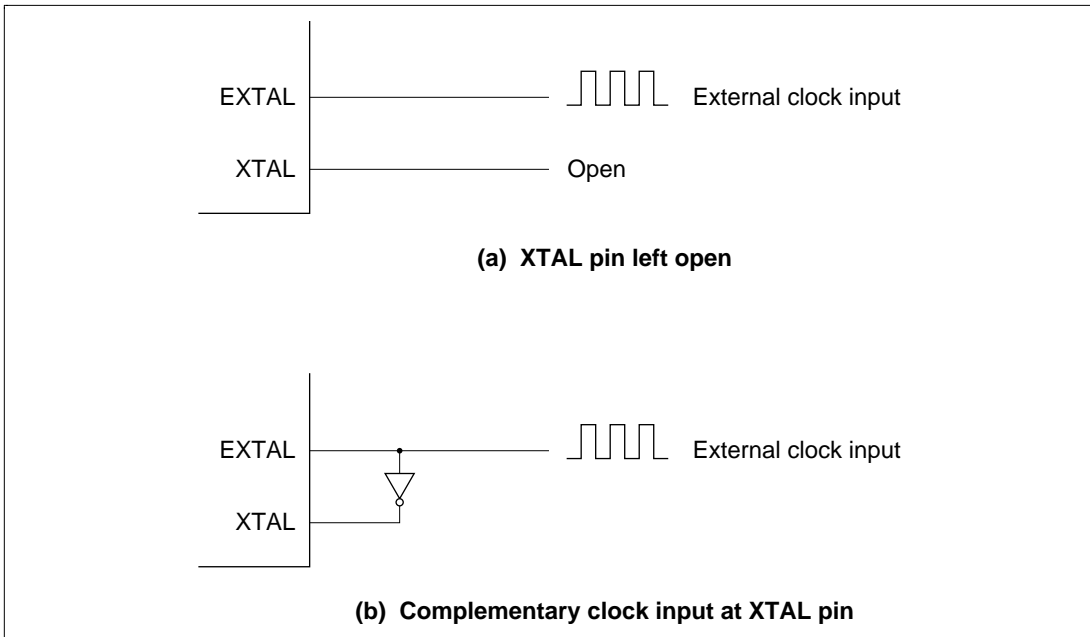

Figure 18-5 External Clock Input (Examples)

External Clock: The external clock signal should have the same frequency as the system clock (ϕ).

Table 18-4 and figure 18-6 show the input conditions for the external clock.

Table 18-4 External Clock Input Conditions

Item	Symbol	$V_{CC} = 2.7\text{ V}$ to 5.5 V		$V_{CC} = 5.0\text{ V} \pm$ 10%		Unit	Test Conditions	
		Min	Max	Min	Max			
External clock input low pulse width	t_{EXL}	40	—	20	—	ns	Figure 18-6	
External clock input high pulse width	t_{EXH}	40	—	20	—	ns		
External clock rise time	t_{EXr}	—	10	—	5	ns		
External clock fall time	t_{EXf}	—	10	—	5	ns		
Clock low pulse width level	t_{CL}	0.4	0.6	0.4	0.6	t_{cyc}	$\emptyset \geq 5\text{ MHz}$	Figure 20-4
		80	—	80	—	ns	$\emptyset < 5\text{ MHz}$	
Clock high pulse width level	t_{CH}	0.4	0.6	0.4	0.6	t_{cyc}	$\emptyset \geq 5\text{ MHz}$	
		80	—	80	—	ns	$\emptyset < 5\text{ MHz}$	

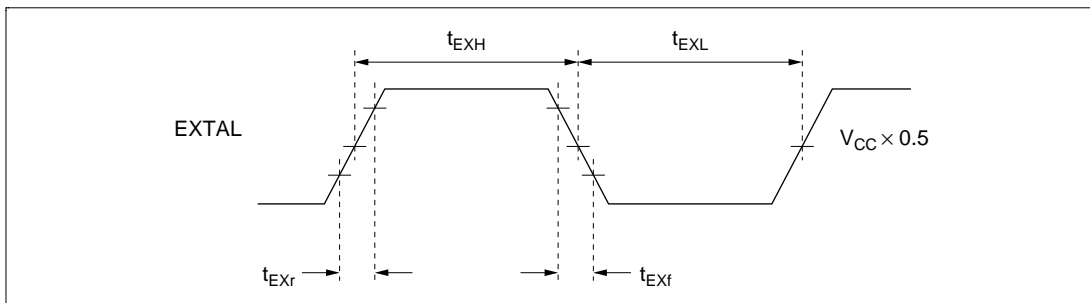

Figure 18-6 External Clock Input Timing

18.4 Duty Adjustment Circuit

When the oscillator frequency is 5 MHz or higher, the duty adjustment circuit adjusts the duty cycle of the clock signal from the oscillator to generate the system clock (ϕ).

18.5 Medium-Speed Clock Divider

The medium-speed clock divider divides the system clock to generate $\phi/2$, $\phi/4$, $\phi/8$, $\phi/16$, and $\phi/32$.

18.6 Bus Master Clock Selection Circuit

The bus master clock selection circuit selects the system clock (ϕ) or one of the medium-speed clocks ($\phi/2$, $\phi/4$, or $\phi/8$, $\phi/16$, and $\phi/32$) to be supplied to the bus master, according to the settings of the SCK2 to SCK0 bits in SCKCR.

Section 19 Power-Down Modes

19.1 Overview

In addition to the normal program execution state, the H8S/2355 Series has five power-down modes in which operation of the CPU and oscillator is halted and power dissipation is reduced. Low-power operation can be achieved by individually controlling the CPU, on-chip supporting modules, and so on.

The H8S/2355 Series operating modes are as follows:

- (1) High-speed mode
- (2) Medium-speed mode
- (3) Sleep mode
- (4) Module stop mode
- (5) Software standby mode
- (6) Hardware standby mode

Of these, (2) to (6) are power-down modes. Sleep mode is a CPU mode, medium-speed mode is a CPU and bus master mode, and module stop mode is an on-chip supporting module mode (including bus masters other than the CPU). A combination of these modes can be set.

After a reset, the H8S/2355 Series is in high-speed mode.

Table 19-1 shows the conditions for transition to the various modes, the status of the CPU, on-chip supporting modules, etc., and the method of clearing each mode.

Table 19-1 Operating Modes

Operating Mode	Transition Condition	Clearing Condition	Oscillator	CPU		Modules		I/O Ports
				Registers	Registers	Registers	Registers	
High speed mode	Control register		Functions	High speed	Functions	High speed	Functions	High speed
Medium-speed mode	Control register		Functions	Medium speed	Functions	High/medium speed * ¹	Functions	High speed
Sleep mode	Instruction	Interrupt	Functions	Halted	Retained	High speed	Functions	High speed
Module stop mode	Control register		Functions	High/medium speed	Functions	Halted	Retained/reset * ²	Retained
Software standby mode	Instruction	External interrupt	Halted	Halted	Retained	Halted	Retained/reset * ²	Retained
Hardware standby mode	Pin		Halted	Halted	Undefined	Halted	Reset	High impedance

- Notes: 1. The bus master operates on the medium-speed clock, and other on-chip supporting modules on the high-speed clock.
2. The SCI and A/D converter are reset, and other on-chip supporting modules retain their state.

19.1.1 Register Configuration

Power-down modes are controlled by the SBYCR, SCKCR, and MSTPCR registers. Table 19-2 summarizes these registers.

Table 19-2 Power-Down Mode Registers

Name	Abbreviation	R/W	Initial Value	Address*
Standby control register	SBYCR	R/W	H'08	H'FF38
System clock control register	SCKCR	R/W	H'00	H'FF3A
Module stop control register H	MSTPCRH	R/W	H'3F	H'FF3C
Module stop control register L	MSTPCRL	R/W	H'FF	H'FF3D

Note: * Lower 16 bits of the address.

19.2 Register Descriptions

19.2.1 Standby Control Register (SBYCR)

Bit	:	7	6	5	4	3	2	1	0
		SSBY	STS2	STS1	STS0	OPE	—	—	—
Initial value	:	0	0	0	0	1	0	0	0
R/W	:	R/W	R/W	R/W	R/W	R/W	—	—	R/W

SBYCR is an 8-bit readable/writable register that performs software standby mode control.

SBYCR is initialized to H'08 by a reset and in hardware standby mode. It is not initialized in software standby mode.

Bit 7—Software Standby (SSBY): Specifies a transition to software standby mode. Remains set to 1 when software standby mode is released by an external interrupt, and a transition is made to normal operation. The SSBY bit should be cleared by writing 0 to it.

Bit 7

SSBY	Description
0	Transition to sleep mode after execution of SLEEP instruction (Initial value)
1	Transition to software standby mode after execution of SLEEP instruction

Bits 6 to 4—Standby Timer Select 2 to 0 (STS2 to STS0): These bits select the time the MCU waits for the clock to stabilize when software standby mode is cleared by an external interrupt. With crystal oscillation, refer to table 19-4 and make a selection according to the operating frequency so that the standby time is at least 8 ms (the oscillation stabilization time). With an external clock, any selection can be made.

Bit 6	Bit 5	Bit 4	Description
STS2	STS1	STS0	
0	0	0	Standby time = 8192 states (Initial value)
		1	Standby time = 16384 states
	1	0	Standby time = 32768 states
		1	Standby time = 65536 states
1	0	0	Standby time = 131072 states
		1	Standby time = 262144 states
	1	0	Reserved
		1	Standby time = 16 states

Bit 3—Output Port Enable (OPE): Specifies whether the output of the address bus and bus control signals ($\overline{CS0}$ to $\overline{CS7}$, \overline{AS} , \overline{RD} , \overline{HWR} , \overline{LWR}) is retained or set to the high-impedance state in software standby mode.

Bit 3

OPE	Description
0	In software standby mode, address bus and bus control signals are high-impedance
1	In software standby mode, address bus and bus control signals retain output state (Initial value)

Bits 2 and 1—Reserved: Read-only bits, always read as 0.

Bit 0—Reserved: This bit can be read or written to, but only 0 should be written.

19.2.2 System Clock Control Register (SCKCR)

Bit	:	7	6	5	4	3	2	1	0
		PSTOP	—	—	—	—	SCK2	SCK1	SCK0
Initial value	:	0	0	0	0	0	0	0	0
R/W	:	R/W	R/W	—	—	—	R/W	R/W	R/W

SCKCR is an 8-bit readable/writable register that performs ϕ clock output control and medium-speed mode control.

SCKCR is initialized to H'00 by a reset and in hardware standby mode. It is not initialized in software standby mode.

Bit 7— ϕ Clock Output Disable (PSTOP): Controls ϕ output.

Bit 7	Description			
	Normal Operating Mode	Sleep Mode	Software Standby Mode	Hardware Standby Mode
0	ϕ output (initial value)	ϕ output	Fixed high	High impedance
1	Fixed high	Fixed high	Fixed high	High impedance

Bits 6—Reserved: This bit can be read or written to, but only 0 should be written.

Bits 5 to 3—Reserved: Read-only bits, always read as 0.

Bits 2 to 0—System Clock Select (SCK2 to SCK0): These bits select the clock for the bus master.

Bit 2	Bit 1	Bit 0	Description
SCK2	SCK1	SCK0	
0	0	0	Bus master in high-speed mode (Initial value)
		1	Medium-speed clock is $\phi/2$
	1	0	Medium-speed clock is $\phi/4$
		1	Medium-speed clock is $\phi/8$
1	0	0	Medium-speed clock is $\phi/16$
		1	Medium-speed clock is $\phi/32$
	1	—	—

19.2.3 Module Stop Control Register (MSTPCR)

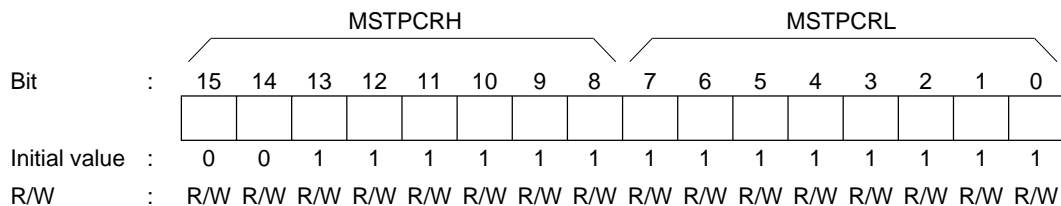

MSTPCR is a 16-bit readable/writable register that performs module stop mode control.

MSTPCR is initialized to H'3FFF by a reset and in hardware standby mode. It is not initialized in software standby mode.

Bits 15 to 0—Module Stop (MSTP 15 to MSTP 0): These bits specify module stop mode. See table 19-3 for the method of selecting on-chip supporting modules.

Bits 15 to 0

MSTP15 to MSTP0	Description
0	Module stop mode cleared
1	Module stop mode set

19.3 Medium-Speed Mode

When the SCK2 to SCK0 bits in SCKCR are set to 1, the operating mode changes to medium-speed mode as soon as the current bus cycle ends. In medium-speed mode, the CPU operates on the operating clock ($\phi/2$, $\phi/4$, $\phi/8$, $\phi/16$, or $\phi/32$) specified by the SCK2 to SCK0 bits. The bus masters other than the CPU (the DTC) also operate in medium-speed mode. On-chip supporting modules other than the bus masters always operate on the high-speed clock (ϕ).

In medium-speed mode, a bus access is executed in the specified number of states with respect to the bus master operating clock. For example, if $\phi/4$ is selected as the operating clock, on-chip memory is accessed in 4 states, and internal I/O registers in 8 states.

Medium-speed mode is cleared by clearing all of bits SCK2 to SCK0 to 0. A transition is made to high-speed mode and medium-speed mode is cleared at the end of the current bus cycle.

If a SLEEP instruction is executed when the SSBY bit in SBYCR is cleared to 0, a transition is made to sleep mode. When sleep mode is cleared by an interrupt, medium-speed mode is restored.

If a SLEEP instruction is executed when the SSBY bit in SBYCR is set to 1, a transition is made to software standby mode. When software standby mode is cleared by an external interrupt, medium-speed mode is restored.

When the $\overline{\text{RES}}$ pin is driven low, a transition is made to the reset state, and medium-speed mode is cleared. The same applies in the case of a reset caused by overflow of the watchdog timer.

When the $\overline{\text{STBY}}$ pin is driven low, a transition is made to hardware standby mode.

Figure 19-1 shows the timing for transition to and clearance of medium-speed mode.

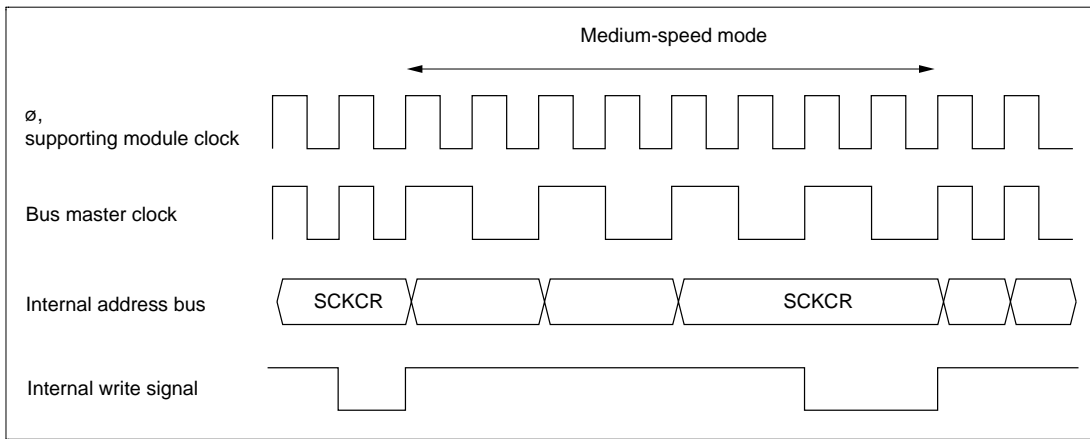

Figure 19-1 Medium-Speed Mode Transition and Clearance Timing

19.4 Sleep Mode

If a SLEEP instruction is executed when the SSBY bit in SBYCR is cleared to 0, the CPU enters sleep mode. In sleep mode, CPU operation stops but the contents of the CPU's internal registers are retained. Other supporting modules do not stop.

Sleep mode is cleared by a reset or any interrupt, and the CPU returns to the normal program execution state via the exception handling state. Sleep mode is not cleared if interrupts are disabled, or if interrupts other than NMI are masked by the CPU.

When the $\overline{\text{STBY}}$ pin is driven low, a transition is made to hardware standby mode.

19.5 Module Stop Mode

19.5.1 Module Stop Mode

Module stop mode can be set for individual on-chip supporting modules.

When the corresponding MSTP bit in MSTPCR is set to 1, module operation stops at the end of the bus cycle and a transition is made to module stop mode. The CPU continues operating independently.

Table 19-3 shows MSTP bits and the corresponding on-chip supporting modules.

When the corresponding MSTP bit is cleared to 0, module stop mode is cleared and the module starts operating at the end of the bus cycle. In module stop mode, the internal states of modules other than the SCI and A/D converter are retained.

After reset clearance, all modules other than DTC are in module stop mode.

When an on-chip supporting module is in module stop mode, read/write access to its registers is disabled.

If a transition is made to sleep mode when all modules are stopped (MSTPCR = H'FFFF), or modules other than the 8-bit timers are stopped (MSTPCR = H'EFFF), operation of the bus controller and I/O ports is also halted, enabling current dissipation to be further reduced.

Table 19-3 MSTP Bits and Corresponding On-Chip Supporting Modules

Register	Bit	Module
MSTPCRH	MSTP15	—
	MSTP14	Data transfer controller (DTC)
	MSTP13	16-bit timer pulse unit (TPU)
	MSTP12	8-bit timer
	MSTP11	—
	MSTP10	D/A converter*
	MSTP9	A/D converter
	MSTP8	—
MSTPCRL	MSTP7	Serial communication interface (SCI) channel 2
	MSTP6	Serial communication interface (SCI) channel 1
	MSTP5	Serial communication interface (SCI) channel 0
	MSTP4	—
	MSTP3	—
	MSTP2	—
	MSTP1	—
	MSTP0	—

Note: Bits 15, 11, 8, and 4 to 0 can be read or written to, but do not affect operation.

* In the H8S/2393 bit 10 can be read and written to but has no effect on operation, as a D/A converter is not supported.

19.5.2 Usage Notes

DTC Module Stop: Depending on the operating status of the DTC, the MSTP14 bit may not be set to 1. Setting of the DTC module stop mode should be carried out only when the respective module is not activated.

For details, refer to section 7, Data Transfer Controller (DTC).

On-Chip Supporting Module Interrupt: Relevant interrupt operations cannot be performed in module stop mode. Consequently, if module stop mode is entered when an interrupt has been requested, it will not be possible to clear the CPU interrupt source or the DTC activation source. Interrupts should therefore be disabled before entering module stop mode.

Writing to MSTPCR: MSTPCR should only be written to by the CPU.

19.6 Software Standby Mode

19.6.1 Software Standby Mode

If a SLEEP instruction is executed when the SSBY bit in SBYCR is set to 1, software standby mode is entered. In this mode, the CPU, on-chip supporting modules, and oscillator all stop. However, the contents of the CPU's internal registers, RAM data, and the states of on-chip supporting modules other than the SCI and A/D converter, and I/O ports, are retained. Whether the address bus and bus control signals are placed in the high-impedance state or retain the output state can be specified by the OPE bit in SBYCR.

In this mode the oscillator stops, and therefore power dissipation is significantly reduced.

19.6.2 Clearing Software Standby Mode

Software standby mode is cleared by an external interrupt (NMI pin, or pins $\overline{\text{IRQ0}}$ to $\overline{\text{IRQ2}}$), or by means of the $\overline{\text{RES}}$ pin or $\overline{\text{STBY}}$ pin.

- Clearing with an interrupt

When an NMI or IRQ0 to IRQ2 interrupt request signal is input, clock oscillation starts, and after the elapse of the time set in bits STS2 to STS0 in SYSCR, stable clocks are supplied to the entire H8S/2355 Series chip, software standby mode is cleared, and interrupt exception handling is started.

When clearing software standby mode with an IRQ0 to IRQ2 interrupt, set the corresponding enable bit to 1 and ensure that no interrupt with a higher priority than interrupts IRQ0 to IRQ2 is generated. Software standby mode cannot be cleared if the interrupt has been masked on the CPU side or has been designated as a DTC activation source.

- Clearing with the $\overline{\text{RES}}$ pin

When the $\overline{\text{RES}}$ pin is driven low, clock oscillation is started. At the same time as clock oscillation starts, clocks are supplied to the entire H8S/2355 Series chip. Note that the $\overline{\text{RES}}$ pin must be held low until clock oscillation stabilizes. When the $\overline{\text{RES}}$ pin goes high, the CPU begins reset exception handling.

- Clearing with the $\overline{\text{STBY}}$ pin

When the $\overline{\text{STBY}}$ pin is driven low, a transition is made to hardware standby mode.

19.6.3 Setting Oscillation Stabilization Time after Clearing Software Standby Mode

Bits STS2 to STS0 in SBYCR should be set as described below.

Using a Crystal Oscillator: Set bits STS2 to STS0 so that the standby time is at least 8 ms (the oscillation stabilization time).

Table 19-4 shows the standby times for different operating frequencies and settings of bits STS2 to STS0.

Table 19-4 Oscillation Stabilization Time Settings

STS2	STS1	STS0	Standby Time	20 MHz	16 MHz	12 MHz	10 MHz	8 MHz	6 MHz	4 MHz	2 MHz	Unit
0	0	0	8192 states	0.41	0.51	0.68	0.8	1.0	1.3	2.0	4.1	ms
		1	16384 states	0.82	1.0	1.3	1.6	2.0	2.7	4.1	8.2	
	1	0	32768 states	1.6	2.0	2.7	3.3	4.1	5.5	8.2	16.4	
		1	65536 states	3.3	4.1	5.5	6.6	8.2	10.9	16.4	32.8	
1	0	0	131072 states	6.6	8.2	10.9	13.1	16.4	21.8	32.8	65.5	
		1	262144 states	13.1	16.4	21.8	26.2	32.8	43.6	65.6	131.2	
	1	0	Reserved	—	—	—	—	—	—	—	—	
		1	16 states	0.8	1.0	1.3	1.6	2.0	2.7	4.0	8.0	

 : Recommended time setting

Using an External Clock: Any value can be set. Normally, use of the minimum time is recommended.

19.6.4 Software Standby Mode Application Example

Figure 19-2 shows an example in which a transition is made to software standby mode at the falling edge on the NMI pin, and software standby mode is cleared at the rising edge on the NMI pin.

In this example, an NMI interrupt is accepted with the NMIEG bit in SYSCR cleared to 0 (falling edge specification), then the NMIEG bit is set to 1 (rising edge specification), the SSBY bit is set to 1, and a SLEEP instruction is executed, causing a transition to software standby mode.

Software standby mode is then cleared at the rising edge on the NMI pin.

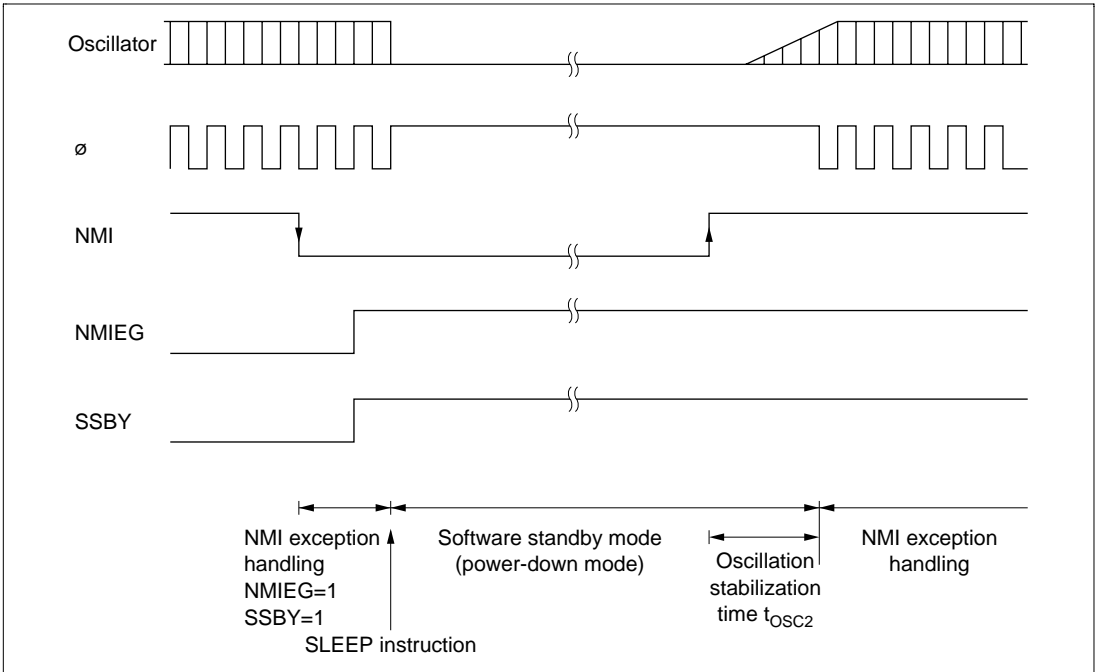

Figure 19-2 Software Standby Mode Application Example

19.6.5 Usage Notes

I/O Port Status: In software standby mode, I/O port states are retained. If the OPE bit is set to 1, the address bus and bus control signal output is also retained. Therefore, there is no reduction in current dissipation for the output current when a high-level signal is output.

Current Dissipation during Oscillation Stabilization Wait Period: Current dissipation increases during the oscillation stabilization wait period.

19.7 Hardware Standby Mode

19.7.1 Hardware Standby Mode

When the $\overline{\text{STBY}}$ pin is driven low, a transition is made to hardware standby mode from any mode.

In hardware standby mode, all functions enter the reset state and stop operation, resulting in a significant reduction in power dissipation. As long as the prescribed voltage is supplied, on-chip RAM data is retained. I/O ports are set to the high-impedance state.

In order to retain on-chip RAM data, the RAME bit in SYSCR should be cleared to 0 before driving the $\overline{\text{STBY}}$ pin low.

Do not change the state of the mode pins (MD_2 to MD_0) while the H8S/2355 Series is in hardware standby mode.

Hardware standby mode is cleared by means of the $\overline{\text{STBY}}$ pin and the $\overline{\text{RES}}$ pin. When the $\overline{\text{STBY}}$ pin is driven high while the $\overline{\text{RES}}$ pin is low, the reset state is set and clock oscillation is started. Ensure that the $\overline{\text{RES}}$ pin is held low until the clock oscillator stabilizes (at least 8 ms—the oscillation stabilization time—when using a crystal oscillator). When the $\overline{\text{RES}}$ pin is subsequently driven high, a transition is made to the program execution state via the reset exception handling state.

19.7.2 Hardware Standby Mode Timing

Figure 19-3 shows an example of hardware standby mode timing.

When the $\overline{\text{STBY}}$ pin is driven low after the $\overline{\text{RES}}$ pin has been driven low, a transition is made to hardware standby mode. Hardware standby mode is cleared by driving the $\overline{\text{STBY}}$ pin high, waiting for the oscillation stabilization time, then changing the $\overline{\text{RES}}$ pin from low to high.

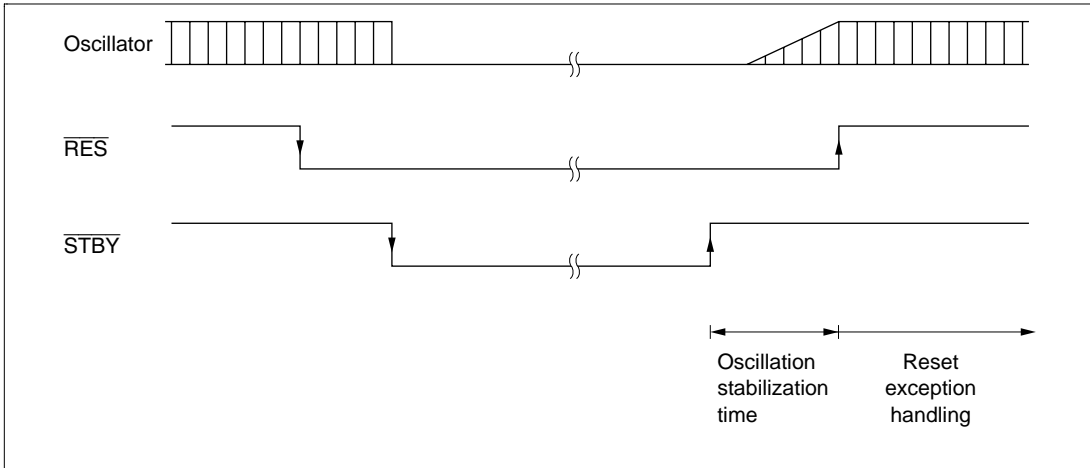

Figure 19-3 Hardware Standby Mode Timing (Example)

19.8 ϕ Clock Output Disabling Function

Output of the ϕ clock can be controlled by means of the PSTOP bit in SCKCR, and DDR for the corresponding port. When the PSTOP bit is set to 1, the ϕ clock stops at the end of the bus cycle, and ϕ output goes high. ϕ clock output is enabled when the PSTOP bit is cleared to 0. When DDR for the corresponding port is cleared to 0, ϕ clock output is disabled and input port mode is set. Table 19-5 shows the state of the ϕ pin in each processing state.

Table 19-5 ϕ Pin State in Each Processing State

DDR	0	1	
PSTOP	—	0	1
Hardware standby mode	High impedance		
Software standby mode	High impedance	Fixed high	
Sleep mode	High impedance	ϕ output	Fixed high
Normal operating state	High impedance	ϕ output	Fixed high

20.1 Absolute Maximum Ratings

Table 20-1 lists the absolute maximum ratings.

Table 20-1 Absolute Maximum Ratings

Item	Symbol	Value	Unit
Power supply voltage	V_{CC}	-0.3 to +7.0	V
Programming voltage	V_{PP}	-0.3 to +13.5	V
Input voltage (except port 4)	V_{in}	-0.3 to $V_{CC} + 0.3$	V
Input voltage (port 4)	V_{in}	-0.3 to $AV_{CC} + 0.3$	V
Reference voltage	V_{ref}	-0.3 to $AV_{CC} + 0.3$	V
Analog power supply voltage	AV_{CC}	-0.3 to +7.0	V
Analog input voltage	V_{AN}	-0.3 to $AV_{CC} + 0.3$	V
Operating temperature	T_{opr}	Regular specifications: -20 to +75	°C
		Wide-range specifications: -40 to +85	°C
Storage temperature	T_{stg}	-55 to +125	°C

Caution: Permanent damage to the chip may result if absolute maximum rating are exceeded.

20.2 DC Characteristics

Table 20-2 lists the DC characteristics. Table 20-3 lists the permissible output currents.

Table 20-2 DC Characteristics (1)

Conditions: $V_{CC} = 5.0 \text{ V} \pm 10\%$, $AV_{CC} = 5.0 \text{ V} \pm 10\%$, $V_{ref} = 4.5 \text{ V}$ to AV_{CC} , $V_{SS} = AV_{SS} = 0 \text{ V}^{*1}$,
 $T_a = -20$ to $+75^\circ\text{C}$ (regular specifications), $T_a = -40$ to $+85^\circ\text{C}$ (wide-range specifications)

Item	Symbol	Min	Typ	Max	Unit	Test Conditions	
Schmitt trigger input voltage	Port 2, P6 ₄ to P6 ₇ , PA ₄ to PA ₇	V_T^-	1.0	—	—	V	
		V_T^+	—	—	$V_{CC} \times 0.7$	V	
		$V_T^+ - V_T^-$	0.4	—	—	V	
Input high voltage	\overline{RES} , \overline{STBY} , NMI, MD ₂ to MD ₀	V_{IH}	$V_{CC} - 0.7$	—	$V_{CC} + 0.3$	V	
	EXTAL		$V_{CC} \times 0.7$	—	$V_{CC} + 0.3$	V	
	Port 1, 3, 5, B to G, P6 ₀ to P6 ₃ , PA ₀ to PA ₃		2.0	—	$V_{CC} + 0.3$	V	
	Port4		2.0	—	$AV_{CC} + 0.3$	V	
Input low voltage	\overline{RES} , \overline{STBY} , MD ₂ to MD ₀	V_{IL}	-0.3	—	0.5	V	
	NMI, EXTAL, Port 1, 3 to 5, B to G, P6 ₀ to P6 ₃ , PA ₀ to PA ₃		-0.3	—	0.8	V	
Output high voltage	All output pins	V_{OH}	$V_{CC} - 0.5$	—	—	V	$I_{OH} = -200 \mu\text{A}$
			3.5	—	—	V	$I_{OH} = -1 \text{ mA}$
Output low voltage	All output pins	V_{OL}	—	—	0.4	V	$I_{OL} = 1.6 \text{ mA}$
	Port 1, A to C		—	—	1.0	V	$I_{OL} = 10 \text{ mA}$
Input leakage current	\overline{RES}	$ I_{in} $	—	—	10.0	μA	$V_{in} =$ 0.5 to $V_{CC} - 0.5 \text{ V}$
	\overline{STBY} , NMI, MD ₂ to MD ₀		—	—	1.0	μA	
	Port 4		—	—	1.0	μA	

Item		Symbol	Min	Typ	Max	Unit	Test Conditions
Three-state leakage current (off state)	Port 1 to 3, 5, 6, A to G	$ I_{TSL} $	—	—	1.0	μA	$V_{in} = 0.5 \text{ to } V_{CC} - 0.5 \text{ V}$
MOS input pull-up current	Port A to E	$-I_p$	50	—	300	μA	$V_{in} = 0 \text{ V}$
Input capacitance	$\overline{\text{RES}}$	C_{in}	—	—	80	pF	$V_{in} = 0 \text{ V}$ $f = 1 \text{ MHz}$ $T_a = 25^\circ\text{C}$
	NMI		—	—	50	pF	
	All input pins except RES and NMI		—	—	15	pF	
Current dissipation* ²	Normal operation	I_{CC}^{*4}	—	60 (5.0 V)	89	mA	$f = 20 \text{ MHz}$
	Sleep mode		—	40 (5.0 V)	73	mA	$f = 20 \text{ MHz}$
	Standby mode* ³		—	0.01	5.0	μA	$T_a \leq 50^\circ\text{C}$
Analog power supply current	During A/D and D/A conversion	AI_{CC}	—	0.8 (5.0 V)	2.0	mA	
	Idle		—	0.01	5.0	μA	
Reference current	During A/D and D/A conversion	AI_{CC}	—	1.9 (5.0 V)	3.0	mA	
	Idle		—	0.01	5.0	μA	
RAM standby voltage		V_{RAM}	2.0	—	—	V	

Notes: 1. If the A/D and D/A converters are not used, do not leave the AV_{CC} , AV_{SS} , and V_{ref} pins open.

Connect AV_{CC} and V_{ref} to V_{CC} , and connect AV_{SS} to V_{SS} .

- Current dissipation values are for $V_{IH} \text{ min} = V_{CC} - 0.5 \text{ V}$ and $V_{IL} \text{ max} = 0.5 \text{ V}$ with all output pins unloaded and the on-chip pull-up transistors in the off state.
- The values are for $V_{RAM} \leq V_{CC} < 4.5 \text{ V}$, $V_{IH} \text{ min} = V_{CC} \times 0.9$, and $V_{IL} \text{ max} = 0.3 \text{ V}$.
- I_{CC} depends on V_{CC} and f as follows:
 $I_{CC} \text{ max} = 1.0 \text{ (mA)} + 0.80 \text{ (mA/(MHz} \times \text{V))} \times V_{CC} \times f$ [normal mode]
 $I_{CC} \text{ max} = 1.0 \text{ (mA)} + 0.65 \text{ (mA/(MHz} \times \text{V))} \times V_{CC} \times f$ [sleep mode]

Table 20-2 DC Characteristics (2)

Conditions: $V_{CC} = 2.7$ to 5.5 V, $AV_{CC} = 2.7$ to 5.5 V, $V_{ref} = 2.7$ V to AV_{CC} , $V_{SS} = AV_{SS} = 0$ V*1,
 $T_a = -20$ to $+75^\circ\text{C}$ (regular specifications), $T_a = -40$ to $+85^\circ\text{C}$ (wide-range specifications)

Item	Symbol	Min	Typ	Max	Unit	Test Conditions	
Schmitt trigger input voltage	Port 2, P6 ₄ to P6 ₇ , PA ₄ to PA ₇	V_T^-	$V_{CC} \times 0.2$	—	—	V	
		V_T^+	—	—	$V_{CC} \times 0.7$	V	
		$V_T^+ - V_T^-$	$V_{CC} \times 0.07$	—	—	V	
Input high voltage	\overline{RES} , \overline{STBY} , NMI, MD ₂ to MD ₀	V_{IH}	$V_{CC} \times 0.9$	—	$V_{CC} + 0.3$	V	
	EXTAL		$V_{CC} \times 0.7$	—	$V_{CC} + 0.3$	V	
	Port 1, 3, 5, B to G, P6 ₀ to P6 ₃ , PA ₀ to PA ₃		$V_{CC} \times 0.7$	—	$V_{CC} + 0.3$	V	
	Port 4		$V_{CC} \times 0.7$	—	$AV_{CC} + 0.3$	V	
Input low voltage	\overline{RES} , \overline{STBY} , MD ₂ to MD ₀	V_{IL}	-0.3	—	$V_{CC} \times 0.1$	V	
	NMI, EXTAL, Port 1, 3 to 5, B to G, P6 ₀ to P6 ₃ , PA ₀ to PA ₃		-0.3	—	$V_{CC} \times 0.2$	V $V_{CC} < 4.0$ V	
					0.8	$V_{CC} = 4.0$ to 5.5 V	
Output high voltage	All output pins	V_{OH}	$V_{CC} - 0.5$	—	—	V	$I_{OH} = -200$ μA
			$V_{CC} - 1.0$	—	—	V	$I_{OH} = -1$ mA
Output low voltage	All output pins	V_{OL}	—	—	0.4	V	$I_{OL} = 1.6$ mA
	Port 1, A to C		—	—	1.0	V	$V_{CC} \leq 4$ V $I_{OL} = 5$ mA $4.0 < V_{CC} \leq 5.5$ V $I_{OL} = 10$ mA
Input leakage current	\overline{RES}	$ I_{in} $	—	—	10.0	μA	$V_{in} =$ 0.5 to $V_{CC} - 0.5$ V
	\overline{STBY} , NMI, MD ₂ to MD ₀		—	—	1.0	μA	
	Port 4		—	—	1.0	μA	$V_{in} =$ 0.5 to $AV_{CC} - 0.5$ V

Item		Symbol	Min	Typ	Max	Unit	Test Conditions
Three-state leakage current (off state)	Port 1 to 3, 5, 6, A to G	$ I_{TSL} $	—	—	1.0	μA	$V_{in} = 0.5 \text{ to } V_{CC} - 0.5 \text{ V}$
MOS input pull-up current	Port A to E	$-I_p$	10	—	300	μA	$V_{CC} = 2.7 \text{ V to } 5.5 \text{ V}, V_{in} = 0 \text{ V}$
Input capacitance	$\overline{\text{RES}}$	C_{in}	—	—	80	pF	$V_{in} = 0 \text{ V}$ $f = 1 \text{ MHz}$ $T_a = 25^\circ\text{C}$
	NMI		—	—	50	pF	
	All input pins except RES and NMI		—	—	15	pF	
Current dissipation* ²	Normal operation	I_{CC}^{*4}	—	18 (3.0 V)	45	mA	$f = 10 \text{ MHz}$
	Sleep mode		—	11 (3.0 V)	37	mA	$f = 10 \text{ MHz}$
	Standby mode* ³		—	0.01	5.0	μA	$T_a \leq 50^\circ\text{C}$
—		—	—	20		$50^\circ\text{C} < T_a$	
Analog power supply current	During A/D and D/A conversion	AI_{CC}	—	0.2 (3.0 V)	2.0	mA	
	Idle		—	0.01	5.0	μA	
Reference current	During A/D and D/A conversion	AI_{CC}	—	1.2 (3.0 V)	3.0	mA	
	Idle		—	0.01	5.0	μA	
RAM standby voltage		V_{RAM}	2.0	—	—	V	

Notes: 1. If the A/D and D/A converters are not used, do not leave the AV_{CC} , AV_{SS} , and V_{ref} pins open.

Connect AV_{CC} and V_{ref} to V_{CC} , and connect AV_{SS} to V_{SS} .

- Current dissipation values are for $V_{IH} \text{ min} = V_{CC} - 0.5 \text{ V}$ and $V_{IL} \text{ max} = 0.5 \text{ V}$ with all output pins unloaded and the on-chip pull-up transistors in the off state.
- The values are for $V_{RAM} \leq V_{CC} < 2.7 \text{ V}$, $V_{IH} \text{ min} = V_{CC} \times 0.9$, and $V_{IL} \text{ max} = 0.3 \text{ V}$.
- I_{CC} depends on V_{CC} and f as follows:
 $I_{CC} \text{ max} = 1.0 \text{ (mA)} + 0.80 \text{ (mA/(MHz} \times \text{V))} \times V_{CC} \times f$ [normal mode]
 $I_{CC} \text{ max} = 1.0 \text{ (mA)} + 0.65 \text{ (mA/(MHz} \times \text{V))} \times V_{CC} \times f$ [sleep mode]

Table 20-2 DC Characteristics (3)

Conditions: $V_{CC} = 3.0$ to 5.5 V, $AV_{CC} = 3.0$ to 5.5 V, $V_{ref} = 3.0$ V to AV_{CC} , $V_{SS} = AV_{SS} = 0$ V*1,
 $T_a = -20$ to $+75^\circ\text{C}$ (regular specifications), $T_a = -40$ to $+85^\circ\text{C}$ (wide-range specifications)

Item	Symbol	Min	Typ	Max	Unit	Test Conditions	
Schmitt trigger input voltage	Port 2, P6 ₄ to P6 ₇ , PA ₄ to PA ₇	V_T^-	$V_{CC} \times 0.2$	—	—	V	
		V_T^+	—	—	$V_{CC} \times 0.7$	V	
		$V_T^+ - V_T^-$	$V_{CC} \times 0.07$	—	—	V	
Input high voltage	\overline{RES} , \overline{STBY} , NMI, MD ₂ to MD ₀	V_{IH}	$V_{CC} \times 0.9$	—	$V_{CC} + 0.3$	V	
	EXTAL		$V_{CC} \times 0.7$	—	$V_{CC} + 0.3$	V	
	Port 1, 3, 5, B to G, P6 ₀ to P6 ₃ , PA ₀ to PA ₃		$V_{CC} \times 0.7$	—	$V_{CC} + 0.3$	V	
	Port 4		$V_{CC} \times 0.7$	—	$AV_{CC} + 0.3$	V	
Input low voltage	\overline{RES} , \overline{STBY} , MD ₂ to MD ₀	V_{IL}	-0.3	—	$V_{CC} \times 0.1$	V	
	NMI, EXTAL, Port 1, 3 to 5, B to G, P6 ₀ to P6 ₃ , PA ₀ to PA ₃		-0.3	—	$V_{CC} \times 0.2$	V $V_{CC} < 4.0$ V	
					0.8	$V_{CC} = 4.0$ to 5.5 V	
Output high voltage	All output pins	V_{OH}	$V_{CC} - 0.5$	—	—	V	$I_{OH} = -200$ μA
			$V_{CC} - 1.0$	—	—	V	$I_{OH} = -1$ mA
Output low voltage	All output pins Port 1, A to C	V_{OL}	—	—	0.4	V	$I_{OL} = 1.6$ mA
			—	—	1.0	V	$V_{CC} \leq 4$ V $I_{OL} = 5$ mA $4.0 < V_{CC} \leq 5.5$ V $I_{OL} = 10$ mA
Input leakage current	\overline{RES}	$ I_{in} $	—	—	10.0	μA	$V_{in} =$ 0.5 to $V_{CC} - 0.5$ V
	\overline{STBY} , NMI, MD ₂ to MD ₀		—	—	1.0	μA	
	Port 4		—	—	1.0	μA	$V_{in} =$ 0.5 to $AV_{CC} - 0.5$ V

Item		Symbol	Min	Typ	Max	Unit	Test Conditions
Three-state leakage current (off state)	Port 1 to 3, 5, 6, A to G	$ I_{TSL} $	—	—	1.0	μA	$V_{in} = 0.5 \text{ to } V_{CC} - 0.5 \text{ V}$
MOS input pull-up current	Port A to E	$-I_p$	10	—	300	μA	$V_{CC} = 3.0 \text{ V to } 5.5 \text{ V}, V_{in} = 0 \text{ V}$
Input capacitance	$\overline{\text{RES}}$	C_{in}	—	—	80	pF	$V_{in} = 0 \text{ V}$ $f = 1 \text{ MHz}$ $T_a = 25^\circ\text{C}$
	NMI		—	—	50	pF	
	All input pins except RES and NMI		—	—	15	pF	
Current dissipation* ²	Normal operation	I_{CC}^{*4}	—	25 (3.3 V)	58	mA	$f = 13 \text{ MHz}$
	Sleep mode		—	16 (3.3 V)	48	mA	$f = 13 \text{ MHz}$
	Standby mode* ³			—	0.01	5.0	μA
			—	—	20.0		$50^\circ\text{C} < T_a$
Analog power supply current	During A/D and D/A conversion	AI_{CC}	—	0.2 (3.3 V)	2.0	mA	
	Idle		—	0.01	5.0	μA	
Reference current	During A/D and D/A conversion	AI_{CC}	—	1.2 (3.3 V)	3.0	mA	
	Idle		—	0.01	5.0	μA	
RAM standby voltage		V_{RAM}	2.0	—	—	V	

Notes: 1. If the A/D and D/A converters are not used, do not leave the AV_{CC} , AV_{SS} , and V_{ref} pins open.

Connect AV_{CC} and V_{ref} to V_{CC} , and connect AV_{SS} to V_{SS} .

- Current dissipation values are for $V_{IH} \text{ min} = V_{CC} - 0.5 \text{ V}$ and $V_{IL} \text{ max} = 0.5 \text{ V}$ with all output pins unloaded and the on-chip pull-up transistors in the off state.
- The values are for $V_{RAM} \leq V_{CC} < 3.0 \text{ V}$, $V_{IH} \text{ min} = V_{CC} \times 0.9$, and $V_{IL} \text{ max} = 0.3 \text{ V}$.
- I_{CC} depends on V_{CC} and f as follows:
 $I_{CC} \text{ max} = 1.0 \text{ (mA)} + 0.80 \text{ (mA/(MHz} \times \text{V))} \times V_{CC} \times f$ [normal mode]
 $I_{CC} \text{ max} = 1.0 \text{ (mA)} + 0.65 \text{ (mA/(MHz} \times \text{V))} \times V_{CC} \times f$ [sleep mode]

Table 20-3 Permissible Output Currents

Conditions: $V_{CC} = 2.7$ to 5.5 V, $AV_{CC} = 2.7$ to 5.5 V, $V_{ref} = 2.7$ to AV_{CC} , $V_{SS} = AV_{SS} = 0$ V,
 $T_a = -20$ to $+75^\circ\text{C}$ (regular specifications), $T_a = -40$ to $+85^\circ\text{C}$ (wide-range specifications)

Item		Symbol	Min	Typ	Max	Unit
Permissible output low current (per pin)	Port 1, A to C	I_{OL}	—	—	10	mA
	Other output pins		—	—	2.0	mA
Permissible output low current (total)	Total of 32 pins including port 1 and A to C	ΣI_{OL}	—	—	80	mA
	Total of all output pins, including the above		—	—	120	mA
Permissible output high current (per pin)	All output pins	$-I_{OH}$	—	—	2.0	mA
Permissible output high current (total)	Total of all output pins	$\Sigma -I_{OH}$	—	—	40	mA

Notes: 1. To protect chip reliability, do not exceed the output current values in table 20-3.

2. When driving a darlington pair or LED directly, always insert a current-limiting resistor in the output line, as show in figures 20-1 and 20-2.

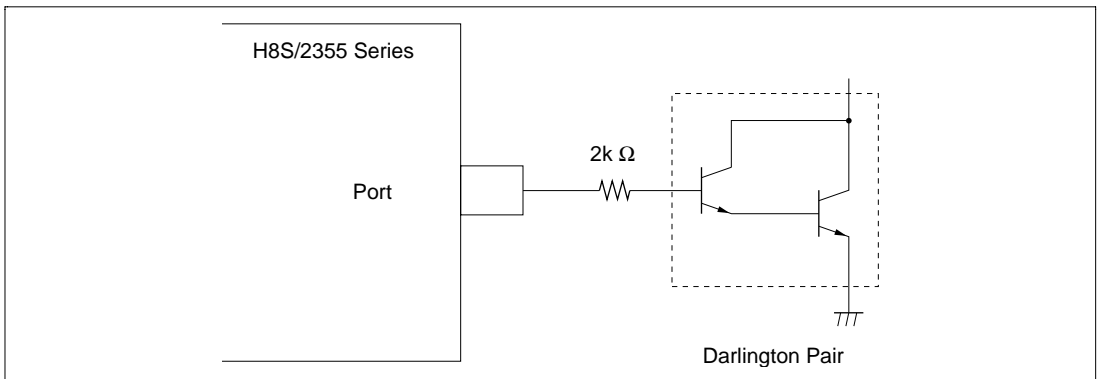

Figure 20-1 Darlington Pair Drive Circuit (Example)

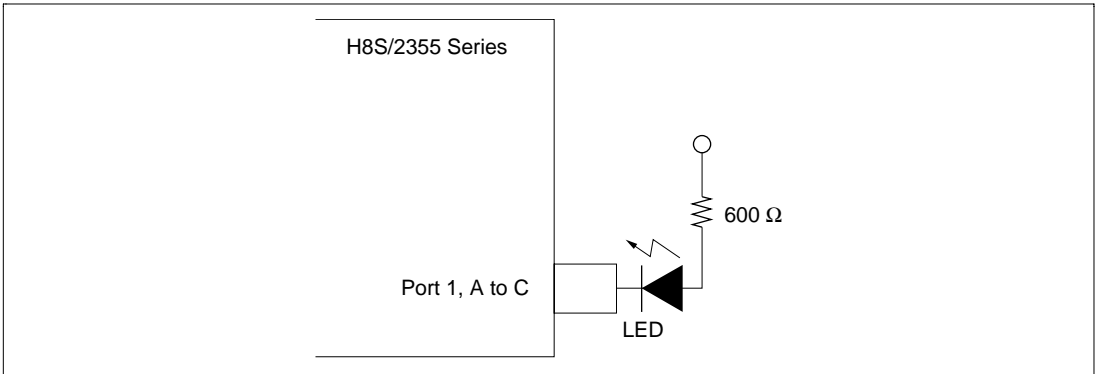

Figure 20-2 LED Drive Circuit (Example)

20.3 AC Characteristics

Figure 20-3 show, the test conditions for the AC characteristics.

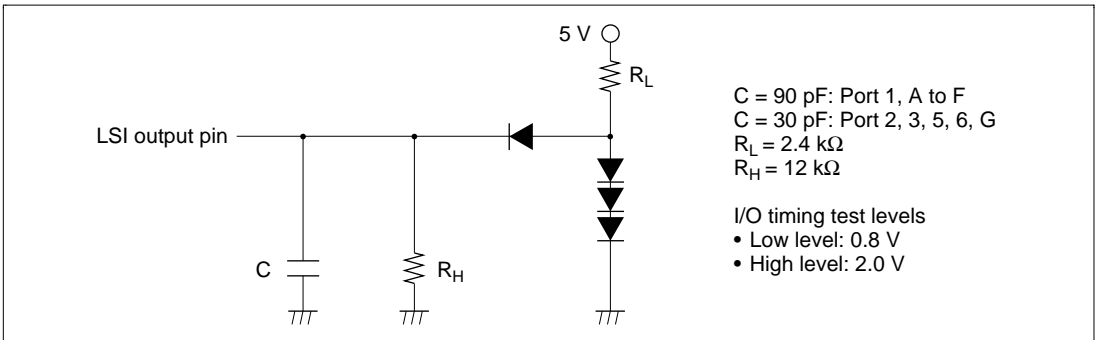

Figure 20-3 Output Load Circuit

20.3.1 Clock Timing

Table 20-4 lists the clock timing

Table 20-4 Clock Timing

Condition A: $V_{CC} = 2.7$ to 5.5 V, $AV_{CC} = 2.7$ to 5.5 V, $V_{ref} = 2.7$ V to AV_{CC} ,
 $V_{SS} = AV_{SS} = 0$ V, $\phi = 2$ to 10 MHz, $T_a = -20$ to $+75^\circ\text{C}$ (regular specifications),
 $T_a = -40$ to $+85^\circ\text{C}$ (wide-range specifications)

Condition B: $V_{CC} = 5.0$ V $\pm 10\%$, $AV_{CC} = 5.0$ V $\pm 10\%$, $V_{ref} = 4.5$ V to AV_{CC} ,
 $V_{SS} = AV_{SS} = 0$ V, $\phi = 2$ to 20 MHz, $T_a = -20$ to $+75^\circ\text{C}$ (regular specifications),
 $T_a = -40$ to $+85^\circ\text{C}$ (wide-range specifications)

Condition C: (mask ROM version only)
 $V_{CC} = 3.0$ to 5.5 V, $AV_{CC} = 3.0$ to 5.5 V, $V_{ref} = 3.0$ V to AV_{CC} ,
 $V_{SS} = AV_{SS} = 0$ V, $\phi = 2$ to 13 MHz, $T_a = -20$ to $+75^\circ\text{C}$ (regular specifications),
 $T_a = -40$ to $+85^\circ\text{C}$ (wide-range specifications)

Item	Symbol	Condition A		Condition B		Condition C		Unit	Test Conditions
		Min	Max	Min	Max	Min	Max		
Clock cycle time	t_{cyc}	100	500	50	500	76	500	ns	Figure 20-4
Clock high pulse width	t_{CH}	35	—	20	—	23	—	ns	Figure 20-4
Clock low pulse width	t_{CL}	35	—	20	—	23	—	ns	
Clock rise time	t_{Cr}	—	15	—	5	—	15	ns	
Clock fall time	t_{Cf}	—	15	—	5	—	15	ns	
Clock oscillator setting time at reset (crystal)	t_{OSC1}	20	—	10	—	20	—	ms	Figure 20-5
Clock oscillator setting time in software standby (crystal)	t_{OSC2}	8	—	8	—	20	—	ms	Figure 19-2
External clock output stabilization delay time	t_{DEXT}	500	—	500	—	500	—	μs	Figure 20-5

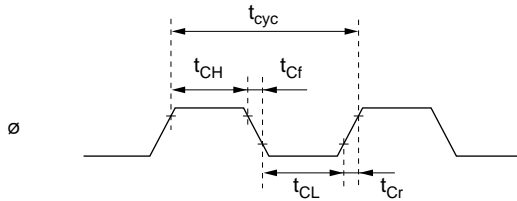

Figure 20-4 System Clock Timing

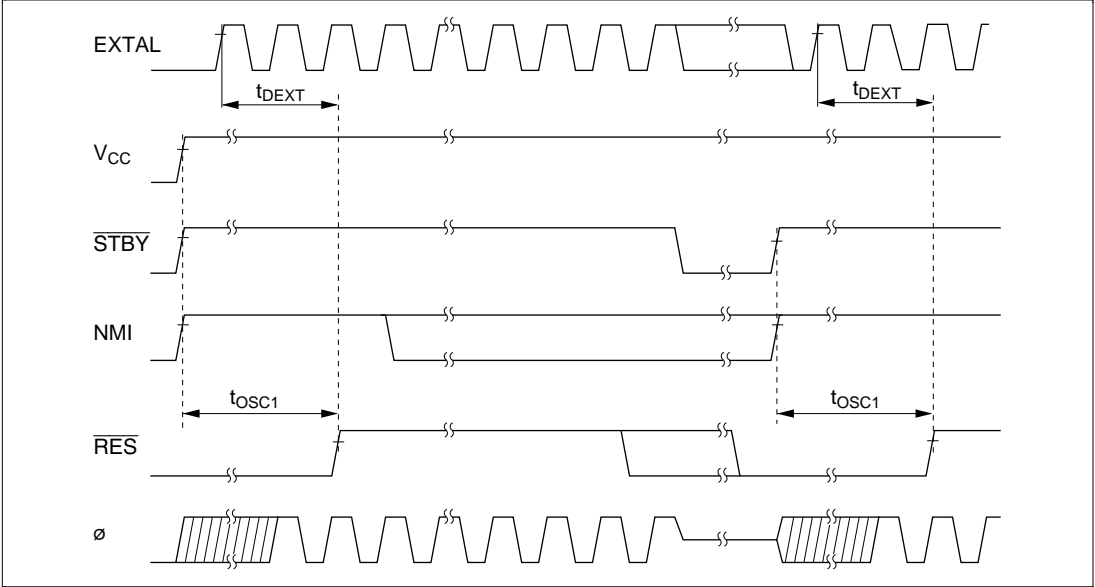

Figure 20-5 Oscillator Settling Timing

20.3.2 Control Signal Timing

Table 20-5 lists the control signal timing.

Table 20-5 Control Signal Timing

Condition A: $V_{CC} = 2.7$ to 5.5 V, $AV_{CC} = 2.7$ to 5.5 V, $V_{ref} = 2.7$ V to AV_{CC} ,
 $V_{SS} = AV_{SS} = 0$ V, $\phi = 2$ to 10 MHz, $T_a = -20$ to $+75^\circ\text{C}$ (regular specifications),
 $T_a = -40$ to $+85^\circ\text{C}$ (wide-range specifications)

Condition B: $V_{CC} = 5.0$ V $\pm 10\%$, $AV_{CC} = 5.0$ V $\pm 10\%$, $V_{ref} = 4.5$ V to AV_{CC} ,
 $V_{SS} = AV_{SS} = 0$ V, $\phi = 2$ to 20 MHz, $T_a = -20$ to $+75^\circ\text{C}$ (regular specifications),
 $T_a = -40$ to $+85^\circ\text{C}$ (wide-range specifications)

Condition C: (mask ROM version only)
 $V_{CC} = 3.0$ to 5.5 V, $AV_{CC} = 3.0$ to 5.5 V, $V_{ref} = 3.0$ V to AV_{CC} ,
 $V_{SS} = AV_{SS} = 0$ V, $\phi = 2$ to 13 MHz, $T_a = -20$ to $+75^\circ\text{C}$ (regular specifications),
 $T_a = -40$ to $+85^\circ\text{C}$ (wide-range specifications)

Item	Symbol	Condition A		Condition B		Condition C		Unit	Test Conditions
		Min	Max	Min	Max	Min	Max		
$\overline{\text{RES}}$ setup time	t_{RESS}	200	—	200	—	200	—	ns	Figure 20-6
$\overline{\text{RES}}$ pulse width	t_{RESW}	20	—	20	—	20	—	t_{cyc}	
NMI reset setup time	t_{NMIRS}	250	—	200	—	250	—	ns	Figure 20-7
NMI reset hold time	t_{NMIRH}	200	—	200	—	200	—	ns	
NMI setup time	t_{NMIS}	250	—	150	—	250	—	ns	
NMI hold time	t_{NMIH}	10	—	10	—	10	—	ns	
NMI pulse width (exiting software standby mode)	t_{NMIW}	200	—	200	—	200	—	ns	
$\overline{\text{IRQ}}$ setup time	t_{IRQS}	250	—	150	—	250	—	ns	
$\overline{\text{IRQ}}$ hold time	t_{IRQH}	10	—	10	—	10	—	ns	
$\overline{\text{IRQ}}$ pulse width (exiting software standby mode)	t_{IRQW}	200	—	200	—	200	—	ns	

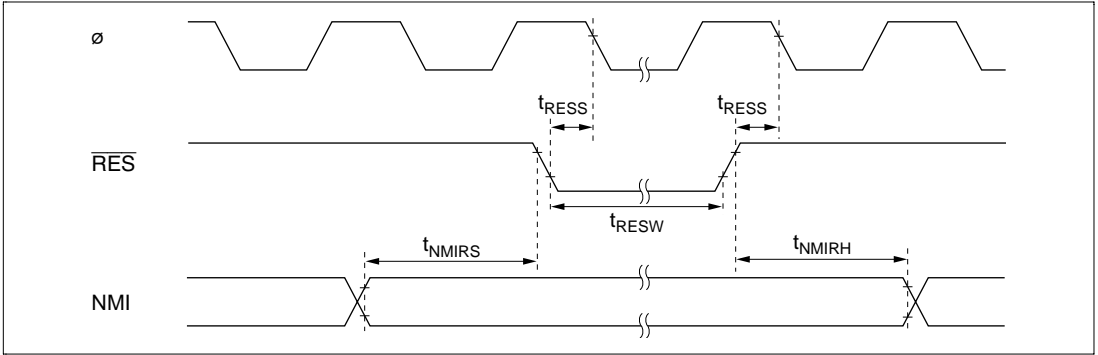

Figure 20-6 Reset Input Timing

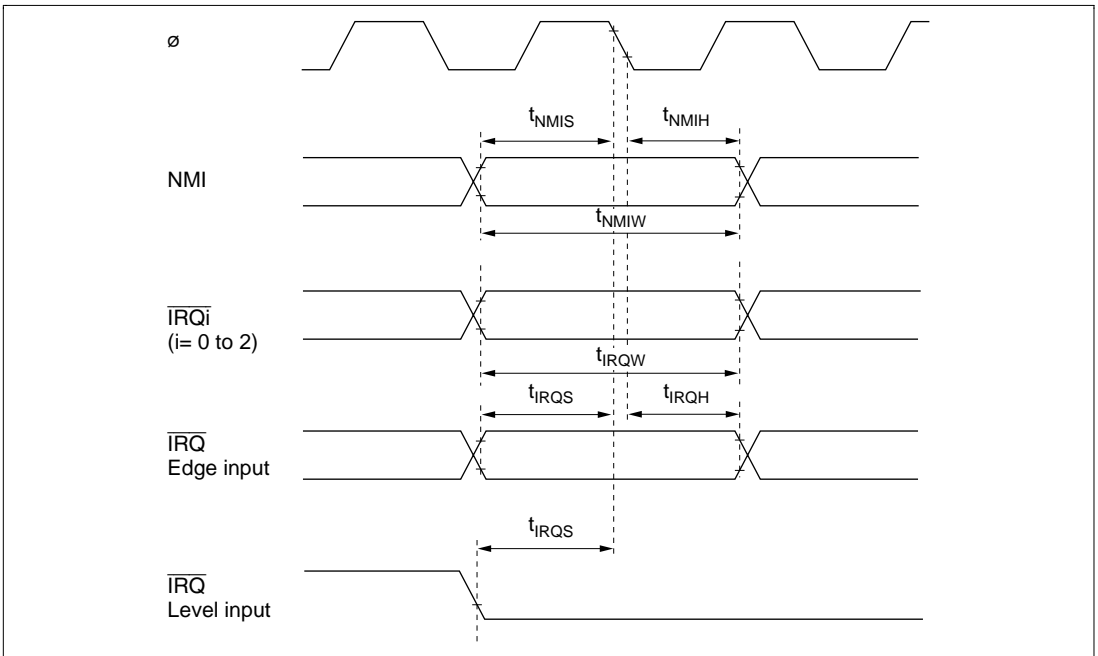

Figure 20-7 Interrupt Input Timing

20.3.3 Bus Timing

Table 20-6 lists the bus timing.

Table 20-6 Bus Timing

Condition A: $V_{CC} = 2.7$ to 5.5 V, $AV_{CC} = 2.7$ to 5.5 V, $V_{ref} = 2.7$ V to AV_{CC} ,
 $V_{SS} = AV_{SS} = 0$ V, $\phi = 2$ to 10 MHz, $T_a = -20$ to $+75^\circ\text{C}$ (regular specifications),
 $T_a = -40$ to $+85^\circ\text{C}$ (wide-range specifications)

Condition B: $V_{CC} = 5.0$ V $\pm 10\%$, $AV_{CC} = 5.0$ V $\pm 10\%$, $V_{ref} = 4.5$ V to AV_{CC} ,
 $V_{SS} = AV_{SS} = 0$ V, $\phi = 2$ to 20 MHz, $T_a = -20$ to $+75^\circ\text{C}$ (regular specifications),
 $T_a = -40$ to $+85^\circ\text{C}$ (wide-range specifications)

Condition C: (mask ROM version only)
 $V_{CC} = 3.0$ to 5.5 V, $AV_{CC} = 3.0$ to 5.5 V, $V_{ref} = 3.0$ V to AV_{CC} ,
 $V_{SS} = AV_{SS} = 0$ V, $\phi = 2$ to 13 MHz, $T_a = -20$ to $+75^\circ\text{C}$ (regular specifications),
 $T_a = -40$ to $+85^\circ\text{C}$ (wide-range specifications)

Item	Symbol	Condition A		Condition B		Condition C		Unit	Test Conditions
		Min	Max	Min	Max	Min	Max		
Address delay time	t_{AD}	—	40	—	20	—	40	ns	Figure 20-8 to Figure 20-12
Address setup time	t_{AS}	$0.5 \times t_{cyc} - 30$	—	$0.5 \times t_{cyc} - 15$	—	$0.5 \times t_{cyc} - 30$	—	ns	
Address hold time	t_{AH}	$0.5 \times t_{cyc} - 20$	—	$0.5 \times t_{cyc} - 10$	—	$0.5 \times t_{cyc} - 20$	—	ns	
\overline{CS} delay time 1	t_{CSD1}	—	40	—	20	—	40	ns	
\overline{AS} delay time	t_{ASD}	—	40	—	20	—	40	ns	
\overline{RD} delay time 1	t_{RSD1}	—	40	—	20	—	40	ns	
\overline{RD} delay time 2	t_{RSD2}	—	40	—	20	—	40	ns	
Read data setup time	t_{RDS}	30	—	15	—	30	—	ns	
Read data hold time	t_{RDH}	0	—	0	—	0	—	ns	
Read data access time1	t_{ACC1}	—	$1.0 \times t_{cyc} - 50$	—	$1.0 \times t_{cyc} - 25$	—	$1.0 \times t_{cyc} - 50$	ns	
Read data access time2	t_{ACC2}	—	$1.5 \times t_{cyc} - 50$	—	$1.5 \times t_{cyc} - 25$	—	$1.5 \times t_{cyc} - 50$	ns	
Read data access time3	t_{ACC3}	—	$2.0 \times t_{cyc} - 50$	—	$2.0 \times t_{cyc} - 25$	—	$2.0 \times t_{cyc} - 50$	ns	

Item	Symbol	Condition A		Condition B		Condition C		Unit	Test Conditions
		Min	Max	Min	Max	Min	Max		
Read data access time 4	t_{ACC4}	—	$2.5 \times t_{cyc} - 50$	—	$2.5 \times t_{cyc} - 25$	—	$2.5 \times t_{cyc} - 50$	ns	Figure 20-8 to Figure 20-12
Read data access time 5	t_{ACC5}	—	$3.0 \times t_{cyc} - 50$	—	$3.0 \times t_{cyc} - 25$	—	$3.0 \times t_{cyc} - 50$	ns	
\overline{WR} delay time 1	t_{WRD1}	—	40	—	20	—	40	ns	
\overline{WR} delay time 2	t_{WRD2}	—	40	—	20	—	40	ns	
\overline{WR} pulse width 1	t_{WSW1}	$1.0 \times t_{cyc} - 40$	—	$1.0 \times t_{cyc} - 20$	—	$1.0 \times t_{cyc} - 40$	—	ns	
\overline{WR} pulse width 2	t_{WSW2}	$1.5 \times t_{cyc} - 40$	—	$1.5 \times t_{cyc} - 20$	—	$1.5 \times t_{cyc} - 40$	—	ns	
Write data delay time	t_{WDD}	—	60	—	30	—	60	ns	
Write data setup time	t_{WDS}	$0.5 \times t_{cyc} - 40$	—	$0.5 \times t_{cyc} - 20$	—	$0.5 \times t_{cyc} - 33$	—	ns	
Write data hold time	t_{WDH}	$0.5 \times t_{cyc} - 20$	—	$0.5 \times t_{cyc} - 10$	—	$0.5 \times t_{cyc} - 20$	—	ns	
\overline{WAIT} setup time	t_{WTS}	60	—	30	—	60	—	ns	Figure 20-10
\overline{WAIT} hold time	t_{WTH}	10	—	5	—	10	—	ns	
\overline{BREQ} setup time	t_{BRQS}	60	—	30	—	60	—	ns	Figure 20-13
\overline{BACK} delay time	t_{BACD}	—	30	—	15	—	30	ns	
Bus-floating time	t_{BZD}	—	100	—	50	—	75	ns	

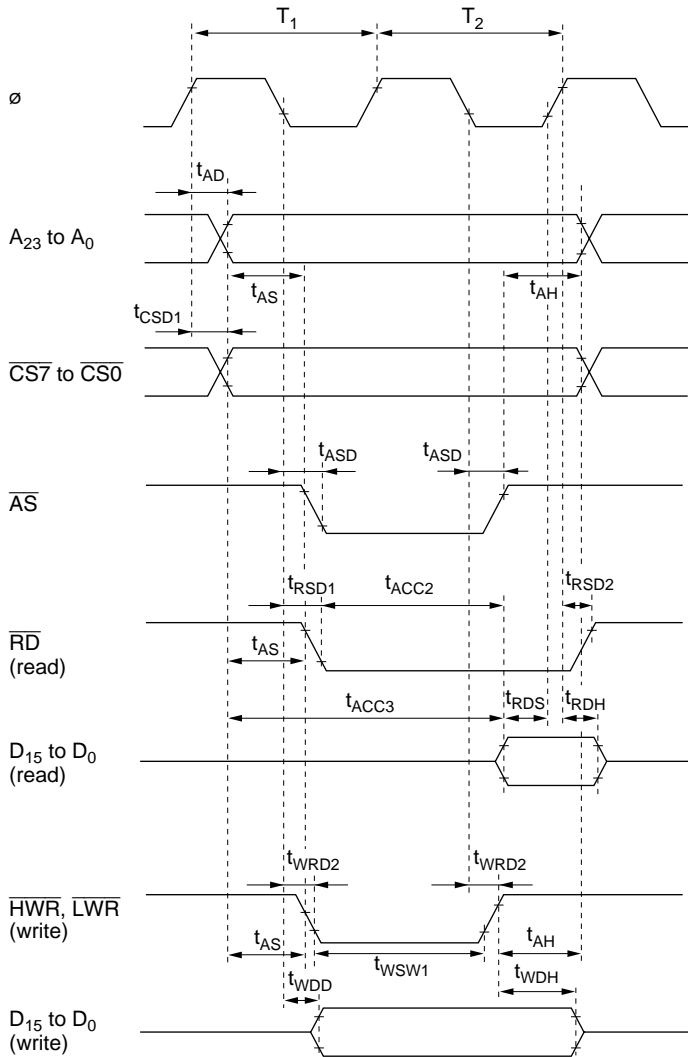

Figure 20-8 Basic Bus Timing (Two-State Access)

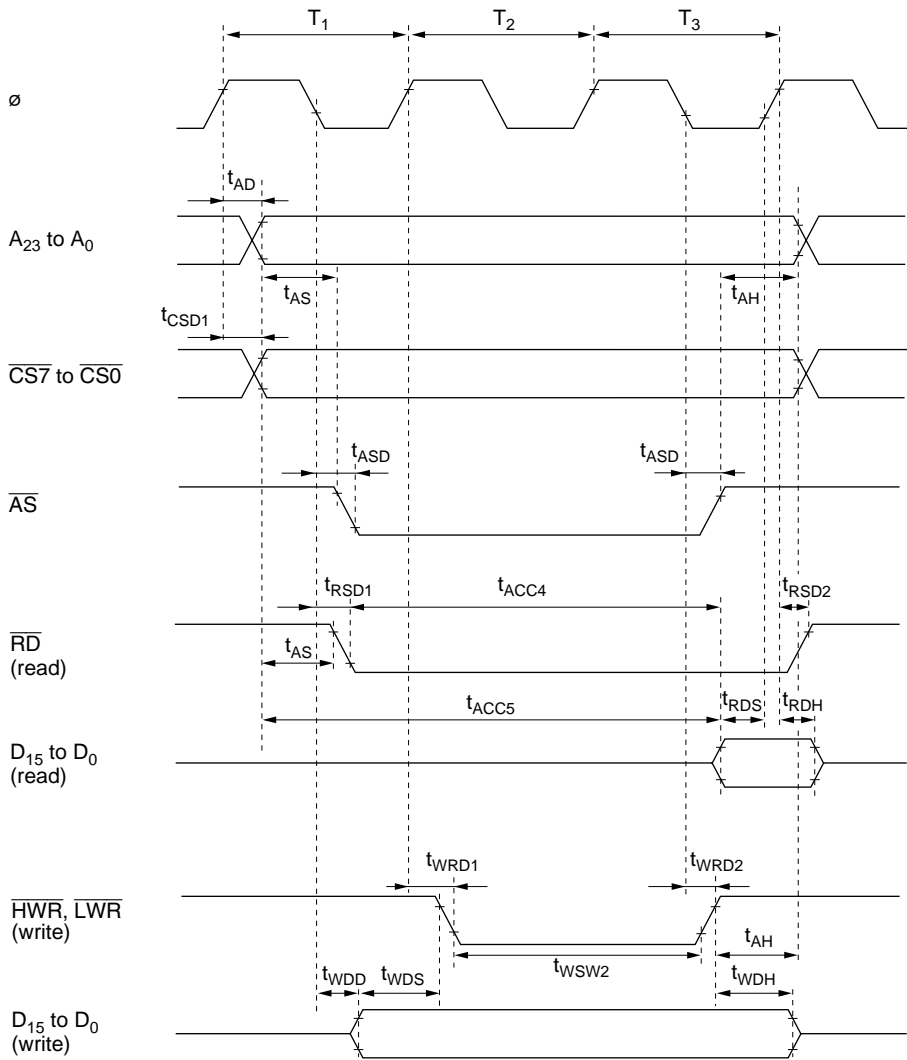

Figure 20-9 Basic Bus Timing (Three-State Access)

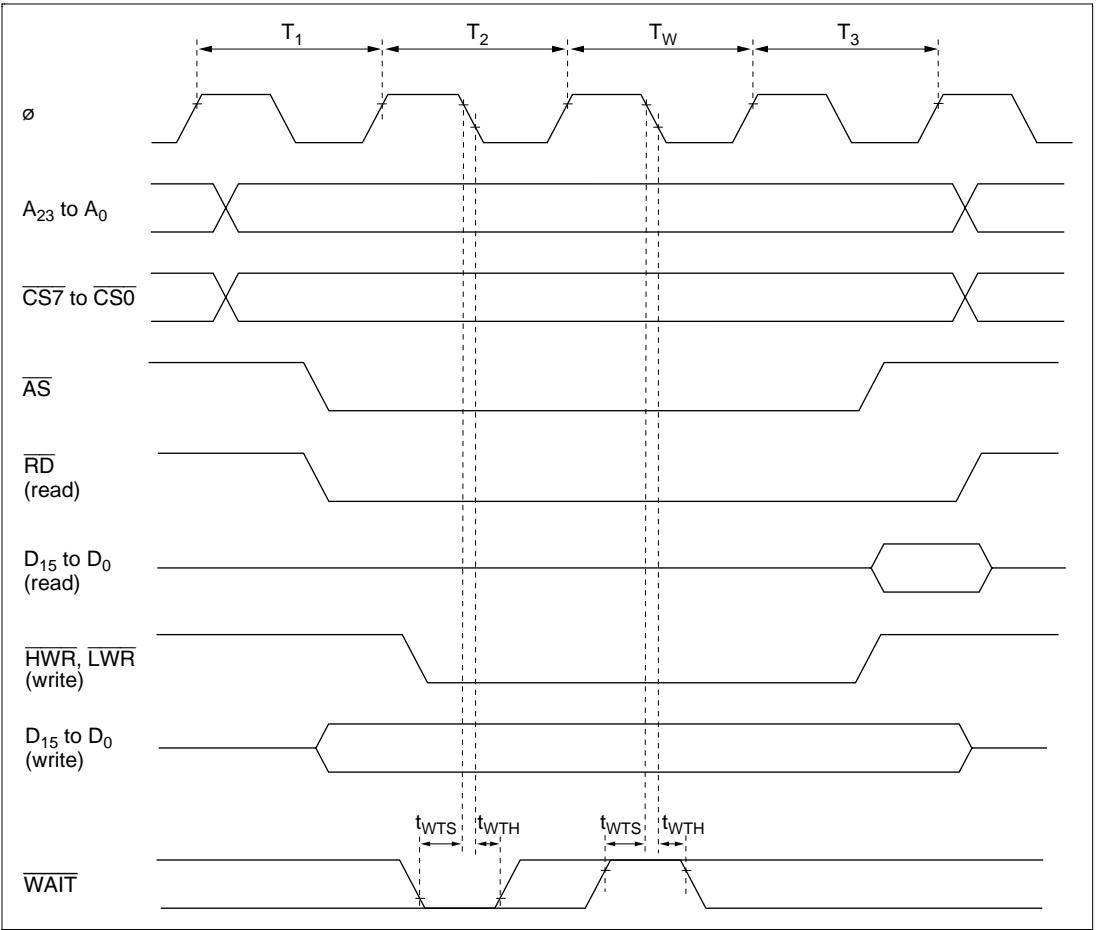

Figure 20-10 Basic Bus Timing (Three-State Access with One Wait State)

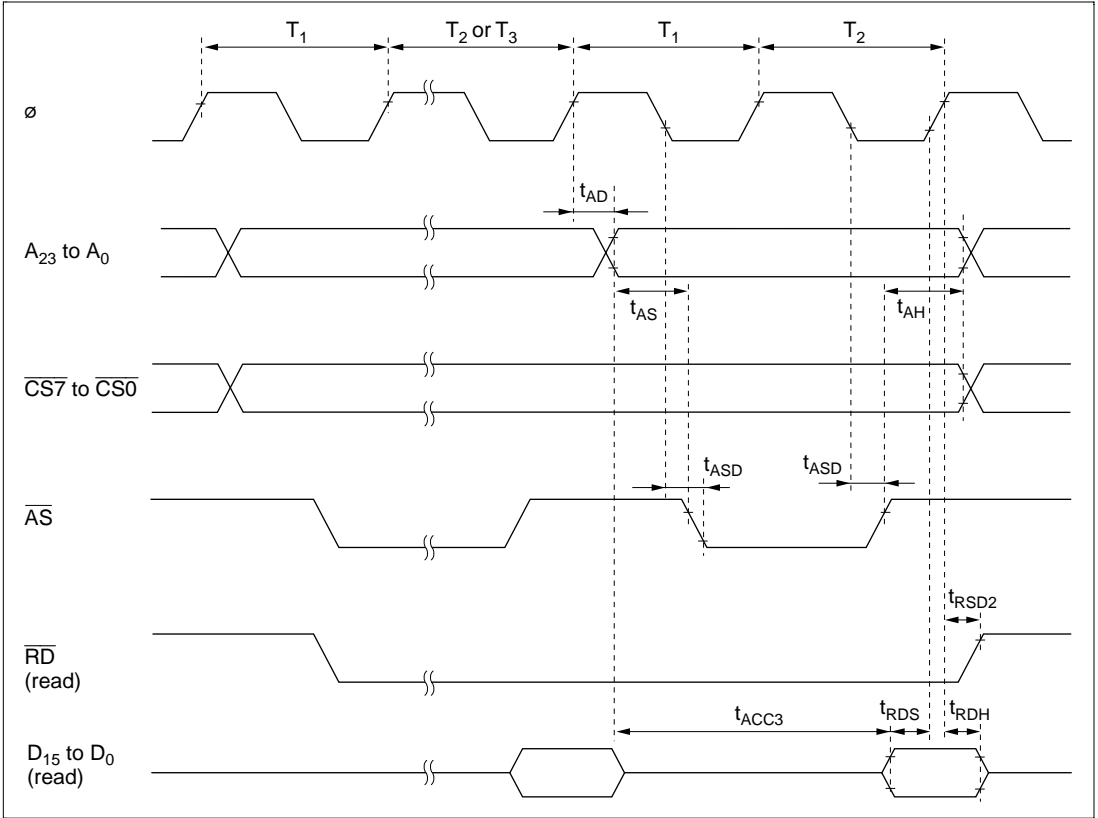

Figure 20-11 Burst ROM Access Timing (Two-State Access)

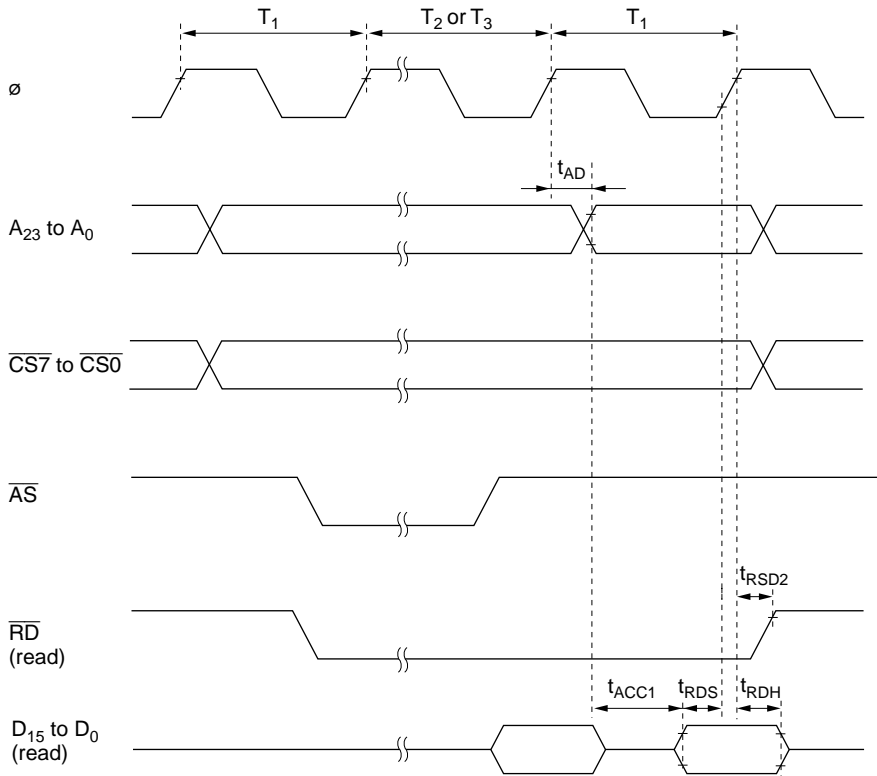

Figure 20-12 Burst ROM Access Timing (One-State Access)

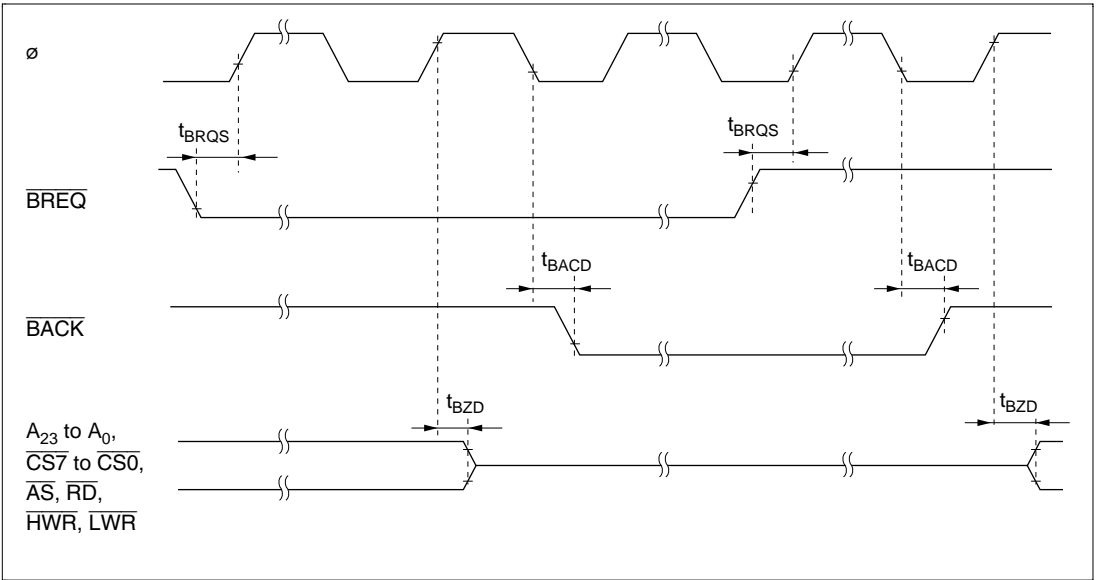

Figure 20-13 External Bus Release Timing

20.3.4 Timing of On-Chip Supporting Modules

Table 20-7 lists the timing of on-chip supporting modules.

Table 20-7 Timing of On-Chip Supporting Modules

Condition A: $V_{CC} = 2.7\text{ V to }5.5\text{ V}$, $AV_{CC} = 2.7\text{ V to }5.5\text{ V}$, $V_{ref} = 2.7\text{ V to }AV_{CC}$,
 $V_{SS} = AV_{SS} = 0\text{ V}$, $\phi = 2\text{ to }10\text{ MHz}$, $T_a = -20\text{ to }+75^\circ\text{C}$ (regular specifications),
 $T_a = -40\text{ to }+85^\circ\text{C}$ (wide-range specifications)

Condition B: $V_{CC} = 5.0\text{ V} \pm 10\%$, $AV_{CC} = 5.0\text{ V} \pm 10\%$, $V_{ref} = 4.5\text{ V to }AV_{CC}$,
 $V_{SS} = AV_{SS} = 0\text{ V}$, $\phi = 2\text{ to }20\text{ MHz}$, $T_a = -20\text{ to }+75^\circ\text{C}$ (regular specifications),
 $T_a = -40\text{ to }+85^\circ\text{C}$ (wide-range specifications)

Condition C: (mask ROM version only)
 $V_{CC} = 3.0\text{ to }5.5\text{ V}$, $AV_{CC} = 3.0\text{ to }5.5\text{ V}$, $V_{ref} = 3.0\text{ V to }AV_{CC}$,
 $V_{SS} = AV_{SS} = 0\text{ V}$, $\phi = 2\text{ to }13\text{ MHz}$, $T_a = -20\text{ to }+75^\circ\text{C}$ (regular specifications),
 $T_a = -40\text{ to }+85^\circ\text{C}$ (wide-range specifications)

Item	Symbol	Condition A		Condition B		Condition C		Unit	Test Conditions		
		Min	Max	Min	Max	Min	Max				
I/O port	Output data delay time	t_{PWD}	—	100	—	50	—	75	ns	Figure 20-14	
	Input data setup time	t_{PRS}	50	—	30	—	50	—			
	Input data hold time	t_{PRH}	50	—	30	—	50	—			
TPU	Timer output delay time	t_{TOCD}	—	100	—	50	—	75	ns	Figure 20-15	
	Timer input setup time	t_{TICS}	50	—	30	—	50	—			
	Timer clock input setup time	t_{TCKS}	50	—	30	—	50	—	ns	Figure 20-16	
	Timer clock pulse width	Single edge	t_{TCKWH}	1.5	—	1.5	—	1.5	—	t_{cyc}	
		Both edges	t_{TCKWL}	2.5	—	2.5	—	2.5	—		

Item	Symbol	Condition A		Condition B		Condition C		Unit	Test Conditions		
		Min	Max	Min	Max	Min	Max				
TMR	Timer output delay time	t_{TMOD}	—	100	—	50	—	75	ns	Figure 20-17	
	Timer reset input setup time	t_{TMRS}	50	—	30	—	50	—	ns	Figure 20-19	
	Timer clock input setup time	t_{TMCS}	50	—	30	—	50	—	ns	Figure 20-18	
	Timer clock pulse width	Single edge	t_{TMCWH}	1.5	—	1.5	—	1.5	—	t_{cyc}	Figure 20-18
Both edges		t_{TMCWL}	2.5	—	2.5	—	2.5	—			
WDT	Overflow output delay time	t_{WOVD}	—	100	—	50	—	75	ns	Figure 20-20	
SCI	Input clock cycle	Asynchronous	$t_{S_{cyc}}$	4	—	4	—	4	—	t_{cyc}	Figure 20-21
		Synchronous		6	—	6	—	6	—		
	Input clock pulse width	t_{SCKW}	0.4	0.6	0.4	0.6	0.4	0.6	$t_{S_{cyc}}$		
	Input clock rise time	t_{SCKr}	—	1.5	—	1.5	—	1.5	t_{cyc}		
	Input clock fall time	t_{SCKf}	—	1.5	—	1.5	—	1.5			
	Transmit data delay time	t_{TXD}	—	100	—	50	—	75	ns	Figure 20-22	
	Receive data setup time (synchronous)	t_{RXS}	100	—	50	—	75	—	ns		
Receive data hold time (synchronous)	t_{RXH}	100	—	50	—	75	—	ns			
A/D converter	Trigger input setup time	t_{TRGS}	50	—	30	—	50	—	ns	Figure 20-23	

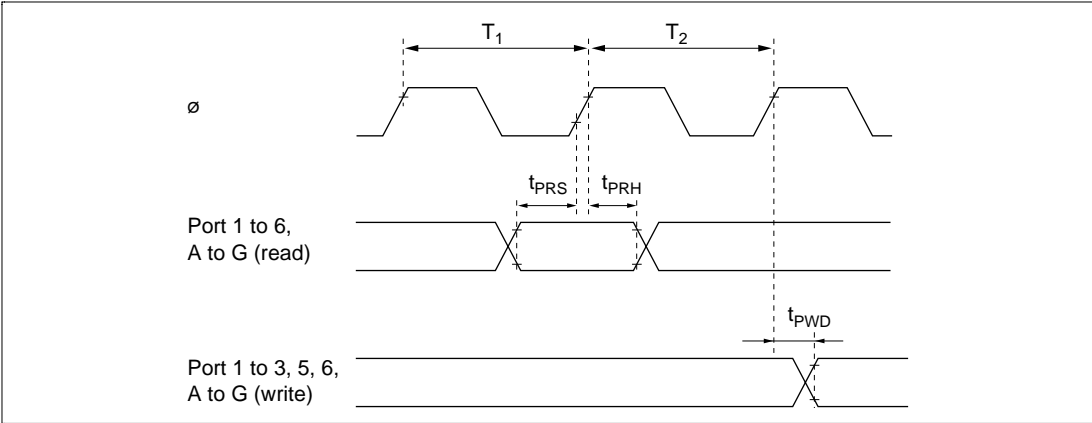

Figure 20-14 I/O Port Input/Output Timing

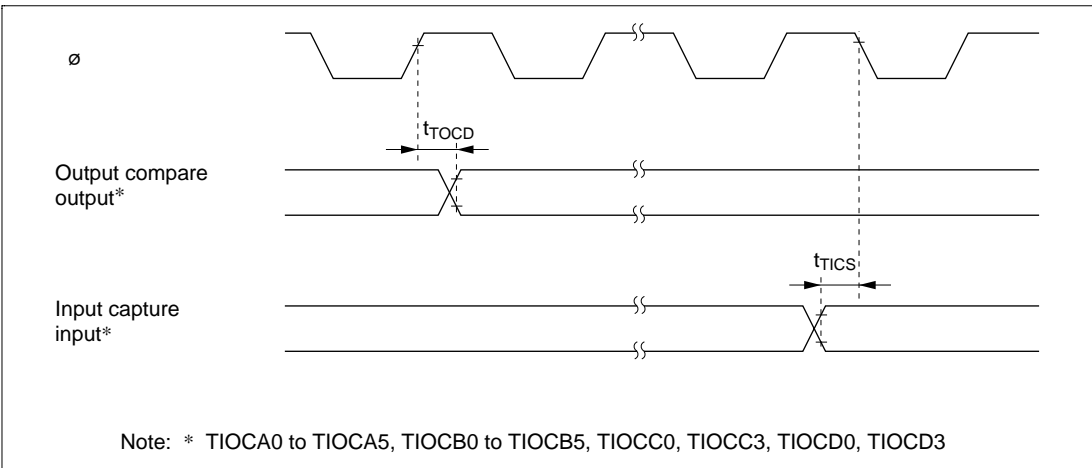

Figure 20-15 TPU Input/Output Timing

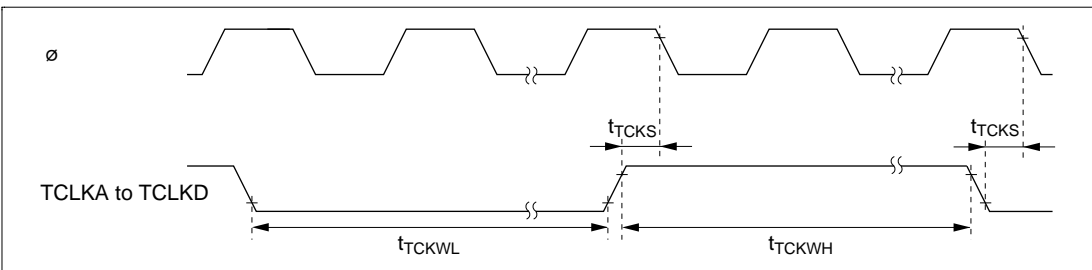

Figure 20-16 TPU Clock Input Timing

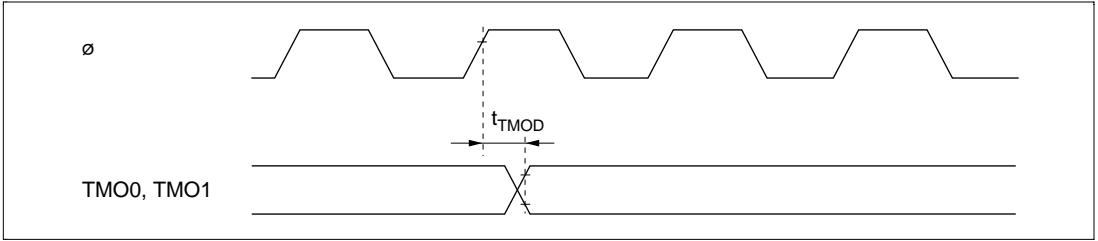

Figure 20-17 8-Bit Timer Output Timing

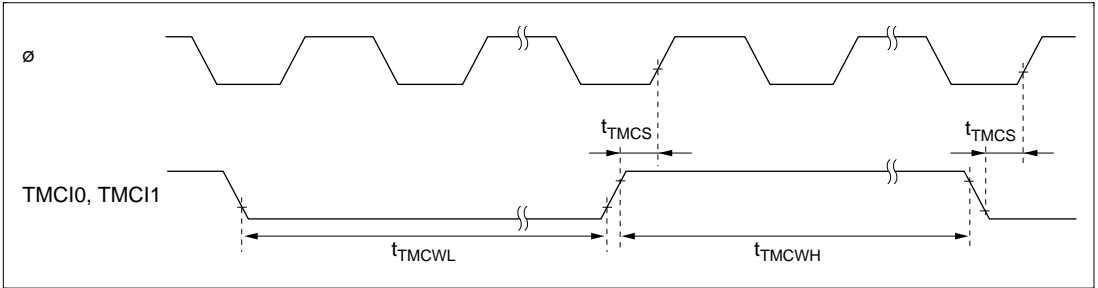

Figure 20-18 8-Bit Timer Clock Input Timing

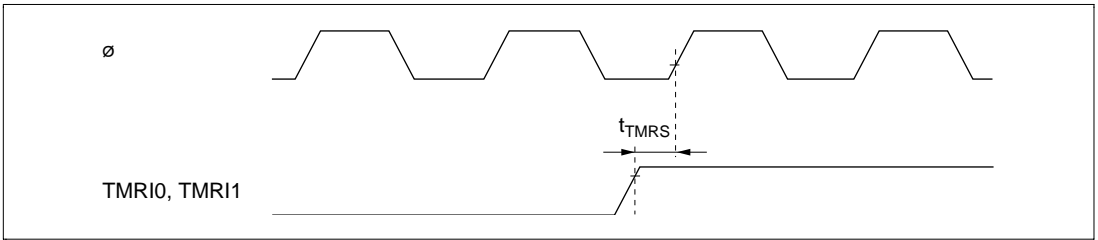

Figure 20-19 8-Bit Timer Reset Input Timing

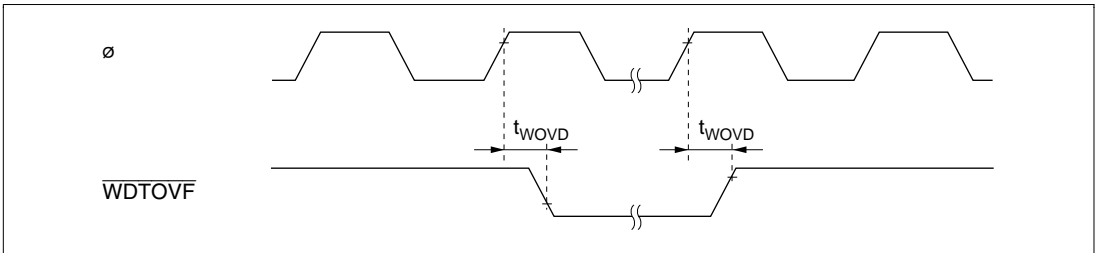

Figure 20-20 WDT Output Timing

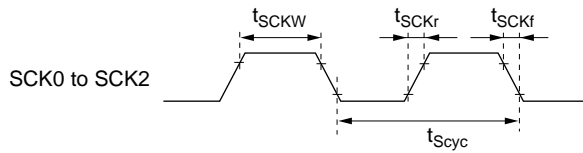

Figure 20-21 SCK Clock Input Timing

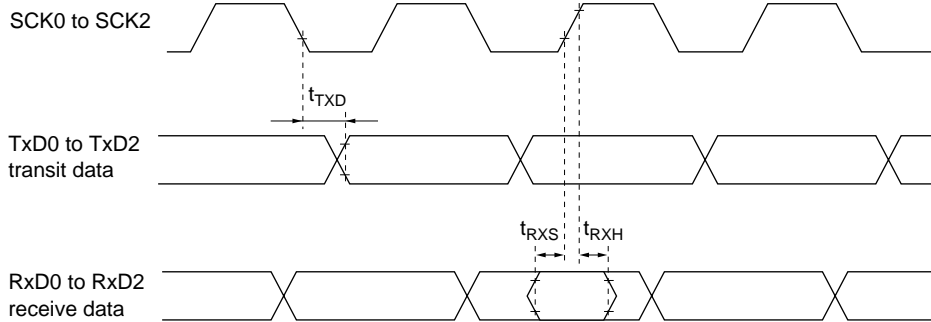

Figure 20-22 SCI Input/Output Timing (Clock Synchronous Mode)

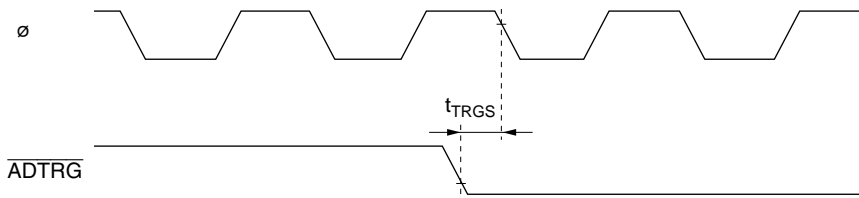

Figure 20-23 A/D Converter External Trigger Input Timing

20.4 A/D Conversion Characteristics

Table 20-8 lists the A/D conversion characteristics.

Table 20-8 A/D Conversion Characteristics

Condition A: $V_{CC} = AV_{CC} = 2.7 \text{ V to } 5.5 \text{ V}$, $V_{ref} = 2.7 \text{ V to } AV_{CC}$, $V_{SS} = AV_{SS} = 0 \text{ V}$,
 $\phi = 2 \text{ to } 10 \text{ MHz}$, $T_a = -20 \text{ to } +75^\circ\text{C}$ (regular specifications),
 $T_a = -40 \text{ to } +85^\circ\text{C}$ (wide-range specifications)

Condition B: $V_{CC} = AV_{CC} = 5.0 \text{ V} \pm 10\%$, $V_{ref} = 4.5 \text{ V to } AV_{CC}$, $V_{SS} = AV_{SS} = 0 \text{ V}$,
 $\phi = 2 \text{ to } 20 \text{ MHz}$, $T_a = -20 \text{ to } +75^\circ\text{C}$ (regular specifications),
 $T_a = -40 \text{ to } +85^\circ\text{C}$ (wide-range specifications)

Condition C: (mask ROM version only)
 $V_{CC} = AV_{CC} = 3.0 \text{ to } 5.5 \text{ V}$, $V_{ref} = 3.0 \text{ V to } AV_{CC}$, $V_{SS} = AV_{SS} = 0 \text{ V}$,
 $\phi = 2 \text{ to } 13 \text{ MHz}$, $T_a = -20 \text{ to } +75^\circ\text{C}$ (regular specifications),
 $T_a = -40 \text{ to } +85^\circ\text{C}$ (wide-range specifications)

Item	Condition A			Condition B			Condition C			Unit
	Min	Typ	Max	Min	Typ	Max	Min	Typ	Max	
Resolution	10	10	10	10	10	10	10	10	10	bits
Conversion time	—	—	13.4	—	—	6.7	—	—	10.4	μs
Analog input capacitance	—	—	20	—	—	20	—	—	20	pF
Permissible signal-source impedance	—	—	10^{*1}	—	—	10^{*3}	—	—	10^{*1}	k Ω
	—	—	5^{*2}	—	—	5^{*4}	—	—	5^{*5}	
Nonlinearity error	—	—	± 7.5	—	—	± 3.5	—	—	± 7.5	LSB
Offset error	—	—	± 7.5	—	—	± 3.5	—	—	± 7.5	LSB
Full-scale error	—	—	± 7.5	—	—	± 3.5	—	—	± 7.5	LSB
Quantization	—	—	± 0.5	—	—	± 0.5	—	—	± 0.5	LSB
Absolute accuracy	—	—	± 8.0	—	—	± 4.0	—	—	± 8.0	LSB

Notes: 1. $4.0 \text{ V} \leq AV_{CC} \leq 5.5 \text{ V}$

2. $2.7 \text{ V} \leq AV_{CC} < 4.0 \text{ V}$

3. $\phi \leq 12 \text{ MHz}$

4. $\phi > 12 \text{ MHz}$

5. $3.0 \text{ V} \leq AV_{CC} < 4.0 \text{ V}$

20.5 D/A Conversion Characteristics

Table 20-9 lists the D/A conversion characteristics.

Table 20-9 D/A Conversion Characteristics

Condition A: $V_{CC} = AV_{CC} = 2.7\text{ V to }5.5\text{ V}$, $V_{ref} = 2.7\text{ V to }AV_{CC}$, $V_{SS} = AV_{SS} = 0\text{ V}$,
 $\phi = 2\text{ to }10\text{ MHz}$, $T_a = -20\text{ to }+75^\circ\text{C}$ (regular specifications),
 $T_a = -40\text{ to }+85^\circ\text{C}$ (wide-range specifications)

Condition B: $V_{CC} = AV_{CC} = 5.0\text{ V} \pm 10\%$, $V_{ref} = 4.5\text{ V to }AV_{CC}$, $V_{SS} = AV_{SS} = 0\text{ V}$,
 $\phi = 2\text{ to }20\text{ MHz}$, $T_a = -20\text{ to }+75^\circ\text{C}$ (regular specifications),
 $T_a = -40\text{ to }+85^\circ\text{C}$ (wide-range specifications)

Condition C: (mask ROM version only)
 $V_{CC} = AV_{CC} = 3.0\text{ to }5.5\text{ V}$, $V_{ref} = 3.0\text{ V to }AV_{CC}$, $V_{SS} = AV_{SS} = 0\text{ V}$,
 $\phi = 2\text{ to }13\text{ MHz}$, $T_a = -20\text{ to }+75^\circ\text{C}$ (regular specifications),
 $T_a = -40\text{ to }+85^\circ\text{C}$ (wide-range specifications)

Item	Condition A			Condition B			Condition C			Unit	Test Conditions
	Min	Typ	Max	Min	Typ	Max	Min	Typ	Max		
Resolution	8	8	8	8	8	8	8	8	8	bit	
Conversion time	—	—	10	—	—	10	—	—	10	μs	20-pF capacitive load
Absolute accuracy	—	± 2.0	± 3.0	—	± 1.0	± 1.5	—	± 2.0	± 3.0	LSB	2-M Ω resistive load
	—	—	± 2.0	—	—	± 1.0	—	—	± 2.0	LSB	4-M Ω resistive load

20.6 Usage Note

Although both the ZTAT and mask ROM versions fully meet the electrical specifications listed in this manual, due to differences in the fabrication process, the on-chip ROM, and the layout patterns, there will be differences in the actual values of the electrical characteristics, the operating margins, the noise margins, and other aspects.

Therefore, if a system is evaluated using the ZTAT version, a similar evaluation should also be performed using the mask ROM version.

Appendix A Instruction Set

A.1 Instruction List

Operand Notation

Rd	General register (destination)* ¹
Rs	General register (source)* ¹
Rn	General register* ¹
ERn	General register (32-bit register)
MAC	Multiply-and-accumulate register (32-bit register)* ²
(EAd)	Destination operand
(EAs)	Source operand
EXR	Extended control register
CCR	Condition-code register
N	N (negative) flag in CCR
Z	Z (zero) flag in CCR
V	V (overflow) flag in CCR
C	C (carry) flag in CCR
PC	Program counter
SP	Stack pointer
#IMM	Immediate data
disp	Displacement
+	Add
-	Subtract
×	Multiply
÷	Divide
^	Logical AND
∨	Logical OR
⊕	Logical exclusive OR
→	Transfer from the operand on the left to the operand on the right, or transition from the state on the left to the state on the right
¬	Logical NOT (logical complement)
() < >	Contents of operand
:8/:16/:24/:32	8-, 16-, 24-, or 32-bit length

Notes: 1. General registers include 8-bit registers (R0H to R7H, R0L to R7L), 16-bit registers (R0 to R7, E0 to E7), and 32-bit registers (ER0 to ER7).

2. The MAC register cannot be used in the H8S/2355 Series.

Condition Code Notation

Symbol

↑	Changes according to the result of instruction
*	Undetermined (no guaranteed value)
0	Always cleared to 0
1	Always set to 1
—	Not affected by execution of the instruction

Table A-1 Instruction Set

(1) Data Transfer Instructions

Mnemonic	Operand Size	Addressing Mode/ Instruction Length (Bytes)						Operation	Condition Code						No. of States*1	
		#xx	Rn	@ERN	@(d,ERN)	@-RN/@ERN+	@aa		@(d,PC)	@aa	I	H	N	Z		V
MOV	B	2						#xx:8→Rd8	—	—	↑	↑	0	—	—	1
	B	2						Rs8→Rd8	—	—	↑	↑	0	—	—	1
	B	2						@ERs→Rd8	—	—	↑	↑	0	—	—	2
	B	4						@(d:16,ERs)→Rd8	—	—	↑	↑	0	—	—	3
	B	8						@(d:32,ERs)→Rd8	—	—	↑	↑	0	—	—	5
	B	2						@ERs→Rd8,ERs32+1→ERs32	—	—	↑	↑	0	—	—	3
	B	2						@aa:8→Rd8	—	—	↑	↑	0	—	—	2
	B	4						@aa:16→Rd8	—	—	↑	↑	0	—	—	3
	B	6						@aa:32→Rd8	—	—	↑	↑	0	—	—	4
	B	2						Rs8→@ERd	—	—	↑	↑	0	—	—	2
	B	4						Rs8→@(d:16,ERd)	—	—	↑	↑	0	—	—	3
	B	8						Rs8→@(d:32,ERd)	—	—	↑	↑	0	—	—	5
	B	2						ERd32-1→ERd32,Rs8→@ERd	—	—	↑	↑	0	—	—	3
	B	2						Rs8→@aa:8	—	—	↑	↑	0	—	—	2
	B	4						Rs8→@aa:16	—	—	↑	↑	0	—	—	3
	B	6						Rs8→@aa:32	—	—	↑	↑	0	—	—	4
	W	4						#xx:16→Rd16	—	—	↑	↑	0	—	—	2
	W	2						Rs16→Rd16	—	—	↑	↑	0	—	—	1
	W	2						@ERs→Rd16	—	—	↑	↑	0	—	—	2

Mnemonic	Operand Size	Addressing Mode/ Instruction Length (Bytes)							Operation	Condition Code						No. of States*1		
		#xx	Rn	@ERn	@ (d,ERn)	@-ERn/@ERn+	@aa	@ (d,PC)		@aa	I	H	N	Z	V	C	Normal	Advanced
MOV	W								@(d:16,ERs)→Rd16	—	↕	↕	0	—	3			
	W								@(d:32,ERs)→Rd16	—	↕	↕	0	—	5			
	W								@ERs→Rd16,ERs32+2→ERs32	—	↕	↕	0	—	3			
	W							4	@aa:16→Rd16	—	↕	↕	0	—	3			
	W							6	@aa:32→Rd16	—	↕	↕	0	—	4			
	W							2	Rst16→@ERd	—	↕	↕	0	—	2			
	W							4	Rst16→@(d:16,ERd)	—	↕	↕	0	—	3			
	W							8	Rst16→@(d:32,ERd)	—	↕	↕	0	—	5			
	W							2	ERd32-2→ERd32,Rst16→@ERd	—	↕	↕	0	—	3			
	W							4	Rst16→@aa:16	—	↕	↕	0	—	3			
	W							6	Rst16→@aa:32	—	↕	↕	0	—	4			
	L	6							#xx:32→ERd32	—	↕	↕	0	—	3			
	L	2							ERs32→ERd32	—	↕	↕	0	—	1			
	L								@ERs→ERd32	—	↕	↕	0	—	4			
	L								@(d:16,ERs)→ERd32	—	↕	↕	0	—	5			
	L							10	@(d:32,ERs)→ERd32	—	↕	↕	0	—	7			
	L							4	@ERs→ERd32,ERs32+4→ERs32	—	↕	↕	0	—	5			
	L							6	@aa:16→ERd32	—	↕	↕	0	—	5			
	L							8	@aa:32→ERd32	—	↕	↕	0	—	6			

	Mnemonic	Operand Size	Addressing Mode/ Instruction Length (Bytes)							Operation	Condition Code							No. of States*1	
			#xx	F ₁	@ERn	@(d,ERn)	@-ERn/@ERn+	@aa	@(d,PC)		@aa	I	H	N	Z	V	C	Normal	Advanced
MOV	MOV.L ERs,@ERd	L		4						ERS32→@ERd	—	—	↑	↑	0	—	4		
	MOV.L ERs,@(d:16,ERd)	L			6					ERS32→@(d:16,ERd)	—	—	↑	↑	0	—	5		
	MOV.L ERs,@(d:32,ERd)	L			10					ERS32→@(d:32,ERd)	—	—	↑	↑	0	—	7		
	MOV.L ERs,@-ERd	L			4					ERd32-4→ERd32,ERS32→@ERd	—	—	↑	↑	0	—	5		
	MOV.L ERs,@aa:16	L			6					ERS32→@aa:16	—	—	↑	↑	0	—	5		
	MOV.L ERs,@aa:32	L			8					ERS32→@aa:32	—	—	↑	↑	0	—	6		
POP	POP.W Rn	W							2	@SP→Rn16,SP+2→SP	—	—	↑	↑	0	—	3		
	POP.L ERn	L							4	@SP→ERn32,SP+4→SP	—	—	↑	↑	0	—	5		
PUSH	PUSH.W Rn	W							2	SP-2→SP,Rn16→@SP	—	—	↑	↑	0	—	3		
	PUSH.L ERn	L							4	SP-4→SP,ERn32→@SP	—	—	↑	↑	0	—	5		
LDM	LDM @SP+,(ERm-ERn)	L							4	(@SP→ERn32,SP+4→SP) Repeated for each register restored	—	—	—	—	—	—	7/9/11 [1]		
STM	STM (ERm-ERn),@-SP	L							4	(SP-4→SP,ERn32→@SP) Repeated for each register saved	—	—	—	—	—	—	7/9/11 [1]		
MOVFP	MOVFP @aa:16,Rd									Cannot be used in the H8S/2355 Series							[2]		
MOVTP	MOVTP ERs,@aa:16									Cannot be used in the H8S/2355 Series							[2]		

(3) Logical Instructions

Mnemonic	Operand Size	Addressing Mode/ Instruction Length (Bytes)						Operation	Condition Code							No. of States*1			
		#X	Rn	@ERn	@d,ERn	@-ERn/@ERn+	@aa		@d,PC	@aa	I	H	N	Z	V	C	Normal	Advanced	
																			1
AND	AND.B #xx:8,Rd	B	2															1	
	AND.B Rs,Rd	B	2																1
	AND.W #xx:16,Rd	W	4																2
	AND.W Rs,Rd	W	2																1
	AND.L #xx:32,ERd	L	6																3
	AND.L ERs,ERd	L	4																2
OR	OR.B #xx:8,Rd	B	2																1
	OR.B Rs,Rd	B	2																1
	OR.W #xx:16,Rd	W	4																2
	OR.W Rs,Rd	W	2																1
	OR.L #xx:32,ERd	L	6																3
	OR.L ERs,ERd	L	4																2
XOR	XOR.B #xx:8,Rd	B	2																1
	XOR.B Rs,Rd	B	2																1
	XOR.W #xx:16,Rd	W	4																2
	XOR.W Rs,Rd	W	2																1
	XOR.L #xx:32,ERd	L	6																3
	XOR.L ERs,ERd	L	4																2
NOT	NOT.B Rd	B	2																1
	NOT.W Rd	W	2																1
	NOT.L ERd	L	2																1

(4) Shift Instructions

Mnemonic	Operand Size	Addressing Mode/ Instruction Length (Bytes)							Operation	Condition Code							No. of States*1	
		#xx	Rn	@(d,ERn)	@-ERn/@ERn+	@aa	@(d,PC)	@aa		I	H	N	Z	V	C	Normal	Advanced	
										—	—	—	—	—	—	—	—	
SHAL	B	2								←	←	←	←	←	←	1		
	B	2								←	←	←	←	←	←	1		
	W	2								←	←	←	←	←	←	1		
	W	2								←	←	←	←	←	←	1		
	L	2								←	←	←	←	←	←	1		
	L	2								←	←	←	←	←	←	1		
SHAR	B	2								←	←	←	←	←	←	1		
	B	2								←	←	←	←	←	←	1		
	W	2								←	←	←	←	←	←	1		
	W	2								←	←	←	←	←	←	1		
	L	2								←	←	←	←	←	←	1		
	L	2								←	←	←	←	←	←	1		
SHLL	B	2								←	←	←	←	←	←	1		
	B	2								←	←	←	←	←	←	1		
	W	2								←	←	←	←	←	←	1		
	W	2								←	←	←	←	←	←	1		
	L	2								←	←	←	←	←	←	1		
	L	2								←	←	←	←	←	←	1		

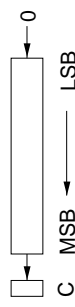
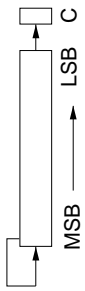
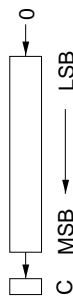

Mnemonic	Operand Size	Addressing Mode/ Instruction Length (Bytes)							Operation	Condition Code							No. of States ^{*1}	
		#xx	Rn	@ERn	@ (d,ERn)	@-ERn/@ERn+	@aa	@ (d,PC)		@@aa	I	H	N	Z	V	C	Normal	Advanced
SHLR	B	2									0	↕	0	↕	1	1		
	B	2									0	↕	0	↕	1	1		
	W	2									0	↕	0	↕	1	1		
	W	2									0	↕	0	↕	1	1		
	L	2									0	↕	0	↕	1	1		
	L	2									0	↕	0	↕	1	1		
ROTXL	B	2									↕	↕	0	↕	1	1		
	B	2									↕	↕	0	↕	1	1		
	W	2									↕	↕	0	↕	1	1		
	W	2									↕	↕	0	↕	1	1		
	L	2									↕	↕	0	↕	1	1		
	L	2									↕	↕	0	↕	1	1		
ROTXR	B	2									↕	↕	0	↕	1	1		
	B	2									↕	↕	0	↕	1	1		
	W	2									↕	↕	0	↕	1	1		
	W	2									↕	↕	0	↕	1	1		
	L	2									↕	↕	0	↕	1	1		
	L	2									↕	↕	0	↕	1	1		

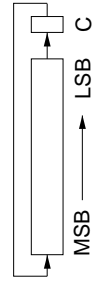

Mnemonic	Operand Size	Addressing Mode/ Instruction Length (Bytes)							Operation	Condition Code							No. of States*1	
		#xx	Rn	@ERn	@ (d,ERn)	@-ERn/@ERn+	@aa	@ (d,PC)		@aa	I	H	N	Z	V	C	Normal	Advanced
ROTL	ROTL.B Rd	2															1	
	ROTL.B #2,Rd	2															1	
	ROTL.W Rd	2															1	
	ROTL.W #2,Rd	2															1	
	ROTL.L ERd	2															1	
	ROTL.L #2,ERd	2															1	
ROTR	ROTR.B Rd	2															1	
	ROTR.B #2,Rd	2															1	
	ROTR.W Rd	2															1	
	ROTR.W #2,Rd	2															1	
	ROTR.L ERd	2															1	
	ROTR.L #2,ERd	2															1	

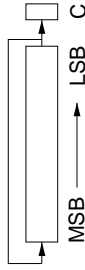

(5) Bit-Manipulation Instructions

Mnemonic	Operand Size						Addressing Mode/ Instruction Length (Bytes)						Condition Code						No. of States*1				
	#xx	Rn	@ERn	@ (d,ERn)	@-ERn/@ERn+	@aa	@ (d,PC)	@aa		Operation						I	H	N	Z	V	C	Normal	Advanced
										Operation													
BSET	B	2																				1	
	B	4																				4	
	B		4																			4	
	B			6																			5
	B			8																			6
	B	2																					1
	B		4																				4
	B			4																			4
BCLR	B			6																			5
	B			8																			6
	B	2																					1
	B		4																				4
	B			4																			4
	B			6																			5
	B			8																			6
	B	2																					1
	B		4																				4
	B			4																			4
	B			6																			5

Mnemonic	Operand Size	Addressing Mode/ Instruction Length (Bytes)							Operation	Condition Code					No. of States*1			
		#xx	F ₅	@ERn	@(d,ERn)	@-ERn/@ERn+	@aa	@(d,PC)			I	H	N	Z	V	C	Normal	Advanced
BCLR	B					8			(Rn8 of @aa:32)←0	—	—	—	—	—	—	6		
BNOT	B	2							(#xx:3 of Rd8)←[¬ (#xx:3 of Rd8)]	—	—	—	—	—	—	1		
	B	4							(#xx:3 of @ERd)← [¬ (#xx:3 of @ERd)]	—	—	—	—	—	—	4		
	B		4						(#xx:3 of @aa:8)← [¬ (#xx:3 of @aa:8)]	—	—	—	—	—	—	4		
	B		6						(#xx:3 of @aa:16)← [¬ (#xx:3 of @aa:16)]	—	—	—	—	—	—	5		
BNOT	B		8						(#xx:3 of @aa:32)← [¬ (#xx:3 of @aa:32)]	—	—	—	—	—	—	6		
	B	2							(Rn8 of Rd8)←[¬ (Rn8 of Rd8)]	—	—	—	—	—	—	1		
	B		4						(Rn8 of @ERd)←[¬ (Rn8 of @ERd)]	—	—	—	—	—	—	4		
	B		4						(Rn8 of @aa:8)←[¬ (Rn8 of @aa:8)]	—	—	—	—	—	—	4		
BNOT	B		6						(Rn8 of @aa:16)← [¬ (Rn8 of @aa:16)]	—	—	—	—	—	—	5		
	B		8						(Rn8 of @aa:32)← [¬ (Rn8 of @aa:32)]	—	—	—	—	—	—	6		
	B		2						(Rn8 of @aa:32)← [¬ (Rn8 of @aa:32)]	—	—	—	—	—	—	6		
	B		2						(#xx:3 of Rd8)→Z	—	—	—	—	—	—	1		
BTST	B	2							(#xx:3 of @ERd)→Z	—	—	—	—	—	—	3		
	B		4						(#xx:3 of @aa:8)→Z	—	—	—	—	—	—	3		
	B		4						(#xx:3 of @aa:16)→Z	—	—	—	—	—	—	3		
	B		6						(#xx:3 of @aa:32)→Z	—	—	—	—	—	—	4		

Mnemonic	Operand Size	Addressing Mode/ Instruction Length (Bytes)						Operation	Condition Code						No. of States*1				
		#xx	Rn	@ERn	@ERn	@ERn+ @ERn	@ERn+ @ERn		@aa	@aa @aa	@aa @aa	I	H	N	Z	V	C	Normal	Advanced
BST	B						6	C→(#xx:3 of @aa:16)	—	—	—	—	—	—	—	—	5		
	B						8	C→(#xx:3 of @aa:32)	—	—	—	—	—	—	—	—	6		
BIST	B	2						¬ C→(#xx:3 of Rd8)	—	—	—	—	—	—	—	1			
	B		4					¬ C→(#xx:3 of @ERd)	—	—	—	—	—	—	—	4			
	B			4				¬ C→(#xx:3 of @aa:8)	—	—	—	—	—	—	—	4			
	B				6			¬ C→(#xx:3 of @aa:16)	—	—	—	—	—	—	—	5			
BAND	B						8	¬ C→(#xx:3 of @aa:32)	—	—	—	—	—	—	—	6			
	B	2						C^(#xx:3 of Rd8)→C	—	—	—	—	—	↑	—	1			
	B		4					C^(#xx:3 of @ERd)→C	—	—	—	—	—	↑	—	3			
	B			4				C^(#xx:3 of @aa:8)→C	—	—	—	—	—	↑	—	3			
	B				6			C^(#xx:3 of @aa:16)→C	—	—	—	—	—	↑	—	4			
	B					8		C^(#xx:3 of @aa:32)→C	—	—	—	—	—	↑	—	5			
BIAND	B	2						C^[- (#xx:3 of Rd8)]→C	—	—	—	—	—	↑	—	1			
	B		4					C^[- (#xx:3 of @ERd)]→C	—	—	—	—	—	↑	—	3			
BIAND	B			4				C^[- (#xx:3 of @aa:8)]→C	—	—	—	—	—	↑	—	3			
	B				6			C^[- (#xx:3 of @aa:16)]→C	—	—	—	—	—	↑	—	4			
	B					8		C^[- (#xx:3 of @aa:32)]→C	—	—	—	—	—	↑	—	5			
	B	2						Cv(#xx:3 of Rd8)→C	—	—	—	—	—	↑	—	1			
BOR	B		4					Cv(#xx:3 of @ERd)→C	—	—	—	—	—	↑	—	3			

(6) Branch Instructions

Mnemonic	Operand Size	Addressing Mode/ Instruction Length (Bytes)							Operation	Branching Condition	Condition Code							No. of States*1		
		#xx	Rn	@ERN	@(d,ERn)	@-ERn/@ERn+	@aa	@(d,PC) @aa			I	H	N	Z	V	C	Normal	Advanced		
Bcc	—	—	—	—	—	—	2	2	if condition is true then	Always	—	—	—	—	—	—	2			
BRA d:8(BT d:8)	—	—	—	—	—	—	4	4	PC←PC+d	Never	—	—	—	—	—	—	3			
BRA d:16(BT d:16)	—	—	—	—	—	—	2	2	else next;	Never	—	—	—	—	—	—	2			
BRN d:8(BF d:8)	—	—	—	—	—	—	4	4		Never	—	—	—	—	—	—	3			
BRN d:16(BF d:16)	—	—	—	—	—	—	2	2		C∨Z=0	—	—	—	—	—	—	2			
BHI d:8	—	—	—	—	—	—	4	4		C∨Z=1	—	—	—	—	—	—	3			
BHI d:16	—	—	—	—	—	—	2	2		C∨Z=1	—	—	—	—	—	—	2			
BLS d:8	—	—	—	—	—	—	4	4		C=0	—	—	—	—	—	—	3			
BLS d:16	—	—	—	—	—	—	2	2		C=0	—	—	—	—	—	—	2			
BCC d:B(BHS d:8)	—	—	—	—	—	—	4	4		C=1	—	—	—	—	—	—	3			
BCC d:16(BHS d:16)	—	—	—	—	—	—	2	2		C=1	—	—	—	—	—	—	2			
BCS d:8(BLO d:8)	—	—	—	—	—	—	4	4		Z=0	—	—	—	—	—	—	3			
BCS d:16(BLO d:16)	—	—	—	—	—	—	2	2		Z=0	—	—	—	—	—	—	2			
BNE d:8	—	—	—	—	—	—	4	4		Z=1	—	—	—	—	—	—	3			
BNE d:16	—	—	—	—	—	—	2	2		Z=1	—	—	—	—	—	—	2			
BEQ d:8	—	—	—	—	—	—	4	4		V=0	—	—	—	—	—	—	3			
BEQ d:16	—	—	—	—	—	—	2	2		V=0	—	—	—	—	—	—	2			
BVC d:8	—	—	—	—	—	—	4	4		V=0	—	—	—	—	—	—	3			
BVC d:16	—	—	—	—	—	—	2	2		V=0	—	—	—	—	—	—	2			

Mnemonic	Operand Size	Addressing Mode/ Instruction Length (Bytes)								Operation	Condition Code						No. of States ^{*1}	
		#xx	Rn	@ERn	@(d,ERn)	@-ERn/@ERn+	@aa	@(d,PC)	@aa		I	H	N	Z	V	C	Normal	Advanced
Bcc	—							2			V=1	—	—	—	—	—	2	
BVS d:8	—							4			N=0	—	—	—	—	—	3	
BPL d:8	—							2				—	—	—	—	—	2	
BPL d:16	—							4				—	—	—	—	—	3	
BMI d:8	—							2			N=1	—	—	—	—	—	2	
BMI d:16	—							4				—	—	—	—	—	3	
BGE d:8	—							2			N \oplus V=0	—	—	—	—	—	2	
BGE d:16	—							4				—	—	—	—	—	3	
BLT d:8	—							2			N \oplus V=1	—	—	—	—	—	2	
BLT d:16	—							4				—	—	—	—	—	3	
BGT d:8	—							2			Z \vee (N \oplus V)=0	—	—	—	—	—	2	
BGT d:16	—							4				—	—	—	—	—	3	
BLE d:8	—							2			Z \vee (N \oplus V)=1	—	—	—	—	—	2	
BLE d:16	—							4				—	—	—	—	—	3	

Mnemonic	Operand Size	Addressing Mode/ Instruction Length (Bytes)							Operation	Condition Code						No. of States*1		
		#xxx	Rn	@ERn	@ (d,ERn)	@-ERn/@ERn+	@aa	@ (d,PC)		@aa	I	H	N	Z	V	C	Normal	Advanced
JMP	—		2						PC←ERn	—	—	—	—	—	—	2		
	—					4			PC←aa:24	—	—	—	—	—	—	3		
	—							2	PC←@aa:8	—	—	—	—	—	—	4	5	
BSR	—							2	PC→@-SP,PC←PC+d:8	—	—	—	—	—	—	3	4	
	—							4	PC→@-SP,PC←PC+d:16	—	—	—	—	—	—	4	5	
JSR	—		2						PC→@-SP,PC←ERn	—	—	—	—	—	—	3	4	
	—							4	PC→@-SP,PC←aa:24	—	—	—	—	—	—	4	5	
	—							2	PC→@-SP,PC←@aa:8	—	—	—	—	—	—	4	6	
RTS	—								PC←@SP+	—	—	—	—	—	—	4	5	

(7) System Control Instructions

Mnemonic	Operand Size	Addressing Mode/ Instruction Length (Bytes)								Operation	Condition Code					No. of States*1		
		#xx	@ERN	@(d,ERn)	@-ERn/@ERN+	@aa	@(d,PC)	@	@aa		I	H	N	Z	V	C	Normal	Advanced
TRAPA	—										PC→@-SP,CCR→@-SP, EXR→@-SP,<vector>→PC	1	—	—	—	—	7 [9]	8 [9]
RTE	—										EXR←@SP+,CCR←@SP+, PC←@SP+	↕	↕	↕	↕	↕	5 [9]	
SLEEP	—										Transition to power-down state	—	—	—	—	—		2
LDC	B 2										#xx:8→CCR	↕	↕	↕	↕	↕	1	
	B 4										#xx:8→EXR	—	—	—	—	—	2	
	B 2										Rs8→CCR	↕	↕	↕	↕	↕	1	
	B 2										Rs8→EXR	—	—	—	—	—	1	
	W 4										@ERs→CCR	↕	↕	↕	↕	↕	3	
	W 4										@ERs→EXR	—	—	—	—	—	3	
	W 6										@(d:16,ERs)→CCR	↕	↕	↕	↕	↕	4	
	W 6										@(d:16,ERs)→EXR	—	—	—	—	—	4	
	W 10										@(d:32,ERs)→CCR	↕	↕	↕	↕	↕	6	
	W 10										@(d:32,ERs)→EXR	—	—	—	—	—	6	
	W 4										@ERs→CCR,ERs32+2→ERs32	↕	↕	↕	↕	↕	4	
	W 4										@ERs→EXR,ERs32+2→ERs32	—	—	—	—	—	4	
	W 6										@aa:16→CCR	↕	↕	↕	↕	↕	4	
	W 6										@aa:16→EXR	—	—	—	—	—	4	
	W 8										@aa:32→CCR	↕	↕	↕	↕	↕	5	
	W 8										@aa:32→EXR	—	—	—	—	—	5	

Mnemonic	Operand Size	Addressing Mode/ Instruction Length (Bytes)						Operation	Condition Code					No. of States*1				
		#xx	Rn	@ERn	@(d,ERn)	@-ERn/@ERn+	@aa		@(d,PC)		I	H	N	Z	V	C	Normal	Advanced
STC	STC CCR,Rd	B	2						CCR→Rd8	—	—	—	—	—	—	1		
	STC EXR,Rd	B	2						EXR→Rd8	—	—	—	—	—	—	1		
	STC CCR,@ERd	W	4						CCR→@ERd	—	—	—	—	—	—	3		
	STC EXR,@ERd	W	4						EXR→@ERd	—	—	—	—	—	—	3		
	STC CCR,@(d:16,ERd)	W		6					CCR→@(d:16,ERd)	—	—	—	—	—	—	4		
	STC EXR,@(d:16,ERd)	W		6					EXR→@(d:16,ERd)	—	—	—	—	—	—	4		
	STC CCR,@(d:32,ERd)	W		10					CCR→@(d:32,ERd)	—	—	—	—	—	—	6		
	STC EXR,@(d:32,ERd)	W		10					EXR→@(d:32,ERd)	—	—	—	—	—	—	6		
	STC CCR,@-ERd	W			4				ERd32-2→ERd32,CCR→@ERd	—	—	—	—	—	—	4		
	STC EXR,@-ERd	W			4				ERd32-2→ERd32,EXR→@ERd	—	—	—	—	—	—	4		
ANDC	ANDC CCR,@aa:16	W		6					CCR→@aa:16	—	—	—	—	—	—	4		
	ANDC EXR,@aa:16	W		6					EXR→@aa:16	—	—	—	—	—	—	4		
	ANDC CCR,@aa:32	W		8					CCR→@aa:32	—	—	—	—	—	—	5		
	ANDC EXR,@aa:32	W		8					EXR→@aa:32	—	—	—	—	—	—	5		
ORC	ORC #xx:8,CCR	B	2						CCR^#xx:8→CCR	↑	↑	↑	↑	↑	↑	1		
	ORC #xx:8,EXR	B	4						EXR^#xx:8→EXR	—	—	—	—	—	—	2		
XORC	ORC #xx:8,CCR	B	2						CCRv#xx:8→CCR	↑	↑	↑	↑	↑	↑	1		
	ORC #xx:8,EXR	B	4						EXRv#xx:8→EXR	—	—	—	—	—	—	2		
NOP	XORC #xx:8,CCR	B	2						CCR⊕#xx:8→CCR	↑	↑	↑	↑	↑	↑	1		
	XORC #xx:8,EXR	B	4						EXR⊕#xx:8→EXR	—	—	—	—	—	—	2		
NOP	NOP	—							PC←PC+2	—	—	—	—	—	—	1		

(8) Block Transfer Instructions

Mnemonic	Operand Size	Addressing Mode/ Instruction Length (Bytes)							Operation	Condition Code				No. of States*1		
		#xx	@ERn	@(d,ERn)	@-ERn/@ERn+	@aa	@(d,PC)	@aa		I	H	N	Z	V	C	Normal
EEPMOV	—							4	if R4L≠0 Repeat @ER5→@ER6 ER5+1→ER5 ER6+1→ER6 R4L-1→R4L Until R4L=0 else next;	—	—	—	—	—	—	4+2h *2
EEPMOV.W	—							4	if R4≠0 Repeat @ER5→@ER6 ER5+1→ER5 ER6+1→ER6 R4-1→R4 Until R4=0 else next;	—	—	—	—	—	—	4+2h *2

Notes: 1. The number of states is the number of states required for execution when the instruction and its operands are located in on-chip memory.
2. n is the initial value of R4L or R4.

[1] Seven states for saving or restoring two registers, nine states for three registers, or eleven states for four registers.
[2] Cannot be used in the H8S/2355 Series.

[3] Set to 1 when a carry or borrow occurs at bit 11; otherwise cleared to 0.

[4] Set to 1 when a carry or borrow occurs at bit 27; otherwise cleared to 0.

[5] Retains its previous value when the result is zero; otherwise cleared to 0.

[6] Set to 1 when the divisor is negative; otherwise cleared to 0.

[7] Set to 1 when the divisor is zero; otherwise cleared to 0.

[8] Set to 1 when the quotient is negative; otherwise cleared to 0.

[9] One additional state is required for execution when EXR is valid.

A.2 Instruction Codes

Table A-2 shows the instruction codes.

Table A-2 Instruction Codes

Instruction	Mnemonic	Size	Instruction Format																	
			1st byte	2nd byte	3rd byte	4th byte	5th byte	6th byte	7th byte	8th byte	9th byte	10th byte								
ADD	ADD.B #xx:8,Rd	B	8	rd	IMM															
	ADD.B Rs,Rd	B	0	8	rs	rd														
	ADD.W #xx:16,Rd	W	7	9	1	rd	IMM													
	ADD.W Rs,Rd	W	0	9	rs	rd														
	ADD.L #xx:32,ERd	L	7	A	1	0:erd		IMM												
ADDS	ADD.L ERs,ERd	L	0	A	1:ers	0:erd														
	ADDS #1,ERd	L	0	B	0	0:erd														
	ADDS #2,ERd	L	0	B	8	0:erd														
	ADDS #4,ERd	L	0	B	9	0:erd														
	ADDX #xx:8,Rd	B	9	rd	IMM															
AND	ADDX Rs,Rd	B	0	E	rs	rd														
	AND.B #xx:8,Rd	B	E	rd	IMM															
	AND.B Rs,Rd	B	1	6	rs	rd														
	AND.W #xx:16,Rd	W	7	9	6	rd	IMM													
	AND.W Rs,Rd	W	6	6	rs	rd														
ANDC	AND.L #xx:32,ERd	L	7	A	6	0:erd		IMM												
	AND.L ERs,ERd	L	0	1	F	0	6	6	0:ers	0:erd										
	ANDC #xx:8,CCR	B	0	6	IMM															
	ANDC #xx:8,EXR	B	0	1	4	1	0	6	IMM											
	BAND	BAND #xx:3,Rd	B	7	6	0:IMM	rd													
Bcc	BAND #xx:3,@ERd	B	7	C	0	erd	0	7	6	0:IMM	0									
	BAND #xx:3,@aa:8	B	7	E	abs			7	6	0:IMM	0									
	BAND #xx:3,@aa:16	B	6	A	1	0	abs	7	6	0:IMM	0									
	BAND #xx:3,@aa:32	B	6	A	3	0	abs	7	6	0:IMM	0									
	BRA d:8 (BT d:8)	—	4	0	disp															
BRN	BRA d:16 (BT d:16)	—	5	8	0	0	disp													
	BRN d:8 (BF d:8)	—	4	1	disp															
	BRN d:16 (BF d:16)	—	5	8	1	0	disp													

Instruction	Mnemonic	Size	Instruction Format																						
			1st byte	2nd byte	3rd byte	4th byte	5th byte	6th byte	7th byte	8th byte	9th byte	10th byte													
Bcc	BHI d:8	—	4	2	disp																				
	BHI d:16	—	5	8	2	0	disp																		
	BLS d:8	—	4	3	disp																				
	BLS d:16	—	5	8	3	0	disp																		
	BCC d:8 (BHS d:8)	—	4	4	disp																				
	BCC d:16 (BHS d:16)	—	5	8	4	0	disp																		
	BCS d:8 (BLO d:8)	—	4	5	disp																				
	BCS d:16 (BLO d:16)	—	5	8	5	0	disp																		
	BNE d:8	—	4	6	disp																				
	BNE d:16	—	5	8	6	0	disp																		
	BEQ d:8	—	4	7	disp																				
	BEQ d:16	—	5	8	7	0	disp																		
	BVC d:8	—	4	8	disp																				
	BVC d:16	—	5	8	8	0	disp																		
	BVS d:8	—	4	9	disp																				
	BVS d:16	—	5	8	9	0	disp																		
BPL d:8	—	4	A	disp																					
BPL d:16	—	5	8	A	0	disp																			
BMI d:8	—	4	B	disp																					
BMI d:16	—	5	8	B	0	disp																			
BGE d:8	—	4	C	disp																					
BGE d:16	—	5	8	C	0	disp																			
BLT d:8	—	4	D	disp																					
BLT d:16	—	5	8	D	0	disp																			
BGT d:8	—	4	E	disp																					
BGT d:16	—	5	8	E	0	disp																			
BLE d:8	—	4	F	disp																					
BLE d:16	—	5	8	F	0	disp																			

Instruction	Mnemonic	Size	Instruction Format																	
			1st byte	2nd byte	3rd byte	4th byte	5th byte	6th byte	7th byte	8th byte	9th byte	10th byte								
BIST	BIST #xx:3,Rd	B	6	7	1:IMM	rd														
	BIST #xx:3,@ERd	B	7	D	0:erd	0	6	7	1:IMM	0										
	BIST #xx:3,@aa:8	B	7	F	abs		6	7	1:IMM	0										
	BIST #xx:3,@aa:16	B	6	A	1	8			abs											
	BIST #xx:3,@aa:32	B	6	A	3	8			abs				6	7	1:IMM	0				
BIXOR	BIXOR #xx:3,Rd	B	7	5	1:IMM	rd														
	BIXOR #xx:3,@ERd	B	7	C	0:erd	0	7	5	1:IMM	0										
	BIXOR #xx:3,@aa:8	B	7	E	abs		7	5	1:IMM	0										
	BIXOR #xx:3,@aa:16	B	6	A	1	0			abs				7	5	1:IMM	0				
	BIXOR #xx:3,@aa:32	B	6	A	3	0			abs				7	5	1:IMM	0				
BLD	BLD #xx:3,Rd	B	7	7	0:IMM	rd														
	BLD #xx:3,@ERd	B	7	C	0:erd	0	7	7	0:IMM	0										
	BLD #xx:3,@aa:8	B	7	E	abs		7	7	0:IMM	0										
	BLD #xx:3,@aa:16	B	6	A	1	0			abs				7	7	0:IMM	0				
	BLD #xx:3,@aa:32	B	6	A	3	0			abs				7	7	0:IMM	0				
BNOT	BNOT #xx:3,Rd	B	7	1	0:IMM	rd														
	BNOT #xx:3,@ERd	B	7	D	0:erd	0	7	1	0:IMM	0										
	BNOT #xx:3,@aa:8	B	7	F	abs		7	1	0:IMM	0										
	BNOT #xx:3,@aa:16	B	6	A	1	8			abs				7	1	0:IMM	0				
	BNOT #xx:3,@aa:32	B	6	A	3	8			abs				7	1	0:IMM	0				
	BNOT Rn,Rd	B	6	1	rn	rd														
	BNOT Rn,@ERd	B	7	D	0:erd	0	6	1	rn	0										
	BNOT Rn,@aa:8	B	7	F	abs		6	1	rn	0										
BNOT Rn,@aa:16	B	6	A	1	8			abs				6	1	rn	0					
BNOT Rn,@aa:32	B	6	A	3	8			abs				6	1	rn	0					

Instruction	Mnemonic	Size	Instruction Format																	
			1st byte	2nd byte	3rd byte	4th byte	5th byte	6th byte	7th byte	8th byte	9th byte	10th byte								
BTST	BTST Rn,@aa:8	B	7	E	6	3	rn	0												
	BTST Rn,@aa:16	B	6	A	1	0	abs	6	3	rn	0									
	BTST Rn,@aa:32	B	6	A	3	0	abs	abs												
BXOR	BXOR #xx:3,Rd	B	7	5	0:IMM	rd														
	BXOR #xx:3,@ERd	B	7	C	0:erd	0	7	5	0:IMM	0										
	BXOR #xx:3,@aa:8	B	7	E	abs	7	5	0:IMM	0											
	BXOR #xx:3,@aa:16	B	6	A	1	0	abs	7	5	0:IMM	0									
	BXOR #xx:3,@aa:32	B	6	A	3	0	abs	abs												
	CLRMAC	CLRMAC	—	Cannot be used in the H8S/2355 Series																
CMP	CMP.B #xx:8,Rd	B	A	rd	IMM															
	CMP.B Rs,Rd	B	1	C	rs	rd														
	CMP.W #xx:16,Rd	W	7	9	2	rd	IMM													
	CMP.W Rs,Rd	W	1	D	rs	rd														
	CMP.L #xx:32,ERd	L	7	A	2	0:erd														
	CMP.L ERs,ERd	L	1	F	1:ers	0:erd														
DAA	DAA Rd	B	0	F	0	rd														
DAS	DAS Rd	B	1	F	0	rd														
DEC	DEC.B Rd	B	1	A	0	rd														
	DEC.W #1,Rd	W	1	B	5	rd														
	DEC.W #2,Rd	W	1	B	D	rd														
	DEC.L #1,ERd	L	1	B	7	0:erd														
	DEC.L #2,ERd	L	1	B	F	0:erd														
DIVXS	DIVXS.B Rs,Rd	B	0	1	D	0	5	1	rs	rd										
	DIVXS.W Rs,ERd	W	0	1	D	0	5	3	rs	0:erd										
DIVXU	DIVXU.B Rs,Rd	B	5	1	rs	rd														
	DIVXU.W Rs,ERd	W	5	3	rs	0:erd														
EEPMOV	EEPMOV.B	—	7	B	5	C	5	9	8	F										
	EEPMOV.W	—	7	B	D	4	5	9	8	F										

Instruction	Mnemonic	Size	Instruction Format													
			1st byte	2nd byte	3rd byte	4th byte	5th byte	6th byte	7th byte	8th byte	9th byte	10th byte				
LDC	LDC @aa:32,CCR	W	0	1	4	0	6	B	2	0	abs					
	LDC @aa:32,EXR	W	0	1	4	1	6	B	2	0	abs					
LDM	LDM.L @SP+, (ERn-ERn+1)	L	0	1	1	0	6	D	7	0,erh+1						
	LDM.L @SP+, (ERn-ERn+2)	L	0	1	2	0	6	D	7	0,erh+2						
	LDM.L @SP+, (ERn-ERn+3)	L	0	1	3	0	6	D	7	0,erh+3						
LDMAC	LDMAC ERs,MACH	L	Cannot be used in the H8S/2355 Series													
MAC	LDMAC ERs,MACL	L														
	MAC @ERn+,@ERm+	—														
MOV	MOV.B #xx:8,Rd	B	F	rd	IMM											
	MOV.B Rs,Rd	B	0	C	rs	rd										
	MOV.B @ERs,Rd	B	6	8	0:ers	rd										
	MOV.B @(d:16,ERs),Rd	B	6	E	0:ers	rd	disp									
	MOV.B @(d:32,ERs),Rd	B	7	8	0:ers	0	6	A	2	rd	disp					
	MOV.B @ERs+,Rd	B	6	C	0:ers	rd										
	MOV.B @aa:8,Rd	B	2	rd	abs											
	MOV.B @aa:16,Rd	B	6	A	0	rd	abs									
	MOV.B @aa:32,Rd	B	6	A	2	rd	abs									
	MOV.B Rs,@ERd	B	6	8	1:erd	rs										
	MOV.B Rs,@(d:16,ERd)	B	6	E	1:erd	rs	disp									
	MOV.B Rs,@(d:32,ERd)	B	7	8	0:erd	0	6	A	A	rs	disp					
	MOV.B Rs,@-ERd	B	6	C	1:erd	rs										
	MOV.B Rs,@aa:8	B	3	rs	abs											
	MOV.B Rs,@aa:16	B	6	A	8	rs	abs									
MOV.B Rs,@aa:32	B	6	A	A	rs	abs										
MOV.W #xx:16,Rd	W	7	9	0	rd	IMM										
MOV.W Rs,Rd	W	0	D	rs	rd											
MOV.W @ERs,Rd	W	6	9	0:ers	rd											
MOV.W @(d:16,ERs),Rd	W	6	F	0:ers	rd	disp										
MOV.W @(d:32,ERs),Rd	W	7	8	0:ers	0	6	B	2	rd	disp						

Instruction	Mnemonic	Size	Instruction Format																		
			1st byte	2nd byte	3rd byte	4th byte	5th byte	6th byte	7th byte	8th byte	9th byte	10th byte									
MOV	MOV.W @ERS+,Rd	W	6	D	0:ers	rd															
	MOV.W @aa:16,Rd	W	6	B	0	rd	abs														
	MOV.W @aa:32,Rd	W	6	B	2	rd	abs														
	MOV.W Rs,@ERd	W	6	9	1:erd	rs															
	MOV.W Rs,@(d:16,ERd)	W	6	F	1:erd	rs	disp														
	MOV.W Rs,@(d:32,ERd)	W	7	8	0:erd	0	6	B	A	rs		disp									
	MOV.W Rs,@-ERd	W	6	D	1:erd	rs															
	MOV.W Rs,@aa:16	W	6	B	8	rs	abs														
	MOV.W Rs,@aa:32	W	6	B	A	rs	abs														
	MOV.L #xx:32,Rd	L	7	A	0	0:erd															
	MOV.L ERs,ERd	L	0	F	1:ers	0:erd															
	MOV.L @ERS,ERd	L	0	1	0	0	6	9	0:ers	0:erd											
	MOV.L @(d:16,ERs),ERd	L	0	1	0	0	6	F	0:ers	0:erd	disp										
	MOV.L @(d:32,ERs),ERd	L	0	1	0	0	7	8	0:ers	0	6	B	2	0:erd							disp
	MOV.L @ERS+,ERd	L	0	1	0	0	6	D	0:ers	0:erd											
	MOV.L @aa:16,ERd	L	0	1	0	0	6	B	0	0:erd	abs										
	MOV.L @aa:32,ERd	L	0	1	0	0	6	B	2	0:erd	abs										
	MOV.L ERs,@ERd	L	0	1	0	0	6	9	1:erd	0:ers											
	MOV.L ERs,@(d:16,ERd)	L	0	1	0	0	6	F	1:erd	0:ers	disp										
MOV.L ERs,@(d:32,ERd)*	L	0	1	0	0	7	8	0:erd	0	6	B	A	0:ers							disp	
MOV.L ERs,@-ERd	L	0	1	0	0	6	D	1:erd	0:ers												
MOV.L ERs,@aa:16	L	0	1	0	0	6	B	8	0:ers	abs											
MOV.L ERs,@aa:32	L	0	1	0	0	6	B	A	0:ers	abs											
MOVFPPE @aa:16,Rd	B	Cannot be used in the H8S/Z355 Series																			
MOVTPPE	MOVTPPE Rs,@aa:16	B																			
MULXS	MULXS.B Rs,Rd	B	0	1	C	0	5	0	rs	rd											
	MULXS.W Rs,ERd	W	0	1	C	0	5	2	rs	0:erd											
MULXU	MULXU.B Rs,Rd	B	5	0	rs	rd															
	MULXU.W Rs,ERd	W	5	2	rs	0:erd															

Instruction	Mnemonic	Size	Instruction Format																	
			1st byte	2nd byte	3rd byte	4th byte	5th byte	6th byte	7th byte	8th byte	9th byte	10th byte								
NEG	NEG.B Rd	B	1	7	8	rd														
	NEG.W Rd	W	1	7	9	rd														
	NEG.L ERd	L	1	7	B	0:erd														
NOP	NOP	—	0	0	0	0														
NOT	NOT.B Rd	B	1	7	0	rd														
	NOT.W Rd	W	1	7	1	rd														
	NOT.L ERd	L	1	7	3	0:erd														
OR	OR.B #xx:8,Rd	B	C	rd	IMM															
	OR.B Rs,Rd	B	1	4	rs	rd														
	OR.W #xx:16,Rd	W	7	9	4	rd	IMM													
	OR.W Rs,Rd	W	6	4	rs	rd														
	OR.L #xx:32,ERd	L	7	A	4	0:erd														
	OR.L ERs,ERd	L	0	1	F	0	6	4	0:ers	0:erd										
ORC	ORC #xx:8,CCR	B	0	4	IMM															
	ORC #xx:8,EXR	B	0	1	4	1	0	4	IMM											
POP	POP.W Rn	W	6	D	7	rn														
	POP.L ERn	L	0	1	0	0	6	D	7	0:ern										
PUSH	PUSH.W Rn	W	6	D	F	rn														
	PUSH.L ERn	L	0	1	0	0	6	D	F	0:ern										
ROTL	ROTL.B Rd	B	1	2	8	rd														
	ROTL.B #2, Rd	B	1	2	C	rd														
	ROTL.W Rd	W	1	2	9	rd														
	ROTL.W #2, Rd	W	1	2	D	rd														
	ROTL.L ERd	L	1	2	B	0:erd														
ROTL.L #2, ERd	L	1	2	F	0:erd															

Instruction	Mnemonic	Size	Instruction Format																	
			1st byte	2nd byte	3rd byte	4th byte	5th byte	6th byte	7th byte	8th byte	9th byte	10th byte								
SHAR	SHAR.B Rd	B	1	1	8	rd														
	SHAR.B #2, Rd	B	1	1	C	rd														
	SHAR.W Rd	W	1	1	9	rd														
	SHAR.W #2, Rd	W	1	1	D	rd														
	SHAR.L ERd	L	1	1	B	0:erd														
	SHAR.L #2, ERd	L	1	1	F	0:erd														
SHLL	SHLL.B Rd	B	1	0	0	rd														
	SHLL.B #2, Rd	B	1	0	4	rd														
	SHLL.W Rd	W	1	0	1	rd														
	SHLL.W #2, Rd	W	1	0	5	rd														
	SHLL.L ERd	L	1	0	3	0:erd														
	SHLL.L #2, ERd	L	1	0	7	0:erd														
SHLR	SHLR.B Rd	B	1	1	0	rd														
	SHLR.B #2, Rd	B	1	1	4	rd														
	SHLR.W Rd	W	1	1	1	rd														
	SHLR.W #2, Rd	W	1	1	5	rd														
	SHLR.L ERd	L	1	1	3	0:erd														
	SHLR.L #2, ERd	L	1	1	7	0:erd														
SLEEP	SLEEP	—	0	1	8	0														
STC	STC.B CCR,Rd	B	0	2	0	rd														
	STC.B EXR,Rd	B	0	2	1	rd														
	STC.W CCR,@ERd	W	0	1	4	0	6	9	1:erd	0										
	STC.W EXR,@ERd	W	0	1	4	1	6	9	1:erd	0										
	STC.W CCR,@(d:16,ERd)	W	0	1	4	0	6	F	1:erd	0										
	STC.W EXR,@(d:16,ERd)	W	0	1	4	1	6	F	1:erd	0										
	STC.W CCR,@(d:32,ERd)	W	0	1	4	0	7	8	0:erd	0	6	B	A	0						
	STC.W EXR,@(d:32,ERd)	W	0	1	4	1	7	8	0:erd	0	6	B	A	0						
STC.W CCR,@-ERd	W	0	1	4	0	6	D	1:erd	0											
STC.W EXR,@-ERd	W	0	1	4	1	6	D	1:erd	0											

Instruction	Mnemonic	Size	Instruction Format													
			1st byte	2nd byte	3rd byte	4th byte	5th byte	6th byte	7th byte	8th byte	9th byte	10th byte				
XORC	XORC #xx:8.CCR	B	0	5	IMM											
	XORC #xx:8.EXR	B	0	1	4	1	0	5	IMM							

Note: * Bit 7 of the 4th byte of the MOV.L ERs, @(d):32,ERd) instruction can be either 1 or 0.

Legend

IMM: Immediate data (2, 3, 8, 16, or 32 bits)

abs: Absolute address (8, 16, 24, or 32 bits)

disp: Displacement (8, 16, or 32 bits)

rs, rd, rn: Register field (4 bits specifying an 8-bit or 16-bit register. The symbols rs, rd, and rn correspond to operand symbols Rs, Rd, and Rn.)

ers, erd, ern, erm: Register field (3 bits specifying an address register or 32-bit register. The symbols ers, erd, ern, and erm correspond to operand symbols ERs, ERd, ERn, and ERm.)

The register fields specify general registers as follows.

Address Register		16-Bit Register		8-Bit Register	
Register Field	General Register	Register Field	General Register	Register Field	General Register
000	ER0	0000	R0	0000	R0H
001	ER1	0001	R1	0001	R1H
•	•	•	•	•	•
•	•	•	•	•	•
111	ER7	0111	R7	0111	R7H
		1000	E0	1000	R0L
		1001	E1	1001	R1L
		•	•	•	•
		•	•	•	•
		1111	E7	1111	R7L

A.3 Operation Code Map

Table A-3 shows the operation code map.

Table A-3 Operation Code Map (1)

Instruction code		1st byte		2nd byte																	
		AH	AL	BH	BL	0	1	2	3	4	5	6	7	8	9	A	B	C	D	E	F
0	NOP Table A.3(2)	Table A.3(2)	STC Table A.3(2)	STMAC Table A.3(2)	LDC Table A.3(2)	ORC	XORC	ANDC	LDC	ADD	Table A.3(2)	Table A.3(2)	Table A.3(2)	Table A.3(2)	Table A.3(2)	Table A.3(2)	Table A.3(2)	Table A.3(2)	Table A.3(2)	Table A.3(2)	Table A.3(2)
1	Table A.3(2)	Table A.3(2)	Table A.3(2)	Table A.3(2)	OR	XOR	AND	AND	Table A.3(2)	SUB	Table A.3(2)	Table A.3(2)	Table A.3(2)	Table A.3(2)	Table A.3(2)	Table A.3(2)	Table A.3(2)	Table A.3(2)	Table A.3(2)	Table A.3(2)	Table A.3(2)
2	MOV.B																				
3	MOV.B																				
4	BRA	BRN	BHI	BLS	BCC	BCS	BNE	BEQ	BVC	BVS	BPL	BMI	BGE	BLT	BGT	BLE					
5	MULXU	DIVXU	MULXU	DIVXU	RTS	BSR	RTE	TRAPA	Table A.3(2)		JMP				JSR						
6	BSET	BNOT	BCLR	BTST	OR	XOR	AND	BST	MOV	MOV	Table A.3(2)				MOV						
7					BOR BIOR	BXOR BIXOR	BAND BIAND	BLD BILD	MOV	MOV	Table A.3(2)	EEP	MOV	Table A.3(3)							
8	ADD																				
9	ADDX																				
A	CMP																				
B	SUBX																				
C	OR																				
D	XOR																				
E	AND																				
F	MOV																				

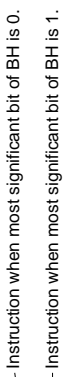

Note: * Cannot be used in the H8S/2355 Series.

Table A-3 Operation Code Map (2)

Instruction code		1st byte		2nd byte	
		AH	AL	BH	BL

BH AH AL	0	1	2	3	4	5	6	7	8	9	A	B	C	D	E	F
01	MOV	LDM	STM	LDC STC	MAC*			SLEEP			CLRMAC*		Table A.3(3)	Table A.3(3)	TAS	Table A.3(3)
0A	INC												ADD			
0B	ADDS					INC		INC	ADDS					INC		INC
0F	DAA												MOV			
10	SHLL				SHLL			SHLL	SHAL				SHAL			SHAL
11	SHLR				SHLR			SHLR	SHAR				SHAR			SHAR
12	ROTXL				ROTXL			ROTXL	ROTL				ROTL			ROTL
13	ROTXR				ROTXR			ROTXR	ROTR				ROTR			ROTR
17	NOT					EXTU		EXTU	NEG			NEG		EXTS		EXTS
1A	DEC												SUB			
1B	SUBS					DEC		DEC	SUBS					DEC		DEC
1F	DAS												CMP			
58	BRA	BRN	BHI	BLS	BCC	BCS	BNE	BEQ	BVC	BVS	BPL	BMI	BGE	BLT	BGT	BLE
6A	MOV	Table A.3(4)	MOV	Table A.3(4)	MOVFP*				MOV		MOV		MOV			MOV
79	MOV	ADD	CMP	SUB	OR	XOR	AND									
7A	MOV	ADD	CMP	SUB	OR	XOR	AND									

Note: * Cannot be used in the H8S/2355 Series.

Table A-3 Operation Code Map (3)

Instruction code		1st byte		2nd byte		3rd byte		4th byte	
		AH	AL	BH	BL	CH	CL	DH	DL



	0	1	2	3	4	5	6	7	8	9	A	B	C	D	E	F
CL																
AH AL BH CH																
01C05	MULXS		MULXS													
01D05		DIVXS		DIVXS												
01F06					OR	XOR	AND									
7Cr06 *1				BTST												
7Cr07 *1				BTST	BOR	BXOR	BAND	BLD								
7Dr06 *1	BSET	BNOT	BCLR		BIOR	BIXOR	BIAND	BILD								
7Dr07 *1	BSET	BNOT	BCLR					BST								
7Ea6 *2				BTST												
7Ea7 *2				BTST	BOR	BXOR	BAND	BLD								
7Fa6 *2	BSET	BNOT	BCLR		BIOR	BIXOR	BIAND	BILD								
7Fa7 *2	BSET	BNOT	BCLR					BST								

Notes: 1. r is the register specification field.

2. aa is the absolute address specification.

Table A-3 Operation Code Map (4)

Instruction code		1st byte		2nd byte		3rd byte		4th byte		5th byte		6th byte					
AH	AL	BH	BL	CH	CL	DH	DL	EH	EL	FH	FL						
EL AHLBHLCHCLDHLFLH		0	1	2	3	4	5	6	7	8	9	A	B	C	D	E	F
6A10aaaa6*					BTST												
6A10aaaa7*						BOR BIOR	BXOR BIXOR	BAND BIAND	BLD BILD BST BIST								
6A18aaaa6*																	
6A18aaaa7*																	

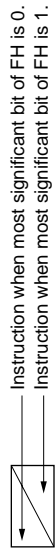

Instruction code		1st byte		2nd byte		3rd byte		4th byte		5th byte		6th byte		7th byte		8th byte	
AH	AL	BH	BL	CH	CL	DH	DL	EH	EL	FH	FL	GH	GL	HH	HL		
GL AHLBHL... FHLGH		0	1	2	3	4	5	6	7	8	9	A	B	C	D	E	F
6A30aaaaaaa6*					BTST												
6A30aaaaaaa7*						BOR BIOR	BXOR BIXOR	BAND BIAND	BLD BILD BST BIST								
6A38aaaaaaa6*																	
6A38aaaaaaa7*																	

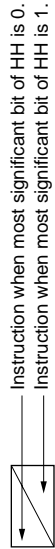

Note: * aa is the absolute address specification.

A.4 Number of States Required for Instruction Execution

The tables in this section can be used to calculate the number of states required for instruction execution by the CPU. Table A-5 indicates the number of instruction fetch, data read/write, and other cycles occurring in each instruction. Table A-4 indicates the number of states required for each cycle. The number of states required for execution of an instruction can be calculated from these two tables as follows:

$$\text{Execution states} = I \times S_I + J \times S_J + K \times S_K + L \times S_L + M \times S_M + N \times S_N$$

Examples: Advanced mode, program code and stack located in external memory, on-chip supporting modules accessed in two states with 8-bit bus width, external devices accessed in three states with one wait state and 16-bit bus width.

1. BSET #0, @FFFC7:8

From table A-5:

$$I = L = 2, \quad J = K = M = N = 0$$

From table A-4:

$$S_I = 4, \quad S_L = 2$$

$$\text{Number of states required for execution} = 2 \times 4 + 2 \times 2 = 12$$

2. JSR @@30

From table A-5:

$$I = J = K = 2, \quad L = M = N = 0$$

From table A-4:

$$S_I = S_J = S_K = 4$$

$$\text{Number of states required for execution} = 2 \times 4 + 2 \times 4 + 2 \times 4 = 24$$

Table A-4 Number of States per Cycle

		Access Conditions						
		On-Chip Memory	On-Chip Supporting Module		External Device			
			8-Bit Bus	16-Bit Bus	8-Bit Bus		16-Bit Bus	
Cycle				2-State Access	3-State Access	2-State Access	3-State Access	
Instruction fetch	S_I	1	4	2	4	6 + 2m	2	3 + m
Branch address read	S_J							
Stack operation	S_K							
Byte data access	S_L		2		2	3 + m		
Word data access	S_M		4		4	6 + 2m		
Internal operation	S_N	1	1	1	1	1	1	1

Legend

m: Number of wait states inserted into external device access

Table A-5 Number of Cycles in Instruction Execution

Instruction	Mnemonic	Instruction	Branch	Stack	Byte Data	Word Data	Internal
		Fetch	Address	Operation	Access	Access	Operation
		I	J	K	L	M	N
ADD	ADD.B #xx:8,Rd	1					
	ADD.B Rs,Rd	1					
	ADD.W #xx:16,Rd	2					
	ADD.W Rs,Rd	1					
	ADD.L #xx:32,ERd	3					
	ADD.L ERs,ERd	1					
ADDS	ADDS #1/2/4,ERd	1					
ADDX	ADDX #xx:8,Rd	1					
	ADDX Rs,Rd	1					
AND	AND.B #xx:8,Rd	1					
	AND.B Rs,Rd	1					
	AND.W #xx:16,Rd	2					
	AND.W Rs,Rd	1					
	AND.L #xx:32,ERd	3					
	AND.L ERs,ERd	2					
ANDC	ANDC #xx:8,CCR	1					
	ANDC #xx:8,EXR	2					
BAND	BAND #xx:3,Rd	1					
	BAND #xx:3,@ERd	2			1		
	BAND #xx:3,@aa:8	2			1		
	BAND #xx:3,@aa:16	3			1		
	BAND #xx:3,@aa:32	4			1		
Bcc	BRA d:8 (BT d:8)	2					
	BRN d:8 (BF d:8)	2					
	BHI d:8	2					
	BLS d:8	2					
	BCC d:8 (BHS d:8)	2					
	BCS d:8 (BLO d:8)	2					
	BNE d:8	2					
	BEQ d:8	2					
	BVC d:8	2					
	BVS d:8	2					
	BPL d:8	2					
	BMI d:8	2					
	BGE d:8	2					
	BLT d:8	2					
	BGT d:8	2					
	BLE d:8	2					
	BRA d:16 (BT d:16)	2					1
	BRN d:16 (BF d:16)	2					1

Instruction	Mnemonic	Instruction	Branch	Stack	Byte Data	Word Data	Internal
		Fetch	Address	Operation	Access	Access	Operation
		I	J	K	L	M	N
Bcc	BHI d:16	2					1
	BLS d:16	2					1
	BCC d:16 (BHS d:16)	2					1
	BCS d:16 (BLO d:16)	2					1
	BNE d:16	2					1
	BEQ d:16	2					1
	BVC d:16	2					1
	BVS d:16	2					1
	BPL d:16	2					1
	BMI d:16	2					1
	BGE d:16	2					1
	BLT d:16	2					1
	BGT d:16	2					1
	BLE d:16	2					1
BCLR	BCLR #xx:3,Rd	1					
	BCLR #xx:3,@ERd	2			2		
	BCLR #xx:3,@aa:8	2			2		
	BCLR #xx:3,@aa:16	3			2		
	BCLR #xx:3,@aa:32	4			2		
	BCLR Rn,Rd	1					
	BCLR Rn,@ERd	2			2		
	BCLR Rn,@aa:8	2			2		
	BCLR Rn,@aa:16	3			2		
BCLR Rn,@aa:32	4			2			
BIAND	BIAND #xx:3,Rd	1					
	BIAND #xx:3,@ERd	2			1		
	BIAND #xx:3,@aa:8	2			1		
	BIAND #xx:3,@aa:16	3			1		
	BIAND #xx:3,@aa:32	4			1		
BILD	BILD #xx:3,Rd	1					
	BILD #xx:3,@ERd	2			1		
	BILD #xx:3,@aa:8	2			1		
	BILD #xx:3,@aa:16	3			1		
	BILD #xx:3,@aa:32	4			1		
BIOR	BIOR #xx:8,Rd	1					
	BIOR #xx:8,@ERd	2			1		
	BIOR #xx:8,@aa:8	2			1		
	BIOR #xx:8,@aa:16	3			1		
	BIOR #xx:8,@aa:32	4			1		

Instruction	Mnemonic	Instruction	Branch	Stack	Byte Data	Word Data	Internal
		Fetch	Address	Operation	Access	Access	Operation
		I	J	K	L	M	N
BIST	BIST #xx:3,Rd	1					
	BIST #xx:3,@ERd	2			2		
	BIST #xx:3,@aa:8	2			2		
	BIST #xx:3,@aa:16	3			2		
	BIST #xx:3,@aa:32	4			2		
BIXOR	BIXOR #xx:3,Rd	1					
	BIXOR #xx:3,@ERd	2			1		
	BIXOR #xx:3,@aa:8	2			1		
	BIXOR #xx:3,@aa:16	3			1		
	BIXOR #xx:3,@aa:32	4			1		
BLD	BLD #xx:3,Rd	1					
	BLD #xx:3,@ERd	2			1		
	BLD #xx:3,@aa:8	2			1		
	BLD #xx:3,@aa:16	3			1		
	BLD #xx:3,@aa:32	4			1		
BNOT	BNOT #xx:3,Rd	1					
	BNOT #xx:3,@ERd	2			2		
	BNOT #xx:3,@aa:8	2			2		
	BNOT #xx:3,@aa:16	3			2		
	BNOT #xx:3,@aa:32	4			2		
	BNOT Rn,Rd	1					
	BNOT Rn,@ERd	2			2		
	BNOT Rn,@aa:8	2			2		
	BNOT Rn,@aa:16	3			2		
BNOT Rn,@aa:32	4			2			
BOR	BOR #xx:3,Rd	1					
	BOR #xx:3,@ERd	2			1		
	BOR #xx:3,@aa:8	2			1		
	BOR #xx:3,@aa:16	3			1		
	BOR #xx:3,@aa:32	4			1		
BSET	BSET #xx:3,Rd	1					
	BSET #xx:3,@ERd	2			2		
	BSET #xx:3,@aa:8	2			2		
	BSET #xx:3,@aa:16	3			2		
	BSET #xx:3,@aa:32	4			2		
	BSET Rn,Rd	1					
	BSET Rn,@ERd	2			2		
	BSET Rn,@aa:8	2			2		
	BSET Rn,@aa:16	3			2		
BSET Rn,@aa:32	4			2			

Instruction	Mnemonic		Instruction	Branch	Stack	Byte Data	Word Data	Internal
			Fetch	Address	Operation	Access	Access	Operation
			I	J	K	L	M	N
BSR	BSR d:8	Normal	2		1			
		Advanced	2		2			
	BSR d:16	Normal	2		1			1
		Advanced	2		2			1
BST	BST #xx:3,Rd		1					
	BST #xx:3,@ERd		2			2		
	BST #xx:3,@aa:8		2			2		
	BST #xx:3,@aa:16		3			2		
	BST #xx:3,@aa:32		4			2		
BTST	BTST #xx:3,Rd		1					
	BTST #xx:3,@ERd		2			1		
	BTST #xx:3,@aa:8		2			1		
	BTST #xx:3,@aa:16		3			1		
	BTST #xx:3,@aa:32		4			1		
	BTST Rn,Rd		1					
	BTST Rn,@ERd		2			1		
	BTST Rn,@aa:8		2			1		
	BTST Rn,@aa:16		3			1		
BTST Rn,@aa:32		4			1			
BXOR	BXOR #xx:3,Rd		1					
	BXOR #xx:3,@ERd		2			1		
	BXOR #xx:3,@aa:8		2			1		
	BXOR #xx:3,@aa:16		3			1		
	BXOR #xx:3,@aa:32		4			1		
CLRMAC	CLRMAC	Cannot be used in the H8S/2355 Series						
CMP	CMP.B #xx:8,Rd		1					
	CMP.B Rs,Rd		1					
	CMP.W #xx:16,Rd		2					
	CMP.W Rs,Rd		1					
	CMP.L #xx:32,ERd		3					
	CMP.L ERs,ERd		1					
DAA	DAA Rd		1					
DAS	DAS Rd		1					
DEC	DEC.B Rd		1					
	DEC.W #1/2,Rd		1					
	DEC.L #1/2,ERd		1					
DIVXS	DIVXS.B Rs,Rd		2					11
	DIVXS.W Rs,ERd		2					19
DIVXU	DIVXU.B Rs,Rd		1					11
	DIVXU.W Rs,ERd		1					19

Instruction	Mnemonic	Branch						
		Instruction Fetch	Address Read	Stack Operation	Byte Data Access	Word Data Access	Internal Operation	
		I	J	K	L	M	N	
EEPMOV	EEPMOV.B	2			2n+2 *2			
	EEPMOV.W	2			2n+2 *2			
EXTS	EXTS.W Rd	1						
	EXTS.L ERd	1						
EXTU	EXTU.W Rd	1						
	EXTU.L ERd	1						
INC	INC.B Rd	1						
	INC.W #1/2,Rd	1						
	INC.L #1/2,ERd	1						
JMP	JMP @ERn	2						
	JMP @aa:24	2					1	
	JMP @@aa:8	Normal	2	1				1
		Advanced	2	2				1
JSR	JSR @ERn	Normal	2		1			
		Advanced	2		2			
	JSR @aa:24	Normal	2		1			1
		Advanced	2		2			1
	JSR @@aa:8	Normal	2	1	1			
		Advanced	2	2	2			
LDC	LDC #xx:8,CCR	1						
	LDC #xx:8,EXR	2						
	LDC Rs,CCR	1						
	LDC Rs,EXR	1						
	LDC @ERs,CCR	2					1	
	LDC @ERs,EXR	2					1	
	LDC @(d:16,ERs),CCR	3					1	
	LDC @(d:16,ERs),EXR	3					1	
	LDC @(d:32,ERs),CCR	5					1	
	LDC @(d:32,ERs),EXR	5					1	
	LDC @ERs+,CCR	2					1	1
	LDC @ERs+,EXR	2					1	1
	LDC @aa:16,CCR	3					1	
	LDC @aa:16,EXR	3					1	
	LDC @aa:32,CCR	4					1	
	LDC @aa:32,EXR	4					1	
	LDM	LDM.L @SP+, (ERn-ERn+1)	2		4			1
LDM.L @SP+, (ERn-ERn+2)		2		6			1	
LDM.L @SP+, (ERn-ERn+3)		2		8			1	
LDMAC	LDMAC ERs,MACH	Cannot be used in the H8S/2355 Series						
	LDMAC ERs,MACL							

Instruction	Mnemonic	Instruction	Branch	Stack	Byte Data	Word Data	Internal	
		Fetch	Address	Operation	Access	Access	Operation	
		I	J	K	L	M	N	
MAC	MAC @ERn+,@ERm+	Cannot be used in the H8S/2355 Series						
MOV	MOV.B #xx:8,Rd	1						
	MOV.B Rs,Rd	1						
	MOV.B @ERs,Rd	1			1			
	MOV.B @(d:16,ERs),Rd	2			1			
	MOV.B @(d:32,ERs),Rd	4			1			
	MOV.B @ERs+,Rd	1			1		1	
	MOV.B @aa:8,Rd	1			1			
	MOV.B @aa:16,Rd	2			1			
	MOV.B @aa:32,Rd	3			1			
	MOV.B Rs,@ERd	1			1			
	MOV.B Rs,@(d:16,ERd)	2			1			
	MOV.B Rs,@(d:32,ERd)	4			1			
	MOV.B Rs,@-ERd	1			1		1	
	MOV.B Rs,@aa:8	1			1			
	MOV.B Rs,@aa:16	2			1			
	MOV.B Rs,@aa:32	3			1			
	MOV.W #xx:16,Rd	2						
	MOV.W Rs,Rd	1						
	MOV.W @ERs,Rd	1				1		
	MOV.W @(d:16,ERs),Rd	2				1		
	MOV.W @(d:32,ERs),Rd	4				1		
	MOV.W @ERs+,Rd	1				1	1	
	MOV.W @aa:16,Rd	2				1		
	MOV.W @aa:32,Rd	3				1		
	MOV.W Rs,@ERd	1				1		
	MOV.W Rs,@(d:16,ERd)	2				1		
	MOV.W Rs,@(d:32,ERd)	4				1		
	MOV.W Rs,@-ERd	1				1	1	
	MOV.W Rs,@aa:16	2				1		
	MOV.W Rs,@aa:32	3				1		
	MOV.L #xx:32,ERd	3						
	MOV.L ERs,ERd	1						
	MOV.L @ERs,ERd	2				2		
	MOV.L @(d:16,ERs),ERd	3				2		
	MOV.L @(d:32,ERs),ERd	5				2		
	MOV.L @ERs+,ERd	2				2	1	
	MOV.L @aa:16,ERd	3				2		
	MOV.L @aa:32,ERd	4				2		
	MOV.L ERs,@ERd	2				2		
	MOV.L ERs,@(d:16,ERd)	3				2		

Instruction	Mnemonic	Instruction	Branch	Stack	Byte Data	Word Data	Internal
		Fetch	Address	Operation	Access	Access	Operation
		I	J	K	L	M	N
MOV	MOV.L ERs, @(d:32,ERd)	5				2	
	MOV.L ERs, @-ERd	2				2	1
	MOV.L ERs, @aa:16	3				2	
	MOV.L ERs, @aa:32	4				2	
MOVFPPE	MOVFPPE @:aa:16,Rd	Can not be used in the H8S/2355 Series					
MOVTPE	MOVTPE Rs, @:aa:16						
MULXS	MULXS.B Rs,Rd	2					11
	MULXS.W Rs,ERd	2					19
MULXU	MULXU.B Rs,Rd	1					11
	MULXU.W Rs,ERd	1					19
NEG	NEG.B Rd	1					
	NEG.W Rd	1					
	NEG.L ERd	1					
NOP	NOP	1					
NOT	NOT.B Rd	1					
	NOT.W Rd	1					
	NOT.L ERd	1					
OR	OR.B #xx:8,Rd	1					
	OR.B Rs,Rd	1					
	OR.W #xx:16,Rd	2					
	OR.W Rs,Rd	1					
	OR.L #xx:32,ERd	3					
	OR.L ERs,ERd	2					
ORC	ORC #xx:8,CCR	1					
	ORC #xx:8,EXR	2					
POP	POP.W Rn	1				1	1
	POP.L ERn	2				2	1
PUSH	PUSH.W Rn	1				1	1
	PUSH.L ERn	2				2	1
ROTL	ROTL.B Rd	1					
	ROTL.B #2,Rd	1					
	ROTL.W Rd	1					
	ROTL.W #2,Rd	1					
	ROTL.L ERd	1					
	ROTL.L #2,ERd	1					
ROTR	ROTR.B Rd	1					
	ROTR.B #2,Rd	1					
	ROTR.W Rd	1					
	ROTR.W #2,Rd	1					
	ROTR.L ERd	1					
	ROTR.L #2,ERd	1					

Instruction	Mnemonic		Instruction	Branch	Stack	Byte Data	Word Data	Internal
			Fetch	Address	Operation	Access	Access	Operation
			I	J	K	L	M	N
ROTXL	ROTXL.B Rd		1					
	ROTXL.B #2,Rd		1					
	ROTXL.W Rd		1					
	ROTXL.W #2,Rd		1					
	ROTXL.L ERd		1					
	ROTXL.L #2,ERd		1					
ROTXR	ROTXR.B Rd		1					
	ROTXR.B #2,Rd		1					
	ROTXR.W Rd		1					
	ROTXR.W #2,Rd		1					
	ROTXR.L ERd		1					
	ROTXR.L #2,ERd		1					
RTE	RTE		2		2 / 3 *1			1
RTS	RTS	Normal	2		1			1
		Advanced	2		2			1
SHAL	SHAL.B Rd		1					
	SHAL.B #2,Rd		1					
	SHAL.W Rd		1					
	SHAL.W #2,Rd		1					
	SHAL.L ERd		1					
	SHAL.L #2,ERd		1					
SHAR	SHAR.B Rd		1					
	SHAR.B #2,Rd		1					
	SHAR.W Rd		1					
	SHAR.W #2,Rd		1					
	SHAR.L ERd		1					
	SHAR.L #2,ERd		1					
SHLL	SHLL.B Rd		1					
	SHLL.B #2,Rd		1					
	SHLL.W Rd		1					
	SHLL.W #2,Rd		1					
	SHLL.L ERd		1					
	SHLL.L #2,ERd		1					
SHLR	SHLR.B Rd		1					
	SHLR.B #2,Rd		1					
	SHLR.W Rd		1					
	SHLR.W #2,Rd		1					
	SHLR.L ERd		1					
	SHLR.L #2,ERd		1					
SLEEP	SLEEP		1					1

Instruction	Mnemonic	Branch					
		Instruction Fetch	Address Read	Stack Operation	Byte Data Access	Word Data Access	Internal Operation
		I	J	K	L	M	N
STC	STC.B CCR,Rd	1					
	STC.B EXR,Rd	1					
	STC.W CCR,@ERd	2				1	
	STC.W EXR,@ERd	2				1	
	STC.W CCR,@(d:16,ERd)	3				1	
	STC.W EXR,@(d:16,ERd)	3				1	
	STC.W CCR,@(d:32,ERd)	5				1	
	STC.W EXR,@(d:32,ERd)	5				1	
	STC.W CCR,@-ERd	2				1	1
	STC.W EXR,@-ERd	2				1	1
	STC.W CCR,@aa:16	3				1	
	STC.W EXR,@aa:16	3				1	
	STC.W CCR,@aa:32	4				1	
STC.W EXR,@aa:32	4				1		
STM	STM.L (ERn-ERn+1),@-SP	2		4			1
	STM.L (ERn-ERn+2),@-SP	2		6			1
	STM.L (ERn-ERn+3),@-SP	2		8			1
STMAC	STMAC MACH,ERd	Cannot be used in the H8S/2355 Series					
	STMAC MACL,ERd						
SUB	SUB.B Rs,Rd	1					
	SUB.W #xx:16,Rd	2					
	SUB.W Rs,Rd	1					
	SUB.L #xx:32,ERd	3					
	SUB.L ERs,ERd	1					
SUBS	SUBS #1/2/4,ERd	1					
SUBX	SUBX #xx:8,Rd	1					
	SUBX Rs,Rd	1					
TAS	TAS @ERd	2			2		
TRAPA	TRAPA #x:2	Normal	2	1	2 / 3*1		2
		Advanced	2	2	2 / 3*1		2
XOR	XOR.B #xx:8,Rd	1					
	XOR.B Rs,Rd	1					
	XOR.W #xx:16,Rd	2					
	XOR.W Rs,Rd	1					
	XOR.L #xx:32,ERd	3					
	XOR.L ERs,ERd	2					
XORC	XORC #xx:8,CCR	1					
	XORC #xx:8,EXR	2					

Notes: 1. 2 when EXR is invalid, 3 when EXR is valid.
2. When n bytes of data are transferred.

A.5 Bus States During Instruction Execution

Table A-6 indicates the types of cycles that occur during instruction execution by the CPU. See table A-4 for the number of states per cycle.

How to Read the Table:

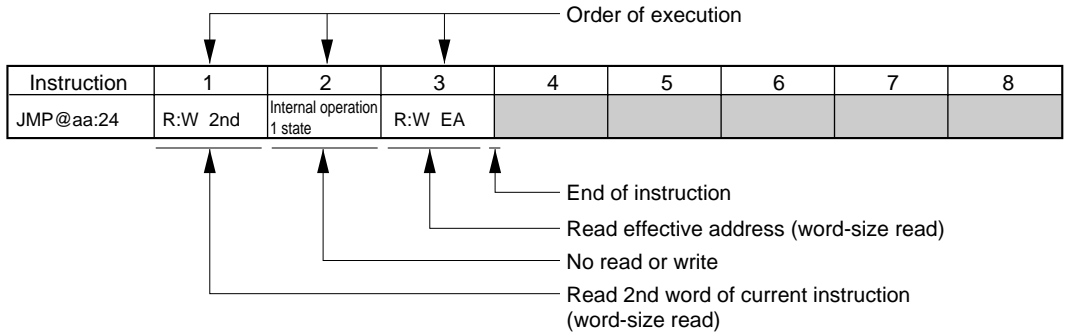

Legend

R:B	Byte-size read
R:W	Word-size read
W:B	Byte-size write
W:W	Word-size write
:M	Transfer of the bus is not performed immediately after this cycle
2nd	Address of 2nd word (3rd and 4th bytes)
3rd	Address of 3rd word (5th and 6th bytes)
4th	Address of 4th word (7th and 8th bytes)
5th	Address of 5th word (9th and 10th bytes)
NEXT	Address of next instruction
EA	Effective address
VEC	Vector address

Figure A-1 shows timing waveforms for the address bus and the \overline{RD} , \overline{HWR} , and \overline{LWR} signals during execution of the above instruction with an 8-bit bus, using three-state access with no wait states.

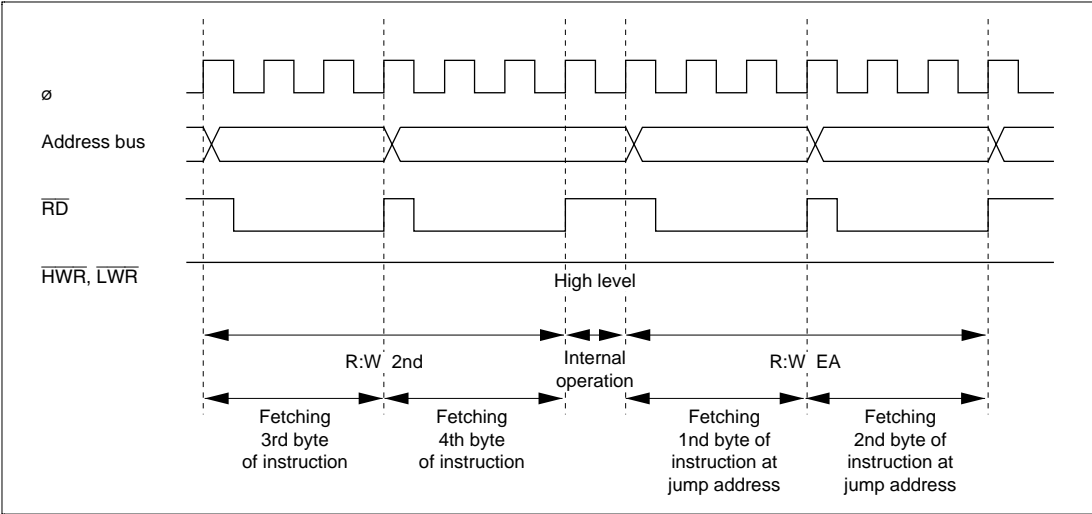

**Figure A-1 Address Bus, \overline{RD} , \overline{HWR} , and \overline{LWR} Timing
(8-Bit Bus, Three-State Access, No Wait States)**

Table A-6 Instruction Execution Cycles

Instruction	1	2	3	4	5	6	7	8	9
ADD.B #xx:8,Rd	R:W NEXT								
ADD.B Rs,Rd	R:W NEXT								
ADD.W #xx:16,Rd	R:W 2nd	R:W NEXT							
ADD.W Rs,Rd	R:W NEXT								
ADD.L #xx:32,ERd	R:W 2nd	R:W 3rd	R:W NEXT						
ADD.L ERs,ERd	R:W NEXT								
ADDS #1/2/4,ERd	R:W NEXT								
ADDX #xx:8,Rd	R:W NEXT								
ADDX Rs,Rd	R:W NEXT								
AND.B #xx:8,Rd	R:W NEXT								
AND.B Rs,Rd	R:W NEXT								
AND.W #xx:16,Rd	R:W 2nd	R:W NEXT							
AND.W Rs,Rd	R:W NEXT								
AND.L #xx:32,ERd	R:W 2nd	R:W 3rd	R:W NEXT						
AND.L ERs,ERd	R:W 2nd	R:W NEXT							
ANDC #xx:8,CCR	R:W NEXT								
ANDC #xx:8,EXR	R:W 2nd	R:W NEXT							
BAND #xx:3,Rd	R:W NEXT								
BAND #xx:3,@ERd	R:W 2nd	R:B EA	R:W:M NEXT						
BAND #xx:3,@aa:8	R:W 2nd	R:B EA	R:W:M NEXT						
BAND #xx:3,@aa:16	R:W 2nd	R:W 3rd	R:B EA	R:W:M NEXT					
BAND #xx:3,@aa:32	R:W 2nd	R:W 3rd	R:W 4th	R:B EA	R:W:M NEXT				
BRA d:8 (BT d:8)	R:W NEXT	R:W EA							
BRN d:8 (BF d:8)	R:W NEXT	R:W EA							
BHI d:8	R:W NEXT	R:W EA							
BLS d:8	R:W NEXT	R:W EA							
BCC d:8 (BHS d:8)	R:W NEXT	R:W EA							
BCS d:8 (BLO d:8)	R:W NEXT	R:W EA							
BNE d:8	R:W NEXT	R:W EA							
BEQ d:8	R:W NEXT	R:W EA							
BVC d:8	R:W NEXT	R:W EA							
BVS d:8	R:W NEXT	R:W EA							
BPL d:8	R:W NEXT	R:W EA							
BMI d:8	R:W NEXT	R:W EA							
BGE d:8	R:W NEXT	R:W EA							
BLT d:8	R:W NEXT	R:W EA							
BGT d:8	R:W NEXT	R:W EA							

Instruction	1	2	3	4	5	6	7	8	9
BLE d:8	R:W NEXT	R:W EA							
BRA d:16 (BT d:16)	R:W 2nd	Internal operation, 1 state	R:W EA						
BRN d:16 (BF d:16)	R:W 2nd	Internal operation, 1 state	R:W EA						
BHI d:16	R:W 2nd	Internal operation, 1 state	R:W EA						
BLS d:16	R:W 2nd	Internal operation, 1 state	R:W EA						
BCC d:16 (BHS d:16)	R:W 2nd	Internal operation, 1 state	R:W EA						
BCS d:16 (BLO d:16)	R:W 2nd	Internal operation, 1 state	R:W EA						
BNE d:16	R:W 2nd	Internal operation, 1 state	R:W EA						
BEQ d:16	R:W 2nd	Internal operation, 1 state	R:W EA						
BVC d:16	R:W 2nd	Internal operation, 1 state	R:W EA						
BVS d:16	R:W 2nd	Internal operation, 1 state	R:W EA						
BPL d:16	R:W 2nd	Internal operation, 1 state	R:W EA						
BMI d:16	R:W 2nd	Internal operation, 1 state	R:W EA						
BGE d:16	R:W 2nd	Internal operation, 1 state	R:W EA						
BLT d:16	R:W 2nd	Internal operation, 1 state	R:W EA						
BGT d:16	R:W 2nd	Internal operation, 1 state	R:W EA						
BLE d:16	R:W 2nd	Internal operation, 1 state	R:W EA						
BCLR #xx:3,Rd	R:W NEXT								
BCLR #xx:3,@ERd	R:W 2nd	R:B:M EA	R:W:M NEXT W:B EA						
BCLR #xx:3,@aa:8	R:W 2nd	R:B:M EA	R:W:M NEXT W:B EA						
BCLR #xx:3,@aa:16	R:W 2nd	R:W:3rd	R:B:M EA	R:W:M NEXT W:B EA					

Instruction	1	2	3	4	5	6	7	8	9
BCLR #xx:3,@aa:32	R:W 2nd	R:W 3rd	R:W 4th	R:B:MEA	R:W:M NEXT	W:B EA			
BCLR Rn,Rd	R:W NEXT								
BCLR Rn,@ERd	R:W 2nd	R:B:MEA	R:W:M NEXT	W:B EA					
BCLR Rn,@aa:8	R:W 2nd	R:B:MEA	R:W:M NEXT	W:B EA					
BCLR Rn,@aa:16	R:W 2nd	R:W 3rd	R:B:MEA	R:W:M NEXT	W:B EA				
BCLR Rn,@aa:32	R:W 2nd	R:W 3rd	R:W 4th	R:B:MEA	R:W:M NEXT	W:B EA			
BIAND #xx:3,Rd	R:W NEXT								
BIAND #xx:3,@ERd	R:W 2nd	R:B EA	R:W:M NEXT						
BIAND #xx:3,@aa:8	R:W 2nd	R:B EA	R:W:M NEXT						
BIAND #xx:3,@aa:16	R:W 2nd	R:W 3rd	R:B EA	R:W:M NEXT					
BIAND #xx:3,@aa:32	R:W 2nd	R:W 3rd	R:W 4th	R:B EA	R:W:M NEXT				
BILD #xx:3,Rd	R:W NEXT								
BILD #xx:3,@ERd	R:W 2nd	R:B EA	R:W:M NEXT						
BILD #xx:3,@aa:8	R:W 2nd	R:B EA	R:W:M NEXT						
BILD #xx:3,@aa:16	R:W 2nd	R:W 3rd	R:B EA	R:W:M NEXT					
BILD #xx:3,@aa:32	R:W 2nd	R:W 3rd	R:W 4th	R:B EA	R:W:M NEXT				
BIOR #xx:3,Rd	R:W NEXT								
BIOR #xx:3,@ERd	R:W 2nd	R:B EA	R:W:M NEXT						
BIOR #xx:3,@aa:8	R:W 2nd	R:B EA	R:W:M NEXT						
BIOR #xx:3,@aa:16	R:W 2nd	R:W 3rd	R:B EA	R:W:M NEXT					
BIOR #xx:3,@aa:32	R:W 2nd	R:W 3rd	R:W 4th	R:B EA	R:W:M NEXT				
BIST #xx:3,Rd	R:W NEXT								
BIST #xx:3,@ERd	R:W 2nd	R:B:MEA	R:W:M NEXT	W:B EA					
BIST #xx:3,@aa:8	R:W 2nd	R:B:MEA	R:W:M NEXT	W:B EA					
BIST #xx:3,@aa:16	R:W 2nd	R:W 3rd	R:B:MEA	R:W:M NEXT	W:B EA				
BIST #xx:3,@aa:32	R:W 2nd	R:W 3rd	R:W 4th	R:B:MEA	R:W:M NEXT	W:B EA			
BIXOR #xx:3,Rd	R:W NEXT								
BIXOR #xx:3,@ERd	R:W 2nd	R:B EA	R:W:M NEXT						
BIXOR #xx:3,@aa:8	R:W 2nd	R:B EA	R:W:M NEXT						
BIXOR #xx:3,@aa:16	R:W 2nd	R:W 3rd	R:B EA	R:W:M NEXT					
BIXOR #xx:3,@aa:32	R:W 2nd	R:W 3rd	R:W 4th	R:B EA	R:W:M NEXT				
BLD #xx:3,Rd	R:W NEXT								
BLD #xx:3,@ERd	R:W 2nd	R:B EA	R:W:M NEXT						
BLD #xx:3,@aa:8	R:W 2nd	R:B EA	R:W:M NEXT						
BLD #xx:3,@aa:16	R:W 2nd	R:W 3rd	R:B EA	R:W:M NEXT					
BLD #xx:3,@aa:32	R:W 2nd	R:W 3rd	R:W 4th	R:B EA	R:W:M NEXT				
BNOT #xx:3,Rd	R:W NEXT								

Instruction	1	2	3	4	5	6	7	8	9
BNOT #xx:3,@ERd	R:W 2nd	R:B:ME A	R:W:M NEXT	W:B EA					
BNOT #xx:3,@aa:8	R:W 2nd	R:B:ME A	R:W:M NEXT	W:B EA					
BNOT #xx:3,@aa:16	R:W 2nd	R:W 3rd	R:B:ME A	R:W:M NEXT	W:B EA				
BNOT #xx:3,@aa:32	R:W 2nd	R:W 3rd	R:W 4th	R:B:ME A	R:W:M NEXT	W:B EA			
BNOT Rn,Rd	R:W NEXT								
BNOT Rn,@ERd	R:W 2nd	R:B:ME A	R:W:M NEXT	W:B EA					
BNOT Rn,@aa:8	R:W 2nd	R:B:ME A	R:W:M NEXT	W:B EA					
BNOT Rn,@aa:16	R:W 2nd	R:W 3rd	R:B:ME A	R:W:M NEXT	W:B EA				
BNOT Rn,@aa:32	R:W 2nd	R:W 3rd	R:W 4th	R:B:ME A	R:W:M NEXT	W:B EA			
BOR #xx:3,Rd	R:W NEXT								
BOR #xx:3,@ERd	R:W 2nd	R:B EA	R:W:M NEXT						
BOR #xx:3,@aa:8	R:W 2nd	R:B EA	R:W:M NEXT						
BOR #xx:3,@aa:16	R:W 2nd	R:W 3rd	R:B EA	R:W:M NEXT					
BOR #xx:3,@aa:32	R:W 2nd	R:W 3rd	R:W 4th	R:B EA	R:W:M NEXT				
BSET #xx:3,Rd	R:W NEXT								
BSET #xx:3,@ERd	R:W 2nd	R:B:ME A	R:W:M NEXT	W:B EA					
BSET #xx:3,@aa:8	R:W 2nd	R:B:ME A	R:W:M NEXT	W:B EA					
BSET #xx:3,@aa:16	R:W 2nd	R:W 3rd	R:B:ME A	R:W:M NEXT	W:B EA				
BSET #xx:3,@aa:32	R:W 2nd	R:W 3rd	R:W 4th	R:B:ME A	R:W:M NEXT	W:B EA			
BSET Rn,Rd	R:W NEXT								
BSET Rn,@ERd	R:W 2nd	R:B:ME A	R:W:M NEXT	W:B EA					
BSET Rn,@aa:8	R:W 2nd	R:B:ME A	R:W:M NEXT	W:B EA					
BSET Rn,@aa:16	R:W 2nd	R:W 3rd	R:B:ME A	R:W:M NEXT	W:B EA				
BSET Rn,@aa:32	R:W 2nd	R:W 3rd	R:W 4th	R:B:ME A	R:W:M NEXT	W:B EA			
BSR d:8	Normal	R:W EA	W:W stack						
BSR d:16	Advanced	R:W EA	W:W:M stack (H)	W:W stack (L)					
	Normal	Internal operation, 1 state	R:W EA	W:W stack					
Advanced	R:W 2nd	Internal operation, 1 state	R:W EA	W:W:M stack (H)	W:W stack (L)				
		Internal operation, 1 state	R:W EA						
BST #xx:3,Rd	R:W NEXT								
BST #xx:3,@ERd	R:W 2nd	R:B:ME A	R:W:M NEXT	W:B EA					
BST #xx:3,@aa:8	R:W 2nd	R:B:ME A	R:W:M NEXT	W:B EA					
BST #xx:3,@aa:16	R:W 2nd	R:W 3rd	R:B:ME A	R:W:M NEXT	W:B EA				
BST #xx:3,@aa:32	R:W 2nd	R:W 3rd	R:W 4th	R:B:ME A	R:W:M NEXT	W:B EA			
BTST #xx:3,Rd	R:W NEXT								
BTST #xx:3,@ERd	R:W 2nd	R:B EA	R:W:M NEXT						

Instruction	1	2	3	4	5	6	7	8	9
BTST #xx:3,@aa:8	R:W 2nd	R:B EA	R:W:M NEXT						
BTST #xx:3,@aa:16	R:W 2nd	R:W 3rd	R:B EA	R:W:M NEXT					
BTST #xx:3,@aa:32	R:W 2nd	R:W 3rd	R:W 4th	R:B EA	R:W:M NEXT				
BTST Rn,Rd	R:W NEXT								
BTST Rn,@ERd	R:W 2nd	R:B EA	R:W:M NEXT						
BTST Rn,@aa:8	R:W 2nd	R:B EA	R:W:M NEXT						
BTST Rn,@aa:16	R:W 2nd	R:W 3rd	R:B EA	R:W: NEXT					
BTST Rn,@aa:32	R:W 2nd	R:W 3rd	R:W 4th	R:B EA	R:W: NEXT				
BXOR #xx:3,Rd	R:W NEXT								
BXOR #xx:3,@ERd	R:W 2nd	R:B EA	R:W:M NEXT						
BXOR #xx:3,@aa:8	R:W 2nd	R:B EA	R:W:M NEXT						
BXOR #xx:3,@aa:16	R:W 2nd	R:W 3rd	R:B EA	R:W:M NEXT					
BXOR #xx:3,@aa:32	R:W 2nd	R:W 3rd	R:W 4th	R:B EA	R:W:M NEXT				
CLRMAC	Cannot be used in the H8S/2355 Series								
CMP.B #xx:8,Rd	R:W NEXT								
CMP.B Rs,Rd	R:W NEXT								
CMP.W #xx:16,Rd	R:W 2nd	R:W NEXT							
CMP.W Rs,Rd	R:W NEXT								
CMP.L #xx:32,ERd	R:W 2nd	R:W 3rd	R:W NEXT						
CMP.L ERs,ERd	R:W NEXT								
DAA Rd	R:W NEXT								
DAS Rd	R:W NEXT								
DEC.B Rd	R:W NEXT								
DEC.W #1/2,Rd	R:W NEXT								
DECL #1/2,ERd	R:W NEXT								
DIVXS.B Rs,Rd	R:W 2nd	R:W NEXT	Internal operation, 11 states						
DIVXS.W Rs,ERd	R:W 2nd	R:W NEXT	Internal operation, 19 states						
DIVXU.B Rs,Rd	R:W NEXT	Internal operation, 11 states							
DIVXU.W Rs,ERd	R:W NEXT	Internal operation, 19 states							
EEMOV.B	R:W 2nd	R:B EAs*1	R:B EAd*1	R:B EAs*2	W:B EAd*2	R:W NEXT			
EEMOV.W	R:W 2nd	R:B EAs*1	R:B EAd*1	R:B EAs*2	W:B EAd*2	R:W NEXT			
EXTS.W Rd	R:W NEXT			← Repeated n times*2 →					
EXTS.L ERd	R:W NEXT								
EXTU.W Rd	R:W NEXT								
EXTU.L ERd	R:W NEXT								
INC.B Rd	R:W NEXT								

Instruction	1	2	3	4	5	6	7	8	9
INC.W #1/2,Rd	R:W NEXT								
INC.L #1/2,ERd	R:W NEXT								
JMP @ERn	R:W NEXT	R:W EA							
JMP @aa:24	R:W 2nd	Internal operation, 1 state	R:W EA						
JMP @@aa:8	R:W NEXT	R:W aa:8	Internal operation, 1 state	R:W EA					
	R:W NEXT	R:W:M aa:8	R:W aa:8	Internal operation, 1 state	R:W EA				
JSR @ERn	R:W NEXT	R:W EA	W:W stack						
	R:W NEXT	R:W EA	W:W:M stack (H)	W:W stack (L)					
JSR @aa:24	R:W 2nd	Internal operation, 1 state	R:W EA	W:W stack					
	R:W 2nd	Internal operation, 1 state	R:W EA	W:W:M stack (H)	W:W stack (L)				
JSR @@aa:8	R:W NEXT	R:W aa:8	W:W stack	R:W EA					
	R:W NEXT	R:W:M aa:8	R:W aa:8	W:W:M stack (H)	W:W stack (L)	R:W EA			
LDC #xx:8,CCR	R:W NEXT								
LDC #xx:8,EXR	R:W 2nd	R:W NEXT							
LDC Rs,CCR	R:W NEXT								
LDC Rs,EXR	R:W NEXT								
LDC @ERs,CCR	R:W 2nd	R:W NEXT	R:W EA						
LDC @ERs,EXR	R:W 2nd	R:W NEXT	R:W EA						
LDC @(d:16,ERs),CCR	R:W 2nd	R:W 3rd	R:W NEXT	R:W EA					
LDC @(d:16,ERs),EXR	R:W 2nd	R:W 3rd	R:W NEXT	R:W EA					
LDC @(d:32,ERs),CCR	R:W 2nd	R:W 3rd	R:W 4th	R:W 5th	R:W NEXT	R:W EA			
LDC @(d:32,ERs),EXR	R:W 2nd	R:W 3rd	R:W 4th	R:W 5th	R:W NEXT	R:W EA			
LDC @ERs+,CCR	R:W 2nd	R:W NEXT	Internal operation, 1 state	R:W EA					
LDC @ERs+,EXR	R:W 2nd	R:W NEXT	Internal operation, 1 state	R:W EA					
LDC @aa:16,CCR	R:W 2nd	R:W 3rd	R:W NEXT	R:W EA					
LDC @aa:16,EXR	R:W 2nd	R:W 3rd	R:W NEXT	R:W EA					
LDC @aa:32,CCR	R:W 2nd	R:W 3rd	R:W 4th	R:W NEXT	R:W EA				
LDC @aa:32,EXR	R:W 2nd	R:W 3rd	R:W 4th	R:W NEXT	R:W EA				
LDMLL @SP+, (ERn-ERn+1)	R:W 2nd	R:W:M NEXT	Internal operation, 1 state	R:W:M stack (H) ^{*3}	R:W stack (L) ^{*3}				

Instruction	1	2	3	4	5	6	7	8	9
LDM.L @SP+, (ERn-ERn+2)	R:W 2nd	R:W NEXT	Internal operation, 1 state	R:W:M stack (H)*3	R:W stack (L)*3				
LDM.L @SP+, (ERn-ERn+3)	R:W 2nd	R:W NEXT	Internal operation, 1 state	R:W:M stack (H)*3	R:W stack (L)*3				
LDMAC ERs, MACH									
LDMAC ERs, MACL									
MAC @ERn+, @ERm+									
MOV.B #xx:8, Rd									
MOV.B Rs, Rd									
MOV.B @ERs, Rd		R:B EA							
MOV.B @(d:16, ERs), Rd	R:W 2nd	R:W NEXT	R:B EA						
MOV.B @(d:32, ERs), Rd	R:W 2nd	R:W 3rd	R:W 4th	R:W NEXT	R:B EA				
MOV.B @ERs+, Rd	R:W NEXT	Internal operation, 1 state	R:B EA						
MOV.B @aa:8, Rd	R:W NEXT	R:B EA							
MOV.B @aa:16, Rd	R:W 2nd	R:W NEXT	R:B EA						
MOV.B @aa:32, Rd	R:W 2nd	R:W 3rd	R:W NEXT	R:B EA					
MOV.B Rs, @ERd	R:W NEXT	W:B EA							
MOV.B Rs, @(d:16, ERd)	R:W 2nd	R:W NEXT	W:B EA						
MOV.B Rs, @(d:32, ERd)	R:W 2nd	R:W 3rd	R:W 4th	R:W NEXT	W:B EA				
MOV.B Rs, @-ERd	R:W NEXT	Internal operation, 1 state	W:B EA						
MOV.B Rs, @aa:8	R:W NEXT	W:B EA							
MOV.B Rs, @aa:16	R:W 2nd	R:W NEXT	W:B EA						
MOV.B Rs, @aa:32	R:W 2nd	R:W 3rd	R:W NEXT	W:B EA					
MOV.W #xx:16, Rd	R:W 2nd	R:W NEXT							
MOV.W Rs, Rd	R:W NEXT								
MOV.W @ERs, Rd	R:W NEXT	R:W EA							
MOV.W @(d:16, ERs), Rd	R:W 2nd	R:W NEXT	R:W EA						
MOV.W @(d:32, ERs), Rd	R:W 2nd	R:W 3rd	R:W 4th	R:W NEXT	R:W EA				
MOV.W @ERs+, Rd	R:W NEXT	Internal operation, 1 state	R:W EA						
MOV.W @aa:16, Rd	R:W 2nd	R:W NEXT	R:W EA						
MOV.W @aa:32, Rd	R:W 2nd	R:W 3rd	R:W NEXT	R:B EA					
MOV.W Rs, @ERd	R:W NEXT	W:W EA							

Instruction	1	2	3	4	5	6	7	8	9
MOV.W Rs,@(d:16,ERd)	R:W 2nd	R:W NEXT	W:W EA						
MOV.W Rs,@(d:32,ERd)	R:W 2nd	R:W 3rd	R:E 4th	R:W NEXT	W:W EA				
MOV.W Rs,@-ERd	R:W NEXT	Internal operation, 1 state	W:W EA						
MOV.W Rs,@aa:16	R:W 2nd	R:W NEXT	W:W EA						
MOV.W Rs,@aa:32	R:W 2nd	R:W 3rd	R:W NEXT	W:W EA					
MOV.L #xx:32,ERd	R:W 2nd	R:W 3rd	R:W NEXT						
MOV.L ERs,ERd	R:W NEXT								
MOV.L @ERs,ERd	R:W 2nd	R:W:M NEXT	R:W: EA	R:W EA+2					
MOV.L @(d:16,ERs),ERd	R:W 2nd	R:W:M 3rd	R:W NEXT	R:W:M EA	R:W EA+2				
MOV.L @(d:32,ERs),ERd	R:W 2nd	R:W:M 3rd	R:W:M 4th	R:W 5th	R:W NEXT	R:W:M EA	R:W EA+2		
MOV.L @ERs+,ERd	R:W 2nd	R:W:M NEXT	Internal operation, 1 state	R:W:M EA	R:W EA+2				
MOV.L @aa:16,ERd	R:W 2nd	R:W:M 3rd	R:W NEXT	R:W:M EA	R:W EA+2				
MOV.L @aa:32,ERd	R:W 2nd	R:W:M 3rd	R:W 4th	R:W NEXT	R:W:M EA	R:W EA+2			
MOV.L ERs,@ERd	R:W 2nd	R:W:M NEXT	W:W: EA	W:W EA+2					
MOV.L ERs,@(d:16,ERd)	R:W 2nd	R:W:M 3rd	R:W NEXT	W:W:M EA	W:W EA+2				
MOV.L ERs,@(d:32,ERd)	R:W 2nd	R:W:M 3rd	R:W:M 4th	R:W 5th	R:W NEXT	W:W:M EA	W:W EA+2		
MOV.L ERs,@-ERd	R:W 2nd	R:W:M NEXT	Internal operation, 1 state	W:W:M EA	W:W EA+2				
MOV.L ERs,@aa:16	R:W 2nd	R:W:M 3rd	R:W NEXT	W:W:M EA	W:W EA+2				
MOV.L ERs,@aa:32	R:W 2nd	R:W:M 3rd	R:W 4th	R:W NEXT	W:W:M EA	W:W EA+2			
MOVFPPE @aa:16,Rd	Cannot be used in the H8S/2355 Series								
MOVTPPE @aa:16,Rd	Cannot be used in the H8S/2355 Series								
MULXS.B Rs,Rd	R:W 2nd	R:W NEXT	Internal operation, 11 states						
MULXS.W Rs,ERd	R:W 2nd	R:W NEXT	Internal operation, 19 states						
MULXU.B Rs,Rd	R:W NEXT	Internal operation, 11 states							
MULXU.W Rs,ERd	R:W NEXT	Internal operation, 19 states							
NEGB Rd	R:W NEXT								
NEG.W Rd	R:W NEXT								
NEGL ERd	R:W NEXT								
NOP	R:W NEXT								
NOT.B Rd	R:W NEXT								
NOT.W Rd	R:W NEXT								
NOT.L ERd	R:W NEXT								
OR.B #xx:8,Rd	R:W NEXT								
OR.B Rs,Rd	R:W NEXT								

Instruction	1	2	3	4	5	6	7	8	9
OR.W #xx:16,Rd	R:W 2nd	R:W NEXT							
OR.W Rs,Rd	R:W NEXT								
OR.L #xx:32,ERd	R:W 2nd	R:W 3rd	R:W NEXT						
OR.L ERs,ERd	R:W 2nd	R:W NEXT							
ORC #xx:8,CCR	R:W NEXT								
ORC #xx:8,EXR	R:W 2nd								
POP.W Rn	R:W NEXT	Internal operation, 1 state	R:W EA						
POP.L ERn	R:W 2nd	R:W:M NEXT	Internal operation, 1 state	R:W:M EA	R:W EA+2				
PUSH.W Rn	R:W NEXT	Internal operation, 1 state	W:W EA						
PUSH.L ERn	R:W 2nd	R:W:M NEXT	Internal operation, 1 state	W:W:M EA	W:W EA+2				
ROTL.B Rd	R:W NEXT								
ROTL.B #2,Rd	R:W NEXT								
ROTL.W Rd	R:W NEXT								
ROTL.W #2,Rd	R:W NEXT								
ROTL.L ERd	R:W NEXT								
ROTL.L #2,ERd	R:W NEXT								
ROTR.B Rd	R:W NEXT								
ROTR.B #2,Rd	R:W NEXT								
ROTR.W Rd	R:W NEXT								
ROTR.W #2,Rd	R:W NEXT								
ROTR.L ERd	R:W NEXT								
ROTR.L #2,ERd	R:W NEXT								
ROTXL.B Rd	R:W NEXT								
ROTXL.B #2,Rd	R:W NEXT								
ROTXL.W Rd	R:W NEXT								
ROTXL.W #2,Rd	R:W NEXT								
ROTXL.L ERd	R:W NEXT								
ROTXL.L #2,ERd	R:W NEXT								
ROTXR.B Rd	R:W NEXT								
ROTXR.B #2,Rd	R:W NEXT								
ROTXR.W Rd	R:W NEXT								
ROTXR.W #2,Rd	R:W NEXT								
ROTXR.L ERd	R:W NEXT								

Instruction	1	2	3	4	5	6	7	8	9
ROTXR:L #2,ERd	R:W NEXT	R:W stack (EXR)	R:W stack (H)	R:W stack (L)	Internal operation, 1 state	R:W ^{#:4}			
RTE	R:W NEXT	R:W stack	R:W stack (H)	R:W stack (L)	Internal operation, 1 state	R:W ^{#:4}			
RTS	Normal	R:W stack	Internal operation, 1 state	R:W ^{#:4}					
	Advanced	R:W stack (H)	R:W stack (L)	Internal operation, 1 state	R:W ^{#:4}				
SHAL.B Rd	R:W NEXT								
SHAL.B #2,Rd	R:W NEXT								
SHAL.W Rd	R:W NEXT								
SHAL.W #2,Rd	R:W NEXT								
SHAL.L ERd	R:W NEXT								
SHAL.L #2,ERd	R:W NEXT								
SHAR.B Rd	R:W NEXT								
SHAR.B #2,Rd	R:W NEXT								
SHAR.W Rd	R:W NEXT								
SHAR.W #2,Rd	R:W NEXT								
SHAR.L ERd	R:W NEXT								
SHAR.L #2,ERd	R:W NEXT								
SHLL.B Rd	R:W NEXT								
SHLL.B #2,Rd	R:W NEXT								
SHLL.W Rd	R:W NEXT								
SHLL.W #2,Rd	R:W NEXT								
SHLL.L ERd	R:W NEXT								
SHLL.L #2,ERd	R:W NEXT								
SHLR.B Rd	R:W NEXT								
SHLR.B #2,Rd	R:W NEXT								
SHLR.W Rd	R:W NEXT								
SHLR.W #2,Rd	R:W NEXT								
SHLR.L ERd	R:W NEXT								
SHLR.L #2,ERd	R:W NEXT								
SLEEP	R:W NEXT	Internal operation:M							
STC CCR,Rd	R:W NEXT								
STC EXR,Rd	R:W NEXT								
STC CCR,@ERd	R:W 2nd	R:W NEXT	W:W EA						
STC EXR,@ERd	R:W 2nd	R:W NEXT	W:W EA						
STC CCR,@(d:16,ERd)	R:W 2nd	R:W 3rd	R:W NEXT	W:W EA					

Instruction	1	2	3	4	5	6	7	8	9
STC EXR,@(d:16,ERd)	R:W 2nd	R:W 3rd	R:W NEXT	W:W EA					
STC CCR,@(d:32,ERd)	R:W 2nd	R:W 3rd	R:W 4th	R:W 5th	R:W NEXT	W:W EA			
STC EXR,@(d:32,ERd)	R:W 2nd	R:W 3rd	R:W 4th	R:W 5th	R:W NEXT	W:W EA			
STC CCR,@-ERd	R:W 2nd	R:W NEXT	Internal operation, 1 state	W:W EA					
STC EXR,@-ERd	R:W 2nd	R:W NEXT	Internal operation, 1 state	W:W EA					
STC CCR,@aa:16	R:W 2nd	R:W 3rd	R:W NEXT	W:W EA					
STC EXR,@aa:16	R:W 2nd	R:W 3rd	R:W NEXT	W:W EA					
STC CCR,@aa:32	R:W 2nd	R:W 3rd	R:W 4th	R:W NEXT	W:W EA				
STC EXR,@aa:32	R:W 2nd	R:W 3rd	R:W 4th	R:W NEXT	W:W EA				
STM.L(ERn-ERn+1),@-SP	R:W 2nd	R:W:M NEXT	Internal operation, 1 state	W:W:M stack (H) ^{*3}	W:W stack (L) ^{*3}				
STM.L(ERn-ERn+2),@-SP	R:W 2nd	R:W:M NEXT	Internal operation, 1 state	W:W:M stack (H) ^{*3}	W:W stack (L) ^{*3}				
STM.L(ERn-ERn+3),@-SP	R:W 2nd	R:W:M NEXT	Internal operation, 1 state	W:W:M stack (H) ^{*3}	W:W stack (L) ^{*3}				

Cannot be used in the H8S/2355 Series

STMAC MACH,ERd									
STMAC MACL,ERd									
SUB.B Rs,Rd	R:W NEXT								
SUB.W #xx:16,Rd	R:W 2nd	R:W NEXT							
SUB.W Rs,Rd	R:W NEXT								
SUB.L #xx:32,ERd	R:W 2nd	R:W 3rd	R:W NEXT						
SUB.L ERs,ERd	R:W NEXT								
SUBS #1/2/4,ERd	R:W NEXT								
SUBX #xx:8,Rd	R:W NEXT								
SUBX Rs,Rd	R:W NEXT								
TAS @ERd	R:W 2nd	R:W NEXT	R:B:M EA	W:B EA					
TRAPA #x:2	Normal	Internal operation, 1 state	W:W stack (L)	W:W stack (H)	W:W stack (EXR)	R:W VEC	Internal operation, 1 state	R:W ^{*7}	
	Advanced	Internal operation, 1 state	W:W stack (L)	W:W stack (H)	W:W stack (EXR)	R:W:M VEC	R:W VEC+2	Internal operation, 1 state	R:W ^{*7}
XOR.B #xx:8,Rd	R:W NEXT								
XOR.B Rs,Rd	R:W NEXT								
XOR.W #xx:16,Rd	R:W 2nd	R:W NEXT							
XOR.W Rs,Rd	R:W NEXT								
XOR.L #xx:32,ERd	R:W 2nd	R:W 3rd	R:W NEXT						

Instruction	1	2	3	4	5	6	7	8	9
XOR.L ERs,ERd	R:W 2nd	R:W NEXT							
XORC #xx:8,CCR	R:W NEXT								
XORC #xx:8,EXR	R:W 2nd	R:W NEXT							
Reset exception handling	R:W VEC	Internal operation, 1 state	R:W ^{n:5}						
Interrupt exception handling	R:W VEC	R:W VEC+2	Internal operation, 1 state	R:W ^{n:5}					
	R:W ^{n:6}	Internal operation, 1 state	W:W stack (L)	W:W stack (H)	W:W stack (EXR)	R:W VEC	Internal operation, 1 state	R:W ^{n:7}	
	R:W ^{n:6}	Internal operation, 1 state	W:W stack (L)	W:W stack (H)	W:W stack (EXR)	R:W:M VEC	R:W VEC+2	Internal operation, 1 state	R:W ^{n:7}

Notes: 1. EAs is the contents of ER5. EAd is the contents of ER6.

2. EAs is the contents of ER5. EAd is the contents of ER6. Both registers are incremented by 1 after execution of the instruction. n is the initial value of R4L or R4. If n = 0, these bus cycles are not executed.

3. Repeated two times to save or restore two registers, three times for three registers, or four times for four registers.

4. Start address after return.

5. Start address of the program.

6. Prefetch address, equal to two plus the PC value pushed onto the stack. In recovery from sleep mode or software standby mode the read operation is replaced by an internal operation.

7. Start address of the interrupt-handling routine.

A.6 Condition Code Modification

This section indicates the effect of each CPU instruction on the condition code. The notation used in the table is defined below.

$$m = \begin{cases} 31 & \text{for longword operands} \\ 15 & \text{for word operands} \\ 7 & \text{for byte operands} \end{cases}$$

S_i The i -th bit of the source operand

D_i The i -th bit of the destination operand

R_i The i -th bit of the result

D_n The specified bit in the destination operand

— Not affected

\updownarrow Modified according to the result of the instruction (see definition)

0 Always cleared to 0

1 Always set to 1

* Undetermined (no guaranteed value)

Z' Z flag before instruction execution

C' C flag before instruction execution

Table A-7 Condition Code Modification

Instruction	H	N	Z	V	C	Definition
ADD	↑	↑	↑	↑	↑	$H = S_{m-4} \cdot D_{m-4} + D_{m-4} \cdot \overline{R_{m-4}} + S_{m-4} \cdot \overline{R_{m-4}}$ $N = R_m$ $Z = \overline{R_m} \cdot \overline{R_{m-1}} \cdot \dots \cdot \overline{R_0}$ $V = S_m \cdot D_m \cdot \overline{R_m} + \overline{S_m} \cdot \overline{D_m} \cdot R_m$ $C = S_m \cdot D_m + D_m \cdot \overline{R_m} + S_m \cdot \overline{R_m}$
ADDS	—	—	—	—	—	
ADDX	↑	↑	↑	↑	↑	$H = S_{m-4} \cdot D_{m-4} + D_{m-4} \cdot \overline{R_{m-4}} + S_{m-4} \cdot \overline{R_{m-4}}$ $N = R_m$ $Z = Z' \cdot \overline{R_m} \cdot \dots \cdot \overline{R_0}$ $V = S_m \cdot D_m \cdot \overline{R_m} + \overline{S_m} \cdot \overline{D_m} \cdot R_m$ $C = S_m \cdot D_m + D_m \cdot \overline{R_m} + S_m \cdot \overline{R_m}$
AND	—	↑	↑	0	—	$N = R_m$ $Z = \overline{R_m} \cdot \overline{R_{m-1}} \cdot \dots \cdot \overline{R_0}$
ANDC	↑	↑	↑	↑	↑	Stores the corresponding bits of the result. No flags change when the operand is EXR.
BAND	—	—	—	—	↑	$C = C' \cdot D_n$
Bcc	—	—	—	—	—	
BCLR	—	—	—	—	—	
BIAND	—	—	—	—	↑	$C = C' \cdot \overline{D_n}$
BILD	—	—	—	—	↑	$C = \overline{D_n}$
BIOR	—	—	—	—	↑	$C = C' + \overline{D_n}$
BIST	—	—	—	—	—	
BIXOR	—	—	—	—	↑	$C = C' \cdot D_n + \overline{C'} \cdot \overline{D_n}$
BLD	—	—	—	—	↑	$C = D_n$
BNOT	—	—	—	—	—	
BOR	—	—	—	—	↑	$C = C' + D_n$
BSET	—	—	—	—	—	
BSR	—	—	—	—	—	
BST	—	—	—	—	—	
BTST	—	—	↑	—	—	$Z = \overline{D_n}$
BXOR	—	—	—	—	↑	$C = C' \cdot \overline{D_n} + \overline{C'} \cdot D_n$
CLRMAC						Cannot be used in the H8S/2355 Series

Instruction	H	N	Z	V	C	Definition
CMP	↑	↑	↑	↑	↑	$H = S_{m-4} \cdot \overline{D_{m-4}} + \overline{D_{m-4}} \cdot R_{m-4} + S_{m-4} \cdot R_{m-4}$ $N = R_m$ $Z = \overline{R_m} \cdot \overline{R_{m-1}} \cdot \dots \cdot \overline{R_0}$ $V = \overline{S_m} \cdot D_m \cdot \overline{R_m} + S_m \cdot \overline{D_m} \cdot R_m$ $C = S_m \cdot \overline{D_m} + \overline{D_m} \cdot R_m + S_m \cdot R_m$
DAA	*	↑	↑	*	↑	$N = R_m$ $Z = \overline{R_m} \cdot \overline{R_{m-1}} \cdot \dots \cdot \overline{R_0}$ C: decimal arithmetic carry
DAS	*	↑	↑	*	↑	$N = R_m$ $Z = \overline{R_m} \cdot \overline{R_{m-1}} \cdot \dots \cdot \overline{R_0}$ C: decimal arithmetic borrow
DEC	—	↑	↑	↑	—	$N = R_m$ $Z = \overline{R_m} \cdot \overline{R_{m-1}} \cdot \dots \cdot \overline{R_0}$ $V = D_m \cdot \overline{R_m}$
DIVXS	—	↑	↑	—	—	$N = S_m \cdot \overline{D_m} + \overline{S_m} \cdot D_m$ $Z = \overline{S_m} \cdot \overline{S_{m-1}} \cdot \dots \cdot \overline{S_0}$
DIVXU	—	↑	↑	—	—	$N = S_m$ $Z = \overline{S_m} \cdot \overline{S_{m-1}} \cdot \dots \cdot \overline{S_0}$
EEPMOV	—	—	—	—	—	
EXTS	—	↑	↑	0	—	$N = R_m$ $Z = \overline{R_m} \cdot \overline{R_{m-1}} \cdot \dots \cdot \overline{R_0}$
EXTU	—	0	↑	0	—	$Z = \overline{R_m} \cdot \overline{R_{m-1}} \cdot \dots \cdot \overline{R_0}$
INC	—	↑	↑	↑	—	$N = R_m$ $Z = \overline{R_m} \cdot \overline{R_{m-1}} \cdot \dots \cdot \overline{R_0}$ $V = \overline{D_m} \cdot R_m$
JMP	—	—	—	—	—	
JSR	—	—	—	—	—	
LDC	↑	↑	↑	↑	↑	Stores the corresponding bits of the result. No flags change when the operand is EXR.
LDM	—	—	—	—	—	
LDMAC	Cannot be used in the H8S/2355 Series					
MAC						

Instruction	H	N	Z	V	C	Definition
MOV	—	↓	↓	0	—	N = Rm Z = $\overline{Rm} \cdot \overline{Rm-1} \cdot \dots \cdot \overline{R0}$
MOVFPPE	Can not be used in the H8S/2355 Series					
MOVTPE						
MULXS	—	↓	↓	—	—	N = R2m Z = $\overline{R2m} \cdot \overline{R2m-1} \cdot \dots \cdot \overline{R0}$
MULXU	—	—	—	—	—	
NEG	↓	↓	↓	↓	↓	H = Dm-4 + Rm-4 N = Rm Z = $\overline{Rm} \cdot \overline{Rm-1} \cdot \dots \cdot \overline{R0}$ V = Dm · Rm C = Dm + Rm
NOP	—	—	—	—	—	
NOT	—	↓	↓	0	—	N = Rm Z = $\overline{Rm} \cdot \overline{Rm-1} \cdot \dots \cdot \overline{R0}$
OR	—	↓	↓	0	—	N = Rm Z = $\overline{Rm} \cdot \overline{Rm-1} \cdot \dots \cdot \overline{R0}$
ORC	↓	↓	↓	↓	↓	Stores the corresponding bits of the result. No flags change when the operand is EXR.
POP	—	↓	↓	0	—	N = Rm Z = $\overline{Rm} \cdot \overline{Rm-1} \cdot \dots \cdot \overline{R0}$
PUSH	—	↓	↓	0	—	N = Rm Z = $\overline{Rm} \cdot \overline{Rm-1} \cdot \dots \cdot \overline{R0}$
ROTL	—	↓	↓	0	↓	N = Rm Z = $\overline{Rm} \cdot \overline{Rm-1} \cdot \dots \cdot \overline{R0}$ C = Dm (1-bit shift) or C = Dm-1 (2-bit shift)
ROTR	—	↓	↓	0	↓	N = Rm Z = $\overline{Rm} \cdot \overline{Rm-1} \cdot \dots \cdot \overline{R0}$ C = D0 (1-bit shift) or C = D1 (2-bit shift)

Instruction	H	N	Z	V	C	Definition
ROTXL	—	↓	↓	0	↓	$N = R_m$ $Z = \overline{R_m} \cdot \overline{R_{m-1}} \cdot \dots \cdot \overline{R_0}$ $C = D_m$ (1-bit shift) or $C = D_{m-1}$ (2-bit shift)
ROTXR	—	↓	↓	0	↓	$N = R_m$ $Z = \overline{R_m} \cdot \overline{R_{m-1}} \cdot \dots \cdot \overline{R_0}$ $C = D_0$ (1-bit shift) or $C = D_1$ (2-bit shift)
RTE	↓	↓	↓	↓	↓	Stores the corresponding bits of the result.
RTS	—	—	—	—	—	
SHAL	—	↓	↓	↓	↓	$N = R_m$ $Z = \overline{R_m} \cdot \overline{R_{m-1}} \cdot \dots \cdot \overline{R_0}$ $V = \overline{D_m} \cdot \overline{D_{m-1}} + \overline{D_m} \cdot \overline{D_{m-1}}$ (1-bit shift) $V = \overline{D_m} \cdot \overline{D_{m-1}} \cdot \overline{D_{m-2}} \cdot \overline{D_m} \cdot \overline{D_{m-1}} \cdot \overline{D_{m-2}}$ (2-bit shift) $C = D_m$ (1-bit shift) or $C = D_{m-1}$ (2-bit shift)
SHAR	—	↓	↓	0	↓	$N = R_m$ $Z = \overline{R_m} \cdot \overline{R_{m-1}} \cdot \dots \cdot \overline{R_0}$ $C = D_0$ (1-bit shift) or $C = D_1$ (2-bit shift)
SHLL	—	↓	↓	0	↓	$N = R_m$ $Z = \overline{R_m} \cdot \overline{R_{m-1}} \cdot \dots \cdot \overline{R_0}$ $C = D_m$ (1-bit shift) or $C = D_{m-1}$ (2-bit shift)
SHLR	—	0	↓	0	↓	$N = R_m$ $Z = \overline{R_m} \cdot \overline{R_{m-1}} \cdot \dots \cdot \overline{R_0}$ $C = D_0$ (1-bit shift) or $C = D_1$ (2-bit shift)
SLEEP	—	—	—	—	—	
STC	—	—	—	—	—	
STM	—	—	—	—	—	
STMAC						Cannot be used in the H8S/2355 Series

Instruction	H	N	Z	V	C	Definition
SUB	↑	↑	↑	↑	↑	$H = S_{m-4} \cdot \overline{D_{m-4}} + \overline{D_{m-4}} \cdot R_{m-4} + S_{m-4} \cdot R_{m-4}$ $N = R_m$ $Z = \overline{R_m} \cdot \overline{R_{m-1}} \cdot \dots \cdot \overline{R_0}$ $V = \overline{S_m} \cdot D_m \cdot \overline{R_m} + S_m \cdot \overline{D_m} \cdot R_m$ $C = S_m \cdot \overline{D_m} + \overline{D_m} \cdot R_m + S_m \cdot R_m$
SUBS	—	—	—	—	—	
SUBX	↑	↑	↑	↑	↑	$H = S_{m-4} \cdot \overline{D_{m-4}} + \overline{D_{m-4}} \cdot R_{m-4} + S_{m-4} \cdot R_{m-4}$ $N = R_m$ $Z = Z' \cdot \overline{R_m} \cdot \dots \cdot \overline{R_0}$ $V = \overline{S_m} \cdot D_m \cdot \overline{R_m} + S_m \cdot \overline{D_m} \cdot R_m$ $C = S_m \cdot \overline{D_m} + \overline{D_m} \cdot R_m + S_m \cdot R_m$
TAS	—	↑	↑	0	—	$N = D_m$ $Z = \overline{D_m} \cdot \overline{D_{m-1}} \cdot \dots \cdot \overline{D_0}$
TRAPA	—	—	—	—	—	
XOR	—	↑	↑	0	—	$N = R_m$ $Z = \overline{R_m} \cdot \overline{R_{m-1}} \cdot \dots \cdot \overline{R_0}$
XORC	↑	↑	↑	↑	↑	Stores the corresponding bits of the result. No flags change when the operand is EXR.

Appendix B Internal I/O Register

B.1 Addresses

Address (low)	Register Name	Bit 7	Bit 6	Bit 5	Bit 4	Bit 3	Bit 2	Bit 1	Bit 0	Module Name	Data Bus Width
H'F800	MRA	SM1	SM0	DM1	DM0	MD1	MD0	DTS	Sz	DTC	16/32* ¹ bit
to	SAR										
H'FBFF											
	MRB	CHNE	DISEL	—	—	—	—	—	—		
	DAR										
	CRA										
	CRB										
H'FE80	TCR3	CCLR2	CCLR1	CCLR0	CKEG1	CKEG0	TPSC2	TPSC1	TPSC0	TPU3	16 bit
H'FE81	TMDR3	—	—	BFB	BFA	MD3	MD2	MD1	MD0		
H'FE82	TIOR3H	IOB3	IOB2	IOB1	IOB0	IOA3	IOA2	IOA1	IOA0		
H'FE83	TIOR3L	IOD3	IOD2	IOD1	IOD0	IOC3	IOC2	IOC1	IOC0		
H'FE84	TIER3	TTGE	—	—	TCIEV	TGIED	TGIEC	TGIEB	TGIEA		
H'FE85	TSR3	—	—	—	TCFV	TGFD	TGFC	TGFB	TGFA		
H'FE86	TCNT3										
H'FE87											
H'FE88	TGR3A										
H'FE89											
H'FE8A	TGR3B										
H'FE8B											
H'FE8C	TGR3C										
H'FE8D											
H'FE8E	TGR3D										
H'FE8F											

Address (low)	Register Name	Bit 7	Bit 6	Bit 5	Bit 4	Bit 3	Bit 2	Bit 1	Bit 0	Module Name	Data Bus Width
H'FE90	TCR4	—	CCLR1	CCLR0	CKEG1	CKEG0	TPSC2	TPSC1	TPSC0	TPU4	16 bit
H'FE91	TMDR4	—	—	—	—	MD3	MD2	MD1	MD0		
H'FE92	TIOR4	IOB3	IOB2	IOB1	IOB0	IOA3	IOA2	IOA1	IOA0		
H'FE94	TIER4	TTGE	—	TCIEU	TCIEV	—	—	TGIEB	TGIEA		
H'FE95	TSR4	TCFD	—	TCFU	TCFV	—	—	TGFB	TGFA		
H'FE96	TCNT4										
H'FE97											
H'FE98	TGR4A										
H'FE99											
H'FE9A	TGR4B										
H'FE9B											
H'FEA0	TCR5	—	CCLR1	CCLR0	CKEG1	CKEG0	TPSC2	TPSC1	TPSC0	TPU5	16 bit
H'FEA1	TMDR5	—	—	—	—	MD3	MD2	MD1	MD0		
H'FEA2	TIOR5	IOB3	IOB2	IOB1	IOB0	IOA3	IOA2	IOA1	IOA0		
H'FEA4	TIER5	TTGE	—	TCIEU	TCIEV	—	—	TGIEB	TGIEA		
H'FEA5	TSR5	TCFD	—	TCFU	TCFV	—	—	TGFB	TGFA		
H'FEA6	TCNT5										
H'FEA7											
H'FEA8	TGR5A										
H'FEA9											
H'FEAA	TGR5B										
H'FEAB											
H'FEB0	P1DDR	P17DDR	P16DDR	P15DDR	P14DDR	P13DDR	P12DDR	P11DDR	P10DDR	Port	8 bit
H'FEB1	P2DDR	P27DDR	P26DDR	P25DDR	P24DDR	P23DDR	P22DDR	P21DDR	P20DDR		
H'FEB2	P3DDR	—	—	P35DDR	P34DDR	P33DDR	P32DDR	P31DDR	P30DDR		
H'FEB4	P5DDR	—	—	—	—	P53DDR	P52DDR	P51DDR	P50DDR		
H'FEB5	P6DDR	P67DDR	P66DDR	P65DDR	P64DDR	P63DDR	P62DDR	P61DDR	P60DDR		
H'FEB9	PADDR	PA7DDR	PA6DDR	PA5DDR	PA4DDR	PA3DDR	PA2DDR	PA1DDR	PA0DDR		
H'FEBA	PBDDR	PB7DDR	PB6DDR	PB5DDR	PB4DDR	PB3DDR	PB2DDR	PB1DDR	PB0DDR		
H'FEBB	PCDDR	PC7DDR	PC6DDR	PC5DDR	PC4DDR	PC3DDR	PC2DDR	PC1DDR	PC0DDR		
H'FEBC	PDDDR	PD7DDR	PD6DDR	PD5DDR	PD4DDR	PD3DDR	PD2DDR	PD1DDR	PD0DDR		
H'FEBD	PEDDR	PE7DDR	PE6DDR	PE5DDR	PE4DDR	PE3DDR	PE2DDR	PE1DDR	PE0DDR		
H'FEBE	PFDDR	PF7DDR	PF6DDR	PF5DDR	PF4DDR	PF3DDR	PF2DDR	PF1DDR	PF0DDR		
H'FEBF	PGDDR	—	—	—	PG4DDR	PG3DDR	PG2DDR	PG1DDR	PG0DDR		

Address (low)	Register Name	Bit 7	Bit 6	Bit 5	Bit 4	Bit 3	Bit 2	Bit 1	Bit 0	Module Name	Data Bus Width		
H'FEC4	IPRA	—	IPR6	IPR5	IPR4	—	IPR2	IPR1	IPR0	Interrupt controller	8 bit		
H'FEC5	IPRB	—	IPR6	IPR5	IPR4	—	IPR2	IPR1	IPR0				
H'FEC6	IPRC	—	IPR6	IPR5	IPR4	—	IPR2	IPR1	IPR0				
H'FEC7	IPRD	—	IPR6	IPR5	IPR4	—	IPR2	IPR1	IPR0				
H'FEC8	IPRE	—	IPR6	IPR5	IPR4	—	IPR2	IPR1	IPR0				
H'FEC9	IPRF	—	IPR6	IPR5	IPR4	—	IPR2	IPR1	IPR0				
H'FECA	IPRG	—	IPR6	IPR5	IPR4	—	IPR2	IPR1	IPR0				
H'FECB	IPRH	—	IPR6	IPR5	IPR4	—	IPR2	IPR1	IPR0				
H'FECC	IPRI	—	IPR6	IPR5	IPR4	—	IPR2	IPR1	IPR0				
H'FECD	IPRJ	—	IPR6	IPR5	IPR4	—	IPR2	IPR1	IPR0				
H'FECE	IPRK	—	IPR6	IPR5	IPR4	—	IPR2	IPR1	IPR0				
H'FED0	ABWCR	ABW7	ABW6	ABW5	ABW4	ABW3	ABW2	ABW1	ABW0	Bus controller	8 bit		
H'FED1	ASTCR	AST7	AST6	AST5	AST4	AST3	AST2	AST1	AST0				
H'FED2	WCRH	W71	W70	W61	W60	W51	W50	W41	W40				
H'FED3	WCRL	W31	W30	W21	W20	W11	W10	W01	W00				
H'FED4	BCRH	ICIS1	ICIS0	BRSTRM	BRSTS1	BRSTS0	—	—	—				
H'FED5	BCRL	BRLE	—	EAE	—	—	—	—	WAITE				
H'FF2C	ISCRH	IRQ7SCB	IRQ7SCA	IRQ6SCB	IRQ6SCA	IRQ5SCB	IRQ5SCA	IRQ4SCB	IRQ4SCA			Interrupt controller	8 bit
H'FF2D	ISCR L	IRQ3SCB	IRQ3SCA	IRQ2SCB	IRQ2SCA	IRQ1SCB	IRQ1SCA	IRQ0SCB	IRQ0SCA				
H'FF2E	IER	IRQ7E	IRQ6E	IRQ5E	IRQ4E	IRQ3E	IRQ2E	IRQ1E	IRQ0E				
H'FF2F	ISR	IRQ7F	IRQ6F	IRQ5F	IRQ4F	IRQ3F	IRQ2F	IRQ1F	IRQ0F				
H'FF30 to H'FF35	DTCER	DTCE7	DTCE6	DTCE5	DTCE4	DTCE3	DTCE2	DTCE1	DTCE0	DTC	8 bit		
H'FF37	DTVECR	SWDTE	DTVEC6	DTVEC5	DTVEC4	DTVEC3	DTVEC2	DTVEC1	DTVEC0				
H'FF38	SBYCR	SSBY	STS2	STS1	STS0	OPE	—	—	—	Power-down mode	8 bit		
H'FF39	SYSCR	—	—	INTM1	INTM0	NMIEG	—	—	RAME	MCU	8 bit		
H'FF3A	SCKCR	PSTOP	—	—	—	—	SCK2	SCK1	SCK0	Clock pulse generator	8 bit		
H'FF3B	MDCR	—	—	—	—	—	MDS2	MDS1	MDS0	MCU	8 bit		
H'FF3C	MSTPCR H	MSTP15	MSTP14	MSTP13	MSTP12	MSTP11	MSTP10	MSTP9	MSTP8	Power-down mode	8 bit		
H'FF3D	MSTPCR L	MSTP7	MSTP6	MSTP5	MSTP4	MSTP3	MSTP2	MSTP1	MSTP0				
H'FF44	Reserved	—	—	—	—	—	—	—	—	Reserved	—		

Address (low)	Register Name	Bit 7	Bit 6	Bit 5	Bit 4	Bit 3	Bit 2	Bit 1	Bit 0	Module Name	Data Bus Width
H'FF50	PORT1	P17	P16	P15	P14	P13	P12	P11	P10	Port	8 bit
H'FF51	PORT2	P27	P26	P25	P24	P23	P22	P21	P20		
H'FF52	PORT3	—	—	P35	P34	P33	P32	P31	P30		
H'FF53	PORT4	P47	P46	P45	P44	P43	P42	P41	P40		
H'FF54	PORT5	—	—	—	—	P53	P52	P51	P50		
H'FF55	PORT6	P67	P66	P65	P64	P63	P62	P61	P60		
H'FF59	PORTA	PA7	PA6	PA5	PA4	PA3	PA2	PA1	PA0		
H'FF5A	PORTB	PB7	PB6	PB5	PB4	PB3	PB2	PB1	PB0		
H'FF5B	PORTC	PC7	PC6	PC5	PC4	PC3	PC2	PC1	PC0		
H'FF5C	PORTD	PD7	PD6	PD5	PD4	PD3	PD2	PD1	PD0		
H'FF5D	PORTE	PE7	PE6	PE5	PE4	PE3	PE2	PE1	PE0		
H'FF5E	PORTF	PF7	PF6	PF5	PF4	PF3	PF2	PF1	PF0		
H'FF5F	PORTG	—	—	—	PG4	PG3	PG2	PG1	PG0		
H'FF60	P1DR	P17DR	P16DR	P15DR	P14DR	P13DR	P12DR	P11DR	P10DR		
H'FF61	P2DR	P27DR	P26DR	P25DR	P24DR	P23DR	P22DR	P21DR	P20DR		
H'FF62	P3DR	—	—	P35DR	P34DR	P33DR	P32DR	P31DR	P30DR		
H'FF64	P5DR	—	—	—	—	P53DR	P52DR	P51DR	P50DR		
H'FF65	P6DR	P67DR	P66DR	P65DR	P64DR	P63DR	P62DR	P61DR	P60DR		
H'FF69	PADR	PA7DR	PA6DR	PA5DR	PA4DR	PA3DR	PA2DR	PA1DR	PA0DR		
H'FF6A	PBDR	PB7DR	PB6DR	PB5DR	PB4DR	PB3DR	PB2DR	PB1DR	PB0DR		
H'FF6B	PCDR	PC7DR	PC6DR	PC5DR	PC4DR	PC3DR	PC2DR	PC1DR	PC0DR		
H'FF6C	PDDR	PD7DR	PD6DR	PD5DR	PD4DR	PD3DR	PD2DR	PD1DR	PD0DR		
H'FF6D	PEDR	PE7DR	PE6DR	PE5DR	PE4DR	PE3DR	PE2DR	PE1DR	PE0DR		
H'FF6E	PFDR	PF7DR	PF6DR	PF5DR	PF4DR	PF3DR	PF2DR	PF1DR	PF0DR		
H'FF6F	PGDR	—	—	—	PG4DR	PG3DR	PG2DR	PG1DR	PG0DR		
H'FF70	PAPCR	PA7PCR	PA6PCR	PA5PCR	PA4PCR	PA3PCR	PA2PCR	PA1PCR	PA0PCR		
H'FF71	PBPCR	PB7PCR	PB6PCR	PB5PCR	PB4PCR	PB3PCR	PB2PCR	PB1PCR	PB0PCR		
H'FF72	PCPCR	PC7PCR	PC6PCR	PC5PCR	PC4PCR	PC3PCR	PC2PCR	PC1PCR	PC0PCR		
H'FF73	PDPCR	PD7PCR	PD6PCR	PD5PCR	PD4PCR	PD3PCR	PD2PCR	PD1PCR	PD0PCR		
H'FF74	PEPCR	PE7PCR	PE6PCR	PE5PCR	PE4PCR	PE3PCR	PE2PCR	PE1PCR	PE0PCR		
H'FF76	P3ODR	—	—	P35ODR	P34ODR	P33ODR	P32ODR	P31ODR	P30ODR		
H'FF77	PAODR	PA7ODR	PA6ODR	PA5ODR	PA4ODR	PA3ODR	PA2ODR	PA1ODR	PA0ODR		

Address (low)	Register Name	Bit 7	Bit 6	Bit 5	Bit 4	Bit 3	Bit 2	Bit 1	Bit 0	Module Name	Data Bus Width
H'FF78	SMR0	C/ \bar{A} / GM* ²	CHR	PE	O/ \bar{E}	STOP	MP	CKS1	CKS0	SCI0, Smart card interface 0	8 bit
H'FF79	BRR0										
H'FF7A	SCR0	TIE	RIE	TE	RE	MPIE	TEIE	CKE1	CKE0		
H'FF7B	TDR0										
H'FF7C	SSR0	TDRE	RDRF	ORER	FER/ ERS* ³	PER	TEND	MPB	MPBT		
H'FF7D	RDR0										
H'FF7E	SCMR0	—	—	—	—	SDIR	SINV	—	SMIF		
H'FF80	SMR1	C/ \bar{A} / GM* ²	CHR	PE	O/ \bar{E}	STOP	MP	CKS1	CKS0	SCI1, Smart card interface 1	8 bit
H'FF81	BRR1										
H'FF82	SCR1	TIE	RIE	TE	RE	MPIE	TEIE	CKE1	CKE0		
H'FF83	TDR1										
H'FF84	SSR1	TDRE	RDRF	ORER	FER/ ERS* ³	PER	TEND	MPB	MPBT		
H'FF85	RDR1										
H'FF86	SCMR1	—	—	—	—	SDIR	SINV	—	SMIF		
H'FF88	SMR2	C/ \bar{A} / GM* ²	CHR	PE	O/ \bar{E}	STOP	MP	CKS1	CKS0	SCI2, Smart card interface 2	8 bit
H'FF89	BRR2										
H'FF8A	SCR2	TIE	RIE	TE	RE	MPIE	TEIE	CKE1	CKE0		
H'FF8B	TDR2										
H'FF8C	SSR2	TDRE	RDRF	ORER	FER/ ERS* ³	PER	TEND	MPB	MPBT		
H'FF8D	RDR2										
H'FF8E	SCMR2	—	—	—	—	SDIR	SINV	—	SMIF		
H'FF90	ADDRAH	AD9	AD8	AD7	AD6	AD5	AD4	AD3	AD2	A/D converter	8 bit
H'FF91	ADDRAL	AD1	AD0	—	—	—	—	—	—		
H'FF92	ADDRBH	AD9	AD8	AD7	AD6	AD5	AD4	AD3	AD2		
H'FF93	ADDRBL	AD1	AD0	—	—	—	—	—	—		
H'FF94	ADDRCH	AD9	AD8	AD7	AD6	AD5	AD4	AD3	AD2		
H'FF95	ADDRCL	AD1	AD0	—	—	—	—	—	—		
H'FF96	ADDRDH	AD9	AD8	AD7	AD6	AD5	AD4	AD3	AD2		
H'FF97	ADDRDL	AD1	AD0	—	—	—	—	—	—		
H'FF98	ADCSR	ADF	ADIE	ADST	SCAN	CKS	—	CH1	CH0		
H'FF99	ADCR	TRGS1	TRGS0	—	—	—	—	—	—		

Address (low)	Register Name	Bit 7	Bit 6	Bit 5	Bit 4	Bit 3	Bit 2	Bit 1	Bit 0	Module Name	Data Bus Width
H'FFA4	DADR0* ⁴									D/A converter* ⁴	8 bit
H'FFA5	DADR1* ⁴										
H'FFA6	DACR* ⁴	DAOE1	DAOE0	DAE	—	—	—	—	—		
H'FFB0	TCR0	CMIEB	CMIEA	OVIE	CCLR1	CCLR0	CKS2	CKS1	CKS0	8-bit timer channel 0, 1	16 bit
H'FFB1	TCR1	CMIEB	CMIEA	OVIE	CCLR1	CCLR0	CKS2	CKS1	CKS0		
H'FFB2	TCSR0	CMFB	CMFA	OVF	ADTE	OS3	OS2	OS1	OS0		
H'FFB3	TCSR1	CMFB	CMFA	OVF	—	OS3	OS2	OS1	OS0		
H'FFB4	TCORA0										
H'FFB5	TCORA1										
H'FFB6	TCORB0										
H'FFB7	TCORB1										
H'FFB8	TCNT0										
H'FFB9	TCNT1										
H'FFBC (read)	TCSR	OVF	WT/IT	TME	—	—	CKS2	CKS1	CKS0	WDT	16 bit
H'FFBD (read)	TCNT										
H'FFBF (read)	RSTCSR	WOVF	RSTE	RSTS	—	—	—	—	—		
H'FFC0	TSTR	—	—	CST5	CST4	CST3	CST2	CST1	CST0	TPU	16 bit
H'FFC1	TSYR	—	—	SYNC5	SYNC4	SYNC3	SYNC2	SYNC1	SYNC0		
H'FFD0	TCR0	CCLR2	CCLR1	CCLR0	CKEG1	CKEG0	TPSC2	TPSC1	TPSC0	TPU0	16 bit
H'FFD1	TMDR0	—	—	BFB	BFA	MD3	MD2	MD1	MD0		
H'FFD2	TIOR0H	IOB3	IOB2	IOB1	IOB0	IOA3	IOA2	IOA1	IOA0		
H'FFD3	TIOR0L	IOD3	IOD2	IOD1	IOD0	IOC3	IOC2	IOC1	IOC0		
H'FFD4	TIER0	TTGE	—	—	TCIEV	TGIED	TGIEC	TGIEB	TGIEA		
H'FFD5	TSR0	—	—	—	TCFV	TGFD	TGFC	TGFB	TGFA		
H'FFD6	TCNT0										
H'FFD7											
H'FFD8	TGR0A										
H'FFD9											
H'FFDA	TGR0B										
H'FFDB											
H'FFDC	TGR0C										
H'FFDD											
H'FFDE	TGR0D										
H'FFDF											

Address (low)	Register Name	Bit 7	Bit 6	Bit 5	Bit 4	Bit 3	Bit 2	Bit 1	Bit 0	Module Name	Data Bus Width
H'FFE0	TCR1	—	CCLR1	CCLR0	CKEG1	CKEG0	TPSC2	TPSC1	TPSC0	TPU1	16 bit
H'FFE1	TMDR1	—	—	—	—	MD3	MD2	MD1	MD0		
H'FFE2	TIOR1	IOB3	IOB2	IOB1	IOB0	IOA3	IOA2	IOA1	IOA0		
H'FFE4	TIER1	TTGE	—	TCIEU	TCIEV	—	—	TGIEB	TGIEA		
H'FFE5	TSR1	TCFD	—	TCFU	TCFV	—	—	TGFB	TGFA		
H'FFE6	TCNT1										
H'FFE7											
H'FFE8	TGR1A										
H'FFE9											
H'FFEA	TGR1B										
H'FFEB											
H'FFF0	TCR2	—	CCLR1	CCLR0	CKEG1	CKEG0	TPSC2	TPSC1	TPSC0	TPU2	16 bit
H'FFF1	TMDR2	—	—	—	—	MD3	MD2	MD1	MD0		
H'FFF2	TIOR2	IOB3	IOB2	IOB1	IOB0	IOA3	IOA2	IOA1	IOA0		
H'FFF4	TIER2	TTGE	—	TCIEU	TCIEV	—	—	TGIEB	TGIEA		
H'FFF5	TSR2	TCFD	—	TCFU	TCFV	—	—	TGFB	TGFA		
H'FFF6	TCNT2										
H'FFF7											
H'FFF8	TGR2A										
H'FFF9											
H'FFFA	TGR2B										
H'FFFB											

- Notes:
1. Located in on-chip RAM. The bus width is 32 bits when the DTC accesses this area as register information, and 16 bits otherwise.
 2. Functions as C/ \bar{A} for SCI use, and as GM for smart card interface use.
 3. Functions as FER for SCI use, and as ERS for smart card interface use.
 4. In the H8S/2393 these bits are reserved, as a D/A converter is not supported.

B.2 Functions

MRA—DTC Mode Register A

H'F800—H'FBFF

DTC

Bit	:	7	6	5	4	3	2	1	0
		SM1	SM0	DM1	DM0	MD1	MD0	DTS	Sz

Initial value : Undefined Undefined Undefined Undefined Undefined Undefined Undefined Undefined

Read/Write : — — — — — — — —

DTC Data
Transfer Size

0	Byte-size transfer
1	Word-size transfer

DTC Transfer Mode Select

0	Destination side is repeat area or block area
1	Source side is repeat area or block area

DTC Mode

0	0	Normal mode
	1	Repeat mode
1	0	Block transfer mode
	1	—

Destination Address Mode

0	—	DAR is fixed
1	0	DAR is incremented after a transfer (by +1 when Sz = 0; by +2 when Sz = 1)
	1	DAR is decremented after a transfer (by -1 when Sz = 0; by -2 when Sz = 1)

Source Address Mode

0	—	SAR is fixed
1	0	SAR is incremented after a transfer (by +1 when Sz = 0; by +2 when Sz = 1)
	1	SAR is decremented after a transfer (by -1 when Sz = 0; by -2 when Sz = 1)

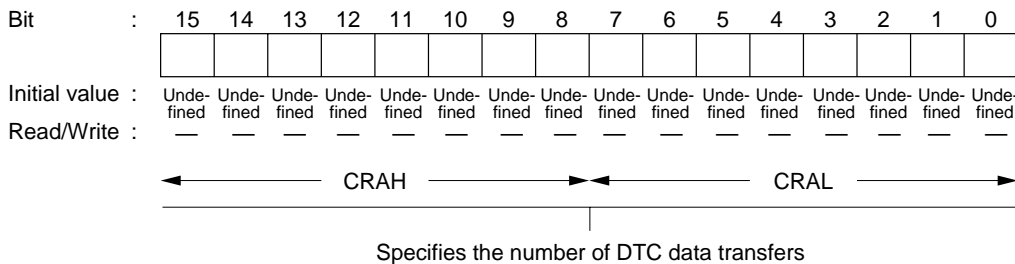

CRB—DTC Transfer Count Register B

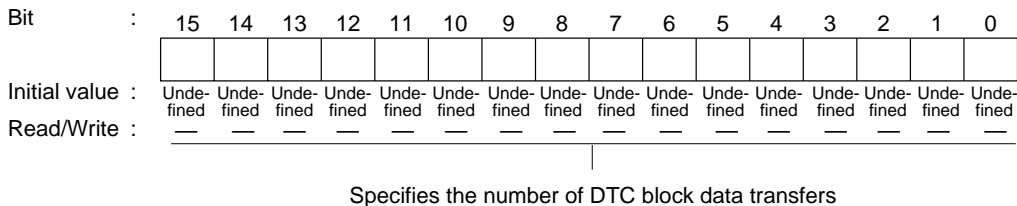

Bit	:	7	6	5	4	3	2	1	0
		CCLR2	CCLR1	CCLR0	CKEG1	CKEG0	TPSC2	TPSC1	TPSC0
Initial value	:	0	0	0	0	0	0	0	0
Read/Write	:	R/W	R/W	R/W	R/W	R/W	R/W	R/W	R/W

Timer Prescaler

0	0	0	Internal clock: counts on $\phi/1$
		1	Internal clock: counts on $\phi/4$
	1	0	Internal clock: counts on $\phi/16$
		1	Internal clock: counts on $\phi/64$
1	0	0	External clock: counts on TCLKA pin input
		1	Internal clock: counts on $\phi/1024$
	1	0	Internal clock: counts on $\phi/256$
		1	Internal clock: counts on $\phi/4096$

Clock Edge

0	0	Count at rising edge
	1	Count at falling edge
1	—	Count at both edges

Counter Clear

0	0	0	TCNT clearing disabled
		1	TCNT cleared by TGRA compare match/input capture
	1	0	TCNT cleared by TGRB compare match/input capture
		1	TCNT cleared by counter clearing for another channel performing synchronous clearing/synchronous operation *1
1	0	0	TCNT clearing disabled
		1	TCNT cleared by TGRC compare match/input capture *2
	1	0	TCNT cleared by TGRD compare match/input capture *2
		1	TCNT cleared by counter clearing for another channel performing synchronous clearing/synchronous operation *1

- Notes: 1. Synchronous operation setting is performed by setting the SYNC bit in TSYR to 1.
 2. When TGRC or TGRD is used as a buffer register, TCNT is not cleared because the buffer register setting has priority, and compare match/input capture does not occur.

Bit	:	7	6	5	4	3	2	1	0
		—	—	BFB	BFA	MD3	MD2	MD1	MD0
Initial value	:	1	1	0	0	0	0	0	0
Read/Write	:	—	—	R/W	R/W	R/W	R/W	R/W	R/W

Mode

0	0	0	0	Normal operation
		1	Reserved	
	1	0	0	PWM mode 1
		1	0	PWM mode 2
	1	0	0	Phase counting mode 1
			1	Phase counting mode 2
		1	0	Phase counting mode 3
			1	Phase counting mode 4
1	*	*	*	—

* : Don't care

- Notes: 1. MD3 is a reserved bit. In a write, it should always be written with 0.
 2. Phase counting mode cannot be set for channels 0 and 3. In this case, 0 should always be written to MD2.

Buffer Operation A

0	TGRA operates normally
1	TGRA and TGRC used together for buffer operation

Buffer Operation B

0	TGRB operates normally
1	TGRB and TGRD used together for buffer operation

Bit	:	7	6	5	4	3	2	1	0
Initial value	:	IOB3	IOB2	IOB1	IOB0	IOA3	IOA2	IOA1	IOA0
		0	0	0	0	0	0	0	0
Read/Write	:	R/W	R/W	R/W	R/W	R/W	R/W	R/W	R/W

TGR3A I/O Control

0	0	0	0	TGR3A is output compare register	Output disabled			
					1	0 output at compare match		
					0	1 output at compare match		
		1	Toggle output at compare match					
		1	0		0	TGR3A is input capture register	Output disabled	
							1	0 output at compare match
	0			1 output at compare match				
	1		0	0	Initial output is 1 output			
					1		0 output at compare match	
					0		1 output at compare match	
	1	0	0	TGR3A is input capture register	Capture input source is TIOCA3 pin			
					1	Input capture at rising edge		
0					Input capture at falling edge			
1		*	*		Capture input source is channel 4/count clock			
					1	Input capture at both edges		
					0	Input capture at TCNT4 count-up/count-down		

* : Don't care

TGR3B I/O Control

0	0	0	0	TGR3B is output compare register	Output disabled			
					1	0 output at compare match		
					0	1 output at compare match		
		1	0		0	TGR3B is input capture register	Output disabled	
							1	0 output at compare match
							0	1 output at compare match
	1		0	0	Initial output is 1 output			
					1		0 output at compare match	
					0		1 output at compare match	
	1	0	0	TGR3B is input capture register	Capture input source is TIOCB3 pin			
					1	Input capture at rising edge		
					0	Input capture at falling edge		
1		*	*		Capture input source is channel 4/count clock			
					1	Input capture at both edges		
					0	Input capture at TCNT4 count-up/count-down		

* : Don't care

Note: 1. If bits TPSC2 to TPSC0 in TCR4 are set to B'000, and 0/1 is used as the TCNT4 count clock, this setting will be invalid and input capture will not occur.

Bit	:	7	6	5	4	3	2	1	0
		IOD3	IOD2	IOD1	IOD0	IOC3	IOC2	IOC1	IOC0
Initial value	:	0	0	0	0	0	0	0	0
Read/Write	:	R/W	R/W	R/W	R/W	R/W	R/W	R/W	R/W

TRG3C I/O Control

0	0	0	0	0	TGR3C is output compare register	Output disabled			
						1	0	Initial output is 0 output	0 output at compare match
								1 output at compare match	
						1	0	Toggle output at compare match	
	Output disabled								
	1	0	0	0	1	TGR3C is output compare register	Initial output is 1 output	0 output at compare match	
								1 output at compare match	
							1	0	Toggle output at compare match
Output disabled									
1	0	0	0	1	TGR3C is input capture register	Capture input source is TIOCC3 pin	Input capture at rising edge		
							Input capture at falling edge		
							Input capture at both edges		
						1	*	*	Capture input source is channel 4/count clock

* : Don't care

Note: When the BFA bit in TMDR3 is set to 1 and TGR3C is used as a buffer register, this setting is invalid and input capture/output compare is not generated.

TGR3D I/O Control

0	0	0	0	0	TGR3D is output compare register*2	Output disabled								
						1	0	Initial output is 0 output	0 output at compare match					
									1 output at compare match					
								1	Toggle output at compare match					
						1	0	0	0	1	TGR3D is output compare register*2	Output disabled		
												1	0	Initial output is 1 output
	1 output at compare match													
	1	Toggle output at compare match												
	1	0	0	0	1							TGR3D is input capture register*2	Capture input source is TIOCD3 pin	Input capture at rising edge
														Input capture at falling edge
						Input capture at both edges								
						1	*	*	Capture input source is channel 4/count clock	Input capture at TCNT4 count-up/count-down*1				

* : Don't care

- Notes:
- 1 When bits TPSC2 to TPSC0 in TCR4 are set to B'000 and $\theta/1$ is used as the TCNT4 count clock, this setting is invalid and input capture is not generated.
 - 2 When the BFB bit in TMDR3 is set to 1 and TGR3D is used as a buffer register, this setting is invalid and input capture/output compare is not generated.

Note: When TGRC or TGRD is designated for buffer operation, this setting is invalid and the register operates as a buffer register.

Bit	:	7	6	5	4	3	2	1	0
		TTGE	—	—	TCIEV	TGIED	TGIEC	TGIEB	TGIEA
Initial value	:	0	1	0	0	0	0	0	0
Read/Write	:	R/W	—	—	R/W	R/W	R/W	R/W	R/W

TGR Interrupt Enable A

0	Interrupt requests (TGIA) by TGFA bit disabled
1	Interrupt requests (TGIA) by TGFA bit enabled

TGR Interrupt Enable B

0	Interrupt requests (TGIB) by TGFB bit disabled
1	Interrupt requests (TGIB) by TGFB bit enabled

TGR Interrupt Enable C

0	Interrupt requests (TGIC) by TGFC bit disabled
1	Interrupt requests (TGIC) by TGFC bit enabled

TGR Interrupt Enable D

0	Interrupt requests (TGID) by TGFD bit disabled
1	Interrupt requests (TGID) by TGFD bit enabled

Overflow Interrupt Enable

0	Interrupt requests (TCIV) by TCFV disabled
1	Interrupt requests (TCIV) by TCFV enabled

A/D Conversion Start Request Enable

0	A/D conversion start request generation disabled
1	A/D conversion start request generation enabled

Bit	7	6	5	4	3	2	1	0
	—	—	—	TCFV	TGFD	TGFC	TGFB	TGFA
Initial value	1	1	0	0	0	0	0	0
Read/Write	—	—	—	R/(W)*	R/(W)*	R/(W)*	R/(W)*	R/(W)*

Input Capture/Output Compare Flag A

0	[Clearing condition] • When DTC is activated by TGIA interrupt while DISEL bit of MRB in DTC is 0 • When 0 is written to TGFA after reading TGFA = 1
1	[Setting condition] • When TCNT=TGRA while TGRA is functioning as output compare register • When TCNT value is transferred to TGRA by input capture signal while TGRA is functioning as input capture register

Input Capture/Output Compare Flag B

0	[Clearing condition] • When DTC is activated by TGIB interrupt while DISEL bit of MRB in DTC is 0 • When 0 is written to TGFB after reading TGFB = 1
1	[Setting condition] • When TCNT = TGRB while TGRB is functioning as output compare register • When TCNT value is transferred to TGRB by input capture signal while TGRB is functioning as input capture register

Input Capture/Output Compare Flag C

0	[Clearing condition] • When DTC is activated by TGIC interrupt while DISEL bit of MRB in DTC is 0 • When 0 is written to TGFC after reading TGFC = 1
1	[Setting condition] • When TCNT = TGRC while TGRC is functioning as output compare register • When TCNT value is transferred to TGRC by input capture signal while TGRC is functioning as input capture register

Input Capture/Output Compare Flag D

0	[Clearing condition] • When DTC is activated by TGID interrupt while DISEL bit of MRB in DTC is 0 • When 0 is written to TGFD after reading TGFD = 1
1	[Setting condition] • When TCNT = TGRD while TGRD is functioning as output compare register • When TCNT value is transferred to TGRD by input capture signal while TGRD is functioning as input capture register

Overflow Flag

0	[Clearing condition] When 0 is written to TCFV after reading TCFV = 1
1	[Setting condition] When the TCNT value overflows (changes from H'FFFF to H'0000)

Note: * Can only be written with 0 for flag clearing.

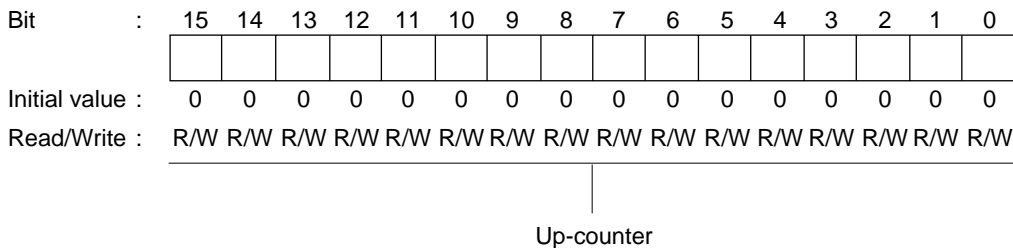

TGR3A—Timer General Register 3A

H'FE88

TPU3

TGR3B—Timer General Register 3B

H'FE8A

TPU3

TGR3C—Timer General Register 3C

H'FE8C

TPU3

TGR3D—Timer General Register 3D

H'FE8E

TPU3

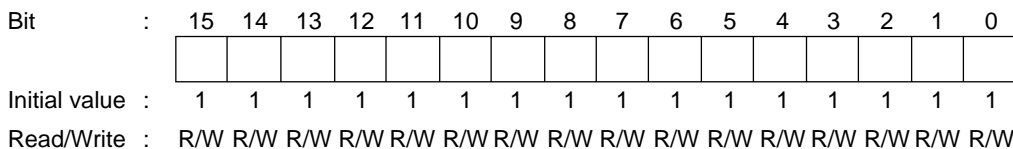

Bit	:	7	6	5	4	3	2	1	0
		—	CCLR1	CCLR0	CKEG1	CKEG0	TPSC2	TPSC1	TPSC0
Initial value	:	0	0	0	0	0	0	0	0
Read/Write	:	—	R/W	R/W	R/W	R/W	R/W	R/W	R/W

Timer Prescaler

0	0	0	Internal clock: counts on $\phi/1$
		1	Internal clock: counts on $\phi/4$
	1	0	Internal clock: counts on $\phi/16$
		1	Internal clock: counts on $\phi/64$
1	0	0	External clock: counts on TCLKA pin input
		1	External clock: counts on TCLKC pin input
	1	0	Internal clock: counts on $\phi/1024$
		1	Counts on TCNT5 overflow/underflow

Note: This setting is ignored when channel 4 is in phase counting mode.

Clock Edge

0	0	Count at rising edge
	1	Count at falling edge
1	—	Count at both edges

Note: This setting is ignored when channel 4 is in phase counting mode.

Counter Clear

0	0	TCNT clearing disabled
	1	TCNT cleared by TGRA compare match/input capture
1	0	TCNT cleared by TGRB compare match/input capture
	1	TCNT cleared by counter clearing for another channel performing synchronous clearing/synchronous operation*

Note: * Synchronous operating setting is performed by setting the SYNC bit TSYR to 1.

Bit	:	7	6	5	4	3	2	1	0
		—	—	—	—	MD3	MD2	MD1	MD0
Initial value	:	1	1	0	0	0	0	0	0
Read/Write	:	—	—	—	—	R/W	R/W	R/W	R/W

Mode

0	0	0	0	Normal operation
		1	Reserved	
	1	0	PWM mode 1	
		1	PWM mode 2	
	1	0	0	Phase counting mode 1
			1	Phase counting mode 2
		1	0	Phase counting mode 3
			1	Phase counting mode 4
1	*	*	*	—

* : Don't care

Notes: MD3 is a reserved bit. In a write, it should always be written with 0.

Bit	:	7	6	5	4	3	2	1	0
		IOB3	IOB2	IOB1	IOB0	IOA3	IOA2	IOA1	IOA0
Initial value	:	0	0	0	0	0	0	0	0
Read/Write	:	R/W	R/W	R/W	R/W	R/W	R/W	R/W	R/W

TGR4A I/O Control

0	0	0	0	TGR4A is output compare register	Output disabled		
			1		Initial output is 0 output	0 output at compare match	
			0			1 output at compare match	
		1	Toggle output at compare match				
		1	0		0	Output disabled	
					1	Initial output is 1 output	0 output at compare match
	0			1 output at compare match			
	1	Toggle output at compare match					
	1	0	0	0	TGR4A is input capture register	Capture input source is TIOCA4 pin	Input capture at rising edge
				1			Input capture at falling edge
				*			Input capture at both edges
		1	*	*		Capture input source is TGR3A compare match/input capture	Input capture at generation of TGR3A compare match/input capture

* : Don't care

TGR4B I/O Control

0	0	0	0	TGR4B is output compare register	Output disabled		
			1		Initial output is 0 output	0 output at compare match	
			0			1 output at compare match	
		1	Toggle output at compare match				
		1	0		0	Output disabled	
					1	Initial output is 1 output	0 output at compare match
	0			1 output at compare match			
	1	Toggle output at compare match					
	1	0	0	0	TGR4B is input capture register	Capture input source is TIOCB4 pin	Input capture at rising edge
				1			Input capture at falling edge
				*			Input capture at both edges
		1	*	*		Capture input source is TGR3C compare match/input capture	Input capture at generation of TGR3C compare match/input capture

* : Don't care

Bit	:	7	6	5	4	3	2	1	0
		TTGE	—	TCIEU	TCIEV	—	—	TGIEB	TGIEA
Initial value :		0	1	0	0	0	0	0	0
Read/Write :		R/W	—	R/W	R/W	—	—	R/W	R/W

TGR Interrupt Enable A

0	Interrupt requests (TGIA) by TGFA bit disabled
1	Interrupt requests (TGIA) by TGFA bit enabled

TGR Interrupt Enable B

0	Interrupt requests (TGIB) by TGFB bit disabled
1	Interrupt requests (TGIB) by TGFB bit enabled

Overflow Interrupt Enable

0	Interrupt requests (TCIV) by TCFV disabled
1	Interrupt requests (TCIV) by TCFV enabled

Underflow Interrupt Enable

0	Interrupt requests (TCIU) by TCFU disabled
1	Interrupt requests (TCIU) by TCFU enabled

A/D Conversion Start Request Enable

0	A/D conversion start request generation disabled
1	A/D conversion start request generation enabled

Bit	7	6	5	4	3	2	1	0
	TCFD	—	TCFU	TCFV	—	—	TGFB	TGFA
Initial value	1	1	0	0	0	0	0	0
Read/Write	R	—	R/(W)*	R/(W)*	—	—	R/(W)*	R/(W)*

Input Capture/Output Compare Flag A

0	[Clearing condition] • When DTC is activated by TGIA interrupt while DISEL bit of MRB in DTC is 0 • When 0 is written to TGFA after reading TGFA = 1
1	[Setting conditions] • When TCNT = TGRA while TGRA is functioning as output compare register • When TCNT value is transferred to TGRA by input capture signal while TGRA is functioning as input capture register

Input Capture/Output Compare Flag B

0	[Clearing condition] • When DTC is activated by TGIB interrupt while DISEL bit of MRB in DTC is 0 • When 0 is written to TGFB after reading TGFB = 1
1	[Setting conditions] • When TCNT = TGRB while TGRB is functioning as output compare register • When TCNT value is transferred to TGRB by input capture signal while TGRB is functioning as input capture register

Overflow Flag

0	[Clearing condition] When 0 is written to TCFV after reading TCFV = 1
1	[Setting conditions] When the TCNT value overflows (changes from H'FFFF to H'0000)

Underflow Flag

0	[Clearing condition] When 0 is written to TCFU after reading TCFU = 1
1	[Setting conditions] When the TCNT value underflows (changes from H'0000 to H'FFFF)

Count Direction Flag

0	TCNT counts down
1	TCNT counts up

Note: * Can only be written with 0 for flag clearing.

Bit	:	15	14	13	12	11	10	9	8	7	6	5	4	3	2	1	0
Initial value	:	0	0	0	0	0	0	0	0	0	0	0	0	0	0	0	0
Read/Write	:	R/W	R/W	R/W	R/W	R/W	R/W	R/W	R/W	R/W	R/W	R/W	R/W	R/W	R/W	R/W	R/W

Up/down-counter*

Note: * This timer counter can be used as an up/down-counter only in phase counting mode or when performing overflow/underflow counting on another channel. In other cases it functions as an up-counter.

TGR4A—Timer General Register 4A

TGR4B—Timer General Register 4B

Bit	:	15	14	13	12	11	10	9	8	7	6	5	4	3	2	1	0
Initial value	:	1	1	1	1	1	1	1	1	1	1	1	1	1	1	1	1
Read/Write	:	R/W	R/W	R/W	R/W	R/W	R/W	R/W	R/W	R/W	R/W	R/W	R/W	R/W	R/W	R/W	R/W

Bit	:	7	6	5	4	3	2	1	0
		—	CCLR1	CCLR0	CKEG1	CKEG0	TPSC2	TPSC1	TPSC0
Initial value	:	0	0	0	0	0	0	0	0
Read/Write	:	—	R/W	R/W	R/W	R/W	R/W	R/W	R/W

Time Prescaler

0	0	0	Internal clock: counts on $\phi/1$
		1	Internal clock: counts on $\phi/4$
	1	0	Internal clock: counts on $\phi/16$
		1	Internal clock: counts on $\phi/64$
1	0	0	External clock: counts on TCLKA pin input
		1	External clock: counts on TCLKC pin input
	1	0	Internal clock: counts on $\phi/256$
		1	External clock: counts on TCLKD pin input

Note: This setting is ignored when channel 5 is in phase counting mode.

Clock Edge

0	0	Count at rising edge
	1	Count at falling edge
1	—	Count at both edges

Note: This setting is ignored when channel 5 is in phase counting mode.

Counter Clear

0	0	TCNT clearing disabled
	1	TCNT cleared by TGRA compare match/input capture
1	0	TCNT cleared by TGRB compare match/input capture
	1	TCNT cleared by counter clearing for another channel performing synchronous clearing/synchronous operation*

Note: * Synchronous operating setting is performed by setting the SYNC bit TSYR to 1.

Bit	:	7	6	5	4	3	2	1	0
		—	—	—	—	MD3	MD2	MD1	MD0
Initial value	:	1	1	0	0	0	0	0	0
Read/Write	:	—	—	—	—	R/W	R/W	R/W	R/W

Mode

0	0	0	0	Normal operation
		1	Reserved	
		1	0	PWM mode 1
			1	PWM mode 2
	1	0	0	Phase counting mode 1
			1	Phase counting mode 2
		1	0	Phase counting mode 3
			1	Phase counting mode 4
1	*	*	*	—

*: Don't care

Notes: MD3 is a reserved bit. In a write, it should always be written with 0.

Bit	:	7	6	5	4	3	2	1	0
		IOB3	IOB2	IOB1	IOB0	IOA3	IOA2	IOA1	IOA0
Initial value	:	0	0	0	0	0	0	0	0
Read/Write	:	R/W	R/W	R/W	R/W	R/W	R/W	R/W	R/W

TGR5A I/O Control

0	0	0	0	TGR5A is output compare register	Output disabled				
					1	0	Initial output is 0 output	0 output at compare match	
							1 output at compare match		
		1	0		0	Toggle output at compare match			
						1	0	Output disabled	
								1	0
	1	0	1 output at compare match						
			1	0	Toggle output at compare match				
	1	*			0	0	TGR5A is input capture register	Capture input source is TIOCA5 pin	Input capture at rising edge
			1	*					Input capture at falling edge
									1

* : Don't care

TGR5B I/O Control

0	0	0	0	TGR5B is output compare register	Output disabled				
					1	0	0	Initial output is 0 output	0 output at compare match
								1 output at compare match	
		1	0		0	Toggle output at compare match			
						1	0	Output disabled	
								1	0
	1	0	1 output at compare match						
			1	0	Toggle output at compare match				
	1	*			0	0	TGR5B is input capture register	Capture input source is TIOCB5 pin	Input capture at rising edge
			1	*					Input capture at falling edge
									1

* : Don't care

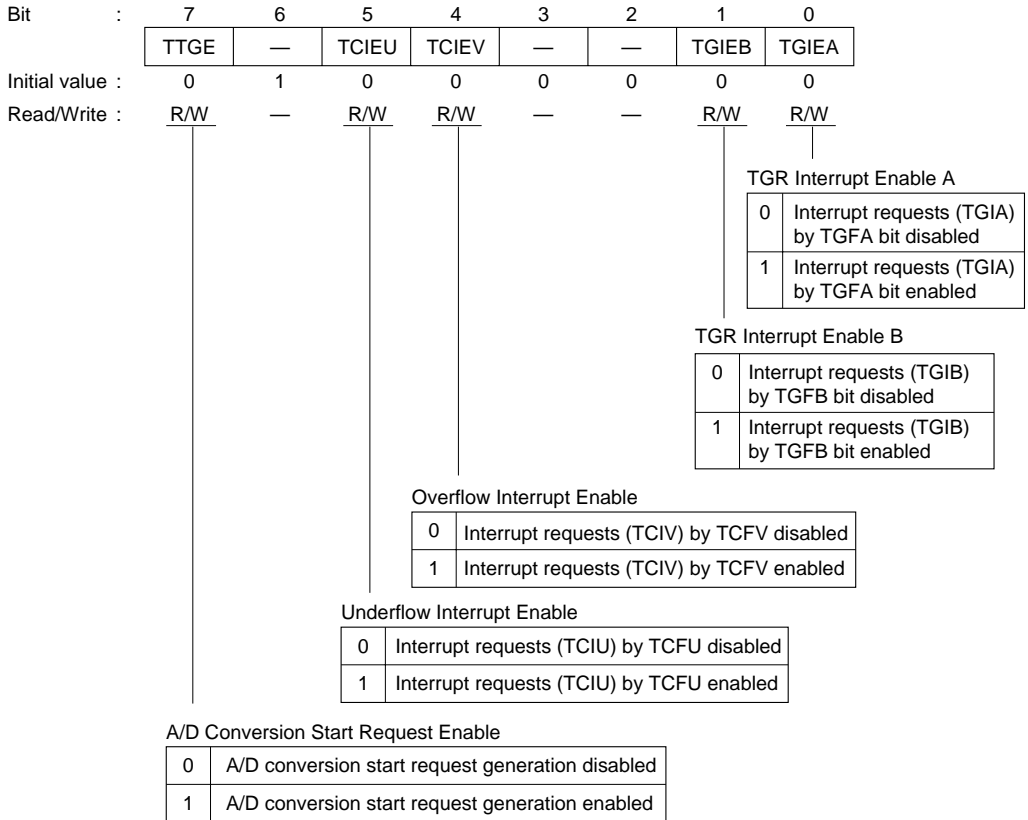

Bit	7	6	5	4	3	2	1	0
	TCFD	—	TCFU	TCFV	—	—	TGFB	TGFA
Initial value	1	1	0	0	0	0	0	0
Read/Write	R	—	R/(W)*	R/(W)*	—	—	R/(W)*	R/(W)*

Input Capture/Output Compare Flag A

0	[Clearing condition] • When DTC is activated by TGIA interrupt while DISEL bit of MRB in DTC is 0 • When 0 is written to TGFA after reading TGFA = 1
1	[Setting conditions] • When TCNT = TGRA while TGRA is functioning as output compare register • When TCNT value is transferred to TGRA by input capture signal while TGRA is functioning as input capture register

Input Capture/Output Compare Flag B

0	[Clearing condition] • When DTC is activated by TGIB interrupt while DISEL bit of MRB in DTC is 0 • When 0 is written to TGFB after reading TGFB = 1
1	[Setting conditions] • When TCNT = TGRB while TGRB is functioning as output compare register • When TCNT value is transferred to TGRB by input capture signal while TGRB is functioning as input capture register

Overflow Flag

0	[Clearing condition] When 0 is written to TCFV after reading TCFV = 1
1	[Setting conditions] When the TCNT value overflows (changes from H'FFFF to H'0000)

Underflow Flag

0	[Clearing condition] When 0 is written to TCFU after reading TCFU = 1
1	[Setting conditions] When the TCNT value underflows (changes from H'0000 to H'FFFF)

Count Direction Flag

0	TCNT counts down
1	TCNT counts up

Note: * Can only be written with 0 for flag clearing.

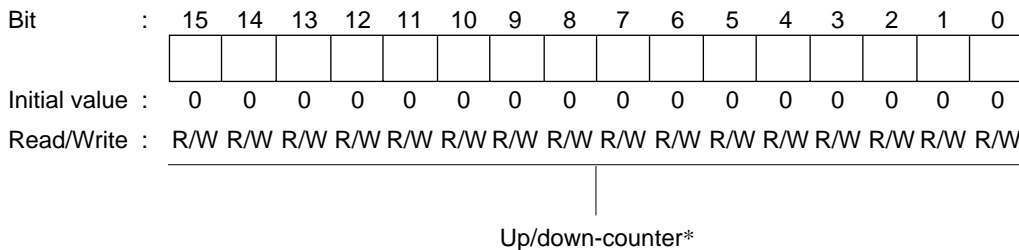

Note: * This timer counter can be used as an up/down-counter only in phase counting mode or when performing overflow/underflow counting on another channel. In other cases it functions as an up-counter.

TGR5A—Timer General Register 5A

TGR5B—Timer General Register 5B

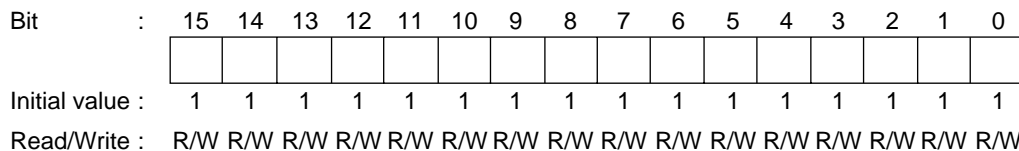

P1DDR—Port 1 Data Direction Register

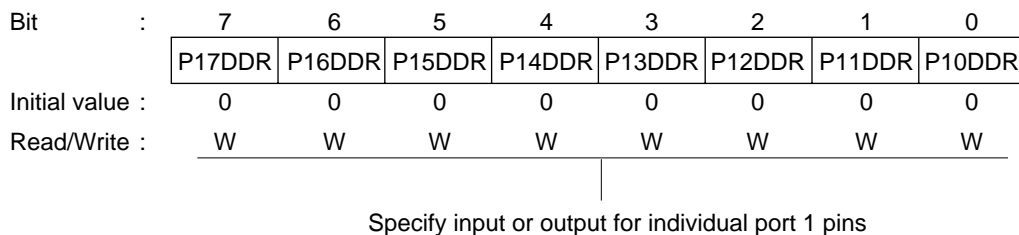

P2DDR—Port 2 Data Direction Register**H'FEB1****Port 2**

Bit	:	7	6	5	4	3	2	1	0
		P27DDR	P26DDR	P25DDR	P24DDR	P23DDR	P22DDR	P21DDR	P20DDR
Initial value :		0	0	0	0	0	0	0	0
Read/Write :		W	W	W	W	W	W	W	W

Specify input or output for individual port 2 pins

P3DDR—Port 3 Data Direction Register**H'FEB2****Port 3**

Bit	:	7	6	5	4	3	2	1	0
		—	—	P35DDR	P34DDR	P33DDR	P32DDR	P31DDR	P30DDR
Initial value :		Undefined	Undefined	0	0	0	0	0	0
Read/Write :		—	—	W	W	W	W	W	W

Specify input or output for individual port 3 pins

P5DDR—Port 5 Data Direction Register**H'FEB4****Port 5**

Bit	:	7	6	5	4	3	2	1	0
		—	—	—	—	P53DDR	P52DDR	P51DDR	P50DDR
Initial value :		Undefined	Undefined	Undefined	Undefined	0	0	0	0
Read/Write :		—	—	—	—	W	W	W	W

Specify input or output for individual port 5 pins

Bit	:	7	6	5	4	3	2	1	0
		P67DDR	P66DDR	P65DDR	P64DDR	P63DDR	P62DDR	P61DDR	P60DDR
Initial value	:	0	0	0	0	0	0	0	0
Read/Write	:	W	W	W	W	W	W	W	W

Specify input or output for individual port 6 pins

PADDR—Port A Data Direction Register

H'FEB9

Port A

Bit	:	7	6	5	4	3	2	1	0
		PA7DDR	PA6DDR	PA5DDR	PA4DDR	PA3DDR	PA2DDR	PA1DDR	PA0DDR
Initial value	:	0	0	0	0	0	0	0	0
Read/Write	:	W	W	W	W	W	W	W	W

Specify input or output for individual port A pins

PBDDR—Port B Data Direction Register

H'FEBA

Port B

Bit	:	7	6	5	4	3	2	1	0
		PB7DDR	PB6DDR	PB5DDR	PB4DDR	PB3DDR	PB2DDR	PB1DDR	PB0DDR
Initial value	:	0	0	0	0	0	0	0	0
Read/Write	:	W	W	W	W	W	W	W	W

Specify input or output for individual port B pins

PCDDR—Port C Data Direction Register**H'FE8B****Port C**

Bit	:	7	6	5	4	3	2	1	0
		PC7DDR	PC6DDR	PC5DDR	PC4DDR	PC3DDR	PC2DDR	PC1DDR	PC0DDR
Initial value	:	0	0	0	0	0	0	0	0
Read/Write	:	W	W	W	W	W	W	W	W

Specify input or output for individual port C pins

PDDDR—Port D Data Direction Register**H'FE9C****Port D**

Bit	:	7	6	5	4	3	2	1	0
		PD7DDR	PD6DDR	PD5DDR	PD4DDR	PD3DDR	PD2DDR	PD1DDR	PD0DDR
Initial value	:	0	0	0	0	0	0	0	0
Read/Write	:	W	W	W	W	W	W	W	W

Specify input or output for individual port D pins

PEDDR—Port E Data Direction Register**H'FEAD****Port E**

Bit	:	7	6	5	4	3	2	1	0
		PE7DDR	PE6DDR	PE5DDR	PE4DDR	PE3DDR	PE2DDR	PE1DDR	PE0DDR
Initial value	:	0	0	0	0	0	0	0	0
Read/Write	:	W	W	W	W	W	W	W	W

Specify input or output for individual port E pins

PFDDR—Port F Data Direction Register**H'FEBE****Port F**

Bit	:	7	6	5	4	3	2	1	0
		PF7DDR	PF6DDR	PF5DDR	PF4DDR	PF3DDR	PF2DDR	PF1DDR	PF0DDR

Modes 1, 2, 4 to 6

Initial value : 1 0 0 0 0 0 0 0

Read/Write : W W W W W W W W

Modes 3, 7

Initial value : 0 0 0 0 0 0 0 0

Read/Write : W W W W W W W W

Specify input or output for individual port F pins

PGDDR—Port G Data Direction Register**H'FEBF****Port G**

Bit	:	7	6	5	4	3	2	1	0
		—	—	—	PG4DDR	PG3DDR	PG2DDR	PG1DDR	PG0DDR

Modes 1, 4, 5

Initial value : Undefined Undefined Undefined 1 0 0 0 0

Read/Write : — — — W W W W W

Modes 2, 3, 6, 7

Initial value : Undefined Undefined Undefined 0 0 0 0 0

Read/Write : — — — W W W W W

Specify input or output for individual port G pins

IPRA	— Interrupt Priority Register A	H'FEC4	Interrupt Controller
IPRB	— Interrupt Priority Register B	H'FEC5	Interrupt Controller
IPRC	— Interrupt Priority Register C	H'FEC6	Interrupt Controller
IPRD	— Interrupt Priority Register D	H'FEC7	Interrupt Controller
IPRE	— Interrupt Priority Register E	H'FEC8	Interrupt Controller
IPRF	— Interrupt Priority Register F	H'FEC9	Interrupt Controller
IPRG	— Interrupt Priority Register G	H'FECA	Interrupt Controller
IPRH	— Interrupt Priority Register H	H'FECB	Interrupt Controller
IPRI	— Interrupt Priority Register I	H'FECC	Interrupt Controller
IPRJ	— Interrupt Priority Register J	H'FECD	Interrupt Controller
IPRK	— Interrupt Priority Register K	H'FECE	Interrupt Controller

Bit	:	7	6	5	4	3	2	1	0
		—	IPR6	IPR5	IPR4	—	IPR2	IPR1	IPR0
Initial value	:	0	1	1	1	0	1	1	1
Read/Write	:	—	R/W	R/W	R/W	—	R/W	R/W	R/W

Set priority (levels 7 to 0) for interrupt sources

Correspondence between Interrupt Sources and IPR Settings

Register	Bits	
	6 to 4	2 to 0
IPRA	IRQ0	IRQ1
IPRB	IRQ2	IRQ4
	IRQ3	IRQ5
IPRC	IRQ6	DTC
	IRQ7	
IPRD	WDT	—*
IPRE	—*	A/D converter
IPRF	TPU channel 0	TPU channel 1
IPRG	TPU channel 2	TPU channel 3
IPRH	TPU channel 4	TPU channel 5
IPRI	8-bit timer channel 0	8-bit timer channel 1
IPRJ	—*	SCI channel 0
IPRK	SCI channel 1	SCI channel 2

Note: * Reserved bits. These bits cannot be modified and are always read as 1.

ABWCR—Bus Width Control Register**H'FED0****Bus Controller**

Bit	:	7	6	5	4	3	2	1	0
		ABW7	ABW6	ABW5	ABW4	ABW3	ABW2	ABW1	ABW0

Modes 1 to 3, 5 to 7

Initial value :	1	1	1	1	1	1	1	1
R/W :	R/W	R/W	R/W	R/W	R/W	R/W	R/W	R/W

Mode 4

Initial value :	0	0	0	0	0	0	0	0
Read/Write :	R/W	R/W	R/W	R/W	R/W	R/W	R/W	R/W

Area 7 to 0 Bus Width Control

0	Area n is designated for 16-bit access
1	Area n is designated for 8-bit access

(n = 7 to 0)

ASTCR—Access State Control Register**H'FED1****Bus Controller**

Bit	:	7	6	5	4	3	2	1	0
		AST7	AST6	AST5	AST4	AST3	AST2	AST1	AST0

Initial value :	1	1	1	1	1	1	1	1
Read/Write :	R/W	R/W	R/W	R/W	R/W	R/W	R/W	R/W

Area 7 to 0 Access State Control

0	Area n is designated for 2-state access Wait state insertion in area n external space is disabled
1	Area n is designated for 3-state access Wait state insertion in area n external space is enabled

(n = 7 to 0)

Bit	:	7	6	5	4	3	2	1	0
		W71	W70	W61	W60	W51	W50	W41	W40
Initial value :		1	1	1	1	1	1	1	1
Read/Write :		R/W	R/W	R/W	R/W	R/W	R/W	R/W	R/W

Area 4 Wait Control

0	0	Program wait not inserted
	1	1 program wait state inserted
1	0	2 program wait states inserted
	1	3 program wait states inserted

Area 5 Wait Control

0	0	Program wait not inserted
	1	1 program wait state inserted
1	0	2 program wait states inserted
	1	3 program wait states inserted

Area 6 Wait Control

0	0	Program wait not inserted
	1	1 program wait state inserted
1	0	2 program wait states inserted
	1	3 program wait states inserted

Area 7 Wait Control

0	0	Program wait not inserted
	1	1 program wait state inserted
1	0	2 program wait states inserted
	1	3 program wait states inserted

Bit	:	7	6	5	4	3	2	1	0
		W31	W30	W21	W20	W11	W10	W01	W00
Initial value	:	1	1	1	1	1	1	1	1
Read/Write	:	R/W	R/W	R/W	R/W	R/W	R/W	R/W	R/W

Area 0 Wait Control

0	0	Program wait not inserted
	1	1 program wait state inserted
1	0	2 program wait states inserted
	1	3 program wait states inserted

Area 1 Wait Control

0	0	Program wait not inserted
	1	1 program wait state inserted
1	0	2 program wait states inserted
	1	3 program wait states inserted

Area 2 Wait Control

0	0	Program wait not inserted
	1	1 program wait state inserted
1	0	2 program wait states inserted
	1	3 program wait states inserted

Area 3 Wait Control

0	0	Program wait not inserted
	1	1 program wait state inserted
1	0	2 program wait states inserted
	1	3 program wait states inserted

Bit	7	6	5	4	3	2	1	0
	ICIS1	ICIS0	BRSTRM	BRSTS1	BRSTS0	—	—	—

Initial value : 1 1 0 1 0 0 0 0

Read/Write : R/W R/W R/W R/W R/W R/W R/W R/W

Reserved
Only 0 should be written
to these bits

Burst Cycle Select 0

0	Max. 4 words in burst access
1	Max. 8 words in burst access

Burst Cycle Select 1

0	Burst cycle comprises 1 state
1	Burst cycle comprises 2 states

Area 0 Burst ROM Enable

0	Area 0 is basic bus interface
1	Area 0 is burst ROM interface

Idle Cycle Insert 0

0	Idle cycle not inserted in case of successive external read and external write cycles
1	Idle cycle inserted in case of successive external read and external write cycles

Idle Cycle Insert 1

0	Idle cycle not inserted in case of successive external read cycles in different areas
1	Idle cycle inserted in case of successive external read cycles in different areas

Bit	7	6	5	4	3	2	1	0
	BRLE	—	EAE	—	—	—	—	WAITE

Initial value : 0 0 1 1 1 1 0 0

Read/Write : R/W R/W R/W R/W R/W R/W R/W R/W

Reserved
Only 0 should be written to this bit

WAIT Pin Enable

0	Wait input by $\overline{\text{WAIT}}$ pin disabled
1	Wait input by $\overline{\text{WAIT}}$ pin enabled

Reserved
Only 1 should be written to these bits

External Addresses H'010000 to H'01FFFF Enable

0	On-chip ROM (H8S/2355) or reserved area* (H8S/2353)
1	External addresses (in external expansion mode) or reserved area (in single-chip mode)

Notes: * Do not access a reserved area.

Reserved
Only 0 should be written to this bit

Bus Release Enable

0	External bus release is disabled
1	External bus release is enabled

ISCRH

Bit	:	15	14	13	12	11	10	9	8
		IRQ7SCB	IRQ7SCA	IRQ6SCB	IRQ6SCA	IRQ5SCB	IRQ5SCA	IRQ4SCB	IRQ4SCA
Initial value	:	0	0	0	0	0	0	0	0
Read/Write	:	R/W	R/W	R/W	R/W	R/W	R/W	R/W	R/W

|
 IRQ7 to IRQ4 Sense Control

ISCRL

Bit	:	7	6	5	4	3	2	1	0
		IRQ3SCB	IRQ3SCA	IRQ2SCB	IRQ2SCA	IRQ1SCB	IRQ1SCA	IRQ0SCB	IRQ0SCA
Initial value	:	0	0	0	0	0	0	0	0
Read/Write	:	R/W	R/W	R/W	R/W	R/W	R/W	R/W	R/W

|
 IRQ3 to IRQ0 Sense Control

IRQnSCB	IRQnSCA	Interrupt Request Generation
0	0	$\overline{\text{IRQn}}$ input low level
	1	Falling edge of $\overline{\text{IRQn}}$ input
1	0	Rising edge of $\overline{\text{IRQn}}$ input
	1	Both falling and rising edges of $\overline{\text{IRQn}}$ input

(n = 7 to 0)

IER—IRQ Enable Register**H'FF2E****Interrupt Controller**

Bit	:	7	6	5	4	3	2	1	0
		IRQ7E	IRQ6E	IRQ5E	IRQ4E	IRQ3E	IRQ2E	IRQ1E	IRQ0E
Initial value :		0	0	0	0	0	0	0	0
Read/Write :		R/W	R/W	R/W	R/W	R/W	R/W	R/W	R/W

|
IRQn Enable

0	IRQn interrupt disabled
1	IRQn interrupt enabled

(n = 7 to 0)

ISR—IRQ Status Register**H'FF2F****Interrupt Controller**

Bit	:	7	6	5	4	3	2	1	0
		IRQ7F	IRQ6F	IRQ5F	IRQ4F	IRQ3F	IRQ2F	IRQ1F	IRQ0F
Initial value :		0	0	0	0	0	0	0	0
Read/Write :		R/(W)*	R/(W)*	R/(W)*	R/(W)*	R/(W)*	R/(W)*	R/(W)*	R/(W)*

|
Indicate the status of IRQ7 to IRQ0 interrupt requests

Note: * Can only be written with 0 for flag clearing.

Bit	:	7	6	5	4	3	2	1	0
		DTCE7	DTCE6	DTCE5	DTCE4	DTCE3	DTCE2	DTCE1	DTCE0
Initial value :		0	0	0	0	0	0	0	0
Read/Write :		R/W	R/W	R/W	R/W	R/W	R/W	R/W	R/W

DTC Activation Enable

0	DTC activation by this interrupt is disabled [Clearing conditions] • When the DISEL bit is 1 and data transfer has ended • When the specified number of transfers have ended
1	DTC activation by this interrupt is enabled [Holding condition] When the DISEL bit is 0 and the specified number of transfers have not ended

Correspondence between Interrupt Sources and DTCER

Bits

Register	7	6	5	4	3	2	1	0
DTCERA	IRQ0	IRQ1	IRQ2	IRQ3	IRQ4	IRQ5	IRQ6	IRQ7
DTCERB	—	ADI	TGI0A	TGI0B	TGI0C	TGI0D	TGI1A	TGI1B
DTCERC	TGI2A	TGI2B	TGI3A	TGI3B	TGI3C	TGI3D	TGI4A	TGI4B
DTCERD	—	—	TGI5A	TGI5B	CMIA0	CMIB0	CMIA1	CMIB1
DTCERE	—	—	—	—	RX10	TX10	RX11	TX11
DTCERF	RX12	TX12	—	—	—	—	—	—

Bit	:	7	6	5	4	3	2	1	0
		SWDTE	DTVEC6	DTVEC5	DTVEC4	DTVEC3	DTVEC2	DTVEC1	DTVEC0
Initial value :		0	0	0	0	0	0	0	0
Read/Write :		R/(W)*	R/W	R/W	R/W	R/W	R/W	R/W	R/W

Sets vector number for DTC software activation

DTC Software Activation Enable

0	DTC software activation is disabled [Clearing condition] When the DISEL bit is 0 and the specified number of transfers have not ended
1	DTC software activation is enabled [Holding conditions] <ul style="list-style-type: none"> • When the DISEL bit is 1 and data transfer has ended • When the specified number of transfers have ended • During data transfer due to software activation

Note: * A value of 1 can always be written to the SWDTE bit, but 0 can only be written after 1 is read.

Bit	7	6	5	4	3	2	1	0
	SSBY	STS2	STS1	STS0	OPE	—	—	—
Initial value :	0	0	0	0	1	0	0	0
Read/Write :	R/W	R/W	R/W	R/W	R/W	—	—	R/W

Reserved
Only 0 should be written to this bit

Output Port Enable

0	In software standby mode, address bus and bus control signals are high-impedance
1	In software standby mode, address bus and bus control signals retain output state

Standby Timer Select

0	0	0	Standby time = 8192 states
		1	Standby time = 16384 states
	1	0	Standby time = 32768 states
		1	Standby time = 65536 states
1	0	0	Standby time = 131072 states
		1	Standby time = 262144 states
	1	0	Reserved
		1	Standby time = 16 states

Software Standby

0	Transition to sleep mode after execution of SLEEP instruction
1	Transition to software standby mode after execution of SLEEP instruction

Bit	:	7	6	5	4	3	2	1	0
		—	—	INTM1	INTM0	NMIEG	—	—	RAME
Initial value	:	0	0	0	0	0	0	0	1
Read/Write	:	R/W	—	R/W	R/W	R/W	—	R/W	R/W

Reserved
Only 0 should be written to this bit

RAM Enable

0	On-chip RAM disabled
1	On-chip RAM enabled

NMI Input Edge Select

0	Falling edge
1	Rising edge

Interrupt Control Mode Selection

0	0	Interrupt control mode 0
	1	—
1	0	Interrupt control mode 2
	1	—

Reserved
Only 0 should be written to this bit

Bit	:	7	6	5	4	3	2	1	0
		PSTOP	—	—	—	—	SCK2	SCK1	SCK0
Initial value	:	0	0	0	0	0	0	0	0
Read/Write	:	R/W	R/W	—	—	—	R/W	R/W	R/W

Bus Master Clock Select

0	0	0	Bus master is in high-speed mode
		1	Medium-speed clock is $\varnothing/2$
	1	0	Medium-speed clock is $\varnothing/4$
		1	Medium-speed clock is $\varnothing/8$
1	0	0	Medium-speed clock is $\varnothing/16$
		1	Medium-speed clock is $\varnothing/32$
	1	—	—

\varnothing Clock Output Control

PSTOP	Normal Operation	Sleep Mode	Software Standby Mode	Hardware Standby Mode
0	\varnothing output	\varnothing output	Fixed high	High impedance
1	Fixed high	Fixed high	Fixed high	High impedance

Bit	:	7	6	5	4	3	2	1	0
		—	—	—	—	—	MDS2	MDS1	MDS0
Initial value	:	1	0	0	0	0	—*	—*	—*
Read/Write	:	—	—	—	—	—	R	R	R

Current mode pin operating mode

Note: * Determined by pins MD₂ to MD₀

MSTPCRH — Module Stop Control Register H H'FF3C

Power-Down State

MSTPCRL — Module Stop Control Register L H'FF3D

Power-Down State

		MSTPCRH							MSTPCRL								
Bit	:	15	14	13	12	11	10	9	8	7	6	5	4	3	2	1	0
Initial value	:	0	0	1	1	1	1	1	1	1	1	1	1	1	1	1	1
Read/Write	:	R/W	R/W	R/W	R/W	R/W	R/W	R/W	R/W	R/W	R/W	R/W	R/W	R/W	R/W	R/W	R/W

Specifies module stop mode

0	Module stop mode cleared
1	Module stop mode set

Reserved Register

H'FF

Bit	:	7	6	5	4	3	2	1	0
		—	—	—	—	—	—	—	—
Initial value	:	0	0	0	0	0	0	0	0
Read/Write	:	—	—	R/W	—	—	—	—	—

Reserved
Only 0 should be written to these bits

PORT1—Port 1 Register**H'FF50****Port 1**

Bit	:	7	6	5	4	3	2	1	0
		P17	P16	P15	P14	P13	P12	P11	P10
Initial value	:	—*	—*	—*	—*	—*	—*	—*	—*
Read/Write	:	R	R	R	R	R	R	R	R

|
State of port 1 pins

Note: * Determined by the state of pins P17 to P10.

PORT2—Port 2 Register**H'FF51****Port 2**

Bit	:	7	6	5	4	3	2	1	0
		P27	P26	P25	P24	P23	P22	P21	P20
Initial value	:	—*	—*	—*	—*	—*	—*	—*	—*
Read/Write	:	R	R	R	R	R	R	R	R

|
State of port 2 pins

Note: * Determined by the state of pins P27 to P20.

PORT3—Port 3 Register**H'FF52****Port 3**

Bit	:	7	6	5	4	3	2	1	0
		—	—	P35	P34	P33	P32	P31	P30
Initial value	:	Undefined	Undefined	—*	—*	—*	—*	—*	—*
Read/Write	:	—	—	R	R	R	R	R	R

|
State of port 3 pins

Note: * Determined by the state of pins P35 to P30.

PORT4—Port 4 Register**H'FF53****Port 4**

Bit	:	7	6	5	4	3	2	1	0
		P47	P46	P45	P44	P43	P42	P41	P40
Initial value	:	—*	—*	—*	—*	—*	—*	—*	—*
Read/Write	:	R	R	R	R	R	R	R	R

|
State of port 4 pins

Note: * Determined by the state of pins P4₇ to P4₀.

PORT5—Port 5 Register**H'FF54****Port 5**

Bit	:	7	6	5	4	3	2	1	0
		—	—	—	—	P53	P52	P51	P50
Initial value	:	Undefined	Undefined	Undefined	Undefined	—*	—*	—*	—*
Read/Write	:	—	—	—	—	R	R	R	R

|
State of port 5 pins

Note: * Determined by the state of pins P5₃ to P5₀.

PORT6—Port 6 Register**H'FF55****Port 6**

Bit	:	7	6	5	4	3	2	1	0
		P67	P66	P65	P64	P63	P62	P61	P60
Initial value	:	—*	—*	—*	—*	—*	—*	—*	—*
Read/Write	:	R	R	R	R	R	R	R	R

|
State of port 6 pins

Note: * Determined by the state of pins P6₇ to P6₀.

PORTA—Port A Register**H'FF59****Port A**

Bit	:	7	6	5	4	3	2	1	0
		PA7	PA6	PA5	PA4	PA3	PA2	PA1	PA0
Initial value	:	—*	—*	—*	—*	—*	—*	—*	—*
Read/Write	:	R	R	R	R	R	R	R	R

|
State of port A pins

Note: * Determined by the state of pins PA₇ to PA₀.

PORTB—Port B Register**H'FF5A****Port B**

Bit	:	7	6	5	4	3	2	1	0
		PB7	PB6	PB5	PB4	PB3	PB2	PB1	PB0
Initial value	:	—*	—*	—*	—*	—*	—*	—*	—*
Read/Write	:	R	R	R	R	R	R	R	R

|
State of port B pins

Note: * Determined by the state of pins PB₇ to PB₀.

PORTC—Port C Register**H'FF5B****Port C**

Bit	:	7	6	5	4	3	2	1	0
		PC7	PC6	PC5	PC4	PC3	PC2	PC1	PC0
Initial value	:	—*	—*	—*	—*	—*	—*	—*	—*
Read/Write	:	R	R	R	R	R	R	R	R

|
State of port C pins

Note: * Determined by the state of pins PC₇ to PC₀.

PORTD—Port D Register**H'FF5C****Port D**

Bit	:	7	6	5	4	3	2	1	0
		PD7	PD6	PD5	PD4	PD3	PD2	PD1	PD0
Initial value	:	—*	—*	—*	—*	—*	—*	—*	—*
Read/Write	:	R	R	R	R	R	R	R	R

|
State of port D pins

Note: * Determined by the state of pins PD₇ to PD₀.

PORTE—Port E Register**H'FF5D****Port E**

Bit	:	7	6	5	4	3	2	1	0
		PE7	PE6	PE5	PE4	PE3	PE2	PE1	PE0
Initial value	:	—*	—*	—*	—*	—*	—*	—*	—*
Read/Write	:	R	R	R	R	R	R	R	R

|
State of port E pins

Note: * Determined by the state of pins PE₇ to PE₀.

PORTF—Port F Register**H'FF5E****Port F**

Bit	:	7	6	5	4	3	2	1	0
		PF7	PF6	PF5	PF4	PF3	PF2	PF1	PF0
Initial value	:	—*	—*	—*	—*	—*	—*	—*	—*
Read/Write	:	R	R	R	R	R	R	R	R

|
State of port F pins

Note: * Determined by the state of pins PF₇ to PF₀.

PORTG—Port G Register**H'FF5F****Port G**

Bit	:	7	6	5	4	3	2	1	0
		—	—	—	PG4	PG3	PG2	PG1	PG0
Initial value	:	Undefined	Undefined	Undefined	—*	—*	—*	—*	—*
Read/Write	:	—	—	—	R	R	R	R	R

|
State of port G pins

Note: * Determined by the state of pins PG₄ to PG₀.

P1DR—Port 1 Data Register**H'FF60****Port 1**

Bit	:	7	6	5	4	3	2	1	0
		P17DR	P16DR	P15DR	P14DR	P13DR	P12DR	P11DR	P10DR
Initial value	:	0	0	0	0	0	0	0	0
Read/Write	:	R/W	R/W	R/W	R/W	R/W	R/W	R/W	R/W

|
Stores output data for port 1 pins (P1₇ to P1₀)

P2DR—Port 2 Data Register**H'FF61****Port 2**

Bit	:	7	6	5	4	3	2	1	0
		P27DR	P26DR	P25DR	P24DR	P23DR	P22DR	P21DR	P20DR
Initial value	:	0	0	0	0	0	0	0	0
Read/Write	:	R/W	R/W	R/W	R/W	R/W	R/W	R/W	R/W

|
Stores output data for port 2 pins (P2₇ to P2₀)

P3DR—Port 3 Data Register**H'FF62****Port 3**

Bit	:	7	6	5	4	3	2	1	0
		—	—	P35DR	P34DR	P33DR	P32DR	P31DR	P30DR
Initial value	:	Undefined	Undefined	0	0	0	0	0	0
Read/Write	:	—	—	R/W	R/W	R/W	R/W	R/W	R/W

Stores output data for port 3 pins (P3₅ to P3₀)

P5DR—Port 5 Data Register**H'FF64****Port 5**

Bit	:	7	6	5	4	3	2	1	0
		—	—	—	—	P53DR	P52DR	P51DR	P50DR
Initial value	:	Undefined	Undefined	Undefined	Undefined	0	0	0	0
Read/Write	:	—	—	—	—	R/W	R/W	R/W	R/W

Stores output data for port 5 pins (P5₃ to P5₀)

P6DR—Port 6 Data Register**H'FF65****Port 6**

Bit	:	7	6	5	4	3	2	1	0
		P67DR	P66DR	P65DR	P64DR	P63DR	P62DR	P61DR	P60DR
Initial value	:	0	0	0	0	0	0	0	0
Read/Write	:	R/W	R/W	R/W	R/W	R/W	R/W	R/W	R/W

Stores output data for port 6 pins (P6₇ to P6₀)

PADR—Port A Data Register**H'FF69****Port A**

Bit	:	7	6	5	4	3	2	1	0
		PA7DR	PA6DR	PA5DR	PA4DR	PA3DR	PA2DR	PA1DR	PA0DR
Initial value	:	0	0	0	0	0	0	0	0
Read/Write	:	R/W	R/W	R/W	R/W	R/W	R/W	R/W	R/W

Stores output data for port A pins (PA₇ to PA₀)

PBDR—Port B Data Register**H'FF6A****Port B**

Bit	:	7	6	5	4	3	2	1	0
		PB7DR	PB6DR	PB5DR	PB4DR	PB3DR	PB2DR	PB1DR	PB0DR
Initial value	:	0	0	0	0	0	0	0	0
Read/Write	:	R/W	R/W	R/W	R/W	R/W	R/W	R/W	R/W

Stores output data for port B pins (PB₇ to PB₀)

PCDR—Port C Data Register**H'FF6B****Port C**

Bit	:	7	6	5	4	3	2	1	0
		PC7DR	PC6DR	PC5DR	PC4DR	PC3DR	PC2DR	PC1DR	PC0DR
Initial value	:	0	0	0	0	0	0	0	0
Read/Write	:	R/W	R/W	R/W	R/W	R/W	R/W	R/W	R/W

Stores output data for port C pins (PC₇ to PC₀)

PDDR—Port D Data Register**H'FF6C****Port D**

Bit	:	7	6	5	4	3	2	1	0
		PD7DR	PD6DR	PD5DR	PD4DR	PD3DR	PD2DR	PD1DR	PD0DR
Initial value	:	0	0	0	0	0	0	0	0
Read/Write	:	R/W	R/W	R/W	R/W	R/W	R/W	R/W	R/W

Stores output data for port D pins (PD₇ to PD₀)

PEDR—Port E Data Register**H'FF6D****Port E**

Bit	:	7	6	5	4	3	2	1	0
		PE7DR	PE6DR	PE5DR	PE4DR	PE3DR	PE2DR	PE1DR	PE0DR
Initial value	:	0	0	0	0	0	0	0	0
Read/Write	:	R/W	R/W	R/W	R/W	R/W	R/W	R/W	R/W

Stores output data for port E pins (PE₇ to PE₀)

PFDR—Port F Data Register**H'FF6E****Port F**

Bit	:	7	6	5	4	3	2	1	0
		PF7DR	PF6DR	PF5DR	PF4DR	PF3DR	PF2DR	PF1DR	PF0DR
Initial value	:	0	0	0	0	0	0	0	0
Read/Write	:	R/W	R/W	R/W	R/W	R/W	R/W	R/W	R/W

Stores output data for port F pins (PF₇ to PF₀)

PGDR—Port G Data Register**H'FF6F****Port G**

Bit	:	7	6	5	4	3	2	1	0
		—	—	—	PG4DR	PG3DR	PG2DR	PG1DR	PG0DR
Initial value	:	Undefined	Undefined	Undefined	0	0	0	0	0
Read/Write	:	—	—	—	R/W	R/W	R/W	R/W	R/W

Stores output data for port G pins (PG₄ to PG₀)

PAPCR—Port A MOS Pull-Up Control Register**H'FF70****Port A**

Bit	:	7	6	5	4	3	2	1	0
		PA7PCR	PA6PCR	PA5PCR	PA4PCR	PA3PCR	PA2PCR	PA1PCR	PA0PCR
Initial value	:	0	0	0	0	0	0	0	0
Read/Write	:	R/W	R/W	R/W	R/W	R/W	R/W	R/W	R/W

Controls the MOS input pull-up function incorporated into port A on a bit-by-bit basis

PBPCR—Port B MOS Pull-Up Control Register**H'FF71****Port B**

Bit	:	7	6	5	4	3	2	1	0
		PB7PCR	PB6PCR	PB5PCR	PB4PCR	PB3PCR	PB2PCR	PB1PCR	PB0PCR
Initial value	:	0	0	0	0	0	0	0	0
Read/Write	:	R/W	R/W	R/W	R/W	R/W	R/W	R/W	R/W

Controls the MOS input pull-up function incorporated into port B on a bit-by-bit basis

PCPCR—Port C MOS Pull-Up Control Register H'FF72**Port C**

Bit	:	7	6	5	4	3	2	1	0
		PC7PCR	PC6PCR	PC5PCR	PC4PCR	PC3PCR	PC2PCR	PC1PCR	PC0PCR
Initial value	:	0	0	0	0	0	0	0	0
Read/Write	:	R/W	R/W	R/W	R/W	R/W	R/W	R/W	R/W

Controls the MOS input pull-up function incorporated into port C on a bit-by-bit basis

PDPCR—Port D MOS Pull-Up Control Register H'FF73**Port D**

Bit	:	7	6	5	4	3	2	1	0
		PD7PCR	PD6PCR	PD5PCR	PD4PCR	PD3PCR	PD2PCR	PD1PCR	PD0PCR
Initial value	:	0	0	0	0	0	0	0	0
Read/Write	:	R/W	R/W	R/W	R/W	R/W	R/W	R/W	R/W

Controls the MOS input pull-up function incorporated into port D on a bit-by-bit basis

PEPCR—Port E MOS Pull-Up Control Register H'FF74**Port E**

Bit	:	7	6	5	4	3	2	1	0
		PE7PCR	PE6PCR	PE5PCR	PE4PCR	PE3PCR	PE2PCR	PE1PCR	PE0PCR
Initial value	:	0	0	0	0	0	0	0	0
Read/Write	:	R/W	R/W	R/W	R/W	R/W	R/W	R/W	R/W

Controls the MOS input pull-up function incorporated into port E on a bit-by-bit basis

Bit	:	7	6	5	4	3	2	1	0
		—	—	P35ODR	P34ODR	P33ODR	P32ODR	P31ODR	P30ODR
Initial value	:	Undefined	Undefined	0	0	0	0	0	0
Read/Write	:	—	—	R/W	R/W	R/W	R/W	R/W	R/W

Controls the PMOS on/off status for each port 3 pin (P3₅ to P3₀)

Bit	:	7	6	5	4	3	2	1	0
		PA7ODR	PA6ODR	PA5ODR	PA4ODR	PA3ODR	PA2ODR	PA1ODR	PA0ODR
Initial value	:	0	0	0	0	0	0	0	0
Read/Write	:	R/W	R/W	R/W	R/W	R/W	R/W	R/W	R/W

Controls the PMOS on/off status for each port A pin (PA₇ to PA₀)

Bit	:	7	6	5	4	3	2	1	0
		C/ \bar{A}	CHR	PE	O/ \bar{E}	STOP	MP	CKS1	CKS0
Initial value :		0	0	0	0	0	0	0	0
Read/Write :		R/W	R/W	R/W	R/W	R/W	R/W	R/W	R/W

Clock Select

0	0	\emptyset clock
	1	$\emptyset/4$ clock
1	0	$\emptyset/16$ clock
	1	$\emptyset/64$ clock

Multiprocessor Mode

0	Multiprocessor function disabled
1	Multiprocessor format selected

Stop Bit Length

0	1 stop bit
1	2 stop bits

Parity Mode

0	Even parity
1	Odd parity

Parity Enable

0	Parity bit addition and checking disabled
1	Parity bit addition and checking enabled

Character Length

0	8-bit data
1	7-bit data*

Note: * When 7-bit data is selected, the MSB (bit 7) of TDR is not transmitted.

Asynchronous Mode/Synchronous Mode Select

0	Asynchronous mode
1	Synchronous mode

Bit	:	7	6	5	4	3	2	1	0
		GM	CHR	PE	O/E	STOP	MP	CKS1	CKS0

Initial value : 0 0 0 0 0 0 0 0 0

Read/Write : R/W R/W R/W R/W R/W R/W R/W R/W

Clock Select

0	0	∅ clock
	1	∅/4 clock
1	0	∅/16 clock
	1	∅/64 clock

Multiprocessor Mode

0	Multiprocessor function disabled
1	Setting prohibited

Stop Bit Length

0	Setting prohibited
1	2 stop bits

Parity Mode

0	Even parity
1	Odd parity

Parity Enable

0	Setting prohibited
1	Parity bit addition and checking enabled

Character Length

0	8-bit data
1	Setting prohibited

GSM Mode _____

0	Normal smart card interface mode operation <ul style="list-style-type: none"> • TEND flag generated 12.5 etu after beginning of start bit • Clock output on/off control only
1	GSM mode smart card interface mode operation <ul style="list-style-type: none"> • TEND flag generated 11.0 etu after beginning of start bit • Fixed high/low-level control possible (set in SCR) in addition to clock output on/off control

Note: etu (Elementary Time Unit): Interval for transfer of one bit

Bit	:	7	6	5	4	3	2	1	0
Initial value	:	1	1	1	1	1	1	1	1
Read/Write	:	R/W	R/W	R/W	R/W	R/W	R/W	R/W	R/W

Sets the serial transfer bit rate

Note: See section 12.2.8, Bit Rate Register (BRR), for details.

Bit	:	7	6	5	4	3	2	1	0
		TIE	RIE	TE	RE	MPIE	TEIE	CKE1	CKE0
Initial value	:	0	0	0	0	0	0	0	0
Read/Write	:	R/W	R/W	R/W	R/W	R/W	R/W	R/W	R/W

Clock Enable

0	0	Asynchronous mode	Internal clock/SCK pin functions as I/O port
		Synchronous mode	Internal clock/SCK pin functions as serial clock output
1		Asynchronous mode	Internal clock/SCK pin functions as clock output*1
		Synchronous mode	Internal clock/SCK pin functions as serial clock output
1	0	Asynchronous mode	External clock/SCK pin functions as clock input*2
		Synchronous mode	External clock/SCK pin functions as serial clock input
	1	Asynchronous mode	External clock/SCK pin functions as clock input*2
		Synchronous mode	External clock/SCK pin functions as serial clock input

Notes: 1. Outputs a clock of the same frequency as the bit rate.
 2. Inputs a clock with a frequency 16 times the bit rate.

Transmit End Interrupt Enable

0	Transmit end interrupt (TEI) request disabled
1	Transmit end interrupt (TEI) request enabled

Multiprocessor Interrupt Enable

0	Multiprocessor interrupts disabled [Clearing conditions] • When the MPIE bit is cleared to 0 • When MPB= 1 data is received
1	Multiprocessor interrupts enabled Receive interrupt (RXI) requests, receive error interrupt (ERI) requests, and setting of the RDRF, FER, and ORER flags in SSR are disabled until data with the multiprocessor bit set to 1 is received

Receive Enable

0	Reception disabled
1	Reception enabled

Transmit Enable

0	Transmission disabled
1	Transmission enabled

Receive Interrupt Enable

0	Receive data full interrupt (RXI) request and receive error interrupt (ERI) request disabled
1	Receive data full interrupt (RXI) request and receive error interrupt (ERI) request enabled

Transmit Interrupt Enable

0	Transmit data empty interrupt (TXI) requests disabled
1	Transmit data empty interrupt (TXI) requests enabled

Bit	:	7	6	5	4	3	2	1	0
		TIE	RIE	TE	RE	MPIE	TEIE	CKE1	CKE0
Initial value :		0	0	0	0	0	0	0	0
Read/Write :		R/W	R/W	R/W	R/W	R/W	R/W	R/W	R/W

Clock Enable

SMCR	SMR	SCR setting		SCK pin function
SMIF	C/Ā,GM	CKE1	CKE0	
0	See SCI specification			
1	0	0	0	Operates as port input pin
1	0	0	1	Clock output as SCK output pin
1	1	0	0	Fixed-low output as SCK output pin
1	1	0	1	Clock output as SCK output pin
1	1	1	0	Fixed-high output as SCK output pin
1	1	1	1	Clock output as SCK output pin

Transmit End Interrupt Enable

0	Transmit end interrupt (TEI) request disabled
1	Transmit end interrupt (TEI) request enabled

Multiprocessor Interrupt Enable

0	Multiprocessor interrupts disabled [Clearing conditions] • When the MPIE bit is cleared to 0 • When MPB= 1 data is received
1	Multiprocessor interrupts enabled Receive interrupt (RXI) requests, receive error interrupt (ERI) requests, and setting of the RDRF, FER, and ORER flags in SSR are disabled until data with the multiprocessor bit set to 1 is received

Receive Enable

0	Reception disabled
1	Reception enabled

Transmit Enable

0	Transmission disabled
1	Transmission enabled

Receive Interrupt Enable

0	Receive data full interrupt (RXI) request and receive error interrupt (ERI) request disabled
1	Receive data full interrupt (RXI) request and receive error interrupt (ERI) request enabled

Transmit Interrupt Enable

0	Transmit data empty interrupt (TXI) requests disabled
1	Transmit data empty interrupt (TXI) requests enabled

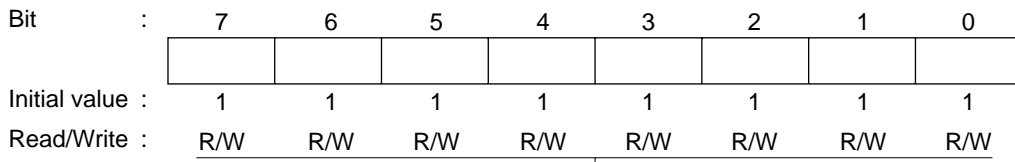

Stores data for serial transmission

Bit	:	7	6	5	4	3	2	1	0
		TDRE	RDRF	ORER	FER	PER	TEND	MPB	MPBT
Initial value	:	1	0	0	0	0	1	0	0
Read/Write	:	R/(W)*	R/(W)*	R/(W)*	R/(W)*	R/(W)*	R	R	R/W

Multiprocessor Bit Transfer

0	Data with a 0 multiprocessor bit is transmitted
1	Data with a 1 multiprocessor bit is transmitted

Multiprocessor Bit

0	[Clearing condition] When data with a 0 multiprocessor bit is received
1	[Setting condition] When data with a 1 multiprocessor bit is received

Transmit End

0	[Clearing condition] • When 0 is written to TDRE after reading TDRE = 1 • When the DTC is activated by a TXI interrupt and writes data to TDR
1	[Setting conditions] • When the TE bit in SCR is 0 • When TDRE = 1 at transmission of the last bit of a 1-byte serial transmit character

Parity Error

0	[Clearing condition] When 0 is written to PER after reading PER = 1
1	[Setting condition] When, in reception, the number of 1 bits in the receive data plus the parity bit does not match the parity setting (even or odd) specified by the O/E bit in SMR

Framing Error

0	[Clearing condition] When 0 is written to FER after reading FER = 1
1	[Setting condition] When the SCI checks whether the stop bit at the end of the receive data when reception ends, and the stop bit is 0

Overrun Error

0	[Clearing condition] When 0 is written to ORER after reading ORER = 1
1	[Setting condition] When the next serial reception is completed while RDRF = 1

Receive Data Register Full

0	[Clearing condition] • When 0 is written to RDRF after reading RDRF = 1 • When the DTC is activated by an RXI interrupt and reads data from RDR
1	[Setting condition] When serial reception ends normally and receive data is transferred from RSR to RDR

Transmit Data Register Empty

0	[Clearing condition] • When 0 is written to TDRE after reading TDRE = 1 • When the DTC is activated by a TXI interrupt and writes data to TDR
1	[Setting condition] • When the TE bit in SCR is 0 • When data is transferred from TDR to TSR and data can be written to TDR

Note: * Can only be written with 0 for flag clearing.

Bit	:	7	6	5	4	3	2	1	0
		TDRE	RDRF	ORER	ERS	PER	TEND	MPB	MPBT
Initial value	:	1	0	0	0	0	1	0	0
Read/Write	:	R/(W)*	R/(W)*	R/(W)*	R/(W)*	R/(W)*	R	R	R/W

Multiprocessor Bit Transfer

0	Data with a 0 multiprocessor bit is transmitted
1	Data with a 1 multiprocessor bit is transmitted

Multiprocessor Bit

0	[Clearing condition] When data with a 0 multiprocessor bit is received
1	[Setting condition] When data with a 1 multiprocessor bit is received

Transmit End

0	[Clearing condition] • When 0 is written to TDRE after reading TDRE = 1 • When the DTC is activated by a TXI interrupt and writes data to TDR
1	[Setting conditions] • On reset, or in standby mode or module stop mode • When the TE bit in SCR is 0 and the ERS bit is 0 • When TDRE = 1 and ERS = 0 (normal transmission) 2.5 etu after a 1-byte serial character is sent when GM = 0 • When TDRE = 1 and ERS = 0 (normal transmission) 1.0 etu after a 1-byte serial character is sent when GM = 1

Note: etu: Elementary Time Unit (the time taken to transmit one bit)

Parity Error

0	[Clearing condition] When 0 is written to PER after reading PER = 1
1	[Setting condition] When, in reception, the number of 1 bits in the receive data plus the parity bit does not match the parity setting (even or odd) specified by the O/E bit in SMR

Error Signal Status

0	[Clearing condition] • On reset, or in standby mode or module stop mode • When 0 is written to ERS after reading ERS = 1
1	[Setting condition] When the error signal is sampled at the low level

Note: Clearing the TE bit in SCR to 0 does not affect the ERS flag, which retains its prior state.

Overrun Error

0	[Clearing condition] When 0 is written to ORER after reading ORER = 1
1	[Setting condition] When the next serial reception is completed while RDRF = 1

Receive Data Register Full

0	[Clearing condition] • When 0 is written to RDRF after reading RDRF = 1 • When the DTC is activated by an RXI interrupt and reads data from RDR
1	[Setting condition] When serial reception ends normally and receive data is transferred from RSR to RDR

Transmit Data Register Empty

0	[Clearing condition] • When 0 is written to TDRE after reading TDRE = 1 • When the DTC is activated by a TXI interrupt and writes data to TDR
1	[Setting condition] • When the TE bit in SCR is 0 • When data is transferred from TDR to TSR and data can be written to TDR

Note: * Can only be written with 0 for flag clearing.

RDR0—Receive Data Register 0**H'FF7D SCIO, Smart Card Interface 0**

Bit	:	7	6	5	4	3	2	1	0
Initial value :		0	0	0	0	0	0	0	0
Read/Write :		R	R	R	R	R	R	R	R

Stores received serial data

SCMR0—Smart Card Mode Register 0**H'FF7E SCIO, Smart Card Interface 0**

Bit	:	7	6	5	4	3	2	1	0
		—	—	—	—	SDIR	SINV	—	SMIF
Initial value :		1	1	1	1	0	0	1	0
Read/Write :		—	—	—	—	R/W	R/W	—	R/W

Smart Card Interface Mode Select

0	Smart Card interface function is disabled
1	Smart Card interface function is enabled

Smart Card Data Invert

0	TDR contents are transmitted as they are Receive data is stored in RDR as it is
1	TDR contents are inverted before being transmitted Receive data is stored in RDR in inverted form

Smart Card Data Direction

0	TDR contents are transmitted LSB-first Receive data is stored in RDR LSB-first
1	TDR contents are transmitted MSB-first Receive data is stored in RDR MSB-first

Bit	:	7	6	5	4	3	2	1	0
		C/ \bar{A}	CHR	PE	O/ \bar{E}	STOP	MP	CKS1	CKS0

Initial value : 0 0 0 0 0 0 0 0 0

Read/Write : R/W R/W R/W R/W R/W R/W R/W R/W

Clock Select

0	0	\emptyset clock
	1	$\emptyset/4$ clock
1	0	$\emptyset/16$ clock
	1	$\emptyset/64$ clock

Multiprocessor Mode

0	Multiprocessor function disabled
1	Multiprocessor format selected

Stop Bit Length

0	1 stop bit
1	2 stop bits

Parity Mode

0	Even parity
1	Odd parity

Parity Enable

0	Parity bit addition and checking disabled
1	Parity bit addition and checking enabled

Character Length

0	8-bit data
1	7-bit data*

Note: * When 7-bit data is selected, the MSB (bit 7) of TDR is not transmitted.

Asynchronous Mode/Synchronous Mode Select

0	Asynchronous mode
1	Synchronous mode

Bit	:	7	6	5	4	3	2	1	0
		GM	CHR	PE	O/ \bar{E}	STOP	MP	CKS1	CKS0
Initial value	:	0	0	0	0	0	0	0	0
Read/Write	:	R/W	R/W	R/W	R/W	R/W	R/W	R/W	R/W

Clock Select

0	0	\emptyset clock
	1	$\emptyset/4$ clock
1	0	$\emptyset/16$ clock
	1	$\emptyset/64$ clock

Multiprocessor Mode

0	Multiprocessor function disabled
1	Setting prohibited

Stop Bit Length

0	Setting prohibited
1	2 stop bits

Parity Mode

0	Even parity
1	Odd parity

Parity Enable

0	Setting prohibited
1	Parity bit addition and checking enabled

Character Length

0	8-bit data
1	Setting prohibited

GSM Mode

0	Normal smart card interface mode operation <ul style="list-style-type: none"> • TEND flag generated 12.5 etu after beginning of start bit • Clock output on/off control only
1	GSM mode smart card interface mode operation <ul style="list-style-type: none"> • TEND flag generated 11.0 etu after beginning of start bit • Fixed high/low-level control possible (set in SCR) in addition to clock output on/off control

Note: etu (Elementary Time Unit): Interval for transfer of one bit

Bit	:	7	6	5	4	3	2	1	0
Initial value	:	1	1	1	1	1	1	1	1
Read/Write	:	R/W	R/W	R/W	R/W	R/W	R/W	R/W	R/W

Sets the serial transfer bit rate

Note: See section 12.2.8, Bit Rate Register (BRR), for details.

Bit	:	7	6	5	4	3	2	1	0
		TIE	RIE	TE	RE	MPIE	TEIE	CKE1	CKE0
Initial value	:	0	0	0	0	0	0	0	0
Read/Write	:	R/W	R/W	R/W	R/W	R/W	R/W	R/W	R/W

Clock Enable

0	0	Asynchronous mode	Internal clock/SCK pin functions as I/O port
	1	Synchronous mode	Internal clock/SCK pin functions as serial clock output
1	0	Asynchronous mode	Internal clock/SCK pin functions as clock output*1
	1	Synchronous mode	Internal clock/SCK pin functions as serial clock output
1	0	Asynchronous mode	External clock/SCK pin functions as clock input*2
	1	Synchronous mode	External clock/SCK pin functions as serial clock input
1	0	Asynchronous mode	External clock/SCK pin functions as clock input*2
	1	Synchronous mode	External clock/SCK pin functions as serial clock input

Notes: 1. Outputs a clock of the same frequency as the bit rate.

2. Inputs a clock with a frequency 16 times the bit rate.

Transmit End Interrupt Enable

0	Transmit end interrupt (TEI) request disabled
1	Transmit end interrupt (TEI) request enabled

Multiprocessor Interrupt Enable

0	Multiprocessor interrupts disabled [Clearing conditions] • When the MPIE bit is cleared to 0 • When MPB= 1 data is received
1	Multiprocessor interrupts enabled Receive interrupt (RXI) requests, receive error interrupt (ERI) requests, and setting of the RDRF, FER, and ORER flags in SSR are disabled until data with the multiprocessor bit set to 1 is received

Receive Enable

0	Reception disabled
1	Reception enabled

Transmit Enable

0	Transmission disabled
1	Transmission enabled

Receive Interrupt Enable

0	Receive data full interrupt (RXI) request and receive error interrupt (ERI) request disabled
1	Receive data full interrupt (RXI) request and receive error interrupt (ERI) request enabled

Transmit Interrupt Enable

0	Transmit data empty interrupt (TXI) requests disabled
1	Transmit data empty interrupt (TXI) requests enabled

Bit	:	7	6	5	4	3	2	1	0
		TIE	RIE	TE	RE	MPIE	TEIE	CKE1	CKE0
Initial value	:	0	0	0	0	0	0	0	0
Read/Write	:	R/W	R/W	R/W	R/W	R/W	R/W	R/W	R/W

Clock Enable				
SMCR	SMR	SCR setting		SCK pin function
SMIF	C/A, GM	CKE1	CKE0	
0	See SCI specification			
1	0	0	0	Operates as port input pin
1	0	0	1	Clock output as SCK output pin
1	1	0	0	Fixed-low output as SCK output pin
1	1	0	1	Clock output as SCK output pin
1	1	1	0	Fixed-high output as SCK output pin
1	1	1	1	Clock output as SCK output pin

Transmit End Interrupt Enable	
0	Transmit end interrupt (TEI) request disabled
1	Transmit end interrupt (TEI) request enabled

Multiprocessor Interrupt Enable	
0	Multiprocessor interrupts disabled [Clearing conditions] • When the MPIE bit is cleared to 0 • When MPB= 1 data is received
1	Multiprocessor interrupts enabled Receive interrupt (RXI) requests, receive error interrupt (ERI) requests, and setting of the RDRF, FER, and ORER flags in SSR are disabled until data with the multiprocessor bit set to 1 is received

Receive Enable	
0	Reception disabled
1	Reception enabled

Transmit Enable	
0	Transmission disabled
1	Transmission enabled

Receive Interrupt Enable	
0	Receive data full interrupt (RXI) request and receive error interrupt (ERI) request disabled
1	Receive data full interrupt (RXI) request and receive error interrupt (ERI) request enabled

Transmit Interrupt Enable	
0	Transmit data empty interrupt (TXI) requests disabled
1	Transmit data empty interrupt (TXI) requests enabled

Bit	:	7	6	5	4	3	2	1	0
Initial value	:	1	1	1	1	1	1	1	1
Read/Write	:	R/W	R/W	R/W	R/W	R/W	R/W	R/W	R/W

Stores data for serial transmission

Bit	:	7	6	5	4	3	2	1	0
		TDRE	RDRF	ORER	FER	PER	TEND	MPB	MPBT
Initial value	:	1	0	0	0	0	1	0	0
Read/Write	:	R/(W)*	R/(W)*	R/(W)*	R/(W)*	R/(W)*	R	R	R/W

Multiprocessor Bit Transfer

0	Data with a 0 multiprocessor bit is transmitted
1	Data with a 1 multiprocessor bit is transmitted

Multiprocessor Bit

0	[Clearing condition] When data with a 0 multiprocessor bit is received
1	[Setting condition] When data with a 1 multiprocessor bit is received

Transmit End

0	[Clearing condition] • When 0 is written to TDRE after reading TDRE = 1 • When the DTC is activated by a TXI interrupt and writes data to TDR
1	[Setting condition] • When the TE bit in SCR is 0 • When TDRE = 1 at transmission of the last bit of a 1-byte serial transmit character

Parity Error

0	[Clearing condition] When 0 is written to PER after reading PER = 1
1	[Setting condition] When, in reception, the number of 1 bits in the receive data plus the parity bit does not match the parity setting (even or odd) specified by the O/E bit in SMR

Framing Error

0	[Clearing condition] When 0 is written to FER after reading FER = 1
1	[Setting condition] When the SCI checks whether the stop bit at the end of the receive data when reception ends, and the stop bit is 0

Overrun Error

0	[Clearing condition] When 0 is written to ORER after reading ORER = 1
1	[Setting condition] When the next serial reception is completed while RDRF = 1

Receive Data Register Full

0	[Clearing condition] • When 0 is written to RDRF after reading RDRF = 1 • When the DTC is activated by an RXI interrupt and reads data from RDR
1	[Setting condition] When serial reception ends normally and receive data is transferred from RSR to RDR

Transmit Data Register Empty

0	[Clearing condition] • When 0 is written to TDRE after reading TDRE = 1 • When the DTC is activated by a TXI interrupt and writes data to TDR
1	[Setting condition] • When the TE bit in SCR is 0 • When data is transferred from TDR to TSR and data can be written to TDR

Note: * Can only be written with 0 for flag clearing.

Bit	7	6	5	4	3	2	1	0
	TDRE	RDRF	ORER	ERS	PER	TEND	MPB	MPBT
Initial value :	1	0	0	0	0	1	0	0
Read/Write :	R/(W)*	R/(W)*	R/(W)*	R/(W)*	R/(W)*	R	R	R/W

Multiprocessor Bit Transfer

0	Data with a 0 multiprocessor bit is transmitted
1	Data with a 1 multiprocessor bit is transmitted

Multiprocessor Bit

0	[Clearing condition] When data with a 0 multiprocessor bit is received
1	[Setting conditions] When data with a 1 multiprocessor bit is received

Transmit End

0	[Clearing condition] • When 0 is written to TDRE after reading TDRE = 1 • When the DTC is activated by a TXI interrupt and writes data to TDR
1	[Setting conditions] • On reset, or in standby mode or module stop mode • When the TE bit in SCR is 0 and the ERS bit is 0 • When TDRE = 1 and ERS = 0 (normal transmission) 2.5 etu after a 1-byte serial character is sent when GM = 0 • When TDRE = 1 and ERS = 0 (normal transmission) 1.0 etu after a 1-byte serial character is sent when GM = 1

Note: etu: Elementary Time Unit (the time taken to transmit one bit)

Parity Error

0	[Clearing condition] When 0 is written to PER after reading PER = 1
1	[Setting condition] When, in reception, the number of 1 bits in the receive data plus the parity bit does not match the parity setting (even or odd) specified by the O/E bit in SMR

Error Signal Status

0	[Clearing condition] • On reset, or in standby mode or module stop mode • When 0 is written to ERS after reading ERS = 1
1	[Setting conditions] When the error signal is sampled at the low level

Note: Clearing the TE bit in SCR to 0 does not affect the ERS flag, which retains its prior state.

Overrun Error

0	[Clearing condition] When 0 is written to ORER after reading ORER = 1
1	[Setting condition] When the next serial reception is completed while RDRF = 1

Receive Data Register Full

0	[Clearing condition] • When 0 is written to RDRF after reading RDRF = 1 • When the DTC is activated by an RXI interrupt and reads data from RDR
1	[Setting condition] When serial reception ends normally and receive data is transferred from RSR to RDR

Transmit Data Register Empty

0	[Clearing condition] • When 0 is written to TDRE after reading TDRE = 1 • When the DTC is activated by a TXI interrupt and writes data to TDR
1	[Setting condition] • When the TE bit in SCR is 0 • When data is transferred from TDR to TSR and data can be written to TDR

Note: * Can only be written with 0 for flag clearing.

RDR1—Receive Data Register 1**H'FF85 SCI1, Smart Card Interface 1**

Bit	:	7	6	5	4	3	2	1	0
Initial value	:	0	0	0	0	0	0	0	0
Read/Write	:	R	R	R	R	R	R	R	R

Stores received serial data

SCMR1—Smart Card Mode Register 1**H'FF86 SCI1, Smart Card Interface 1**

Bit	:	7	6	5	4	3	2	1	0
Initial value	:	—	—	—	—	SDIR	SINV	—	SMIF
Read/Write	:	—	—	—	—	R/W	R/W	—	R/W

Smart Card
Interface Mode Select

0	Smart Card interface function is disabled
1	Smart Card interface function is enabled

Smart Card Data Invert

0	TDR contents are transmitted as they are Receive data is stored in RDR as it is
1	TDR contents are inverted before being transmitted Receive data is stored in RDR in inverted form

Smart Card Data Direction

0	TDR contents are transmitted LSB-first Receive data is stored in RDR LSB-first
1	TDR contents are transmitted MSB-first Receive data is stored in RDR MSB-first

Bit	:	7	6	5	4	3	2	1	0
		C/ \bar{A}	CHR	PE	O/ \bar{E}	STOP	MP	CKS1	CKS0
Initial value	:	0	0	0	0	0	0	0	0
Read/Write	:	R/W	R/W	R/W	R/W	R/W	R/W	R/W	R/W

Clock Select

0	0	\emptyset clock
	1	$\emptyset/4$ clock
1	0	$\emptyset/16$ clock
	1	$\emptyset/64$ clock

Multiprocessor Mode

0	Multiprocessor function disabled
1	Multiprocessor format selected

Stop Bit Length

0	1 stop bit
1	2 stop bits

Parity Mode

0	Even parity
1	Odd parity

Parity Enable

0	Parity bit addition and checking disabled
1	Parity bit addition and checking enabled

Character Length

0	8-bit data
1	7-bit data*

Note: * When 7-bit data is selected, the MSB (bit 7) of TDR is not transmitted.

Asynchronous Mode/Synchronous Mode Select

0	Asynchronous mode
1	Synchronous mode

Bit	:	7	6	5	4	3	2	1	0
		GM	CHR	PE	O/E	STOP	MP	CKS1	CKS0

Initial value : 0 0 0 0 0 0 0 0 0

Read/Write : R/W R/W R/W R/W R/W R/W R/W R/W

Clock Select

0	0	∅ clock
	1	∅/4 clock
1	0	∅/16 clock
	1	∅/64 clock

Multiprocessor Mode

0	Multiprocessor function disabled
1	Setting prohibited

Stop Bit Length

0	Setting prohibited
1	2 stop bits

Parity Mode

0	Even parity
1	Odd parity

Parity Enable

0	Setting prohibited
1	Parity bit addition and checking enabled

Character Length

0	8-bit data
1	Setting prohibited

GSM Mode _____

0	Normal smart card interface mode operation <ul style="list-style-type: none"> • TEND flag generated 12.5 etu after beginning of start bit • Clock output on/off control only
1	GSM mode smart card interface mode operation <ul style="list-style-type: none"> • TEND flag generated 11.0 etu after beginning of start bit • Fixed high/low-level control possible (set in SCR) in addition to clock output on/off control

Note: etu (Elementary Time Unit): Interval for transfer of one bit

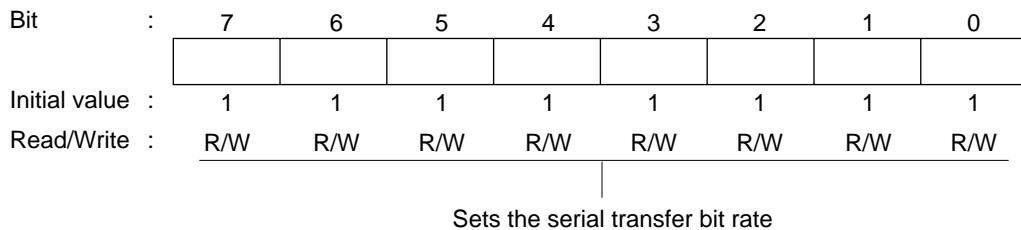

Note: See section 12.2.8, Bit Rate Register (BRR), for details.

Bit	:	7	6	5	4	3	2	1	0
		TIE	RIE	TE	RE	MPIE	TEIE	CKE1	CKE0
Initial value	:	0	0	0	0	0	0	0	0
Read/Write	:	R/W	R/W	R/W	R/W	R/W	R/W	R/W	R/W

Clock Enable

0	0	Asynchronous mode	Internal clock/SCK pin functions as I/O port
		Synchronous mode	Internal clock/SCK pin functions as serial clock output
	1	Asynchronous mode	Internal clock/SCK pin functions as clock output*1
		Synchronous mode	Internal clock/SCK pin functions as serial clock output
1	0	Asynchronous mode	External clock/SCK pin functions as clock input*2
		Synchronous mode	External clock/SCK pin functions as serial clock input
	1	Asynchronous mode	External clock/SCK pin functions as clock input*2
		Synchronous mode	External clock/SCK pin functions as serial clock input

Notes: 1. Outputs a clock of the same frequency as the bit rate.
2. Inputs a clock with a frequency 16 times the bit rate.

Transmit End Interrupt Enable

0	Transmit end interrupt (TEI) request disabled
1	Transmit end interrupt (TEI) request enabled

Multiprocessor Interrupt Enable

0	Multiprocessor interrupts disabled [Clearing conditions] • When the MPIE bit is cleared to 0 • When MPB= 1 data is received
1	Multiprocessor interrupts enabled Receive interrupt (RXI) requests, receive error interrupt (ERI) requests, and setting of the RDRF, FER, and ORER flags in SSR are disabled until data with the multiprocessor bit set to 1 is received

Receive Enable

0	Reception disabled
1	Reception enabled

Transmit Enable

0	Transmission disabled
1	Transmission enabled

Receive Interrupt Enable

0	Receive data full interrupt (RXI) request and receive error interrupt (ERI) request disabled
1	Receive data full interrupt (RXI) request and receive error interrupt (ERI) request enabled

Transmit Interrupt Enable

0	Transmit data empty interrupt (TXI) requests disabled
1	Transmit data empty interrupt (TXI) requests enabled

Bit	:	7	6	5	4	3	2	1	0
		TIE	RIE	TE	RE	MPIE	TEIE	CKE1	CKE0
Initial value :		0	0	0	0	0	0	0	0
Read/Write :		R/W	R/W	R/W	R/W	R/W	R/W	R/W	R/W

Clock Enable

SMCR	SMR	SCR setting		SCK pin function
SMIF	C/Ā,GM	CKE1	CKE0	
0	See SCI specification			
1	0	0	0	Operates as port input pin
1	0	0	1	Clock output as SCK output pin
1	1	0	0	Fixed-low output as SCK output pin
1	1	0	1	Clock output as SCK output pin
1	1	1	0	Fixed-high output as SCK output pin
1	1	1	1	Clock output as SCK output pin

Transmit End Interrupt Enable

0	Transmit end interrupt (TEI) request disabled
1	Transmit end interrupt (TEI) request enabled

Multiprocessor Interrupt Enable

0	Multiprocessor interrupts disabled [Clearing conditions] • When the MPIE bit is cleared to 0 • When MPB= 1 data is received
1	Multiprocessor interrupts enabled Receive interrupt (RXI) requests, receive error interrupt (ERI) requests, and setting of the RDRF, FER, and ORER flags in SSR are disabled until data with the multiprocessor bit set to 1 is received

Receive Enable

0	Reception disabled
1	Reception enabled

Transmit Enable

0	Transmission disabled
1	Transmission enabled

Receive Interrupt Enable

0	Receive data full interrupt (RXI) request and receive error interrupt (ERI) request disabled
1	Receive data full interrupt (RXI) request and receive error interrupt (ERI) request enabled

Transmit Interrupt Enable

0	Transmit data empty interrupt (TXI) requests disabled
1	Transmit data empty interrupt (TXI) requests enabled

Bit	:	7	6	5	4	3	2	1	0
Initial value	:	1	1	1	1	1	1	1	1
Read/Write	:	R/W	R/W	R/W	R/W	R/W	R/W	R/W	R/W

Stores data for serial transmission

Bit	:	7	6	5	4	3	2	1	0
		TDRE	RDRF	ORER	FER	PER	TEND	MPB	MPBT
Initial value	:	1	0	0	0	0	1	0	0
Read/Write	:	R/(W)*	R/(W)*	R/(W)*	R/(W)*	R/(W)*	R	R	R/W

Multiprocessor Bit Transfer

0	Data with a 0 multiprocessor bit is transmitted
1	Data with a 1 multiprocessor bit is transmitted

Multiprocessor Bit

0	[Clearing condition] When data with a 0 multiprocessor bit is received
1	[Setting condition] When data with a 1 multiprocessor bit is received

Transmit End

0	[Clearing condition] • When 0 is written to TDRE after reading TDRE = 1 • When the DTC is activated by a TXI interrupt and writes data to TDR
1	[Setting condition] • When the TE bit in SCR is 0 • When TDRE = 1 at transmission of the last bit of a 1-byte serial transmit character

Parity Error

0	[Clearing condition] When 0 is written to FER after reading FER = 1
1	[Setting condition] When, in reception, the number of 1 bits in the receive data plus the parity bit does not match the parity setting (even or odd) specified by the O/E bit in SMR

Framing Error

0	[Clearing condition] When 0 is written to FER after reading FER = 1
1	[Setting condition] When the SCI checks whether the stop bit at the end of the receive data when reception ends, and the stop bit is 0

Overrun Error

0	[Clearing condition] When 0 is written to ORER after reading ORER = 1
1	[Setting condition] When the next serial reception is completed while RDRF = 1

Receive Data Register Full

0	[Clearing condition] • When 0 is written to RDRF after reading RDRF = 1 • When the DTC is activated by an RXI interrupt and reads data from RDR
1	[Setting condition] When serial reception ends normally and receive data is transferred from RSR to RDR

Transmit Data Register Empty

0	[Clearing condition] • When 0 is written to TDRE after reading TDRE = 1 • When the DTC is activated by a TXI interrupt and writes data to TDR
1	[Setting condition] • When the TE bit in SCR is 0 • When data is transferred from TDR to TSR and data can be written to TDR

Note: * Can only be written with 0 for flag clearing.

Bit	7	6	5	4	3	2	1	0
	TDRE	RDRF	ORER	ERS	PER	TEND	MPB	MPBT
Initial value	1	0	0	0	0	1	0	0
Read/Write	R/(W)*	R/(W)*	R/(W)*	R/(W)*	R/(W)*	R	R	R/W

Multiprocessor Bit Transfer

0	Data with a 0 multiprocessor bit is transmitted
1	Data with a 1 multiprocessor bit is transmitted

Multiprocessor Bit

0	[Clearing condition] When data with a 0 multiprocessor bit is received
1	[Setting condition] When data with a 1 multiprocessor bit is received

Transmit End

0	[Clearing condition] • When 0 is written to TDRE after reading TDRE = 1 • When the DTC is activated by a TXI interrupt and writes data to TDR
1	[Setting conditions] • On reset, or in standby mode or module stop mode • When the TE bit in SCR is 0 • When TDRE = 1 and ERS = 0 (normal transmission) 2.5 etu after a 1-byte serial character is sent when GM = 0 • When TDRE = 1 and ERS = 0 (normal transmission) 1.0 etu after a 1-byte serial character is sent when GM = 1

Note: etu: Elementary Time Unit (the time taken to transmit one bit)

Parity Error

0	[Clearing condition] When 0 is written to PER after reading PER = 1
1	[Setting condition] When, in reception, the number of 1 bits in the receive data plus the parity bit does not match the parity setting (even or odd) specified by the O/E bit in SMR

Error Signal Status

0	[Clearing condition] • On reset, or in standby mode or module stop mode • When 0 is written to ERS after reading ERS = 1
1	[Setting conditions] When the error signal is sampled at the low level

Note: Clearing the TE bit in SCR to 0 does not affect the ERS flag, which retains its prior state.

Overrun Error

0	[Clearing condition] When 0 is written to ORER after reading ORER = 1
1	[Setting condition] On of the next serial reception when RDRF= 1 completion

Receive Data Register Full

0	[Clearing condition] • When 0 is written to RDRF after reading RDRF = 1 • When the DTC is activated by an RXI interrupt and reads data from RDR
1	[Setting condition] When serial reception ends normally and receive data is transferred from RSR to RDR

Transmit Data Register Empty

0	[Clearing condition] • When 0 is written to TDRE after reading TDRE = 1 • When the DTC is activated by a TXI interrupt and writes data to TDR
1	[Setting condition] • When the TE bit in SCR is 0 • When data is transferred from TDR to TSR and data can be written to TDR

Note: * Can only be written with 0 for flag clearing.

RDR2—Receive Data Register 2**H'FF8D SCI2, Smart Card Interface 2**

Bit	:	7	6	5	4	3	2	1	0
Initial value	:	0	0	0	0	0	0	0	0
Read/Write	:	R	R	R	R	R	R	R	R

Stores received serial data

SCMR2—Smart Card Mode Register 2**H'FF8E SCI2, Smart Card Interface 2**

Bit	:	7	6	5	4	3	2	1	0
		—	—	—	—	SDIR	SINV	—	SMIF
Initial value	:	1	1	1	1	0	0	1	0
Read/Write	:	—	—	—	—	R/W	R/W	—	R/W

Smart Card Interface Mode Select

0	Smart Card interface function is disabled
1	Smart Card interface function is enabled

Smart Card Data Invert

0	TDR contents are transmitted as they are Receive data is stored in RDR as it is
1	TDR contents are inverted before being transmitted Receive data is stored in RDR in inverted form

Smart Card Data Direction

0	TDR contents are transmitted LSB-first Receive data is stored in RDR LSB-first
1	TDR contents are transmitted MSB-first Receive data is stored in RDR MSB-first

ADDRAH	—	A/D Data Register AH	H'FF90	A/D Converter
ADDRAL	—	A/D Data Register AL	H'FF91	A/D Converter
ADDRBH	—	A/D Data Register BH	H'FF92	A/D Converter
ADDRBL	—	A/D Data Register BL	H'FF93	A/D Converter
ADDRCH	—	A/D Data Register CH	H'FF94	A/D Converter
ADDRCL	—	A/D Data Register CL	H'FF95	A/D Converter
ADDRDH	—	A/D Data Register DH	H'FF96	A/D Converter
ADDRDL	—	A/D Data Register DL	H'FF97	A/D Converter

Bit	:	15	14	13	12	11	10	9	8	7	6	5	4	3	2	1	0
		AD9	AD8	AD7	AD6	AD5	AD4	AD3	AD2	AD1	AD0	—	—	—	—	—	—
Initial value	:	0	0	0	0	0	0	0	0	0	0	0	0	0	0	0	0
Read/Write	:	R	R	R	R	R	R	R	R	R	R	R	R	R	R	R	R

Stores the results of A/D conversion

Analog Input Channel		A/D Data Register
Group 0	Group 1	
AN0	AN4	ADDRA
AN1	AN5	ADDRB
AN2	AN6	ADDRC
AN3	AN7	ADDRD

Bit	:	7	6	5	4	3	2	1	0
		ADF	ADIE	ADST	SCAN	CKS	CH2	CH1	CH0
Initial value	:	0	0	0	0	0	0	0	0
Read/Write	:	R/(W)*	R/W	R/W	R/W	R/W	R/W	R/W	R/W

Channel Select

Group select	Channel select			Single Mode	Group Mode
	CH2	CH1	CH0		
0	0	0	0	AN0	AN0
			1	AN1	AN0, AN1
	1	0	0	AN2	AN0 to AN2
			1	AN3	AN0 to AN3
1	0	0	0	AN4	AN4
			1	AN5	AN4, AN5
	1	0	0	AN6	AN4 to AN6
			1	AN7	AN4 to AN7

Group Select

0	Conversion time= 266 states (max.)
1	Conversion time= 134 states (max.)

Scan Mode

0	Single mode
1	Scan mode

A/D Start

0	A/D conversion stopped
1	<ul style="list-style-type: none"> Single mode: A/D conversion is started. Cleared to 0 automatically when conversion ends Scan mode: A/D conversion is started. Conversion continues sequentially on the selected channels until ADST is cleared to 0 by software, a reset, or transition to standby mode or module stop mode

A/D Interrupt Enable

0	A/D conversion end interrupt (ADI) request disabled
1	A/D conversion end interrupt (ADI) request enabled

A/D End Flag

0	[Clearing conditions] <ul style="list-style-type: none"> When 0 is written to the ADF flag after reading ADF = 1 When the DTC is activated by an ADI interrupt, and ADDR is read
1	[Setting conditions] <ul style="list-style-type: none"> Single mode: When A/D conversion ends Scan mode: When one round of conversion has been performed on all specified channels

Note: * Can only be written with 0 for flag clearing.

Bit	:	7	6	5	4	3	2	1	0
		TRGS1	TRGS0	—	—	—	—	—	—
Initial value	:	0	0	1	1	1	1	1	1
Read/Write	:	R/W	R/W	—	—	—	—	—	—

Timer Trigger Select

TRGS1	TRGS0	Description
0	0	A/D conversion start by external trigger is disabled
	1	A/D conversion start by external trigger (TPU) is enabled
1	0	A/D conversion start by external trigger (8-bit timer) is enabled
	1	A/D conversion start by external trigger pin ($\overline{\text{ADTRG}}$) is enabled

DADR0—D/A Data Register 0 (Reserved in H8S/2393) H'FFA4**D/A****DADR1—D/A Data Register 1 (Reserved in H8S/2393) H'FFA5****D/A**

Bit	:	7	6	5	4	3	2	1	0
Initial value	:	0	0	0	0	0	0	0	0
Read/Write	:	R/W	R/W	R/W	R/W	R/W	R/W	R/W	R/W

Stores data for D/A conversion

Bit	:	7	6	5	4	3	2	1	0
		DAOE1	DAOE0	DAE	—	—	—	—	—
Initial value	:	0	0	0	1	1	1	1	1
Read/Write	:	R/W	R/W	R/W	—	—	—	—	—

D/A Output Enable 0

0	Analog output DA0 is disabled
1	Channel 0 D/A conversion is enabled Analog output DA0 is enabled

D/A Output Enable 1

0	Analog output DA1 is disabled
1	Channel 1 D/A conversion is enabled Analog output DA1 is enabled

D/A Conversion Control

DAOE1	DAOE0	DAE	Description
0	0	*	Channel 0 and 1 D/A conversion disabled
		0	Channel 0 D/A conversion enabled Channel 1 D/A conversion disabled
		1	Channel 0 and 1 D/A conversions enabled
1	0	0	Channel 0 D/A conversion disabled Channel 1 D/A conversion enabled
		1	Channel 0 and 1 D/A conversion enabled
	1	*	Channel 0 and 1 D/A conversion enabled

* : Don't care

TCR0—Time Control Register 0
TCR1—Time Control Register 1

H'FFB0
H'FFB1

8-Bit Timer Channel 0
8-Bit Timer Channel 1

Bit	7	6	5	4	3	2	1	0
	CMIEB	CMIEA	OVIE	CCLR1	CCLR0	CKS2	CKS1	CKS0
Initial value :	0	0	0	0	0	0	0	0
Read/Write :	R/W	R/W	R/W	R/W	R/W	R/W	R/W	R/W

Clock Select

0	0	0	Clock input disabled
		1	Internal clock: counted at falling edge of $\phi/8$
	1	0	Internal clock: counted at falling edge of $\phi/64$
		1	Internal clock: counted at falling edge of $\phi/8192$
1	0	0	For channel 0: Count at TCNT1 overflow signal* For channel 1: Count at TCNT0 compare match A*
		1	External clock: counted at rising edge
	1	0	External clock: counted at falling edge
		1	External clock: counted at both rising and falling edges

Note: * If the count input of channel 0 is the TCNT1 overflow signal and that of channel 1 is the TCNT0 compare match signal, no incrementing clock is generated. Do not use this setting.

Counter Clear

0	0	Clear is disabled
	1	Clear by compare match A
1	0	Clear by compare match B
	1	Clear by rising edge of external reset input

Timer Overflow Interrupt Enable

0	OVF interrupt requests (OVI) are disabled
1	OVF interrupt requests (OVI) are enabled

Compare Match Interrupt Enable A

0	CMFA interrupt requests (CMIA) are disabled
1	CMFA interrupt requests (CMIA) are enabled

Compare Match Interrupt Enable B

0	CMFB interrupt requests (CMIB) are disabled
1	CMFB interrupt requests (CMIB) are enabled

TCSR0 Bit	:	7	6	5	4	3	2	1	0
		CMFB	CMFA	OVF	ADTE	OS3	OS2	OS1	OS0
Initial value :		0	0	0	0	0	0	0	0
Read/Write :		R/(W)*	R/(W)*	R/(W)*	R/W	R/W	R/W	R/W	R/W

TCSR1 Bit	:	7	6	5	4	3	2	1	0
		CMFB	CMFA	OVF	—	OS3	OS2	OS1	OS0
Initial value :		0	0	0	1	0	0	0	0
Read/Write :		R/(W)*	R/(W)*	R/(W)*	—	R/W	R/W	R/W	R/W

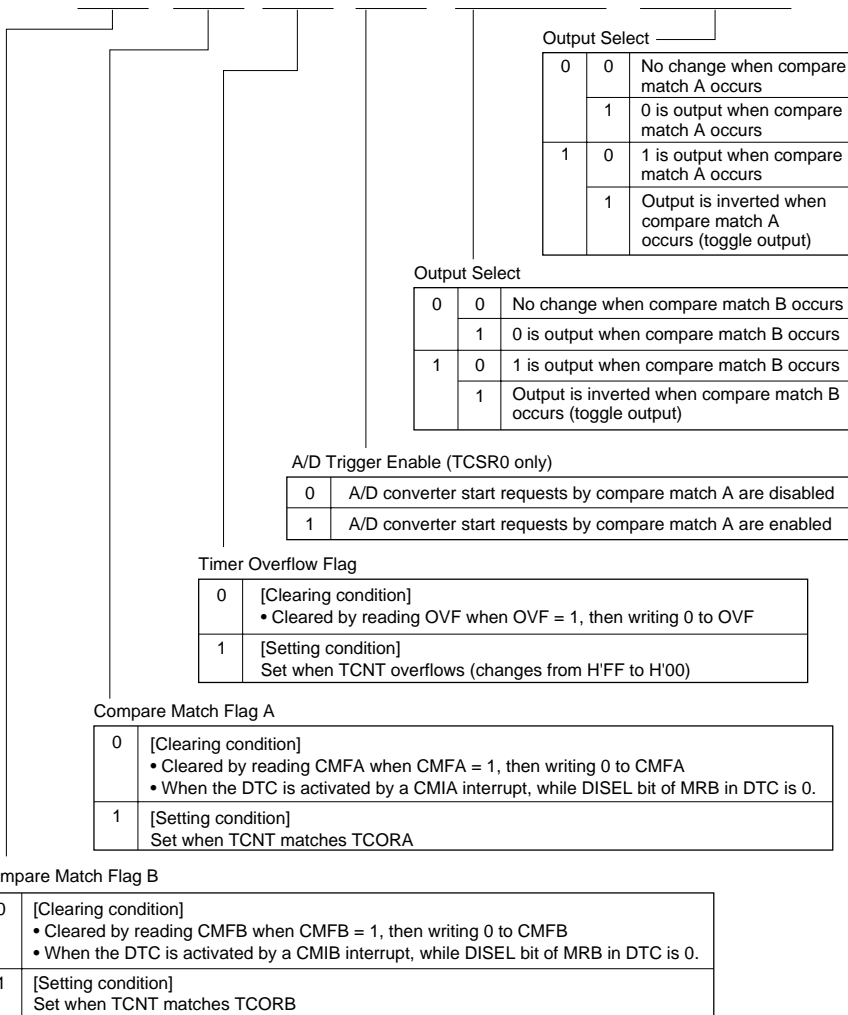

Note: * Only 0 can be written to bits 7 to 5, to clear these flags.

TCORA0—Time Constant Register A0

H'FFB4

8-Bit Timer Channel 0

TCORA1—Time Constant Register A1

H'FFB5

8-Bit Timer Channel 1

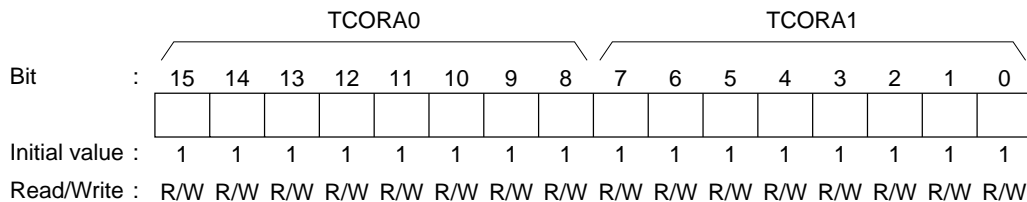

TCORB0—Time Constant Register B0

H'FFB6

8-Bit Timer Channel 0

TCORB1—Time Constant Register B1

H'FFB7

8-Bit Timer Channel 1

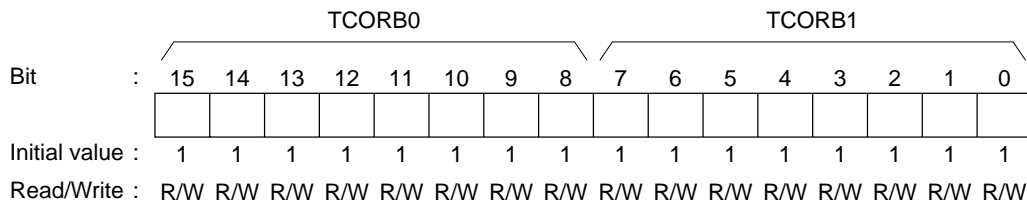

TCNT0—Timer Counter 0

H'FFB8

8-Bit Timer Channel 0

TCNT1—Timer Counter 1

H'FFB9

8-Bit Timer Channel 1

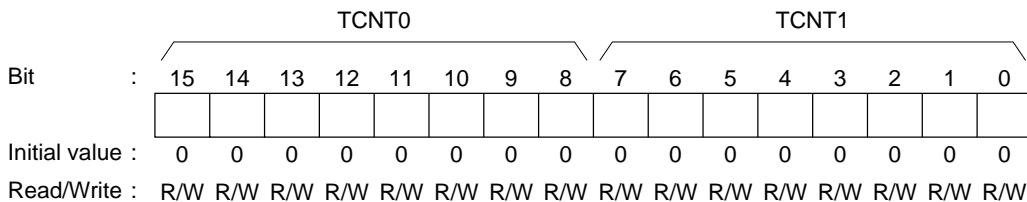

Bit	:	7	6	5	4	3	2	1	0
		OVF	WT/ \overline{IT}	TME	—	—	CKS2	CKS1	CKS0
Initial value :		0	0	0	1	1	0	0	0
Read/Write :		R/(W)*	R/W	R/W	—	—	R/W	R/W	R/W

Clock Select

CKS2	CKS1	CKS0	Clock	Overflow period* (when $\phi = 20$ MHz)
0	0	0	$\phi/2$ (initial value)	25.6 μ s
		1	$\phi/64$	819.2 μ s
	1	0	$\phi/128$	1.6ms
		1	$\phi/512$	6.6ms
1	0	0	$\phi/2048$	26.2ms
		1	$\phi/8192$	104.9ms
	1	0	$\phi/32768$	419.4ms
		1	$\phi/131072$	1.68s

Note: * The overflow period is the time from when TCNT starts counting up from H'00 until overflow occurs.

Timer Enable

0	TCNT is initialized to H'00 and halted
1	TCNT counts

Timer Mode Select

0	Interval timer mode: Sends the CPU an interval timer interrupt request (WOVI) when TCNT overflows
1	Watchdog timer mode: Generates the \overline{WDTOVF} signal when TCNT overflows

Overflow Flag

0	[Clearing condition] Cleared by reading TCSR when OVF = 1, then writing 0 to OVF
1	[Setting condition] Set when TCNT overflows from H'FF to H'00 in interval timer mode

The method for writing to TCSR is different from that for general registers to prevent accidental overwriting. For details see section 11.2.4, Notes on Register Access.

Note: * Can only be written with 0 for flag clearing.

TCNT—Timer Counter**H'FFBC (W) H'FFBD (R)****WDT**

Bit	:	7	6	5	4	3	2	1	0
Initial value	:	0	0	0	0	0	0	0	0
Read/Write	:	R/W	R/W	R/W	R/W	R/W	R/W	R/W	R/W

RSTCSR—Reset Control/Status Register**H'FFBE (W) H'FFBF (R)****WDT**

Bit	:	7	6	5	4	3	2	1	0
		WOVF	RSTE	RSTS	—	—	—	—	—
Initial value	:	0	0	0	1	1	1	1	1
Read/Write	:	R/(W)*	R/W	R/W	—	—	—	—	—

Reset Select

0	Power-on reset
1	Manual reset

Reset Enable

0	Reset signal is not generated if TCNT overflows*
1	Reset signal is generated if TCNT overflows

Note: * The modules H8S/2355 Series are not reset, but TCNT and TCSR in WDT are reset.

Watchdog Timer Overflow Flag

0	[Clearing condition] Cleared by reading TCSR when WOVF = 1, then writing 0 to WOVF
1	[Setting condition] Set when TCNT overflows (changed from H'FF to H'00) during watchdog timer operation

Note: * Can only be written with 0 for flag clearing.

The method for writing to RSTCSR is different from that for general registers to prevent accidental overwriting. For details see section 11.2.4, Notes on Register Access.

Bit	:	7	6	5	4	3	2	1	0
		—	—	CST5	CST4	CST3	CST2	CST1	CST0
Initial value :		0	0	0	0	0	0	0	0
Read/Write :		—	—	R/W	R/W	R/W	R/W	R/W	R/W

Counter Start

0	TCNTn count operation is stopped
1	TCNTn performs count operation

(n = 5 to 0)

Note: If 0 is written to the CST bit during operation with the TIOC pin designated for output, the counter stops but the TIOC pin output compare output level is retained. If TIOR is written to when the CST bit is cleared to 0, the pin output level will be changed to the set initial output value.

TSYR—Timer Synchro Register

H'FFC1

TPU

Bit	:	7	6	5	4	3	2	1	0
		—	—	SYNC5	SYNC4	SYNC3	SYNC2	SYNC1	SYNC0
Initial value :		0	0	0	0	0	0	0	0
Read/Write :		—	—	R/W	R/W	R/W	R/W	R/W	R/W

Timer Synchronization

0	TCNTn operates independently (TCNT presetting/clearing is unrelated to other channels)
1	TCNTn performs synchronous operation TCNT synchronous presetting/synchronous clearing is possible

(n = 5 to 0)

- Notes:
1. To set synchronous operation, the SYNC bits for at least two channels must be set to 1.
 2. To set synchronous clearing, in addition to the SYNC bit, the TCNT clearing source must also be set by means of bits CCLR2 to CCLR0 in TCR.

Bit	:	7	6	5	4	3	2	1	0
		CCLR2	CCLR1	CCLR0	CKEG1	CKEG0	TPSC2	TPSC1	TPSC0
Initial value :		0	0	0	0	0	0	0	0
Read/Write :		R/W	R/W	R/W	R/W	R/W	R/W	R/W	R/W

Time Prescaler

0	0	0	Internal clock: counts on $\phi/1$
		1	Internal clock: counts on $\phi/4$
	1	0	Internal clock: counts on $\phi/16$
		1	Internal clock: counts on $\phi/64$
1	0	0	External clock: counts on TCLKA pin input
		1	External clock: counts on TCLKB pin input
	1	0	External clock: counts on TCLKC pin input
		1	External clock: counts on TCLKD pin input

Clock Edge

0	0	Count at rising edge
	1	Count at falling edge
1	—	Count at both edges

Counter Clear

0	0	0	TCNT clearing disabled
		1	TCNT cleared by TGRA compare match/input capture
	1	0	TCNT cleared by TGRB compare match/input capture
		1	TCNT cleared by counter clearing for another channel performing synchronous clearing/synchronous operation*1
1	0	0	TCNT clearing disabled
		1	TCNT cleared by TGRC compare match/input capture*2
	1	0	TCNT cleared by TGRD compare match/input capture*2
		1	TCNT cleared by counter clearing for another channel performing synchronous clearing/synchronous operation*1

- Notes: 1. Synchronous operation setting is performed by setting the SYNC bit in TSYR to 1.
2. When TGRC or TGRD is used as a buffer register, TCNT is not cleared because the buffer register setting has priority, and compare match/input capture does not occur.

Bit	:	7	6	5	4	3	2	1	0
		—	—	BFB	BFA	MD3	MD2	MD1	MD0
Initial value :		1	1	0	0	0	0	0	0
Read/Write :		—	—	R/W	R/W	R/W	R/W	R/W	R/W

Mode

0	0	0	0	Normal operation
		1	Reserved	
		1	0	PWM mode 1
			1	PWM mode 2
	1	0	0	Phase counting mode 1
			1	Phase counting mode 2
		1	0	Phase counting mode 3
			1	Phase counting mode 4
1	*	*	*	—

* : Don't care

- Notes: 1. MD3 is a reserved bit. In a write, it should always be written with 0.
2. Phase counting mode cannot be set for channels 0 and 3. In this case, 0 should always be written to MD2.

TGRA Buffer Operation

0	TGRA operates normally
1	TGRA and TGRC used together for buffer operation

TGRB Buffer Operation

0	TGRB operates normally
1	TGRB and TGRD used together for buffer operation

Bit	:	7	6	5	4	3	2	1	0
		IOB3	IOB2	IOB1	IOB0	IOA3	IOA2	IOA1	IOA0
Initial value :		0	0	0	0	0	0	0	0
Read/Write :		R/W	R/W	R/W	R/W	R/W	R/W	R/W	R/W

TGR0A I/O Control

0	0	0	0	TGR0A is output compare register	Output disabled		
					1	Initial output is 0 output	0 output at compare match
						0	1 output at compare match
		1	0		0	Toggle output at compare match	
			1		0	Output disabled	
					1	Initial output is 1 output	0 output at compare match
	1	1	0	1 output at compare match			
			1	Toggle output at compare match			
		1	0	0	TGR0A is input capture register	Capture input source is TIOCA0 pin	Input capture at rising edge
	1					*	Input capture at falling edge
						*	Input capture at both edges
	1		*	*		Capture input source is channel 1/count clock	Input capture at TCNT1 count-up/count-down
*				*			
*			*				

TGR0B I/O Control

* : Don't care

0	0	0	0	TGR0B is output compare register	Output disabled		
					1	Initial output is 0 output	0 output at compare match
						0	1 output at compare match
		1	0		0	Toggle output at compare match	
			1		0	Output disabled	
					1	Initial output is 0 output	0 output at compare match
	1	1	0	1 output at compare match			
			1	Toggle output at compare match			
		1	0	0	TGR0B is input capture register	Capture input source is TIOCB0 pin	Input capture at rising edge
	1					*	Input capture at falling edge
						*	Input capture at both edges
	1		*	*		Capture input source is channel 1/count clock	Input capture at TCNT1 count-up/count-down*1
*				*			
*			*				

* : Don't care

Note: *1. When bits TPSC2 to TPSC0 in TCR1 are set to B'000, and 0/1 is used as the TCNT1 count clock, this setting is invalid and input capture is not generated.

Bit	:	7	6	5	4	3	2	1	0
	:	IOD3	IOD2	IOD1	IOD0	IOC3	IOC2	IOC1	IOC0
Initial value	:	0	0	0	0	0	0	0	0
Read/Write	:	R/W	R/W	R/W	R/W	R/W	R/W	R/W	R/W

TGR0C I/O Control

0	0	0	0	0	TGR0C is output compare register	Output disabled		
						1	0	0 output at compare match
							1	1 output at compare match
	1	0	0	Output disabled				
				1		0	0 output at compare match	
						1	1 output at compare match	
	1	0	0	Output disabled				
				1		0	0 output at compare match	
						1	1 output at compare match	
1	0	0	0	TGR0C is input capture register	Capture input source is TIOCC0 pin			
					1	0	Input capture at rising edge	
						1	Input capture at falling edge	
	1	*	*		Input capture at both edges			
Capture input source is channel 1/count clock								
						Input capture at TCNT1 count-up/count-down		

*: Don't care

Note: When the BFA bit in TMDR0 is set to 1 and TGR0C is used as a buffer register, this setting is invalid and input capture/output compare is not generated.

TGR0D I/O Control

0	0	0	0	TGR0D is output compare register*2	Output disabled		
					1	0	0 output at compare match
						1	1 output at compare match
	1	0	0		Output disabled		
					1	0	0 output at compare match
						1	1 output at compare match
	1	0	0		Output disabled		
					1	0	0 output at compare match
						1	1 output at compare match
1	0	0	TGR0D is input capture register*2	Capture input source is TIOCD0 pin			
				1	0	Input capture at rising edge	
					1	Input capture at falling edge	
	1	*		*	Input capture at both edges		
Capture input source is channel 1/count clock							
						Input capture at TCNT1 count-up/count-down*1	

*: Don't care

- Notes: 1 When bits TPSC2 to TPSC0 in TCR1 are set to B'000, and \emptyset /1 is used as the TCNT1 count clock, this setting is invalid and input capture is not generated.
 2 When the BFB bit in TMDR0 is set to 1 and TGR0D is used as a buffer register, this setting is invalid and input capture/output compare is not generated.

Note: When TGRC or TGRD is designated for buffer operation, this setting is invalid and the register operates as a buffer register.

Bit	:	7	6	5	4	3	2	1	0
		TTGE	—	—	TCIEV	TGIED	TGIEC	TGIEB	TGIEA
Initial value	:	0	1	0	0	0	0	0	0
Read/Write	:	R/W	—	—	R/W	R/W	R/W	R/W	R/W

TGR Interrupt Enable A

0	Interrupt requests (TGIA) by TGFA bit disabled
1	Interrupt requests (TGIA) by TGFA bit enabled

TGR Interrupt Enable B

0	Interrupt requests (TGIB) by TGFB bit disabled
1	Interrupt requests (TGIB) by TGFB bit enabled

TGR Interrupt Enable C

0	Interrupt requests (TGIC) by TGFC bit disabled
1	Interrupt requests (TGIC) by TGFC bit enabled

TGR Interrupt Enable D

0	Interrupt requests (TGID) by TGFD bit disabled
1	Interrupt requests (TGID) by TGFD bit enabled

Overflow Interrupt Enable

0	Interrupt requests (TCIV) by TCFV disabled
1	Interrupt requests (TCIV) by TCFV enabled

A/D Conversion Start Request Enable

0	A/D conversion start request generation disabled
1	A/D conversion start request generation enabled

Bit	:	7	6	5	4	3	2	1	0
		—	—	—	TCFV	TGFD	TGFC	TGFB	TGFA
Initial value	:	1	1	0	0	0	0	0	0
Read/Write	:	—	—	—	R/(W)*	R/(W)*	R/(W)*	R/(W)*	R/(W)*

Input Capture/Output Compare Flag A

0	[Clearing condition] • When DTC is activated by TGIA interrupt while DISEL bit of MRB in DTC is 0 • When 0 is written to TGFA after reading TGFA = 1
1	[Setting conditions] • When TCNT = TGRA while TGRA is functioning as output compare register • When TCNT value is transferred to TGRA by input capture signal while TGRA is functioning as input capture register

Input Capture/Output Compare Flag B

0	[Clearing condition] • When DTC is activated by TGIB interrupt while DISEL bit of MRB in DTC is 0 • When 0 is written to TGFB after reading TGFB = 1
1	[Setting conditions] • When TCNT = TGRB while TGRB is functioning as output compare register • When TCNT value is transferred to TGRB by input capture signal while TGRB is functioning as input capture register

Input Capture/Output Compare Flag C

0	[Clearing condition] • When DTC is activated by TGIC interrupt while DISEL bit of MRB in DTC is 0 • When 0 is written to TGFC after reading TGFC = 1
1	[Setting conditions] • When TCNT = TGRC while TGRC is functioning as output compare register • When TCNT value is transferred to TGRC by input capture signal while TGRC is functioning as input capture register

Input Capture/Output Compare Flag D

0	[Clearing condition] • When DTC is activated by TGID interrupt while DISEL bit of MRB in DTC is 0 • When 0 is written to TGFD after reading TGFD = 1
1	[Setting conditions] • When TCNT = TGRD while TGRD is functioning as output compare register • When TCNT value is transferred to TGRD by input capture signal while TGRD is functioning as input capture register

Overflow Flag

0	[Clearing condition] When 0 is written to TCFV after reading TCFV = 1
1	[Setting conditions] When the TCNT value overflows (changes from H'FFFF to H'0000)

Note: * Can only be written with 0 for flag clearing.

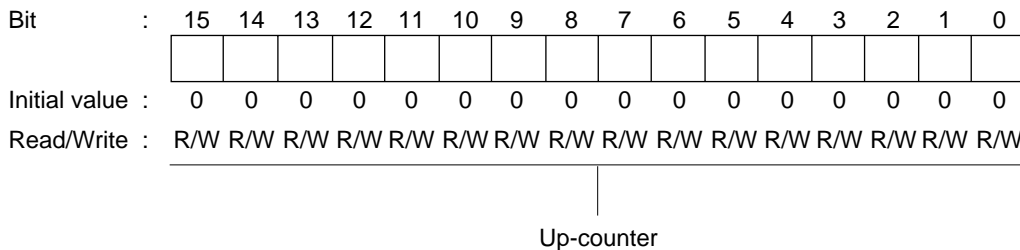

TGR0A—Timer General Register 0A

H'FFD8

TPU0

TGR0B—Timer General Register 0B

H'FFDA

TPU0

TGR0C—Timer General Register 0C

H'FFDC

TPU0

TGR0D—Timer General Register 0D

H'FFDE

TPU0

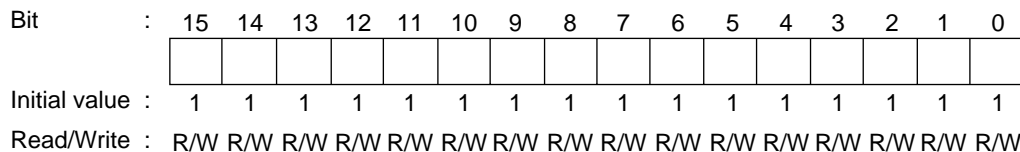

Bit	:	7	6	5	4	3	2	1	0
		—	CCLR1	CCLR0	CKEG1	CKEG0	TPSC2	TPSC1	TPSC0
Initial value	:	0	0	0	0	0	0	0	0
Read/Write	:	—	R/W	R/W	R/W	R/W	R/W	R/W	R/W

Time Prescaler

0	0	0	Internal clock: counts on $\phi/1$
		1	Internal clock: counts on $\phi/4$
1	0	0	Internal clock: counts on $\phi/16$
		1	Internal clock: counts on $\phi/64$
1	0	0	External clock: counts on TCLKA pin input
		1	External clock: counts on TCLKB pin input
	1	0	Internal clock: counts on $\phi/256$
		1	Counts on TCNT2 overflow/underflow

Note: This setting is ignored when channel 1 is in phase counting mode.

Clock Edge

0	0	Count at rising edge
	1	Count at falling edge
1	—	Count at both edges

Note: This setting is ignored when channel 1 is in phase counting mode.

Counter Clear

0	0	TCNT clearing disabled
	1	TCNT cleared by TGRA compare match/input capture
1	0	TCNT cleared by TGRB compare match/input capture
	1	TCNT cleared by counter clearing for another channel performing synchronous clearing/synchronous operation*

Note: * Synchronous operating setting is performed by setting the SYNC bit in TSYR to 1.

Bit	:	7	6	5	4	3	2	1	0
		—	—	—	—	MD3	MD2	MD1	MD0
Initial value	:	1	1	0	0	0	0	0	0
Read/Write	:	—	—	—	—	R/W	R/W	R/W	R/W

Mode

0	0	0	0	Normal operation
		1	Reserved	
		1	0	PWM mode 1
			1	PWM mode 2
	1	0	0	Phase counting mode 1
			1	Phase counting mode 2
		1	0	Phase counting mode 3
			1	1Phase counting mode 4
1	*	*	*	—

*: Don't care

Notes: MD3 is a reserved bit. In a write, it should always be written with 0.

Bit	:	7	6	5	4	3	2	1	0
		IOB3	IOB2	IOB1	IOB0	IOA3	IOA2	IOA1	IOA0
Initial value	:	0	0	0	0	0	0	0	0
Read/Write	:	R/W	R/W	R/W	R/W	R/W	R/W	R/W	R/W

TGR1A I/O Control

0	0	0	0	TGR1A is output compare register	Output disabled				
					1	0	Initial output is 0 output	0 output at compare match	
							1 output at compare match		
		1	0		0	Output disabled			
						1	0	Initial output is 1 output	0 output at compare match
								1 output at compare match	Toggle output at compare match
	1	0	0	TGR1A is input capture register	Capture input source is TIOCA1 pin				
					1	*	Input capture at rising edge	Input capture at falling edge	
							Input capture at both edges		
		1	*		*	Capture input source is TGR0A compare match/ input capture			
						Input capture at generation of channel 0/TGR0A compare match/ input capture			

* : Don't care

TGR1B I/O Control

0	0	0	TGR1B is output compare register	Output disabled					
				1	0	Initial output is 0 output	0 output at compare match		
						1 output at compare match	Toggle output at compare match		
		1		0	0	Output disabled			
						1	0	Initial output is 1 output	0 output at compare match
								1 output at compare match	Toggle output at compare match
	1	0	TGR1B is input capture register	Capture input source is TIOCB1 pin					
				1	*	Input capture at rising edge	Input capture at falling edge		
						Input capture at both edges			
		1		*	*	Capture input source is TGR0C compare match/ input capture			
						Input capture at generation of TGR0B compare match/input capture			

* : Don't care

Bit	7	6	5	4	3	2	1	0
	TTGE	—	TCIEU	TCIEV	—	—	TGIEB	TGIEA
Initial value	0	1	0	0	0	0	0	0
Read/Write	R/W	—	R/W	R/W	—	—	R/W	R/W

TGI Interrupt Enable A

0	Interrupt requests (TGIA) by TGFA bit disabled
1	Interrupt requests (TGIA) by TGFA bit enabled

TGR Interrupt Enable B

0	Interrupt requests (TGIB) by TGFB bit disabled
1	Interrupt requests (TGIB) by TGFB bit enabled

Overflow Interrupt Enable

0	Interrupt requests (TCIV) by TCFV disabled
1	Interrupt requests (TCIV) by TCFV enabled

Underflow Interrupt Enable

0	Interrupt requests (TCIU) by TCFU disabled
1	Interrupt requests (TCIU) by TCFU enabled

A/D Conversion Start Request Enable

0	A/D conversion start request generation disabled
1	A/D conversion start request generation enabled

Bit	:	7	6	5	4	3	2	1	0
		TCFD	—	TCFU	TCFV	—	—	TGFB	TGFA
Initial value	:	1	1	0	0	0	0	0	0
Read/Write	:	R	—	R/(W)*	R/(W)*	—	—	R/(W)*	R/(W)*

Input Capture/Output Compare Flag A

0	[Clearing condition] • When DTC is activated by TGIA interrupt while DISEL bit of MRB in DTC is 0 • When 0 is written to TGFA after reading TGFA = 1
1	[Setting conditions] • When TCNT = TGRA while TGRA is functioning as output compare register • When TCNT value is transferred to TGRA by input capture signal while TGRA is functioning as input capture register

Input Capture/Output Compare Flag B

0	[Clearing condition] • When DTC is activated by TGIB interrupt while DISEL bit of MRB in DTC is 0 • When 0 is written to TGFB after reading TGFB = 1
1	[Setting conditions] • When TCNT = TGRB while TGRB is functioning as output compare register • When TCNT value is transferred to TGRB by input capture signal while TGRB is functioning as input capture register

Overflow Flag

0	[Clearing condition] When 0 is written to TCFV after reading TCFV = 1
1	[Setting conditions] When the TCNT value overflows (changes from H'FFFF to H'0000)

Underflow Flag

0	[Clearing condition] When 0 is written to TCFU after reading TCFU = 1
1	[Setting conditions] When the TCNT value underflows (changes from H'0000 to H'FFFF)

Count Direction Flag

0	TCNT counts down
1	TCNT counts up

Note: * Can only be written with 0 for flag clearing.

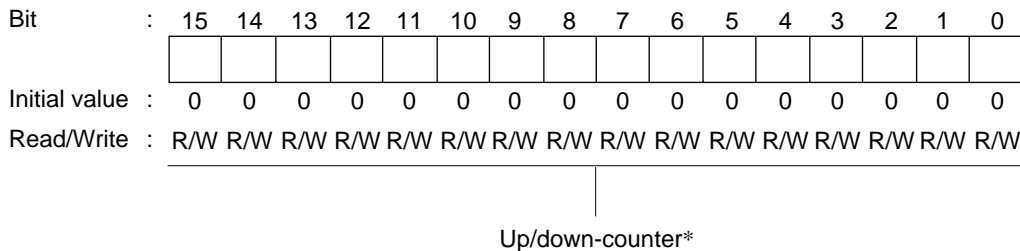

Note: * This timer counter can be used as an up/down-counter only in phase counting mode or when performing overflow/underflow counting on another channel. In other cases it functions as an up-counter.

TGR1A—Timer General Register 1A

H'FFE8

TPU1

TGR1B—Timer General Register 1B

H'FFEA

TPU1

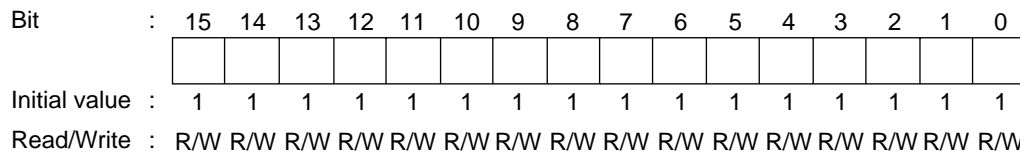

Bit	:	7	6	5	4	3	2	1	0
		—	CCLR1	CCLR0	CKEG1	CKEG0	TPSC2	TPSC1	TPSC0
Initial value	:	0	0	0	0	0	0	0	0
Read/Write	:	—	R/W	R/W	R/W	R/W	R/W	R/W	R/W

Time Prescaler

0	0	0	Internal clock: counts on $\phi/1$
		1	Internal clock: counts on $\phi/4$
	1	0	Internal clock: counts on $\phi/16$
		1	Internal clock: counts on $\phi/64$
1	0	0	External clock: counts on TCLKA pin input
		1	External clock: counts on TCLKB pin input
	1	0	External clock: counts on TCLKC pin input
		1	Internal clock: counts on $\phi/1024$

Note: This setting is ignored when channel 2 is in phase counting mode.

Clock Edge

0	0	Count at rising edge
	1	Count at falling edge
1	—	Count at both edges

Note: This setting is ignored when channel 2 is in phase counting mode.

Counter Clear

0	0	TCNT clearing disabled
	1	TCNT cleared by TGRA compare match/input capture
1	0	TCNT cleared by TGRB compare match/input capture
	1	TCNT cleared by counter clearing for another channel performing synchronous clearing/synchronous operation*

Note: * Synchronous operating setting is performed by setting the SYNC bit TSYR to 1.

Bit	:	7	6	5	4	3	2	1	0
		—	—	—	—	MD3	MD2	MD1	MD0
Initial value	:	1	1	0	0	0	0	0	0
Read/Write	:	—	—	—	—	R/W	R/W	R/W	R/W

Mode

0	0	0	0	Normal operation
		1	Reserved	
		1	0	PWM mode 1
			1	PWM mode 2
	1	0	0	Phase counting mode 1
			1	Phase counting mode 2
		1	0	Phase counting mode 3
			1	Phase counting mode 4
1	*	*	*	—

* : Don't care

Notes: MD3 is a reserved bit. In a write, it should always be written with 0.

Bit	:	7	6	5	4	3	2	1	0
		IOB3	IOB2	IOB1	IOB0	IOA3	IOA2	IOA1	IOA0
Initial value :		0	0	0	0	0	0	0	0
Read/Write :		R/W	R/W	R/W	R/W	R/W	R/W	R/W	R/W

TGR2A I/O Control

0	0	0	0	TGR2A is output compare register	Output disabled				
					1	0	Initial output is 0 output	0 output at compare match	
							1 output at compare match		
		1	0		0	Output disabled			
						1	0	Initial output is 1 output	0 output at compare match
								1 output at compare match	Toggle output at compare match
	1	*	0	0	TGR2A is input capture register	Capture input source is TIOCA2 pin			
						1	*	Input capture at rising edge	Input capture at falling edge
								Input capture at both edges	

* : Don't care

TGR2B I/O Control

0	0	0	0	TGR2B is output compare register	Output disabled				
					1	0	Initial output is 0 output	0 output at compare match	
							1 output at compare match	Toggle output at compare match	
		1	0		0	Output disabled			
						1	0	Initial output is 1 output	0 output at compare match
								1 output at compare match	Toggle output at compare match
	1	*	0	0	TGR2B is input capture register	Capture input source is TIOCB2 pin			
						1	*	Input capture at rising edge	Input capture at falling edge
								Input capture at both edges	

* : Don't care

Bit	:	7	6	5	4	3	2	1	0
		TTGE	—	TCIEU	TCIEV	—	—	TGIEB	TGIEA
Initial value	:	0	1	0	0	0	0	0	0
Read/Write	:	R/W	—	R/W	R/W	—	—	R/W	R/W

TGR Interrupt Enable A

0	Interrupt requests (TGIA) by TGFA bit disabled
1	Interrupt requests (TGIA) by TGFA bit enabled

TGR Interrupt Enable B

0	Interrupt requests (TGIB) by TGFB bit disabled
1	Interrupt requests (TGIB) by TGFB bit enabled

Overflow Interrupt Enable

0	Interrupt requests (TCIV) by TCFV disabled
1	Interrupt requests (TCIV) by TCFV enabled

Underflow Interrupt Enable

0	Interrupt requests (TCIU) by TCFU disabled
1	Interrupt requests (TCIU) by TCFU enabled

A/D Conversion Start Request Enable

0	A/D conversion start request generation disabled
1	A/D conversion start request generation enabled

Bit	:	7	6	5	4	3	2	1	0
		TCFD	—	TCFU	TCFV	—	—	TGFB	TGFA
Initial value	:	1	1	0	0	0	0	0	0
Read/Write	:	R	—	R/(W)*	R/(W)*	—	—	R/(W)*	R/(W)*

Input Capture/Output Compare Flag A

0	[Clearing condition] • When DTC is activated by TGIA interrupt while DISEL bit of MRB in DTC is 0 • When 0 is written to TGFA after reading TGFA = 1
1	[Setting conditions] • When TCNT = TGRA while TGRA is functioning as output compare register • When TCNT value is transferred to TGRA by input capture signal while TGRA is functioning as input capture register

Input Capture/Output Compare Flag B

0	[Clearing condition] • When DTC is activated by TGIB interrupt while DISEL bit of MRB in DTC is 0 • When 0 is written to TGFB after reading TGFB = 1
1	[Setting conditions] • When TCNT = TGRB while TGRB is functioning as output compare register • When TCNT value is transferred to TGRB by input capture signal while TGRB is functioning as input capture register

Overflow Flag

0	[Clearing condition] When 0 is written to TCFV after reading TCFV = 1
1	[Setting conditions] When the TCNT value overflows (changes from H'FFFF to H'0000)

Underflow Flag

0	[Clearing condition] When 0 is written to TCFU after reading TCFU = 1
1	[Setting conditions] When the TCNT value underflows (changes from H'0000 to H'FFFF)

Count Direction Flag

0	TCNT counts down
1	TCNT counts up

Note: * Can only be written with 0 for flag clearing.

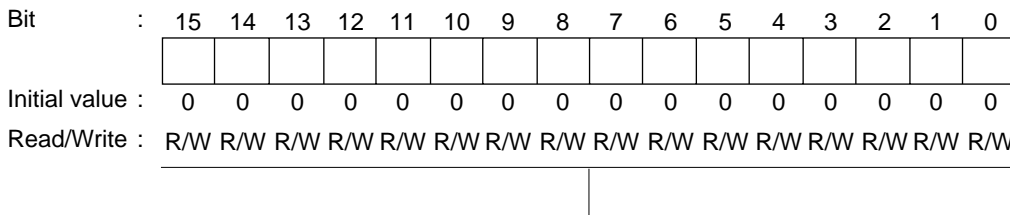

Up/down-counter*

Note: * This timer counter can be used as an up/down-counter only in phase counting mode or when performing overflow/underflow counting on another channel. In other cases it functions as an up-counter.

TGR2A—Timer General Register 2A

H'FFF8

TPU2

TGR2B—Timer General Register 2B

H'FFFA

TPU2

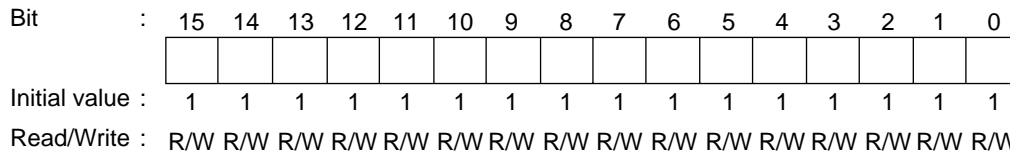

Appendix C I/O Port Block Diagrams

C.1 Port 1 Block Diagram

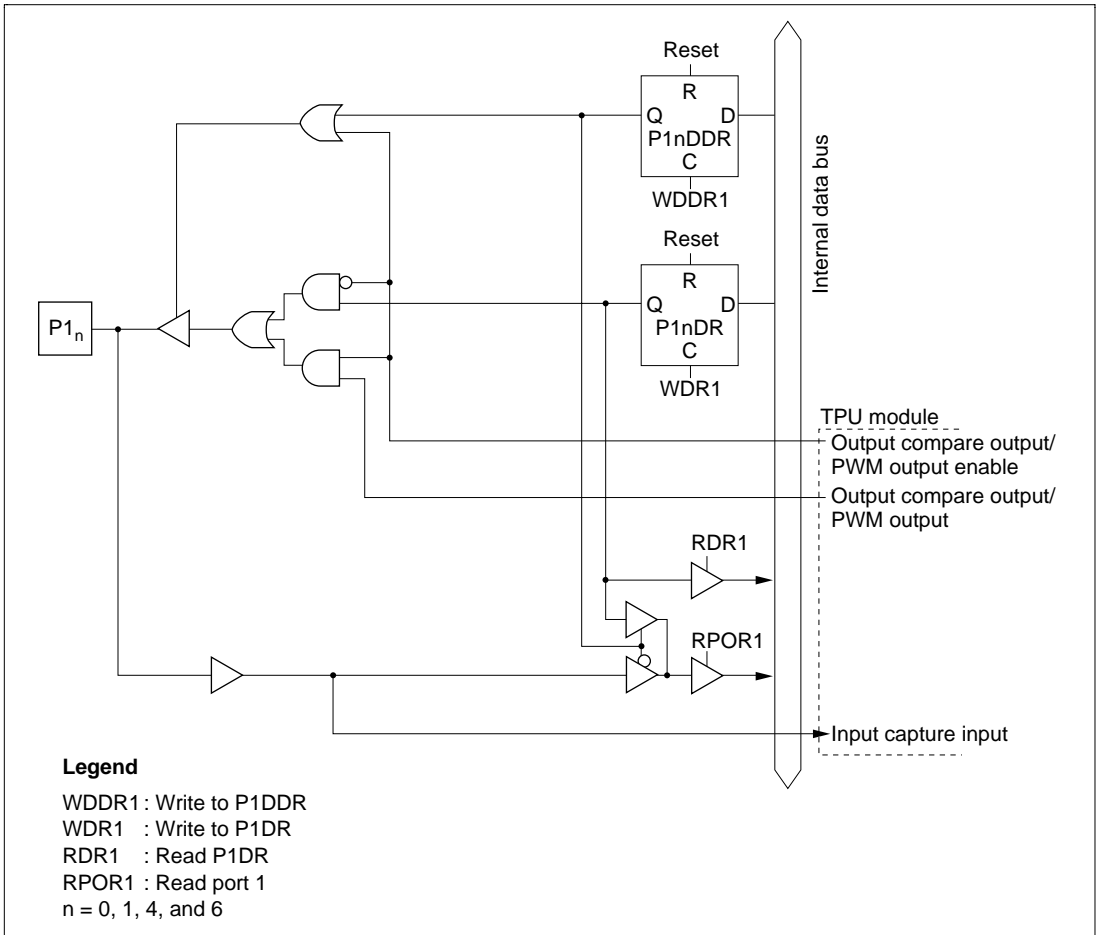

Figure C-1 (a) Port 1 Block Diagram (Pins $P1_0$, $P1_1$, $P1_4$ and $P1_6$)

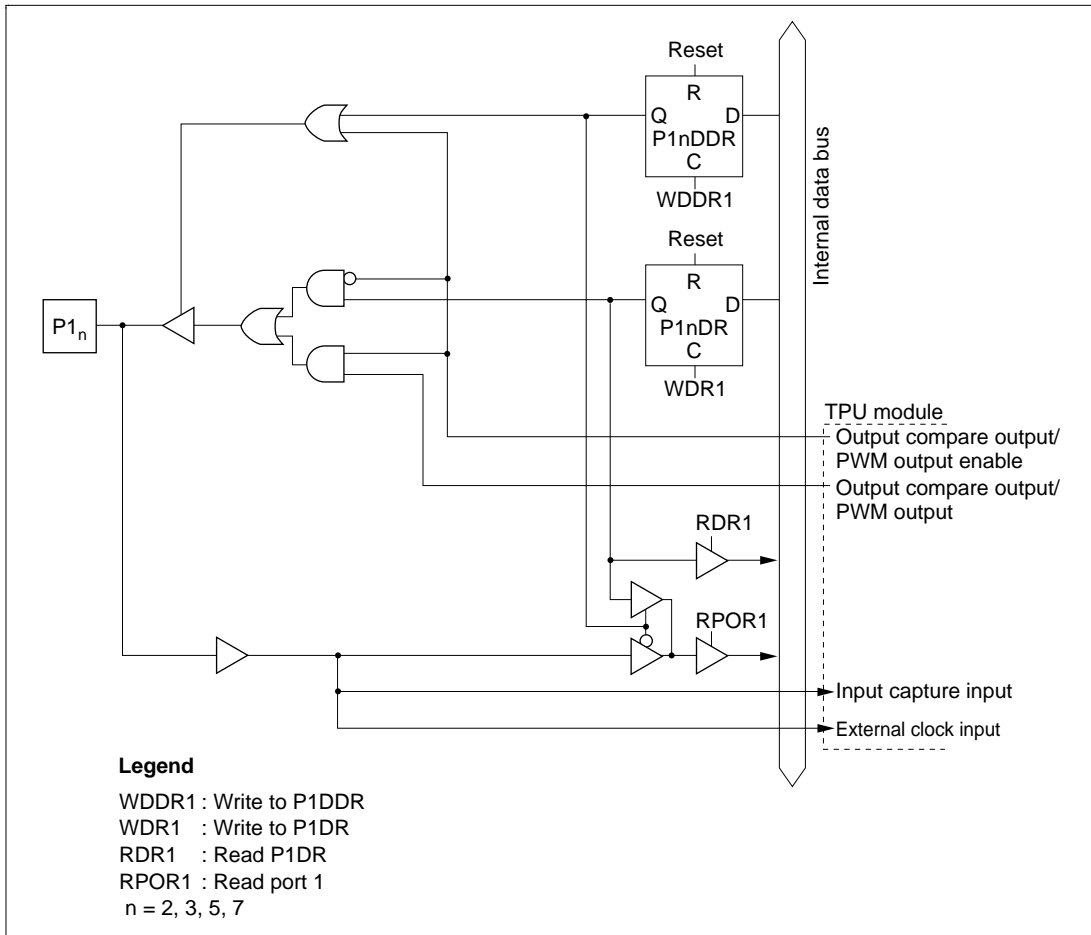

Figure C-1 (b) Port 1 Block Diagram (Pins P1₂, P1₃, P1₅, and P1₇)

C.2 Port 2 Block Diagram

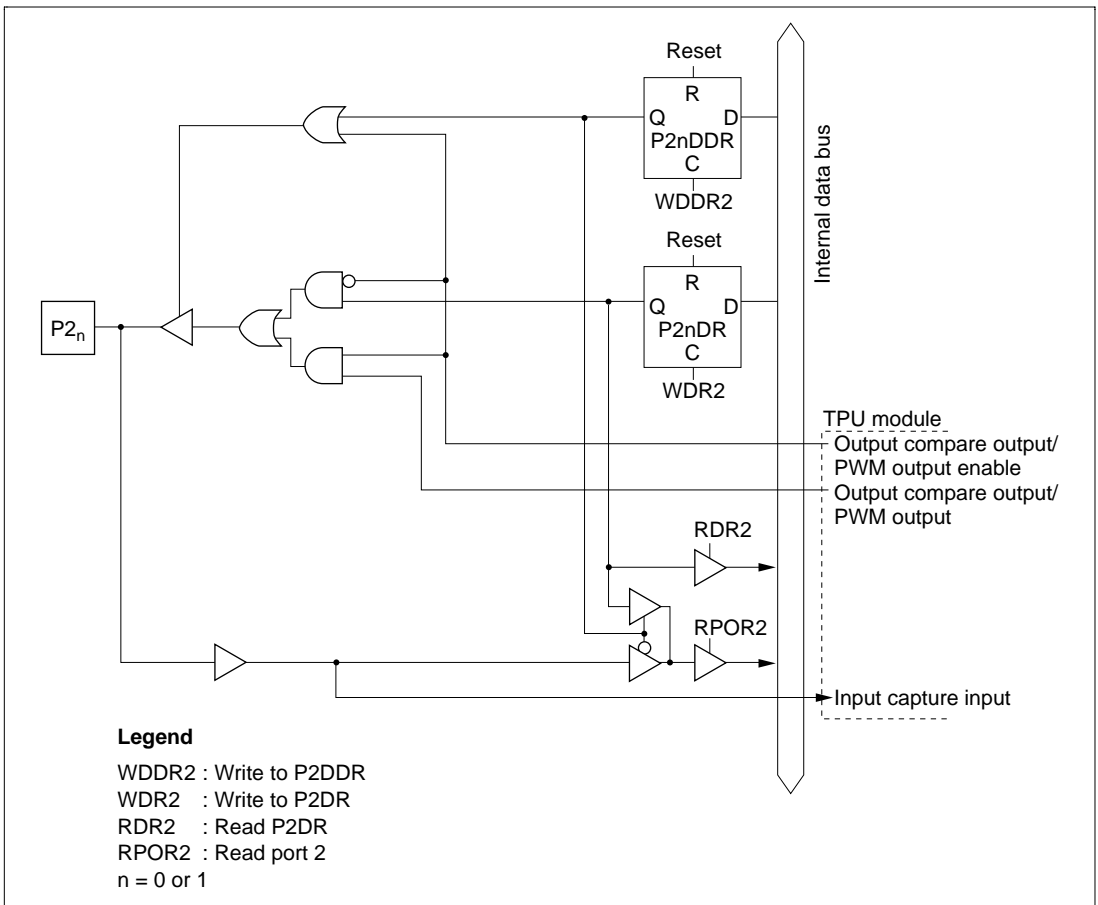

Figure C-2 (a) Port 2 Block Diagram (Pins P2₀ and P2₁)

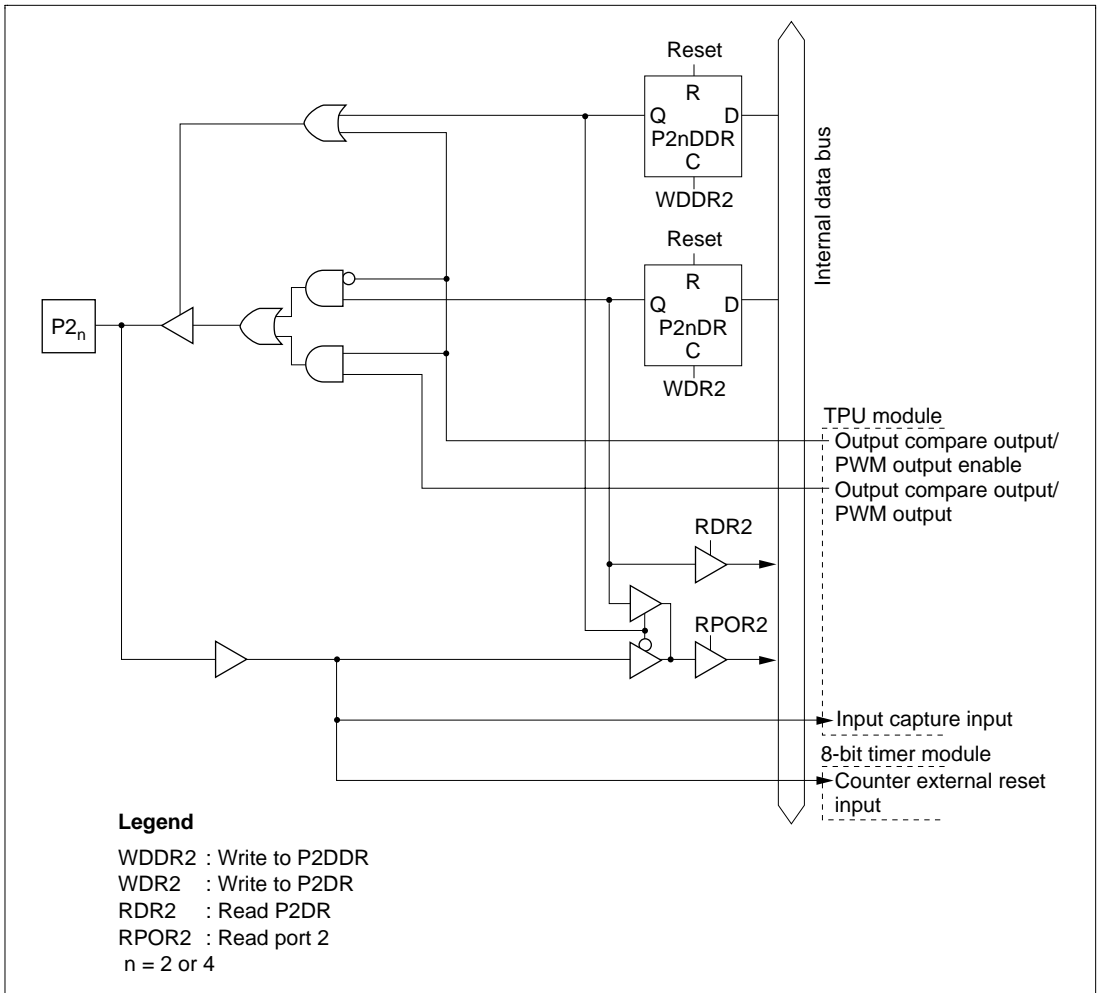

Figure C-2 (b) Port 2 Block Diagram (Pins P₂₂ and P₂₄)

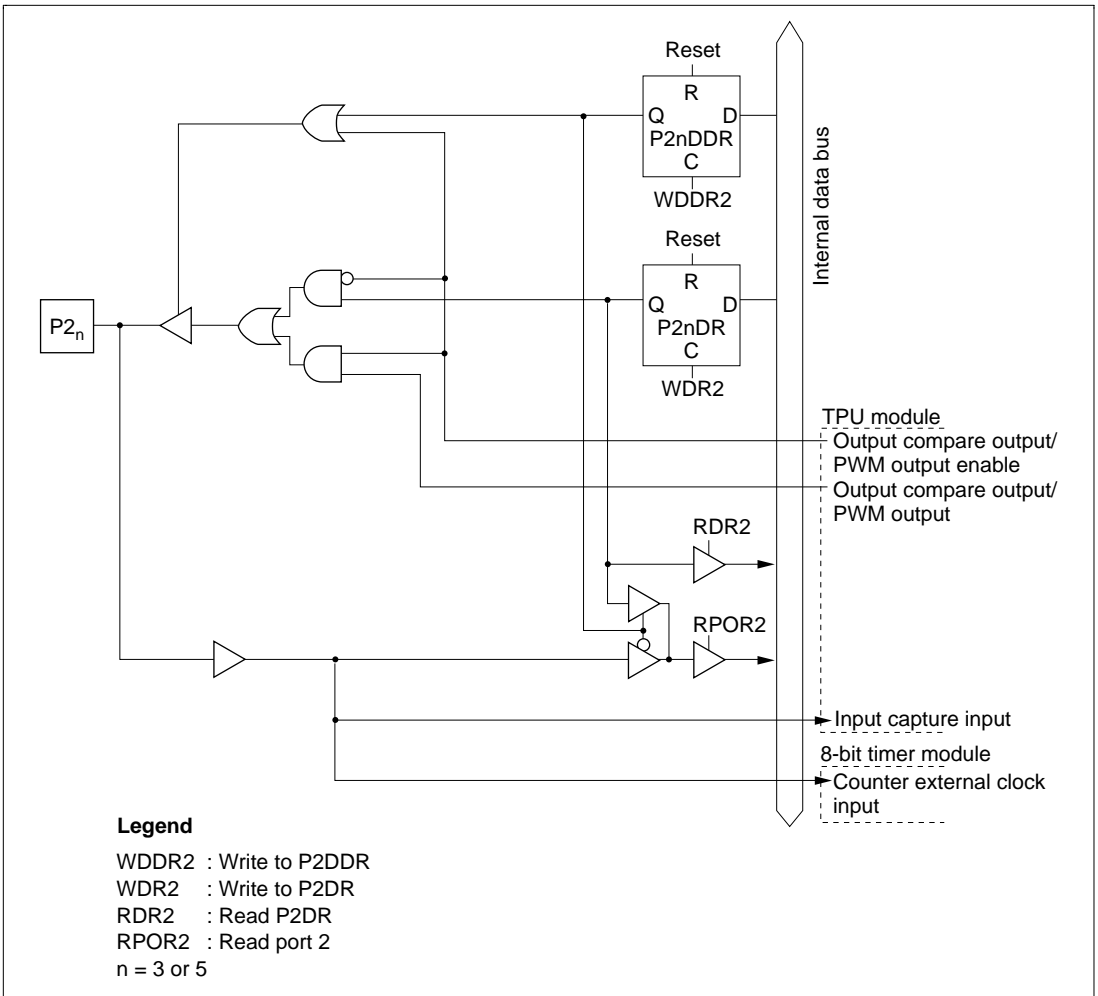

Figure C-2 (c) Port 2 Block Diagram (Pins P2₃ and P2₅)

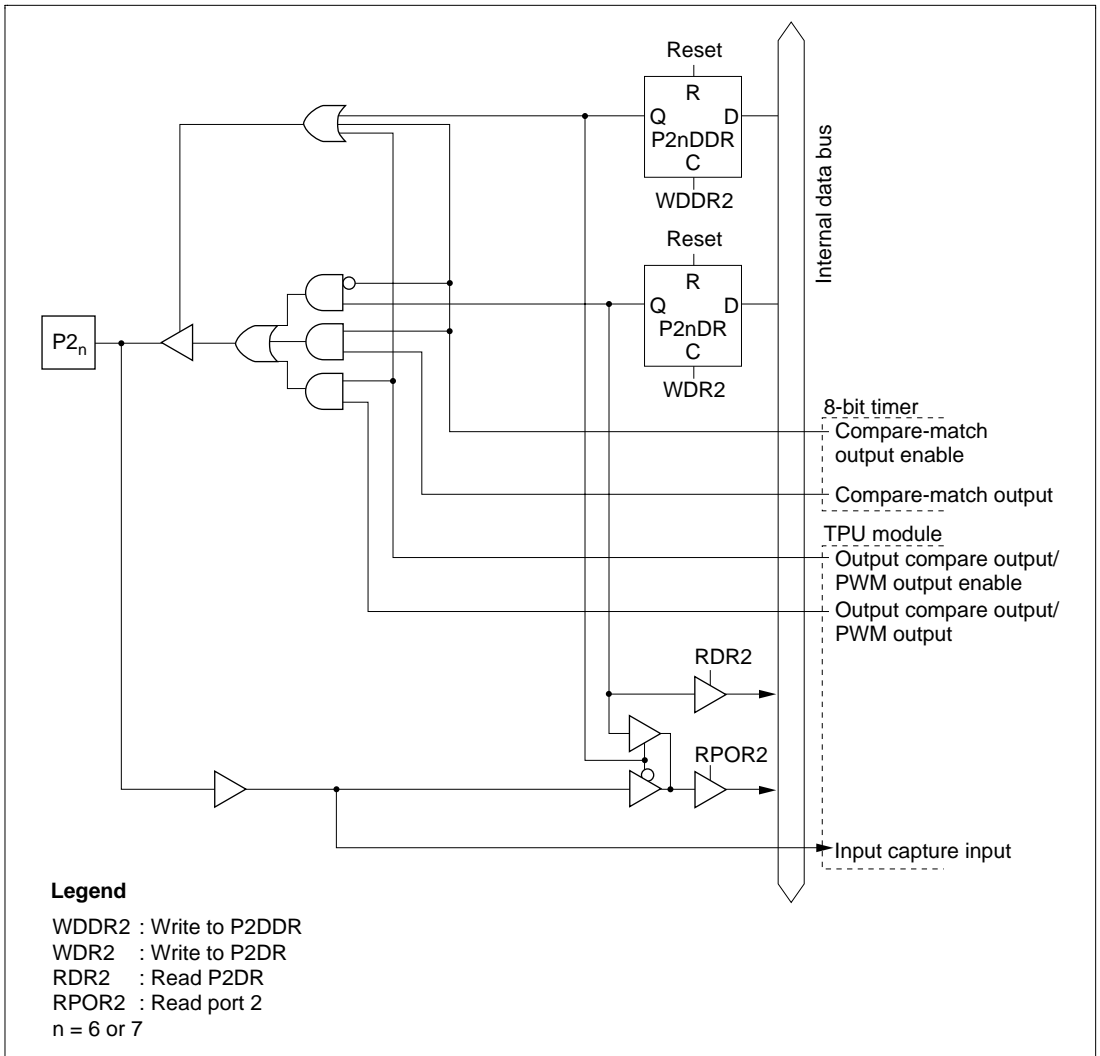

Figure C-2 (d) Port 2 Block Diagram (Pins P2₆ and P2₇)

C.3 Port 3 Block Diagram

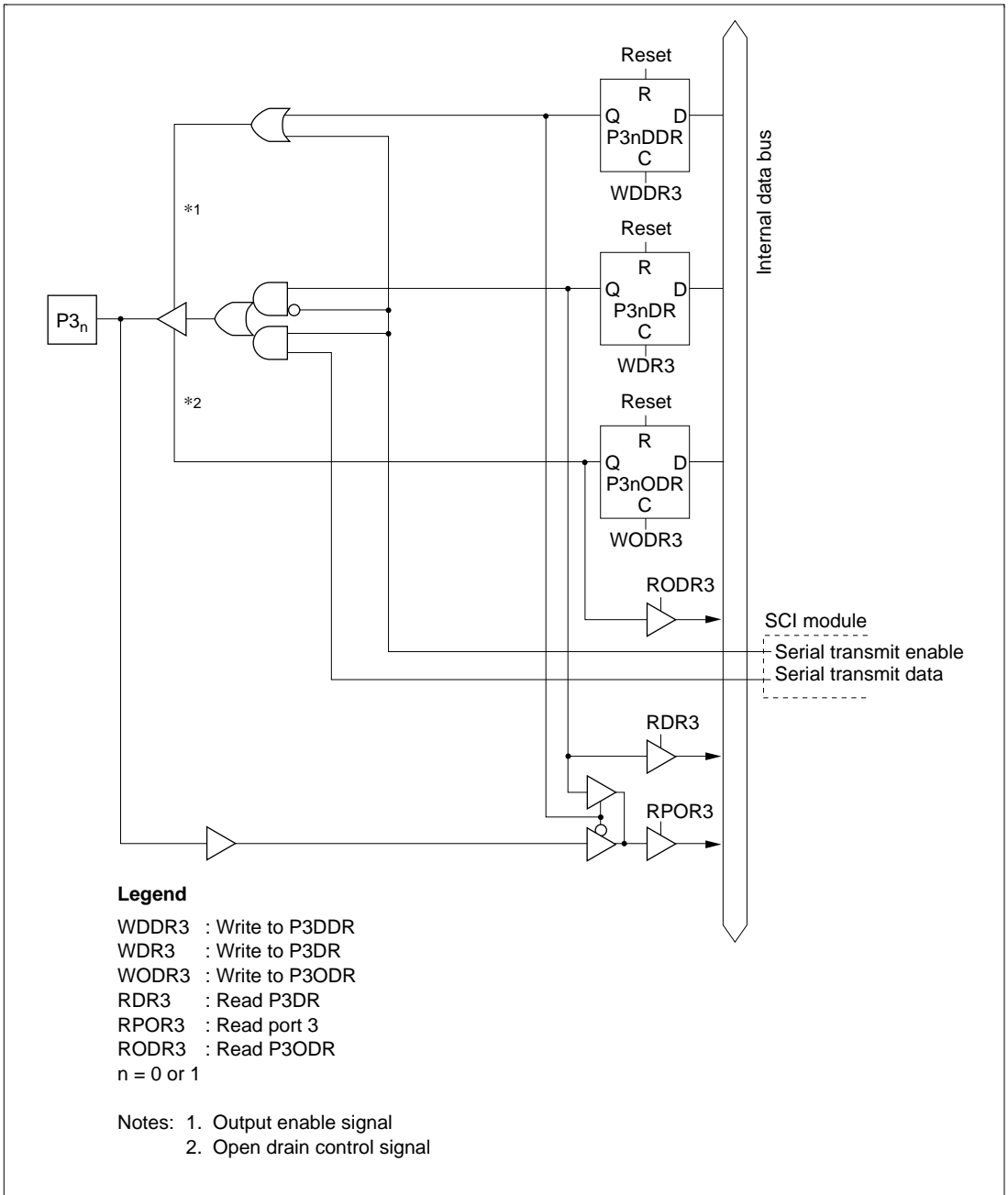
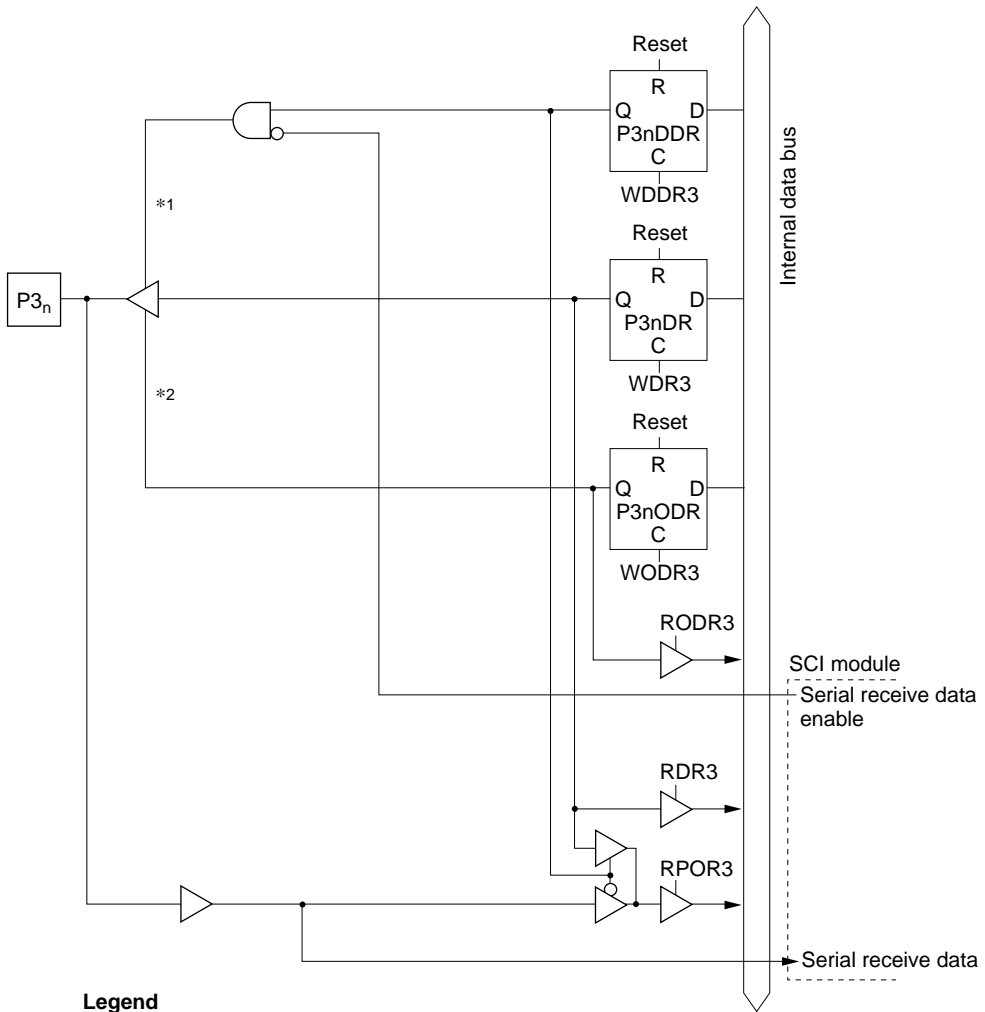

Figure C-3 (a) Port 3 Block Diagram (Pins P3₀ and P3₁)



Legend

- WDDR3 : Write to P3DDR
 - WDR3 : Write to P3DR
 - WODR3 : Write to P3ODR
 - RDR3 : Read P3DR
 - RPOR3 : Read port 3
 - RODR3 : Read P3ODR
- n = 2 or 3

- Notes: 1. Output enable signal
 2. Open drain control signal

Figure C-3 (b) Port 3 Block Diagram (Pins P3₂ and P3₃)

C.4 Port 4 Block Diagram

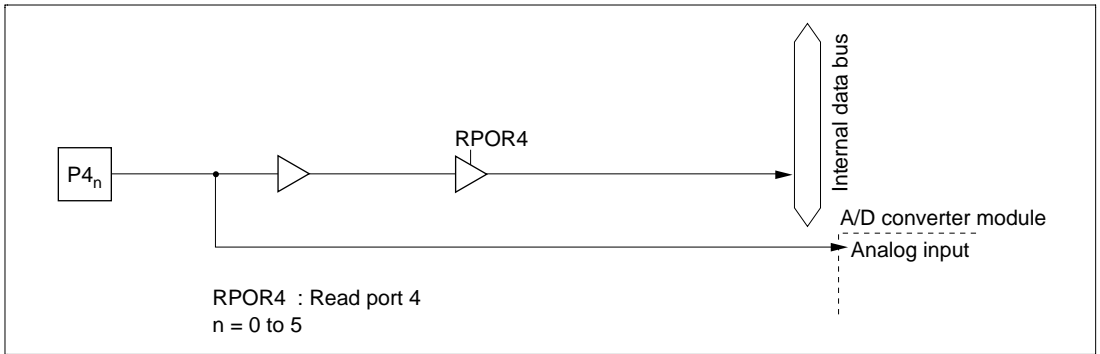

Figure C-4 (a) Port 4 Block Diagram (Pins $P4_0$ to $P4_5$ in H8S/2355 and H8S/2353, Pins $P4_0$ to $P4_7$ in H8S/2393)

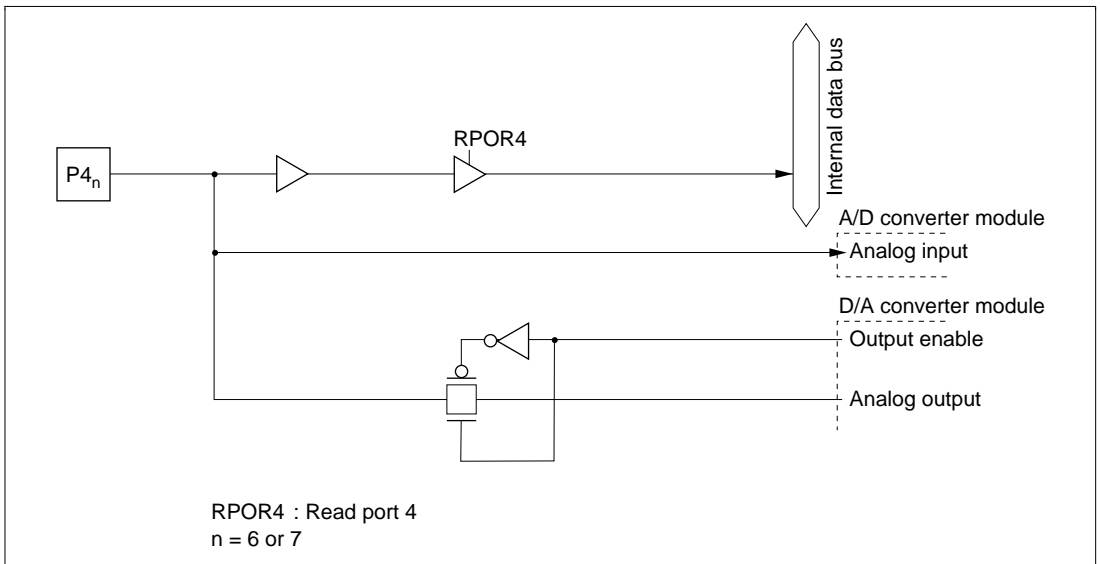

Figure C-4 (b) Port 4 Block Diagram (Pins $P4_6$ and $P4_7$ in H8S/2355 and H8S/2353)

C.5 Port 5 Block Diagram

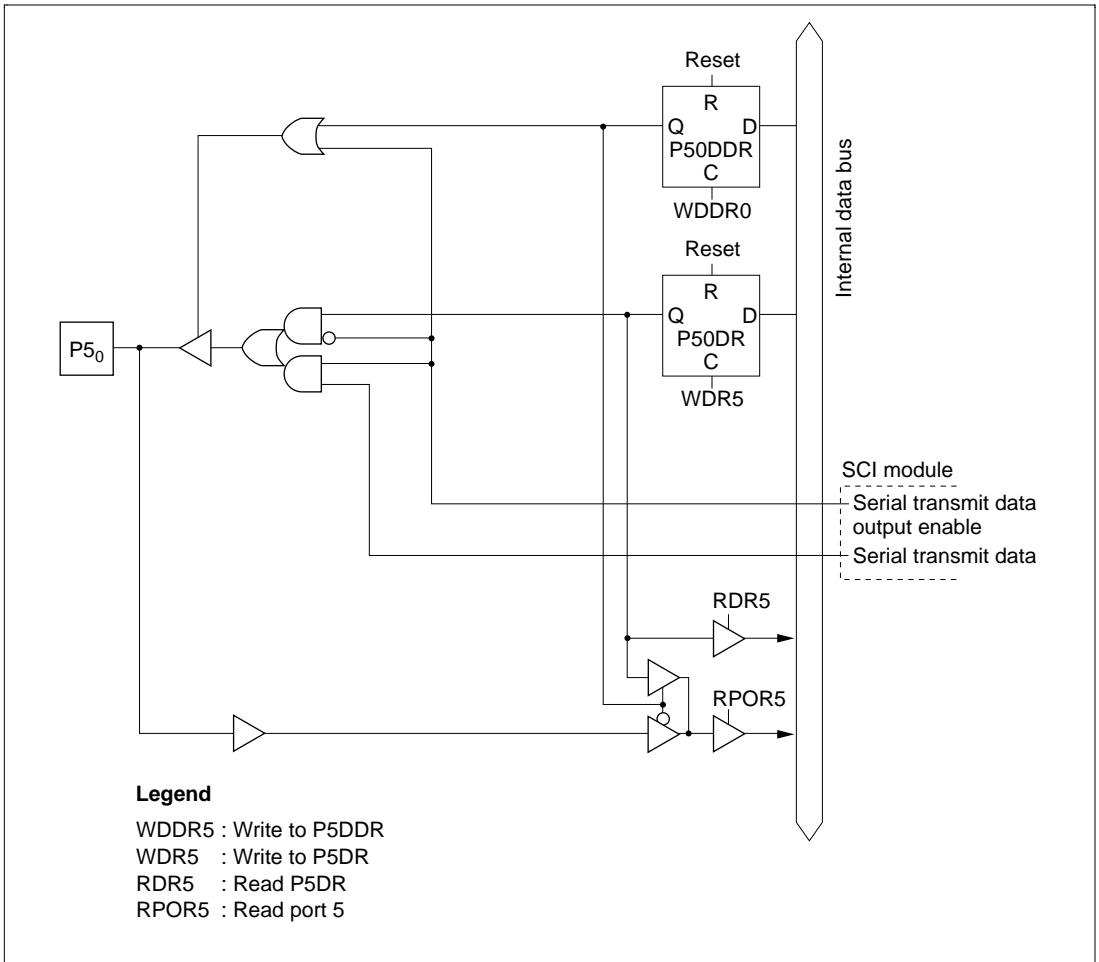

Figure C-5 (a) Port 5 Block Diagram (Pin P5₀)

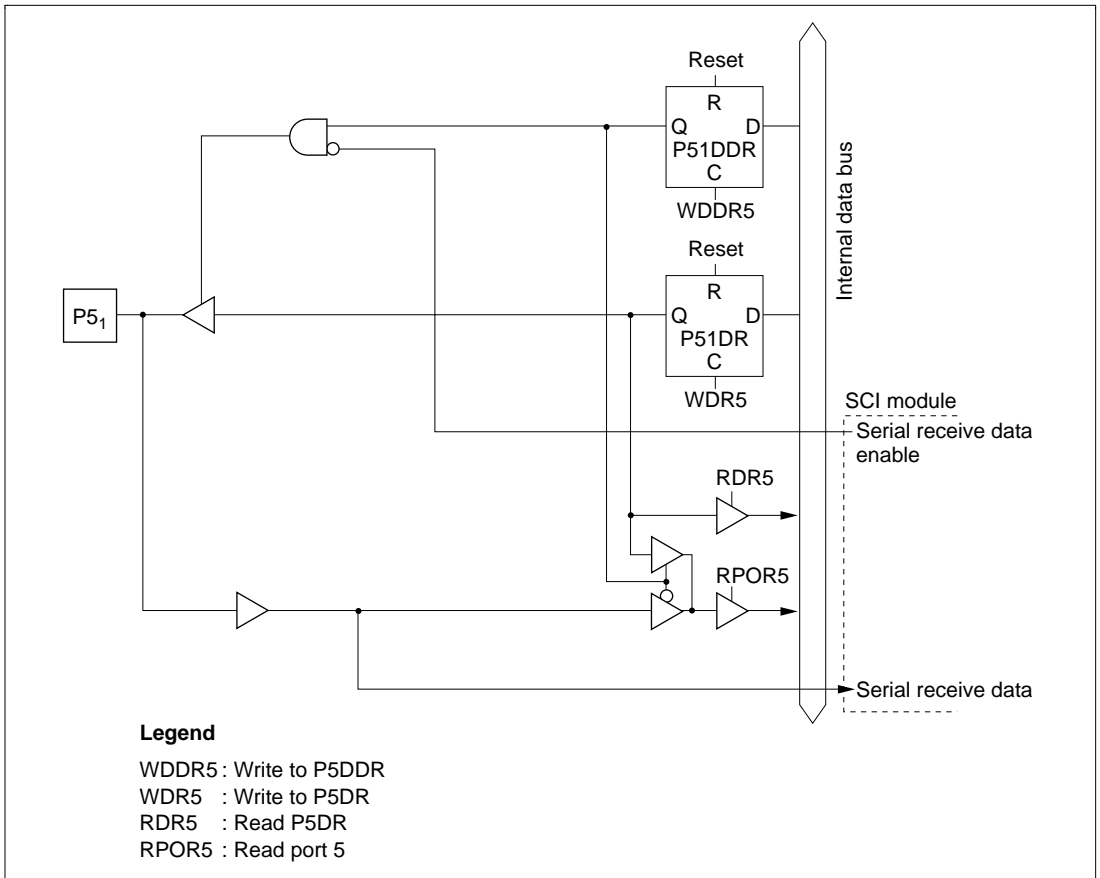

Figure C-5 (b) Port 5 Block Diagram (Pin P5₁)

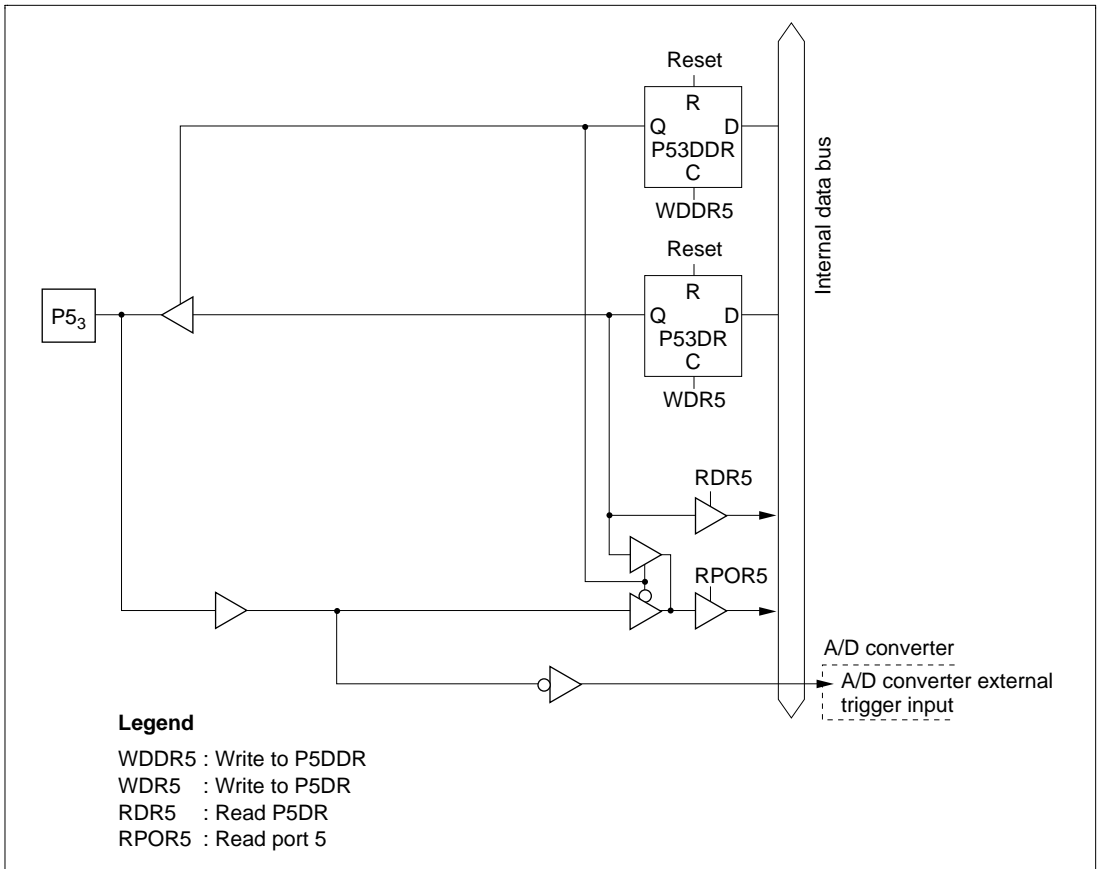
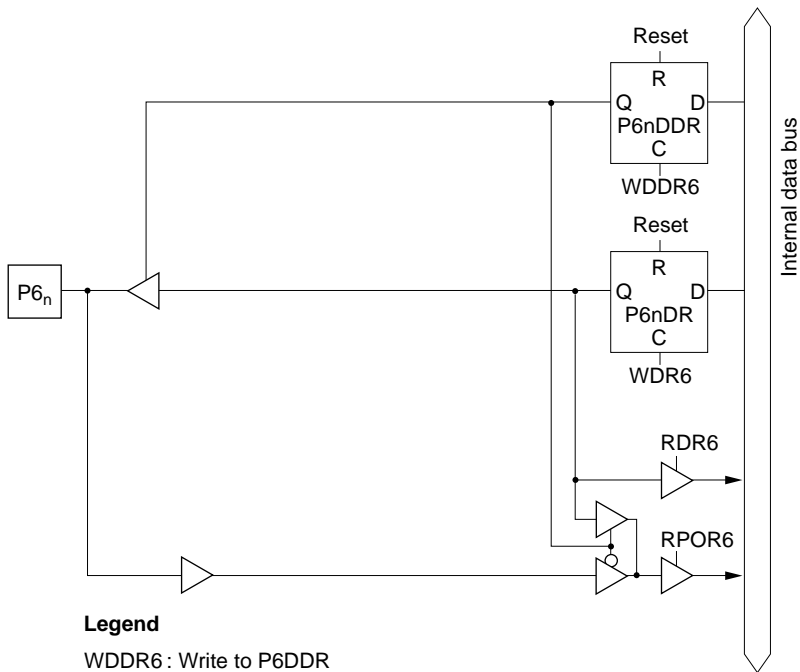

Figure C-5 (d) Port 5 Block Diagram (Pin P5₃)



Legend

- WDDR6 : Write to P6DDR
- WDR6 : Write to P6DR
- RDR6 : Read P6DR
- RPOR6 : Read port 6
- $n = 2 \text{ or } 3$

Figure C-6 (b) Port 6 Block Diagram (Pins P6₂ and P6₃)

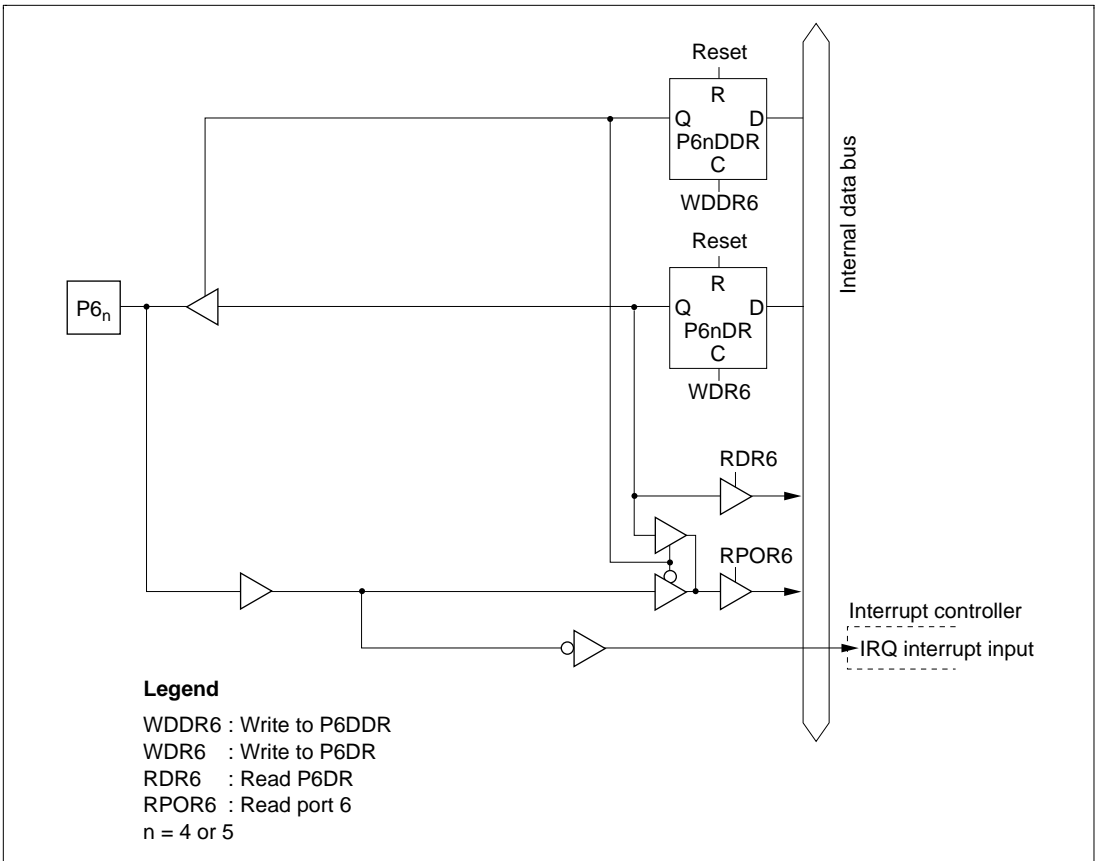

Figure C-6 (c) Port 6 Block Diagram (Pins P6₄ and P6₅)

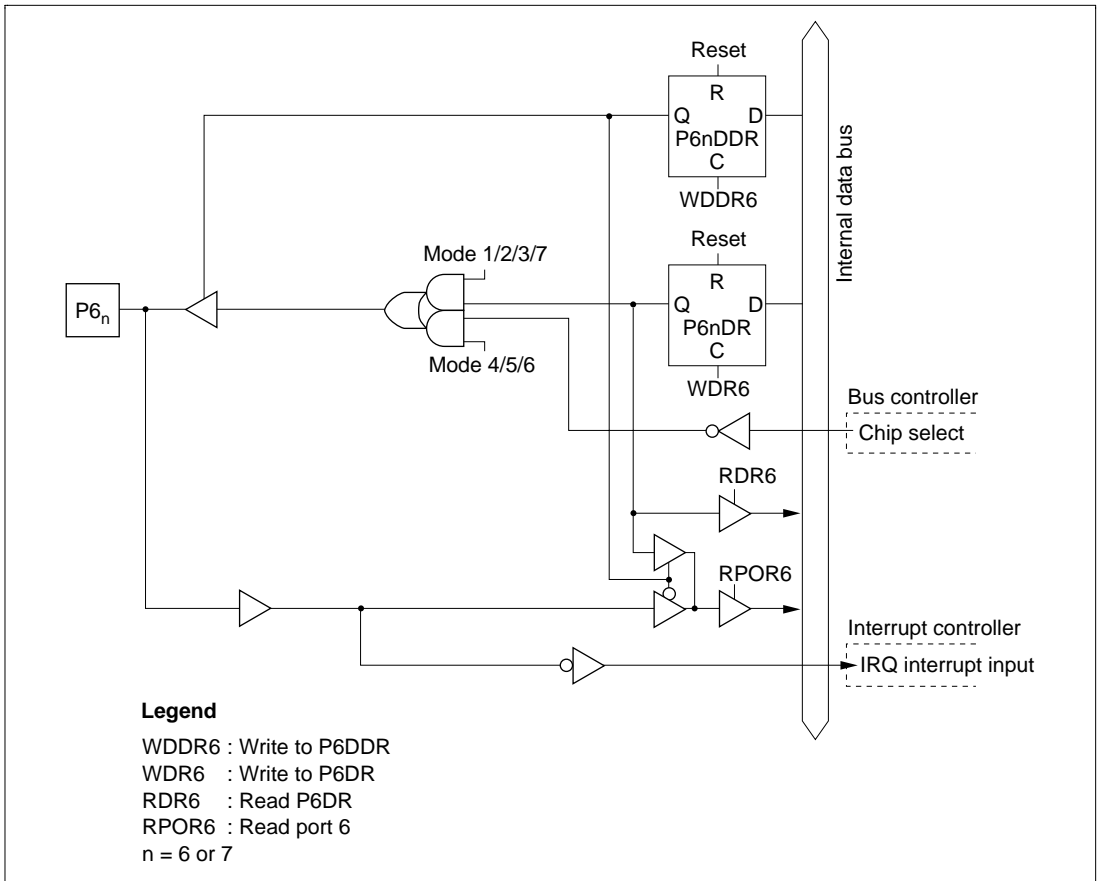

Figure C-6 (d) Port 6 Block Diagram (Pins P6₆ and P6₇)

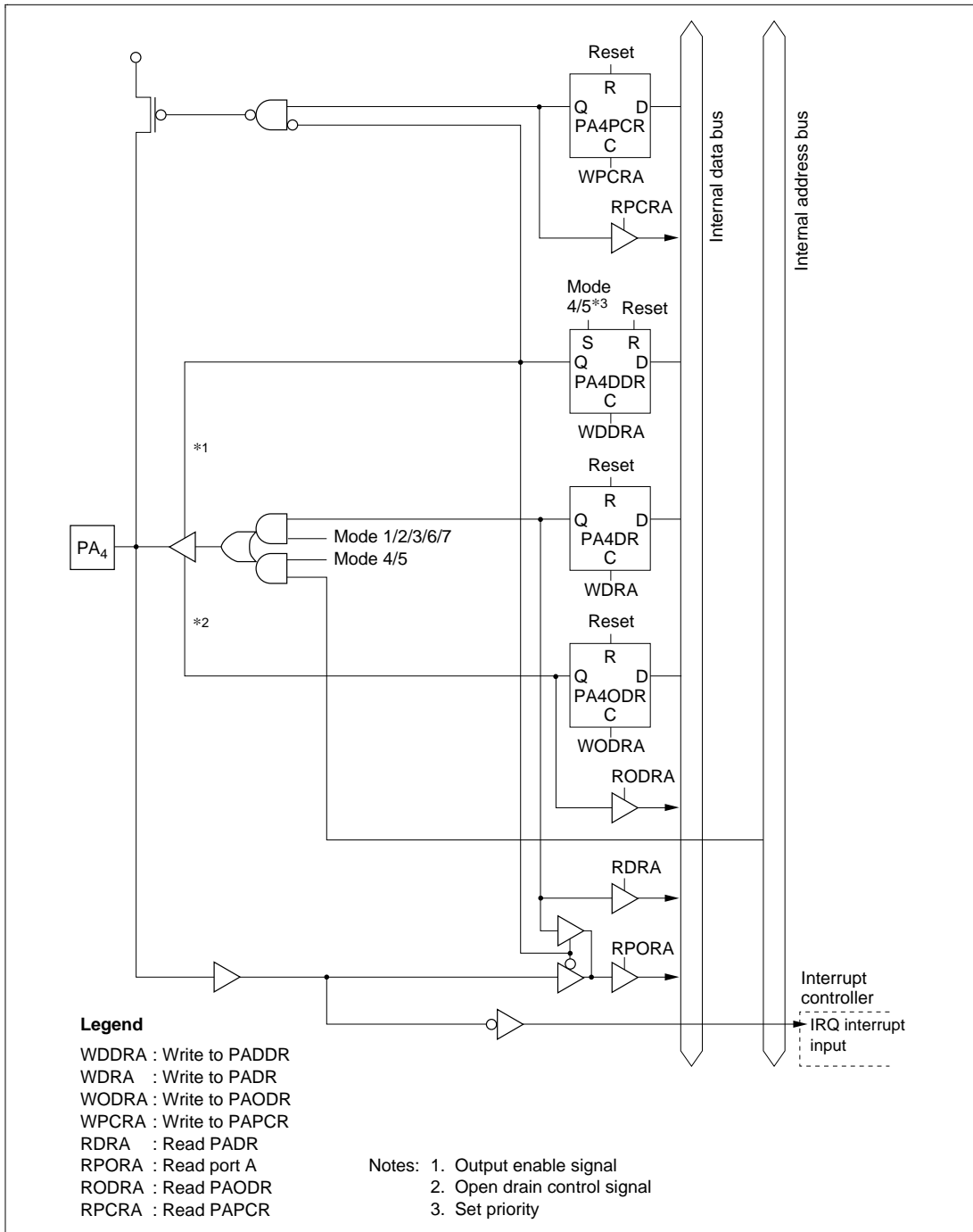

Figure C-7 (b) Port A Block Diagram (Pin PA₄)

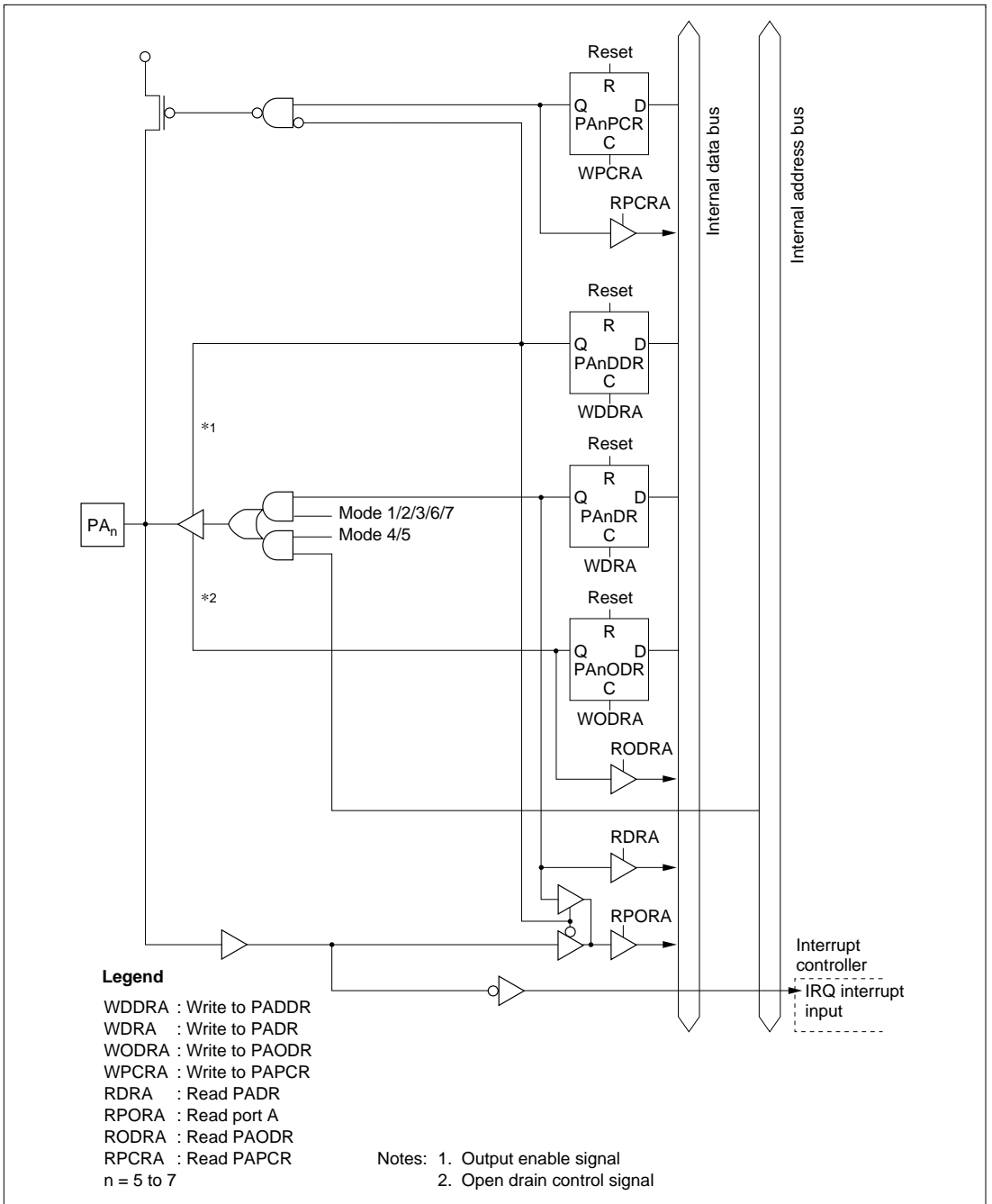

Figure C-7 (c) Port A Block Diagram (Pins PA₅ to PA₇)

C.12 Port F Block Diagram

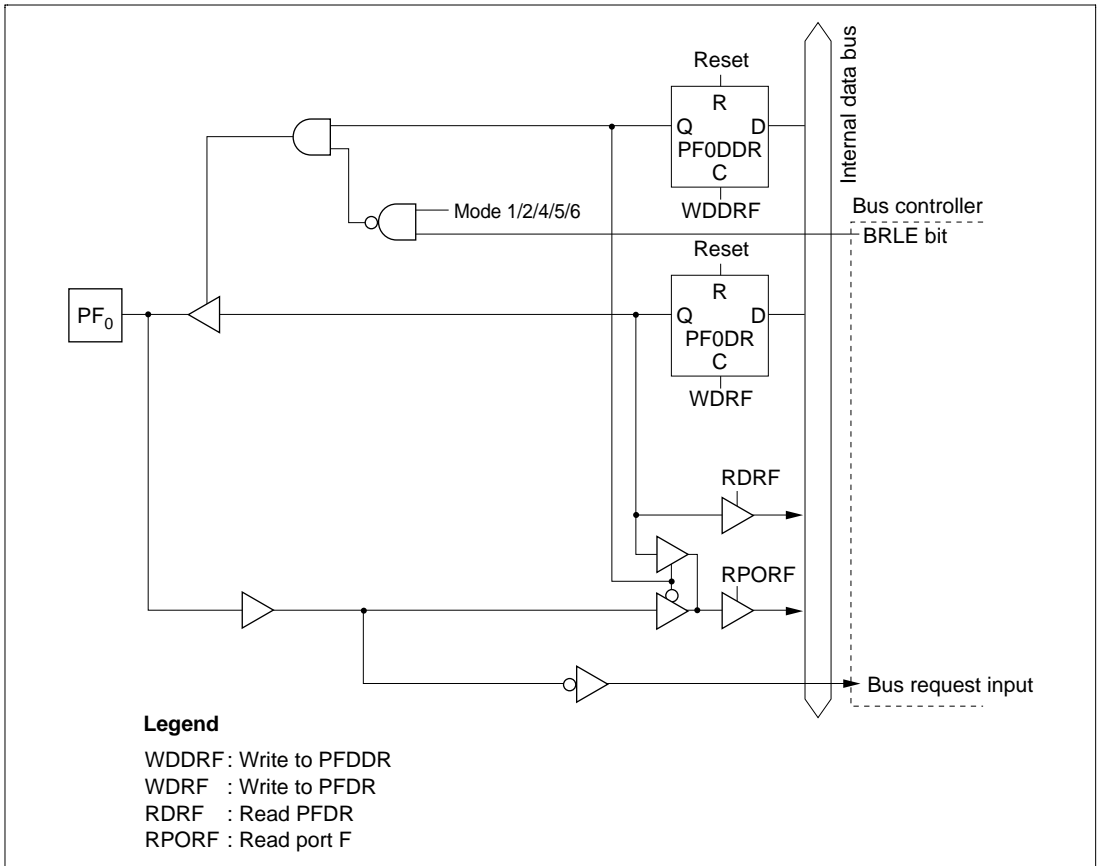

Figure C-12 (a) Port F Block Diagram (Pin PF₀)

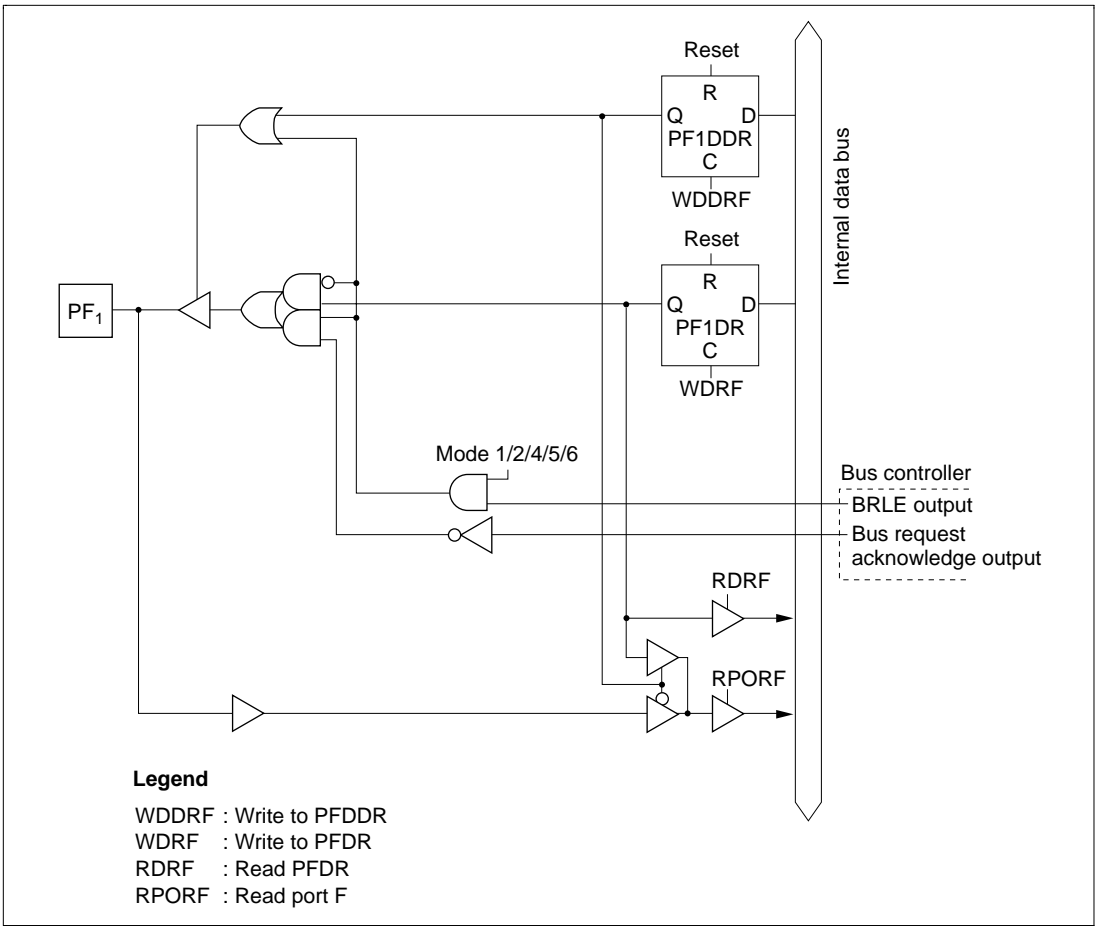

Figure C-12 (b) Port F Block Diagram (Pin PF₁)

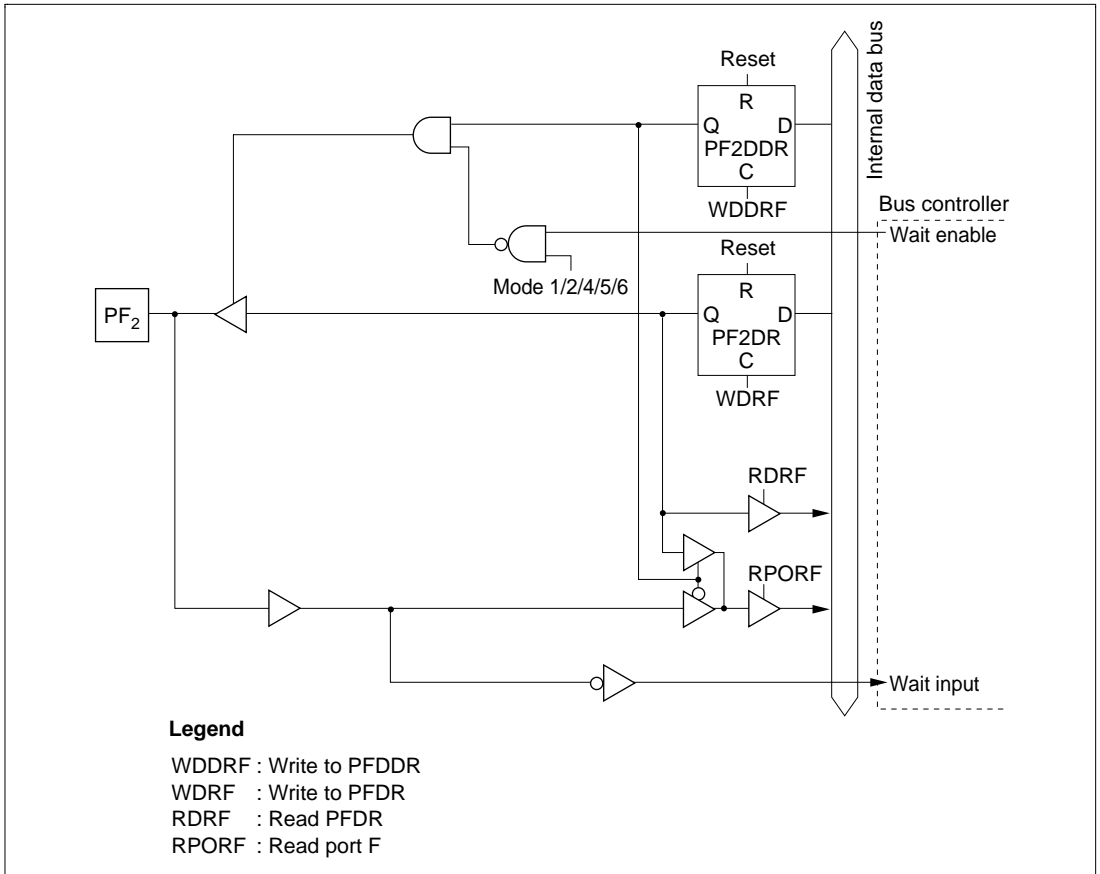

Figure C-12 (c) Port F Block Diagram (Pin PF₂)

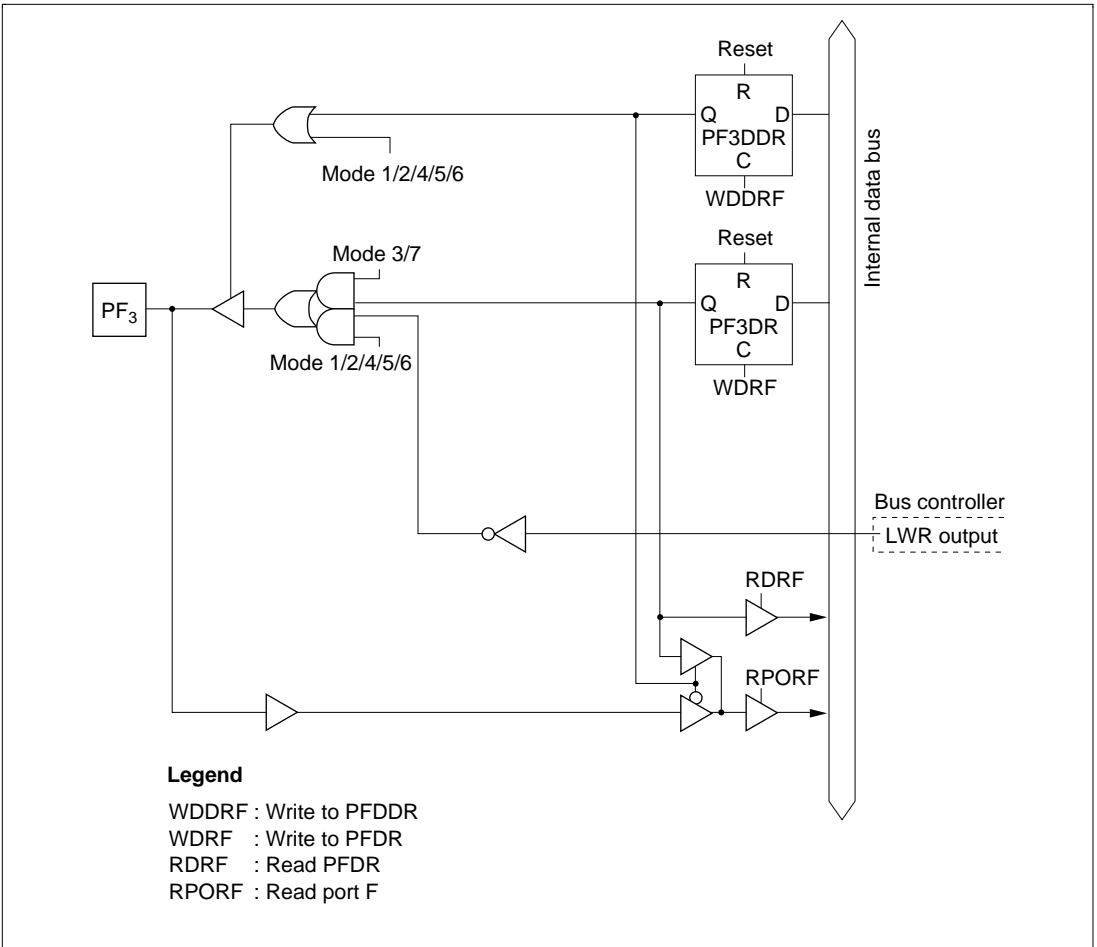

Figure C-12 (d) Port F Block Diagram (Pin PF₃)

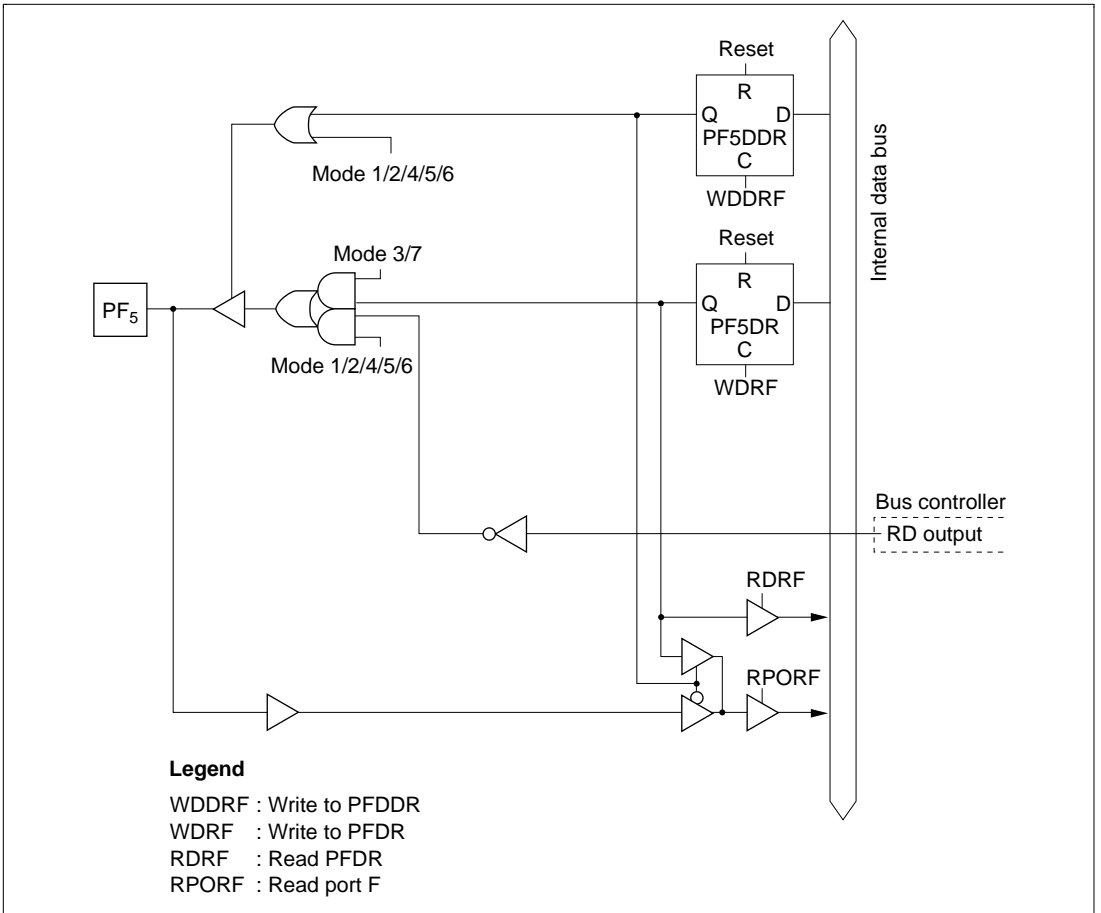

Figure C-12 (f) Port F Block Diagram (Pin PF₅)

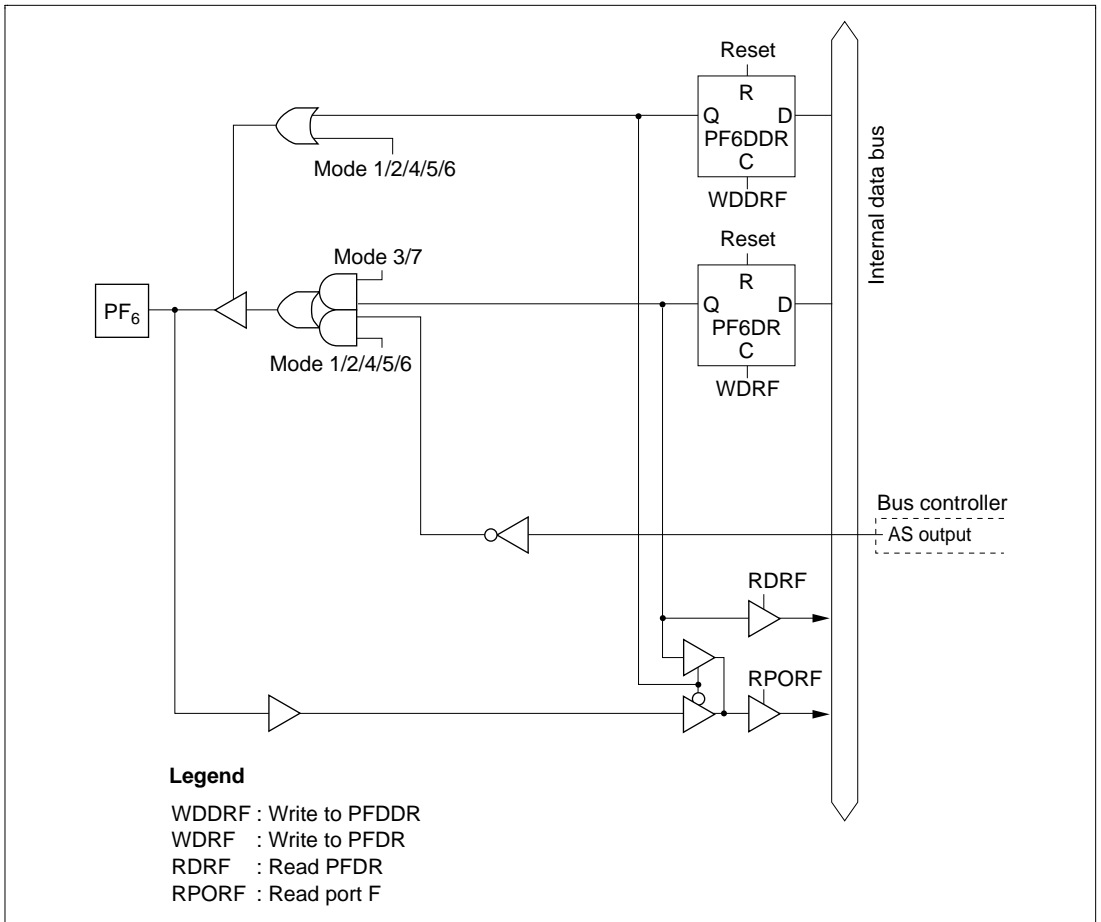

Figure C-12 (g) Port F Block Diagram (Pin PF₆)

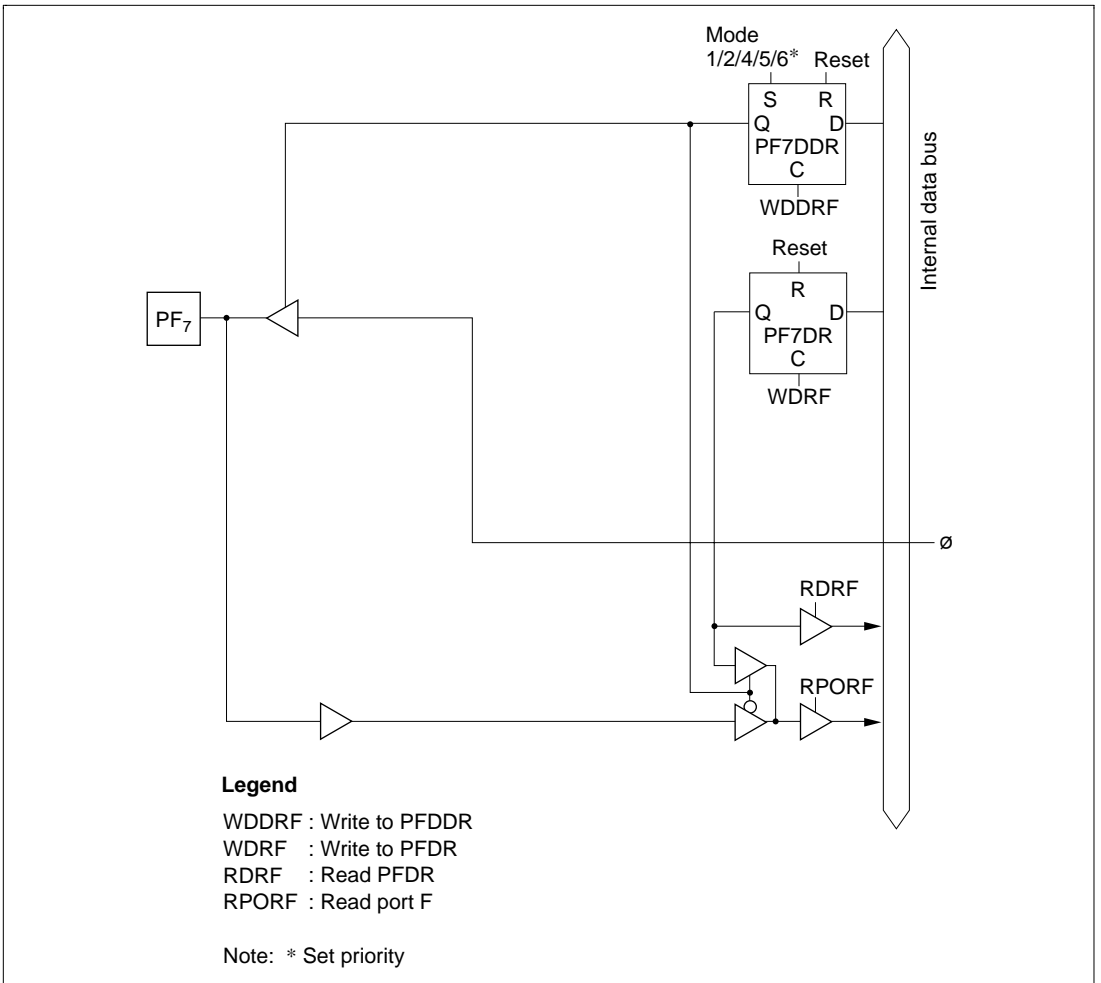

Figure C-12 (h) Port F Block Diagram (Pin PF₇)

C.13 Port G Block Diagram

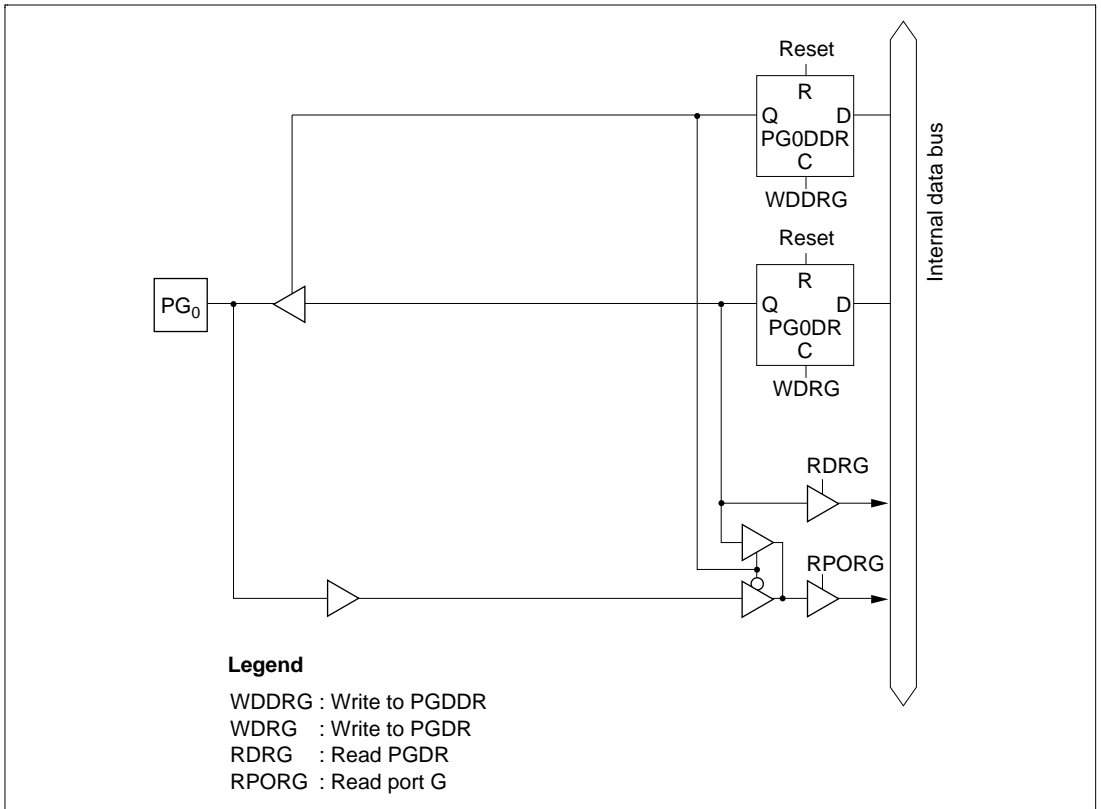

Figure C-13 (a) Port G Block Diagram (Pin PG₀)

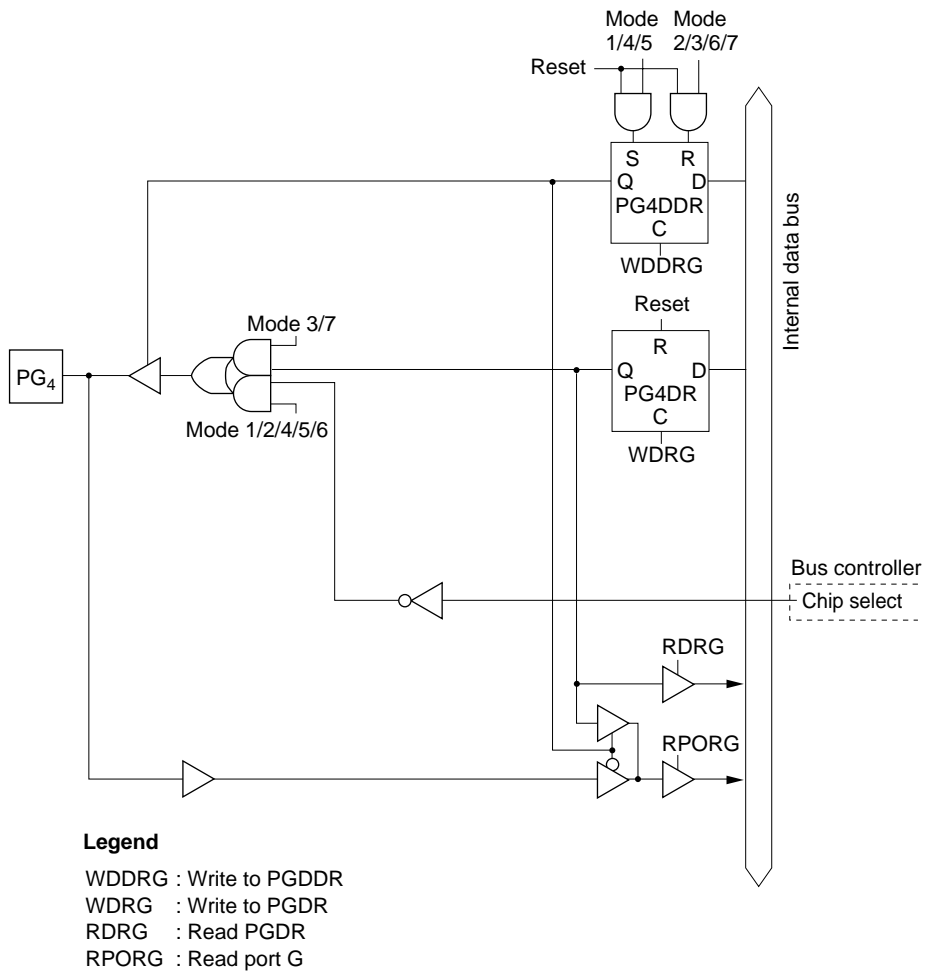

Figure C-13 (c) Port G Block Diagram (Pin PG₄)

Appendix D Pin States

D.1 Port States in Each Mode

Table D-1 I/O Port States in Each Processing State

Port Name Pin Name	MCU Operating Mode	Power- On Reset	Manual Reset	Hardware Standby Mode	Software Standby Mode	Bus Release State	Program Execution State Sleep Mode
Port 1	1 to 7	T	kept	T	kept	kept	I/O port
Port 2	1 to 7	T	kept	T	kept	kept	I/O port
Port 3	1 to 7	T	kept	T	kept	kept	I/O port
P4 ₇ /DA1	1 to 7	T	T	T	[DAOE1 = 1] kept [DAOE1 = 0] T	kept	I/O port
P4 ₆ /DA0	1 to 7	T	T	T	[DAOE0 = 1] kept [DAOE0 = 0] T	kept	I/O port
P4 ₅ to P4 ₀	1 to 7	T	T	T	T	T	Input port
Port 5	1 to 7	T	kept	T	kept	kept	I/O port
P6 ₅ to P6 ₂	1 to 7	T	kept	T	kept	kept	I/O port
P6 ₇ / $\overline{CS7}$	1 to 3, 7	T	kept	T	kept	kept	I/O port
P6 ₆ / $\overline{CS6}$ P6 ₁ / $\overline{CS5}$ P6 ₀ / $\overline{CS4}$	4 to 6	T	kept	T	[DDR · OPE = 0] T [DDR · OPE = 1] H	T	[DDR = 0] Input port [DDR = 1] $\overline{CS7}$ to $\overline{CS4}$
Port A	1 to 3, 7	T	kept	T	kept	kept	I/O port
	4, 5	L	kept	T	[OPE = 0] T [OPE = 1] kept	T	Address output
	6	T	kept	T	[DDR · OPE = 0] T [DDR · OPE = 1] kept	T	[DDR = 0] Input port [DDR = 1] Address output

Port Name Pin Name	MCU Operating Mode	Power- On Reset	Manual Reset	Hardware Standby Mode	Software Standby Mode	Bus Release State	Program Execution State Sleep Mode	
Port B	1, 4, 5	L	kept	T	[OPE = 0] T [OPE = 1] kept	T	Address output	
	2, 6	T	kept	T	[DDR · OPE = 0] T [DDR · OPE = 1] kept	T	[DDR = 0] Input port [DDR = 1] Address output	
	3, 7	T	kept	T	kept	kept	I/O port	
Port C	1, 4, 5	L	kept	T	[OPE = 0] T [OPE = 1] kept	T	Address output	
	2, 6	T	kept	T	[DDR · OPE = 0] T [DDR · OPE = 1] kept	T	[DDR = 0] Input port [DDR = 1] Address output	
	3, 7	T	kept	T	kept	kept	I/O port	
Port D	1, 2, 4 to 6	T	T*	T	T	T	Data bus	
	3, 7	T	kept	T	kept	kept	I/O port	
Port E	1, 2, 4 to 6	8 bit bus	T	kept	T	kept	kept	I/O port
		16 bit bus	T	T*	T	T	T	Data bus
	3, 7	T	kept	T	kept	kept	kept	I/O port
PF ₇ /ø	1, 2, 4 to 6	Clock output	[DDR = 0] T [DDR = 1] Clock output	T	[DDR = 0] Input port [DDR = 1] H	[DDR = 0] Input port [DDR = 1] Clock output	[DDR = 0] Input port [DDR = 1] Clock output	
	3, 7	T	kept	T	[DDR = 0] Input port [DDR = 1] H	[DDR = 0] Input port [DDR = 1] Clock output	[DDR = 0] Input port [DDR = 1] Clock output	

Port Name Pin Name	MCU Operating Mode	Power- On Reset	Manual Reset	Hardware Standby Mode	Software Standby Mode	Bus Release State	Program Execution State Sleep Mode
PF ₆ / $\overline{\text{AS}}$ PF ₅ / $\overline{\text{RD}}$ PF ₄ / $\overline{\text{HWR}}$ PF ₃ / $\overline{\text{LWR}}$	1, 2, 4 to 6	H	H*	T	[OPE = 0] T [OPE = 1] H	T	$\overline{\text{AS}}$, $\overline{\text{RD}}$, $\overline{\text{HWR}}$, $\overline{\text{LWR}}$
	3, 7	T	kept	T	kept	kept	I/O port
PF ₂ / $\overline{\text{WAIT}}$	1, 2, 4 to 6	T	[WAITE = 0] kept [WAITE = 1] T	T	[WAITE = 0] kept [WAITE = 1] T	[WAITE = 0] kept [WAITE = 1] T	[WAITE = 0] I/O port [WAITE = 1] $\overline{\text{WAIT}}$
	3, 7	T	kept	T	kept	kept	I/O port
PF ₁ / $\overline{\text{BACK}}$	1, 2, 4 to 6	T	[BRLE = 0] kept [BRLE = 1] $\overline{\text{BACK}}$	T	[BRLE = 0] kept [BRLE = 1] H	L	[BRLE = 0] I/O port [BRLE = 1] $\overline{\text{BACK}}$
	3, 7	T	kept	T	kept	kept	I/O port
PF ₀ / $\overline{\text{BREQ}}$	1, 2, 4 to 6	T	[BRLE = 0] kept [BRLE = 1] $\overline{\text{BREQ}}$	T	[BRLE = 0] kept [BRLE = 1] T	T	[BRLE = 0] I/O port [BRLE = 1] $\overline{\text{BREQ}}$
	3, 7	T	kept	T	kept	kept	I/O port
PG ₄ / $\overline{\text{CS0}}$	1, 4, 5 2, 6	H T	[DDR = 0] T [DDR = 1] H*	T	[DDR · OPE = 0] T [DDR · OPE = 1] H	T	[DDR = 0] Input port [DDR = 1] $\overline{\text{CS}}_0$
	3, 7	T	kept	T	kept	kept	I/O port
PG ₃ / $\overline{\text{CS1}}$ PG ₂ / $\overline{\text{CS2}}$ PG ₁ / $\overline{\text{CS3}}$	1 to 3, 7 4 to 6	T T	kept [DDR = 0] T [DDR = 1] H*	T	kept [DDR · OPE = 0] T [DDR · OPE = 1] H	kept T	I/O port [DDR = 0] Input port [DDR = 1] $\overline{\text{CS}}_1$ to $\overline{\text{CS}}_3$

Port Name Pin Name	MCU Operating Mode	Power- On Reset	Manual Reset	Hardware Standby Mode	Software Standby Mode	Bus Release State	Program Execution State Sleep Mode
\overline{PG}_0	1 to 3, 7	T	kept	T	kept	kept	I/O port
	4 to 6	T	kept	T	kept	T	I/O port

Legend:

- H : High level
- L : Low level
- T : High impedance
- kept : Input port becomes high-impedance, output port retains state
- DDR : Data direction register
- OPE : Output port enable
- WAITE : Wait input enable
- BRLE : Bus release enable
- DRAME : DRAM space setting

Note: * Indicates the state after completion of the executing bus cycle.

Appendix E Pin States at Power-On

Note that pin states at power-on depend on the state of the $\overline{\text{STBY}}$ pin and NMI pin. The case in which pins settle* from an indeterminate state at power-on, and the case in which pins settle* from the high-impedance state, are described below.

After reset release, power-on reset exception handling is started.

Note: * “Settle” refers to the pin states in a power-on reset in each MCU operating mode.

E.1 When Pins Settle from an Indeterminate State at Power-On

When the NMI pin level changes from low to high after powering on, the chip goes to the power-on reset state after a high level is detected at the NMI pin. While the chip detects a low level at the NMI pin, the manual reset state is established. The pin states are indeterminate during this interval. (Ports may output an internally determined value after powering on.)

The NMI setup time (t_{NMIS}) is necessary for the chip to detect a high level at the NMI pin.

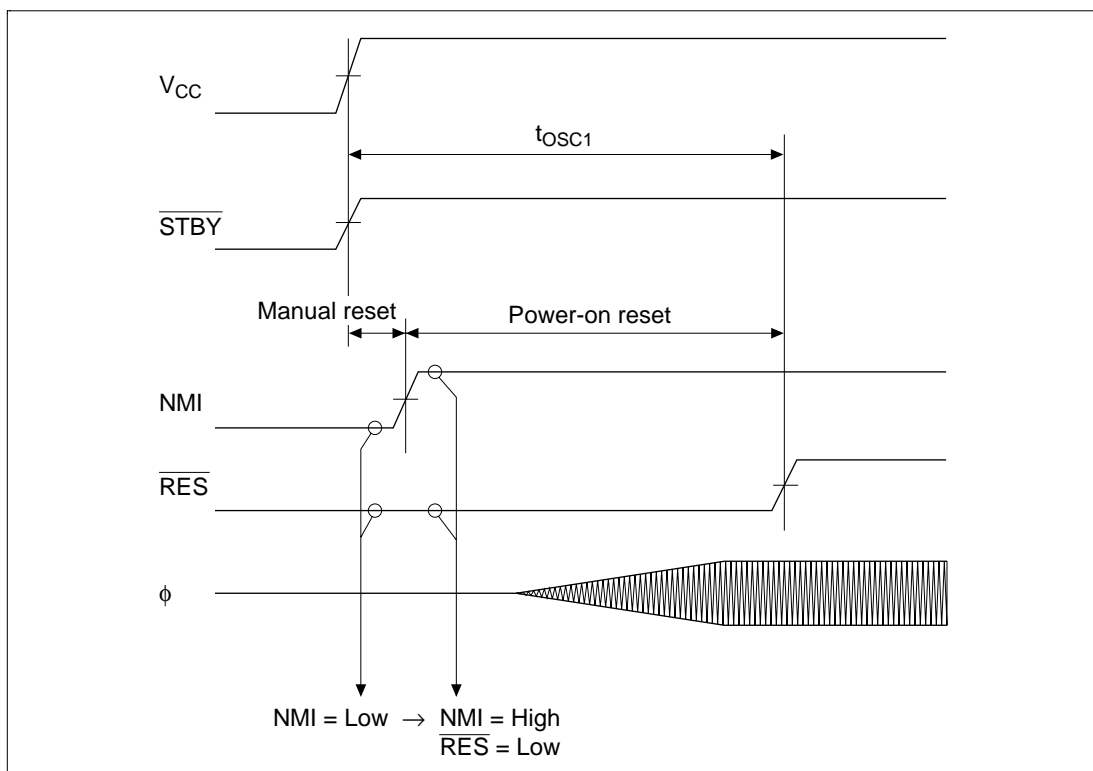

Figure E-1 When Pins Settle from an Indeterminate State at Power-On

E.2 When Pins Settle from the High-Impedance State at Power-On

When the $\overline{\text{STBY}}$ pin level changes from low to high after powering on, the chip goes to the power-on reset state after a high level is detected at the $\overline{\text{STBY}}$ pin. While the chip detects a low level at the $\overline{\text{STBY}}$ pin, it is in the hardware standby mode. During this interval, the pins are in the high-impedance state.

After detecting a high level at the $\overline{\text{STBY}}$ pin, the chip starts oscillation.

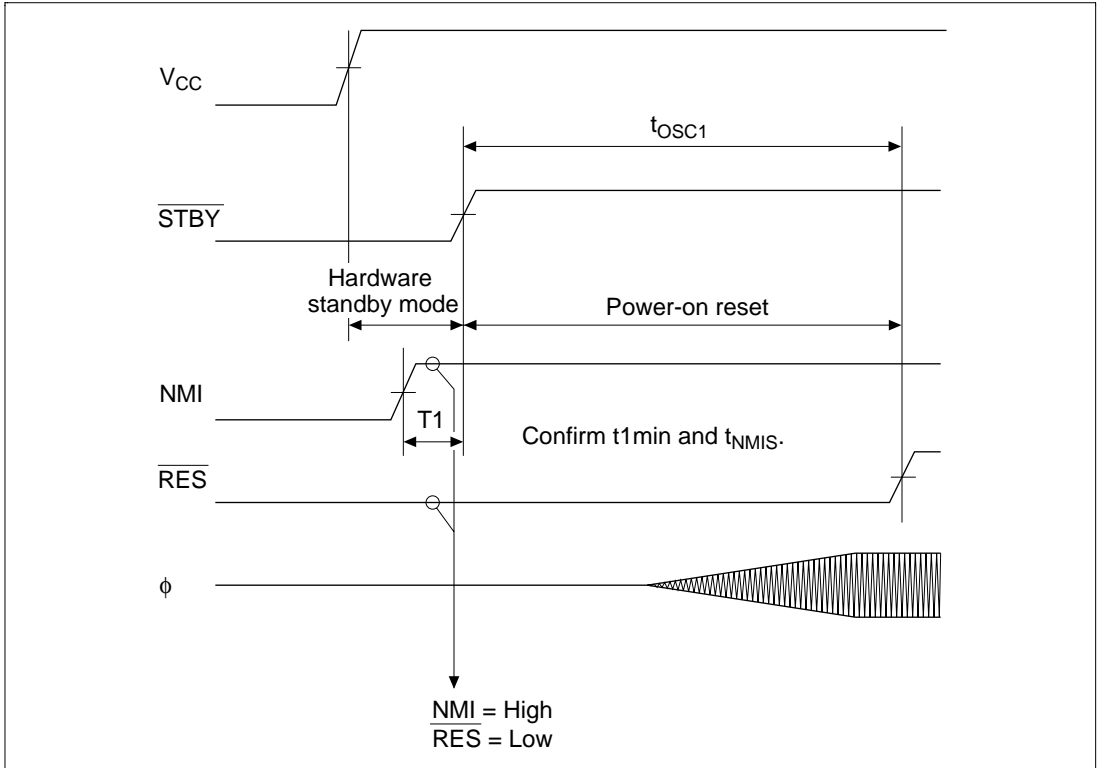

Figure E-2 When Pins Settle from the High-Impedance State at Power-On

Appendix F Timing of Transition to and Recovery from Hardware Standby Mode

Timing of Transition to Hardware Standby Mode

- (1) To retain RAM contents with the RAME bit set to 1 in SYSCR, drive the $\overline{\text{RES}}$ signal low at least 10 states before the $\overline{\text{STBY}}$ signal goes low, as shown below. $\overline{\text{RES}}$ must remain low until $\overline{\text{STBY}}$ signal goes low (delay from $\overline{\text{STBY}}$ low to $\overline{\text{RES}}$ high: 0 ns or more).

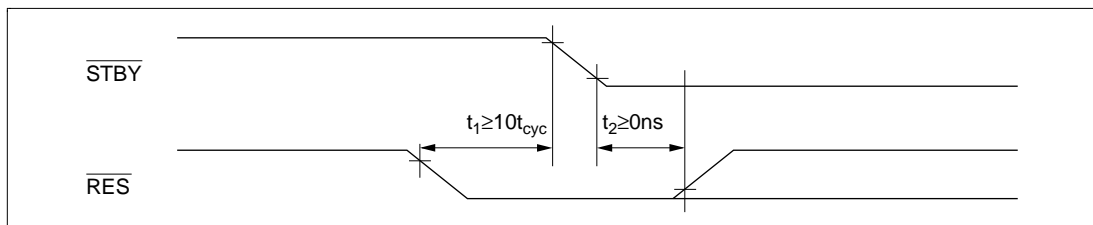

Figure F-1 Timing of Transition to Hardware Standby Mode

- (2) To retain RAM contents with the RAME bit cleared to 0 in SYSCR, or when RAM contents do not need to be retained, $\overline{\text{RES}}$ does not have to be driven low as in (1).

Timing of Recovery from Hardware Standby Mode

Drive the $\overline{\text{RES}}$ signal low and the NMI signal high approximately 100 ns or more before $\overline{\text{STBY}}$ goes high to execute a power-on reset.

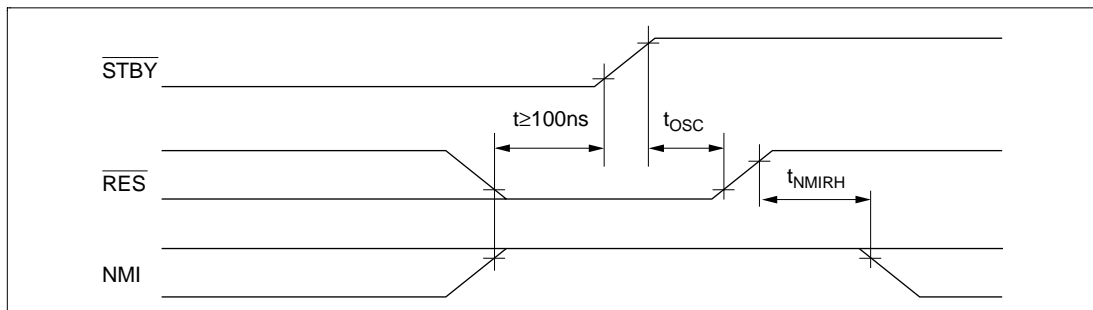

Figure F-2 Timing of Recovery from Hardware Standby Mode

Appendix G Product Code Lineup

Table G.1 H8S/2355 Series Product Code Lineup

Product Type		Product Code	Mark Code	Package (Hitachi Package Code)
H8S/2355	Mask ROM	HD6432355	HD6432355(***)TE	120-pin TFP (TFP-120)
			HD6432355(***)F	128-pin FP (FP-128)
	ZTAT™	HD6472355	HD6472355TE	120-pin TFP (TFP-120)
			HD6472355F	128-pin FP (FP-128)
H8S/2353	Mask ROM	HD6432353	HD6432353(***)TE	120-pin TFP (TFP-120)
			HD6432353(***)F	128-pin FP (FP-128)
H8S/2393	Mask ROM	HD6432393	HD6432393(***)TE	120-pin TFP (TFP-120)
			HD6432393(***)F	120-pin FP (FP-128)

Note: (***) is the ROM code. See table 1.1, Product Lineup, for details.

Appendix H Package Dimensions

Figures H-1 and H-2 show the TFP-120 and FP-128 package dimensions of the H8S/2355 Series.

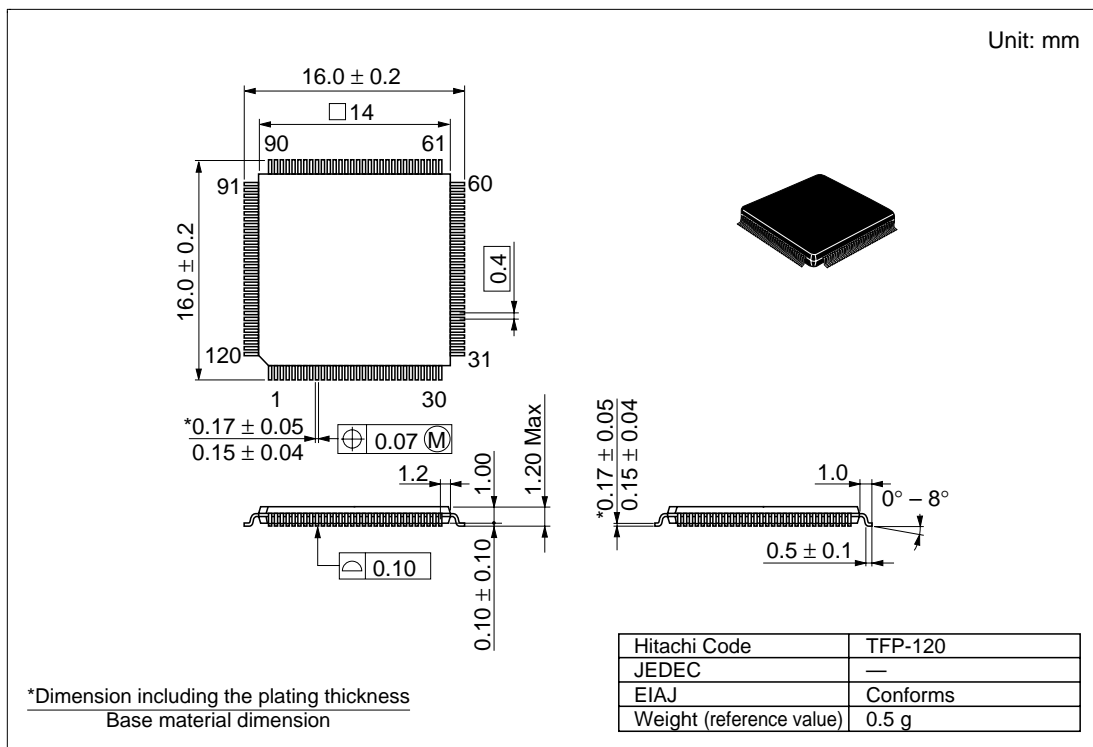
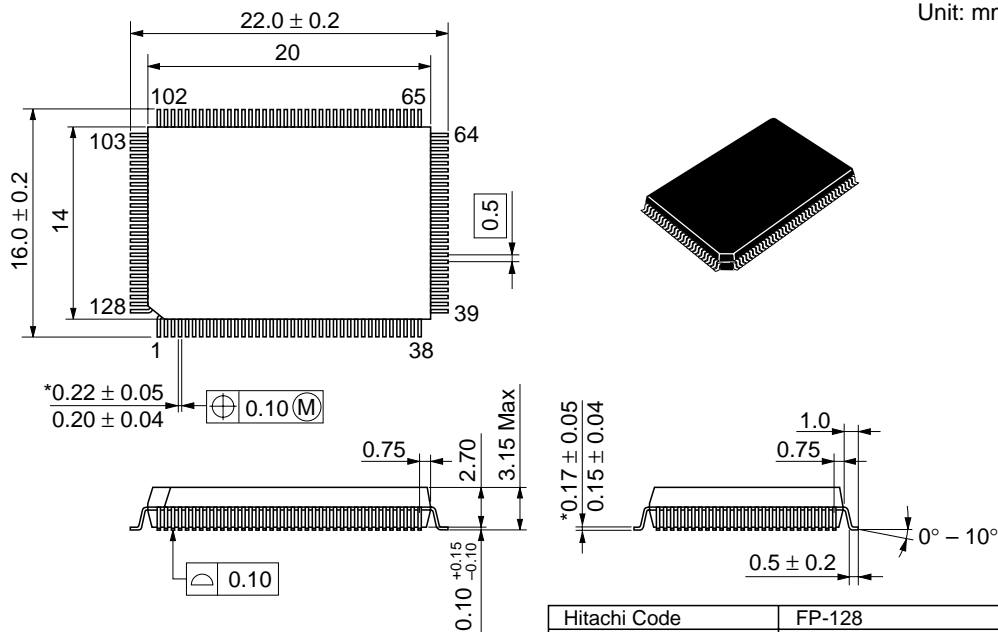

Figure H-1 TFP-120 Package Dimensions

Unit: mm



*Dimension including the plating thickness
Base material dimension

Figure H-2 FP-128 Package Dimensions

H8S/2355 Series Hardware Manual

Publication Date: 1st Edition, April 1997
3rd Edition, February 2000

Published by: Electronic Devices Sales & Marketing Group
Semiconductor & Integrated Circuits

Edited by: Technical Documentation Group
Hitachi Kodaira Semiconductor Co., Ltd.

Copyright © Hitachi, Ltd., 1997. All rights reserved. Printed in Japan.