

MC68EZ328

DragonBall-EZ™

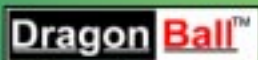

Integrated Processor User's Manual



MOTOROLA

Freescale Semiconductor, Inc.

Order this document by
MC68EZ328UM/D
(Motorola Order Number)
Rev. 1, 11/98

MC68EZ328
Integrated Processor
User's Manual

Motorola, Incorporated
Semiconductor Products Sector
6501 William Cannon Drive West
Austin TX 78735-8598



MOTOROLA

**For More Information On This Product,
Go to: www.freescale.com**

Freescale Semiconductor, Inc.

Freescale Semiconductor, Inc.

Freescale Semiconductor, Inc.

©MOTOROLA INC., 1998. All rights reserved.

This document contains information on a new product. Specifications and information herein are subject to change without notice.

Motorola reserves the right to make changes without further notice to any products herein to improve reliability, function, or design. Motorola does not assume any liability arising out of the application or use of any product or circuit described herein; neither does it convey any license under its patent rights nor the rights of others. Motorola products are not designed, intended, or authorized for use as components in systems intended for surgical implant into the body, or other application in which the failure of the Motorola product could create a situation where personal injury or death may occur. Should Buyer purchase or use Motorola products for any such unintended or unauthorized application, Buyer shall indemnify and hold Motorola and its officers, employees, subsidiaries, affiliates, and distributors harmless against all claims, costs, damages, and expenses, and reasonable attorney fees arising out of, directly or indirectly, any claim of personal injury or death associated with such unintended or unauthorized use, even if such claim alleges that Motorola was negligent regarding the design or manufacture of the part. Motorola and  are registered trademarks of Motorola, Inc. Motorola, Inc. is an Equal Opportunity/Affirmative Action Employer

OnCE and Mfax are trademarks of Motorola, Inc.

**For More Information On This Product,
Go to: www.freescale.com**

TABLE OF CONTENTS

Paragraph Number	Title	Page Number
---------------------	-------	----------------

PREFACE

Related Documentation		xvii
Organization of This Manual		xvii

SECTION 1 BASIC ARCHITECTURE

1.1	Core		1-2
1.1.1	Core Programming Model		1-2
1.1.2	Data and Address Mode Types		1-4
1.1.3	EC000 Instruction Set		1-5
1.2	Chip-Select Logic and Bus Interface		1-6
1.3	Phase-Locked Loop and Power Control		1-6
1.4	Interrupt Controller		1-7
1.5	Parallel General-Purpose I/O Ports		1-7
1.6	Pulse-Width Modulator		1-7
1.7	General-Purpose Timer		1-7
1.8	Serial Peripheral Interface		1-7
1.9	UART and Infra-Red Communication Support		1-8
1.10	LCD Controller		1-8
1.11	Real-Time Clock		1-8
1.12	DRAM Controller		1-8
1.13	In-Circuit Emulation Module		1-8
1.14	Bootstrap Mode		1-8
1.15	Memory Map		1-8

SECTION 2 SIGNAL DESCRIPTIONS

2.1	Signals GROUped by Function		2-3
2.2	POWER and Ground Signals		2-4
2.3	CLOCK and System Control Signals		2-4
2.4	ADDRESS BUS Signals		2-5
2.5	DATA BUS Signals		2-5
2.6	BUS CONTROL Signals		2-6
2.7	INTERRUPT CONTROLLER Signals		2-6
2.8	LCD CONTROLLER Signals		2-7

2.9	UART Controller Signals	2-8
2.10	TIMER Signal	2-8
2.11	Pulse-Width Modulator Signal	2-8
2.12	Serial Peripheral Interface Signals	2-8
2.13	CHIP-SELECT Signals	2-9
2.14	In-Circuit EMULATion Signals	2-9

**SECTION 3
SYSTEM CONTROL**

3.1	Operation	3-1
3.2	Programming Model	3-2
3.2.1	System Control Register	3-2

**SECTION 4
CHIP-SELECT LOGIC**

4.1	Chip-Select Operation	4-2
4.1.1	Memory Protection	4-2
4.1.2	Programmable Data Bus Size	4-3
4.1.3	Overlapping Chip-Select Registers	4-4
4.2	PROGRAMMING MODEL	4-4
4.2.1	Chip-Select Group Base Address Registers	4-4
4.2.2	Chip-Select Registers	4-5
4.2.3	Emulation Chip-Select Register	4-8
4.3	Programming Example	4-9

**SECTION 5
PHASE-LOCKED LOOP AND POWER CONTROL**

5.1	Operation	5-2
5.1.1	Using the PLL To Reduce Power Consumption	5-2
5.1.2	PLL Operation at Power-Up	5-2
5.1.3	PLL Operation at Wake-Up	5-2
5.1.4	Changing the VCO Frequency	5-3
5.1.5	PLL Operation at System Shut-Down	5-3
5.2	Programming Model	5-4
5.2.1	PLL Control Register	5-4
5.2.2	PLL Frequency Select Register	5-5
5.3	POWER CONTROL	5-6
5.3.1	Operating the Power Control Module	5-8
5.3.2	Power Control Register	5-9

**SECTION 6
INTERRUPT CONTROLLER**

6.1	Interrupt Processing	6-1
6.2	Exception Vectors	6-3
6.3	Reset	6-4
6.3.1	DATA BUS WIDTH FOR BOOT DEVICE OPERATION	6-5
6.4	INTERRUPT CONTROLLER operation	6-5
6.5	Vector Generator	6-6
6.6	Programming Model	6-6
6.6.1	Interrupt Vector Register	6-6
6.6.2	Interrupt Control Register	6-7
6.6.3	Interrupt Mask Register	6-9
6.6.4	Interrupt Status Register	6-11
6.6.5	Interrupt Pending Register	6-16
6.7	KEYBOARD INTERRUPTS	6-20
6.8	PEN Interrupts	6-20

**SECTION 7
PARALLEL PORTS**

7.1	Operation	7-1
7.2	Programming Model	7-2
7.2.1	Port A Registers	7-2
7.2.2	Port B Registers	7-3
7.2.3	Port C Registers	7-5
7.2.4	Port D Registers	7-7
7.2.5	Port E Registers	7-10
7.2.6	Port F Registers	7-12
7.2.7	Port G Registers	7-14

**SECTION 8
PULSE-WIDTH MODULATOR**

8.1	Operation	8-1
8.1.1	Playback Mode	8-1
8.1.2	Tone Mode	8-2
8.1.3	D/A Mode	8-2
8.2	Programming Model	8-2
8.2.1	PWM Control Register	8-2
8.2.2	PWM Sample Register	8-5
8.2.3	PWM Period Register	8-5
8.2.4	PWM Counter Register	8-6
8.3	Programming Example	8-6

**SECTION 9
GENERAL-PURPOSE TIMER**

9.1	OPERATION	9-1
-----	-----------------	-----

9.2	Programming Model	9-2
9.2.1	Timer Control Register	9-2
9.2.2	Timer Prescaler Register	9-4
9.2.3	Timer Compare Register	9-4
9.2.4	Timer Capture Register	9-4
9.2.5	Timer Counter Register	9-5
9.2.6	Timer Status Register	9-5

**SECTION 10
SERIAL PERIPHERAL INTERFACE MASTER**

10.1	OPERATION	10-1
10.1.1	Phase/Polarity Configurations	10-2
10.1.2	Signals	10-3
10.2	Programming Model	10-3
10.2.1	SPIM Data Register	10-3
10.2.2	SPIM Control/Status Register	10-4
10.3	Programming Example	10-5

**SECTION 11
UNIVERSAL ASYNCHRONOUS RECEIVER/TRANSMITTER**

11.1	SERIAL OPERATION	11-2
11.1.1	NRZ Mode	11-2
11.1.2	IrDA Mode	11-2
11.1.3	SERIAL INTERFACE SIGNALS	11-3
11.2	SUB-BLOCK Operation	11-4
11.2.1	Transmitter	11-4
11.2.2	Receiver	11-5
11.2.3	Baud Rate Generator	11-6
11.3	Programming Model	11-8
11.3.1	UART Status/Control Register	11-8
11.3.2	UART Baud Control Register	11-11
11.3.3	UART Receiver Register	11-12
11.3.4	UART Transmitter Register	11-14
11.3.5	UART Miscellaneous Register	11-16
11.3.6	UART Non-Integer Prescaler Register	11-18
11.4	Non-Integer Prescaler Programming Example	11-19

**SECTION 12
LCD CONTROLLER**

12.1	Operation	12-2
12.1.1	Connecting the LCD Controller to an LCD Panel	12-3
12.1.2	Controlling the Display	12-4
12.1.3	Using Low-Power Mode	12-8

12.1.4	Using the DMA Controller	12-8
12.2	Programming Model	12-9
12.2.1	LCD Screen Starting Address Register	12-9
12.2.2	LCD Virtual Page Width Register	12-10
12.2.3	LCD Screen Width Register	12-10
12.2.4	LCD Screen Height Register	12-11
12.2.5	LCD Cursor X Position Register	12-11
12.2.6	LCD Cursor Y Position Register	12-12
12.2.7	LCD Cursor Width and Height Register	12-12
12.2.8	LCD Blink Control Register	12-13
12.2.9	LCD Panel Interface Configuration Register	12-13
12.2.10	LCD Polarity Configuration Register	12-14
12.2.11	LACD Rate Control Register	12-14
12.2.12	LCD Pixel Clock Divider Register	12-15
12.2.13	LCD Clocking Control Register	12-15
12.2.14	LCD Refresh Rate Adjustment Register	12-16
12.2.15	LCD Panning Offset Register	12-17
12.2.16	LCD Frame Rate Control Modulation Register	12-17
12.2.17	LCD Gray Palette Mapping Register	12-18
12.2.18	PWM Contrast Control Register	12-18
12.3	Programming EXAMPLE	12-19

**SECTION 13
REAL-TIME CLOCK**

13.1	Operation	13-2
13.1.1	Prescaler and Counter	13-2
13.1.2	Alarm	13-3
13.1.3	Watchdog Timer	13-3
13.1.4	Sampling Timer	13-3
13.1.5	Minute Stopwatch	13-4
13.2	Programming Model	13-4
13.2.1	RTC Hours, Minutes, and Seconds Register	13-4
13.2.2	RTC Alarm Register	13-5
13.2.3	Watchdog Timer Register	13-5
13.2.4	RTC Control Register	13-6
13.2.5	RTC Interrupt Status Register	13-7
13.2.6	RTC Interrupt Enable Register	13-9
13.2.7	Stopwatch Minutes Register	13-11
13.2.8	RTC Day Count Register	13-12
13.2.9	RTC Day Alarm Register	13-12

**SECTION 14
DRAM CONTROLLER**

14.1	OPERATION	14-2
------	-----------------	------

14.1.1	Address Multiplexing	14-2
14.1.2	DTACK Generation	14-3
14.1.3	Refresh Control	14-3
14.1.4	LCD Interface	14-3
14.1.5	8-Bit Mode	14-4
14.1.6	Low-Power Standby Mode	14-4
14.1.7	Data Retention During Reset	14-5
14.2	Programming Model	14-6
14.2.1	DRAM Memory Configuration Register	14-6
14.2.2	DRAM Control Register	14-8

**SECTION 15
IN-CIRCUIT EMULATION**

15.1	OPERATION	15-2
15.1.1	Entering Emulation Mode	15-2
15.1.2	Detecting Breakpoints	15-2
15.1.3	Using the Signal Decoder	15-3
15.1.4	Using the Interrupt Gate Module	15-3
15.1.5	Using the A-Line Insertion Unit	15-3
15.2	Programming Model	15-4
15.2.1	In-Circuit Emulation Module Address Compare/Mask Registers	15-4
15.2.2	In-Circuit Emulation Module Control Compare/Mask Register	15-5
15.2.3	In-Circuit Emulation Module Control Register	15-6
15.2.4	In-Circuit Emulation Module Status Register	15-8
15.3	Typical Design Programming Example	15-8
15.3.1	Host Interface	15-9
15.3.2	Dedicated Debug Monitor Memory	15-10
15.3.3	Emulation Memory Mapping FPGA and Emulation Memory	15-10
15.3.4	Optional Extra Hardware Breakpoint	15-10
15.3.5	Optional Trace Module	15-10
15.4	Plug-In Emulator Design Example	15-10
15.5	Application Development Design Example	15-12

**SECTION 16
BOOTSTRAP MODE**

16.1	operation	16-1
16.1.1	Entering Bootstrap Mode	16-1
16.1.2	Bootstrap Record Format	16-2
16.1.3	Setting Up the RS-232 Terminal	16-3
16.1.4	Changing the Speed of Communication	16-3
16.2	System Initialization Programming Example	16-3
16.3	Application Programming Example	16-4
16.4	Instruction Buffer Usage Example	16-5
16.5	Bootloader Flowchart	16-6

16.6 Special Notes 16-7

**SECTION 17
APPLICATION GUIDE**

17.1 Design Checklist 17-1
17.2 Using the MC68EZ328ADS Board 17-2

**SECTION 18
ELECTRICAL CHARACTERISTICS**

18.1 MAXIMUM RATINGS 18-1
18.2 DC ELECTRICAL CharacteristicS 18-1
18.3 AC ELECTRICAL Characteristics. 18-2
 18.3.1 CLKO reference to Chip-Select Signals Timing 18-2
 18.3.2 Chip-Select Read Cycle Timing 18-3
 18.3.3 Chip-Select Write Cycle Timing 18-4
 18.3.4 Chip-Select Flash Write Cycle Timing. 18-5
 18.3.5 DRAM Read Cycle 16-Bit Access (CPU Bus Master). 18-6
 18.3.6 DRAM Write Cycle 16-Bit Access (CPU Bus Master). 18-7
 18.3.7 DRAM Hidden Refresh Cycle (Normal Mode). 18-8
 18.3.8 DRAM Hidden Refresh Cycle (Low Power Mode) 18-9
 18.3.9 LCD SRAM/ROM DMA Cycle 16-Bit Mode Access(1 ws) (. 18-10
 18.3.10 LCD DRAM DMA Cycle 16-Bit EDO Mode Access (LCD Bus Master) 18-11
 18.3.11 LCD DRAM DMA Cycle 16-Bit Page Mode Access (LCD Bus Master) 18-12
 18.3.12 LCD Controller Timing. 18-13
 18.3.13 Normal Mode Timing. 18-14
 18.3.14 Normal Mode and Emulation Mode Timing. 18-14
 18.3.15 Emulation Mode Timing 18-14
 18.3.16 Bootstrap Mode Timing 18-15

**SECTION 19
MECHANICAL DATA AND ORDERING INFORMATION**

19.1 Ordering Information. 19-1
19.2 TQFP Pin Assignments 19-2
19.3 TQFP Package Dimensions 19-2
19.4 PBGA Pin Assignments 19-4
19.5 PBGA Package Dimensions. 19-4

LIST OF ILLUSTRATIONS

Figure Number	Title	Page Number
1-1	MC68EZ328 Block Diagram	1-2
1-2	User Programming Model	1-3
1-3	Supervisor Programming Model Supplement	1-3
1-4	MC68EZ328 System Memory Map	1-9
2-1	Signals Grouped by Function	2-2
2-2	Typical Crystal Connection	2-4
4-1	Chip-Selects and Memory Types	4-1
4-2	Size Selection and Memory Protection for CSB0 and CSB1	4-3
5-1	PLL Block Diagram	5-1
5-2	Power Control Module Block Diagram	5-7
5-3	Power Control Operation.	5-8
6-1	Interrupt Processing Flowchart	6-2
7-1	Parallel Port Operation	7-1
7-2	Interrupt Port Operation	7-7
8-1	Pulse-Width Modulator Block Diagram	8-1
8-2	Audio Waveform Generation.	8-2
9-1	General-Purpose Timer Block Diagram	9-1
10-1	Serial Peripheral Interface Master Block Diagram	10-1
10-2	Serial Peripheral Interface Master Operation	10-2
11-1	UART Block Diagram	11-2
11-2	NRZ ASCII "A" Character with Odd Parity	11-2
11-3	IrDA ASCII "A" Character with Odd Parity.	11-3
11-4	Baud Rate Generator Block Diagram	11-6
12-1	LCD Controller Block Diagram	12-2
12-2	LCD Interface Timing for 4-, 2-, and 1-Bit Data Widths.	12-4
12-3	LCD Screen Format	12-5
12-4	Mapping Memory Data on the Screen	12-6
13-1	Real-Time Clock Block Diagram	13-2
14-1	DRAM Controller Block Diagram	14-1
14-2	DRAM Address Multiplexer Options.	14-2

Freescale Semiconductor, Inc.

14-3	LCD Controller and DRAM Controller Interface	14-4
14-4	Data Retention for the Reset Cycle	14-5
15-1	In-Circuit Emulation Module Block Diagram	15-1
15-2	Typical Emulator Design Example	15-9
15-3	Plug-in Emulator Design Example	15-11
15-4	Application Development System Design Example	15-12
16-1	Bootstrap Mode Reset Timing	16-2
16-2	Bootloader Program Operation	16-6
19-1	Top View	19-2

LIST OF TABLES

Table Number	Title	Page Number
1-1	Address Modes	1-4
1-2	Instruction Set	1-5
1-3	Programmer's Memory Map	1-10
2-1	Signal Function Groups.	2-3
6-1	Exception Vector Assignment	6-3
6-2	Interrupt Vector Numbers	6-6
11-1	Non-Integer Prescaler Values.	11-7
11-2	Non-Integer Prescaler Settings.	11-7
11-3	Selected Baud Rate Settings	11-7
12-1	Gray-Scale Palette Options.	12-7
13-1	Sampling Timer Frequencies	13-3

PREFACE

The MC68EZ328 (DragonBallEZ) microprocessor, which is the second generation of the DragonBall™, is designed to save you time, power, cost, board space, pin count, and programming steps when designing your product. This functionality on a different microprocessor could require 20 separate components, each with 16-64 separate pins. These components take up valuable space on your board and they also consume more power. In addition, the signals between the CPU and a peripheral could be incompatible and may not run from the same clock, which could require time delays or other special design constraints.

All this combined makes the MC68EZ328 the microprocessor of choice among many system designers. Its functionality and glue logic are all optimally connected, timed with the same clock, fully tested, and uniformly documented. Also, only the essential signals are brought out to the pins. The MC68EZ328's primary package consists of a surface-mount plastic TQFP designed to leave the smallest possible footprint on your board.

RELATED DOCUMENTATION

This manual will discuss the details of how to initialize, configure, and program the MC68EZ328 microprocessor. However, it assumes you have a basic knowledge of 68K architecture. If you are not familiar with 68K, you should get a copy of the following documents to use in conjunction with this manual.

- M68000 User's Manual (part number M68000UM/AD).
- M68EZ328ADS User's Manual, which is only available from our website.
- M68000 Programmer's Reference Manual (part number M68000PM/AD).

You can go to the Motorola website at www.mot.com/dragonball and download these documents or you can contact your local sales office and request a printed version. The website also has application notes that may be useful to you.

ORGANIZATION OF THIS MANUAL

This manual is organized according to the MC68EZ328 memory map, which is discussed in [Section 1.15 Memory Map](#).

SECTION 1 BASIC ARCHITECTURE

To improve total system throughput and reduce component count, board size, and cost of system implementation, the MC68EZ328 combines a powerful MC68EC000 processor with intelligent peripheral modules and a typical system interface logic. The architecture of the MC68EZ328 consists of the following blocks:

- EC000 core
- Chip-select logic and bus interface
- Phase-locked loop and power control
- Interrupt controller
- Parallel general-purpose I/O ports
- Pulse-width modulator
- General-purpose timer
- Serial peripheral interface
- UART and infra-red communication support
- LCD controller
- Real-time clock
- DRAM controller
- In-circuit emulation module
- Bootstrap mode

This manual assumes you are familiar with 68K architecture. If you are not, get a copy of the M68000 User's Manual (part number M68000UM/AD) and M68000 Programmer's Reference Manual (part number M68000PM/AD) from your local Motorola sales office.

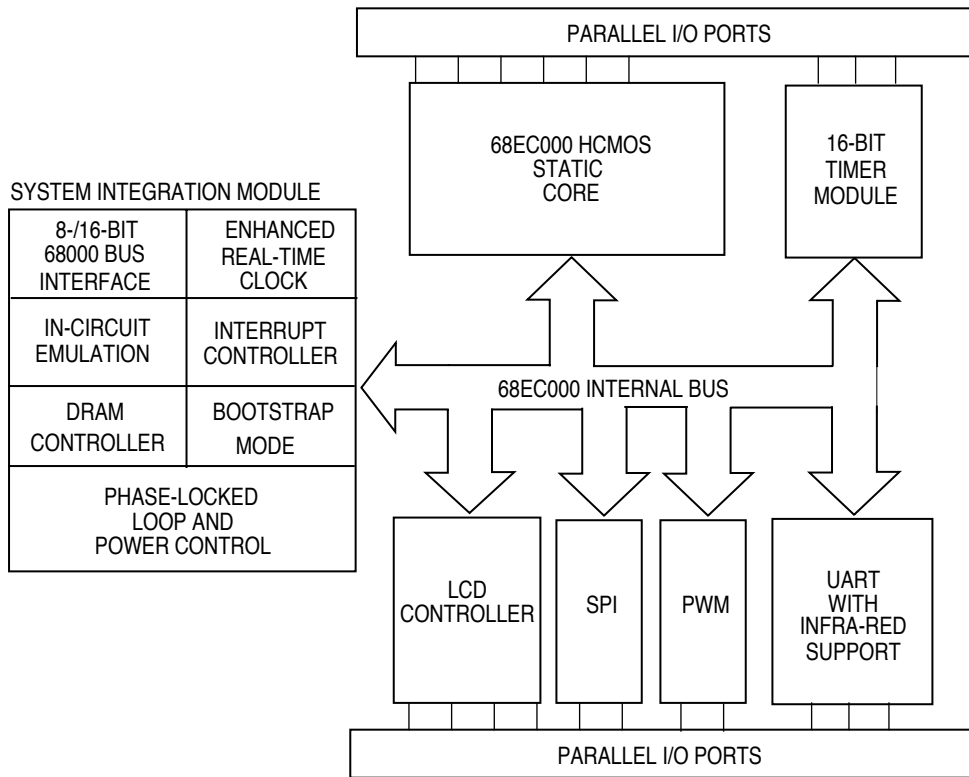

Figure 1-1. MC68EZ328 Block Diagram

1.1 CORE

The MC68EC000 core in the MC68EZ328 is an updated implementation of the M68000 32-bit microprocessor architecture. The main features of the core are:

- Low power, static HCMOS implementation
- 32-bit address bus and 16-bit data bus
- Sixteen 32-bit data and address registers
- 56 powerful instruction types that support high-level development languages
- 14 addressing modes and five main data types
- Seven priority levels for interrupt control

The core is completely code-compatible with other members of the M68000 families, which means it has access to a broad base of established real-time kernels, operating systems, languages, applications, and development tools.

1.1.1 Core Programming Model

The core has 32-bit registers and a 32-bit program counter, which are shown in Figure 1-2. The first eight registers (D7–D0) are data registers that are used for byte (8-bit), word (16-bit), and long-word (32-bit) operations. When using the data registers to manipulate data, they affect the status register (SR). The next seven registers (A6–A0) and the user

stack pointer (USP) can function as software stack pointers and base address registers. These registers can be used for word and long-word operations, but they do not affect the status register. The D7-D0 and A6-A0 registers can be used as index registers.

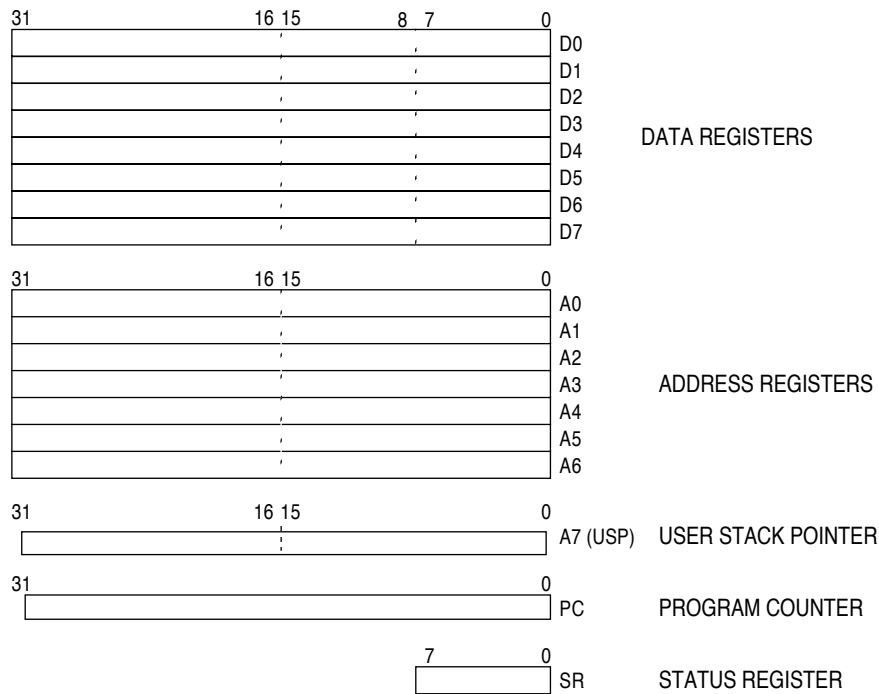

Figure 1-2. User Programming Model

In supervisor mode, the upper byte of the status register and the supervisor stack pointer (SSP) can also be programmed, as shown in Figure 1-3.

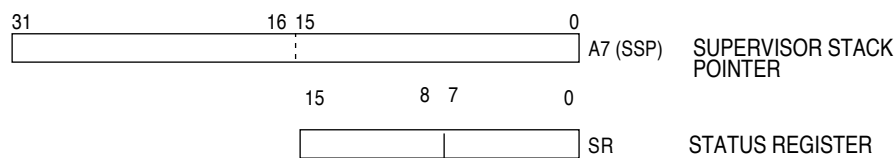

Figure 1-3. Supervisor Programming Model Supplement

The status register contains the interrupt mask with seven available levels, as well as an extend (X), negative (N), zero (Z), overflow (V), and carry (C) condition code. The T bit indicates when the processor is in trace mode and the S bit indicates when it is in supervisor or user mode.

1.1.2 Data and Address Mode Types

The core supports five types of data and six main types of address modes, as described in the following tables.

DATA TYPES	ADDRESS MODE TYPES
Bits	Register direct
Binary-coded decimal digits	Register indirect
Bytes	Absolute
Words	Program counter relative
Long words	Immediate
	Implied

Table 1-1. Address Modes

ADDRESS MODE	SYNTAX
Register direct address Data register direct Address register direct	Dn An
Absolute data address Absolute short Absolute long	xxx.W xxx.L
Program counter relative address Relative with offset Relative with index offset	d ₁₆ (PC) d ₈ (PC, Xn)
Register indirect address register Register indirect Postincrement register indirect Predecrement register indirect Register indirect with offset Indexed register indirect with offset	(An) (An)+ -(An) d ₁₆ (An) d ₈ (An, Xn)
Immediate data address Immediate Quick immediate	#xxx #1-#8
Implied address Implied register	SR/USP/SP/PC

NOTE:

- Dn = Data Register
- An = Address Register
- Xn = Address or Data Register Used as Index Register
- SR = Status Register
- PC = Program Counter
- SP = Stack Pointer
- USP = User Stack Pointer
- <> = Effective Address
- d₈ = 8-Bit Offset (Displacement)
- d₁₆ = 16-Bit Offset (Displacement)
- #xxx = Immediate Data

1.1.3 EC000 Instruction Set

The EC000 core instruction set supports high-level languages that facilitate programming. Almost every instruction operates on bytes, words, and long-words, and most of them can use any of the 14 address modes. By combining instruction types, data types, and address modes, you can have access to over 1,000 instructions. These instructions include signed and unsigned, multiply and divide, quick arithmetic operations, binary-coded decimal (BCD) arithmetic, and expanded operations (through traps).

Table 1-2. Instruction Set

MNEMONIC	DESCRIPTION	MNEMONIC	DESCRIPTION
ABCD	Add decimal with extend	MOVEM	Move multiple registers
ADD	Add	MOVEP	Move peripheral data
ADDA	Add address	MOVEQ	Move quick
ADDQ	Add quick	MOVE from SR	Move from status register
ADDI	Add immediate	MOVE to SR	Move to status register
ADDX	Add with extend	MOVE to CCR	Move to condition codes
AND	Logical AND	MOVE USP	Move user stack pointer
ANDI	AND immediate	MULS	Signed multiply
ANDI to CCR	AND immediate to condition codes	MULU	Unsigned multiply
ANDI to SR	AND immediate to status register	NBCD	Negate decimal with extend
ASL	Arithmetic shift left	NEG	Negate
ASR	Arithmetic shift right	NEGX	Negate with extend
Bcc	Branch conditionally	NOP	No operation
BCHG	Bit test and change	NOT	Ones complement
BCLR	Bit test and clear	OR	Logical OR
BRA	Branch always	ORI	OR immediate
BSET	Bit test and set	ORI to CCR	OR immediate to condition codes
BSR	Branch to subroutine	ORI to SR	OR immediate to status register
BTST	Bit test	PEA	Push effective address
CHK	Check register against bounds	RESET	Reset external devices
CLR	Clear operand	ROL	Rotate left without extend
CMP	Compare	ROR	Rotate right without extend
CMPA	Compare address	ROXL	Rotate left with extend
CMPM	Compare memory	ROXR	Rotate right with extend
CMPI	Compare immediate	RTE	Return from exception
DBcc	Test cond, decrement and branch	RTR	Return and restore
DIVS	Signed divide	RTS	Return from subroutine
DIVU	Unsigned divide	SBCD	Subtract decimal with extend

Table 1-2. Instruction Set (Continued)

MNEMONIC	DESCRIPTION	MNEMONIC	DESCRIPTION
EOR	Exclusive OR	ScC	Set conditional
EORI	Exclusive OR immediate	STOP	Stop
EORI to CCR	Exclusive OR immediate to condition codes	SUB	Subtract
EORI to SR	Exclusive OR immediate to status register	SUBA	Subtract address
EXG	Exchange registers	SUBI	Subtract immediate
EXT	Sign extend	SUBQ	Subtract quick
JMP	Jump	SUBX	Subtract with extend
JSR	Jump to subroutine	SWAP	Swap data register halves
LEA	Load effective address	TAS	Test and set operand
LINK	Link stack	TRAP	Trap
LSL	Logical shift left	TRAPV	Trap on overflow
LSR	Logical shift right	TST	Test
MOVE	Move	UNLK	Unlink
MOVEA	Move address		

1.2 CHIP-SELECT LOGIC AND BUS INTERFACE

The system control register (SCR) allows you to configure the system status and control logic, register double-mapping, bus error generation, and module control register protection on the MC68EZ328.

The MC68EZ328 contains eight programmable general-purpose chip-select signals. Each chip-select block allows you to choose whether the chip-select allows read-only or both read and write accesses, whether a \overline{DTACK} signal is automatically generated for the chip-select, the number of wait states (from zero to six) until the \overline{DTACK} will be generated, and an 8- or 16-bit data bus.

The external bus interface handles the transfer of information between the internal core and the memory, peripherals, or other processing elements in the external address space. It consists of a 16-bit M68000 data bus interface for internal-only devices and an 8- or 16-bit (or mixed) data bus interface to external devices.

1.3 PHASE-LOCKED LOOP AND POWER CONTROL

The clock synthesizer can operate with either an external crystal or an external oscillator using an internal phase-locked loop (PLL). An external clock can also be used to directly drive the clock signal at the operational frequency.

You can save power on the MC68EZ328 by turning off peripherals that are not being used, reducing processor clock speed, or disabling the processor altogether. An interrupt at the

interrupt controller logic that runs during low-power mode allows you to wake up from this mode. Programmable interrupt sources cause the system to wake up. On-chip peripherals can initiate a wake-up from doze mode and the external interrupts and real-time clock can wake up the core from sleep mode.

1.4 INTERRUPT CONTROLLER

The interrupt controller prioritizes internal and external interrupt requests and generates a vector number during the CPU interrupt-acknowledge cycle. Interrupt nesting is also provided so that an interrupt service routine of a lower priority interrupt may be suspended by a higher priority interrupt request. The on-chip interrupt controller has the following features:

- Prioritized interrupts
- Fully nested interrupt environment
- Programmable vector generation
- Unique vector number generated for each interrupt level
- Interrupt/wakeup masking

1.5 PARALLEL GENERAL-PURPOSE I/O PORTS

The MC68EZ328 supports a maximum of 45 general-purpose I/O ports that you can configure as general-purpose I/O pins or dedicated peripheral interface pins. Each pin can be independently programmed as a general-purpose I/O pin even when other pins related to that on-chip peripheral are used as dedicated pins. If all the pins for a particular peripheral are configured as general-purpose I/O, the peripheral will still operate normally.

1.6 PULSE-WIDTH MODULATOR

The pulse-width modulator (PWM) can be used to generate sound. The 5-byte FIFO can enhance performance by allowing the CPU to service other interrupts while data is being supplied to the PWM.

1.7 GENERAL-PURPOSE TIMER

The free-running 16-bit timer can be used in various modes to capture the timer value with an external event, to trigger an external event or interrupt when the timer reaches a set value, or to count external events. The timer has an 8-bit prescaler to allow a programmable clock input frequency to be derived from the system clock.

1.8 SERIAL PERIPHERAL INTERFACE

The serial peripheral interface (SPI) is mainly used for controlling external peripherals. The passed data is synchronized with the SPI clock and it is transmitted and received with the same SPI clock. The SPI module is only in master mode, which initiates SPI transfers from the MC68EZ328 to the peripheral.

1.9 UART AND INFRA-RED COMMUNICATION SUPPORT

The UART communicates with external devices with a standard asynchronous protocol at baud rates from 300 bps to 1152 kbps. The UART provides the pulses to directly drive standard IrDA transceivers.

1.10 LCD CONTROLLER

The LCD controller is used to display data on an LCD module. It fetches display data from memory and provides control signals, frame line pulse, clocks, and data to the LCD module. It supports monochrome STN LCD modules with a maximum of sixteen gray levels with frame rate control. System RAM can be used as display memory and DMA frees the CPU from panel refresh responsibilities.

1.11 REAL-TIME CLOCK

A real-time clock provides time-of-day with one-second resolution. It uses the crystal (either 32.768 KHz or 38.4kHz) as a clock source to keep proper time. It keeps time as long as power is applied to the chip, which can be in sleep or doze mode. The software watchdog timer protects against system failures by providing a way for you to escape from unexpected input conditions, external events, or programming errors. Once started, the software watchdog timer must be cleared by software on a regular basis so that it never reaches its time-out value. When it does reach its time-out value, the watchdog timer assumes that a system failure has occurred and the software watchdog logic resets or interrupts the core.

1.12 DRAM CONTROLLER

The MC68EZ328 DRAM controller provides a glueless interface to most DRAM chips on the market. It supports one or two banks of DRAM and each bank can be a maximum of 4 Mbyte.

1.13 IN-CIRCUIT EMULATION MODULE

The in-circuit emulation module is designed for low-cost emulator development purposes. System memory space, which is 0xFFFC0000 to 0xFFDFFFFF, is covered by the $\overline{\text{EMUCS}}$ signal and primarily dedicated to the emulator debug monitor. However, you can use the $\overline{\text{EMUCS}}$ signal to select the monitor ROM or system I/O port. Keep in mind that if you select the monitor ROM, the system must boot up in emulator mode.

1.14 BOOTSTRAP MODE

Bootstrapping allows you to use the UART port to download data/programs to system memory without a preloaded monitor or boot code. You can also perform some simple hardware debug functions on your target system using the bootstrap utility program BBUG.EXE, which is available on our website.

1.15 MEMORY MAP

The memory map is a guide to all on-chip resources. Use the following figure and table as a guide when you configure your chip. The base address used in the table is 0xFFFFF00 and 0xFFF000 from reset. If a double-mapped bit is cleared in the system control register,

then the base address is 0xFFFFF000. Unpredictable results occur if you write to any 4K register space not documented in Table 1-3.

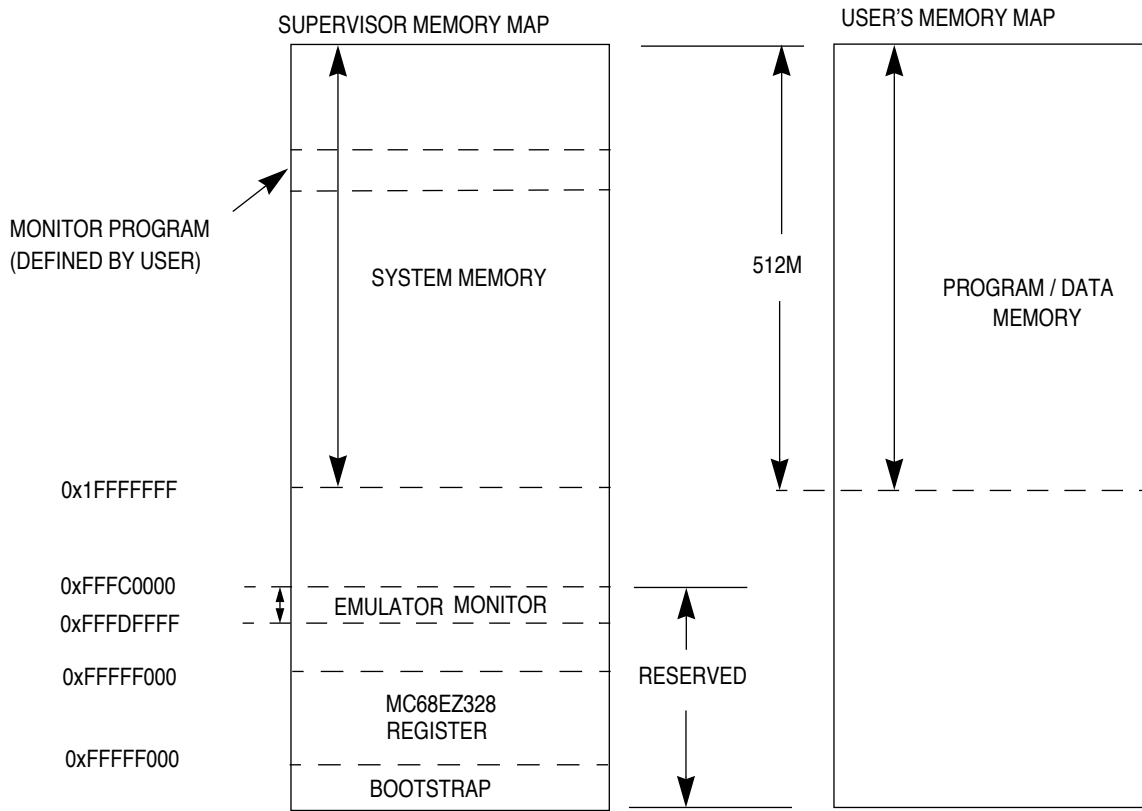

Figure 1-4. MC68EZ328 System Memory Map

Table 1-3. Programmer's Memory Map

ADDRESS	NAME	WIDTH	DESCRIPTION	RESET VALUE	PAGE #
0xFFFFF000	SCR	8	System Control Register	0x1C	-2
0xFFFFF004	ID	32	Silicon ID Register	—	—
0xFFFFF100	CSGBA	16	Chip Select Group A Base Register	0x0000	-4
0xFFFFF102	CSGBB	16	Chip Select Group B Base Register	0x0000	-4
0xFFFFF104	CSGBC	16	Chip Select Group C Base Register	0x0000	-4
0xFFFFF106	CSGBD	16	Chip Select Group D Base Register	0x0000	-4
0xFFFFF110	CSA	16	Group A Chip-Select Register	0x00E0	-5
0xFFFFF112	CSB	16	Group B Chip-Select Register	0x0000	-5
0xFFFFF114	CSC	16	Group C Chip-Select Register	0x0000	-5
0xFFFFF116	CSD	16	Group D Chip-Select Register	0x0200	-5
0xFFFFF118	EMUCS	16	Emulation Chip-Select Register	0x0060	-8
0xFFFFF200	PLLCR	16	PLL Control Register	0x2430	-4
0xFFFFF202	PLLFSR	16	PLL Frequency Select Register	0x0123	-5
0xFFFFF204	RES	—	Reserved	—	—
0xFFFFF207	PCTLR	8	Power Control Register	0x1F	-9
0xFFFFF300	IVR	8	Interrupt Vector Register	0x00	-6
0xFFFFF302	ICR	16	Interrupt Control Register	0x0000	-7
0xFFFFF304	IMR	32	Interrupt Mask Register	0x00FFFFFF	-9
0xFFFFF308	RES	32	Reserved	—	—
0xFFFFF30C	ISR	32	Interrupt Status Register	0x00000000	-11
0xFFFFF310	IPR	32	Interrupt Pending Register	0x00000000	-16
0xFFFFF400	PADIR	8	Port A Direction Register	0x00	-2
0xFFFFF401	PADATA	8	Port A Data Register	0x00	-2
0xFFFFF402	PAPUEN	8	Port A Pull-Up Enable Register	0xFF	-2
0xFFFFF403	RES	8	Reserved	—	—
0xFFFFF408	PBDIR	8	Port B Direction Register	0x00	-3
0xFFFFF409	PBDATA	8	Port B Data Register	0x00	-3
0xFFFFF40A	PBPUEN	8	Port B Pull-Up Enable Register	0xFF	-3
0xFFFFF40B	PBSEL	8	Port B Select Register	0xFF	-3
0xFFFFF410	PCDIR	8	Port C Direction Register	0x00	-5
0xFFFFF411	PCDATA	8	Port C Data Register	0x00	-5
0xFFFFF412	PCPDEN	8	Port C Pull-Down Enable Register	0xFF	-5
0xFFFFF413	PCSEL	8	Port C Select Register	0xFF	-5
0xFFFFF418	PDDIR	8	Port D Direction Register	0x00	-7
0xFFFFF419	PDDATA	8	Port D Data Register	0x00	-7

Table 1-3. Programmer's Memory Map (Continued)

ADDRESS	NAME	WIDTH	DESCRIPTION	RESET VALUE	PAGE #
0xFFFF41A	PDPUEN	8	Port D Pull-Up Enable Register	0xFF	-7
0xFFFF41B	PDSEL	8	Port D Select Register	0xF0	-7
0xFFFF41C	PDPOL	8	Port D Polarity Register	0x00	-7
0xFFFF41D	PDIRQEN	8	Port D Interrupt Request Enable Register	0x00	-7
0xFFFF41E	PDKBEN	8	Port D Keyboard Enable Register	0x00	-7
0xFFFF41F	PDIRQEG	8	Port D Interrupt Request Edge Register	0x00	-7
0xFFFF420	PEDIR	8	Port E Direction Register	0x00	-10
0xFFFF421	PEDATA	8	Port E Data Register	0x00	-10
0xFFFF422	PEPUEN	8	Port E Pull-Up Enable Register	0xFF	-10
0xFFFF423	PESEL	8	Port E Select Register	0xFF	-10
0xFFFF428	PFDIR	8	Port F Direction Register	0x00	-12
0xFFFF429	PFDATA	8	Port F Data Register	0x00	-12
0xFFFF42A	PFPUEN	8	Port F Pull-Up Enable Register	0xFF	-12
0xFFFF42B	PFSEL	8	Port F Select Register	0x00	-12
0xFFFF430	PGDIR	8	Port G Direction Register	0x00	-14
0xFFFF431	PGDATA	8	Port G Data Register	0x00	-14
0xFFFF432	PGPUEN	8	Port G Pull-Up Enable Register	0x3D	-14
0xFFFF433	PGSEL	8	Port G Select Register	0x08	-14
0xFFFF500	PWMC	16	PWM Control Register	0x0020	-2
0xFFFF502	PWMS	16	PWM Sample Register	0xxxxx	-5
0xFFFF504	PWMP	8	PWM Period Register	0xFE	-5
0xFFFF505	PWMCNT	8	PWM Counter Register	0x00	-6
0xFFFF506	RES	16	Reserved	—	—
0xFFFF600	TCTL	16	Timer Control Register	0x0000	-2
0xFFFF602	TPRER	16	Timer Prescaler Register	0x0000	-4
0xFFFF604	TCMP	16	Timer Compare Register	0xFFFF	-4
0xFFFF606	TCR	16	Timer Capture Register	0x0000	-4
0xFFFF608	TCN	16	Timer Counter Register	0x0000	-5
0xFFFF60A	TSTAT	16	Timer Status Register	0x0000	-5
0xFFFF800	SPIMDATA	16	SPIM Data Register	0x0000	-3
0xFFFF802	SPIMCONT	16	SPIM Control/Status Register	0x0000	-4
0xFFFF900	USTCNT	16	UART Status/Control Register	0x0000	-8
0xFFFF902	UBAUD	16	UART Baud Control Register	0x003F	-11
0xFFFF904	URX	16	UART Receiver Register	0x0000	-12
0xFFFF906	UTX	16	UART Transmitter Register	0x0000	-14

Table 1-3. Programmer's Memory Map (Continued)

ADDRESS	NAME	WIDTH	DESCRIPTION	RESET VALUE	PAGE #
0xFFFFF908	UMISC	16	UART Miscellaneous Register	0x0000	-16
0xFFFFF90A	NIPR	16	UART Non-Integer Prescaler Register	0x0000	-18
0xFFFFFA00	LSSA	32	LCD Screen Starting Address Register	0x00000000	-9
0xFFFFFA05	LVPW	8	LCD Virtual Page Width Register	0xFF	-10
0xFFFFFA08	LXMAX	16	LCD Screen Width Register	0x03FF	-10
0xFFFFFA0A	LYMAX	16	LCD Screen Height Register	0x01FF	-11
0xFFFFFA18	LCXP	16	LCD Cursor X Position Register	0x0000	-11
0xFFFFFA1A	LCYP	16	LCD Cursor Y Position Register	0x0000	-12
0xFFFFFA1C	LCWCH	16	LCD Cursor Width and Height Register	0x0101	-12
0xFFFFFA1F	LBLKC	8	LCD Blink Control Register	0x7F	-13
0xFFFFFA20	LPICF	8	LCD Panel Interface Configuration Register	0x00	-13
0xFFFFFA21	LPOLCF	8	LCD Polarity Configuration Register	0x00	-14
0xFFFFFA23	LACDRC	8	LACD Rate Control Register	0x00	-14
0xFFFFFA25	LPXCD	8	LCD Pixel Clock Divider Register	0x00	-15
0xFFFFFA27	LCKCON	8	LCD Clocking Control Register	0x40	-15
0xFFFFFA29	LRRA	8	LCD Refresh Rate Adjustment Register	0xFF	-16
0xFFFFFA2B	RES	8	Reserved	—	—
0xFFFFFA2D	LPOSR	8	LCD Panning Offset Register	00	-17
0xFFFFFA31	LFRCM	8	LCD Frame Rate Control Modulation Register	0xB9	-17
0xFFFFFA33	LGPMR	8	LCD Gray Palette Mapping Register	0x84	-18
0xFFFFFA36	PWMR	16	PWM Contrast Control Register	0x0000	-18
0xFFFFFB00	RTCTIME	32	RTC Hours, Minutes, and Seconds Register	0x00000000	-4
0xFFFFFB04	RTCALRM	32	RTC Alarm Register	0x00000000	-5
0xFFFFFB0A	WATCHDOG	16	Watchdog Timer Register	0x0001	-5
0xFFFFFB0C	RTCCTL	8	RTC Control Register	0x00	-6
0xFFFFFB0E	RTCISR	8	RTC Interrupt Status Register	0x00	-7
0xFFFFFB10	RTCIENR	8	RTC Interrupt Enable Register	0x00	-9
0xFFFFFB12	STPWCH	8	Stopwatch Minutes Register	0x00	-11
0xFFFFFB1A	DAYR	16	RTC Day Count Register	0x0xxx	-12
0xFFFFFB1C	DAYALARM	16	RTC Day Alarm Register	0x0000	-12
0xFFFFFC00	DRAMMC	16	DRAM Memory Configuration Register	0x00000000	-6
0xFFFFFC02	DRAMC	16	DRAM Control Register	0x00000000	-8
0xFFFFFC80	RES	—	Reserved	—	—
0xFFFFFD00	ICEMACR	32	ICEM Address Compare Register	0x00000000	-4
0xFFFFFD04	ICEMAMR	32	ICEM Address Mask Register	0x00000000	-4

Table 1-3. Programmer's Memory Map (Continued)

ADDRESS	NAME	WIDTH	DESCRIPTION	RESET VALUE	PAGE #
0xFFFFFD08	ICEMCCR	16	ICEM Control Compare Register	0x0000	-5
0xFFFFFD0A	ICEMCMR	16	ICEM Control Mask Register	0x0000	-5
0xFFFFFD0C	ICEMCR	16	ICEM Control Register	0x0000	-6
0xFFFFFD0E	ICEMSR	16	ICEM Status Register	0x0000	-8
0xFFFFFExx	Bootloader	—	Bootloader Microcode Space	—	-3

SECTION 2

SIGNAL DESCRIPTIONS

This section describes the MC68EZ328's input and output signals, which are organized into functional groups, as illustrated in Figure 2-1. The MC68EZ328 uses a standard M68000 bus to communicate with on-chip and external peripherals, with an optional address extension to the A23 signal. This single continuous bus exists both on and off the chip. Read accesses made by the core to internal memory-mapped registers of the device are invisible on the external bus, but write accesses made by the core to internal or external memory-mapped locations are not invisible.



Note: The terms “assertion” and “negation” are used extensively throughout this section to avoid confusion when dealing with a mixture of active low and active high signals. The terms “assert” and “assertion” are used to indicate that a signal is active or true, regardless of whether that level is represented by a high or low voltage. The terms “negate” and “negation” are used to indicate that a signal is inactive or false.

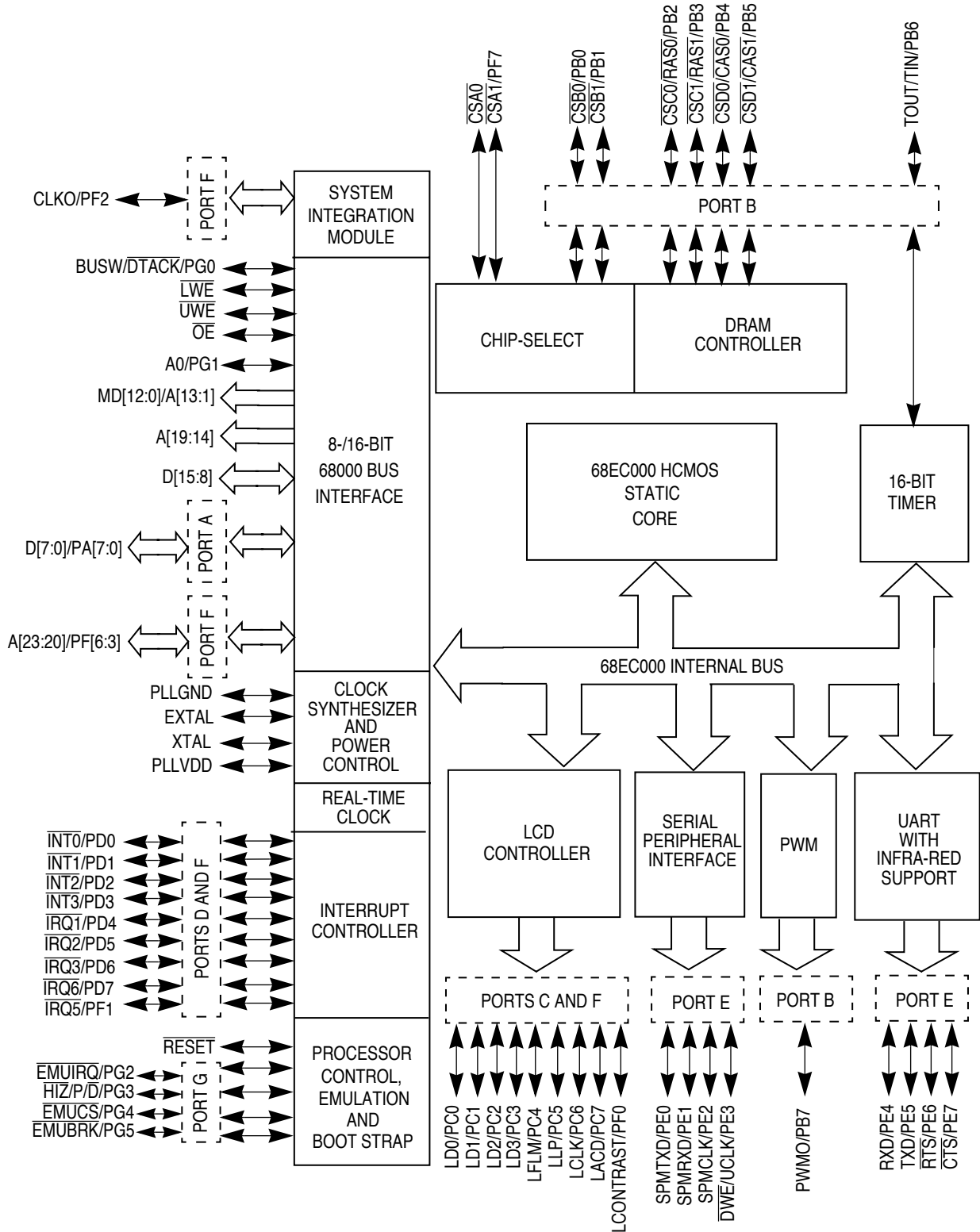

Figure 2-1. Signals Grouped by Function

2.1 SIGNALS GROUPED BY FUNCTION

The MC68EZ328 signals are grouped according to their function in Table 2-1.

Table 2-1. Signal Function Groups

FUNCTION GROUP	SIGNALS	NUMBER OF PINS
Power	V _{DD} , PLLV _{DD}	6
Ground	V _{SS} , PLLV _{SS}	6
Clocks/PCIO	XTAL, EXTAL, CLKO/PF2	3
System Control	RESET	1
Address Bus/PFIO	PF[3:6]/A[23:20], A[19:14], A0/PG1, MD[12:0]/A[13:1]	24
Lower Data Bus/PAIO	PA[7:0]/D[7:0]	8
Upper Data Bus	D[15:6]	8
Bus Control/PCIO/PEIO	BUSW/DTACK/PG0, OE, LWE, UWE, DWE	5
Interrupt Controller/PMIO	INT0/PD0, INT1/PD1, INT2/PD2, INT3/PD3, IRQ1/PD4, IRQ2/PD5, IRQ3/PD6, IRQ6/PD7, IRQ5/PF1	9
LCD Controller/PCIO	LACD/PC7, LCLK/PC6, LLP/PC5, LFLM/PC4, LD[3:0]/PC[3:0], LCONTRAST/PF0	9
UART/PEIO	RXD/PE4, TXD/PE5, RTS/PE6, CTS/PE7, UCLK/PE3	5
Timer/PBIO	TOUT/TIN/PB6	1
Pulse-Width Modulator/PBIO	PWMO/PB7	1
Serial Peripheral Interface/PEIO	SPMTXD/PE0, SPMRXD/PE1, SPMCLK/PE2	3
Chip-Select	CSA[1:0]/PF7, CSB[1:0]/PB[0:1], CSC[1:0]/PB[3:2], CSD[1:0]/PB[5:4]	8
Emulator Pins	EMUIRQ/PG2, EMUBRK/PG5, HIZ/P/D/PG3, EMUCS/PG4	4



Note: All pins, except EXTAL, support TTL levels. When EXTAL is used as an input clock, it needs a CMOS level. To ensure proper low-power operation, all inputs should be driven to CMOS level. More power is consumed when you use a TTL level to drive those inputs.

2.2 POWER AND GROUND SIGNALS

The MC68EZ328 microprocessor has 12 power supply pins. You should try to maintain a low level of noise, potential crosstalk, and RF radiation from the output drivers.

- V_{DD} has five power pins.
- V_{SS} has five ground pins.
- PLL_{DD} has one power pin for the PLL.
- PLL_{SS} has one ground pin for the PLL.

2.3 CLOCK AND SYSTEM CONTROL SIGNALS

- **EXTAL**—External Clock/Crystal. This input signal connects to the external low frequency crystal. The MC68EZ328 microprocessor supports both a 32.768kHz or 38.4kHz crystal frequency. For a 32.768kHz input, the internal phase-locked loop (PLL) generates the PLL output clock at 16.58MHz. Figure 2-2 illustrates how a crystal is usually connected to the MC68EZ328.

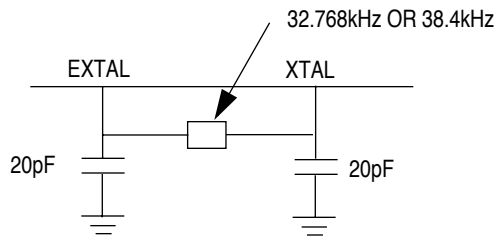

Figure 2-2. Typical Crystal Connection

- **XTAL**—Crystal. This output signal connects the on-chip oscillator output to an external crystal.
- **CLKO/PF2**—Clock Out and Bit 2 of Port F. This output clock signal is derived from the on-chip clock oscillator and is internally connected to the clock output of the internal PLL. This signal is provided for external reference. The output can be disabled to reduce power consumption and electromagnetic emission. This signal defaults to a PF2 input signal.
- **RESET**—Reset. This active-low schmitt trigger input signal resets the entire MC68EZ328 processor (CPU and peripherals). After power-up, you should drive this signal low for at least 250msec to ensure that the crystal oscillator starts and stabilizes. This signal is inactive while the core is executing the **reset** instruction. When you are using an R/C circuit to generate this input signal to the MC68EZ328, the R/C circuit must be as close to the chip as possible.

2.4 ADDRESS BUS SIGNALS

The address bus pins A[23-0] are the address lines driven by the core or LCD controller for panel refresh DMA. The internal chip-select module can decode a maximum 16M address map. In sleep mode, all address signals are in an active state of the last bus cycle.

- **A0/PG1**—Address 0 and Port G Bit 1. After system reset, this signal defaults to A0.
- **A[19:14]**—Address Bits 19-14. These address output lines are not multiplexed with any other I/O signal.
- **A[23:20]/PF[6:3]**—Address Bits 23-20 and Port F Bits 6-3. These address lines are multiplexed with I/O Port F. When programmed as I/O ports, they serve as general-purpose I/O ports. Otherwise, they are output-only address signals. These signals default to general-purpose I/O input and are pulled down with 100K resistors after reset.

2.5 DATA BUS SIGNALS

The flexible data bus interface design of the MC68EZ328 microprocessor allows you to program the lower byte of the data bus (in an 8-bit-only system) as general-purpose I/O signals. In sleep mode, all of the data bus pins (D15-D0) are individually pulled up with 100K Ohms resistors.

- **D[15:8]**—Data Bits 15-8. The upper byte of the data bus is not multiplexed with any other signal. In pure 8-bit systems, this is the data bus. In mixed 8- and 16-bit systems, 8-bit memory blocks or peripherals should be connected to this bus.
- **D[7:0]/PA[7:0]**—Data Bits 7-0 and Port A Bits 7-0. This bus is the lower data byte or general-purpose I/O. In pure 8-bit systems, this bus can serve as a general-purpose I/O. The WDT8 bit in the system control register (0xFFF000) should be set to one by software before the port can be used. In 16-bit or mixed 8- and 16-bit systems, these pins must function as the lower data byte.
- **MD[12:0]/A[13:1]**—Multiplexed DRAM Bits 12-0 and Address Bits 13-1. These address output lines are multiplexed with the DRAM row and column address signals. The MD signal is selected on DRAM access cycles.

2.6 BUS CONTROL SIGNALS

- **$\overline{\text{LWE}}$, $\overline{\text{UWE}}$** —Lower Byte Write-Enable and Upper Byte Write-Enable. On a write cycle to a 16-bit port, these active-low output signals indicate when the upper or lower eight bits of the data bus contain valid data. In 8-bit mode or when the BSW bit in the chip-select register is 0, use only the $\overline{\text{UWE}}$ signal for write-enable control. $\overline{\text{UWE}}$ can be used as a DRAM write enable if DRAM refresh does not require that $\overline{\text{UWE}}$ stay high. Otherwise, $\overline{\text{DWE}}$ should be used.
- **$\overline{\text{DWE}}$ / $\overline{\text{UCLK}}$ / $\overline{\text{PE3}}$** —DRAM Write-Enable, UART Clock, and Port E Bit 3. Use the $\overline{\text{DWE}}$ signal with DRAM, which requires an independent write-enable signal, rather than one that is shared with $\overline{\text{UWE}}$. This signal stays high during refresh cycles. This pin defaults to a PE3 input signal. To select the $\overline{\text{DWE}}$ function, program Port E to $\overline{\text{DWE}}$ and enable the $\overline{\text{DWE}}$ signal by writing a 1 to the DWE bit of the DRAMC register, which is described in [Section 14.2.2 DRAM Control Register](#). If this bit is not enabled, the UCLK signal function is selected, which is an input clock to the UART module. For a description of UCLK, refer to .
- **$\overline{\text{BUSW}}$ / $\overline{\text{DTACK}}$ / $\overline{\text{PG0}}$** —Bus Width, Data Transfer Acknowledge, Port G Bit 0. The $\overline{\text{BUSW}}$ signal is the default bus width for the $\overline{\text{CSA0}}$ signal. The $\overline{\text{DTACK}}$ signal is the external input data acknowledge signal. The MC68EZ328 microprocessor will latch this signal at the rising edge of the $\overline{\text{RESET}}$ signal. Its mode will determine the default bus width for $\overline{\text{CSA0}}$. For example, a logic low of $\overline{\text{BUSW}}$ on reset means that $\overline{\text{CSA0}}$ connects to an 8-bit memory device and a logic high of $\overline{\text{BUSW}}$ on reset means that $\overline{\text{CSA0}}$ connects to a 16-bit memory device. After reset, this pin defaults to the $\overline{\text{DTACK}}$ signal. It can be configured as a $\overline{\text{DTACK}}$ function by programming the PGSEL register, which is described in [Section 7.2.7 Port G Registers](#). To generate a $\overline{\text{DTACK}}$ signal, refer to [Section 14.1.2 DTACK Generation](#). When external DTACK function is used to terminate CPU cycles, an external 1K ohm pull-up resistor on this signal is required. The 1K ohm pull-up resistor is not required when the system uses the internal DTACK for all chip select signals.
- **$\overline{\text{OE}}$** —Output Enable. This active-low signal is asserted during a read cycle of the MC68EZ328 microprocessor, which enables the output of either ROM or SRAM.

2.7 INTERRUPT CONTROLLER SIGNALS

- **$\overline{\text{INT}}[3:0]$, $\overline{\text{IRQ}}[3:1]$, $\overline{\text{IRQ6/PD}}[7:0]$** —Interrupt Bits 3-0, Interrupt Request Bits 3-1, and Port D Bits 7-0. You can program these signals as interrupt inputs or parallel I/O ports. When these signals are programmed to function as interrupts, they are schmitt trigger inputs. To support keyboard applications, the I/O function can be used with interrupt capabilities, which are described in [Section 6.1 Interrupt Processing](#). The pin defaults to a PDx input signal.
- **$\overline{\text{IRQ5/PF1}}$** —Interrupt Request 5 and Port F Bit 1. This signal can be programmed to either a parallel I/O or a schmitt trigger interrupt input. When it is configured as an interrupt input it can be programmed as a level high or level low trigger interrupt.

2.8 LCD CONTROLLER SIGNALS

- **LD[3:0]/PC[3:0]**—LCD Data Bus Bits 3-0 and Port C Bits 3-0. This output bus transfers pixel data to the LCD panel that it will be displayed on. The pixel data is arranged to accommodate the programmable panel mode data width selection. Panel interfaces of one, two, or four bits are supported. You can also program the output pixel data to be inverted if it is required by your LCD panel.

The MC68EZ328's LCD interface data bus uses LD0 to display pixel 0, 0. Some LCD panel manufacturers program their LCD panel data bus so that data bit 3 of the panel displays pixel 0,0. For these panels, the connection between the MC68EZ328's LCD data bus and the LCD panel's data bus could have a reversed bit significance. For these panels, you must connect the MC68EZ328's LD0 signal to the LCD panel's data bit 3, then connect LD1 to LCD data 2, LD2 to LCD data 1, and LD3 to LCD data 0. The four pins can also be programmed as I/O ports from Port C. This pin defaults to a PCx input signal pulled low.

- **LFLM/PC4**—First Line Marker and Port C Bit 4. This signal indicates the start of a new display frame. LFLM becomes active after the first line pulse of the frame and remains active until the next line pulse, at which point it deasserts and remains inactive until the next frame. LFLM can be programmed to be an active-high or an active-low signal. It can also be programmed as an I/O port.
- **LLP/PC5**—LCD Line Pulse and Port C Bit 5. This signal latches a line of shifted data onto the LCD panel. It becomes active when a line of pixel data is clocked into the LCD panel and remains asserted for eight pixel clock periods. LLP can be programmed to be either an active-high or active-low signal. This pin can also be programmed as an I/O port.
- **LCLK/PC6**—LCD Shift Clock and Port C Bit 6. This is the clock output to which the output data to the LCD panel is synchronized. LCLK can be programmed to be either an active-high or an active-low signal. This pin can also be programmed as an I/O port.
- **LACD/PC7**—LCD Alternate Crystal Direction and Port C Bit 7. This output is toggled to alternate the crystal polarization on the panel. This signal can be programmed to toggle at a period of 1 to 16 frames. This pin also can also be programmed as an I/O port.
- **LCONTRAST/PF0**—LCD Contrast and Port F Bit 0. This output controls the pulse-width modulator (PWM) inside the LCD controller to adjust the supply voltage to the LCD panel. This pin can also be programmed as an I/O port. This pin defaults to a PFx input signal pulled high.

2.9 UART CONTROLLER SIGNALS

- **RXD/PE4**—UART Receive Data and Port E Bit 4. This pin is the receiver serial input. During normal operation, NRZ data is expected, but in infra-red mode, a narrow pulse is expected for each zero bit received. External circuitry must be used to convert the infra-red signal to an electrical signal. RS-232 applications need an external RS-232 receiver to convert voltage levels. This pin defaults to a general-purpose PE4 input signal.
- **TXD/PE5**—UART Transmit Data and Port E Bit 5. This pin is the transmitter serial output. During normal operation, NRZ data is output, but in infra-red mode, a 3/16 bit-period pulse is output for each “zero” bit transmitted. For RS-232 applications, this pin must be connected to an RS-232 transmitter. For infra-red applications, this pin can directly drive an infra-red LED. This pin defaults to a general-purpose PE5 input signal.
- **RTS/PE6**—Request to Send and Port E Bit 6. This pin serves two purposes. Normally, the receiver indicates that it is ready to receive data by asserting this pin (low). This pin would be connected to the far-end transmitter’s $\overline{\text{CTS}}$ pin. When the receiver detects a pending overrun, it negates this pin. For other applications, this pin can be a general-purpose output controlled by a bit in the URX register, which is described in [Section 11.3.3 UART Receiver Register](#). When it is programmed as parallel I/O, it becomes PE6. This pin defaults to a general-purpose PE6 input signal.
- **CTS/PE7**—Clear to Send and Port E Bit 7. This input controls the transmitter. Normally, the transmitter waits until this signal is active (low) before a character is transmitted. If the NOCTS bit is set in the UTX register, the transmitter sends a character whenever a character is ready to transmit. See [Section 11.3.4 UART Transmitter Register](#) for more information. This pin can then be used as a general-purpose input whose status is read in the CTSSTAT bit of the UTX register. This pin can post an interrupt on any transition of $\overline{\text{CTS}}$, if enabled. This pin defaults to a $\overline{\text{CTS}}$ signal.

2.10 TIMER SIGNAL

- **TOUT/TIN/PB6**—Timer Output, Timer Input, and Port B Bit 6. This bidirectional signal can be programmed to toggle or generate a pulse of one system clock duration when timer/counter reaches a reference value. After reset, this pin defaults to a general-purpose input PB6 signal.

2.11 PULSE-WIDTH MODULATOR SIGNAL

- **PWMO/PB7**—Pulse Width Modulator Output and Port B Bit 7. This pin can serve as the PWM output signal. When it is PWMO, it produces synthesized sound, which can be connected to an audio amplifier and filter to generate melody and tone. This pin defaults to a general-purpose PB7 input signal.

2.12 SERIAL PERIPHERAL INTERFACE SIGNALS

- **SPMTXD/PE0**—SPI Master Transmit Data and Port E Bit 0. This pin is the master SPI shift register output signal. This pin defaults to a general-purpose PE0 input signal.
- **SPMRXD/PE1**—SPI Master Receive Data and Port E Bit 1. This pin is the input to the master SPI shift register. This pin defaults to a general-purpose PE1 input signal.

- **SPMCLK/PE2**—SPI Master Clock and Port E Bit 2. This pin is the clock output when the serial peripheral interface master is enabled. In polarity = 0 mode, this signal is low while the serial peripheral interface master is idle. In polarity = 1 mode, this signal is high during idle. This pin defaults to a general-purpose PE2 input signal.

2.13 CHIP-SELECT SIGNALS

- **$\overline{\text{CSA0}}$** —Chip-Select A Bit 0. $\overline{\text{CSA0}}$ is a default chip-select signal after reset. It is set to six wait-states and decodes all address ranges, except internal register address space and emulator space (0xFFFC0000-0xFFDFFFFF). It can be reprogrammed during the boot sequence to another address range or different wait-states. The default data bus width for $\overline{\text{CSA0}}$ is determined by the state of the BUSW signal.
- **$\overline{\text{CSA1/PF7}}$, $\overline{\text{CSB[1:0]/PB[1:0]}$, $\overline{\text{CSC[1:0]/PB[3:2]}$, $\overline{\text{CSD[1:0]/PB[5:4]}$** —Chip-Select A, B, C, and D Bits 0 and 1, Port F Bit 7, Port B Bits 5-0. These pins comprise the remainder of the Group A, B, C, and D chip-selects and are individually programmable. Pins that are not needed as chip-selects can be programmed as general-purpose I/Os. In addition, $\overline{\text{CSC[1:0]}}$ and $\overline{\text{CSD[1:0]}}$ are designed to support DRAM as $\overline{\text{CAS}}$ and $\overline{\text{RAS}}$ signals. These pins default to a general-purpose input signal.

2.14 IN-CIRCUIT EMULATION SIGNALS

- **$\overline{\text{HIZ/P/D/PG3}}$** —High Impedance, Program/Data, and Port G Bit 3. During system reset, a logic low of this input signal will put the MC68EZ328 into Hi-Z mode, in which all MC68EZ328 pins are three-stated after reset release. For normal operation, this pin must be pulled high during system reset or left unconnected. This pin defaults to the P/ $\overline{\text{D}}$ function, but can be programmed as a general-purpose I/O. P/ $\overline{\text{D}}$ is a status signal that shows whether the current bus cycle is in program space or in data space during emulation mode.
- **$\overline{\text{EMUIRQ/PG2}}$** —Emulator Interrupt Request and Port G Bit 2. During system reset, a logic low of this input signal will put the MC68EZ328 into emulation mode, which is described in . For normal operation, this pin must be pulled high during system reset or left unconnected. After system reset this pin defaults to an $\overline{\text{EMUIRQ}}$ function in normal or emulation mode. $\overline{\text{EMUIRQ}}$ is an active low, level 7 interrupt input signal.
- **$\overline{\text{EMUBRK/PG5}}$** —Emulator Breakpoint and Port G Bit 5. During system reset, a logic low of this input signal will put the MC68EZ328 into bootstrap mode, which is described in . For normal operation, this pin must be pulled high during system reset or left unconnected. After system reset, this pin defaults to the $\overline{\text{EMUBRK}}$ function, which is an I/O signal used in emulation mode for breakpoint control.
- **$\overline{\text{EMUCS/PG4}}$** —Emulator Chip-Select and Port G Bit 4. $\overline{\text{EMUCS}}$ is an 8-bit data bus width chip-select signal that selects the dedicated memory space from 0xFFFC0000 to 0xFFDFFFFF. It cannot be used to select 16-bit data bus memory devices. $\overline{\text{EMUCS}}$ is not only activated in emulation mode, but in normal and bootstrap modes as well. See for more information about $\overline{\text{EMUCS}}$ operation. This pin defaults to an $\overline{\text{EMUCS}}$ signal.

SECTION 3 SYSTEM CONTROL

The MC68EZ328 microprocessor contains a system control register that enables the system software to customize the following functions:

- Access permission from the internal peripheral registers
- Address space of the internal peripheral registers
- Bus time-out control and status (bus-error generator)

3.1 OPERATION

The on-chip resources use a reserved 4,096-byte block of address space for their registers. This block is double-mapped to two locations at reset—0xFFFFF000 (32-bit) and 0xFFF000 (24-bit). The DMAP bit in the system control register disables double-mapping in a 32-bit system. If you clear this bit, the on-chip peripheral registers appear only at the top of the 4G address range starting at 0xFFFFF000.

The system control register allows you to control system operation functions like bus interface and hardware watchdog protection. It contains status bits that allow exception handler code to investigate the cause of exceptions and resets. The hardware watchdog (bus time-out monitor) and the software watchdog timer provide system protection. The hardware watchdog provides a bus monitor that causes a bus error when a bus cycle is not terminated by the \overline{DTACK} signal before 128 clock cycles have elapsed.

The bus error time-out logic consists of a watchdog counter that, when enabled, begins to count clock cycles as the internal \overline{AS} pin is asserted for internal or external bus accesses. The negation of \overline{AS} normally terminates the count, but if the count reaches terminal count before \overline{AS} is negated, \overline{BERR} is asserted until \overline{AS} is negated. The bus error time-out logic uses one control bit and one status bit in the system control register. The BETO bit in the system control register is set after a bus time-out, which could be caused by a write-protect violation.

The software watchdog timer resets the MC68EZ328 if enabled and not cleared or disabled before reaching terminal count. The software watchdog timer is enabled at reset.

3.2 PROGRAMMING MODEL

3.2.1 System Control Register

The 8-bit read/write system control register (SCR) resides at 0xFFFFF000 after reset. The SCR cannot be accessed in user data space if the SO bit is set to 1. Writing a 1 to the status bits in this register clears them, but writing a 0 has no effect.

SCR

BIT	7	6	5	4	3	2	1	0
FIELD	BETO	WPV	PRV	BETEN	SO	DMAP	RESERVED	WDTH8
RESET	0x1C							
ADDR	0x(FF)FFF000							

BETO—Bus Error Time-Out

This status bit indicates whether or not a bus error timer time-out has occurred. When a bus cycle is not terminated by the \overline{DTACK} signal after 128 clock cycles have elapsed, the BETO bit is set. However, the BETEN bit must be set for a bus error time-out to occur. This bit is cleared by writing a 1 (writing a 0 has no effect).

0 = A bus error timer time-out did not occur.

1 = A bus error timer time-out occurs because an undecoded address space has been accessed or because a write-protect or privilege violation has occurred.

WPV—Write-Protect Violation

This status bit indicates that a write-protect violation has occurred. If a write-protect violation occurs and the BETEN bit is not set, the cycle will not terminate. The BETEN bit must be set for a bus error exception to occur during a write-protect violation. This bit is cleared by writing a 1 (writing a 0 has no effect).

0 = A write-protect violation did not occur.

1 = A write-protect violation has occurred.

PRV—Privilege Violation

This status bit indicates that If a privilege violation occurs and the BETEN bit is not set, the cycle will not terminate. The BETEN bit must be set for a bus error exception to occur during a privilege violation. This bit is cleared by writing a 1 (writing a 0 has no effect).

0 = A privilege violation did not occur.

1 = A privilege violation has occurred.

BETEN—Bus-Error Time-Out Enable

This control bit enables the bus error timer.

0 = Disable the bus error timer.

1 = Enable the bus error timer.

SO—Supervisor Only

This control bit limits on-chip registers to supervisor accesses only.

0 = User and supervisor mode.

1 = Supervisor-only mode.

DMAP—Double Map

This control bit controls the double-mapping function.

0 = The on-chip registers are mapped at 0xFFFFF000–0xFFFFFFFF.

1 = The on-chip registers are mapped at 0xFFFFF000–0xFFFFFFFF and 0xFFF000–0xFFFF.

Bit 1—Reserved

This bit is reserved and reads 0.

WDTH8—8-Bit Width Select

This control bit allows the D[7:0] pins to be used for port B input/output.

0 = Not an 8-bit system.

1 = 8-bit system.



SECTION 4 CHIP-SELECT LOGIC

The MC68EZ328 microprocessor contains eight general-purpose, programmable, chip-select signals, which are arranged in four groups of two—($\overline{CSA}[1:0]$, $\overline{CSB}[1:0]$, $\overline{CSC}[1:0]$, $\overline{CSD}[1:0]$). Among them is a special-purpose chip-select signal— $\overline{CSA0}$ —which is also a boot device chip-select. From reset, all the addresses are mapped to $\overline{CSA0}$ until group base address A is programmed and the EN bit is set in the appropriate chip-select register. From that point on, $\overline{CSA0}$ does not decode globally and it is only asserted when decoded from the programming information in the chip-select register. Group C ($\overline{CSC0}/\overline{CSC1}$) and Group D ($\overline{CSD0}/\overline{CSD1}$) chip-selects are also special because they can be programmed as row address strobe ($\overline{RAS0}/\overline{RAS1}$) and column address strobe ($\overline{CAS0}/\overline{CAS1}$) for DRAM interface. For details, refer to and the chip-select group C and D registers. For each memory area, you can define an internally generated cycle-termination signal, called \overline{DTACK} , with a programmable number of wait states. This feature saves board space that would otherwise be used for cycle-termination logic.

With the mentioned chip-selects, the system can adopt flexible memory configuration based on cost and availability. Up to four different classes of devices/memory can be used in a system without external decode or wait-state generation logic. Specifically, 8- or 16-bit combinations of ROM, SRAM, Flash memory, and DRAM are supported, as shown in Figure 4-1.

$\overline{CSA0}$	ROM, SRAM, FLASH MEMORY CHIP-SELECT
$\overline{CSA1}$	ROM, SRAM, FLASH MEMORY CHIP-SELECT
$\overline{CSB0}$	ROM, SRAM, FLASH MEMORY CHIP-SELECT
$\overline{CSB1}$	ROM, SRAM, FLASH MEMORY CHIP-SELECT
$\overline{CSC0}/\overline{RAS0}$	DRAM, ROM, SRAM, FLASH MEMORY CHIP-SELECT
$\overline{CSC1}/\overline{RAS1}$	DRAM, ROM, SRAM, FLASH MEMORY CHIP-SELECT
$\overline{CSD0}/\overline{CAS0}$	DRAM, ROM, SRAM, FLASH MEMORY CHIP-SELECT
$\overline{CSD1}/\overline{CAS1}$	DRAM, ROM, SRAM, FLASH MEMORY CHIP-SELECT

Figure 4-1. Chip-Selects and Memory Types

The basic chip-select model allows the chip-select output signal to assert in response to an address match. The signals are asserted externally shortly after the internal \overline{AS} signal goes low. The address match is described in terms of a group base address register and a

chip-select register. The memory size of the chip-select can be selected from a set of predefined ranges (32K, 64K, 128K, 256K, 512K, 1M, 2M, and 4M). These memory ranges represent the most popular memory sizes available on the market and apply to \overline{CSBx} , \overline{CSCx} , and \overline{CSDx} . For $\overline{CSA0}$, since it mainly supports ROM, which is usually 128K to 16M. With this scheme, you can easily design software without dealing with the chip-select mask register. You can choose whether the chip-select allows read-only or read/write accesses, whether a \overline{DTACK} signal is automatically generated for the chip-select, the number of wait states (from zero to six), and data bus size selection.

4.1 CHIP-SELECT OPERATION

A chip-select output signal is asserted when an address is matched and after the \overline{AS} signal goes low. The base address and address mask registers are used in the compare logic to generate an address match. The byte size of the matching block must be a power of two and the base address must be an integer multiple of this size. Therefore, an 8K block size must begin on an 8K boundary and a 64K block size can only begin on a 64K boundary. Each chip-select is programmable and the registers have read/write capability so that the programmed values can be read back.



Note: The chip-select logic does not allow an address match during interrupt acknowledge (Function Code 7) cycles.

4.1.1 Memory Protection

The chip-select range of the four chip-selects can be programmed as read-only or read/write. For chip-selects that control the crucial system data, they are usually programmed as supervisor-only and read-only so it can be protected from system misuse (e.g. low battery). However, a certain area of this chip-select controlled area can be programmed as read/write, which provides optimal memory use, as shown in Figure 4-2. This area can be defined by programming the UPSIZ bits in the CSB, CSC, and CSD registers to between 32K and 256K.

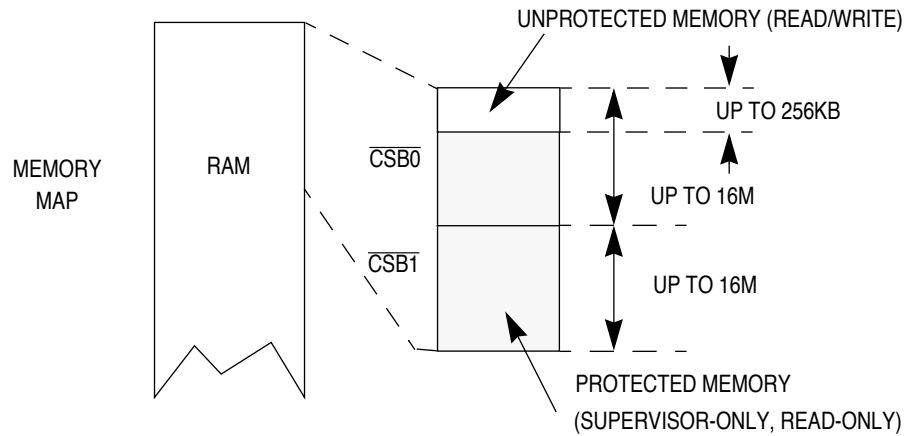

Figure 4-2. Size Selection and Memory Protection for CSB0 and CSB1

4.1.2 Programmable Data Bus Size

Each chip-select can be configured to address an 8- or 16-bit space. You can mix 16- and 8-bit contiguous address memory devices on a 16-bit data bus system. If the core performs a 16-bit data transfer in an 8-bit memory space, then two 8-bit cycles will occur. However, the address and data strobes remain asserted until the end of the second 8-bit cycle. In this case, only the external core data bus upper byte (D[15:8]) is used and the least-significant bit of the address (A0) increments automatically from one to the next. A0 should be ignored in 16-bit data-bus cycles even if only the upper or lower byte is being read or written. For an external peripheral that only needs an 8-bit data bus interface and does not require contiguous address locations (unused bytes on empty addresses), use a chip-select configured to a 16-bit data bus width and connect to the D[7:0] pins. This balances the load of the two data bus halves in an 8-bit system. The internal data bus is 16 bits wide. All internal registers can be read or written in a zero wait-state cycle.

Each chip-select defaults to a 16-bit data bus width. The BSW field of the chip-select option register enables 16- and 8-bit data bus widths for each of the 16 chip-select ranges. You can select the initial bus width for the boot chip-select by placing a logic 0 or 1 on the BUSW pin at reset to specify the width of the data bus. This allows a boot EPROM of the data bus width to be used in any given system. All external accesses that do not match one of the chip-select address ranges are assumed to be a 16-bit device. That is just one access performed for a 16-bit transfer. It can also be a 8-bit port accessed every other byte.

The boot chip-select is initialized from reset to assert in response to any address except the on-chip register space (0xFFFFF000 to 0xFFFFFFFF). This ensures that a chip-select to the boot ROM or EPROM will fetch the reset vector and execute the initialization code, which should set up the chip-select ranges.

A logic 0 on the BUSW pin sets the boot device's data bus to 8 bits wide and a logic 1 sets it to 16 bits wide. At reset, the data bus port size for $\overline{CSA0}$ and the data width of the boot ROM device are determined by the state of BUSW. The other chip-selects are initialized to

be nonvalid, so they will not assert until they are programmed and the EN bit is set in the chip-select registers.



Note: If the group address and chip-select registers are programmed to overlap, the chip-select signals will overlap too. Unused chip-selects must be programmed to 0 wait-states and 16 bits wide. Map them to dummy space if necessary. When you are configuring the chip-select signals, the core can be set to write to a read-only location. This prevents the chip-select and \overline{DTACK} signals from not being asserted, but the internal \overline{BERR} signal to be asserted, if a bus error timer is enabled.

4.1.3 Overlapping Chip-Select Registers

You should not program the group address and chip-select registers to overlap. If you do, the chip-select signals will overlap. Unused chip-selects must be disabled. Map them to an unused space, if possible.

When the CPU tries to write to a read-only location that you have programmed, the chip-select and \overline{DTACK} signals will not be generated internally. \overline{BERR} will be asserted internally if the bus error time-out function is enabled.



Note: The chip-select logic does not allow an address match during interrupt acknowledge cycles.

4.2 PROGRAMMING MODEL

The chip-select module contains registers that you can use to control external devices, such as memory. Chip-selects do not operate until the register in a particular group of devices is initialized and the EN bit is set in the corresponding chip-select register. The only exception is the $\overline{CSA0}$ signal, which is the boot device chip-select.

4.2.1 Chip-Select Group Base Address Registers

There are four 16-bit chip-select group base address A-D (CSGBA-CSGBD) registers in the chip-select module (one for each chip-select group). These registers define the address at which the chip-select starts. For example, the $\overline{CSA0}$ signal can start at 0x000000 if you program the CSGBA register and $\overline{CSA1}$ returns the selected memory size apart from $\overline{CSA0}$.

CSGBA-CSGBD

BIT	15	14	13	12	11	10	9	8	7	6	5	4	3	2	1	0
FIELD	GBA28	GBA27	GBA26	GBA25	GBA24	GBA23	GBA22	GBA21	GBA20	GBA19	GBA18	GBA17	GBA16	GBA15	GBA14	—
RESET	0x0000															
ADDR	0x(FF)FFF100, 102, 104, 106															

GBAx—Group Base Address 28–14

This field (the upper 15 bits of each base address register) selects the starting address for the chip-select address range. The GBAx field is compared to the address on the address bus to determine if the group is decoded. The chip-select base address must be set according to the size of the corresponding chip-select signals of the group. For example, if $\overline{CSA1}$ and $\overline{CSA0}$ are each assigned a 2M memory space, the CSGBA register must be set in a 4M space boundary, such as system address 0x0, 0x4M, 0x8M and so on. It cannot be set at 0x1M, 0x2M, 0x3M, 0x5M, etc.

Bit 0—Reserved

This bit is reserved and should be set to 0.

4.2.2 Chip-Select Registers

There are four 16-bit chip-select (CSA, CSB, CSC, and CSD) registers for each corresponding chip-select base address register. Each of these registers controls two chip-select signals and can be configured to select the memory type, size of the memory range supported, and to program the required wait-states or use the external \overline{DTACK} signal.

CSA

BIT	15	14	13	12	11	10	9	8	7	6	5	4	3	2	1	0
FIELD	RO	—						FLASH	BSW	WS2	WS1	WS0	SIZ2	SIZ1	SIZ0	EN
RESET	0x0000															
ADDR	0x(FF)FFF110															

CSB AND CSC

BIT	15	14	13	12	11	10	9	8	7	6	5	4	3	2	1	0
FIELD	RO	SOP	ROP	UPSIZ ₁	UPSIZ ₀	—		FLASH	BSW	WS2	WS1	WS0	SIZ2	SIZ1	SIZ0	EN
RESET	0x0000															
ADDR	0x(FF)FFF112 AND 0x114															

CSD

BIT	15	14	13	12	11	10	9	8	7	6	5	4	3	2	1	0
FIELD	RO	SOP	ROP	UPSIZ ₁	UPSIZ ₀	COMB	DRAM	FLASH	BSW	WS2	WS1	WS0	SIZ2	SIZ1	SIZ0	EN
RESET	0x0200															
ADDR	0x(FF)FFF116															

Chip-Select Logic

RO—Read Only

This bit sets the chip-select to read-only. Otherwise, read and write accesses are allowed. A write to a read-only area will generate a bus error if the BETEN bit of the SCR is set. See [Section 3.2.1 System Control Register](#) for more information.

- 0 = Read/write.
- 1 = Read-only.

SOP—Supervisor-Only for Protected Memory Block

This bit sets the protected memory block to supervisor-only. Otherwise, supervisor and user accesses are allowed. If you access the supervisor-only area, you will get a bus error if the BETEN bit of the SCR is set. See [Section 3.2.1 System Control Register](#) for more information.

- 0 = Supervisor/user.
- 1 = Supervisor-only.

ROP—Read-Only for Protected Memory Block

This bit sets the protected memory block to read-only. Otherwise, read and write accesses are allowed. If you write to a read-only area, you will get a bus error.

- 0 = Read/write.
- 1 = Read-only.

UPSIZ—Unprotected Memory Block Size

This field determines the unprotected memory range of the chip-select.

- 00 = 32K.
- 01 = 64K.
- 10 = 128K.
- 11 = 256K.

COMB—Combining

This bit controls combining $\overline{RAS0}$ and $\overline{RAS1}$ memory space to generate $\overline{RAS0}$. When this bit is set to 1, $\overline{RAS1}$ can be used as a general-purpose I/O signal.

- 0 = $\overline{RAS0}$ to $\overline{RAS0}$ memory space.
- 1 = $\overline{RAS0}$ covers both $\overline{RAS0}$ and $\overline{RAS1}$ memory space B.

DRAM—DRAM Selection

This bit is used to select the $\overline{\text{RAS}}$ and $\overline{\text{CAS}}$ signals.

- 0 = Select $\overline{\text{CSC}}[1:0]$ and $\overline{\text{CSD}}[1:0]$.
- 1 = Select $\overline{\text{CAS}}$ and $\overline{\text{RAS}}$.



Note: To configure the CSC register as a non-DRAM memory type, you must clear the DRAM bit of the CSD register.

FLASH—Flash Memory Support

To support Flash memory, this bit forces the $\overline{\text{LWE}}/\overline{\text{UWE}}$ signal to go active after chip-select.

- 0 = The chip-select and $\overline{\text{LWE}}/\overline{\text{UWE}}$ signals go active at the same clock edge.
- 1 = The chip-select signal goes low one clock before $\overline{\text{LWE}}/\overline{\text{UWE}}$.

BSW—Data Bus Width

This bit sets the data bus width for this chip-select area.

- 0 = 8-bit.
- 1 = 16-bit.

WS—Wait-State

This field determines the number of wait-states added before an internal $\overline{\text{DTACK}}$ signal is returned for this chip-select.

- 000 = Zero wait states.
- 001 = One wait state.
- 010 = Two wait states.
- 011 = Three wait states.
- 100 = Four wait states.
- 101 = Five wait states.
- 110 = Six wait states.
- 111 = External $\overline{\text{DTACK}}$.



Note: When using the external $\overline{\text{DTACK}}$ signal, you must configure the BUSW/DTACK/PG0 pin.

Chip-Select Logic

SIZ—Chip-Select Size

This field determines the memory range of the chip-select. For \overline{CSA}_x and \overline{CSB}_x , the chip-select size is between 128K and 16M. For \overline{CSC}_x and \overline{CSD}_x , the chip-select size is between 32K and 4M.

- 000 = 128K (32K for \overline{CSC}_x and \overline{CSD}_x).
- 001 = 256K (64K for \overline{CSC}_x and \overline{CSD}_x).
- 010 = 512K (128K for \overline{CSC}_x and \overline{CSD}_x).
- 011 = 1M (256K for \overline{CSC}_x and \overline{CSD}_x).
- 100 = 2M (512K for \overline{CSC}_x and \overline{CSD}_x).
- 101 = 4M (1M for \overline{CSC}_x and \overline{CSD}_x).
- 110 = 8M (2M for \overline{CSC}_x and \overline{CSD}_x).
- 111 = 16M (4M for \overline{CSC}_x and \overline{CSD}_x).

EN—Chip-Select Enable

This write-only bit enables each chip-select.

- 0 = Disabled.
- 1 = Enabled.

4.2.3 Emulation Chip-Select Register

In addition to the eight general-purpose chip-select signals, the MC68EZ328 has an emulation chip-select register (EMUCS) that is specifically designed for the in-circuit emulation module. This register only provides wait-states 6-0, depending on the type of chip you are using. You can also use the external logic (\overline{DTACK}) to have longer wait-states. EMUCS is only valid for the 0xFFFC0000-0xFFFDFFFF memory location.

EMUCS

BIT	15	14	13	12	11	10	9	8	7	6	5	4	3	2	1	0
FIELD	-									WS2	WS1	WS0	-			
RESET	0x0060															
ADDR	0x(FF)FFF118															

WS—Wait-State 2–0

This field determines the number of wait states added before an internal $\overline{\text{DTACK}}$ is returned for this chip-select.

000 = Zero wait states.
 001 = One wait state.
 010 = Two wait states.
 011 = Three wait states.
 100 = Four wait states.
 101 = Five wait states.
 110 = Six wait states.
 111 = External $\overline{\text{DTACK}}$.



Note: When using the external $\overline{\text{DTACK}}$ signal, you must configure the BUSW/ $\overline{\text{DTACK}}$ /PG0 pin.

4.3 PROGRAMMING EXAMPLE

This following fragment of software code demonstrates how to initialize the chip-select with a particular memory configuration.

```
*****
*   Chip-Select registers
*****
REGSBASE   equ    0xFFFFF000      internal registers base address
BASEA     equ    REGSBASE+0x100    group A base register
BASEB     equ    REGSBASE+0x102    group B base register
BASEC     equ    REGSBASE+0x104    group C base register
BASED     equ    REGSBASE+0x106    group D base register
CSA       equ    REGSBASE+0x110    group A chip select register
CSB       equ    REGSBASE+0x112    group B chip select register
CSC       equ    REGSBASE+0x114    group C chip select register
CSD       equ    REGSBASE+0x116    group D chip select register
*****
*   PORT control registers
*****
PORTBASE   equ    REGSBASE+0x400    port B registers base address
PBDir      equ    PORTBASE+0x08     port B direction register
PBData     equ    PORTBASE+0x09     port B data register
PBPU       equ    PORTBASE+0x0A     port B pullup enable register
PBSEL      equ    PORTBASE+0x0B     port B select register

*****
*   Initialization
*****
START      move.b   #0x00,PBSEL      disable PortB, select chip selects

          move.w   #0x0000,BASEA     set base address 0x0000000
          move.w   #0x8081,CSA       read-only,16-bit,0 wait-state,128K

          move.w   #0x2000,BASEB     set base address 0x4000000
```

Freescale Semiconductor, Inc.

Chip-Select Logic

```
move.w    #0x0093,CSB        read/write,16-bit,1 wait-state,256K

move.w    #0x2040,BASEC      set base addr 0x4080000
move.w    #0x0191,CSC        read/write,flash,16-bit,1 ws,32K

move.w    #0x0000,CSD        config CSC,CSD as non-DRAM memory type
```

* The above initialization will configurate the CSA and CSB chip selects as
* follows :

```
*
*   CSA0 0x0000000-0x001ffff,read-only, 16-bit,0 wait-state,128K
*   CSA1 0x0020000-0x003ffff,read-only, 16-bit,0 wait-state,128K
*   CSB0 0x4000000-0x403ffff,read/write,16-bit,1 wait-state,256K
*   CSB1 0x4040000-0x407ffff,read/write,16-bit,1 wait-state,256K
*   CSC0 0x4080000-0x4087fff,read/write,flash,16-bit,1 wait-state, 32K
*   CSC1 0x4088000-0x408ffff,read/write,flash,16-bit,1 wait-state, 32K
*   CSD0 disabled
*   CSD1 disabled
```

SECTION 5 PHASE-LOCKED LOOP AND POWER CONTROL

The phase-locked-loop (PLL) generates all of the clocks for the MC68EZ328 microprocessor. It includes a crystal oscillator that can be used with low-frequency crystals. The PLL generates a high-frequency master clock that is phase-locked to the crystal reference. The features of the PLL are:

- Fully static HCMOS technology
- Programmable clock synthesizer using a 32.768kHz or 38.4kHz crystal for full frequency control
- Low-power stop capabilities
- Modules can be individually shut down
- Lowest power mode control

The PLL is a flexible clock source for the MC68EZ328. It provides a crystal-controlled master clock at 32kHz frequencies that are no lower than 13MHz. The master clock can be divided down to provide a system clock as low as a sixteenth of the voltage-controlled oscillator (VCO) frequency. The low-frequency reference clock (32.768kHz or 38.4kHz) is always available to the real-time clock or timer. The PLL can be disabled to save power, but it can be reenabled within 1ms of a wakeup interrupt. The PLL, used in conjunction with the power control block, provides an efficient power-control mechanism for the MC68EZ328 microprocessor, as illustrated in Figure 5-1.

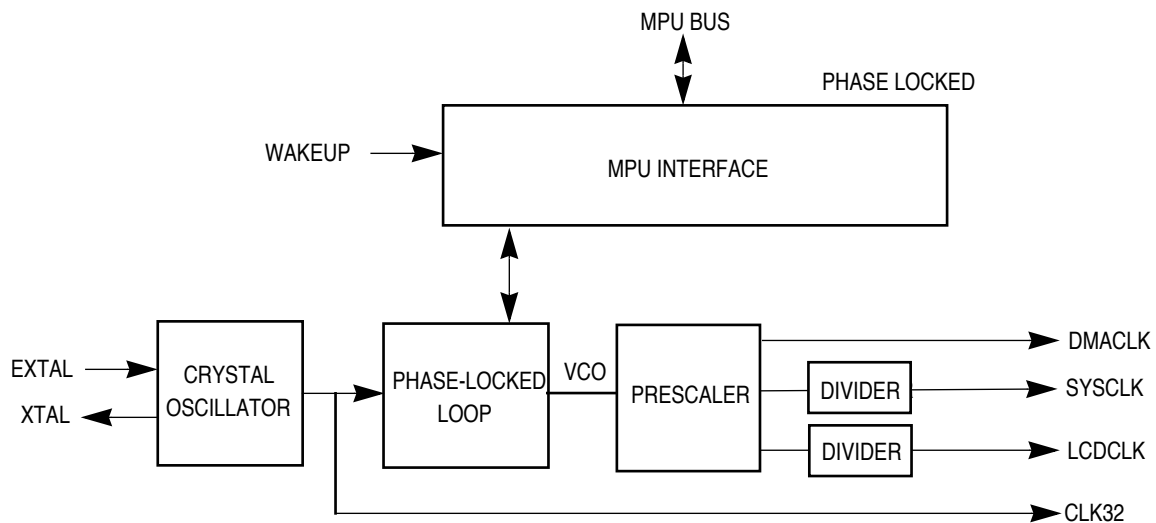

Figure 5-1. PLL Block Diagram

5.1 OPERATION

5.1.1 Using the PLL To Reduce Power Consumption

The PLL uses a dual-modulus prescaler to reduce power consumption. This approach divides the VCO frequency by 14 before it is fed to the rest of the divider chain.

Dual-modulus counters operate differently from other counters in that the overall divide ratio depends on two separate values—P and Q. Besides the power-saving advantage, above a divisor of 397 (decimal), every divisor is available to fine-tune the VCO in 32kHz steps. The formula for the dual-modulus divider is:

$$\text{Divisor} = 14 (P + 1) + Q + 1$$

where

$$1 \leq Q \leq 14$$

$$P \geq Q + 1$$

The minimum divisor is P=0x1B, Q=0x04 (397 decimal). This produces 13.008896MHz.

5.1.2 PLL Operation at Power-Up

At initial power-up, the crystal oscillator begins oscillating within several hundred milliseconds. While reset remains asserted, the PLL begins the lockup sequence and locks 1ms before the crystal oscillator becomes stable. Once lockup occurs, the VCO frequency is 16.580608 MHz, assuming that a 32.768 kHz crystal is used. When using a 38.400 kHz crystal the VCO frequency is 19.430400MHz. The system clock is reset to VCO divided by 2 as a result of the default setting of the PRESC bit in the LL control register. The boot sequence must change the VCO frequency to less than 16.7MHz and clear the PRESC bit before activating any modules or changing the chip-select wait-state settings.

To generate the master frequency, multiply the reference (32.768kHz) by the PLL divisor. The default divisor is 506. The divisor can be changed under software control, which is described in [Section 5.1.4 Changing the VCO Frequency](#).



Note: The default divider value (506) was selected because it can directly generate standard baud frequencies at a better than 0.1% accuracy rate.

5.1.3 PLL Operation at Wake-Up

When the MC68EZ328 is awakened from sleep mode by a wake-up event, the PLL achieves lock within 1ms. The crystal oscillator is always on after initial power-up, so the crystal startup time is not a factor. The master clock starts operating once the PLL achieves lock.

5.1.4 Changing the VCO Frequency

To change the VCO frequency, you should use the sequence below. It assumes all peripherals have been disabled and that the CPU is operating at the highest possible frequency (SYSCLK SEL = 100). NEWFREQ is the new frequency value (P and Q values) to be programmed. This routine enables the timer to wake the PLL up after two CLK32 “ticks”. When the PLL wakes up, it will be at the new frequency. The interrupt service routine for the temporary timer interrupt should clear the timer interrupt and then return. In addition, the master frequency should only be changed during an early phase of the boot-up sequence. Keep in mind, this code was written for clarity, not efficiency.

```

NEWFREQ      equ somevalue           ;P and Q value of new frequency
PLLCONTROL   equ $FFF200             ;PLL Control Register
PLLFREQ      equ $FFFF202           ;PLL Frequency Control Register
TCOMPARE     equ $FFF604            ;Timer Compare Value Register
TCONTROL     equ $FFF600            ;Timer Control Register
IMR          equ $FFF304            ;Interrupt Mask Register

                move.l IMR,-(SP)      ;save the Interrupt Mask register
                move.l #$fffffffd,IMR ;enable ONLY Timer interrupt
                move.w #$0001,TCOMPARE ;set compare value to 2
                move.w #$0119,TCONTROL ;enable Timer 2 with CLK32 source
SYNC1         btst.b #$7,PLLFREQ     ;synchronize to CLK32 high level
                beq.s SYNC1           ;CLK32 is still not high, go back
SYNC2         btst.b #$7,PLLFREQ     ;synchronize to CLK32 low level
                bne.s SYNC2           ;CLK32 is still not low, go back
                move.w #NEWFREQ,PLLFREQ ;load the new frequency
                ori.b #$8,PLLCONTROL+1 ;disable the PLL (in 30 clocks)
                stop #$2000           ;stop, enable all interrupts
; the PLL shuts down here and waits for the Timer interrupt
; interrupt service for Timer occurs here
                move.w (SP)+,IMR      ;restore the Interrupt Mask Register
                rts                   ;PLL is now at the new frequency
; The PLL has reacquired lock and SYSCLK is stable

```

5.1.5 PLL Operation at System Shut-Down

Shutting the PLL down to place the system in sleep mode is similar to the process used to change the frequency. The difference is that the system can be awakened only by a wake-up event or reset. Before shutting the PLL down, make sure that all peripheral devices are prepared for shut-down. The PLL shuts down 30 clocks after the DISPLL bit is set in the PL control register so that there is enough time to execute the **stop** instruction. When a wake-up event occurs, the PLL is enabled and within 1ms it acquires lock and the system clock begins. The CPU executes an interrupt service routine for the level of the wake-up event.

After the **rte** instruction in the wake-up service routine, the CPU returns and starts execution on the instruction following the **stop** instruction. The instruction sequence below illustrates a typical shut-down sequence. It assumes that all peripherals have been shut down before the PLL is stopped.

Freescale Semiconductor, Inc.

Phase-Locked Loop and Power Control

```

move.w    #$2410,$FFF200    ;Set PLL to full running
SYNC1    btst.b    #$7,$FFF202    ;look for 32K clock low
        bne.s     SYNC1",
SYNC2    btst.b    #$7,$FFF202    ;look for 32K clcok high
        beq.s     SYNC2
move.w    #$2418,$FFF200    ;Stop PLL
stop     #$2000            ;enable wake up event

```

5.2 PROGRAMMING MODEL

5.2.1 PLL Control Register

The PLL control register (PLLCR) controls how the PLL operates.

PLLCR

BIT	15	14	13	12	11	10	9	8	7	6	5	4	3	2	1	0
FIELD	RESERVED		LCDCLK SEL			SYSCLK SEL			RESERVED		PRES C	CLKEN	DISPLL	RESERVED		
RESET	0x2420															
ADDR	0x(FF)FFF200															

Bits 15–14—Reserved

These bits are reserved and should be set to 0.

LCDCLK SEL—LCD Clock Selection

This field selects the master frequency for the LCD pixel clock. The master clock is derived from the VCO frequency.

- 000 = DMACLK ÷ 2.
- 001 = DMACLK ÷ 4.
- 010 = DMACLK ÷ 8.
- 011 = DMACLK ÷ 16.
- 1xx = DMACLK ÷ 1 (binary 100 after reset).

SYSCLK SEL—System Clock Selection

This field selects the master frequency for the MC68EZ328 microprocessor system clock. The master clock is derived from the VCO frequency. This field can be changed at any time. The VCO frequency is unaffected by changes.

- 000 = DMACLK ÷ 2.
- 001 = DMACLK ÷ 4.
- 010 = DMACLK ÷ 8.
- 011 = DMACLK ÷ 16.
- 1xx = DMACLK ÷ 1 (binary 100 after reset).

Bits 7–6—Reserved

These bits are reserved and should be set to 0.

PRESA—Prescaler

This field selects the frequency for the LCD controller’s DMA clock and the other two dividers inside the MC68EZ328. This clock is derived from the VCO frequency. This field can be changed at any time.

- 0 = VCO ÷ 1.
- 1 = VCO ÷ 2.

CLKEN—Clock Enable

This bit enables the CLKO pin.

- 0 = CLKO/PF2 disabled.
- 1 = CLKO/PF2 enabled (default).

DISPLL—Disable PLL

This bit, when set, disables the PLL. The system clock is shut down and the MC68EZ328 assumes its lowest power state. Only the 32kHz clock runs. Refer to [Section 5.1.5 PLL Operation at System Shut-Down](#) for a description of the preferred method for system clock shut-down. Once the PLL is disabled, only a wake-up interrupt or reset can reenale it.

- 0 = PLL enabled (default).
- 1 = PLL disabled.

Bits 2–0—Reserved

These bits must remain at their default value.

5.2.2 PLL Frequency Select Register

The PLL frequency select register (PLLFSR) controls the two dividers of the dual-modulus counter. While this register can be accessed as bytes, it should always be written as a 16-bit word.

PLLFSR

BIT	15	14	13	12	11	10	9	8	7	6	5	4	3	2	1	0
FIELD	CLK ₃ 2	PROT	RESERVED					QC								PC
RESET	0x0123															
ADDR	0x(FF)FFF202															

CLK32—Clock 32

This read-only bit indicates the current status of the CLK32 signal and can be used to synchronize the software to the 32kHz reference clock.

PROT—Protect

This bit protects the “P” and “Q” counter values from additional writes. After this bit is set by software, the frequency select register cannot be written. Only a reset clears this bit.

Bits 13–12—Reserved

QC—Q Count

This field controls the “Q” counter.

PC—P Count

This field controls the “P” counter.

5.3 POWER CONTROL

The power control module of the MC68EZ328 improves power efficiency as it controls the allocation of power (clocks) to the CPU under software control. Since the clocks can be enabled in bursts, while executing tasks that require significant CPU resources, they can be enabled for extended periods of time. While the CPU is relatively idle, the clock can be disabled or bursted with a low duty-cycle. When a wake-up event occurs, the clock is immediately enabled, allowing the CPU to service the request. The DMA controller is not affected by the power controller. It has full access to the bus while the CPU is idle, keeping the LCD screen refreshed.

After reset, the power controller is disabled and the CPU clock is always on. When the block is enabled, software controls the clock burst width in increments of 1/31. Initially, the duty-cycle is set to 100%. Software can then change the duty-cycle to a lower value (including zero) and the clock begins to burst or stop. During normal operation, while the core is waiting for your input, the CPU clock can be shut down until such an input arrives.

An interrupt from the keyboard, for example, disables the power controller and runs the CPU clock. When the software finishes servicing the task, the power controller can again disable the clock and reduce power consumption. Clock control is in increments of approximately 3% (1/31).

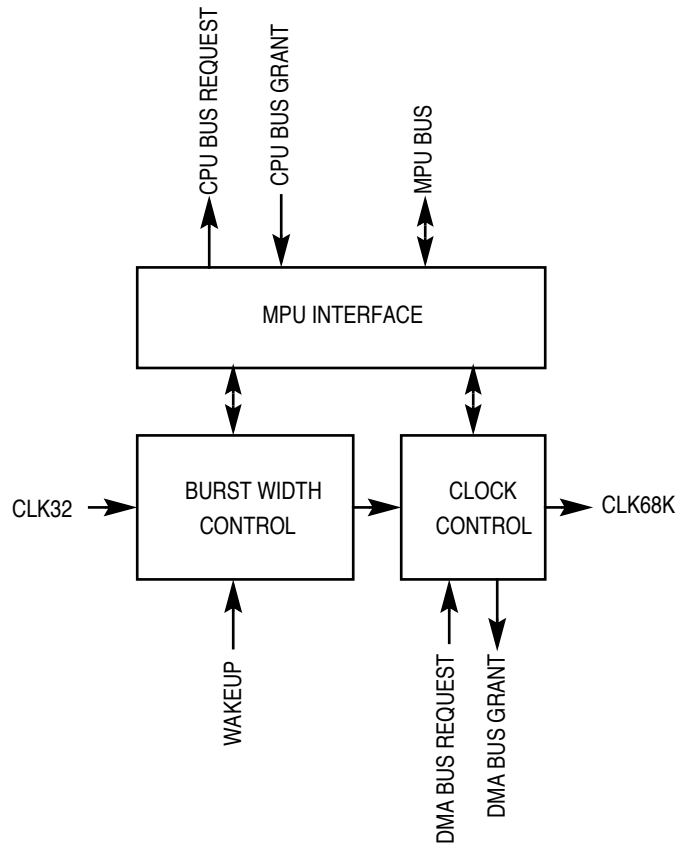

Figure 5-2. Power Control Module Block Diagram

When the burst-width control sub-block indicates that the CPU clock’s time-slot has expired and is to be disabled, clock control requests the bus from the CPU. After the bus is granted, the clock stops. A bus grant to the DMA controller is asserted and the DMA controller has complete access to the bus. If a wake-up event occurs while the CPU clock is disabled, the clock is immediately enabled and the CPU processes the event. The DMA controller always has priority, so if a DMA access is in progress, the CPU will wait until the DMA controller has completed its access before wake-up processing begins.

Figure 5-3 illustrates how the power controller operates. In this example, the clock bursts at about a 15% duty-cycle, so the core is active about 15% of the time. The remainder of the time, the core is in sleep mode. When a wake-up event occurs, the clock immediately restarts so the processor can service the wake-up event interrupt. The power controller burst period is 31 CLK32 periods or approximately 1msec. Notice that the LCD DMA controller has access to the bus at all times and the SYCLK (master clock to all peripherals) is continuously active.

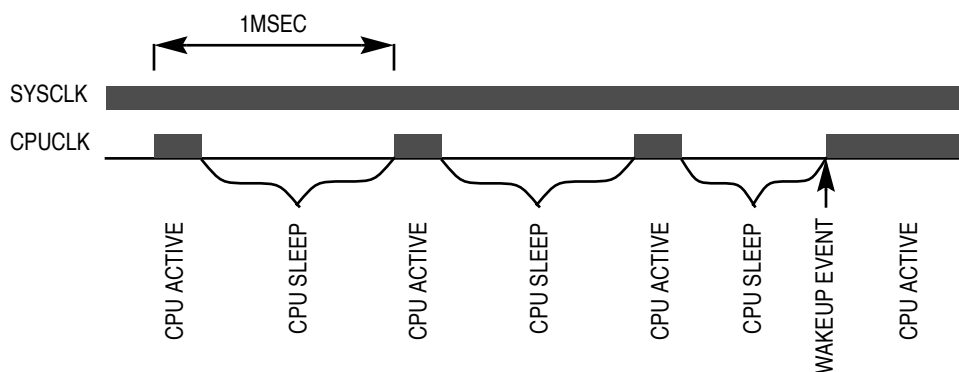

Figure 5-3. Power Control Operation

5.3.1 Operating the Power Control Module

The power control module has three modes of operation:

- Normal
- Doze
- Sleep

5.3.1.1 NORMAL MODE. When the MC68EZ328 microprocessor starts operating after reset, the power control module is disabled and the CPU clock runs continuously. To reduce the power consumed by the core, set the PCEN bit in the PCTLR register. The value of the WIDTH bit in the PCTLR register determines the duty-cycle of the clock burst that is applied to the core. If a wake-up event is received, the power control module is immediately disabled and continuous clocks are supplied. It is up to the wake-up service routine to reenables the power control module.

5.3.1.2 DOZE MODE. The core's clock can be disabled for extended periods of time by setting the WIDTH bit to 00000. The core's clock is immediately enabled when it receives a wake-up event. At the end of the service routine, the power control module can be reenables, putting the core back into doze mode. Once the CPU clock is disabled, only a wake-up event or hardware reset will reenables it. For various core resource requirements, you can program the duty-cycle register for burst-duty cycles of any value between 0/31 and 31/31. This effectively provides a variable clock frequency (and power dissipation) between 0% and 100% of the system clock frequency in 3% incremental steps.

The most effective power control strategy is to run the CPU at the highest system speed until no CPU cycles are needed, then enter doze mode. You can do this by writing 0x80 into the power control register. This disables the CPU clock at the earliest possible moment, but allows the CPU to immediately respond to wake-up events. The peripheral devices, including the LCD controller, are not affected by the power control module.

5.3.1.3 SLEEP MODE. The PLL is disabled in sleep mode. Only the 32kHz clock works to keep the real-time clock operational. Wake-up events activate the PLL and the system clock starts operating after 1msec.

5.3.2 Power Control Register

The power control register (PCTLR) is used to control how much power you are using in the system.

PCTLR

BIT	7	6	5	4	3	2	1	0
FIELD	PCEN	RESERVED	0	WIDTH				
RESET	0x001F							
ADDR	0x(FF)FFF207							

PCEN—Power Control Enable

This bit controls the operation of the power control module. While this bit is low, the CPU clock is on continuously. While this bit is high, the width comparator presents the clock to the core in bursts or disables it. When this bit is clear, a masked interrupt can disable the power control module. Your interrupt service routine must reenale this bit to reenter power-saving operation.

- 0 = Power control is disabled (default).
- 1 = Power control is enabled.

Bit 6—Reserved

This bit is reserved and should be set to 0.

WIDTH—Width of CPU Clock Bursts

This field resets to 11111 (0x1F). It controls the width of the CPU clock bursts in 1/31 increments. While this bit is set to 1 and the power control module is enabled, the clock is bursted to the CPU at a duty-cycle of 1/31. When the WIDTH field is 1F(hex), the clock is always on and when it is zero, the clock is always off. Set the WIDTH field to 0 when the CPU will be disabled for an extended amount of time. You can immediately wake it up again without waiting for the PLL to reacquire lock.

This field is not affected by the PCEN bit. When an interrupt disables the power control module, these bits are not changed. You should reenale the power control module that services the interrupt.

- 00000 = 0/31 duty-cycle.
- 00001 = 1/31 duty-cycle.
- 00010 = 2/31 duty-cycle.
-
-
-
- 11111 = 31/31 duty-cycle.

SECTION 6

INTERRUPT CONTROLLER

The interrupt controller supports 18 edge- and level-sensitive interrupts. There are seven interrupt levels. Level 7 has the highest priority and level 1 has the lowest. Interrupts can originate from the following sources:

- $\overline{\text{EMUIRQ}}$ (level 7)
- $\overline{\text{IRQ6}}$ external interrupt (level 6)
- Timer (level 6)
- Pulse-width modulator (level 6)
- $\overline{\text{IRQ5}}$ external interrupt–pen (level 5)
- Serial peripheral interface (level 4)
- UART needs service–transmit or receive (level 4)
- Software watchdog timer interrupt (level 4)
- Real-time clock interrupt (level 4)
- Real-time clock sampling interrupt (level 4)
- Keyboard interrupt (level 4)
- General-purpose interrupt $\overline{\text{INT}}[3:0]$ (level 4). These pins can be used as keyboard interrupts.
- $\overline{\text{IRQ3}}$ external interrupt (level 3)
- $\overline{\text{IRQ2}}$ external interrupt (level 2)
- $\overline{\text{IRQ1}}$ external interrupt (level 1)

6.1 INTERRUPT PROCESSING

Interrupts are processed in the following sequence on the MC68EZ328:

1. The interrupt controller collects interrupt events from on- and off-chip peripherals, prioritizes them, and presents the highest priority request to the core processor if there are no higher interrupts pending. Otherwise, the higher interrupt will be served first.
2. The core processor responds to the interrupt request by executing an interrupt acknowledge bus cycle after the completion of the current instruction.
3. The interrupt controller recognizes the interrupt acknowledge (IACK) cycle and places the interrupt vector for that interrupt request onto the core processor bus.

4. The core processor reads the vector and address of the interrupt handler in the exception vector table and begins execution at that address.

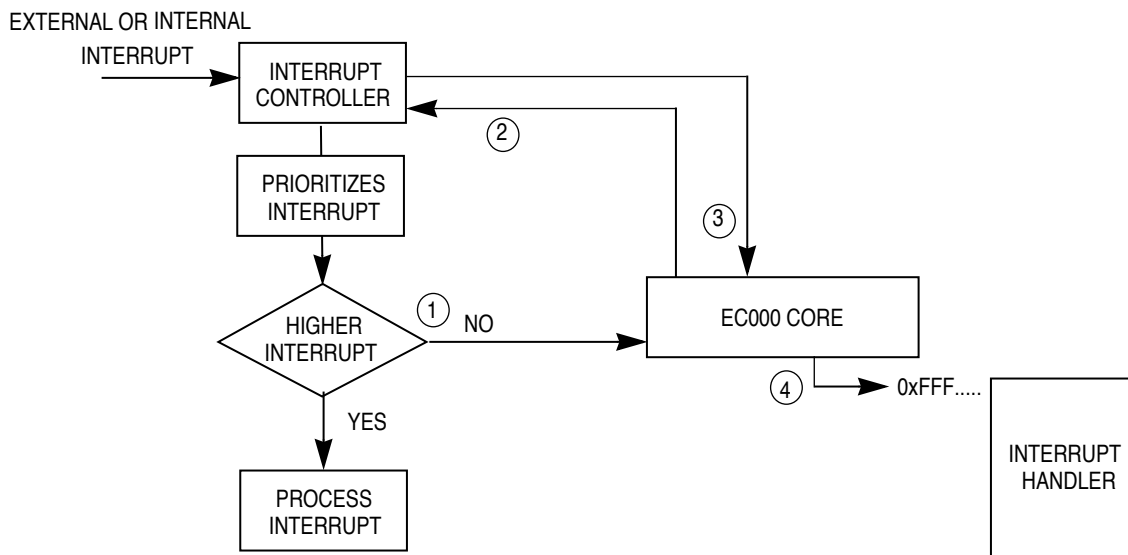

Figure 6-1. Interrupt Processing Flowchart

Steps 2 and 4 are the responsibility of the core processor, whereas steps 1 and 3 are the responsibility of the interrupt controller. External devices are forbidden from responding to IACK cycles with a vector because it is the responsibility of the interrupt controller.

On the MC68EZ328, steps 2 and 4 operate exactly as they would on other M68000 devices, which are described in the M68000 User's Manual. In step 2, the core processor's status register (SR) is available to mask interrupts globally or to determine which priority levels can currently generate interrupts. Also in step 2, the interrupt acknowledge cycle is executed.

In step 4, the core processor reads the vector number, multiplies it by four to get the vector address, fetches a 4-byte program address from that vector address, and then jumps to that 4-byte address. This 4-byte address is the location of the first instruction in the interrupt handler.

The interrupt priority is based on the interrupt level. The interrupts with the same interrupt level are prioritized by the software during the execution of the interrupt service routine. The MC68EZ328 provides one interrupt vector for each interrupt level. You can program the most-significant five bits of the interrupt vector, but the lower three bits reflect the interrupt level that is being serviced. All interrupts are maskable. Writing a 1 to a bit in the interrupt mask register disables that interrupt. If an interrupt is masked, you can find out its status in the interrupt pending register.

6.2 EXCEPTION VECTORS

A vector number is an 8-bit number that can be multiplied by four to obtain the address of an exception vector. An exception vector is the memory location from which the processor fetches the address of a software routine that is used to handle an exception. Each exception has a vector number and an exception vector, as described in Table 6-1. User interrupts are part of the exception processing on the MC68EZ328 and the vector numbers for user interrupts are configurable. For additional information regarding exception processing, see the M68000 Programmer's Reference Manual.

Table 6-1. Exception Vector Assignment

VECTORS NUMBERS		ADDRESS		SPACE	ASSIGNMENT
HEX	DECIMAL	DECIMAL	HEX		
0	0	0	000	SP	Reset: Initial SSP
1	1	4	004	SP	Reset: Initial PC
2	2	8	008	SD	Bus Error
3	3	12	00C	SD	Address Error
4	4	16	010	SD	Illegal Instruction
5	5	20	014	SD	Divide-by-Zero
6	6	24	018	SD	CHK Instruction
7	7	28	01C	SD	TRAPV Instruction
8	8	32	020	SD	Privilege Violation
9	9	36	024	SD	Trace
A	10	40	028	SD	Line 1010 Emulator
B	11	44	02C	SD	Line 1111 Emulator
C	12	48	030	SD	Unassigned, Reserved
D	13	52	034	SD	Unassigned, Reserved
E	14	56	038	SD	Unassigned, Reserved
F	15	60	03C	SD	Uninitialized Interrupt Vector
10–17	16–23	64	040	SD	Unassigned, Reserved
		92	05C		
18	24	96	060	SD	Spurious Interrupt
19	25	100	064	SD	Level 1 Interrupt Autovector
1A	26	104	068	SD	Level 2 Interrupt Autovector
1B	27	108	06C	SD	Level 3 Interrupt Autovector
1C	28	112	070	SD	Level 4 Interrupt Autovector
1D	29	116	074	SD	Level 5 Interrupt Autovector
1E	30	120	078	SD	Level 6 Interrupt Autovector
1F	31	124	07C	SD	Level 7 Interrupt Autovector

Table 6-1. Exception Vector Assignment (Continued)

20–2F	32–47	128	080	SD	TRAP Instruction Vectors
		188	0BC		
30–3F	48–63	192	0C0	SD	Unassigned, Reserved
		255	0FF		
40–FF	64–255	256	100	SD	User Interrupt Vectors
		1020	3FC		

NOTES:

1. Vector numbers 12–14, 16–23, and 48–63 are reserved for future enhancements by Motorola. None of your peripheral devices should be assigned to these numbers.
2. Reset vector 0 requires four words, unlike the other vectors which only require two words, and it is located in the supervisor program space.
3. The spurious interrupt vector is taken when there is a bus error indication during interrupt processing.
4. TRAP #n uses vector number 32+ n (decimal).
5. SP denotes supervisor program space and SD denotes supervisor data space.



Note: The MC68EZ328 does not provide autovector interrupts. At system start-up, you need to program the user interrupt vector so that the processor can handle interrupts properly.

6.3 RESET

The reset exception corresponds to the highest exception level. A reset exception is processed for system initialization and to recover from a catastrophic failure. Any processing that is in progress at the time of the reset is aborted and cannot be recovered. Neither the program counter nor the status register is saved. The processor is forced into the supervisor state. The interrupt priority mask is set at level 7. The address in the first 2 words of the reset exception vector is fetched by the processor as the initial SSP (Supervisor Stack Pointer), and the address in the next two words of the reset exception vector is fetched as the initial program counter.

At start-up or reset, the default chip-select ($\overline{CSA0}$) is asserted and all other chip-selects are negated. You should use $\overline{CSA0}$ to decode an EPROM/ROM memory space. In this case, the first two long-words of the EPROM/ROM memory space should be programmed to contain the initial SSP and PC. The initial SSP should point to a RAM space and the initial PC should point to the start-up code within the EPROM/ROM space so that the processor can execute the start-up code to bring up the system.



Note: The MC68EZ328 supports the **reset** instruction. However, the \overline{RESET} pin will not go low when you issue this instruction because it is an input-only signal.

The MC68EZ328's $\overline{\text{RESET}}$ signal should be held low for at least 100ms after the VDD and 32.768kHz/38.4kHz clocks are steady. After reset, all peripheral function signals and parallel I/O signals will appear as inputs with pull-up resistors turned on, unless otherwise specified. The muxed parallel I/O D[7:0]/PA[7:0] data bus will serve as the data bus if the $\overline{\text{BUSW}}$ signal is high during the rising edge of $\overline{\text{RESET}}$. If $\overline{\text{BUSW}}$ is low during the rising edge of $\overline{\text{RESET}}$, the D[7:0]/PA[7:0] pins will be input with a pulled high resistor.

Since the MC68EZ328 supports normal mode, emulation mode, and bootstrap mode and these operation modes are controlled by the $\overline{\text{EMUIRQ}}$, $\overline{\text{EMUBRK}}$ and $\overline{\text{HIZ}}$ signals during system reset, you should pay special attention when using these signals. Refer to for more information.

6.3.1 DATA BUS WIDTH FOR BOOT DEVICE OPERATION

The word size of the boot device (ROM/EPROM/FLASH) is determined by the $\overline{\text{BUSW}}$ signal. If it is high during the rising edge of the $\overline{\text{RESET}}$ signal, the 16-bit boot device will be configured. Otherwise, it will be configured as an 8-bit boot device.

6.4 INTERRUPT CONTROLLER OPERATION

When interrupts are received by the controller, they are prioritized and the highest enabled pending interrupt is posted to the core. Before the CPU responds to this interrupt, the status register is copied internally. Then the supervisor bit of the CPU status register is set, which puts the processor into supervisor mode. The CPU then responds with an interrupt acknowledge cycle, in which the lower 3 bits of the address bus reflect the level of the current interrupt. The interrupt controller generates a vector number during the interrupt acknowledge cycle and the CPU uses this vector number to generate a vector address. Except for the reset exception, the CPU saves the current processor status, including the program counter value (which points to the next instruction to be executed after the interrupt), and the saved copy of the interrupt status register. The new program counter is updated to the content of the interrupt vector, which points to the interrupt service routine. The CPU then resumes instruction execution to execute the interrupt service routine.

Interrupt priority is based on the interrupt level. If the CPU is currently processing an interrupt service routine and a higher priority interrupt is posted, the process described above repeats, and the higher priority interrupt is serviced. If the priority of the newer interrupt is lower than or equal to the priority of the current interrupt, execution of the current interrupt handler continues. This newer interrupt is postponed until its priority becomes the highest. Interrupts within a same level should be prioritized in software by the interrupt handler. The interrupt service routine should end with the **rte** instruction, which restores the processing state prior to the interrupt.

The MC68EZ328 provides one interrupt vector for each of the seven user interrupt levels. These interrupt vectors form the user interrupt vector section of Table 6-1. The user interrupt vectors can be located anywhere within the 0x100 to 0x400 address range. You can program the five most-significant bits of the interrupt vector number, but the lower three bits reflect the interrupt level that is being serviced. All interrupts are maskable by the interrupt controller. If an interrupt is masked, its status can still be accessed in the interrupt pending register (IPR).

6.5 VECTOR GENERATOR

The interrupt controller provides a vector number to the core. You can program the upper five bits of the interrupt vector register (IVR) to allow the interrupt vector number to point to any address in the exception vector table. However, many of the vector addresses are assigned to the core's internal exceptions and cannot be reused. This leaves only a small range of address space (0x100 to 0x400) that you can configure the IVR to locate user interrupt vectors. For example, if you write a value of 0x40 to the IVR, the interrupt vector base is set to point to 0x100 (0x40<<2), which is the beginning of the user interrupt vectors shown in Table 6-1. The coding for the vector numbers is provided in Table 6-2.

Table 6-2. Interrupt Vector Numbers

INTERRUPT	VECTOR NUMBER
Level 7	xxxxx111
Level 6	xxxxx110
Level 5	xxxxx101
Level 4	xxxxx100
Level 3	xxxxx011
Level 2	xxxxx010
Level 1	xxxxx001

NOTE: xxxxx is replaced by the upper five bits of the interrupt vector register.

6.6 PROGRAMMING MODEL

This section describes registers that you may need to configure so that the interrupt controller can properly process interrupts, generate vector numbers, and post interrupts to the core.

6.6.1 Interrupt Vector Register

The interrupt vector register (IVR) is used to program the upper five bits of the interrupt vector number. During the interrupt-acknowledge cycle, the lower three bits, encoded from the interrupt level, are combined with the upper five bits to form an 8-bit vector number. The CPU uses the vector number to generate a vector address. During system start-up, this register should be configured so that MC68EZ328's external and internal interrupts can be handled properly by their software handlers. If an interrupt occurs before the IVR has been programmed, the interrupt vector number 0x0F is returned to the CPU as an uninitialized interrupt, which has the interrupt vector 0x3C.

IVR

BIT	7	6	5	4	3	2	1	0
FIELD	VECTOR					RESERVED		

IVR

BIT	7	6	5	4	3	2	1	0
RESET	0x00							
ADDR	0x(FF)FFF300							

VECTOR

This field represents the upper five bits of the interrupt vector number.

Bits 2–0—Reserved

These bits are reserved and should be set to 0.

6.6.2 Interrupt Control Register

The interrupt control register (ICR) controls the behavior of the external interrupt inputs. It informs the interrupt controller whether the interrupt signal is an edge-triggered or level-sensitive interrupt, as well as whether it has positive or negative polarity.

ICR

BIT	15	14	13	12	11	10	9	8	7	6	5	4	3	2	1	0
FIELD	POL1	POL2	POL3	POL6	ET1	ET2	ET3	ET6	POL5	RESERVED						
RESET	0x0000															
ADDR	0x(FF)FFF302															

POL1—Polarity Control 1

This bit controls interrupt polarity for the $\overline{IRQ1}$ signal. In level-sensitive mode, negative polarity means that an interrupt occurs when the signal is at logic level low. Positive polarity means that an interrupt occurs when the signal is at logic level high. In edge-triggered mode, negative polarity means that an interrupt occurs when the signal goes from logic level high to logic level low. Positive polarity means that an interrupt occurs when the signal goes from logic level low to logic level high.

- 0 = Negative polarity.
- 1 = Positive polarity.

POL2—Polarity 2

This bit controls interrupt polarity for the $\overline{IRQ2}$ signal. In level-sensitive mode, negative polarity means that an interrupt occurs when the signal is at logic level low. Positive polarity means that an interrupt occurs when the signal is at logic level high. In edge-triggered mode, negative polarity means that an interrupt occurs when the signal goes from logic level high to logic level low. Positive polarity means that an interrupt occurs when the signal goes from logic level low to logic level high.

- 0 = Negative polarity.
- 1 = Positive polarity.

POL3—Polarity 3

This bit controls interrupt polarity for the $\overline{\text{IRQ3}}$ signal. In level-sensitive mode, negative polarity means that an interrupt occurs when the signal is at logic level low. Positive polarity means that an interrupt occurs when the signal is at logic level high. In edge-triggered mode, negative polarity means that an interrupt occurs when the signal goes from logic level high to logic level low. Positive polarity means that an interrupt occurs when the signal goes from logic level low to logic level high.

0 = Negative polarity.

1 = Positive polarity.

POL6—Polarity 6

This bit controls interrupt polarity for the $\overline{\text{IRQ6}}$ signal. In level-sensitive mode, negative polarity means that an interrupt occurs when the signal is at logic level low. Positive polarity means that an interrupt occurs when the signal is at logic level high. In edge-triggered mode, negative polarity means that an interrupt occurs when the signal goes from logic level high to logic level low. Positive polarity means that an interrupt occurs when the signal goes from logic level low to logic level high.

0 = Negative polarity.

1 = Positive polarity.



Note: Clear your interrupts after you change modes. When you change modes from level to edge interrupts, an edge can be created, which causes an interrupt to be posted.

ET1— $\overline{\text{IRQ1}}$ Edge Trigger Select

When this bit is set, the $\overline{\text{IRQ1}}$ signal is an edge-triggered interrupt. In edge-triggered mode, you must write a 1 to the $\overline{\text{IRQ1}}$ bit in the interrupt status register to clear this interrupt. When this bit is low, $\overline{\text{IRQ1}}$ is a level-sensitive interrupt. In this case, you must clear the external source of the interrupt.

0 = Level-sensitive interrupt.

1 = Edge-sensitive interrupt.

ET2— $\overline{\text{IRQ2}}$ Edge Trigger Select

When this bit is set, the $\overline{\text{IRQ2}}$ signal is an edge-triggered interrupt. In edge-triggered mode, you must write a 1 to the $\overline{\text{IRQ2}}$ bit in the interrupt status register to clear this interrupt. When this bit is low, $\overline{\text{IRQ2}}$ is a level-sensitive interrupt. In this case, you must clear the external source of the interrupt.

0 = Level-sensitive interrupt.

1 = Edge-sensitive interrupt.

ET3— $\overline{\text{IRQ3}}$ Edge Trigger Select

When this bit is set, the $\overline{\text{IRQ3}}$ signal is an edge-triggered interrupt. In edge-triggered mode, you must write a 1 to the IRQ3 bit in the interrupt status register to clear this interrupt. When this bit is low, $\overline{\text{IRQ3}}$ is a level-sensitive interrupt. In this case, you must clear the external source of the interrupt.

- 0 = Level-sensitive interrupt.
- 1 = Edge-sensitive interrupt.

ET6— $\overline{\text{IRQ6}}$ Edge Trigger Select

When this bit is set, the $\overline{\text{IRQ6}}$ signal is an edge-triggered interrupt. In edge-triggered mode, you must write a 1 to the IRQ6 bit in the interrupt status register to clear this interrupt. When this bit is low, $\overline{\text{IRQ6}}$ is a level-sensitive interrupt. In this case, you must clear the external source of the interrupt.

- 0 = Level-sensitive interrupt.
- 1 = Edge-sensitive interrupt.

POL5—Polarity 5

This bit controls the trigger polarity for the $\overline{\text{IRQ5}}$ signal, which is a level-sensitive external interrupt signal.

- 0 = Negative polarity.
- 1 = Positive polarity.

Bits 0–7—Reserved

These bits are reserved and should remain at their default value.

6.6.3 Interrupt Mask Register

The interrupt mask register (IMR) can mask out a particular interrupt if the corresponding bit for the interrupt is set. There is one control bit for each interrupt source. When an interrupt is masked, the interrupt controller will not generate an interrupt request to the CPU, but its status can still be observed in the interrupt pending register. At reset, all the interrupts are masked and all the bits in this register are set to 1.

IMR

BIT	31	30	29	28	27	26	25	24	23	22	21	20	19	18	17	16
FIELD	RESERVED								MEMIQ	MSAM	RES	MIRQ5	MIRQ6	MIRQ3	MIRQ2	MIRQ1
RESET	0x00FFFFFF															
BIT	15	14	13	12	11	10	9	8	7	6	5	4	3	2	1	0
FIELD	RESERVED				MINT3	MINT2	MINT1	MINT0	MPWM	MKB	RES	MRTC	MWDT	MUAR T	MTMR	MSPI
RESET	0x00FFFFFF															
ADDR	0x(FE)FFF304															

Interrupt Controller

Bits 31–24—Reserved

These bits are reserved and should be set to 0.

MEMIQ—Mask Emulator Interrupt

When this bit is set, it indicates that the $\overline{\text{EMUIRQ}}$ pin and in-circuit emulation breakpoint interrupt functions are masked. It is set to 1 after reset. These interrupts are level 7 interrupts to the core.

0 = Enable $\overline{\text{EMUIRQ}}$ interrupt.

1 = Mask $\overline{\text{EMUIRQ}}$ interrupt.

MSAM—Sampling Timer for Real-Time Clock

When this bit is set, it indicates that the sampling timer is masked. It is set to 1 after reset.

0 = Sampling timer is not masked.

1 = Sampling timer is masked.

Bit 21—Reserved

This bit is reserved and should be set to 0.

MIRQ5—Mask $\overline{\text{IRQ5}}$ Interrupt

0 = Enable $\overline{\text{IRQ5}}$ interrupt.

1 = Mask $\overline{\text{IRQ5}}$ interrupt.

MIRQ6—Mask $\overline{\text{IRQ6}}$ Interrupt

0 = Enable $\overline{\text{IRQ6}}$ interrupt.

1 = Mask $\overline{\text{IRQ6}}$ interrupt.

MIRQ3—Mask $\overline{\text{IRQ3}}$ Interrupt

0 = Enable $\overline{\text{IRQ3}}$ interrupt.

1 = Mask $\overline{\text{IRQ3}}$ interrupt.

MIRQ2—Mask $\overline{\text{IRQ2}}$ Interrupt

0 = Enable $\overline{\text{IRQ2}}$ interrupt.

1 = Mask $\overline{\text{IRQ2}}$ interrupt.

MIRQ1—Mask $\overline{\text{IRQ1}}$ Interrupt

0 = Enable $\overline{\text{IRQ1}}$ interrupt.

1 = Mask $\overline{\text{IRQ1}}$ interrupt.

Bits 15–12—Reserved

These bits are reserved and should be set to 0.

MINT3—Mask External $\overline{\text{INT3}}$ Interrupt

0 = Enable $\overline{\text{INT3}}$ interrupt.

1 = Mask $\overline{\text{INT3}}$ interrupt.

MINT2—Mask External $\overline{\text{INT2}}$ Interrupt

0 = Enable $\overline{\text{INT2}}$ interrupt.

1 = Mask $\overline{\text{INT2}}$ interrupt.

MINT1—Mask External $\overline{\text{INT1}}$ Interrupt

0 = Enable $\overline{\text{INT1}}$ interrupt.

1 = Mask $\overline{\text{INT1}}$ interrupt.

MINT0—Mask External $\overline{\text{INT0}}$ Interrupt

0 = Enable $\overline{\text{INT0}}$ interrupt.

1 = Mask $\overline{\text{INT0}}$ interrupt.

MPWM—Mask PWM Interrupt

0 = Enable pulse-width modulator interrupt.

1 = Mask pulse-width modulator interrupt.

MKB—Mask Keyboard Interrupt

0 = Enable keyboard interrupt.

1 = Mask keyboard interrupt.

Bit 5—Reserved

This bit is reserved and should be set to 0.

MRTC—Mask RTC Interrupt

0 = Enable real-time clock interrupt.

1 = Mask real-time clock interrupt.

MWDT—Mask Watchdog Timer Interrupt

0 = Enable watchdog timer interrupt.

1 = Mask watchdog timer interrupt.

MUART—Mask UART Interrupt

0 = Enable UART interrupt.

1 = Mask UART interrupt.

MTMR—Mask Timer Interrupt

0 = Enable timer interrupt.

1 = Mask timer interrupt.

MSPI—Mask SPI Interrupt

0 = Enable serial peripheral interface interrupt.

1 = Mask serial peripheral interface interrupt.

6.6.4 Interrupt Status Register

During the interrupt service, the interrupt handler can determine the source of the interrupt by examining the interrupt status register (ISR). When the bits in this register are set, they

Interrupt Controller

indicate that the corresponding interrupt is posted to the core. If there are multiple interrupt sources at the same level, the software handler may need to prioritize them, depending on the application.

Each interrupt status bit in this register reflects the interrupt request from their respective interrupt sources. Refer to [Section 9.2.6 Timer Status Register](#), [Section 10.2.2 SPIM Control/Status Register](#), [Section 13.2.5 RTC Interrupt Status Register](#), and [Section 8.2.1 PWM Control Register](#) for details about how to clear the different interrupts. When programmed as edge-triggered interrupts, the $\overline{IRQ1}$, $\overline{IRQ2}$, $\overline{IRQ3}$, and $\overline{IRQ6}$ interrupts can be cleared by writing a 1 to the corresponding status bit in the register. When programmed as level-triggered interrupts, these interrupts are cleared at the requesting sources.

ISR

BIT	31	30	29	28	27	26	25	24	23	22	21	20	19	18	17	16
FIELD	RESERVED								EMIQ	SAM	RES	IRQ5	IRQ6	IRQ3	IRQ2	IRQ1
RESET	0x00000000															
BIT	15	14	13	12	11	10	9	8	7	6	5	4	3	2	1	0
FIELD	RESERVED				INT3	INT2	INT1	INT0	PWM	KB	RES	RTC	WDT	UART	TMR	SPI
RESET	0x00000000															
ADDR	0x(FF)FFF30C															

Bits 31–24—Reserved

These bits are reserved and should be set to 0.

EMIQ—Emulator Interrupt Status

When this bit is set, it indicates that the in-circuit emulation module or \overline{EMUIRQ} pin is requesting an interrupt on level 7. This bit can be generated from three interrupt sources: two breakpoint interrupts from the in-circuit emulation module and an external interrupt from \overline{EMUIRQ} , which is an active low edge-sensitive interrupt. To clear this interrupt, you must read the ICEMSR register to identify the interrupt source and write a 1 to the corresponding bit of that register. See [Section 15.2.4 In-Circuit Emulation Module Status Register](#) for more information.

- 0 = No emulator interrupt is pending.
- 1 = An emulator interrupt is pending.

SAM—Sampling Timer of Real-Time Clock

When this bit is set, it indicates that the sampling timer has reached its predefined frequency count. The frequency can be selected inside the real-time clock module, which can function as an additional timer.

Bit 21—Reserved

This bit is reserved and should be set to 0.

IRQ5—Interrupt Request Level 5

When this bit is set, it indicates that an external device is requesting an interrupt on level 5. If the $\overline{\text{IRQ5}}$ signal is set to be a level-sensitive interrupt, you must clear the source of the interrupt. If $\overline{\text{IRQ5}}$ is set to be an edge-triggered interrupt, you must clear the interrupt by writing a 1 to this bit. Writing a 0 to this bit has no effect.

0 = No level 5 interrupt is pending.

1 = A level 5 interrupt is posted.

IRQ6—Interrupt Request Level 6

When this bit is set, it indicates that an external device is requesting an interrupt on level 6. If the $\overline{\text{IRQ6}}$ signal is set to be a level-sensitive interrupt, you must clear the source of the interrupt. If $\overline{\text{IRQ6}}$ is set to be an edge-triggered interrupt, you must clear the interrupt by writing a 1 to this bit. Writing a 0 to this bit has no effect.

0 = No level 6 interrupt is pending.

1 = A level 6 interrupt is posted.

IRQ3—Interrupt Request Level 3

When set, this bit indicates that an external device has requested an interrupt on level 3. If the $\overline{\text{IRQ3}}$ signal is set to be a level-sensitive interrupt, you must clear the source of the interrupt. If $\overline{\text{IRQ3}}$ is set to be an edge-triggered interrupt, you must clear the interrupt by writing a 1 to this bit (writing a 0 has no effect).

0 = No level 3 interrupt is pending.

1 = A level 3 interrupt is pending.

IRQ2—Interrupt Request Level 2

When set, this bit indicates that an external device has requested an interrupt on level 2. If the $\overline{\text{IRQ2}}$ signal is set to be a level-sensitive interrupt, you must clear the source of the interrupt. If $\overline{\text{IRQ2}}$ is set to be an edge-triggered interrupt, you must clear the interrupt by writing a 1 to this bit (writing a 0 has no effect).

0 = No level 2 interrupt is pending.

1 = A level 2 interrupt is pending.

IRQ1—Interrupt Request Level 1

When set, this bit indicates that an external device has requested an interrupt on level 1. If the $\overline{\text{IRQ1}}$ signal is set to be a level-sensitive interrupt, you must clear the source of the interrupt. If $\overline{\text{IRQ1}}$ is set to be an edge-triggered interrupt, you must clear the interrupt by writing a 1 to this bit (writing a 0 has no effect).

0 = No level 1 interrupt is pending.

1 = A level 1 interrupt is pending.

Interrupt Controller

INT7— External $\overline{\text{INT7}}$ Interrupt

This bit indicates that a level 4 interrupt has occurred. It is usually for a keyboard interface. When it is programmed as edge-triggered, it can only be cleared by writing a 1 to the port D register, which is described in [Section 7.2.4 Port D Registers](#).

- 0 = No $\overline{\text{INT7}}$ interrupt is pending.
- 1 = An $\overline{\text{INT7}}$ interrupt is pending.

INT6— External $\overline{\text{INT6}}$ Interrupt

This bit indicates that a level 4 interrupt has occurred. It is usually for a keyboard interface. When it is programmed as edge-triggered, it can only be cleared by writing a 1 to the port D register, which is described in [Section 7.2.4 Port D Registers](#).

- 0 = No $\overline{\text{INT6}}$ interrupt is pending.
- 1 = An $\overline{\text{INT6}}$ interrupt is pending.

INT5—External $\overline{\text{INT5}}$ Interrupt

This bit indicates that a level 4 interrupt has occurred. It is usually for a keyboard interface. When it is programmed as edge-triggered, it can only be cleared by writing a 1 to the port D register, which is described in [Section 7.2.4 Port D Registers](#).

- 0 = No $\overline{\text{INT5}}$ interrupt is pending.
- 1 = An $\overline{\text{INT5}}$ interrupt is pending.

INT4—External $\overline{\text{INT4}}$ Interrupt

This bit indicates that a level 4 interrupt has occurred. It is usually for a keyboard interface. When it is programmed as edge-triggered, it can only be cleared by writing a 1 to the port D register, which is described in [Section 7.2.4 Port D Registers](#).

- 0 = No $\overline{\text{INT4}}$ interrupt is pending.
- 1 = An $\overline{\text{INT4}}$ interrupt is pending.

INT3—External $\overline{\text{INT3}}$ Interrupt

This bit indicates that a level 4 interrupt has occurred. It is usually for a keyboard interface. When it is programmed as edge-triggered, it can only be cleared by writing a 1 to the port D register, which is described in [Section 7.2.4 Port D Registers](#).

- 0 = No $\overline{\text{INT3}}$ interrupt is pending.
- 1 = An $\overline{\text{INT3}}$ interrupt is pending.

INT2—External $\overline{\text{INT2}}$ Interrupt

This bit indicates that a level 4 interrupt has occurred. It is usually for a keyboard interface. When it is programmed as edge-triggered, it can only be cleared by writing a 1 to the port D register, which is described in [Section 7.2.4 Port D Registers](#).

- 0 = No $\overline{\text{INT2}}$ interrupt is pending.
- 1 = An $\overline{\text{INT2}}$ interrupt is pending.

INT1—External $\overline{\text{INT1}}$ Interrupt

This bit indicates that a level 4 interrupt has occurred. It is usually for a keyboard interface. When it is programmed as edge-triggered, it can only be cleared by writing a 1 to the port D register, which is described in [Section 7.2.4 Port D Registers](#).

- 0 = No $\overline{\text{INT1}}$ interrupt is pending.
- 1 = An $\overline{\text{INT1}}$ interrupt is pending.

INT0—External $\overline{\text{INT0}}$ Interrupt

This bit indicates that a level 4 interrupt has occurred. It is usually for a keyboard interface. When it is programmed as edge-triggered, it can only be cleared by writing a 1 to the port D register, which is described in [Section 7.2.4 Port D Registers](#).

- 0 = No $\overline{\text{INT0}}$ interrupt is pending.
- 1 = An $\overline{\text{INT0}}$ interrupt is pending.

PWM—Pulse-Width Modulator Interrupt

This bit indicates that a PWM period rollover event has occurred. This is a level 6 interrupt.

- 0 = No pulse-width modulator period rollover event occurred.
- 1 = A pulse-width modulator period rolled over.

KB—Keyboard Interrupt Request

This bit indicates whether there is a keyboard interrupt. This is a level 4 interrupt.

- 0 = No keyboard interrupt is pending.
- 1 = A keyboard interrupt is pending.

Bit 5—Reserved

This bit is reserved and should remain at its default value.

RTC—Real-Time Clock Interrupt Request

This bit indicates that the real-time clock is requesting an interrupt. This is a level 4 interrupt.

- 0 = No real-time clock interrupt is pending.
- 1 = A real-time clock interrupt is pending.

WDT—Watchdog Timer Interrupt Request

This bit indicates that a watchdog timer interrupt is pending. This is a level 4 interrupt.

- 0 = No watchdog timer interrupt is pending.
- 1 = A watchdog timer interrupt is pending.

Interrupt Controller

UART—UART Interrupt Request

When this bit is set, it indicates that the UART module needs service. This is a level 4 interrupt.

- 0 = No UART service request is pending.
- 1 = UART service is needed.

TMR—Timer Interrupt Status

This bit indicates that a timer event has occurred. This is a level 6 interrupt.

- 0 = No timer event occurred.
- 1 = A timer event has occurred.

SPI—SPI Interrupt Status

When this bit is set, it indicates that a data transfer is complete. You must clear this interrupt in the SPIMCONT register, which is described in [Section 10.2.2 SPIM Control/Status Register](#). This interrupt is a level 4 interrupt.

- 0 = No SPI interrupt is pending.
- 1 = An SPI interrupt is posted.

6.6.5 Interrupt Pending Register

The read-only interrupt pending register (IPR) indicates which interrupts are pending. If an interrupt source requests an interrupt, but that interrupt is masked by the interrupt mask register, then that interrupt bit will be set in this register, but not in the interrupt status register. If the pending interrupt is not masked, the interrupt bit will be set in both registers.

IPR

BIT	31	30	29	28	27	26	25	24	23	22	21	20	19	18	17	16
FIELD	RESERVED								EMIQ	SAM	RES	IRQ5	IRQ6	IRQ3	IRQ2	IRQ1
RESET	0x00000000															
BIT	15	14	13	12	11	10	9	8	7	6	5	4	3	2	1	0
FIELD	RESERVED				INT3	INT2	INT1	INT0	PWM	KB	RES	RTC	WDT	UART	TMR	SPI
RESET	0x00000000															
ADDR	0x(FF)FFF310															

Bits 31–24—Reserved

These bits are reserved and should be set to 0.

EMIQ—Emulator Interrupt Status

This bit indicates that the in-circuit emulation module or $\overline{\text{EMUIRQ}}$ pin is requesting an interrupt on level 7. This bit can be generated from three interrupt sources—two breakpoint interrupts from in-circuit emulation module and an external interrupt from $\overline{\text{EMUIRQ}}$, which is

an active low edge-sensitive interrupt. To clear this interrupt, you must read the ICEMSR register to identify the interrupt source and write a 1 to the corresponding bit in the ICEMSR. See [Section 15.2.4 In-Circuit Emulation Module Status Register](#) for more information.

- 0 = No $\overline{\text{EMUIRQ}}$ interrupt is pending.
- 1 = An EMUIRQ interrupt is pending.

SAM—Sampling Timer of Real-Time Clock

This bit indicates that the sampling timer has reached its predefined frequency count. The frequency can be selected inside the real-time clock module, which can function as an additional timer.

Bit 21—Reserved

This bit is reserved and should be set to 0.

IRQ5—Interrupt Request Level 5

This bit indicates that an external device is requesting an interrupt on level 5. If the $\overline{\text{IRQ5}}$ signal is set to be a level-sensitive interrupt, you must clear the source of the interrupt. If $\overline{\text{IRQ5}}$ is set to be an edge-triggered interrupt, you must clear the interrupt by writing a 1 to this bit. Writing a 0 to this bit has no effect.

- 0 = No level 5 interrupt is pending.
- 1 = A level 5 interrupt is posted.

IRQ6—Interrupt Request Level 6

This bit indicates that an external device is requesting an interrupt on level 6. If the $\overline{\text{IRQ6}}$ signal is set to be a level-sensitive interrupt, you must clear the source of the interrupt. If $\overline{\text{IRQ6}}$ is set to be an edge-triggered interrupt, you must clear the interrupt by writing a 1 to this bit. Writing a 0 to this bit has no effect.

- 0 = No level 6 interrupt is pending.
- 1 = A level 6 interrupt is posted.

IRQ3—Interrupt Request Level 3

This bit indicates that an external device has requested an interrupt on level 3. If the $\overline{\text{IRQ3}}$ signal is set to be a level-sensitive interrupt, you must clear the source of the interrupt. If $\overline{\text{IRQ3}}$ is set to be an edge-triggered interrupt, you must clear the interrupt by writing a 1 to this bit (writing a 0 has no effect).

- 0 = No level 3 interrupt is pending.
- 1 = A level 3 interrupt is pending.

IRQ2—Interrupt Request Level 2

This bit indicates that an external device has requested an interrupt on level 2. If the $\overline{\text{IRQ2}}$ signal is set to be a level-sensitive interrupt, you must clear the source of the interrupt. If

Interrupt Controller

$\overline{\text{IRQ2}}$ is set to be an edge-triggered interrupt, you must clear the interrupt by writing a 1 to this bit (writing a 0 has no effect).

- 0 = No level 2 interrupt is pending.
- 1 = A level 2 interrupt is pending.

IRQ1—Interrupt Request Level 1

This bit indicates that an external device has requested an interrupt on level 1. If the $\overline{\text{IRQ1}}$ signal is set to be a level-sensitive interrupt, you must clear the source of the interrupt. If $\overline{\text{IRQ1}}$ is set to be an edge-triggered interrupt, you must clear the interrupt by writing a 1 to this bit (writing a 0 has no effect).

- 0 = No level 1 interrupt is pending.
- 1 = A level 1 interrupt is pending.

Bits 15–12—Reserved

These bits are reserved and should be set to 0.

INT3—External $\overline{\text{INT3}}$ Interrupt

This bit indicates that a level 4 interrupt has occurred. It is usually for a keyboard interface. When it is programmed as edge-triggered, it can only be cleared by writing a 1 to the port D register. See [Section 7.2.4 Port D Registers](#) for more information.

- 0 = No $\overline{\text{INT3}}$ interrupt is pending.
- 1 = An $\overline{\text{INT3}}$ interrupt is pending.

INT2—External $\overline{\text{INT2}}$ Interrupt

This bit indicates that a level 4 interrupt has occurred. It is usually for a keyboard interface. When it is programmed as edge-triggered, it can only be cleared by writing a 1 to the port D register. See [Section 7.2.4 Port D Registers](#) for more information.

- 0 = No $\overline{\text{INT2}}$ interrupt is pending.
- 1 = An $\overline{\text{INT2}}$ interrupt is pending.

INT1—External $\overline{\text{INT1}}$ Interrupt

This bit indicates that a level 4 interrupt has occurred. It is usually for a keyboard interface. When it is programmed as edge-triggered, it can only be cleared by writing a 1 to the port D register. See [Section 7.2.4 Port D Registers](#) for more information.

- 0 = No $\overline{\text{INT1}}$ interrupt is pending.
- 1 = An $\overline{\text{INT1}}$ interrupt is pending.

INT0—External $\overline{\text{INT0}}$ Interrupt

This bit indicates that a level 4 interrupt has occurred. It is usually for a keyboard interface. When it is programmed as edge-triggered, it can only be cleared by writing a 1 to the port D register. See [Section 7.2.4 Port D Registers](#) for more information.

- 0 = No $\overline{\text{INT0}}$ interrupt is pending.
- 1 = An $\overline{\text{INT0}}$ interrupt is pending.

PWM—Pulse-Width Modulator Interrupt

This bit indicates that a PWM period rollover event has occurred. This is a level 6 interrupt.

- 0 = No pulse-width modulator period rollover event occurred.
- 1 = A pulse-width modulator period rolled over.

KB—Keyboard Interrupt Request

This bit indicates whether there is a keyboard interrupt. This is a level 4 interrupt.

- 0 = No keyboard interrupt is pending.
- 1 = A keyboard interrupt is pending.

Bit 5—Reserved

This bit is reserved and should remain at its default value.

RTC—Real-Time Clock Interrupt Request

This bit indicates that the real-time clock is requesting an interrupt. This is a level 4 interrupt.

- 0 = No real-time clock interrupt is pending.
- 1 = A real-time clock interrupt is pending.

WDT—Watchdog Timer Interrupt Request

This bit indicates that a watchdog timer interrupt is pending. This is a level 4 interrupt.

- 0 = No watchdog timer interrupt is pending.
- 1 = A watchdog timer interrupt is pending.

UART—UART Interrupt Request

When this bit is set, it indicates that the UART module needs service. This is a level 4 interrupt.

- 0 = No UART service request is pending.
- 1 = UART service is needed.

TMR—Timer Interrupt Status

This bit indicates that a timer event has occurred. This is a level 6 interrupt.

- 0 = No timer event has occurred.
- 1 = A timer event has occurred.

SPI—SPI Interrupt Status

When this bit is set, it indicates that a data transfer is complete. You must clear this interrupt in the SPIMCONT register, which is described in [Section 10.2.2 SPIM Control/Status Register](#). This interrupt is a level 4 interrupt.

- 0 = No SPI interrupt is pending.
- 1 = An SPI interrupt is posted.

6.7 KEYBOARD INTERRUPTS

Keyboard interrupt features provide a smart power management capability. The 68EC000 can be put to sleep when no key is being pressed. Once a key is pressed, however, the core wakes up to service your request. This event-driven approach significantly reduces power consumption. $\overline{KB0}$ to $\overline{KB7}$ (muxed with $\overline{INT}[3:0]$, $\overline{IRQ1}$, $\overline{IRQ2}$, $\overline{IRQ3}$, $\overline{IRQ6}$) are input pins for the keyboard interface. They are internally OR'ed together and generate an interrupt that indicates to the core that a key has been pressed.

6.8 PEN INTERRUPTS

The MC68EZ328 is designed to support pen/touch panel inputs. In most of these systems, the setup involves a touch panel connected to an analog-to-digital (A/D) converter and the microprocessor. To achieve low power consumption and system performance, the A/D is usually connected to an interrupt of the microprocessor. When the touch panel is touched, the CPU is activated through the interrupt and the A/D starts collecting data. On the MC68EZ328, $\overline{IRQ5}$ is a level 5 interrupt with pull-up properties that is normally used as a pen interrupt. Connecting the $\overline{IRQ5}$ to a transistor network with the A/D, a pen-down interrupt can be implemented with the MC68EZ328 system. With the special design circuitry inside, this pen interrupt supports both pen-down and pen-up interrupts. The polarity of the pen interrupt can be set by programming the POL5 bit of the interrupt control register.

SECTION 7 PARALLEL PORTS

The MC68EZ328 microprocessor has seven multi-purpose, configurable parallel ports. There are two types of these ports—regular ports and an interrupt port (Port D). This section will describe how to use the ports for external I/O control and to determine the status of the external signals.

7.1 OPERATION

Ports A, B, C, D, E, F and G are programmable parallel ports with pull-up/pull-down capability. Figure 7-1 illustrates how they operate.

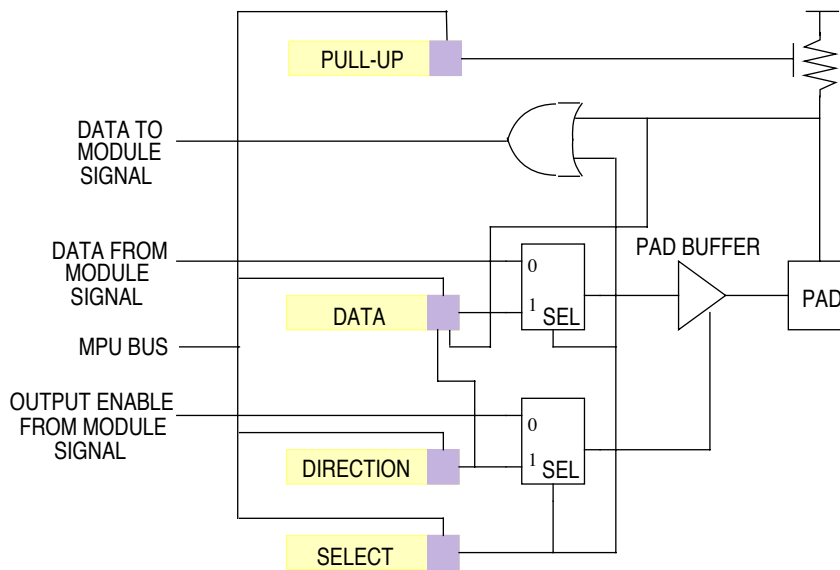

Figure 7-1. Parallel Port Operation

Figure 7-1 illustrates an I/O port that goes to and from a module. For example, for the D0 bit of Port E, the “Data from module” signal is connected to the serial peripheral interface module’s TXD signal. Because this bit is output-only, the “output enable from module” signal is always asserted, which enables the output, and the “data to module” signal in Figure 7-1 is not used. Another example is the D1 bit of Port E, in which this signal’s function is the serial peripheral interface module’s input-only RXD signal. In this case, the “output enable from module” input is negated and the “data from module” signal is not used. The “data to module” signal is connected to the SPMRXD input signal.

Parallel Ports

While the SELx bit of the PxSEL register is clear (the default is set at reset), the module pin function is enabled. Bit D0 of Port E is the master SPMTXD signal. The serial peripheral interface module controls the direction of data flow, which is always output. While the SELx bit is set (if the DIRx bit of the PxDIR is 1), data written to the data register is presented to the pin. If the DIRx bit is 0 (an input), data present on the pin is sampled and presented to the CPU when a read cycle is executed. While the DIRx bit is an output, the actual pin level is presented during read accesses. This may not be the same as the data that was written if the pin is overdriven. To prevent glitches when you change from one mode to another, the intended data should be written to the PxDATA register before you enter the selected mode.

You can enable the pull-up resistor by setting the pull-up register's bits to 1. You can select the pull-up resistors individually and it does not matter if the I/O port is selected or not. After reset, Ports A-F will default to the I/O function with internal pull-up enabled. Meanwhile, Port G will default to the dedicated function, except for the $\overline{\text{HIZ}}/\text{P}/\overline{\text{D}}/\text{PG3}$ pin, which defaults to the PG3 function.

7.2 PROGRAMMING MODEL

7.2.1 Port A Registers

The Port A registers are general-purpose I/O registers. They consist of the following:

- Port A direction register (PADIR)
- Port A data register (PADATA)
- Port A pull-up enable register (PAPUEN)

Port A is multiplexed with data lines D[7:0]. In an 8-bit-only system, you can configure these pins as a parallel I/O port by writing a 1 to the WPTH8 bit of the SCR, which is described in [Section 3.2.1 System Control Register](#). At reset, the data lines are connected to the pins.

PADIR AND PADATA

BIT	15	14	13	12	11	10	9	8	7	6	5	4	3	2	1	0
FIELD	DIR7	DIR6	DIR5	DIR4	DIR3	DIR2	DIR1	DIR0	D7	D6	D5	D4	D3	D2	D1	D0
RESET	0x0000															
ADDR	0xFFFFF400 AND 0x401															

PAPUEN

BIT	15	14	13	12	11	10	9	8	7	6	5	4	3	2	1	0
FIELD	PU7	PU6	PU5	PU4	PU3	PU2	PU1	PU0	RESERVED							
RESET	0xFF00															
ADDR	0xFFFFF402															

DIRx—Direction 7–0

These bits control the direction of the pins in an 8-bit system.

- 0 = The pins are inputs.
- 1 = The pins are outputs.

Dx—Data 7–0

These bits reflect the status of the I/O signal in an 8-bit system.

- 0 = Drive the output signal low when DIRx is set to 1 or the external signal is low when DIRx is set to 0.
- 1 = Drive the output signal high when DIRx is set to 1 or the external signal is high when DIRx is set to 0.

PUx—Pull-Up 7–0

These bits enable the pull-up resistors on the port.

- 0 = Pull-up resistors are disabled.
- 1 = Pull-up resistors are enabled.

Bits 7–0—Reserved

These bits are reserved and should be set to 0.

7.2.2 Port B Registers

The Port B registers are general-purpose I/O registers. They consist of the following:

- Port B direction register (PBDIR)
- Port B data register (PBDATA)
- Port B pull-up enable register (PBPUEEN)
- Port B select register (PBSEL)

Port B is multiplexed with the signals in the following table.

BIT	PORT FUNCTIONS	DEDICATED FUNCTIONS
0	Bit 0	$\overline{CSB0}$
1	Bit 1	$\overline{CSB1}$
2	Bit 2	$\overline{CSC0/RAS0}$
3	Bit 3	$\overline{CSC1/RAS1}$
4	Bit 4	$\overline{CSD0/CAS0}$
5	Bit 5	$\overline{CSD1/CAS1}$
6	Bit 6	TIN/TOUT
7	Bit 7	PWMO

Parallel Ports

All of the signals in the table are implemented in the registers and all of them connect to external pins. As on the other ports, each bit on Port B can be individually configured. Bits 2-5 can function as chip-selects $\overline{CSB}[1:0]$, $\overline{CSC}[1:0]$, and $\overline{CSD}[1:0]$. However, these chip-selects are also multiplexed with DRAM signals $\overline{CAS}[1:0]$ and $\overline{RAS}[1:0]$. You can select these signals by programming the DRAM bit in the CSD register, which is described in [Section 4.2.2 Chip-Select Registers](#). No additional programming is required.

For the TIN/TOUT signal, you can select the peripheral function by programming the PBDIR register. When you select this register as an input, the peripheral function will be TIN. The peripheral function will be TOUT if the PBDIR is programmed as an output.

PBDIR AND PBDATA

BIT	15	14	13	12	11	10	9	8	7	6	5	4	3	2	1	0
FIELD	DIR7	DIR6	DIR5	DIR4	DIR3	DIR2	DIR1	DIR0	D7	D6	D5	D4	D3	D2	D1	D0
RESET	0x0000															
ADDR	0xFFFFF408 AND 0x409															

PBPUEN AND PBSEL

BIT	15	14	13	12	11	10	9	8	7	6	5	4	3	2	1	0
FIELD	PU7	PU6	PU5	PU4	PU3	PU2	PU1	PU0	SEL7	SEL6	SEL5	SEL4	SEL3	SEL2	SEL1	SEL0
RESET	0xFFFF															
ADDR	0xFFFFF40A AND 0x40B															

DIRx—Direction 7–0

These bits control the direction of the pins. They reset to 0 and have no function when the SELx bits are low.

- 0 = The pins are inputs.
- 1 = The pins are outputs.

Dx—Data 7–0

These bits control or report the data on the pins while the associated SELx bits are high. While the DIRx bits are high (output), the PBDIR register's bits control the pins. While the DIRx bits are low (input), the other functions report the signal driving the pins. The Dx bits can be written at any time. Bits that are configured as inputs will accept the data, but you cannot access the written data until you configure their respective pins as outputs. The actual value on the pin is reported when these bits are read, regardless of whether they are configured as input or output.

PUx—Pull-Up 7–0

These bits enable the pull-up resistors on the port.

- 0 = Pull-up resistors are disabled.
- 1 = Pull-up resistors are enabled.

SELx—Select 7–0

These bits allow you to select whether the internal chip function or I/O port signals are connected to the pins.

- 0 = The dedicated function pins are connected.
- 1 = The I/O port function pins are connected.

7.2.3 Port C Registers

The Port C registers are general-purpose I/O registers. They consist of the following:

- Port C direction register (PCDIR)
- Port C data register (PCDATA)
- Port C pull-down enable register (PCPDEN)
- Port C select register (PCSEL)

Port C is multiplexed with the LCD signals in the following table.

BIT	PORT FUNCTIONS	DEDICATED FUNCTIONS
0	Bit 0	LD0
1	Bit 1	LD1
2	Bit 2	LD2
3	Bit 3	LD3
4	Bit 4	LFLM
5	Bit 5	LLP
6	Bit 6	LCLK
7	Bit 7	LACD

All of the signals in the table are implemented in the registers and all of them connect to external pins. As on the other ports, each bit on Port C can be individually configured. Port C is primarily multiplexed with the LCD controller's signals. These pins can be programmed as I/O when you are not using the LCD controller and they can be reclaimed as I/O ports. See for more information.

PCDIR AND PCDATA

BIT	15	14	13	12	11	10	9	8	7	6	5	4	3	2	1	0
FIELD	DIR7	DIR6	DIR5	DIR4	DIR3	DIR2	DIR1	DIR0	D7	D6	D5	D4	D3	D2	D1	D0
RESET	0x0000															
ADDR	0xFFFFF410 AND 0x411															

PCPDEN AND PCSEL

BIT	15	14	13	12	11	10	9	8	7	6	5	4	3	2	1	0
FIELD	PD7	PD6	PD5	PD4	PD3	PD2	PD1	PD0	SEL7	SEL6	SEL5	SEL4	SEL3	SEL2	SEL1	SEL0
RESET	0xFFFF															
ADDR	0xFFFFF412 AND 0x413															

DIRx—Direction 7–0

These bits control the direction of the pins. Because there are no SELx bits associated with Bits 3-0, the I/O function for these bits is always enabled.

- 0 = The pins are inputs.
- 1 = The pins are outputs.

Dx—Data 7–0

These bits control or report the data on the pins while the associated SELx bits are high. While the DIRx bits are high (output), the PCDATA register's bits control the pins. While the DIRx bits are low (input), the other functions report the signal driving the pins. The Dx bits can be written at any time. Bits that are configured as inputs will accept the data, but you cannot access the written data until you configure their respective pins as outputs. The actual value on the pin is reported when these bits are read.

PDx—Pull-Down 7–0

These bits enable the pull-down resistors on the port. The pull-downs are enabled at reset.

- 0 = Pull-down resistors are disabled.
- 1 = Pull-down resistors are enabled.

SELx—Select 7–0

These bits allow you to select whether the internal chip function or I/O port signals are connected to the pins.

- 0 = The internal chip function pins are connected.
- 1 = The I/O port function pins are connected.

7.2.4 Port D Registers

The Port D registers are general-purpose I/O registers. They consist of the following:

- Port D direction register (PDDIR)
- Port D data register (PDDATA)
- Port D pull-up enable register (PDPUEN)
- Port D select register (PDSEL)
- Port D polarity register (PDPOL)
- Port D interrupt request enable register (PDIQEN)
- Port D keyboard enable register (PDKBEN)
- Port D interrupt request edge register (PDIQEG)

Port D is an interrupt port with the same functionality of a regular port, except it also has interrupt capabilities. Figure 7-2 illustrates how this type of port operates.

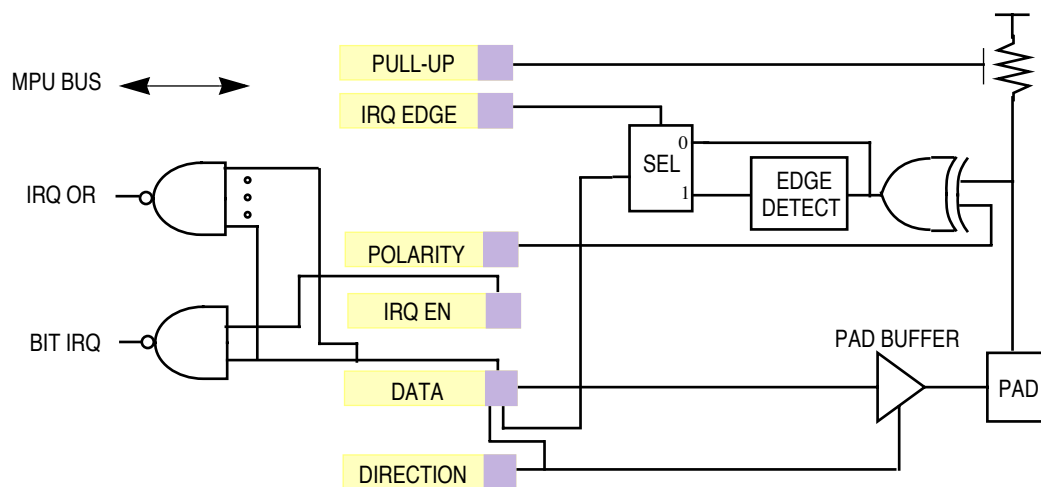

Figure 7-2. Interrupt Port Operation

Port D only has interrupt signals and it has both programmable I/O and interrupt functionality. It should be used as a general-purpose, interrupt-generating port or as a keyboard input port. The $\overline{INT}[3:0]$ signals are all level 4 interrupts, but \overline{IRQx} has its own level. Port D generates nine interrupt signals. Eight of these interrupts are generated by the bits of each port and one is the logical-OR of all eight bits.

The individual interrupt bits can be masked on a bit-by-bit basis. You must enable or disable the OR interrupt in the KBEN bit of the PDKBEN register. You can configure the individual

Parallel Ports

interrupts to be edge- or level-sensitive in the IQEGx bits of the PDIQEG register and you can select the polarity in the POLx bits of the PDPOL register.

BIT	PORT FUNCTIONS	DEDICATED FUNCTIONS
0	Bit 0	$\overline{\text{INT0}}$
1	Bit 1	$\overline{\text{INT1}}$
2	Bit 2	$\overline{\text{INT2}}$
3	Bit 3	$\overline{\text{INT3}}$
4	Bit 4	$\overline{\text{IRQ1}}$
5	Bit 5	$\overline{\text{IRQ2}}$
6	Bit 6	$\overline{\text{IRQ3}}$
7	Bit 7	$\overline{\text{IRQ6}}$

All of the interrupt signals in the table can be used as system wake-up interrupts, except for the edge interrupt on $\overline{\text{INT}}[3:0]$. Edge interrupts on $\overline{\text{INT}}[3:0]$ can only interrupt the CPU when the system is awake. Any combination of Port D signals and OR (negative logic) can be selected to generate keyboard (KB) interrupts to the CPU. The $\overline{\text{KBx}}$ signal is an active low, level-sensitive interrupt of the selected pins. Like the other ports, each pin can be configured as an input or output on a bit-by-bit basis. When they are configured as inputs, each pin can generate a CPU interrupt.

PDDIR AND PDDATA

BIT	15	14	13	12	11	10	9	8	7	6	5	4	3	2	1	0
FIELD	DIR7	DIR6	DIR5	DIR4	DIR3	DIR2	DIR1	DIR0	D7	D6	D5	D4	D3	D2	D1	D0
RESET	0xFFFF0															
ADDR	0xFFFFF418 AND 0x419															

PDPUEN AND PDSEL

BIT	15	14	13	12	11	10	9	8	7	6	5	4	3	2	1	0
FIELD	PU7	PU6	PU5	PU4	PU3	PU2	PU1	PU0	SEL7	SEL6	SEL5	SEL4	–	–	–	–
RESET	0xFFFF0															
ADDR	0xFFFFF41A AND 0x41B															

PDPOL AND PDIRQEN

BIT	15	14	13	12	11	10	9	8	7	6	5	4	3	2	1	0
FIELD	–	–	–	–	POL3	POL2	POL1	POL0	–	–	–	–	IQEN3	IQEN2	IQEN1	IQEN0
RESET	0x00000															
ADDR	0xFFFFF41C AND 0x41D															

PDKBEN AND PDIQEG

BIT	15	14	13	12	11	10	9	8	7	6	5	4	3	2	1	0
FIELD	KBEN7	KBEN6	KBEN5	KBEN4	KBEN3	KBEN2	KBEN1	KBEN0	–	–	–	–	IQEG3	IQEG2	IQEG1	IQEG0
RESET	0x0000															
ADDR	0xFFFFF41E AND 0x41F															

DIRx—Direction 7–0

These bits control the direction of the pins. Because there are no SELx bits associated with Bits 3–0, the I/O function is always enabled for DIRx.

- 0 = The pins are inputs.
- 1 = The pins are outputs.

Dx—Data 7–0

These bits control or report the data on the pins. While the DIRx bits are high (output), the Dx bits control the data to the pins. While the DIRx bits are low (input), the Dx bits report the signal driving the pins. Bits that are configured as inputs will accept the data, but you cannot access the written data until you configure their respective pins as outputs. The actual value on the pin is reported when these bits are read. Bits that are configured as edge-sensitive interrupts will be read as 1 when an edge is detected. The Dx bits are reset to 0 when the DIRx bits are low.

PUx—Pull-Up 7–0

These bits enable the pull-up resistors on the port. The pull-ups are enabled at reset.

- 0 = Pull-up resistors are disabled.
- 1 = Pull-up resistors are enabled.

Parallel Ports

SELx—Select 7–4

These bits allow you to select whether the interrupt or port I/O signals are connected to the pins.

- 0 = The interrupt pins are connected.
- 1 = The port I/O function pins are connected.

POLx—Polarity 3–0

These bits select the input signal polarity of $\overline{\text{INT}}[3:0]$. Interrupts are active high (or rising edge) while these bits are low. Interrupts are active low (or falling edge) while these bits are high.

- 0 = Data is unchanged.
- 1 = The input data is inverted before being presented to the holding register.

IQENx—Interrupt Enable 3–0

These bits allow you to select the $\overline{\text{INT}}[3:0]$ pins that you want to present to the interrupt controller. This allows pins to use the I/O function, but still have interrupt capability.

IQEGx—Edge Enable 3–0

The polarity of the rising or falling edge is selected by the POLx bits. However, edge interrupt for $\overline{\text{INT}}[3:0]$ cannot be used for system wake-up. You have to select level-sensitive instead.

- 0 = Level-sensitive interrupts are selected.
- 1 = $\overline{\text{INT}}[3:0]$ edge-sensitive interrupts are selected.

KBENx—Keyboard Enable 7–0

All the selected signals are active low in reference to the external pins and those that are asserted will generate a keyboard interrupt to the interrupt controller. When a KBENx bit is selected, the DIRx bits need to be configured as an input. The SELx, POLx, IQENx, and IQEGx bits have no effect on the functionality of KBENx. Deasserting the interrupt source is the only way to clear a keyboard interrupt.

- 0 = The keyboard interrupt is disabled.
- 1 = The keyboard interrupt is enabled.

7.2.5 Port E Registers

The Port E registers are general-purpose I/O registers. They consist of the following:

- Port E direction register (PEDIR)
- Port E data register (PEDATA)
- Port E pull-up enable register (PEPUEN)
- Port E select register (PESEL)

Port E is multiplexed with the serial peripheral interface and UART signals described in the following table.

BIT	PORT FUNCTIONS	DEDICATED FUNCTIONS
0	Bit 0	SPMTXD
1	Bit 1	SPMRXD
2	Bit 2	SPMCLK
3	Bit 3	\overline{DWE}
4	Bit 4	RXD
5	Bit 5	TXD
6	Bit 6	\overline{RTS}
7	Bit 7	\overline{CTS}

All of the bits in the table are implemented in the registers and all of them connect to external pins. As on the other ports, each bit on Port E can be individually configured.

PEDIR AND PEDATA

BIT	15	14	13	12	11	10	9	8	7	6	5	4	3	2	1	0
FIELD	DIR7	DIR6	DIR5	DIR4	DIR3	DIR2	DIR1	DIR0	D7	D6	D5	D4	D3	D2	D1	D0
RESET	0x0000															
ADDR	0xFFFFF420 AND 0x421															

PEPUEN AND PESEL

BIT	15	14	13	12	11	10	9	8	7	6	5	4	3	2	1	0
FIELD	PU7	PU6	PU5	PU4	PU3	PU2	PU1	PU0	SEL7	SEL6	SEL5	SEL4	SEL3	SEL2	SEL1	SEL0
RESET	0xFFFF															
ADDR	0xFFFFF422 AND 0x423															

DIRx—Direction 7–0

These bits control the direction of the pins. They reset to 0 and have no function when the SELx bits are low.

- 0 = The pins are inputs.
- 1 = The pins are outputs.

Parallel Ports

Dx—Data 7–0

These bits control or report the data on the pins while the associated SELx bits are high. While the DIRx bits are high (output), the PEDATA register's bits control the pins. While the DIRx bits are low (input), the Dx bits report the signal level on the pins. Bits that are configured as inputs will accept the data, but you cannot access the written data until you configure their respective pins as outputs. The actual value on the pin is reported when these bits are read, regardless of whether they are input or output. The Dx bits reset to 0.

PUx—Pull-Up 7–0

These bits enable the pull-up resistors on the port. PU7 is enabled at reset.

- 0 = Pull-down resistors are disabled.
- 1 = Pull-down resistors are enabled.

SELx—Select 7–0

These bits allow you to select whether the internal chip function or I/O port signals are connected to the pins.

- 0 = The internal chip function pins are connected.
- 1 = The I/O port function pins are connected.

7.2.6 Port F Registers

The Port F registers are general-purpose I/O registers. They consist of the following:

- Port F direction register (PFDIR)
- Port F data register (PFDATA)
- Port F pull-up enable register (PFPUEN)
- Port F select register (PFSEL)

Port F is multiplexed with address lines A[20:23] and dedicated functions, as shown in the following table. Unused address pins can serve as parallel I/Os on a bit-by-bit basis.

BIT	PORT FUNCTIONS	DEDICATED FUNCTIONS
0	Bit 0	LCONTRAST
1	Bit 1	$\overline{\text{IRQ5}}$
2	Bit 2	CLKO
3	Bit 3	A20
4	Bit 4	A21
5	Bit 5	A22
6	Bit 6	A23
7	Bit 7	$\overline{\text{CSA1}}$

PFDIR AND PFDATA

BIT	15	14	13	12	11	10	9	8	7	6	5	4	3	2	1	0
FIELD	DIR7	DIR6	DIR5	DIR4	DIR3	DIR2	DIR1	DIR0	D7	D6	D5	D4	D3	D2	D1	D0
RESET	0x0000															
ADDR	0xFFFFF428 AND 0x429															

PFPUEN AND PFSEL

BIT	15	14	13	12	11	10	9	8	7	6	5	4	3	2	1	0
FIELD	PU7	PD6	PD5	PD4	PD3	PU2	PU1	PU0	SEL7	SEL6	SEL5	SEL4	SEL3	SEL2	SEL1	SEL0
RESET	0xFFFF															
ADDR	0xFFFFF42A AND 0x42B															

DIRx—Direction 7–0

These bits control the direction of the pins. They reset to 0 and have no function when the SELx bits are low.

- 0 = The pins are inputs.
- 1 = The pins are outputs.

Dx—Data 7–0

These bits control or report the data on the pins while the associated SELx bits are high. While the DIRx bits are high (output), the Dx bits control the data to the pins. While the DIRx bits are low (input), the Dx bits report the signal driving the pins. Bits that are configured as inputs will accept the data, but you cannot access the written data until you configure their respective pins as outputs. The actual value on the pin is reported when these bits are read, regardless of whether they are input or output. The Dx bits reset to 0.

PUx—Pull-Up 7 and 2–0

These bits enable the pull-up resistors at reset on the port.

- 0 = Pull-up resistors are disabled.
- 1 = Pull-up resistors are enabled.

PDx—Pull-Down 6–3

These bits enable the pull-down resistors at reset on the port.

- 0 = Pull-down resistors are disabled.
- 1 = Pull-down resistors are enabled.

Parallel Ports

SELx—Select 7–0

These bits allow you to select whether the internal chip function or I/O port signals are connected to the pins. The I/O function is selected at reset.

0 = The internal chip function pins are connected.

1 = The I/O port function pins are connected.

7.2.7 Port G Registers

The Port G registers are general-purpose I/O registers. They consist of the following:

- Port G direction register (PGDIR)
- Port G data register (PGDATA)
- Port G pull-up enable register (PGPUEN)
- Port G select register (PGSEL)

Port G is a special port that is multiplexed with emulator pins and other functions, which are shown in the following table.

BIT	PORT FUNCTION	DEDICATED FUNCTIONS
0	Bit 0	BUSW/DTACK
1	Bit 1	A0
2	Bit 2	EMUIRQ
3	Bit 3	HIZ/P/D
4	Bit 4	EMUCS
5	Bit 5	EMUBRK
6	Bit 6	—
7	Bit 7	—

You can use Port G as an I/O pin, but you should do so with caution. After reset, the Port G pins will default to the dedicated function, except Bit 3, which has an I/O function. To ensure normal operation, the EMUIRQ and EMUBRK pins must stay high or not be connected during system reset. Otherwise, the chip will enter emulation mode. When Bits 2-5 are used as I/O, the emulation mode cannot be used. On the other hand, if you want to use emulation mode for development and Bits 2-5 as I/O in the final system, these pins cannot be emulated. A0 can be used as I/O when the system is 16-bit and there is no pull-up after reset for this pin.

PGDIR AND PGDATA

BIT	15	14	13	12	11	10	9	8	7	6	5	4	3	2	1	0
FIELD	–	–	DIR5	DIR4	DIR3	DIR2	DIR1	DIR0	–	–	D5	D4	D3	D2	D1	D0
RESET	0x0000															
ADDR	0xFFFFF430 AND 0x431															

PGPUEN AND PGSEL

BIT	15	14	13	12	11	10	9	8	7	6	5	4	3	2	1	0
FIELD	–	–	PU5	PU4	PU3	PU2	PU1	PU0	–	–	SEL5	SEL4	SEL3	SEL2	SEL1	SEL0
RESET	0x3D08															
ADDR	0xFFFFF432 AND 0x433															

DIRx—Direction 5–0

These bits control the direction of the pins. They reset to 0 and have no function when the SELx bits are low.

- 0 = The pins are inputs.
- 1 = The pins are outputs.

Dx—Data 5–0

These bits control or report the data on the pins while the associated SELx bits are high. While the DIRx bits are high (output), the Dx bits control the data to the pins. While the DIRx bits are low (input), the Dx bits report the signal driving the pins. Bits that are configured as inputs will accept the data, but you cannot access the written data until you configure their respective pins as outputs. The actual value on the pin is reported when these bits are read, regardless of whether they are input or output. The Dx bits reset to 0.

PUx—Pull-Up 5–0

These bits enable the pull-up resistors at reset on the port.

- 0 = Pull-up resistors are disabled.
- 1 = Pull-up resistors are enabled.

Parallel Ports

SELx—Select 5–0

These bits allow you to select whether the internal chip function or I/O port signals are connected to the pins.

0 = The internal chip function pins are connected.

1 = The I/O port function pins are connected.

SECTION 8

PULSE-WIDTH MODULATOR

The pulse-width modulator (PWM) of the MC68EZ328 is optimized to generate high-quality sound from stored sample audio images and it can also generate tones. It uses 8-bit resolution and a 5-byte FIFO to generate sound. Figure 8-1 illustrates the block diagram of the pulse-width modulator.

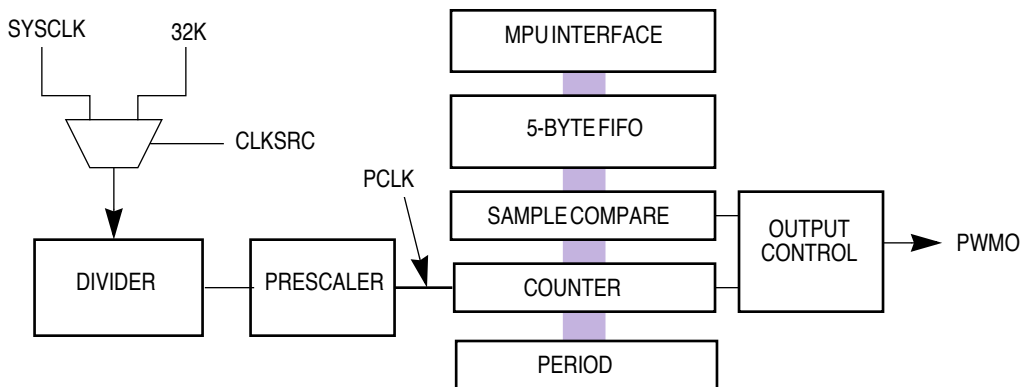

Figure 8-1. Pulse-Width Modulator Block Diagram

8.1 OPERATION

The pulse-width modulator has three modes of operation—playback, tone, and D/A.

8.1.1 Playback Mode

In playback mode, the pulse-width modulator uses the data from your sound file to output a sound through your speaker. However, to produce the sound, you must use the same frequency that you used to record the sound. It produces variable-width pulses at a constant frequency. The width of the pulse is proportional to the analog voltage of a particular audio sample. At the beginning of a sample period cycle, the PWMO pin is set to one and the counter begins counting up from 0x00. The sample value is compared on each count or prescaler clock. When the sample and count values match, the PWMO signal is cleared to zero. The counter continues counting and when it overflows from 0xFF to 0x00, another sample period cycle begins. The prescaler clock (PCLK) runs 256 times faster than the reconstruction rate when the PERIOD field of the PWMP register is at its maximum value. So for 16kHz reconstruction, PCLK is 4.096MHz. For human voice quality sound, the reconstruction frequency is either 8 or 16kHz. Figure 8-2 illustrates how variable width pulses affect an audio waveform.

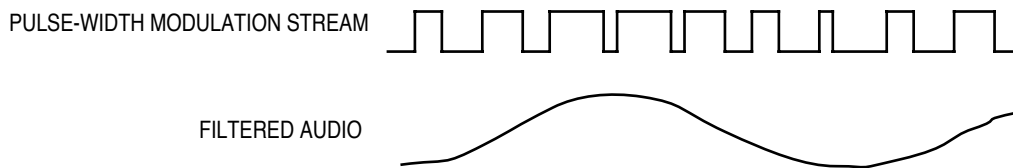

Figure 8-2. Audio Waveform Generation

Digital sample values can be loaded into the pulse-width modulator either as packed 2-sample 16-bit words (big endian format) or as individual 8-bit bytes. A 5-byte FIFO minimizes interrupt overhead. A maskable interrupt is generated when there are 1 or 0 bytes in the FIFO, in which case, the software can write either 4-byte samples or two 2-sample words into the FIFO. When you use a 16kHz reconstruction frequency and write four bytes at each interrupt, interrupts occur at 50µsec intervals if you set the REPEAT field of the PWMC register to 01.

8.1.2 Tone Mode

In tone mode, the pulse-width modulator generates a continuous tone at a single frequency if you program the PWM registers. The prescaler and divider generate the PCLK signal. You can program the 7-bit prescaler with any number between 0 and 127, which scales down incoming clocks from 1 to 128, respectively. The variable divider can divide the incoming clock source by a binary value that is between 2 and 16. 16kHz audio applications will use the prescaler, which is set to 0, at divide by 4. DC-level applications will use the prescaler, which is set to 0, at divide by 16.

8.1.3 D/A Mode

The pulse-width modulator can output a frequency with a different pulse-width if you add a low-pass filter at the PWMO signal. It produces a different DC level when you program the PWMS register. It then becomes a D/A converter.

8.2 PROGRAMMING MODEL

8.2.1 PWM Control Register

The pulse-width modulator control register (PWMC) controls how the overall pulse-width modulator operates. You can also find out the status of the FIFO with this register.

PWMC

BIT	15	14	13	12	11	10	9	8	7	6	5	4	3	2	1	0
FIELD	CLK SRC	PRESCALER						IRQ	IRQ EN	FIFO AV	EN	REPEAT	CLKSEL			
RESET	0x0020															
ADDR	0x(FF)FFF500															

CLKSRC—Clock Source

This bit is used to select the clock source to the pulse-width modulator.

- 0 = A system clock source is selected (default).
- 1 = A 32.768kHz clock source is selected if you are using a 32.768kHz crystal. If you are using a 38.4kHz crystal, 38.4kHz is selected.

PRESCALER

This field is used to scale down the incoming clock to divide by the prescaler+1. The prescaler is normally used to generate a low single-tone PWMO signal. For voice modulation, these bits are set to 0 (divide by 1). The default value is 0.

IRQ—Interrupt Request

This bit indicates that the FIFO has one or no bytes remaining, which can be a signal to you that you need to fill the FIFO by writing no more than two 16-bit words into the PWMS register. This bit automatically clears itself after this register is read, thus eliminating an extra write cycle in the interrupt service routine. If the IRQEN bit is 0, this bit can be polled to indicate the status of the period comparator. You can set this bit to immediately post a PWM interrupt for debugging purposes.

- 0 = The FIFO is not empty.
- 1 = The FIFO has one or no sample bytes remaining.

IRQEN—Interrupt Request Enable

This bit controls the pulse-width modulator interrupt. While this bit is low, the interrupt is disabled.

- 0 = The PWM interrupt is disabled (default).
- 1 = The PWM interrupt is enabled.

FIFOAV—FIFO Available

This bit indicates that the FIFO is available for at least one byte of sample data. Data bytes can be loaded into the FIFO as long as this bit is set. If the FIFO is loaded while this bit is cleared, the write will be ignored.

Pulse-Width Modulator

EN—Enable

This bit enables the pulse-width modulator. If this bit is not enabled, writing to other pulse-width modulator registers is ignored.

- 0 = The pulse-width modulator is disabled (default).
- 1 = The pulse-width modulator is enabled.

When the pulse-width modulator is disabled, it is in low-power mode, the output pin is forced to 0, and the following events occur.

- The clock prescaler is reset and frozen.
- The counter is reset and frozen.
- The FIFO is flushed.

When the pulse-width modulator is enabled, it begins a new period, and the following events occur.

- The output pin is set to start a new period.
- The prescaler and counter are released and begin counting.
- The IRQ bit is set, thus indicating that the FIFO is empty.

REPEAT—Sample Repeats

These write-only bits select the number of times each sample is repeated.

- 00 = No samples are repeated (play the sample once). Default.
- 01 = Repeat one time (play the sample twice).
- 10 = Repeat three times (play the sample four times).
- 11 = Repeat seven times (play the sample eight times).

The repeat feature reduces the interrupt overhead when audio data is reconstructed at a higher rate and, thus, enables you to use a lower cost low-pass filter. For example, if the audio data is sampled at 8kHz and the data is reconstructed at 8kHz again, you will hear an 8kHz humming noise. To filter this carrier, you need a high-quality low-pass filter. For a higher reconstruction rate, you can reconstruct samples at 16kHz and use the sample twice. This method will shift the carrier from an audible 8kHz to a less-sensitive 16kHz frequency. This feature can reduce CPU loading and software overhead on a higher reconstruction rate.

CLKSEL—Clock Selection

This field selects the output of the divider chain.

- 00 = Divide by 2. Provides an approximate 32kHz reconstruction rate (default).
- 01 = Divide by 4. Provides an approximate 16kHz reconstruction rate.
- 10 = Divide by 8. Provides an approximate 8kHz reconstruction rate.
- 11 = Divide by 16. Provides an approximate 4kHz reconstruction rate.



Note: The approximate reconstruction rates are calculated using a 16MHz clock source (PRESCALER = 0 and PERIOD = default).

8.2.2 PWM Sample Register

The pulse-width modulator sample (PWMS) register is the input to the FIFO. When you write successive audio sample values to this register, they are automatically loaded into the FIFO in big-endian format. 16-bit words are loaded into the 8-bit FIFO high-bytes, then low-bytes. When you write individual sample-bytes, they must be written to the low byte (SAMPLE1). The pulse-width modulator will free-run at the last set duty-cycle setting until the FIFO is reloaded or the pulse-width modulator is disabled. If the value in this register is higher than the PERIOD + 1, the output will never be reset, which results in a 100% duty-cycle.

PWMS

BIT	15	14	13	12	11	10	9	8	7	6	5	4	3	2	1	0
FIELD	SAMPLE0								SAMPLE1							
RESET	0xFFFF															
ADDR	0xFF502															

SAMPLE0

This field represents the high byte of a two-sample word. This byte will be presented to the pulse-width modulator before the SAMPLE1 field.

SAMPLE1

This field represents the low byte of a two-sample word. This byte will be presented to the pulse-width modulator after the SAMPLE0 field. When used with single 8-bit samples, data must be written to this byte.

8.2.3 PWM Period Register

The read/write pulse-width modulator period (PWMP) register controls the pulse-width modulator period. When the counter value matches PERIOD +1, the counter is reset to start

another period. Therefore, PWMO (Hz) = PCLK(Hz) / (period +2). Writing 0xFF to this register will achieve the same result as writing 0xFE.

PWMP

BIT	7	6	5	4	3	2	1	0
FIELD	PERIOD							
RESET	0xFE							
ADDR	0x(FF)FFF504							

PERIOD

This field represents the pulse-width modulator's period control value.

8.2.4 PWM Counter Register

The read-only pulse-width modulator counter (PWMCNT) register contains the current count value and can be read at any time without disturbing the counter.

PWMCNT

BIT	7	6	5	4	3	2	1	0
FIELD	COUNT							
RESET	0x0000							
ADDR	0x(FF)FFF505							

COUNT

This field represents the current count value.

8.3 PROGRAMMING EXAMPLE

The following software code demonstrates how you can take advantage of the pulse-width modulator's FIFO.

```

/* Global Variables and Registers */
volatile unsigned char *PWMControl = 0xffff501;
volatile unsigned short *PWMSample = 0xffff502;
volatile unsigned long *IRQMaskReg = 0xffff304;
unsigned short *next_PWM_sample_pair; // ptr into sample buffer
unsigned long PWM_buffer_size; // measured in words
    
```

```

#define PWMIRQ0x00000080
#define PWM_IRQ_ENABLE 0x40
#define PWM_ENABLE 0x10
#define PWM32KHZ0x00
    
```

```

#define PWM16KHZ0x01
#define PWM8KHZ0x02
#define PWM4KHZ0x03

// Initialization Routine
// Initialize the audio sample buffer and get the PWM block
// started. It is assumed that the PWMO pin is already properly configured.
void
InitializeAudio(
unsigned short *sample_array,
unsigned long num_samples
) {

    // set up pointer to audio sample buffer
    next_PWM_sample_pair = sample_array;
    PWM_buffer_size = num_samples;

    // turn on the PWM
    // enable the interrupt
    // set prescaler for 16 kHz operation
    // and load initial 4 sample values into the FIFO
    *PWMControl = PWM_ENABLE | PWM_IRQ_ENABLE | PWM16KHZ;

    // enable interrupt in IRQ Block
    *IRQMaskReg &= ~PWMIRQ;
}

// Interrupt Service Routine
// It is assumed that the OS portion of the interrupt service
// routine has already determined that the PWM is the source
// of this interrupt, then control is transferred here
void
PWM_IRQ_Service() {
    volatile charstatus;

    // read the PWMControl register to clear the IRQ
    status = *PWMControl;

    // load the next 4 sample bytes into the FIFO
    *PWMSample = *next_PWM_sample_pair++;
    if(--PWM_buffer_size == 0)
        *PWMControl = 0x00;
    *PWMSample = *next_PWM_sample_pair++;
    PWM_buffer_size = PWM_buffer_size - 2;
    if(--PWM_buffer_size <= 0)
        *PWMControl = 0x00;
}

```

SECTION 9 GENERAL-PURPOSE TIMER

This section describes how to configure the 16-bit general-purpose timer for your design. The timer can automatically generate an interrupt, it has 60ns resolution for a 16.67MHz system clock, and it has its own I/O pin. Figure 9-1 illustrates the timer's block diagram.

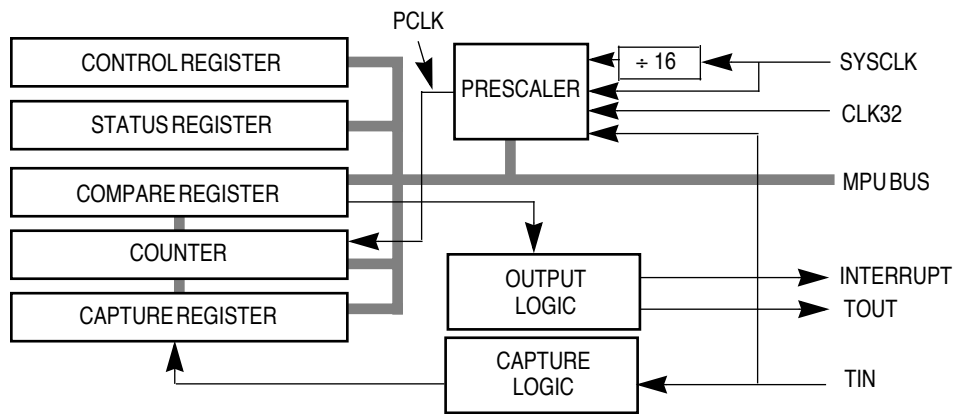

Figure 9-1. General-Purpose Timer Block Diagram

The timer has the following features:

- Maximum period of 524 seconds at 32kHz or 436 seconds at 38.4kHz
- 60ns resolution at 16.67MHz
- Programmable sources for the clock input, including external clock
- Input capture capability with programmable trigger edge
- Output compare with programmable mode
- Free-run and restart modes

9.1 OPERATION

The clock that feeds the prescaler can be selected from the main clock (divided by 1 or by 16), from the timer I/O pin (TIO), or from the 32kHz clock (CLK32). The clock input source is determined by the CLKSOURCE field of the timer control register. The timer prescaler register is used to select the divide ratio of the input clock that drives the main counter. The prescaler can divide the input clock by a value between 1 and 256. While CLK32 is selected as the clock source, the timer operates even while the PLL is in sleep mode.

The timer can be configured for free-run or restart modes by programming the FRR bit of the timer control register. In restart mode, once the compare value is reached, the counter resets to 0x0000, the COMP bit of the timer status register is set, an interrupt is issued if the IRQEN bit of the timer control register is set, and then it resumes counting. This mode is useful when you need to generate periodic events or audio tones when it is used with the timer output signals. In free-run mode, the compare function operates the same as it does in restart mode, but the counter continues counting without resetting to 0x0000. When 0xFFFF is reached, the counter rolls over to 0x0000 and keeps counting.

The timer has a 16-bit capture register that takes a “snapshot” of the counter when a defined transition of TIN is detected by the capture edge detector. The type of transition that triggers this capture is selected by the CAP field of the timer control register. Pulses that produce the capture edge can be as short as 20ns. The minimum time between pulses is two PCLK periods.

When a capture or reference event occurs, the corresponding status bit is set in the timer status register and an interrupt is posted if the capture function is enabled or if the IRQEN bit of the timer control register is set. The timer is disabled at reset.

The timer’s pins are multiplexed with Bit 6 of the Port B registers, which are described in [Section 7.2.2 Port B Registers](#). TOUT/TIN/PB6 is a bidirectional pin. When it is an input, this pin can be used as a clock input to the timer or it can be used as the capture pulse input. When it is an output, this pin can toggle or output a pulse when a timer compare event occurs.

9.2 PROGRAMMING MODEL

9.2.1 Timer Control Register

The timer control (TCTL) register controls the overall operation of the timer.

TCTL

BIT	15	14	13	12	11	10	9	8	7	6	5	4	3	2	1	0
FIELD	RESERVED							FRR	CAP		OM	IRQ EN	CLKSOURCE			TEN
RESET	0x0000															
ADDR	0x(FF)FFF600															

Bits 15–9—Reserved

These bits are reserved and read 0.

FRR—Free-Run/Restart

This bit controls how the timer operates after a capture event occurs. In free-run mode, the timer continues running. In restart mode, the counter resets to 0x0000, then resumes counting.

- 0 = Restart mode.
- 1 = Free-run mode.

CAP—Capture Edge

This field controls the operation of the capture function. The DIRx bit in the corresponding port register must be set to 0 for the capture function to operate correctly. Refer to for more information.

- 00 = Disable the capture function.
- 01 = Capture on the rising edge and generate an interrupt.
- 10 = Capture on the falling edge and generate an interrupt.
- 11 = Capture on the rising or falling edges and generate an interrupt.

OM—Output Mode

This bit controls the output mode of the timer after a reference-compare event occurs. If the CAP field is not set to 00, this bit has no function.

- 0 = Active-low pulse for one SYSCLK period.
- 1 = Toggle output.

IRQEN—Interrupt Request Enable

This bit enables an interrupt on a compare event.

- 0 = Disable the compare interrupt.
- 1 = Enable the compare interrupt.

CLKSOURCE—Clock Source

This field controls the source of the clock to the prescaler. The stop-count freezes the timer at its current value.

- 000 = Stop count (clock disabled).
- 001 = SYSCLK to prescaler.
- 010 = SYSCLK divided by 16 to prescaler.
- 011 = TIN to prescaler.
- 1xx = 32kHz clock to prescaler.

TEN—Timer Enable

This bit enables the general-purpose timer.

- 0 = Timer is disabled (counter reset to 0x0000).
- 1 = Timer is enabled.

9.2.2 Timer Prescaler Register

The timer prescaler register (TPRER) controls the divide value of the prescaler.

TPRER

BIT	15	14	13	12	11	10	9	8	7	6	5	4	3	2	1	0
FIELD	UNUSED								PRESCALER							
RESET	0x0000															
ADDR	0x(FF)FFF602															

Bits 15–8—Reserved

These bits are reserved and read 0.

PRESCALER

This field determines the division value of the prescaler between 1 and 256. 0x00 divides by 1 and 0xFF divides by 256.

9.2.3 Timer Compare Register

The timer compare (TCMP) register contains the value that is compared with the free-running counter. A compare event is generated when the counter matches the value in this register. This register is set to 0xFFFF at system reset.

TCMP

BIT	15	14	13	12	11	10	9	8	7	6	5	4	3	2	1	0
FIELD	COMPARE VALUE															
RESET	0xFFFF															
ADDR	0x(FF)FFF604															

COMPARE VALUE

Write this field’s value to generate a compare event when the counter matches this value.

9.2.4 Timer Capture Register

The timer capture register (TCR) stores the counter value when a capture event occurs.

TCR

BIT	15	14	13	12	11	10	9	8	7	6	5	4	3	2	1	0
FIELD	CAPTURE VALUE															
RESET	0x0000															
ADDR	0x(FF)FFF606															

CAPTURE VALUE

This field stores the counter value that existed at the time of the capture event.

9.2.5 Timer Counter Register

The read-only timer counter (TCN) register can be read at anytime without disturbing the current count.

TCN

BIT	15	14	13	12	11	10	9	8	7	6	5	4	3	2	1	0
FIELD	COUNT															
RESET	0x0000															
ADDR	0x(FF)FFF608															

COUNT

This field contains the current count value.

9.2.6 Timer Status Register

The timer status (TSTAT) register indicates the timer’s status. When a capture event occurs, it is indicated by setting the CAPT bit. When a compare event occurs, the COMP bit is set. You must clear these bits by writing 0 to clear the interrupt, if it is enabled. These bits are cleared by writing 0x0 and will clear only if they have been read while set. This ensures that an interrupt will not be missed if it occurs between the status read and the interrupt cleared.

TSTAT

BIT	15	14	13	12	11	10	9	8	7	6	5	4	3	2	1	0
FIELD	UNUSED														CAPT	COMP
RESET	0x0000															
ADDR	0x(FF)FFF60A															

CAPT—Capture Event

This bit indicates when a capture event occurs.

- 0 = No capture event occurred.
- 1 = A capture event has occurred.

COMP—Compare Event

This bit indicates when a compare event occurs.

- 0 = No compare event occurred.
- 1 = A compare event has occurred.

SECTION 10 SERIAL PERIPHERAL INTERFACE MASTER

This section discusses how the serial peripheral interface master (SPIM) can be used to communicate with external devices, such as EEPROMs, analog-to-digital converters, and other peripherals. The serial peripheral interface master is a 3- or 4-wire system, depending on whether you are in unidirectional or bidirectional communication mode. It provides the clock for data transfer and can only function as a master device. It is fully compatible with the serial peripheral interface on Motorola's 6805 and 68HC11 microprocessors.

Figure 10-1 illustrates the serial peripheral interface master's block diagram.

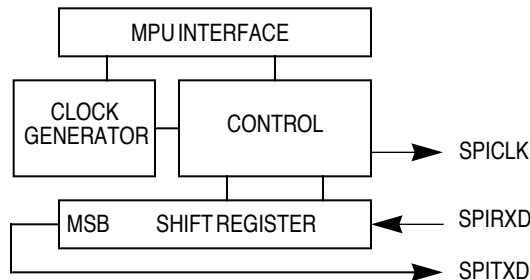

Figure 10-1. Serial Peripheral Interface Master Block Diagram

10.1 OPERATION

The serial peripheral interface master uses a serial link to transfer data between the MC68EZ328 and a peripheral device. An enable and clock signal are used to transfer data between the two devices. If the external device is a transmit-only device, the serial peripheral interface master's output port can be ignored and used for other purposes.

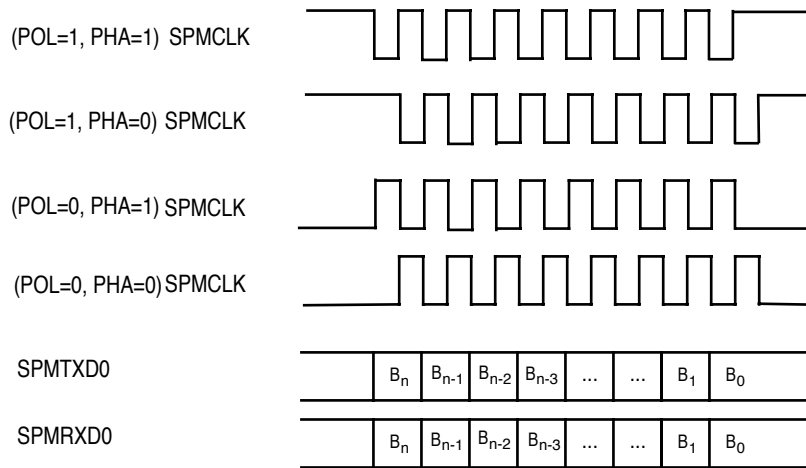

Figure 10-2. Serial Peripheral Interface Master Operation

The serial peripheral interface master pins are multiplexed with Bits 2–0 of the Port E registers, so when you use the serial peripheral interface master, you must write 000 to these bits in the PESEL register. See [Section 7.2.5 Port E Registers](#) for more information.

The serial peripheral interface master does not consume any power when it is disabled. You must enable the ENABLE bit in the SPIMCONT register before you can change any other bits. To perform a serial data transfer, set the ENABLE bit, then, in a separate write cycle, set the appropriate control bits. The serial peripheral interface master is then ready to accept data into the SPIMDATA register, which cannot be written while the serial peripheral interface master is disabled or busy. Once the data is loaded, the XCH bit is set in the SPIMCONT register, which triggers an exchange. The XCH bit remains set until the transfer is complete. If you clear the MSPI bit in the interrupt mask register before you trigger an exchange, an interrupt will be posted when the exchange is complete. See [Section 6.6.3 Interrupt Mask Register](#) for more information. You can find out the status of the interrupt in the IRQ bit of the SPIMCONT register and you can clear this bit by writing a 0 to it.

For systems that need more than 16 clocks to transfer data, the ENABLE bit can remain asserted between exchanges. The enable signal required by some SPI slave devices should be provided by an I/O port pin.

10.1.1 Phase/Polarity Configurations

The serial peripheral interface master uses the SPMCLK signal to transfer data in and out of the shift register. Data is clocked using any one of four programmable clock phase and polarity variations. In Phase 0 operation, output data changes on the falling clock edges and input data is shifted in on rising edges. The most-significant bit is output when the CPU loads the transmitted data. In Phase 1 operation, output data changes on the rising edges of the clock and is shifted in on falling edges. The most-significant bit is output on the first rising SPMCLK edge. Polarity inverts SPMCLK, but does not change the edge-triggered events

that are internal to the serial peripheral interface master. This flexibility allows it to operate with most serial peripheral devices on the market.

10.1.2 Signals

The following signals are used to control the serial peripheral interface master:

- SPMTXD—The Transmit Data pin, which is multiplexed with PE0, is the output of the shift register. A new data bit is presented, but it depends on whether you have selected phase or polarity.
- SPMRXD—The Receive Data pin, which is multiplexed with PE1, is the input to the shift register. A new bit is shifted in, but it depends on whether you have selected phase or polarity.
- SPMCLK—The Clock pin, which is multiplexed with PE2, is the clock output. When the serial peripheral interface master is triggered, the selected number of clock pulses are issued. In Polarity 0 mode, this signal is low while the serial peripheral interface master is idle and high in Polarity 1 mode.

10.2 PROGRAMMING MODEL

10.2.1 SPIM Data Register

The serial peripheral interface master data (SPIMDATA) register exchanges data with external slave devices.

SPIMDATA

BIT	15	14	13	12	11	10	9	8	7	6	5	4	3	2	1	0
FIELD	DATA															
RESET	0x0000															
ADDR	0x(FF)FFFF800															

DATA

These bits are exchanged with the external device. The data must be loaded before the XCH bit in the SPIMCONT register is set. In Phase 0, data is presented on the SPMTXD pin when this register is written. In Phase 1, the first data bit is presented on the first SPMCLK edge. At the end of the exchange, data from the peripheral is present in this register and Bit 0 is the least-significant bit. As data is shifted in most-significant bit first, outgoing data is automatically MSB-justified. For example, if the exchange length is 10 bits, the first bit presented to the external device will be Bit 9, followed by the remaining bits.



Note: Writes to this field are ignored while the ENABLE bit is clear or while the XCH bit is set. This field contains unknown data if it is read while the XCH bit is set.

10.2.2 SPIM Control/Status Register

The serial peripheral interface control/status (SPIMCONT) register controls how the serial peripheral interface master operates and reports its status.

SPIMCONT

BIT	15	14	13	12	11	10	9	8	7	6	5	4	3	2	1	0
FIELD	DATA RATE			RESERVED			ENABL E	XCH	IRQ	IRQ EN	PHA	POL	BIT COUNT			
RESET	0x0000															
ADDR	0x(FF)FFFFFF802															

DATA RATE

This field selects the bit rate of the SPMCLK signal based on the division of the system clock. The master clock for the serial peripheral interface master is SYSCLK.

- 000 = Divide by 4.
- 001 = Divide by 8.
- 010 = Divide by 16.
- 011 = Divide by 32.
- 100 = Divide by 64.
- 101 = Divide by 128.
- 110 = Divide by 256.
- 111 = Divide by 512.

Bits 12–10—Reserved

These bits are reserved and read 0.

ENABLE

This bit enables the serial peripheral interface master. This bit must be asserted before you initiate an exchange and should be negated after the exchange is complete.

- 0 = The serial peripheral interface master is disabled.
- 1 = The serial peripheral interface master is enabled.

XCH—Exchange

This bit triggers a data exchange and remains set while the exchange is in progress. During the busy period, the SPIMDATA register cannot be written.

- 0 = Idle.
- 1 = Initiate an exchange (write) or busy (read).

IRQ—Interrupt Request

This bit is set when an exchange is finished. If the IRQEN bit is set, an interrupt is generated. The MSPI bit of the interrupt mask register must be cleared for the interrupt to be posted to the core. See [Section 6.6.3 Interrupt Mask Register](#) for more information. This bit remains

asserted until it is cleared by writing a zero. You can write a one to this bit to generate an interrupt request for system debugging.

0 = An exchange is in progress or idle.

1 = The exchange is complete.

IRQEN—Interrupt Request Enable

This bit enables an interrupt to be generated when a serial peripheral interface master exchange is finished. This bit does not affect the operation of the IRQ bit, it only affects the interrupt signal to the interrupt controller.

0 = Disable interrupt generation.

1 = Allow interrupt generation.

PHA—Phase

This bit controls the clock/data phase relationship.

0 = Phase 0 operation.

1 = Phase 1 operation.

POL—Polarity

This bit controls the polarity of the SPMCLK signal.

0 = Active high polarity (0 = idle).

1 = Active low polarity (1 = idle).

BIT COUNT

This field selects the length of the transfer. A maximum of 16 bits can be transferred

0000 = 1-bit transfer.

0001 = 2-bit transfer.

•

•

•

1110 = 15-bit transfer.

1111 = 16-bit transfer.

10.3 PROGRAMMING EXAMPLE

The following software code demonstrates a 10-bit exchange with the SPMCLK at 1MHz (SYSCLK = 16MHz). The interrupt bit is polled, which means no interrupt is posted to the processor.

Freescale Semiconductor, Inc.

Serial Peripheral Interface Master

```
INITIALIZE    lea #$fffff800,A0    point to SPIM registers
              lea #$fffff420,A1    point to enable bit register (Port E-3)
              andi.b #$f8,3(A1)    select Port E pins to SPIM function
              move.w #$4009,2(A0)  PHA=0, POL=0, 10-bit, divide by 16 clk

EXCHANGE     bset.b #1,2(A0)      enable SPIM module
              move.w DATA,(A0)   load data to be transmitted
              bset.b #0,2(A0)     trigger the exchange

POLL         btst.b #7,3(A0)     poll the IRQ bit
              bpl.s POLL          not set read it again

              bclr #7,3(A0)       clear the interrupt bit
              bclr #1,2(A0)       disable the SPIM
              move.b 1(A0),D0     read the data from the external device
              rts
```

SECTION 11

UNIVERSAL ASYNCHRONOUS RECEIVER/ TRANSMITTER

The universal asynchronous receiver/transmitter (UART) allows you to incorporate serial communication in your design. This section will discuss how data is transported in character blocks at a 300–1Mbps data rate using the standard “start-stop” format. It will also discuss how to configure and program the UART module, which has the following features:

- Full-duplex operation
- Flexible 5-wire serial interface
- Direct “glueless” support of IrDA physical layer protocol
- Robust receiver data sampling with noise filtering
- 12-byte FIFO for receive, 8-byte FIFO for transmit
- “Old data” timer on receive FIFO
- 7- and 8-bit operation with optional parity
- Break generation and detection
- Baud rate generator
- Flexible clocking options
- Standard baud rates 300bps to 115.2kbps with 16x sample clock
- External 1x clock for high-speed synchronous communication
- Eight maskable interrupts
- Low-power idle mode

The UART module performs all of the normal operations associated with start-stop asynchronous communication. Serial data is transmitted and received at standard bit rates using the internal baud rate generator. For those applications that need other bit rates, a 1x clock mode is available that allows you to provide a data-bit clock. Figure 11-1 illustrates a high-level block diagram of the UART module.

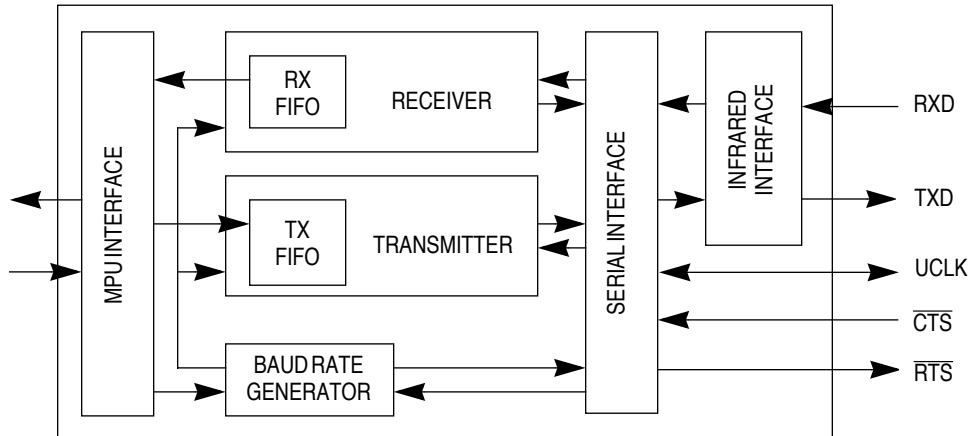

Figure 11-1. UART Block Diagram

11.1 SERIAL OPERATION

The UART module has two modes of operation—NRZ and IrDA.

11.1.1 NRZ Mode

The Non-Return to Zero (NRZ) mode is usually associated with RS-232. Each character is transmitted as a frame delimited by a start bit at the beginning and a stop bit at the end. Data bits are transmitted least-significant bit first and each bit is presented for a full bit time. If parity is used, the parity bit is transmitted after the most-significant bit. Figure 11-2 illustrates a character in NRZ mode.

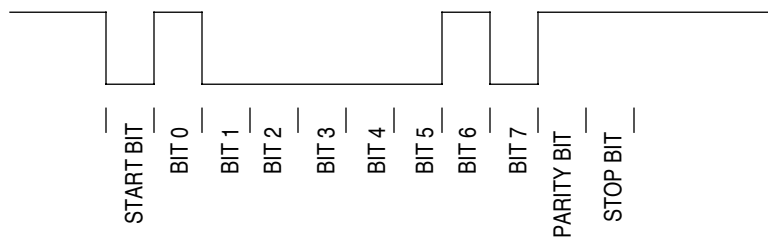

Figure 11-2. NRZ ASCII "A" Character with Odd Parity

11.1.2 IrDA Mode

Infra-red (IrDA) mode uses character frames like NRZ mode, but, instead of driving ones and zeros for a full bit time, zeros are transmitted as $\frac{3}{16}$ bit-time pulses and ones remain low. The polarity of transmitted pulses and expected receive pulses can be inverted so that

a direct connection can be made to external IrDA transceiver modules that uses active low pulses. Figure 11-3 illustrates a character in IrDA mode.

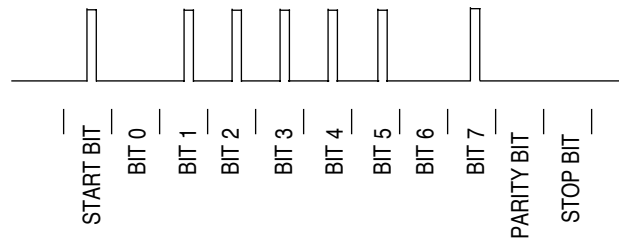

Figure 11-3. IrDA ASCII “A” Character with Odd Parity

11.1.3 SERIAL INTERFACE SIGNALS

The UART module has five signals that can be used to communicate with external UART-compatible devices.

- **TXD**—The RS-232 Transmit Data signal, which is multiplexed with PE5, is the RS-232 transmitter serial output. While the UART is in NRZ mode, normal data is output with “marks” transmitted as logic high and “spaces” transmitted as logic low. In IrDA mode, this pin, which is a 1.6µsec pulse, is output for each “zero” bit that is transmitted. The current value of this pin can be read in the TXPOL bit of the UART miscellaneous (UMISC) register. This pin connects to standard RS-232 or infra-red transceiver modules.
- **CTS** —The Clear To Send signal, which is multiplexed with PE7, is an active-low input used for transmitter flow control. The transmitter waits until this signal is asserted (low) before it starts transmitting a character. If this signal is negated while a character is being transmitted, the character will be completed, but no other character will be transmitted until this signal is asserted again. The current value of this pin can be read in the CTSSTAT bit of the UART transmitter (UTX) register.

If the NOCTS bit of the UTX register is set, the transmitter sends a character whenever a character is ready to be transmitted. You can program this pin to post an interrupt on rising and falling edges if the CTSD bit is set in the UART control (USTCNT) register. Standard RS-232 transceivers translate from RS-232 logic levels to levels that are compatible with the MC68EZ328.

- **RXD**—The Receive Data signal, which is multiplexed with PE4, is the receiver serial input. Like the TXD pin, while in NRZ mode, standard NRZ data is expected. In IrDA mode, a pulse of at least 1.0µsec is expected for each “zero” bit received. The required pulse polarity is controlled by the RXPOL bit of the UART miscellaneous (UMISC) register. This pin interfaces to standard RS-232 and infra-red transceiver modules.
- **RTS**—The Request To Send signal, which is multiplexed with PE6, serves two purposes. Normally, this signal is used for flow control, in which the receiver indicates that it is ready to receive data by asserting this pin (low). This pin is then connected to the far-end transmitter’s CTS pin. When the receiver FIFO is nearly full (four slots are remaining), which indicates a pending FIFO overrun, this pin is negated (high). When

you are not using it for flow control, this pin can be used as a general-purpose output controlled by the RTS bit of the UMISC register.

- **UCLK**—The UART Clock input/output pin serves two purposes. It can serve as the source of the clock to the baud rate generator or it can output the bit clock at the selected baud rate for synchronous operation.

11.2 SUB-BLOCK OPERATION

The UART module consists of three sub-blocks:

- Transmitter
- Receiver
- Baud rate generator

11.2.1 Transmitter

The transmitter accepts a character (byte) from the MPU bus and transmits it serially. While the FIFO is empty, the transmitter outputs continuous idle (one in NRZ mode and selectable polarity in IrDA mode). When a character is available for transmission, the start, stop, and parity (if enabled) bits are added to the character and it is serially shifted (LSB first) at the selected bit rate. The transmitter presents a new bit on each falling edge of the bit clock.

The transmitter posts a maskable interrupt when it needs parallel data (TX AVAIL). There are three maskable interrupts. If you want to take full advantage of the 8-byte FIFO, you should enable the FIFO EMPTY interrupt. The interrupt service routine should load data until the TX AVAIL bit in the UTX register is clear or until there is no more data to transmit. The transmitter will not generate another interrupt until the FIFO has completely emptied. If the driver software has a large interrupt service latency time, use the FIFO HALF interrupt. In this case, the transmitter generates an interrupt when the FIFO has fewer than 4 bytes remaining. If you do not need the FIFO, use the TX AVAIL interrupt. This interrupt is generated when at least one space is available in the FIFO. Any data that is written to the FIFO while the TX AVAIL bit is clear is ignored.

$\overline{\text{CTS}}$ is used for hardware flow control. If $\overline{\text{CTS}}$ is negated (high), the transmitter finishes sending the character in progress (if any), then waits for $\overline{\text{CTS}}$ to become asserted (low) again before starting the next character. The current state of the $\overline{\text{CTS}}$ pin is sampled by the bit clock and can be monitored by reading the CTS STAT bit of the UTX register. An interrupt can be generated when the $\overline{\text{CTS}}$ pin changes state. The CTS DELTA bit of the UTX register goes high when the $\overline{\text{CTS}}$ pin toggles. For applications that do not need hardware flow control, such as IrDA, the NOCTS bit of the UTX register should be set. While this bit is set, characters will be sent as soon as they are available in the FIFO. You can generate parity errors for debugging purposes by setting the FORCEPERR bit in the UMISC register.

The SENDBREAK bit of the UTX register is used to generate a Break character (continuous zeros). Use the following procedure to send the minimum number of valid Break characters.

1. Make sure the BUSY bit in the UTX register is set.
2. Wait until the BUSY bit goes low.

3. Clear the TXEN bit in the USTCNT register, which flushes the FIFO.
4. Wait until the BUSY bit goes low.
5. Set the TXEN bit.
6. Set the SENDBREAK bit in the UTX register.
7. Load a dummy character into the FIFO.
8. Wait until the BUSY bit goes low.
9. Clear the SENDBREAK bit.

After you finish the procedure, the FIFO should be empty and the transmitter should be idle and waiting for the next character.

If the TXEN bit of the USTCNT register is negated while a character is being transmitted, the character will be completed before the transmitter returns to IDLE. The transmit FIFO is immediately flushed when the TXEN bit is cleared. When the message has been completely sent and the UART is to be disabled, monitor the BUSY bit to determine when the transmitter has actually completed sending the final character. Remember that there may be a long time delay, depending on the baud rate. It is safe to clear the UEN bit of the USTCNT register after the BUSY bit becomes clear. The BUSY bit can also be used to determine when to disable the transmitter and turn the link around to receive IrDA applications.

When IrDA mode is enabled, the transmitter produces a pulse that is 1.6 μ sec for each “zero” bit sent. “Ones” are sent as “no pulse”. When the TXPOL bit of the UMISC register is low, pulses are active high. When the TXPOL bit is high, pulses are active low and idle is high.

11.2.2 Receiver

The receiver accepts a serial data stream and converts it into a parallel character. It operates in two modes—asynchronous and synchronous. In asynchronous mode, it searches for a start bit, qualifies it, and then samples the succeeding data bits at the perceived bit center. Jitter tolerance and noise immunity are provided by sampling 16 times per bit and using a voting circuit to enhance sampling. IrDA operation must use asynchronous mode. In synchronous mode, RXD is sampled on each rising edge of the bit clock, which is generated by the UART module or supplied externally. When a start bit is identified, the remaining bits are shifted in and loaded into the FIFO.

If parity is enabled, the parity bit is checked and its status is reported in the URX register. Similarly, frame errors, breaks and overruns are checked and reported. The four character status bits in the high byte (bits 11-8) of the URX register are valid only when read as a 16-bit word with the received character byte.

As with the transmitter, the receiver FIFO is flexible. If your software has a short interrupt latency time, the FIFO FULL interrupt in the URX register can be enabled. The FIFO has one remaining space available when this interrupt is generated. If the DATA READY bit in the URX register indicates that more data is remaining in the FIFO, the FIFO can then be emptied byte-by-byte. If the software has a longer latency time, the FIFO HALF interrupt of the URX register can be used. This interrupt is generated when no more than four empty bytes remain in the FIFO. If you do not need the FIFO, you should use the DATA READY

Freescale Semiconductor, Inc.

Universal Asynchronous Receiver/Transmitter

interrupt. This interrupt is generated when one or more characters are present in the FIFO. The OLD DATA bit in the URX register indicates that there is data in the FIFO and that the receive line has been idle for more than 30 bit times. This is useful in determining the end of a block of characters.

When IrDA mode is enabled, the receiver expects narrow (1.6 μ sec nominal) pulses for each “zero” bit received. Otherwise, normal NRZ is expected. An infra-red transceiver directly connected to the RXD pin transforms the infra-red signal into an electrical signal. Polarity is programmable so that you can connect directly to external IrDA transceivers.

11.2.3 Baud Rate Generator

The baud generator provides the bit clocks to the transmitter and receiver blocks. It consists of two prescalers, an integer prescaler and a second non-integer prescaler, as well as a 2^n divider. Figure 11-4 illustrates a block diagram of the baud rate generator.

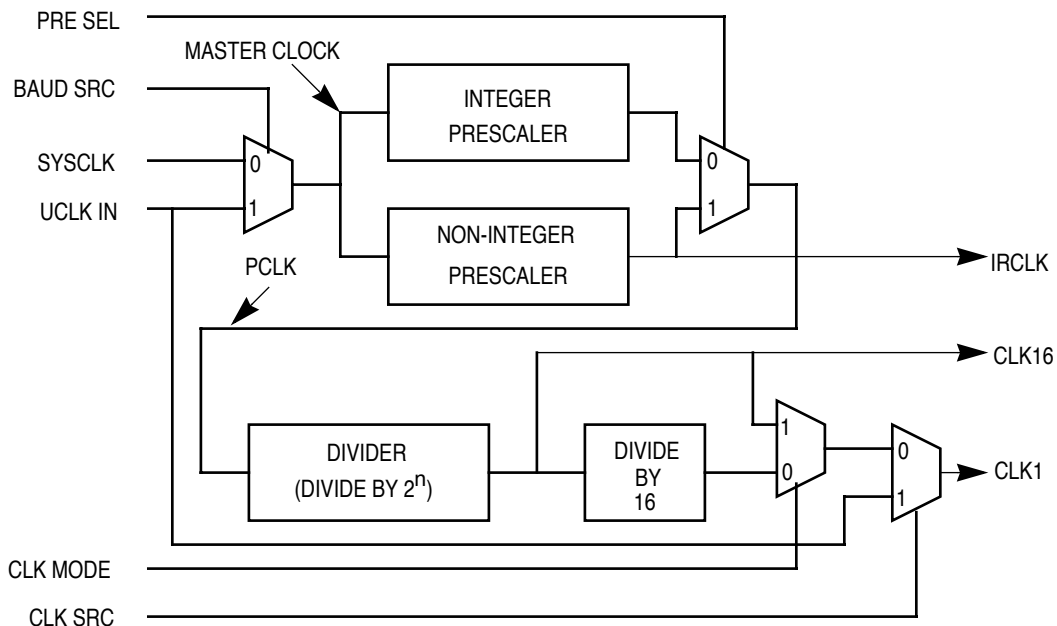

Figure 11-4. Baud Rate Generator Block Diagram

The baud rate generator’s master clock source can be the system clock (SYSCLK) or it can be provided by the UCLK pin (input mode). By setting the BAUDSRC bit of the UART baud control (UBAUD) register to 1, an external clock can directly drive the baud rate generator. For synchronous applications, you can configure the UCLK pin as an input or output for the 1x bit-clock.

11.2.3.1 DIVIDER. The divider is a 2^n binary divider with eight taps—1, 2, 4, 8, 16, 32, 64, and 128. The selected tap is the 16x clock (CLK16) for the receiver. This clock is further divided by 16 to provide a 50% duty-cycle 1x clock (CLK1) to the transmitter. While the CLKM bit of the USTCNT register is high, CLK1 is directly sourced by the CLK16 signal.

11.2.3.2 NON-INTEGGER PRESCALER. The non-integer prescaler is used for IrDA operation or to generate special nonstandard baud frequencies. For example, in IrDA mode, the non-integer prescaler provides a clock at 1.843200MHz (115.200kHz x 16). This clock is used to generate transmit pulses, which are $\frac{3}{16}$ of a 115.200kHz bit time at any selected baud rate. The non-integer prescaler can also be used to generate special baud frequencies. Table 11-1 contains the values to use for IrDA operation.

Table 11-1. Non-Integer Prescaler Values

SELECT (BINARY)	MINIMUM DIVISOR	MAXIMUM DIVISOR	STEP SIZE
000	2	3 127/128	1/128
001	4	7 63/64	1/64
010	8	15 31/32	1/32
011	16	31 15/16	1/16
100	32	63 7/8	1/8
101	64	127 3/4	1/4
110	128	255 1/2	1/2
111	—	—	—

Table 11-2 contains the values to program into the non-integer prescaler register for IrDA operation.

Table 11-2. Non-Integer Prescaler Settings

MODE	SELECT (BINARY)	X VALUE (HEX)
IrDA	010	0x20

11.2.3.3 INTEGER PRESCALER. The baud rate generator can provide standard baud rates from many system clock frequencies. However, it is optimal if the PLL is operating at the default multiplier (506, [P = 0x23, Q = 0x1]) with a 32.768kHz crystal or a multiplier of 432, (P = 0x1D, Q = 0xB) with a 38.400kHz crystal. With a 32.768kHz crystal, standard baud clocks can be generated to within 0.1% accuracy. With a 38.400kHz crystal, the baud clocks are generated with 0% error. Table 11-3 contains the values that you should use in the UBAUD register for these system frequencies.

Table 11-3. Selected Baud Rate Settings

BAUD RATE	DIVIDER	PRESCALER (HEX)
115200	0	0x38
57600	1	0x38

Table 11-3. Selected Baud Rate Settings (Continued)

BAUD RATE	DIVIDER	PRESCALER (HEX)
28800	2	0x38
14400	3	0x38
38400	0	0x26
19200	1	0x26
9600	2	0x26
4800	3	0x26
2400	4	0x26
1200	5	0x26
600	6	0x26
300	7	0x26

11.3 PROGRAMMING MODEL

11.3.1 UART Status/Control Register

The UART status/control register (USTCNT) controls the overall operation of the UART module.

USTCNT

BIT	15	14	13	12	11	10	9	8	7	6	5	4	3	2	1	0
FIELD	UEN	RXEN	TXEN	CLKM	PEN	ODD	STOP	8/7	ODEN	CTSD	RXFE	RXHE	RXRE	TXEE	TXHE	TXAE
RESET	0x0000															
ADDR	0x(FE)FFF900															

UEN—UART Enable

This bit enables the UART module. This bit resets to 0.

0 = UART module is disabled.

1 = UART module is enabled.



Note: When the UART module is first enabled after a hard reset and before you enable the interrupts, set the UEN and RXEN bits and perform a word read operation on the URX register to initialize the FIFO and character status bits.

RXEN—Receiver Enable

This bit enables the receiver block. This bit resets to 0.

- 0 = Receiver is disabled and the receive FIFO is flushed.
- 1 = Receiver is enabled.

TXEN—Transmitter Enable

This bit enables the transmitter block. This bit resets to 0.

- 0 = Transmitter is disabled and the transmit FIFO is flushed.
- 1 = Transmitter is enabled.

CLKM—Clock Mode Selection

This bit selects the receiver's operating mode. When this bit is low, the receiver is in 16x mode, in which it synchronizes to the incoming datastream and samples at the perceived center of each bit period. When this bit is high, the receiver is in 1x mode, in which it samples the datastream on each rising edge of the bit clock. In 1x mode, the bit clock is driven by CLK16. This bit resets to 0.

- 0 = 16x clock mode (asynchronous mode).
- 1 = 1x clock mode (synchronous mode).

PEN—Parity Enable

This bit controls the parity generator in the transmitter and the parity checker in the receiver.

- 0 = Parity is disabled.
- 1 = Parity is enabled.

ODD—Odd Parity

This bit controls the sense of the parity generator and checker. This bit has no function if the PEN bit is low.

- 0 = Even parity.
- 1 = Odd parity.

STOP—Stop Bit Transmission

This bit controls the number of stop bits transmitted after a character. This bit has no effect on the receiver, which expects one or more stop bits.

- 0 = One stop bit is transmitted.
- 1 = Two stop bits are transmitted.

8/7—8- or 7-Bit

This bit controls the character length. The transmitter ignores Data Bit 7 and the receiver sets it to 0.

- 0 = 7-bit transmit-and-receive character length.
- 1 = 8-bit transmit-and-receive character length.

Freescale Semiconductor, Inc.**Universal Asynchronous Receiver/Transmitter****ODEN—Old Data Enable**

This bit enables an interrupt when the OLD DATA bit in the URX register is set.

- 0 = OLD DATA interrupt is disabled.
- 1 = OLD DATA interrupt is enabled.

CTSD—CTS Delta Enable

When this bit is high, it enables an interrupt when the $\overline{\text{CTS}}$ pin changes state. When it is low, this interrupt is disabled. The current status of the $\overline{\text{CTS}}$ pin is read in the UTX register.

- 0 = $\overline{\text{CTS}}$ interrupt is disabled.
- 1 = $\overline{\text{CTS}}$ interrupt is enabled.

RXFE—Receiver Full Enable

When this bit is high, it enables an interrupt when the receiver FIFO is full. This bit resets to 0.

- 0 = RX FULL interrupt is disabled.
- 1 = RX FULL interrupt is enabled.

RXHE—Receiver Half Enable

When this bit is high, it enables an interrupt when the receiver FIFO is more than half full. This bit resets to 0.

- 0 = RX HALF interrupt is disabled.
- 1 = RX HALF interrupt is enabled.

RXRE—Receiver Ready Enable

When this bit is high, it enables an interrupt when the receiver has at least one data byte in the FIFO. When it is low, this interrupt is disabled.

- 0 = RX interrupt is disabled.
- 1 = RX interrupt is enabled.

TXEE—Transmitter Empty Enable

When this bit is high, it enables an interrupt when the transmitter FIFO is empty and needs data. When it is low, this interrupt is disabled.

- 0 = TX EMPTY interrupt is disabled.
- 1 = TX EMPTY interrupt is enabled.

TXHE—Transmitter Half Empty Enable

When this bit is high, it enables an interrupt when the transmit FIFO is less than half full. When it is low, the TX HALF interrupt is disabled. This bit resets to 0.

- 0 = TX HALF interrupt is disabled.
- 1 = TX HALF interrupt is enabled.

TXAE—Transmitter Available For New Data

When this bit is high, it enables an interrupt if the transmitter has a slot available in the FIFO. When it is low, this interrupt is disabled. This bit resets to 0.

- 0 = TX AVAIL interrupt is disabled.
- 1 = TX AVAIL interrupt is enabled.

11.3.2 UART Baud Control Register

The UART baud control (UBAUD) register controls the operation of the baud rate generator, the integer prescaler, and the UCLK pin.

UBAUD

BIT	15	14	13	12	11	10	9	8	7	6	5	4	3	2	1	0
FIELD	RESERVED		UCLK DIR	RES	BAUD SRC	DIVIDE			RESERVED		PRESCALER					
RESET	0x003F															
ADDR	0x(FF)FFF902															

Bits 15–14, 12, and 7–6—Reserved

These bits are reserved and should be set to 0.

UCLKDIR—UCLK Direction

This bit controls the direction of the UCLK pin. When this bit is low, the pin is an input and when it is high, UCLK is an output. However, the SELx bit in the Port E registers must be 0. See [Section 7.2.5 Port E Registers](#) for more information.

- 0 = UCLK is an input.
- 1 = UCLK is an output.

BAUD SRC—Baud Source

This bit controls the clock source to the baud rate generator.

- 0 = Baud rate generator source is a system clock.
- 1 = Baud rate generator source is a UCLK pin (UCLKDIR must be set to 0).

Freescale Semiconductor, Inc.**Universal Asynchronous Receiver/Transmitter****DIVIDE**

These bits control the clock frequency produced by the baud rate generator.

- 000 = Divide by 1.
- 001 = Divide by 2.
- 010 = Divide by 4.
- 011 = Divide by 8.
- 100 = Divide by 16.
- 101 = Divide by 32.
- 110 = Divide by 64.
- 111 = Divide by 128.

PRESCALER

These bits control the division value of the baud generator prescaler. The division value is determined by the following formula:

$$\text{Prescaler division value} = 65 \text{ (decimal)} - \text{PRESCALER}$$

11.3.3 UART Receiver Register

The UART receiver (URX) register indicates the status of the receiver FIFO and character data. The FIFO status bits reflect the current status of the FIFO. At initial power-up, these bits contain random data. Before you enable the receiver interrupts, you should set the UEN and RXEN bits in the USTCNT register. Reading the UART receiver register initializes the FIFO status bits. The receiver interrupts can then be enabled. However, the character status bits are only valid when read with the character bits in a 16-bit read access.

URX

BIT	15	14	13	12	11	10	9	8	7	6	5	4	3	2	1	0
FIELD	FIFO FULL	FIFO HALF	DATA READY	OLD DATA	OVRUN	FRAME ERROR	BREAK	PARITY ERROR	RX DATA							
RESET	0X0000															
ADDR	0x(FF)FFF904															

FIFO FULL (FIFO Status)

This read-only bit indicates that the receiver FIFO is full and may generate an overrun. This bit generates a maskable interrupt.

- 0 = Receiver FIFO is not full.
- 1 = Receiver FIFO is full.

FIFO HALF (FIFO Status)

This read-only bit indicates that the receiver FIFO has four or fewer slots remaining in the FIFO. This bit generates a maskable interrupt.

0 = Receiver FIFO has no more than four slots available.

1 = Receiver FIFO has more than four slots available.

DATA READY (FIFO Status)

This read-only bit indicates that at least one byte is present in the receive FIFO. The character bits are valid only while this bit is set. This bit generates a maskable interrupt.

0 = No data in the receiver FIFO.

1 = Data in the receiver FIFO.

OLD DATA (FIFO Status)

This read-only bit indicates that data in the FIFO is older than 30 bit-times. It is useful in situations where the FIFO FULL or FIFO HALF interrupts are used. If there is data in the FIFO, but below the interrupt threshold, a maskable interrupt can be generated to alert the software that unread data is present. This bit clears when the character bits are read.

0 = FIFO is empty or the data in the FIFO is < 30 bit-times old.

1 = Data in the FIFO is > 30 bit-times old.

OVRUN—FIFO Overrun (Character Status)

This read-only bit indicates that the receiver overwrote data in the FIFO. The character with this bit set is valid, but at least one previous character was lost. In normal circumstances, this bit should never be set. It indicates that your software is not keeping up with the incoming data rate. This bit is updated and valid for each received character.

0 = No FIFO overrun occurred.

1 = A FIFO overrun was detected.

FRAME ERROR (Character Status)

This read-only bit indicates that the current character had a framing error (missing stop bit), which indicates that there may be corrupted data. This bit is updated for each character read from the FIFO.

0 = The character has no framing error.

1 = The character has a framing error.

BREAK (Character Status)

This read-only bit indicates that the current character was detected as a BREAK. The data bits are all zero and the stop bit is also zero. The FRAME ERROR bit will always be set when this bit is set and if odd parity is selected, PARITY ERROR will also be set. This bit is updated and valid with each character read from the FIFO.

0 = The character is not a break character.

1 = The character is a break character.

Freescale Semiconductor, Inc.

Universal Asynchronous Receiver/Transmitter

PARITY ERROR (Character Status)

This read-only bit indicates that the current character was detected with a parity error, which indicates that there may be corrupted data. This bit is updated and valid with each character read from the FIFO. While parity is disabled, this bit always reads zero.

RX DATA (Character Data)

This read-only field is the top receive character in the FIFO. They have no meaning if the DATA READY bit is 0. In 7-bit mode, the most-significant bit is forced to zero and in 8-bit mode, all bits are active.

11.3.4 UART Transmitter Register

The UART transmitter (UTX) register controls how the transmitter operates.

UTX

BIT	15	14	13	12	11	10	9	8	7	6	5	4	3	2	1	0
FIELD	FIFO EMPTY	FIFO HALF	TX AVAIL	SEND BREAK	NO CTS	BUSY	CTS STAT	CTS DELTA	TX DATA							
RESET	0x0000															
ADDR	0x(FE)FFF906															

FIFO EMPTY (FIFO Status)

This read-only bit indicates that the transmitter FIFO is empty. This bit generates a maskable interrupt.

- 0 = Transmitter FIFO is not empty.
- 1 = Transmitter FIFO is empty.

FIFO HALF (FIFO Status)

This read-only bit indicates that the transmitter FIFO is less than half full. This bit generates a maskable interrupt.

- 0 = Transmitter FIFO is more than half full.
- 1 = Transmitter FIFO is less than half full.

TX AVAIL—Transmit FIFO Has a Slot Available (FIFO Status)

This read-only bit indicates that the transmitter FIFO has at least one slot available for data. This bit generates a maskable interrupt.

- 0 = Transmitter does not need data.
- 1 = Transmitter needs data.

SEND BREAK (Tx Control)

This bit forces the transmitter to immediately send continuous zeros, which creates a break character. See [Section 11.2.1 Transmitter](#) for a description of how to generate a break.

- 0 = Normal transmission.
- 1 = Send break (continuous zeros).

NOCTS (Tx Control)—Ignore $\overline{\text{CTS}}$

When this bit is high, it forces the $\overline{\text{CTS}}$ signal that is presented to the transmitter to always be asserted, which effectively ignores the external pin.

- 0 = Transmit only while the $\overline{\text{CTS}}$ signal is asserted.
- 1 = Ignore the $\overline{\text{CTS}}$ signal.

BUSY (Tx Status)

When this bit is high, it indicates that the transmitter is busy sending a character. This bit is asserted while the transmitter state machine is not idle or the FIFO has data in it.

- 0 = The transmitter is not sending a character.
- 1 = The transmitter is sending a character.

CTSSTAT (CTS Bit)— $\overline{\text{CTS}}$ Status

This bit indicates the current status of the $\overline{\text{CTS}}$ signal. A “snapshot” of the pin is taken immediately before this bit is presented to the data bus. While the NOCTS bit is high, this bit can serve as a general-purpose input.

- 0 = $\overline{\text{CTS}}$ signal is low.
- 1 = $\overline{\text{CTS}}$ signal is high.

CTS DELTA (CTS Bit)

When this bit is high, it indicates that the $\overline{\text{CTS}}$ signal changed state and generates a maskable interrupt. The current state of the $\overline{\text{CTS}}$ signal is available on the CTSSTAT bit. You can generate an immediate interrupt by setting this bit high. The $\overline{\text{CTS}}$ interrupt is cleared by writing 0 to this bit.

- 0 = The $\overline{\text{CTS}}$ signal did not change state since it was last cleared.
- 1 = The $\overline{\text{CTS}}$ signal has changed state.

TX DATA (Character) (Write-Only)

This write-only field is the parallel transmit-data input. In 7-bit mode, Bit 7 is ignored and in 8-bit mode, all of the bits are used. Data is transmitted least-significant bit first. A new character is transmitted when this field is written and have passed through the FIFO.

11.3.5 UART Miscellaneous Register

The UART miscellaneous (UMISC) register contains miscellaneous bits to control test features of the UART module. Some bits, however, are only for factory testing and should not be used.

UMISC

BIT	15	14	13	12	11	10	9	8	7	6	5	4	3	2	1	0
FIELD	BAUD TEST	CLK SRC	FORCE PERR	LOOP	BAUD RESET	IR TEST	0	0	RTS CONT	RTS	IRDA EN	IRDA LOOP	RX POL	TX POL	0	0
RESET	0x0000															
ADDR	0x(FF)FFF908															

BAUD TEST—Baud Rate Generator Testing

This bit puts the baud rate generator in test mode. The integer and non-integer prescalers, as well as the divider, are broken into 4-bit nibbles for testing. This bit should remain 0 for normal operation.

- 0 = Normal mode.
- 1 = Test mode.

CLK SRC—Clock Source

This bit selects the source of the 1x bit clock for transmission and reception. When this bit is high, the bit clock is derived directly from the UCLK pin (it must be configured as an input.) When it is low (normal), the bit clock is supplied by the baud rate generator. This bit allows high-speed synchronous applications, in which a clock is provided by the external system.

- 0 = Bit clock is generated by the baud rate generator.
- 1 = Bit clock is supplied by the UCLK pin.

FORCE PERR—Force Parity Error

When this bit is high, it forces the transmitter to generate parity errors, if parity is enabled. This bit is for system debugging.

- 0 = Generate normal parity.
- 1 = Generate inverted parity (error).

LOOP—Loopback

This bit controls loopback for system testing purposes. When this bit is high, the receiver input is internally connected to the transmitter and ignores the RXD pin. The TXD pin is unaffected by this bit.

- 0 = Normal receiver operation.
- 1 = Internally connects the transmitter output to the receiver input.

BAUD RESET—Baud Rate Generator Reset

This bit resets the baud rate generator counters.

- 0 = Normal operation.
- 1 = Reset baud counters.

IR TEST—Infra-Red Testing

This bit connects the output of the IrDA circuitry to the TXD pin. This provides test visibility to the IrDA module.

- 0 = Normal operation.
- 1 = IrDA test mode.

RTS CONT— $\overline{\text{RTS}}$ Control

This bit selects the function of the $\overline{\text{RTS}}$ pin.

- 0 = $\overline{\text{RTS}}$ pin is controlled by the RTS bit.
- 1 = $\overline{\text{RTS}}$ pin is controlled by the receiver FIFO. When the FIFO is full (one slot is remaining), $\overline{\text{RTS}}$ is negated.

RTS—Request to Send Pin

This bit controls the $\overline{\text{RTS}}$ pin when the RTS CONT bit is 0.

- 0 = $\overline{\text{RTS}}$ pin is 1.
- 1 = $\overline{\text{RTS}}$ pin is 0.

IRDA EN—Infra-Red Enable

This bit enables the IrDA interface.

- 0 = Normal NRZ operation.
- 1 = IrDA operation.

IRDA LOOP—Loop Infra-Red

This bit controls the loopback from the transmitter to the receiver in the IrDA interface. This bit is used for system testing purposes.

- 0 = No infra-red loop.
- 1 = Connect the infra-red transmitter to an infra-red receiver.

RX POL—Receive Polarity

This bit controls the polarity of the received data.

- 0 = Normal polarity (1 = idle).
- 1 = Inverted polarity (0 = idle).

TX POL—Transmit Polarity

This bit controls the polarity of the transmitted data.

0 = Normal polarity (1 = idle).

1 = Inverted polarity (0 = idle).

11.3.6 UART Non-Integer Prescaler Register

The UART non-integer prescaler register (NIPR) contains the control bits for the non-integer prescaler.

NIPR

BIT	15	14	13	12	11	10	9	8	7	6	5	4	3	2	1	0
FIELD	PRE SEL	RESERVED				SELECT			STEP VALUE							
RESET	0x0000															
ADDR	0xFF90A															

PRE SEL—Prescaler Selection

This bit selects the input to the baud rate generator divider. Refer to Figure 11-4 for information about selecting the prescaler.

0 = Divider source is from the integer prescaler.

1 = Divider source is from the non-integer prescaler.

Bits 14–11—Reserved

These bits are reserved and should be set to 0.

SELECT—Tap Selection

This field selects a tap from the non-integer divider.

000 = Divide range is 2 to $3^{127}/_{128}$ in $1/_{128}$ steps.

001 = Divide range is 4 to $7^{63}/_{64}$ in $1/_{64}$ steps.

010 = Divide range is 8 to $15^{31}/_{32}$ in $1/_{32}$ steps.

011 = Divide range is 16 to $31^{15}/_{16}$ in $1/_{16}$ steps.

100 = Divide range is 32 to $63^7/_8$ in $1/8$ steps.

101 = Divide range is 64 to $127^3/_4$ in $1/4$ steps.

110 = Divide range is 128 to $255^{1/2}$ in $1/2$ steps.

111 = Disable the non-integer prescaler.

STEP VALUE

This field selects the non-integer prescaler's step value.

0000 0000. Step = 0.

0000 0001. Step = 1.

-
-
-

1111 1110. Step = 254.

1111 1111. Step = 255.

11.4 NON-INTEGGER PRESCALER PROGRAMMING EXAMPLE

The following steps show you how to generate a 3.072MHz clock frequency from a 16.580608MHz clock source.

1. Calculate the divisor:
(divisor = $16.580608\text{MHz} \div 3.072000\text{MHz} = 5.397333$).
2. Find the value for the SELECT field in the NIPR. The divisor is between 4 and 8, so Table 11-1 indicates that the SELECT field is 001. The divisor step size for the selected range is $1/64$.
3. Find the number of steps to program into the STEP VALUE field by subtracting the minimum divisor from the divisor ($5.397333 - 4 = 1.397333$) and dividing this value by the step size ($1/64$ or 0.015625) ($1.397333 \div 0.015625 = 89.42$). Then you should round it to the nearest integer value and convert this value to the hex equivalent:

89 (decimal) = 59 (hex)

The actual divisor will be 5.390625, which will produce a frequency of 3.075823MHz (0.12% above the preferred frequency).



SECTION 12

LCD CONTROLLER

The liquid crystal display (LCD) controller provides display data for external LCD drivers or for an LCD panel. The LCD controller fetches display data directly from system memory through periodic DMA transfer cycles. It uses very little bus bandwidth, which gives the core sufficient processing time. The following list contains the features of the LCD controller.

- Shares system and display memory, but no dedicated video memory is required
- Standard panel interface for common LCD drivers
- Supports single (non-split) screen monochrome/color STN LCD panels
- Fast fly-by type, 16-bit wide burst DMA screen refresh transfers from system memory
- Maximum display size is 640x512 pixels for b/w and 320x240 for gray display
- Panel interface of 4-, 2-, and 1-bit wide LCD data bus
- Four or sixteen simultaneous gray-scale levels from a palette of 16
- Hardware blinking cursor that is programmable at a maximum 31x31 pixels
- Hardware panning (soft horizontal scrolling)
- 8-bit pulse-width modulator for software contrast control

The LCD controller consists of MPU interface registers, control logic, a screen DMA controller, line buffer, cursor logic, frame rate control, and an LCD panel interface. Figure 12-1 illustrates how these blocks are organized in the LCD controller.



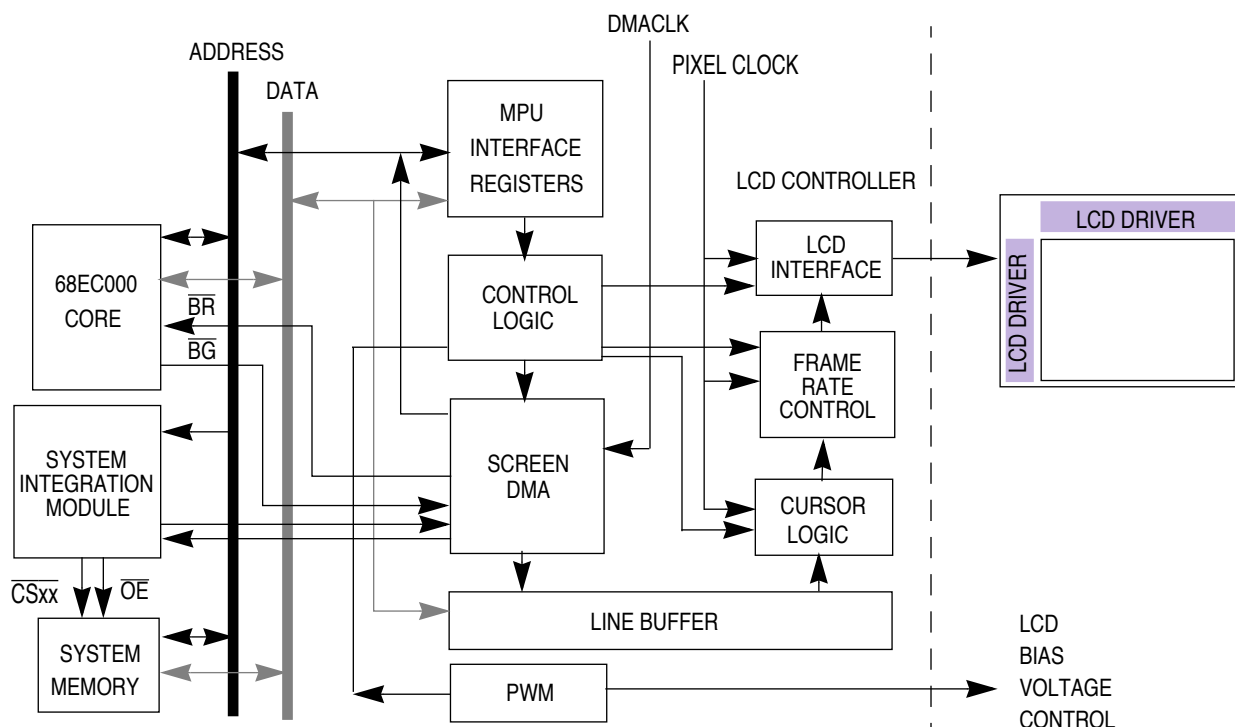

Figure 12-1. LCD Controller Block Diagram

12.1 OPERATION

The MPU interface registers enable the different features of the LCD controller. They are connected to the 68K bus. The control logic provides the internal control and counting signals for other blocks. The DMA generates a bus request (\overline{BR}) signal to the core and when the bus is granted, it performs a few memory bursts to fill up the line buffer. The number of DMA clock cycles in each burst is the programmable number of clocks per transfer, which makes it easier to support a system with memory that has different speed grades.

The line buffer collects display data from system memory during DMA cycles and outputs it to the cursor logic block. The input is synchronized with the fast DMA clock, while the output is synchronized to the relatively slow LCD pixel clock. The cursor control logic, when enabled, is used to generate a block-shaped cursor on the display screen. You can change the height and width of the cursor, as long as you use a number between 1 and 31. The cursor can be completely black or reversed video and the blinking rate is adjustable when the BKEN bit in the LCD blink control (LBLKC) register is set.

Frame rate control is mainly used for gray-scale displays and can generate a maximum of sixteen gray-scale levels out of 16 density levels, as shown in Table 12-1. The density level corresponds to the number of times that a pixel is turned on when the display is refreshing. Since crystal formulations and driving voltage may vary, the quality of the gray-scale can be fine-tuned by programming the LCD gray palette mapping register (LGPMR).

The LCD interface logic is used to pack the display data into the correct size and output it to the LCD panel's data bus. The polarity of the LFLM, LP, and LCLK signals and pixel data can all be programmed to suit different LCD panel requirements.

12.1.1 Connecting the LCD Controller to an LCD Panel

The following signals are used to connect the LCD controller to an LCD panel:

- **LD[3:0]**. The LCD Data Bus lines transfer pixel data to the LCD panel so that it can be displayed. Depending on which LCD panel mode is selected, data is arranged differently on the bus. You can program the output pixel data to be negated. See [Section 12.2.10 LCD Polarity Configuration Register](#) for more information. The LCD controller is configured to drive single-screen monochrome LCD panels only. The data bus size for an LCD panel can be configured to 1-, 2-, or 4-bit by programming the LCD panel bus size (LPBSIZ) register.
- **LFLM**. The LCD Frame Marker signal indicates the start of a new display frame. LFLM becomes active after the first line pulse of the frame and remains active until the next line pulse, at which point it deasserts and remains inactive until the next frame. You can program LFLM to be an active high or active low signal in software. See [Section 12.2.10 LCD Polarity Configuration Register](#) for more information.
- **LLP**. The LCD Line Pulse signal is used to latch a line of shifted data onto an LCD panel. It becomes active when a line of pixel data is clocked into the LCD panel and stays asserted for an 8-pixel clock period. You can program LLP to be an active high or active low signal in software. See [Section 12.2.10 LCD Polarity Configuration Register](#) for more information.
- **LCLK**. The LCD Shift Clock signal is the clock output to which the output data to the LCD panel is synchronized. You can program LCLK to be an active high or active low signal in software. See [Section 12.2.10 LCD Polarity Configuration Register](#) for more information.
- **LACD**. The LCD Alternate Crystal Direction output signal is toggled to alternate the crystal polarization on the panel. You can program this signal to toggle for a period of 1 to 16 frames. The LACD signal will toggle after a preprogrammed number of FLM or LP pulses. The LACD rate control register (LACDRC) can be programmed so that LACD will toggle once every 1 to 16 frames. The targeted number is equal to the alternation code's 4-bit value plus one. The default value for LACDRC is zero, which enables the LACD signal to toggle on every frame. The LACD signal is synchronized with the trailing (falling) edge of the LLP signal, which is enclosed by the LFLM signal. See [Section 12.2.11 LACD Rate Control Register](#) for more information.

12.1.1.1 PANEL INTERFACE TIMING. The LCD controller continuously pumps the pixel data into the LCD panel via the LCD data bus. The bus is timed by the LCLK, LLP and LFLM signals. The LCLK signal clocks the pixel data into the display drivers' internal shift register. The LLP signal latches the shifted pixel data into a wide latch at the end of a line while the LFLM signal marks the first line of the displayed page.

The LCD controller is designed to support most monochrome LCD panels. Figure 12-2 illustrates the LCD interface timing for 1-, 2-, and 4-bit LCD data bus operation. The LLP

signal signifies the end of the current line of serial data. The LLP signal enclosed by the LFLM signal marks the end of the first line of the current frame.

Some LCD panels can use an active low LFLM, LLP, or LCLK signal and reversed pixel data. To change the polarity of these signals, set the FLMPOL, LPPOL, LCKPOL and PIXPOL bits in the LCD polarity configuration (LPOLCF) register to 1. In addition to the interface timing pins, the LACD pin will toggle after a preprogrammed number of LFLM pulses. The purpose of this pin is to prevent the crystal in the LCD panel from degrading.

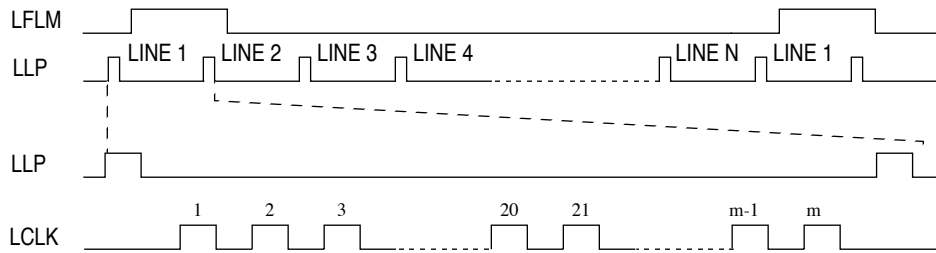

4-BIT LCD DATA BUS (PBSIZ = 10)

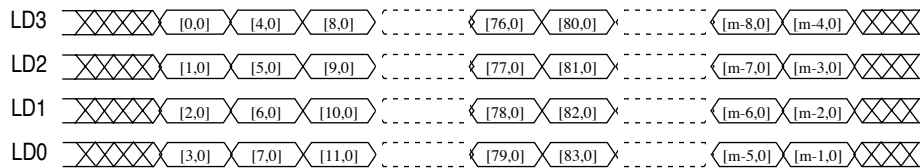

2-BIT LCD DATA BUS (PBSIZ = 01)

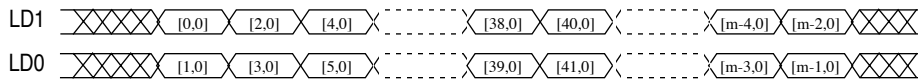

1-BIT LCD DATA BUS (PBSIZ = 00)

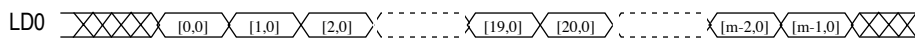

Figure 12-2. LCD Interface Timing for 4-, 2-, and 1-Bit Data Widths

12.1.2 Controlling the Display

The LCD controller is designed to drive single-screen monochrome STN LCD panels with up to 640 x 512 pixels in black-and-white display and 320 x 240 in gray level display. Screen size larger than 320 x 240 for gray level display may cause flickering due to slow refresh rate. The best efficiency is achieved when the screen width is a multiple of the DMA controller's 16-bit bus width.

12.1.2.1 FORMAT OF THE LCD SCREEN. The screen width and height of the LCD panel are software programmable. Figure 12-3 illustrates the relationship between the portion of a large graphics file displayed on the screen versus the actual page. The units in the figure are measured in pixel counts.

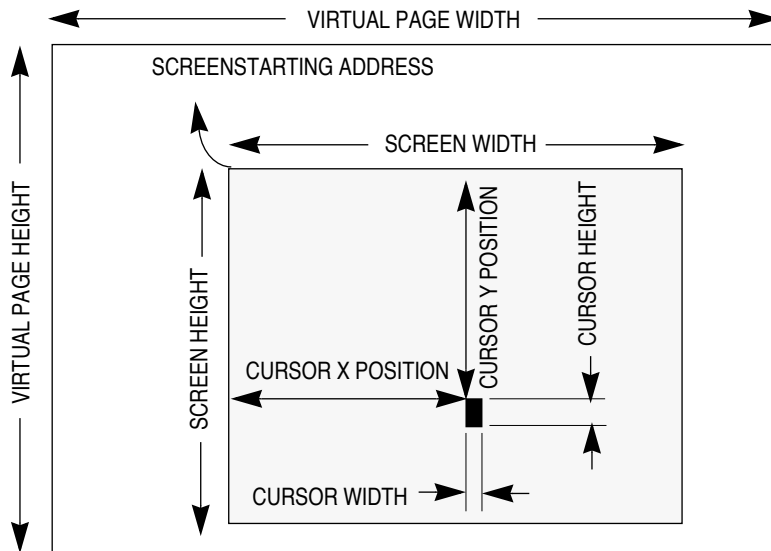

Figure 12-3. LCD Screen Format

The LCD screen width (LXMAX) and LCD screen height (LYMAX) registers are where you specify the size of the LCD panel. The LCD controller will start scanning the display memory at the location pointed to by the LCD screen starting address (LSSA) register. Therefore, the shaded area in Figure 12-3 will be displayed on the LCD panel.

The maximum page width and page height are specified by the LCD virtual page width (LVPW) and LCD virtual page height parameters. By changing the LSSA register, a screen-sized window can be vertically or horizontally scrolled (panned) anywhere inside the virtual page boundaries. However, it is up to your software to position the starting address so that the scanning logic's system memory pointer does not stretch beyond the virtual page width or height. Otherwise, strange objects will appear on the screen. The LVPH parameter shows the bottom of the page, but it is not used by the LCD controller.

12.1.2.2 FORMAT OF THE CURSOR. To define the position of the hardware cursor, the LCD controller maintains a vertical line counter (YCNT) to keep track of the current pixel's vertical position. YCNT, in conjunction with XCNT (the horizontal pixel counter), specifies the screen position of the pixel data being processed. When the pixel falls within a window specified by the cursor's reference position, cursor width, and cursor height, the original pixel bits can be shown with different properties. These properties can be transparent (cursor is disabled), full (black cursor), reversed video, full (white cursor), or blinking. You can make the hardware cursor blink by setting the BKEN bit in the LBLKC register to 1, which alternates the original signal and cursor periodically. You can control the speed at which the cursor blinks by selecting the BDx bit in the LBLKC register. The half-period may be as long as 2 seconds.

12.1.2.3 MAPPING THE DISPLAY DATA. The LCD controller supports 1 or 2 bits per pixel graphics mode. In the 1-bit mode, each bit in the display memory corresponds to a pixel in the LCD panel. The corresponding pixel on the screen is either fully on or fully off. Meanwhile, in 2-bit mode, each pixel is being represented by two bits of display memory. To map the data to the LCD panel, you have to program the appropriate bit in the corresponding address of the display memory. Figure 12-4 illustrates how the system memory data in both modes are mapped.

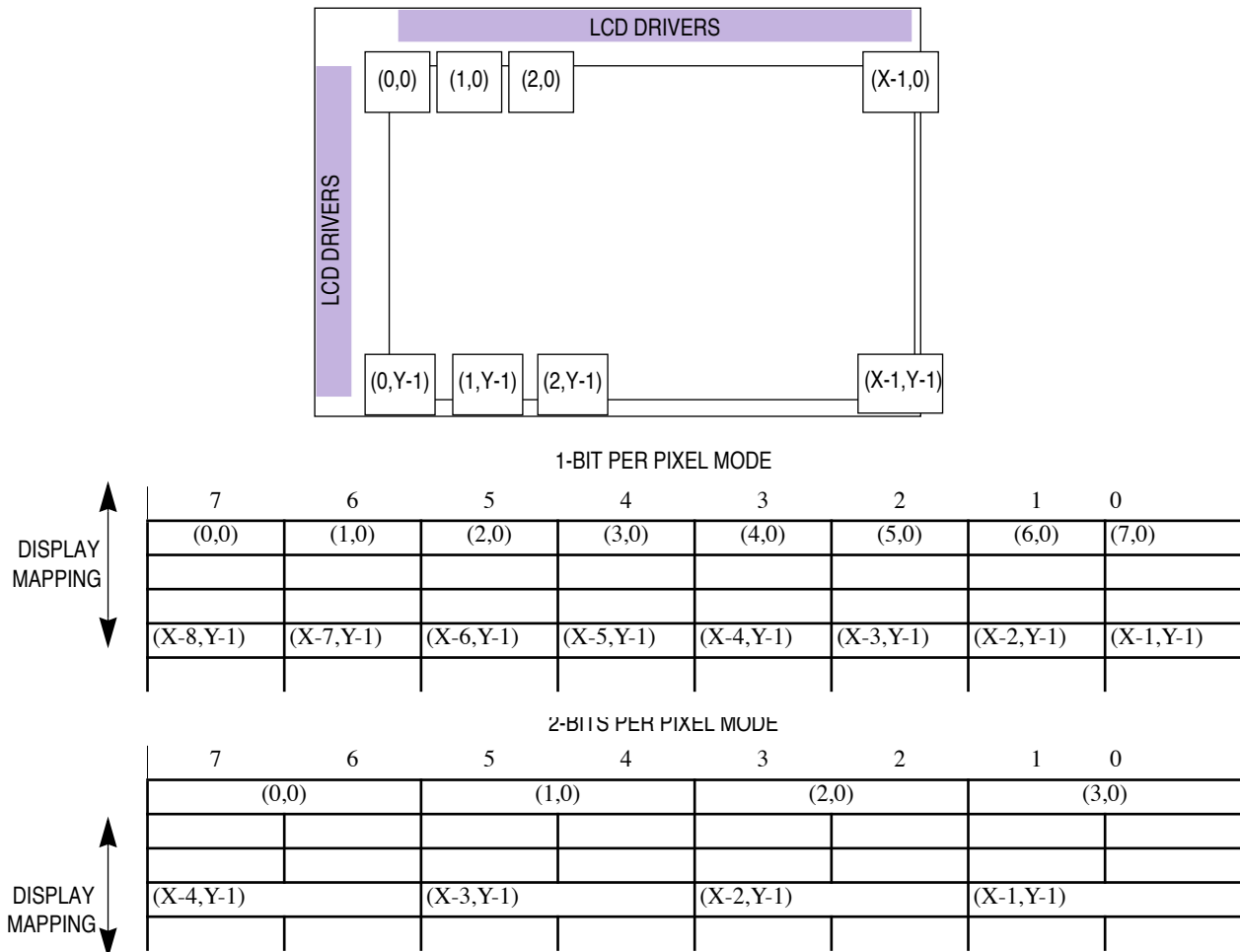

Figure 12-4. Mapping Memory Data on the Screen

12.1.2.4 GENERATING GRAY-SCALE TONES. In 2-bit per pixel mode, a proprietary frame rate control circuitry inside the LCD controller generates intermediate gray-scale tones on the LCD panel by adjusting the density of ones and zeroes that appear over the frames. The LCD controller can generate sixteen simultaneous gray-scale levels out of 16

available palettes. The two levels between black and white can be selected from Table 12-1. Use the LGPMR registers to program the gray-scale level.

Table 12-1. Gray-Scale Palette Options

GRAY-SCALE CODE	DENSITY
0000	0
0001	1/8
0010	3/16
0011	1/4
0100	5/16
0101	3/8
0110	7/16
0111	1/2
1000	9/16
1001	5/8
1010	11/16
1011	3/4
1100	13/16
1101	7/8
1110	15/16
1111	1

NOTE: 0=White and 1=Black.

Since crystal formulations and driving voltages vary, the visual gray-scale effect may or may not be linearly related to the frame rate. For certain types of graphics, a logarithmic scale like 0, $1/4$, $1/2$, and 1, might be more visually pleasing than a linearly spaced scale like 0, $5/16$, $11/16$, and 1. This flexible mapping scheme allows you to optimize the visual effect for the specific panel or application during a sixteen gray-scale level display mode.

12.1.2.5 CONTROLLING FRAME RATE MODULATION. Sometimes blinking or flickering will occur if all of the LCD pixel cells are driven at the same time. To minimize flickering, you can program two 4-bit numbers, specifically the XMOD and YMOD bits in the LCD frame rate modulation control (LFRCM) register. As a general rule, you should select odd numbers and the two values should differ by at least 2. The optimal offset values could vary among LCD panel models (even those by the same manufacturer) because of different inter-pixel cross-talk characteristics. However, the default value of the LFRCM register should work for most of the LCD panels on the market.

12.1.3 Using Low-Power Mode

Some panels may have a PANEL_OFF signal, which is used to turn off the panel for low-power mode. In an MC68EZ328 system, this signal is not supported, but can be easily implemented using a parallel I/O pin. You can program your software to achieve PANEL_OFF by using parallel I/O in the following sequence:

1. Drive the LCD bias voltage to +15V or -15V.
2. Set the LCDON bit to 0 in the LCD clocking control (LCKCON) register, which turns off the LCD controller.

To turn the LCD controller back on, follow these steps:

1. Set the LCDON bit to 1 in the LCKCON register, which turns on the LCD controller.
2. Pause for 1 or 2ms.
3. Drive the LCD bias voltage to +15V or -15V.

When you set the LCDON bit in the CLKCON register to 1, the LCD controller will enter low-power mode by stopping its own pixel clock prior to the next line buffer fill DMA. Further screen DMA and display refresh operations will then be halted in this mode. When the LCD controller is turned back on, DMA and screen refresh activities will resume synchronously.

12.1.4 Using the DMA Controller

This LCD DMA controller is a fly-by type 16-bit wide fast data transfer machine. Since the LCD screen has to be continuously refreshed at a rate of 50-70Hz, the pixel bits in the memory will be read and transferred to the corresponding pixels on the screen. To minimize bus obstruction, a burst type and fly-by transfer is required. Each cycle is evenly distributed across the time frame. Every time the internal line buffer needs data, it asserts the \overline{BR} signal to request the bus from the core. Once the core grants the bus (\overline{BG} is asserted), the DMA controller gets control of the bus signal and issues a number of words read from memory. The read data is then internally passed to the internal pixel buffer. During the LCD access cycles, output enable and chip-select signals for the corresponding system memory chip are asserted by the chip-select logic inside the system integration module. You can minimize bus bandwidth obstruction by using zero LCD access wait-states (1 clock per access).

12.1.4.1 BUS BANDWIDTH CALCULATION EXAMPLE. Since LCD screen refresh occurs periodically, the load that the LCD controller puts on the host data bus becomes an important consideration to the high performance handheld system designer. There are many issues involved in estimating bandwidth overhead to the data bus.

Consider a typical scenario:

- Screen size: 320 x 240 pixels
- Bits per pixel: 2-bits per pixel
- Screen refresh rate: 60Hz
- System clock: 16.58MHz

Host bus size: 16-bit

DMA access cycle: 2 cycles per 16-bit word

The following T_1 period is used by the LCD controller to update one line of the screen:

$$T_1 = \frac{1}{60\text{Hz}} \times \frac{1}{240 \text{ lines}}$$

$$= 69.4\mu\text{s}$$

During the same period, the line buffer must be filled. The following T_{DMA} duration is how long the DMA cycle will hold up the bus:

$$T_{\text{DMA}} = \frac{320 \text{ pixels} \times 2 \text{ bits per pixel} \times 2 \text{ clocks}}{16.67\text{MHz} \times 16\text{-bit bus}}$$

$$= 4.8\mu\text{s}$$

Thus, the percentage of host bus time taken up by LCD controller's DMA is P_{DMA} as follows:

$$P_{\text{DMA}} = \frac{4.8\mu\text{s}}{69.4\mu\text{s}}$$

$$= 6.92\%$$

12.2 PROGRAMMING MODEL

12.2.1 LCD Screen Starting Address Register

The LCD screen starting address (LSSA) register is used to inform the LCD panel where to fetch the data to be displayed.

LSSA

BIT	31	30	29	28	27	26	25	24	23	22	21	20	19	18	17	16
FIELD	RESERVED			SSA2 8	SSA2 7	SSA2 6	SSA2 5	SSA2 4	SSA2 3	SSA2 2	SSA2 1	SSA2 0	SSA1 9	SSA1 8	SSA1 7	SSA1 6
RESET	0x00000000															
ADDR	0x(F)FFFA00															
BIT	15	14	13	12	11	10	9	8	7	6	5	4	3	2	1	0
FIELD	SSA1 5	SSA1 4	SSA1 3	SSA1 2	SSA1 1	SSA1 0	SSA9	SSA8	SSA7	SSA6	SSA5	SSA4	SSA3	SSA2	SSA1	—
RESET	0x00000000															
ADDR	0x(F)FFFA00															

Bit 31–29—Reserved

These bits are reserved and must be set to 0.

SSAx—Screen Starting Address 28–1

This field is the 28-bit screen starting address of the LCD panel. The LCD controller will start fetching pixel data from system memory at this address. This field must start at a location that will enable a complete picture to be stored in a 128K memory boundary (A[16:00]). In other words, A[28:17] has a fixed value for a picture's image.

12.2.2 LCD Virtual Page Width Register

The LCD virtual page width (LVPW) register contains the width of the displayed image.

LVPW

BIT	7	6	5	4	3	2	1	0
FIELD	VP8	VP7	VP6	VP5	VP4	VP3	VP2	VP1
RESET	0xFF							
ADDR	0xFFFFFA05							

VPx—Virtual Page Width 8–1

This bit specifies the virtual page width of the LCD panel in terms of word count. The virtual page width is the virtual width in pixels divided by 16 for a black and white display and 8 for a four level gray-scale display and divided by 4 for a sixteen-level grayscale display.

12.2.3 LCD Screen Width Register

The LCD screen width register (LXMAX) is used to define the width of your LCD panel's screen. This register must be a multiple of 16.

LXMAX

BIT	15	14	13	12	11	10	9	8	7	6	5	4	3	2	1	0
FIELD	—						XM9	XM8	XM7	XM6	XM5	XM4	—			
RESET	0x03F0															
ADDR	0xFFFFFA08															

XMx—Width Maximum 9–4

These bits represent the width of the LCD panel in number of pixels.

12.2.4 LCD Screen Height Register

The LCD screen height register (LYMAX) is used to define the height of your LCD panel's screen.

LYMAX

BIT	15	14	13	12	11	10	9	8	7	6	5	4	3	2	1	0	
FIELD	-							YM8	YM7	YM6	YM5	YM4	YM3	YM2	YM1	YM0	
RESET	0x01FF																
ADDR	0x(FE)FFFA0A																

Ym_x—Height Maximum 8–0

These bits represent the height of the LCD panel in number of pixels, which is equal to YMAX+1.

12.2.5 LCD Cursor X Position Register

The LCD cursor X position (LCXP) register is used to determine the horizontal position of your cursor on the LCD panel.

LCXP

BIT	15	14	13	12	11	10	9	8	7	6	5	4	3	2	1	0	
FIELD	CC1	CC0	-				CXP9	CXP8	CXP7	CXP6	CXP5	CXP4	CXP3	CXP2	CXP1	CXP0	
RESET	0x0000																
ADDR	0x(FE)FFFA18																

CC_x—Cursor Control 1 and 0

These bits are used to control the format of your cursor.

- 00 = Transparent, cursor is disabled.
- 01 = Full (black) cursor.
- 10 = Reversed video.
- 11 = Full (white) cursor.

CXP_x—Cursor X Position 9–0

These bits represent the cursor's horizontal starting position X in pixel count (from 0 to XMAX).

12.2.6 LCD Cursor Y Position Register

The LCD cursor Y position (LCYP) register is used to determine the vertical position of your cursor on the LCD panel.

LCYP

BIT	15	14	13	12	11	10	9	8	7	6	5	4	3	2	1	0	
FIELD	-							CYP8	CYP7	CYP6	CYP5	CYP4	CYP3	CYP2	CYP1	CYP0	
RESET	0x0000																
ADDR	0x(FE)FFFA1A																

CYPx—Cursor Vertical Y Pixel 8–0

These bits represent the cursor’s vertical starting position Y in pixel count (from 0 to YMAX).

12.2.7 LCD Cursor Width and Height Register

The LCD cursor width and height (LCWCH) register is used to determine the width and height of your cursor.

LCWCH

BIT	15	14	13	12	11	10	9	8	7	6	5	4	3	2	1	0
FIELD	-			CW4	CW3	CW2	CW1	CW0	-			CH4	CH3	CH2	CH1	CH0
RESET	0x0101															
ADDR	0x(FE)FFFA1C															

CWx—Cursor Width 4–0

These bits specify the width of the hardware cursor in pixel count (from 1 to 31).

CHx—Cursor Height 4–0

These bits specify the height of the hardware cursor in pixel count (from 1 to 31).



Note: The cursor is disabled if the CWx or CHx bits are set to zero.

12.2.8 LCD Blink Control Register

The LCD blink control register (LBLKC) is used to control how your cursor blinks.

LBLKC

BIT	7	6	5	4	3	2	1	0
FIELD	BKEN	BD6	BD5	BD4	BD3	BD2	BD1	BD0
RESET	0x7F							
ADDR	0x(FF)FFFA1F							

BKEN—Blink Enable

This bit determines if the blink enable cursor will blink or remain steady.

- 1 = Blink is enabled.
- 0 = Blink is disabled (default).

BDx—Blink Divisor 6–0

These bits determine if the cursor will toggle once per a specified number of internal frame pulses plus one. The half-period may be as long as 2 seconds.

12.2.9 LCD Panel Interface Configuration Register

The LCD panel interface configuration (LPICF) register is used to determine the data bus width of the LCD panel and to determine if it is a black and white or grayscale display.

LPICF

BIT	7	6	5	4	3	2	1	0
FIELD	—				PBSIZ1	PBSIZ0	GS1	GS0
RESET	0x00							
ADDR	0x(FF)FFFA20							

PBSIZx—Panel Bus Width 1–0

- 00 = 1-bit.
- 01 = 2-bit.
- 10 = 4-bit.
- 11 = Unused.

GSx—Gray-Scale Mode Selection 1–0

- 00 = Black and white mode.
- 01 = Four level gray-scale mode.
- 10 = Sixteen level gray-scale mode.
- 11 = Reserved.

12.2.10 LCD Polarity Configuration Register

The LCD polarity configuration (LPOLCF) register controls the polarity of the interface signal that goes to the LCD panel.

LPOLCF

BIT	7	6	5	4	3	2	1	0
FIELD	—				LCKPOL	FLMPOL	LPPOL	PIXPOL
RESET	0x00							
ADDR	0x(FF)FFFA21							

LCKPOL—LCD Shift Clock Polarity

This bit controls the polarity of the active edge of the LCD shift clock.

- 0 = Active negative edge of LCLK.
- 1 = Active positive edge of LCLK.

FLMPOL—Frame Marker Polarity

This bit controls the polarity of the frame marker.

- 0 = Frame marker is active high.
- 1 = Frame marker is active low.

LPPOL—Line Pulse Polarity

This bit controls the polarity of the line pulse.

- 0 = Line pulse is active high.
- 1 = Line pulse is active low.

PIXPOL—Pixel Polarity

This bit controls the polarity of the pixels.

- 0 = Pixel polarity is active high.
- 1 = Pixel polarity is active low.

12.2.11 LACD Rate Control Register

The LCD alternate crystal direction rate control (LACDRC) register is used to control the alternate rates of the liquid crystal direction.

LACDRC

BIT	7	6	5	4	3	2	1	0
FIELD	ACDSL	—			ACD3	ACD2	ACD1	ACD0
RESET	0x00							

LACDRC

BIT	7	6	5	4	3	2	1	0
ADDR	0x(FF)FFFA23							

ACDSLTT –Signal Source Select

0 = Select Frame Pulse

1 = Select Line Pulse

ACDx—Alternate Crystal Direction Control 3–0

These bits represent the ACD toggle rate control code. The LACD signal will toggle once every 1 to 16 FLM cycles based on the value specified in this register. The actual number of FLM cycles is the value programmed plus one. Shorter cycles tend to give better results.

12.2.12 LCD Pixel Clock Divider Register

The LCD pixel clock divider (LPXCD) register is used to program the divider, which generates the pixel clock.

LPXCD

BIT	7	6	5	4	3	2	1	0
FIELD	–		PCD5	PCD4	PCD3	PCD2	PCD1	PCD0
RESET	0x00							
ADDR	0x(FF)FFFA25							

PCDx—Pixel Clock Divider 5–0

These bits represent the pixel clock divisor. The LCLK signal from the PLL is divided by N (PCD5-0 plus one) to yield the actual pixel clock. Values of 1-63 will yield N=2 to 64. If set to 0 (N=1), the PIX clock will be used directly, thus bypassing the divider circuit. Refer to for more information.

12.2.13 LCD Clocking Control Register

The LCD clocking control (LCKCON) register is used to enable the LCD controller and control the LCD memory cycle.

LCKCON

BIT	7	6	5	4	3	2	1	0
FIELD	LCDON	DWIDTH	–		DWS3	DWS2	DWS1	DWS0
RESET	0x00							
ADDR	0x(FF)FFFA27							

LCD Controller

LCDON—LCD Control

- 0 = Disable the LCD controller.
- 1 = Enable the LCD controller.

DWIDTH—Display Memory Width

This bit sets the bus width of the display memory.

- 0 = 16-bit bus width.
- 1 = 8-bit bus width.

DWSx—Display Wait-State 3–0

These bits represent the static display memory wait-state control. It is the number of clock cycles per DMA access (for SRAM or ROM only).

- 0000 = One clock cycle transfer.
- 0001 = Two clock cycle transfers.
-
-
-
- 1111 = Sixteen clock cycle transfers.

12.2.14 LCD Refresh Rate Adjustment Register

The LCD refresh rate adjustment (LRRR) register is used to fine-tune the display refresh rate by introducing an idle interval between alternate LCD DMA and display cycles.

LRRR

BIT	7	6	5	4	3	2	1	0
FIELD	RRA7	RRA6	RRA5	RRA4	RRA3	RRA2	RRA1	RRA0
RESET	0xFF							
ADDR	0x(FF)FFFA29							

RRAx—Refresh Rate 7–0

These bits contain the frame period, which can be calculated as follows:

Frame period = (6+RRA+width) x height x (PCXD+1) x LCLK,
 where:

- Frame period = Number of nanoseconds for each screen update.
- RRAx = Hexadecimal value stored in the LRRR register.
- Width = Screen width in number of pixels.
- Height = Screen height in number of pixels.
- PCXD = Hexadecimal value stored in the LPXCD register.
- LCLK = Period in nanoseconds for LCLK.

12.2.15 LCD Panning Offset Register

The LCD panning offset register (LPOSR) is used to control how many pixels the picture is shifted to the left.

LPOSR

BIT	7	6	5	4	3	2	1	0
FIELD	—				POS3	POS2	POS1	POS0
RESET	0x00							
ADDR	0x(FF)FFFA2D							

POSx—Pixel Offset Code

These bits specify the number of pixels being shifted to the left of the display panel.

POS [3:0] - Pixel Offset Code for black-and-white display

POS [2:0] - Pixel Offset Code for four level gray-scale display

POS [1:0] - Pixel Offset Code for sixteen level gray-scale display.



Note: When you modify this register, your software must adjust the cursor's reference position.

12.2.16 LCD Frame Rate Control Modulation Register

The LCD frame rate control modulation register (LFRCM) is used to minimize the flickering on your LCD panel.

LFRCM

BIT	7	6	5	4	3	2	1	0
FIELD	XMOD3	XMOD2	XMOD1	XMOD0	YMOD3	YMOD2	YMOD1	YMOD0
RESET	0xB9							
ADDR	0x(FF)FFFA31							

XMODx—Horizontal Modulation 3–0

These bits modulate adjacent pixels at different time periods to avoid spatial flicker or jitter when frame rate control is used. These values must be optimized by manually fine-tuning the target LCD panel. See [Section 12.1.2 Controlling the Display](#) for more information.

YMODx—Vertical Modulation 3–0

These bits modulate adjacent pixels at different time periods to avoid spatial flicker or jitter when frame rate control is used. These values must be optimized by manually fine-tuning the target LCD panel. See [Section 12.1.2 Controlling the Display](#) for more information.

12.2.17 LCD Gray Palette Mapping Register

For 4-level gray-scale displays, full black and full white are the two predefined display levels. The other two intermediate gray-scale shading densities can be adjusted here in the LCD gray palette mapping register (LGPMR).

LGPMR

BIT	7	6	5	4	3	2	1	0
FIELD	G23	G22	G21	G20	G13	G12	G11	G10
RESET	0x84							
ADDR	0x(FF)FFFA33							

G23–G20—Gray-Scale 23–20

These bits represent one of the two gray-scale shading densities.

G13–G10—Gray-Scale 13–10

These bits represent the other gray-scale shading density.

12.2.18 PWM Contrast Control Register

The pulse-width modulator contrast control register (PWMR) is used to control PWMO signal, which controls the contrast of the LCD panel.

PWMR

BIT	15	14	13	12	11	10	9	8	7	6	5	4	3	2	1	0	
FIELD	–				SCR1	SCR0	CCPE N	PW7	PW6	PW5	PW4	PW3	PW2	PW1	PW0		
RESET	0x0000																
ADDR	0x(FF)FFFA36																

SRCx—Source 1–0

These bits select the input clock source for the PWM counter. Therefore, the PWM output frequency is equal to the frequency of the input clock divided by 256.

- 00 = Line pulse.
- 01 = Pixel clock.
- 10 = LCD clock.
- 11 = Reserved.

CCPEN—Contrast Control Enable

The bit is used to enable or disable the contrast control function.

0 = Contrast control is off.

1 = Contrast control is on.

PWx—Pulse-Width 7–0

This bit controls the pulse-width of the built-in pulse-width modulator, which controls the contrast of your LCD screen. See for more information.

12.3 PROGRAMMING EXAMPLE

The following is an example of how to program the related registers so that you can properly configure an LCD panel with a resolution of 240x160 pixels, four levels of gray-scale, and a 4-bit LCD data interface. The virtual image is 320 pixels wide and panned by three pixels.

```
LCDINT  move.l  #$A80000, #$FFFA00 ;display data address starts at $A80000
        move.w  #240, #$FFFA08   ;LCD horizontal size is 240
        move.w  #159, #$FFFA0A   ;LCD vertical size is 160
        move.b  #40,  #$FFFA05   ;4 level grey and 320 pixels wide image
        move.b  #$09, #$FFFA20   ;LCD panel data bus is 4 bits, 4 level grey
        move.b  #3,   #$FFFA25   ;pixel clock rate equal 1/4 of LCDCLK from PLL
        move.b  #10,  #$FFFA29   ;refresh rate adjustment
        move.b  #$03, #$FFFA2D   ;shift picture by 3 pixels
        move.b  #$82, #$FFFA27   ;switch on LCDC, 2 wait state for memory cycle
```



SECTION 13

REAL-TIME CLOCK

The real-time clock module provides a current time stamp of seconds, minutes, and hours. It operates on the low-frequency 32.768kHz or 38.4kHz reference clock crystal. This section will discuss how to operate and program the real-time clock, which has the following features.

- Full clock features—seconds, minutes, hours, days
- Minute countdown timer with interrupt
- Programmable daily alarm with interrupt
- Sampling timer with interrupt
- Once-per-second and once-per-day interrupts
- 32.768kHz or 38.4kHz operation
- Two-second watchdog timer to prevent software hang-ups with programmable software resets or interrupts with system applications

The real-time clock module's block diagram is illustrated in Figure 13-1.

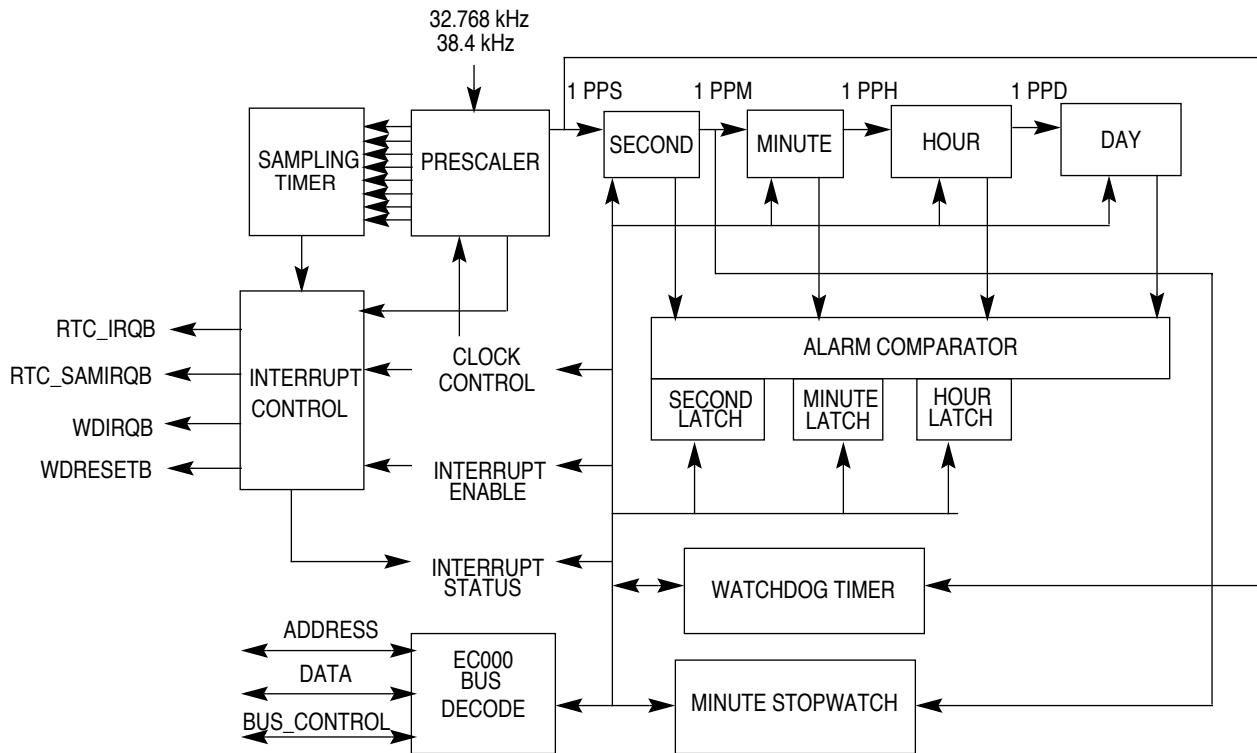

Figure 13-1. Real-Time Clock Block Diagram

13.1 OPERATION

The real-time clock module consists of the following blocks:

- Prescaler and counter
- Alarm
- Watchdog timer
- Sampling timer
- Minute stopwatch

13.1.1 Prescaler and Counter

The prescaler divides the 32.768kHz reference clock down to 1 pulse per second. An alternate reference frequency of 38.4kHz is also supported. The counter portion of this device consists of four groups of counters that are toggled by a 1Hz clock. The seconds and minutes counters are 6 bits long, the hours counter is 5 bits long, and the day counter is 9 bits long (512 days). The time counters offer seconds, minutes, and hours data in 24-hour time format, which increments in day counts. The prescaler stages are tapped to support sampling timer features. A periodic interrupt at 1Hz is available, as well as an interrupt at the midnight rollover of the hours counter.

13.1.2 Alarm

An alarm is set by accessing the real-time clock alarm (RTCALRM) register and loading the days, hours, minutes and seconds for the time that the alarm is to generate an interrupt. The interrupt is enabled when the AL bit in the real-time clock interrupt enable register (RTCIENR) is set. The alarm is actually posted when the current time matches the time in the RTCIENR.

13.1.3 Watchdog Timer

The watchdog timer uses the 1Hz clock inside the real-time clock module and generates an interrupt or a reset signal to the system every two seconds. You can select an interrupt or reset by programming the watchdog timer (WATCHDOG) register. At reset, the watchdog timer is enabled and the system reset is selected. The resolution of the watchdog timer is one second because of the input frequency. The watchdog timer has to be periodically cleared by software once it is enabled. Otherwise, either a software reset or watchdog interrupt will be generated when the timer reaches a binary value of 10. The counter can be cleared by writing any value into the counter (the high byte of the WATCHDOG register).

13.1.4 Sampling Timer

The sampling timer is designed to support application software. You can choose a frequency from SAMx bits of the RTCIENR register. The sampling timer will generate an interrupt based on that frequency. You can select one of the predefined frequencies as well. You can use this timer for digitizer sampling, keyboard debouncing, or communication polling in your application. The sampling timer only operates if the real-time clock or watchdog timer is enabled. If the sampling timer and watchdog timer are disabled, the real-time clock stops. The following table contains the sampling frequencies of the sampling timer when the primary (32.768kHz) or alternative (38.4kHz) reference clock is chosen.

Table 13-1. Sampling Timer Frequencies

SAMPLING FREQUENCY	32.768KHZ REFERENCE CLOCK	38.4KHZ REFERENCE CLOCK
SAM7	512Hz	600Hz
SAM6	256Hz	300Hz
SAM5	128Hz	150Hz
SAM4	64Hz	75Hz
SAM3	32Hz	37.5Hz
SAM2	16Hz	18.75Hz
SAM1	8Hz	9.375Hz
SAM0	4Hz	4.6875Hz

13.1.5 Minute Stopwatch

The minute stopwatch performs a countdown that has a one minute resolution. It can be used to generate an interrupt after a certain amount of time. For example, the LCD controller can turn off after five minutes of inactivity. The minute stopwatch is programmed for five minutes and then it is enabled. At consecutive minute increments, the minute stopwatch value is decremented. The interrupt is generated when the counter counts to -1. The interrupt occurs after five minutes, in addition to the seconds from the time of setting the stopwatch to the first minute tick.

13.2 PROGRAMMING MODEL

13.2.1 RTC Hours, Minutes, and Seconds Register

The real-time clock hours, minutes, and seconds (RTCTIME) register is used to program the hours, minutes, and seconds. It can be read or written at any time. After a write, the current time assumes the new values. This register cannot be reset since the real-time clock is always enabled at reset.

RTCTIME

BIT	31	30	29	28	27	26	25	24	23	22	21	20	19	18	17	16
FIELD	RESERVED			HOURS					RESERVED			MINUTES				
RESET	0XXXXXXXXX															
ADDR	0xFFFFB00															
BIT	15	14	13	12	11	10	9	8	7	6	5	4	3	2	1	0
FIELD	RESERVED										SECONDS					
RESET	0XXXXXXXXX															
ADDR	0xFFFFB00															

Bits 31–29, 23–22, and 15–6—Reserved

These bits are reserved and should be set to 0.

HOURS

These bits indicate the current hour. They can be set to any value between 0 and 23.

MINUTES

These bits indicate the current minute. They can be set to any value between 0 and 59.

SECONDS

These bits indicate the current second. They can be set to any value between 0 and 59.

13.2.2 RTC Alarm Register

The real-time clock alarm (RTCALRM) register is used to configure the alarm in your design. The hours, minutes, and seconds can be read or written at any time. After a write, the current time assumes the new values.

RTCALRM

BIT	31	30	29	28	27	26	25	24	23	22	21	20	19	18	17	16
FIELD	RESERVED			HOURS					RESERVED			MINUTES				
RESET	0x00000000															
ADDR	0x(FF)FFFB04															
BIT	15	14	13	12	11	10	9	8	7	6	5	4	3	2	1	0
FIELD	RESERVED										SECONDS					
RESET	0x00000000															
ADDR	0x(FF)FFFB04															

Bits 31–29 and 15–6—Reserved

These bits are reserved and should be set to 0.

HOURS

These bits indicate the current setting of the alarm’s hour. They can be set to any value between 0 and 23. Default is 0.

MINUTES

These bits indicate the current setting of the alarm’s minute. They can be set to any value between 0 and 59. Default is 0.

SECONDS

These bits indicate the current setting of the alarm’s second. They can be set to any value between 0 and 59. Default is 0.

13.2.3 Watchdog Timer Register

The watchdog timer (WATCHDOG) register can be used to enable the watchdog timer and provide its status.

WATCHDOG

BIT	15	14	13	12	11	10	9	8	7	6	5	4	3	2	1	0	
FIELD	RESERVED						CNT1	CNT0	INTF	RESERVED						ISEL	EN
RESET	0x0001																
ADDR	0x(FF)FFFB0A																

Real-Time Clock

Bits 15–10 and 6–2—Reserved

These bits are reserved and should remain at their reset value.

CNTx—Counter 1 and 0

These bits represent the status of the watchdog counter. Writing any value to these bits will reset the counter to 00 (default). When the watchdog counter counts to 10, it generates a watchdog interrupt.



Note: The watchdog counter is incremented by a 1Hz signal from the real-time clock, so that the average tolerance of the counter is 0.5sec. To get better accuracy, the watchdog should be handled by polling the 1Hz flag of the RTCISR.

INTF—Interrupt Flag

When this bit is set, a watchdog interrupt has occurred. This bit can be cleared by writing a 1 to it.

- 0 = No watchdog interrupt occurred.
- 1 = A watchdog interrupt occurred.

ISEL—Interrupt Selection

This bit selects the watchdog reset. It is cleared at reset.

- 0 = Select the watchdog reset (default).
- 1 = Select the watchdog interrupt.

EN—Watchdog Timer Enable

This bit enables the watchdog timer. It is set at reset.

- 0 = Disable the watchdog timer.
- 1 = Enable the watchdog timer (default).

13.2.4 RTC Control Register

The real-time clock control (RTCCTL) register is used to control the real-time clock.

RTCCTL

BIT	15	14	13	12	11	10	9	8	7	6	5	4	3	2	1	0
FIELD	RESERVED							EN	RES	XTL	RESERVED					
RESET	0x0080															
ADDR	0x(FF)FFFB0C															

Bits 15–8, 6, and 4–0—Reserved

These bits are reserved and should be set to 0.

EN—Enable

This bit enables the real-time clock.

- 0 = Disable the real-time clock.
- 1 = Enable the real-time clock (default).

XTL—Crystal Selection

- 0 = Reference frequency is 32.768kHz (default).
- 1 = Reference frequency is 38.4kHz.

13.2.5 RTC Interrupt Status Register

The real-time clock interrupt status register (RTCISR) indicates the status of the various real-time clock interrupts. Each bit is set when the corresponding event occurs. You must clear these bits by writing ones, which also clears the interrupt. This register can post interrupts while the system clock is idle or in sleep mode. For more information about the frequency of the sampling timer interrupts, refer to Table 13-1.

RTCISR

BIT	15	14	13	12	11	10	9	8	7	6	5	4	3	2	1	0
FIELD	SAM7	SAM6	SAM5	SAM4	SAM3	SAM2	SAM1	SAM0	RESERVED	HR	1HZ	DAY	ALM	MIN	SW	
RESET	0xXXXX															
ADDR	0x(FF)FFFB0E															

SAM7—Sampling Timer Interrupt Flag at SAM7 Frequency

- 0 = No SAM7 interrupt occurred.
- 1 = A SAM7 interrupt occurred.

SAM6—Sampling Timer Interrupt Flag at SAM6 Frequency

- 0 = No SAM6 interrupt occurred.
- 1 = A SAM6 interrupt occurred.

SAM5—Sampling Timer Interrupt Flag at SAM5 Frequency

- 0 = No SAM5 interrupt occurred.
- 1 = A SAM5 interrupt occurred.

SAM4—Sampling Timer Interrupt Flag at SAM4 Frequency

- 0 = No SAM4 interrupt occurred.
- 1 = A SAM4 interrupt occurred.

SAM3—Sampling Timer Interrupt Flag at SAM3 Frequency

- 0 = No SAM3 interrupt occurred.
- 1 = A SAM3 interrupt occurred.

Real-Time Clock

SAM2—Sampling Timer Interrupt Flag at SAM2 Frequency

0 = No SAM2 interrupt occurred.

1 = A SAM2 interrupt occurred.

SAM1—Sampling Timer Interrupt Flag at SAM1 Frequency

0 = No SAM1 interrupt occurred.

1 = A SAM1 interrupt occurred.

SAM0—Sampling Timer Interrupt Flag at SAM0 Frequency

0 = No SAM0 interrupt occurred.

1 = A SAM0 interrupt occurred.

Bits 7–6—Reserved

These bits are reserved and should remain at their reset value.

HR—Hour Flag

If enabled, this bit is set every hour and an interrupt is posted.

0 = No 1-hour interrupt occurred.

1 = A 1-hour interrupt has occurred.

1HZ—1Hz Flag

If enabled, this bit is set every second and an interrupt is posted.

0 = No 1Hz interrupt occurred.

1 = A 1Hz interrupt has occurred.

DAY—Day Flag

If enabled, this bit is set for every 24-hour clock increment (at midnight) and an interrupt is posted.

0 = No 24-hour rollover interrupt occurred.

1 = A 24-hour rollover interrupt has occurred.

ALM—Alarm Flag

If this bit is enabled, an alarm flag is set on a compare-match between the real time clock and the alarm register's value. You should know, however, that the alarm will reoccur ever 24 hours. If you want a single alarm, you should clear the interrupt enable in the interrupt service routine.

0 = No alarm interrupt occurred.

1 = An alarm interrupt has occurred.

MIN—Minute Flag

If this bit is enabled, a minute flag is set on every minute tick.

- 0 = No 1-minute interrupt occurred.
- 1 = A 1-minute interrupt has occurred.

SW—Stopwatch Flag

If this bit is enabled, the stopwatch flag is set when the stopwatch minute countdown experiences a time-out.

- 0 = The stopwatch did not time out.
- 1 = The stopwatch timed out.

13.2.6 RTC Interrupt Enable Register

The real-time clock interrupt enable register (RTCIENR) is used to enable the interrupt if the corresponding bit is set. For information about the frequency of the sampling timer interrupts, refer to Table 13-1.

REACTION

BIT	15	14	13	12	11	10	9	8	7	6	5	4	3	2	1	0
FIELD	SAM7	SAM6	SAM5	SAM4	SAM3	SAM2	SAM1	SAM0	RESERVED	HR	1HZ	DAY	ALM	MIN	SW	
RESET	0XXXXXXXXX1XXXXXX															
ADDR	0x(FF)FFFB10															

SAM7—Sampling Timer SAM7 Interrupt Enable

This bit enables an interrupt at the SAM7 rate.

- 0 = The SAM7 interrupt is disabled.
- 1 = The SAM7 interrupt is enabled.

SAM6—Sampling Timer SAM6 Interrupt Enable

This bit enables an interrupt at the SAM6 rate.

- 0 = The SAM6 interrupt is disabled.
- 1 = The SAM6 interrupt is enabled.

SAM5—Sampling Timer SAM5 Interrupt Enable

This bit enables an interrupt at the SAM5 rate.

- 0 = The SAM5 interrupt is disabled.
- 1 = The SAM5 interrupt is enabled.

Real-Time Clock

SAM4—Sampling Timer SAM4 Interrupt Enable

This bit enables an interrupt at the SAM4 rate.

- 0 = The SAM4 interrupt is disabled.
- 1 = The SAM4 interrupt is enabled.

SAM3—Sampling Timer SAM3 Interrupt Enable

This bit enables an interrupt at the SAM3 rate.

- 0 = The SAM3 interrupt is disabled.
- 1 = The SAM3 interrupt is enabled.

SAM2—Sampling Timer SAM2 Interrupt Enable

This bit enables an interrupt at the SAM2 rate.

- 0 = The SAM2 interrupt is disabled.
- 1 = The SAM2 interrupt is enabled.

SAM1—Sampling Timer SAM1 Interrupt Enable

This bit enables an interrupt at the SAM1 rate.

- 0 = The SAM1 interrupt is disabled.
- 1 = The SAM1 interrupt is enabled.

SAM0—Sampling Timer SAM0 Interrupt Enable

This bit enables an interrupt at the SAM0 rate.

- 0 = The SAM0 interrupt is disabled.
- 1 = The SAM0 interrupt is enabled.

Bits 7–6—Reserved

These bits are reserved and should remain at their reset value.

HR—Hour Interrupt Enable

This bit enables an interrupt at a 1-hour rate.

- 0 = The 1-hour interrupt is disabled.
- 1 = The 1-hour interrupt is enabled.

1HZ—1Hz Interrupt Enable

This bit enables an interrupt at a 1Hz rate.

- 0 = The 1Hz interrupt is disabled.
- 1 = The 1Hz interrupt is enabled.

DAY—Day Interrupt Enable

If enabled, this bit is set for every 24-hour clock increment (at midnight) and an interrupt is posted. This bit enables an interrupt at midnight rollover.

- 0 = The 24-hour interrupt is disabled.
- 1 = The 24-hour interrupt is enabled.

ALM—Alarm Interrupt Enable

This bit enables the alarm interrupt.

- 0 = The alarm interrupt is disabled.
- 1 = The alarm interrupt is enabled.

MIN—Minute Interrupt Enable

This bit enables the interrupt at a 1-minute rate.

- 0 = The 1-minute interrupt is disabled.
- 1 = The 1-minute interrupt is enabled.

SW—Stopwatch Interrupt Enable

This bit enables the stopwatch interrupt.

- 0 = The 1-minute interrupt is disabled.
- 1 = The 1-minute interrupt is enabled.



Note: The stopwatch counts down and remains at decimal -1 until it is reprogrammed. If this bit is enabled with -1 (decimal) in the STPWCH register, an interrupt will be posted on the next minute tick.

13.2.7 Stopwatch Minutes Register

The stopwatch minutes (STPWCH) register contains the current stopwatch countdown value.

STPWCH

BIT	15	14	13	12	11	10	9	8	7	6	5	4	3	2	1	0
FIELD	RESERVED										CNT					
RESET	0x003F															
ADDR	0xFFFFB12															

Bits 15–6—Reserved

These bits are reserved and should remain at their reset value.

CNT—Stopwatch Count

This field contains the stopwatch countdown value. The highest possible value is 62 minutes. The countdown will not be activated again until a nonzero value, which is less than 63 minutes, is written to this register.



Note: The stopwatch counter is decremented by the minute (MIN) tick output from the real-time clock, so the average tolerance of the count is 0.5 minutes. To get better accuracy, you should enable the stopwatch by polling the MIN bit of the RTCISR register or by polling the minute interrupt service routine.

13.2.8 RTC Day Count Register

The real-time clock day count register (DAYR) contains the data from the day counter. When the hours counter gets to 24, the day counter will increment. This register can be read or written at any time. After a write, the current day assumes the new values. This register cannot be reset since the real-time clock is always enabled at reset.

DAYR

BIT	15	14	13	12	11	10	9	8	7	6	5	4	3	2	1	0
FIELD	RESERVED							DAYS								
RESET	0x0XXX															
ADDR	0x(FE)FFFB1A															

Bits 15–9—Reserved

These bits are reserved and should remain at their reset value.

DAYS—Day Setting

This field indicates the current setting of the day. It can be set to any value between 0 and 511.

13.2.9 RTC Day Alarm Register

The real-time clock day alarm (DAYALARM) register is used to configure the day for the alarm. It can be read or written at any time. After a write, the current time assumes the new values.

DAYALARM

BIT	15	14	13	12	11	10	9	8	7	6	5	4	3	2	1	0
FIELD	RESERVED							DAYSAL								
RESET	0x0000															
ADDR	0x(FE)FFFB1C															

Bits 15–9—Reserved

These bits are reserved and should remain at their reset value.

DAYSAL—Day Setting of the Alarm

This field indicates the current setting of the alarm's day. It can be set to any value between 0 (default) and 511.

SECTION 14 DRAM CONTROLLER

The DRAM controller is a glueless interface to 8-bit or 16 bit DRAM. It supports a maximum of two banks of DRAM using the $\overline{CSD0}$ and $\overline{CSD1}$ signals. The DRAM controller provides row address strobe (\overline{RAS}) and column address strobe (\overline{CAS}) signals for these two banks of DRAM. The DRAM controller has the following features:

- 68EC000 zero wait-state operation support
- \overline{CAS} -before- \overline{RAS} refresh cycles and self-refresh mode DRAM support
- 8- and 16-bit port DRAM support
- Fast page and EDO modes for LCD DMA access cycles
- Programmable refresh rate
- Maximum of two banks of DRAM are supported
- Programmable row and column address size with symmetrical or asymmetrical addressing
- 256Kx16, 512Kx8, 512Kx16, 1Mx8, 1Mx16, 4Mx8, or 4Mx16 DRAM is supported

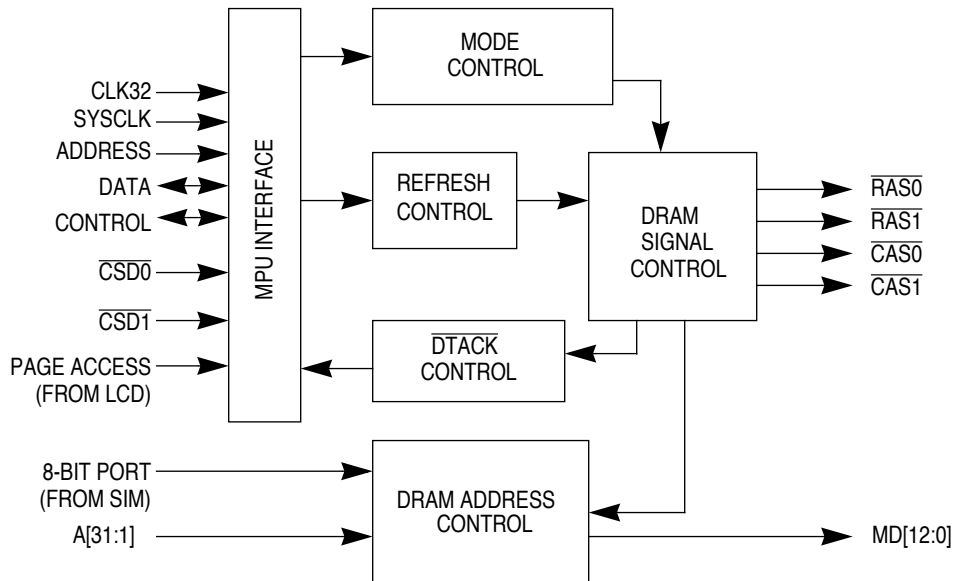

Figure 14-1. DRAM Controller Block Diagram

14.1 OPERATION

14.1.1 Address Multiplexing

The address multiplexer can support a wide variety of memory devices in 8- or 16-bit mode. The upper internal address lines from the core or LCD controller are the row address and the lower internal address lines are the column address. This scheme enables you to use Fast-Page or EDO mode read accesses to the DRAM during LCD DMA cycles. For 4M (512Kx8) DRAM, there are usually only 10 row addresses and 9 column addresses. However, the DRAM multiplexor supports different row/column configurations, depending on the arrangement of the DRAM rows and columns and the data port size (8- or 16-bit) of the DRAM.

To use 512Kx8 DRAMs in 8-bit mode, you need the internal address bus PA[8:0] for column addresses and PA[18:9] for row addresses. However, in 16-bit mode, the column addresses need PA[9:0] and the row addresses need PA[19:10]. The MC68EZ328's DRAM controller uses PA[8:0] as the column addresses for MD[7:0] and allows the software to select PA0 or PA9 for column address MD8. Similar address selection options are provided for MD9 and MD10 column addresses, the MD0 row address, and MD8 through MD12 row addresses.

The MD[12:0] signals share the same address pins that output as non-multiplexed addresses A[13:1] for non-DRAM external accesses. Since the internal addresses (PA[13:1]) are present as the column address selection from the DRAM address multiplexer, these addresses may be used as the non-multiplexed addresses A[13:1] for non-DRAM external accesses. This simplifies the overall multiplexing scheme for the MC68EZ328. However, it is important to note that the A0 signal is not used as a DRAM address pin connection.

The following table contains the address multiplexing options that are available when you program the DRAM memory configuration (DRAMMC) register.

Figure 14-2. DRAM Address Multiplexer Options

ROW ADDRESS OPTIONS	PA23, PA22, PA11	PA12	PA13	PA14	PA15	PA16	PA17	PA18	PA10, PA20	PA9, PA19	PA19, PA21	PA20, PA22	PA10, PA21, PA23
COLUMN ADDRESS OPTIONS	PA1	PA2	PA3	PA4	PA5	PA6	PA7	PA8	PA0, PA9	PA0, PA10	PA0, PA11	PA12*	PA13*
MD ADDRESS	MD0	MD1	MD2	MD3	MD4	MD5	MD6	MD7	MD8	MD9	MD10	MD11	MD12
SIGNAL	A1/ MD0	A2/ MD1	A3/ MD2	A4/ MD3	A5/ MD4	A6/ MD5	A7/ MD6	A8/ MD7	A9/ MD8	A10/ MD9	A11/ MD10	A12/ MD11	A13/ MD12

NOTE: PA12 and PA13 are "don't care" bits for the DRAM controller column addresses, but A12 and A13 are used by the external signal pins for non-DRAM accesses.

14.1.2 \overline{DTACK} Generation

For a 16MHz system frequency, 60ns DRAM can support a zero wait-state (four clocks per access) for EC000 bus cycles. Therefore, \overline{DTACK} will only be delayed for refresh operations that occur before a read/write access cycle. N clocks (N is the number of system clock cycles required for refresh) will be inserted into a read or write cycle when the EC000 cycle collides with a refresh cycle. Refresh, in this case, has a higher priority.



Note: N can be 1–4 clocks, depending on the collision overlap of the refresh and EC000 bus cycle.

14.1.3 Refresh Control

During normal operation, the MC68EZ328 DRAM cycles are distributed evenly over the refresh period. DRAM refresh rate requirements vary between different DRAM chips. The DRAM configuration register is used to program the required refresh frequency.

For example:

- At 32.768kHz, CLK=0, register value = 0, therefore the refresh period = 15.2 μ s.
- Using a Sysclk of 16.58kHz, CLK=1, register value(REF) = 7, then refresh period = 15.44 μ s.

14.1.4 LCD Interface

The DRAM controller supports page bursting accesses. When the PAGE_ACCESS signal is active and $\overline{CSD}[1:0]$ is active, fast page or EDO mode will be initiated. You can program the fast page mode access clock for second and onward accesses using the BC0 and BC1 bits of the DRAMC register. The DRAM controller will support 4,1,1,1,1,....., 4,2,2,2,2,..... or 4,3,3,3,3,..... access for LCD controller burst accesses. Single clocks/transfers are only supported in EDO mode, which allows for the fastest LCD DMA transfers. However, in EDO mode, the BC0 and BC1 bits are ignored by the DRAM controller.

When an LCD controller cycle and a refresh request collide before the LCD controller cycle starts, refresh will go first, and N more clocks will be added to the first access (N is the number of system clock cycles required for refresh). Therefore, for a 4-1-1-1-1-... cycle, the access will become (4+N),1,1,1,1,.....

When a consecutive LCD controller burst access crosses a memory page boundary, the DRAM controller will hold the LCD controller that is negating the internal \overline{DTACK} signal to change the row address and wait for a precharge time, (4-1-1-1-1-...-1-1-4-1-1-1-1-...-1-1-1). When a refresh request occurs in the middle of a LCD controller cycle transfer, refresh will be deferred until the end of the LCD controller cycle. Since the LCD controller cycle will only last for eight cycles, deferring the refresh cycle will not overlap with the next refresh request.

The \overline{DTACK} signal is used to hold the LCD controller after the address changes on each word of an LCD transfer. If \overline{DTACK} is asserted, the LCD controller will assume a fixed

wait-state transfer per the setup within the LCD controller. The LCD controller will hold as long as DTACK is not asserted.

The PAGE_ACCESS signal from the LCD controller indicates to the DRAM controller and system integration module that a LCD DMA burst transfer is about to begin. The associated chip-select signal will hold active throughout the LCD controller's access cycle. In this mode, the DRAM controller supports page accesses.

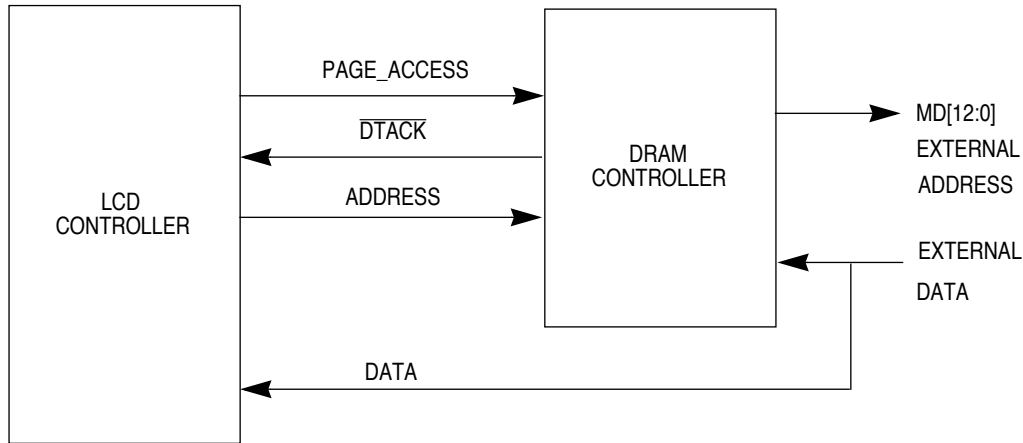

Figure 14-3. LCD Controller and DRAM Controller Interface

14.1.5 8-Bit Mode

You can select 8-bit operation on-the-fly with the signal 8-bit port from the system integration module. If one of the \overline{CSDx} signals are programmed as 8-bit mode, the 8-bit mode signal will be active at the same time that \overline{CSDx} is active. In 8-bit mode, the DRAM address multiplexer will use PA0 as the least-significant multiplexed address, instead of PA1, and the remainder of the multiplexed address lines will be adjusted to fit the 8-bit operation of the selected DRAM device. \overline{RAS} , \overline{CAS} , and refresh signal functions will remain the same. Depending on the DRAM type, your system software may need to adjust the address multiplexer options in the DRAMMC register.

14.1.6 Low-Power Standby Mode

If you are using a DRAM that can support self-refresh mode, you can program the RM bit in the DRAMC register to self-refresh mode before you enter sleep mode. The DRAM controller will generate one \overline{CAS} -before- \overline{RAS} cycle, negate \overline{RAS} and \overline{CAS} for the required precharge time, then assert \overline{CAS} -before- \overline{RAS} and continue to assert them until the mode is changed in the RM bit. DRAMs that support self-refresh mode will enter self-refresh typically 100 μ s after \overline{RAS} and \overline{CAS} are held in the asserted state. After wake-up, one \overline{CAS} -before- \overline{RAS} refresh cycle will occur and then normal mode operation will continue.

For DRAMs without self-refresh mode, you should set the LPR bit in the DRAMC register for \overline{CAS} -before- \overline{RAS} refresh mode to continue while the processor is shut down and all other modules are disabled.

14.1.7 Data Retention During Reset

DRAM needs to retain data during reset, which is external reset or internal watchdog reset. Figure 14-4 illustrates the timing for data retention.

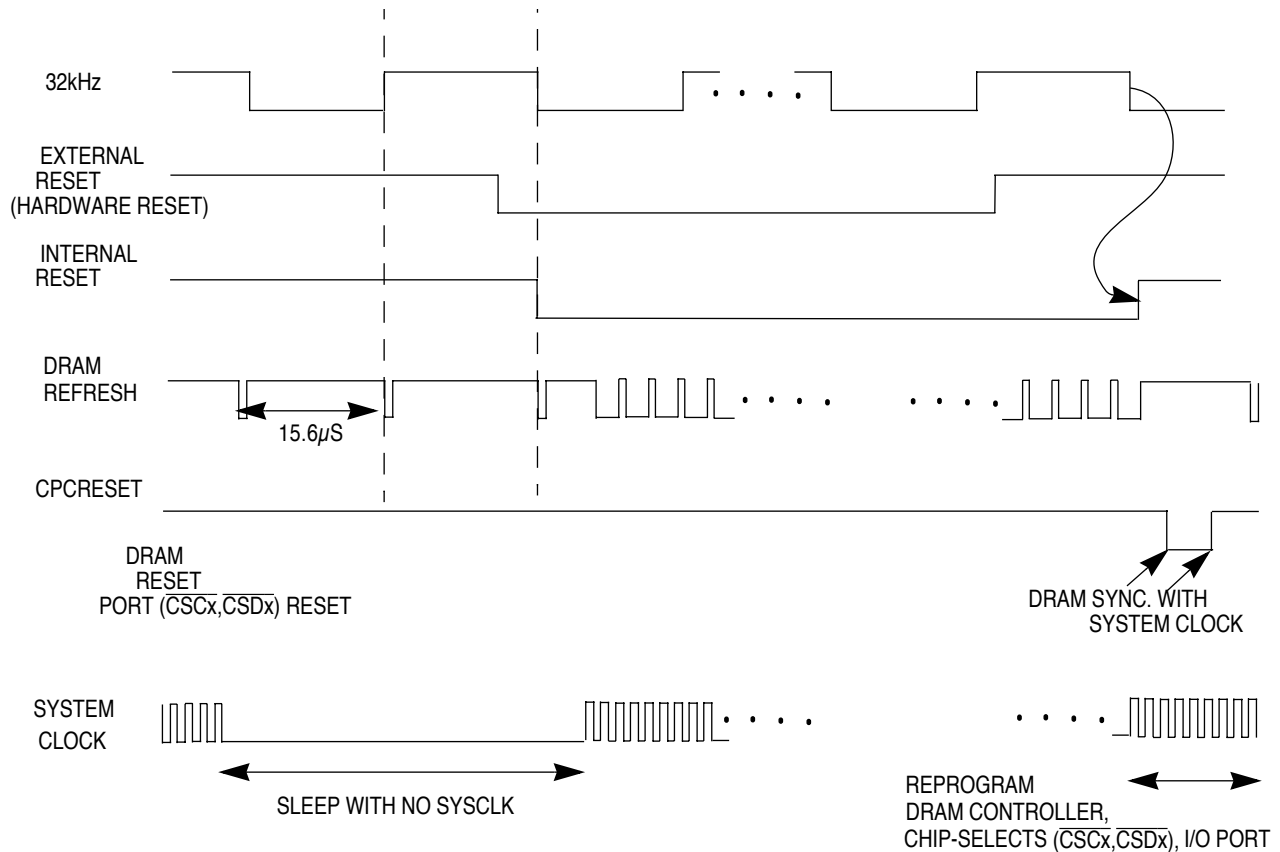

Figure 14-4. Data Retention for the Reset Cycle

Data is retained in the following sequence:

1. The external $\overline{\text{RESET}}$ signal is sent to the MC68EZ328.
2. The internal $\overline{\text{RESET}}$ signal is generated by synchronizing the external $\overline{\text{RESET}}$ signal with the CLK32 signal.
3. When the internal $\overline{\text{RESET}}$ is asserted, the DRAM controller will stop the current refresh operation and enters burst refresh mode, which is a consecutive $\overline{\text{CAS}}$ -before- $\overline{\text{RAS}}$ refresh cycle.
4. The external $\overline{\text{RESET}}$ signal continues asserting.
5. The external $\overline{\text{RESET}}$ signal is negated.
6. The internal $\overline{\text{RESET}}$ signal is negated.
7. The DRAM controller terminates the burst $\overline{\text{CAS}}$ -before- $\overline{\text{RAS}}$ refresh cycle.
8. The internal CPCRESET signal is generated for four clocks to reset the DRAM

DRAM Controller

controller and the $\overline{\text{CSCx}}$ and $\overline{\text{CSDx}}$ port signals.

9. The chip is now reset.
10. The core processor programs the DRAM controller and the port pins after this reset to resume DRAM controller operation.



Note: The initialization code should program or initialize the DRAM controller and the general-purpose I/O port signals within the DRAM's specified refresh time.

14.2 PROGRAMMING MODEL

14.2.1 DRAM Memory Configuration Register

The DRAM memory configuration register (DRAMMC) is used to set the DRAM refresh interval and configure the address multiplexer for your specific memory device.

DRAMMC

BIT	15	14	13	12	11	10	9	8	7	6	5	4	3	2	1	0
FIELD	ROW12		ROW0		ROW1 1	ROW1 0	ROW9	ROW8	COL10	COL9	COL8	REF				
RESET	0x0000															
ADDR	0x(FE)FFFC00															

ROW 12

This field selects the row address bit for multiplexed address MD12.

- 00 = PA10.
- 01 = PA21.
- 10 = PA23.
- 11 = Not valid.

ROW 0

This field selects the row address bit for multiplexed address MD0.

- 00 = PA11.
- 01 = PA22.
- 10 = PA23.
- 11 = Not valid.

ROW 11

This bit selects the row address bit for multiplexed address MD11.

- 0 = PA20.
- 1 = PA22.

ROW 10

This bit selects the row address bit for multiplexed address MD10.

0 = PA19.

1 = PA21.

ROW 9

This bit selects the row address bit for multiplexed address MD9.

0 = PA9.

1 = PA19.

ROW 8

This bit selects the row address bit for multiplexed address MD8.

0 = PA10.

1 = PA20.

COL 10

This bit selects the column address bit for multiplexed address MD10.

0 = PA11.

1 = PA0.

COL 9

This bit selects the column address bit for multiplexed address MD9.

0 = PA10.

1 = PA0.

COL 8

This bit selects the column address bit for multiplexed address MD8.

0 = PA9.

1 = PA0.

REF—Refresh Cycle

This value determines the refresh rate for the DRAM controller. The refresh rate can be calculated using the following equation. The value is the time for one refresh cycle.

When CLK=0, 32KHz (or 34.8 KHz) is used for refresh control

REF = 0, refresh rate = 2 x 32kHz.

REF = 1, refresh rate = 32 KHz

REF = 2 to 15, refresh rate = 32KHz / (REF+1)

When CLK=1, the system clock is used for refresh control

Refresh rate = sysclk/[32 x (REF+1)]

14.2.2 DRAM Control Register

The DRAM control (DRAMC) register is used to control the operation of the DRAM controller.

DRAMC

BIT	15	14	13	12	11	10	9	8	7	6	5	4	3	2	1	0
FIELD	EN	RM	BC1	BC0	CLK	EDO	PGSZ		WS1	WS0	MSW	LSP	SLW	LPR	RST	DWE
RESET	0x0000															
ADDR	0x(FF)FFFC02															

EN—Enable

This bit enables and disables the DRAM controller.

- 0 = Disable the DRAM controller.
- 1 = Enable the DRAM controller.

RM—Refresh Mode

This bit sets the refresh mode.

- 0 = $\overline{\text{CAS}}$ -before- $\overline{\text{RAS}}$ refresh mode.
- 1 = Self-refresh mode.

BC1 and BC0—Page Access Clock Cycle (Fast Page Mode)

These bits determine the number of additional clocks for each access within a fast page read cycle after the first data word.

- 00 = One clock (2 clocks/transfer).
- 01 = Two clocks (3 clocks/transfer).
- 10 = Three clocks (4 clocks/transfer).
- 11 = Four clocks (5 clocks/transfer).



Note: The first fast page access will always be four clocks. When a refresh request hits the LCD cycle at the beginning, the first access will become 4+N. N is the number of refresh clocks.

CLK—Clock

This bit selects the clock that is provided to the refresh timer.

- 0 = 32kHz (Period A) is selected.
- 1 = System clock(Period B) is selected.

EDO—Extended Data Out

This bit selects the page access mode for LCD DMA DRAM accesses. This bit should only be set if the DRAM supports EDO transfers. When EDO is set, BC0, and BC1 do not affect the number of clocks for LCD DMA DRAM accesses. EDO mode is the fastest LCD DMA transfer mode.

0 = Fast page mode is selected.

1 = EDO enables one clock for each LCD DMA data word transfer after the first word transfer.

PGSZ—Page Size

This field determines the page size for fast page mode.

00 = 256K.

01 = 512K.

10 = 1,024K.

11 = 2,048K.

WSx—Wait-States 1 and 0

These bits determine the number of wait-states for core accesses to DRAM.

00 = No wait-states.

01 = One wait-state.

10 = Two wait-states.

11 = Three wait-states.

MSW—Slow Multiplexing

Setting this bit adds a half system clock cycle for DRAM address multiplexing, which allows for a heavily loaded A/MAD bus. Setting this bit causes an additional wait-state for all core accesses and the first LCD DMA word access.

0 = Normal address multiplexing.

1 = Slower address multiplexing.

LSP—Light Sleep

Setting this bit enables the core or LCD controller to access the DRAM when the RM bit is set (DRAM in self-refresh mode). Self-refresh mode is temporarily interrupted for the DRAM access and automatically returns to self-refresh mode once the transfer is complete.

Transfers in this mode are much slower than normal. Therefore, it is best to clear the RM bit if the DRAM is to be awake for extended periods of time. If this bit is clear, DRAM accesses will not occur when RM is set and attempts will cause the bus to time-out.

0 = Self-refresh is interrupted only by clearing the RM bit.

1 = Self-refresh is temporarily interrupted by the core or LCD controller accesses to DRAM.

DRAM Controller

SLW—Slow RAM

Setting this bit extends the $\overline{\text{RAS}}$ precharge period for slower DRAM devices. You should set this bit if the $\overline{\text{RAS}}$ precharge time requirement for the device you are using is greater than 50ns (20MHz system clock) or 60ns (16.58MHz system clock). Typically, DRAMs with a faster access time than 100ns will not require the additional precharge time.

- 0 = Normal $\overline{\text{RAS}}$ precharge.
- 1 = Extended $\overline{\text{RAS}}$ precharge for slower DRAM devices.

LPR—Low-Power Refresh Enable

This bit is used to control the refresh during low-power modes.

- 0 = Disable low-power refresh mode.
- 1 = Enable low-power refresh mode.

RST—Reset Burst Refresh Enable

This bit controls the refresh type during $\overline{\text{RESET}}$ assertion.

- 0 = Normal distributed refresh operation during DRAM reset function.
- 1 = Continuous burst refresh operation during DRAM reset function.

DWE—DRAM Write Enable

This bit is used to enable the $\overline{\text{DWE}}$ signal, which can be used when you are using a DRAM that needs an independent write-enable signal, rather than sharing one with the $\overline{\text{UWE}}$ signal.

- 0 = Disable $\overline{\text{DWE}}$.
- 1 = Enable $\overline{\text{DWE}}$.

SECTION 15 IN-CIRCUIT EMULATION

The in-circuit emulation (ICE) module is designed to support low-cost emulator designs for the MC68EZ328 microprocessor. It uses four interface signals that are extended to the pins. The in-circuit emulation module uses some of the 68K resources with minimal restrictions. The features of the in-circuit emulation module are as follows:

- Dedicated chip-select for emulator debug monitor (using the $\overline{\text{EMUCS}}$ signal)
- Dedicated interrupt (level 7) for in-circuit emulation
- One address signal comparator and one control signal comparator with masking to support single or multiple hardware execution/bus breakpoints
- One breakpoint instruction insertion unit

Figure 15-1 illustrates the block diagram of the in-circuit emulation module.

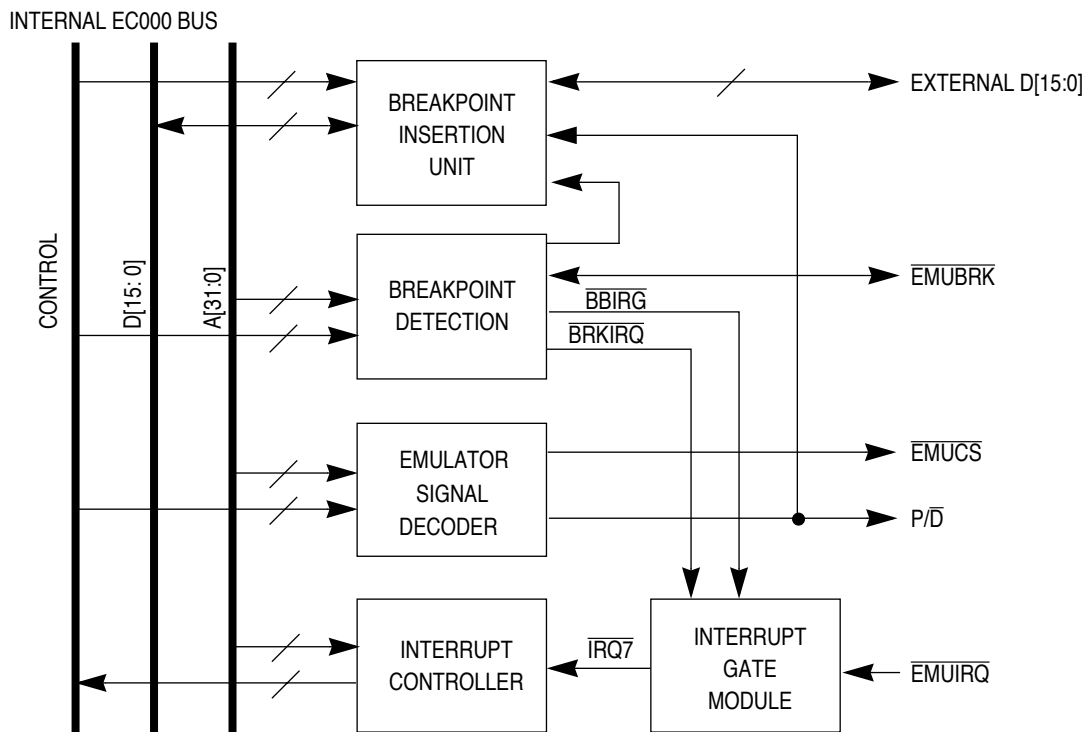

Figure 15-1. In-Circuit Emulation Module Block Diagram

15.1 OPERATION

In-circuit emulation module operation consists of the following tasks:

- Entering emulation mode
- Detecting breakpoints
- Using the signal decoder
- Using the interrupt gate module
- Using the A-line insertion unit

15.1.1 Entering Emulation Mode

The in-circuit emulation module latches the state of the $\overline{\text{EMUIRQ}}$ signal on the rising edge of the $\overline{\text{RESET}}$ signal. To put the MC68EZ328 in emulation mode, you must externally drive the $\overline{\text{EMUIRQ}}$ signal low during system reset. After system reset, $\overline{\text{EMUIRQ}}$ becomes a falling edge trigger signal, which will generate a level 7 interrupt when active. For emulation mode, the $\overline{\text{CSA0}}$ signal is not asserted for reset fetch, as it is in normal operation mode. The in-circuit emulation module internally generates a reset vector to the processor on reset vector fetch cycles.

This hard-coded reset vector is $\text{PC} = 0\text{xFFFC0020}$ and $\text{SSP} = 0\text{xFFFCFFFC}$, which means that the monitor or bootcode must start at 0xFFFC0020 . The $\overline{\text{EMUCS}}$ signal is designed to cover system memory space from 0xFFFC0000 to 0xFFFDFFFF and it is an 8-bit data bus width chip-select signal. If $\overline{\text{EMUIRQ}}$ is logic high during system reset, the in-circuit emulation module is disabled and the MC68EZ328 begins another operation mode.

15.1.2 Detecting Breakpoints

The execution breakpoint detector has one 32-bit address comparator and one control signals comparator. When you configure the in-circuit emulation module to be in single breakpoint mode, in which $\overline{\text{EMUBRK}}$ is an output, the generation of the $\overline{\text{EMUBRK}}$ signal is internally qualified by the $\overline{\text{AS}}$ signal. The active time for this signal will vary, depending on the setting and width (wait-state) of the bus cycle. The $\overline{\text{EMUBRK}}$ signal is asserted throughout the address matched cycle. When the in-circuit emulation module is in multiple breakpoint mode, $\overline{\text{EMUBRK}}$ is an input that is asserted by the external address comparator. The external address comparator will compare the lower address while the internal comparator with masking compares the hidden address signals. The $\overline{\text{EMUBRK}}$ signal, together with the internal compare result, will generate the match signal to the breakpoint insertion unit.

Since the processor does not have built-in emulation support, execution breakpoint is implemented external to the core and will use the A-line instruction and level 7 interrupt. To accurately catch the execution breakpoint, the in-circuit emulation module inserts the 0xA000 opcode at the location where a breakpoint is set. For more information regarding the insertion mechanism, refer to [Section 15.1.5 Using the A-Line Insertion Unit](#). When the 0xA000 opcode is being executed, which means the breakpoint is reached, an exception vector fetch for an A-line exception will occur. At this point, $\overline{\text{EMUBRK}}$ is asserted to stop the process and switch control to the emulation monitor (selected by the $\overline{\text{EMUCS}}$ signal).

An exception vector fetch for A-line exception are two consecutive word reads at addresses 0x28 and 0x2A. The A-line exception vector fetch will cause an $\overline{\text{IRQ7}}$ assertion if a breakpoint is activated in emulation mode. However, normal memory reads to these two words will not cause an $\overline{\text{IRQ7}}$ assertion.

15.1.2.1 EXECUTION BREAKPOINTS VERSUS BUS BREAKPOINTS. An execution breakpoint is a breakpoint at which the current program execution will stop and give control to the monitor. To set up a single execution breakpoint, initialize the compare and mask registers, set the SB, PBEN, and CEN bits in the in-circuit emulation module control register (ICEMCR), then clear the BBIEN and HMDIS bits in the same register. For multiple execution breakpoint mode, clear the SB bit. A bus breakpoint is an address to stop when there is a memory write or read at this address location. To enter single bus breakpoint mode, set the SB, BBIEN, and CEN bits, and then clear the PBEN and HMDIS bits. For multiple bus breakpoint mode, clear the SB bit.

15.1.3 Using the Signal Decoder

The emulator requires a local resident debug monitor to be mapped at a specific location that is transparent to you, the user. This monitor resides in a dedicated memory space 0xFFFC0000–0xFFFCFFFF (64K), which is selected by the $\overline{\text{EMUCS}}$ signal with internal $\overline{\text{DTACK}}$ generation. In emulation mode, the respected memory map is reserved for the emulator and you should not assign any memory to this area. The port size of this monitor is 8-bit and the data bus is D[15:8].

The $P/\overline{\text{D}}$ signal indicates the characteristics of the current cycle. A zero indicates a data access cycle ($\text{FC}[2:0] = \text{x01}$), a one indicates a program access ($\text{FC}[2:0] = \text{x10}$). The emulator uses this signal to disassemble assembly code during trace.

15.1.4 Using the Interrupt Gate Module

There are three level 7 interrupt sources: two are internal and one is external. An internal level 7 interrupt is generated, if it is enabled, when a program or bus breakpoint is hit. An external level 7 interrupt is directly connected to the $\overline{\text{EMUIRQ}}$ pin, which is a falling edge trigger signal. The level 7 interrupt vector is hard-coded to 0xFFFC0010 if the HMDIS bit in the ICEMCR register is clear. If HMDIS is set, refer to for information about generating a level 7 interrupt vector number.

When there is a level 7 interrupt, the software needs to check the in-circuit emulation module status register (ICEMSR) to determine the source of the interrupt. Each of these interrupts can be cleared by writing a one to the associated status bit. If the in-circuit emulation module is disabled, the $\overline{\text{EMUIRQ}}$ pin is the only source for level 7 interrupts.

15.1.5 Using the A-Line Insertion Unit

The A-line insertion unit will physically replace the data bus contents with 0xA000 in an instruction fetch cycle when the address of this bus cycle matches the breakpoint address. When an A-line insertion occurs, the in-circuit emulation module will wait for an A-line exception to occur. If an A-line exception occurs, a level 7 interrupt is generated to the signal that a program breakpoint hits.

15.2 PROGRAMMING MODEL

15.2.1 In-Circuit Emulation Module Address Compare/Mask Registers

The in-circuit emulation module address compare register (ICEMACR) is used to store the address of the breakpoint and the in-circuit emulation module address mask register (ICEMAMR) is used to mask the corresponding address bit in the ICEMACR. The in-circuit emulation module's address comparator will compare the address bus value together with the control bus value to generate the \overline{EMUBRK} signal. A range can be set by using the address mask bits to break in a range of memory so that the external address comparator can take action if extra hardware breakpoints are needed.

ICEMACR

BIT	31	30	29	28	27	26	25	24	23	22	21	20	19	18	17	16
FIELD	AC31	AC30	AC29	AC28	AC27	AC26	AC25	AC24	AC23	AC22	AC21	AC20	AC19	AC18	AC17	AC16
RESET	0x0															
ADDR	0x(FF)FFFFFFD00															
BIT	15	14	13	12	11	10	9	8	7	6	5	4	3	2	1	0
FIELD	AC15	AC14	AC13	AC12	AC11	AC10	AC9	AC8	AC7	AC6	AC5	AC4	AC3	AC2	AC1	AC0
RESET	0x0															
ADDR	0x(FF)FFFFFFD00															

ICEMAMR

BIT	31	30	29	28	27	26	25	24	23	22	21	20	19	18	17	16
FIELD	AM31	AM30	AM29	AM28	AM27	AM26	AM25	AM24	AM23	AM22	AM21	AM20	AM19	AM18	AM17	AM16
RESET	0x0															
ADDR	0x(FF)FFFFFFD04															
BIT	15	14	13	12	11	10	9	8	7	6	5	4	3	2	1	0
FIELD	AM15	AM14	AM13	AM12	AM11	AM10	AM9	AM8	AM7	AM6	AM5	AM4	AM3	AM2	AM1	AM0
RESET	0x0															
ADDR	0x(FF)FFFFFFD04															

ACx—Address Compare 31-0

These bits represents the value of the execution/bus breakpoint address. A match of address bits 31-0 with qualification of \overline{AS} will generate a match signal.

AMx—Address Mask 31-0

These bits mask the corresponding bits in the ACx field. With this masking scheme, a break can be made when the core is accessing a certain range of addresses.

- 0 = The address is compared to the current address cycle.
- 1 = Forces a true comparison (“don’t care”) on the corresponding bit.

15.2.2 In-Circuit Emulation Module Control Compare/Mask Register

The in-circuit emulation module control compare (ICEMCCR) register is used to set the breakpoint at a specific bus cycle and the in-circuit emulation module control mask register (ICEMCMR) is used to mask the corresponding control bit in the ICEMCMR. In bus breakpoint mode, the control signal comparator will compare the predefined control signals with the address compare match signal to generate the \overline{EMUBRK} signal in single breakpoint mode. In a multi-breakpoint mode, \overline{EMUBRK} is an input signal and will “AND” with the result from the address comparator and control comparator to generate the internal match signal. For program break mode, these two registers are don’t care.

ICEMCCR

BIT	15	14	13	12	11	10	9	8	7	6	5	4	3	2	1	0
FIELD	RESERVED														RW	PD
RESET	0x0															
ADDR	0x(FF)FFFFFFD08															

Bits 15–2—Reserved

RW—Read/Write Cycle Selection

This bit is used to select the break at a read cycle or write cycle. When a break at read cycle is selected, a breakpoint at the ROM location is possible.

- 0 = Write cycle breakpoint.
- 1 = Read cycle breakpoint.

PD—Program/Data Cycle Selection

This bit is used to select the break at a program or data cycle.

- 0 = Data bus cycle.
- 1 = Instruction bus cycle.

In-Circuit Emulation

ICEMCMR

BIT	15	14	13	12	11	10	9	8	7	6	5	4	3	2	1	0
FIELD	RESERVED														RWM	PDM
RESET	0x0															
ADDR	0x(FF)FFFFFFD0A															

Bits 15–2—Reserved

These bits are reserved and should be set to 0.

RWM—Read/Write Cycle Mask

This bit masks the RW bit of the ICEMCCR.

0 = Enable the comparator to compare itself against the RW bit.

1 = Force a true comparison (“don’t care”) on the corresponding bit.

PDM—Program Data/Cycle Mask

This bit masks the PD bit of the ICEMCCR.

0 = Enable the comparator to compare itself against the PD bit.

1 = Force a true comparison (“don’t care”) on the corresponding bit.

15.2.3 In-Circuit Emulation Module Control Register

The in-circuit emulation module control register (ICEMCR) is used to control the in-circuit emulation module.

ICEMCR

BIT	15	14	13	12	11	10	9	8	7	6	5	4	3	2	1	0
FIELD	RESERVED											BBIEN	HMDIS	SB	PBEN	CEN
RESET	0x0															
ADDR	0x(FF)FFFFFFD0C															

Bits 15–5—Reserved

These bits are reserved and should be set to 0.

BBIEN—Bus Break Interrupt Enable

0 = Disable level 7 interrupt generation on a bus breakpoint.

1 = Enable level 7 interrupt generation on a bus breakpoint.

HMDIS—Hardmap Disable

In emulation mode, this bit is used to activate the internal hardmap operation. When this bit is clear, some memory locations are hard-coded to the specific values shown in the table below. If this bit is set or in normal mode, memory read to these locations refers to the external memory. It is important to note that when you are writing to these locations, you are writing to external memory. When the HMDIS bit is disabled, reads to these addresses are in word or long-word sizes.

ADDRESS	HARD-CODE
0x0	0xFFFC
0x2	0xFFFC
0x4	0xFFFC
0x6	0x0020
0x28	0xFFFC
0x2A	0x0010
(IRQ7 vector upper word)	0xFFFC
(IRQ7 vector lower word)	0x0010

SB—Single Breakpoint

This bit controls the direction of the $\overline{\text{EMUBRK}}$ signal. In multi-breakpoint mode, the external address comparator will compare the lower address bits and the internal comparator will compare the higher address bits to generate a breakpoint matched signal.

- 0 = Configure the $\overline{\text{EMUBRK}}$ signal as an input (multiple breakpoint mode with external address compare for the lower addresses).
- 1 = Configure the $\overline{\text{EMUBRK}}$ signal as an output (single breakpoint based on the internal address compare register).

PBEN—Program Break Enable

This bit is used to select a program or bus break.

- 0 = Select a bus break.
- 1 = Select a program break.

CEN—Compare Enable

This bit is used to activate the comparison logic. You should program the address compare and mask registers before setting this bit to valid.

- 0 = Disable the breakpoint comparison logic.
- 1 = Enable the breakpoint comparison logic.

15.2.4 In-Circuit Emulation Module Status Register

The in-circuit emulation module status register (ICEMSR) is used to determine the source of an interrupt.

ICEMSR

BIT	15	14	13	12	11	10	9	8	7	6	5	4	3	2	1	0
FIELD	RESERVED												EMIRQ	BBIRQ	BRKIRQ	EMUEN
RESET	0x0															
ADDR	0xFFFFFFFFD0E															

Bits 15–4—Reserved

These bits are reserved and should be set to 0.

EMIRQ— $\overline{\text{EMUIRQ}}$ Falling Edge Detected

This bit is set when the $\overline{\text{EMUIRQ}}$ pin is going from high to low. Writing a 1 to this bit clears it.

BBIRQ—Bus Break Interrupt Detected

This bit is set when a bus breakpoint is hit. Writing a 1 to this bit clears it.

BRKIRQ—A-Line Vector Fetch Detected

This bit is set when a program breakpoint is hit. Writing a 1 to this bit clears it.

EMUEN—Emulation Enable

This bit is set to 1 in emulation mode.

15.3 TYPICAL DESIGN PROGRAMMING EXAMPLE

The following example is a typical emulator design, which is illustrated in Figure 15-2. It is a simple and low-cost design that uses the MC68EZ328 as the processor to be emulated. Other functional units include the host control to your PC or workstation via an RS-232 or dedicated parallel interface, an optional address comparator for extra breakpoint expansion, optional map FPGA for emulation memory remapping, a data bus MUX for hardware breakpoint insertion, and a MC68EZ328 pin-out extension to connect to the solder-on emulator pod. The entire MC68EZ328 bus should be buffered using level-shifting buffers when the emulator is designed in 5V and the processor is running at 3.3V.

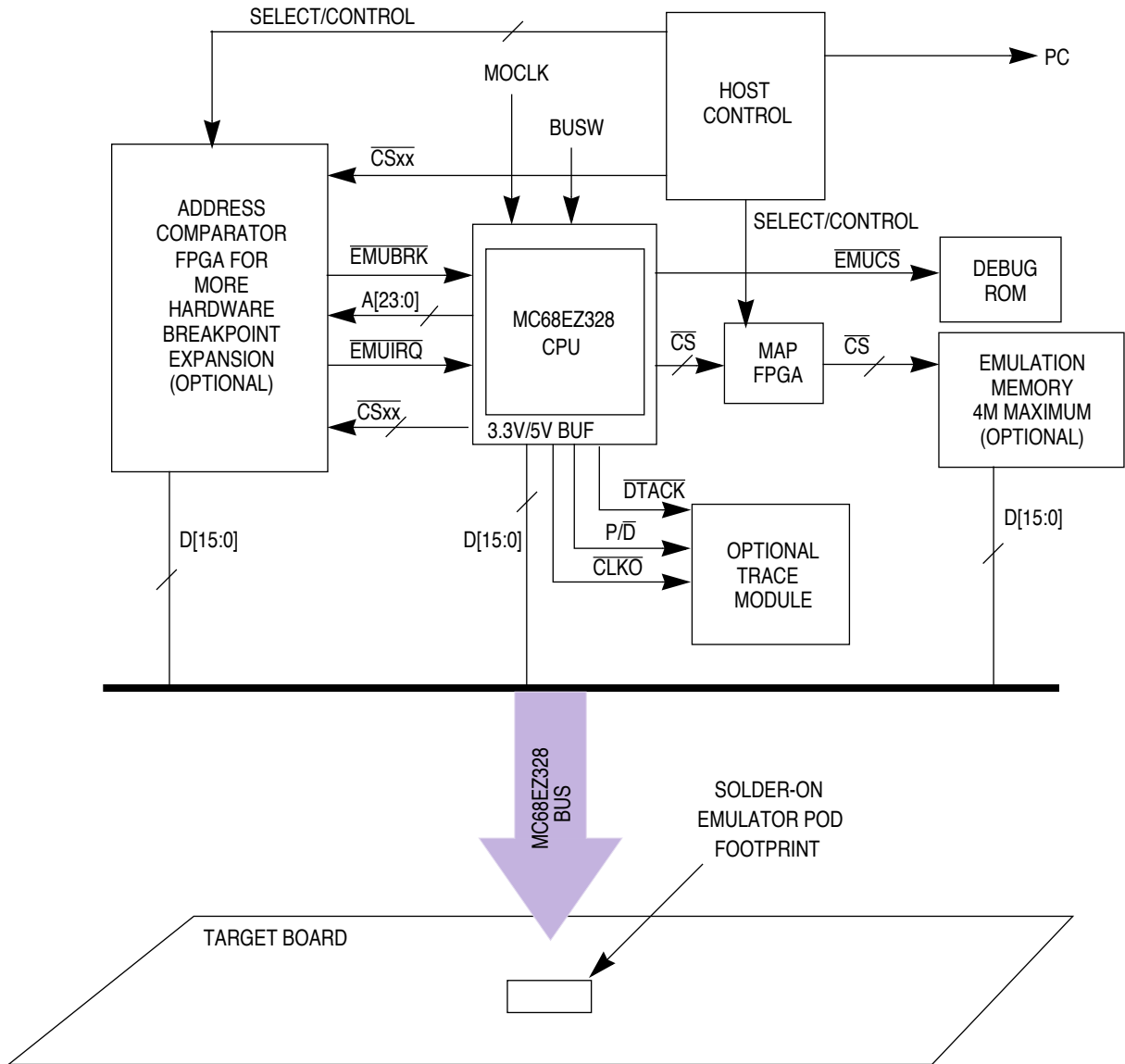

Figure 15-2. Typical Emulator Design Example

15.3.1 Host Interface

The host interface can be a processor-based or state machine-based circuit that is used to coordinate the activities between the emulation processor and the PC host. The interface can be an RS-232 or printer parallel I/O. Your interface runs on the PC and it will translate your requests to low-level commands and send them to the emulator's controller if there is one.

15.3.2 Dedicated Debug Monitor Memory

When a breakpoint is matched, the CPU must report its status and grab the necessary contents, such as internal registers, in the system. This information is then transmitted to the host control processor to be translated before it is passed to your interface on the PC. The emulation processor (the MC68EZ328 in Figure 15-2) completes these tasks with small routines that reside in the monitor space. The monitor is hard-mapped to 0xFFFFC0000-0xFFFFDFFFF, which is selected by the $\overline{\text{EMUCS}}$ signal.

15.3.3 Emulation Memory Mapping FPGA and Emulation Memory

Since the memory on the target board may not be fully built or debugged, you need to have some memory that replaces the target memory for debug at the initial stage. In some cases, ROM codes are downloaded to a shadowed RAM area for debugging purposes. The map FPGA will work with those chip-select signals to map them to the emulation memory, instead of going directly to the target board.

15.3.4 Optional Extra Hardware Breakpoint

You can add the FPGA address comparator to enhance the number of hardware breakpoints in the emulator. As discussed in [Section 15.1.4 Using the Interrupt Gate Module](#), in multi-breakpoint mode the external FPGA address comparator compares the lower address, the internal comparator compares the upper hidden address line, then a $\overline{\text{EMUIRQ}}$ signal is generated to tell the in-circuit emulation module to generate a breakpoint.

15.3.5 Optional Trace Module

You can also add a trace module to enhance the function of the emulator. Trace captures the bus signals of all of the cycles, so that when a stop is encountered, your interface software can report all the cycle traces back for that breakpoint. This action is based on the timebase of the CLK0 signal, $\overline{\text{P/D}}$ signal, and $\overline{\text{DTACK}}$ signal to decide whether it is a program or data fetch.

15.4 PLUG-IN EMULATOR DESIGN EXAMPLE

The following example is a plug-in emulator design, as shown in Figure 15-3. The design is simple and low-cost, which creates a very basic debugging environment.

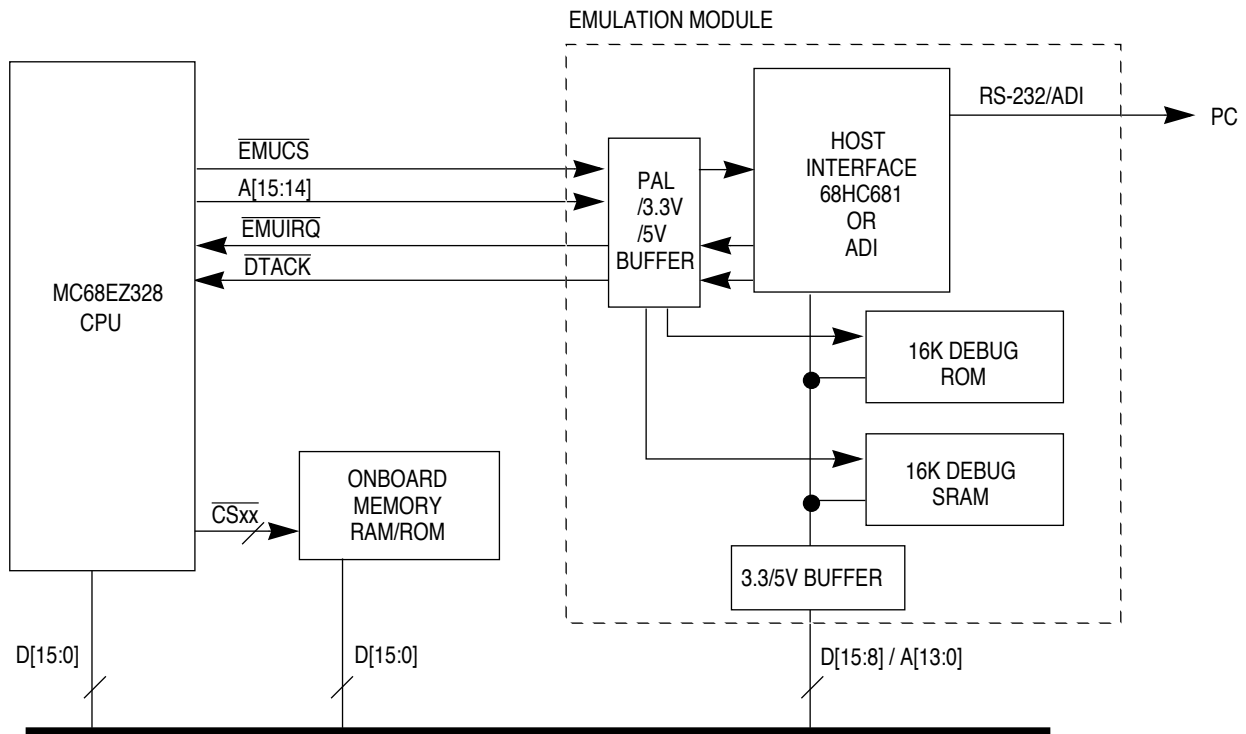

Figure 15-3. Plug-in Emulator Design Example

Although there is only one hardware breakpoint in this design, all other software breakpoints can be generated by replacing the memory content of the “A0” instruction. The \overline{EMUCS} is decoded by a PAL to generate chip-select signals to the UART (68HC681) or ADI interface and the debug RAM/ROM. The emulation module is buffered with 3.3/5V buffers so that it can communicate with the PC without causing any problems.

The entire emulation module only uses 29 pins, including a ground signal. This can be a built onto a very low-cost cable to ship with the software debugger package. These pins can remain on the production version of the system board for production testing, as well as diagnostic and failure analysis.

15.5 APPLICATION DEVELOPMENT DESIGN EXAMPLE

The following example is an application development system design, as shown in Figure 15-4. This example is for initial start-up designs and software development that occurs after the target hardware system is completed.

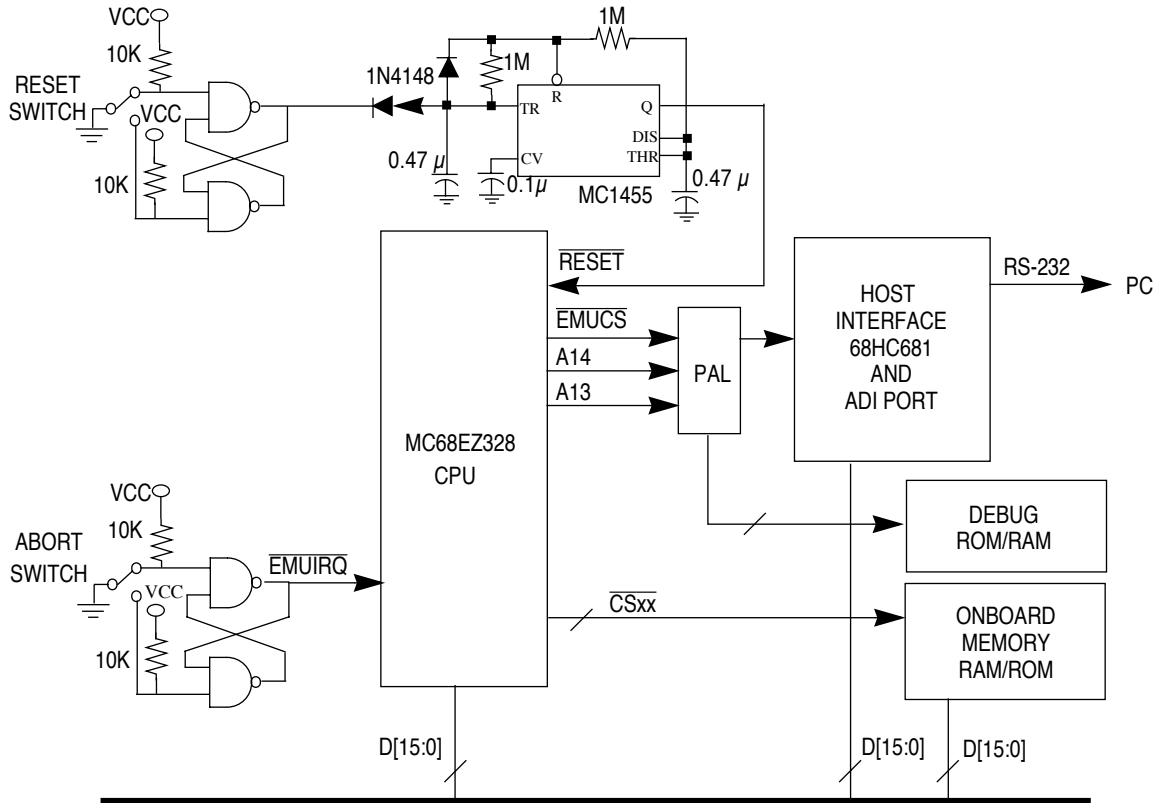

Figure 15-4. Application Development System Design Example

There is one reset switch and one abort switch. The abort switch is debounced and connected to the $\overline{\text{EMUIRQ}}$ signal. The $\overline{\text{RESET}}$ signal is generated by the MC1455 monostable timer. The host interface port is selected by the PAL decoding the $\overline{\text{EMUCS}}$, A13, and A14 signals. The board also provides optional SRAM/ROM plug-in sockets for expansion.

SECTION 16 BOOTSTRAP MODE

Bootstrap mode is designed to allow you to initialize a target system and download a program or data to the target system's RAM using the UART controller. Once it is downloaded, the program can be executed, which gives you a simple debugging environment for failure analysis and a channel to update programs stored in Flash memory. The features of bootstrap mode are as follows:

- Allows you to initialize your system and download programs and data to system memory using UART
- Accepts execution commands to run programs stored in system memory
- Provides an 8-byte long instruction buffer for 68000 instruction storage and execution

16.1 OPERATION

In bootstrap mode, the MC68EZ328's UART controller is initialized to 9600 baud, no parity, 8-bit character and 1 stop bit, and it is ready to download a program or data. To download the data or program, you must convert the code to a bootstrap format file, which is a text file that contains bootstrap records. A DOS-executable program "STOB.EXE" can be downloaded from our website to convert an S-record file to a bootstrap format file.

Before you can download a program to system memory, you should use the MC68EZ328's internal registers to initialize the target system. Since these internal registers can be treated as a type of memory, each of them can be initialized by issuing a bootstrap record.

The bootstrap design provides an 8-byte long instruction buffer to which you can download 68000 instructions. This feature enables you to run 68000 instructions even if the memory systems are disabled or in an MPU stand-alone system. The instruction buffer starts at 0xFFFFAA. Regardless of whether you are initializing internal registers, downloading a program to system RAM, or issuing a core instruction, bootstrap mode will only accept bootstrap record transfers that are made with the UART. The record type determines what will occur.

16.1.1 Entering Bootstrap Mode

Bootstrap mode is one of the three operation modes (normal, emulation, and bootstrap) of the MC68EZ328, except it has the highest priority. To enter bootstrap mode, you must drive the $\overline{\text{EMUBRK}}$ signal low and perform a system reset. After reset, bootstrap reset vectors are internally generated for reset vector fetch cycles. Figure 16-1 illustrates bootstrap mode reset vector fetch timing. These two-long-word reset vectors are loaded to the stack pointer

Bootstrap Mode

and program counter of the core. Then the built-in bootstrap program can run and accept data transfers.

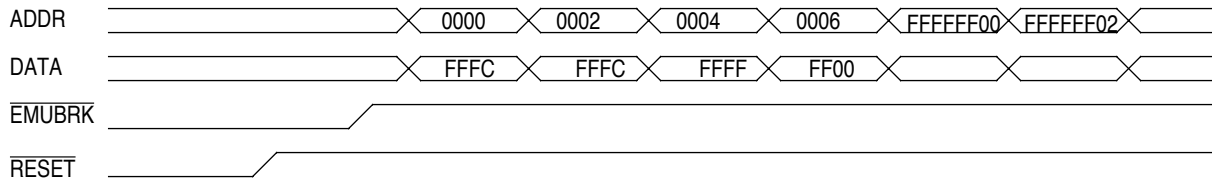

Figure 16-1. Bootstrap Mode Reset Timing



Note: In bootstrap mode, the reset vector (0x0–0x7) and A-line exception vector (0x28–0x2b) spaces are reserved for Motorola use only. Any memory read to these locations will return incorrect data.

16.1.2 Bootstrap Record Format

Bootstrap mode data transfers will only accept bootstrap records (b-records). Its format is shown in the table below. b-records are in uppercase and they end with a carriage return.

4-BYTE	1-BYTE	N(COUNT)-BYTE
ADDRESS	COUNT	DATA

There are two types of b-records that use the same format.

1. The data b-record contains data to be transferred. The 4-byte ADDRESS field indicates where the data will be stored and this address could be any MC68EZ328 internal register location. The COUNT field of the record contains the number of data bytes to be transferred. The DATA field contains the data to be transferred.
2. The execution b-record tells the bootloader to run a program starting at the location specified by the ADDRESS field of the b-record. The COUNT field for an execution b-record always contains 0x00 and no data in the DATA field.

An execution b-record is used in two situations:

- After you download a program to system RAM, issuing an execution b-record can initiate program execution. In this case, the ADDRESS field of the b-record will be the start address of the program.
- When you load a 68K instruction into the instruction buffer, issuing an execution b-record executes the 68K instruction that is stored in Ibuff and returns to

bootloader mode. In this case, the ADDRESS field of the b-record will be the start address of Ibuff.

16.1.3 Setting Up the RS-232 Terminal

To set up communication between your target system and the PC, set the communication specifications to 9600bps, no parity, 8-bit and 1 stop bit. You should pause after each line (b-record) is transferred to make sure each transferred ASCII character is echoed.

After setting up the hardware and system power-up and entering bootstrap mode, send any ASCII character to the target system to initiate the link. Once the bootloader receives this character, it adjusts the baud rate. If the link is successful, the bootloader will return a special character (@) as acknowledgment. The bootloader will return the same ASCII character that was transferred to the target system.

16.1.4 Changing the Speed of Communication

You can change the communication baud rate after 9600bps is set up in the RS-232 terminal. Simply issue a b-record to reinitialize the baud control register of the UART controller, which is described in [Section 11.3.2 UART Baud Control Register](#). For example, if the system uses a 32.768kHz external crystal, the baud control register is initialized to 0x0126 after 9600bps is set up, assuming that the system clock is divided by two (default). Changing the baud control register from 0x0126 to 0x0026 will switch the baud rate from 9600bps to 19200bps by issuing a b-record. After the last character of this b-record is sent (0), the echo of this last character will be in the new speed (19200bps). At this time, the host speed must immediately adjust to 19200bps.

The baud control register is a 2-byte register and bootstrap mode data transfers are byte-sized write cycles. Therefore, changing both bytes of the baud control register requires two steps and each byte change must still at the standard communication speed for the host to set up new communication. For example, to change the speed from 9600bps to 57600bps, follow these steps:

1. Issue the b-record "FFFFFF9020100" to change the baud control register from 0x0126 to 0x0026 and the new speed will change to 19200bps. Then reset the host speed to 19200bps to synchronize with the target system.
2. Issue another b-record to change the baud control register from 0x0026 to 0x0038 of the final 57600bps speed and readjust the host speed to 57600bps.

16.2 SYSTEM INITIALIZATION PROGRAMMING EXAMPLE

Before you can download a program to system memory, the target system may need to be initialized using the internal registers. An init file can be built using a text editor. The example below is an init file for the MC68EZ328ADS board.

```
*****
* init.b -- Init ADS to default monitor config
* date: 04/20/98
*
*****
```

Bootstrap Mode

```

FFFFF1180130  emucs  init
FFFFF000011C  SCR  init
FFFFFB0A0100  Disable WD
FFFFF42B0183  enable clko
FFFFF40B0100  enable chip select
FFFFFD0D0108  disable hardmap
FFFFFD0E0107  clear level 7 interrupt
FFFFF100020100 CSA 2M - 4M
FFFFF1100201A7
FFFFF102020000 CSB 0 - 256K
FFFFF112020091
FFFFFC00028F00 DRAM Config
FFFFFC02029667 DRAM Control
FFFFF106020200 CSD init -- RAS0 4M-6M, RAS1 6M-8M
FFFFF11602029D enable DRAM cs
FFFFF3000140   IVR
FFFFF30404007FFFF IMR
    
```



Note: The bootloader starts receiving a new b-record when a nonhexadecimal digit is received. Therefore, comments can be made in the b-record file as long as it contains no more than eight consecutive hexadecimal digits.

16.3 APPLICATION PROGRAMMING EXAMPLE

The following example can be used to calculate a crc value. The example demonstrates how assembly code is assembled and downloaded to system RAM.

```

section code
START:
copy  clr.l  d1 d1 is used to count the number of words copied.
clr.w  d2          ;d2 is used to count the number of words copied.
nextwd move.w  (a0,d2),d6
move.w  d6,(a1)+
add.l   #2,d1          ;Count the number of words copied.
add.w   #2,d2          ;Count the number of words copied.
cmpi.w  #16,d2
blt     nextwd        ;until the whole section has been copied.
clr.w   d2
cmp.l   d0,d1          ;Copy the next word (nextwd)
blt     nextwd        ;until the whole section has been copied.

crc     clr.l  D0
lp2     add.l  (A0)+,D0
cmp.l   A0,A1
bpl.b  lp2
nop
rts
    
```

After you have assembled and linked the program above, generate the following s-record file.

```
S0030000FC
S1134000428142423C30200032C6548154420C4228
S113401000106DF04242B2806DEA4280D098B3C87D
S10940206AFA4E714E75B0
S9030000FC
```

Run the DOS program, STOB.EXE, to convert the above s-records to bootstrap format.

```
0000400010428142423C30200032C6548154420C42
000040101000106DF04242B2806DEA4280D098B3C8
00004020066AFA4E714E75
```

You can now download the above b-record file to the target system using the UART port in bootstrap mode. Since this b-record file will be loaded to system RAM, initialize the system by downloading an init b-record file.

To run the above program after it is downloaded to RAM, you can issue an execution b-record "00040000", where "0004000" is the start address of the program and the last two zeros indicate that this is an execution b-record and not a data record.

To resume bootstrap mode operation after running a program, the last instruction in the application program will be "jmp \$FFFFFF44". This is to start receiving a new b-record.

You can enter any b-record in a RS-232 terminal environment, but when you press a key, the key is sent to the bootloader to be assembled. Although the backspace capability is not implemented, you can terminate the b-record any time by pressing the ENTER key. As long as no program execution b-record is issued, the MC68EZ328 will stay in bootstrap mode.

16.4 INSTRUCTION BUFFER USAGE EXAMPLE

The following example demonstrates how to run a 68K instruction using the instruction buffer.

```
ORG.L $FFFFFFAA; instruction buffer location
move.w#$55,D0; 4-byte long instruction(303C0055)
nop; fill the rest of IBUFF
nop
end
```

After assembling and converting the data to b-record format, it becomes:

```
FFFFFFAA08303C00554E714E71
FFFFFFAA00
```

(where FFFFFFFAA is IBUFF address location)

The first b-record loads the instruction buffer. The second b-record tells the boot loader to run the instruction in the instruction buffer. When execution is complete, it accepts new

b-record transfers. The CPU register D0-D6 and A0 are used by the bootloader program. Writing to these registers may corrupt the bootloader program.

16.5 BOOTLOADER FLOWCHART

The following flowchart illustrates how the the bootloader program operates inside MC68EZ328. The bootloader starts when the MC68EZ328 enters bootstrap mode:

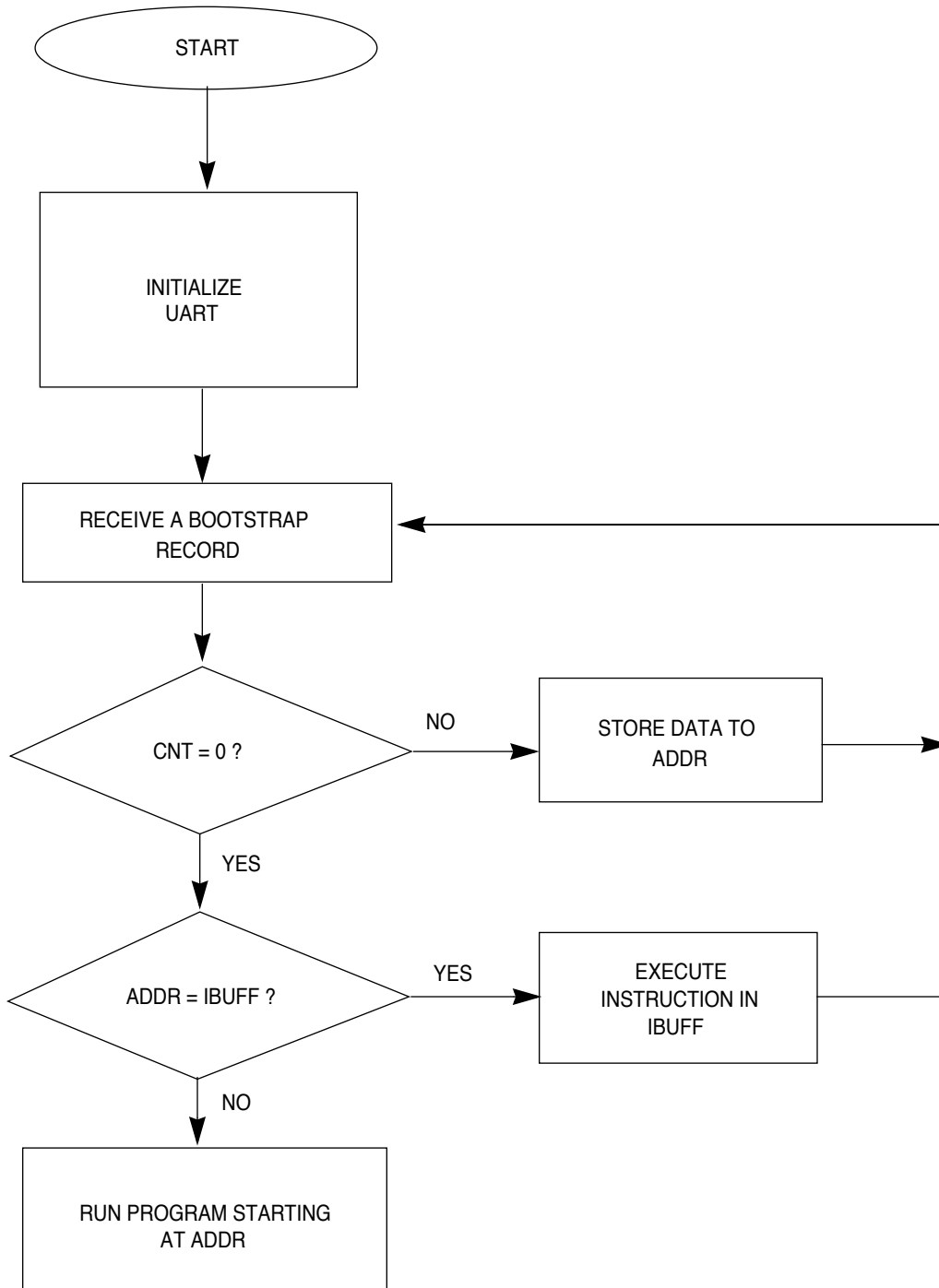

Figure 16-2. Bootloader Program Operation

16.6 SPECIAL NOTES

The following items may be useful when you are in bootstrap mode.

- In bootstrap mode, reset vector (0x0–0x7) and A-line exception vector (0x28–0x2b) space are dedicated to bootstrap operation. Any memory read to these locations will give incorrect data, so you should not use them.
- A b-record is a string of uppercase hex characters with optional comments that follow.
- Comments in a b-record or b-record file must not contain any word or symbol that is longer than nine characters, while the following characters can be used in a string of any length: space, !, “, #, \$, %, &, (,), *, +, -, ., /, ,, (all of these have an ASCII code value that is less than 0x30).
- The bootloader program echos all characters being received, but only those having an ASCII code value greater than or equal to 0x30 are kept for b-record assembling. Sending a character that is not a b-record (ASCII < 0x30) will force the bootloader to start a new b-record.
- D[6:0] and A0 are used by the bootloader program. Writing to these registers may corrupt the bootloader program.

Please visit our website for bootstrap utility programs.



SECTION 17

APPLICATION GUIDE

This section contains information that will help you integrate the MC68EZ328 into your design. It includes a design checklist and instructions for using the MC68EZ328 Application Development System (ADS) board to get started with your design.

17.1 DESIGN CHECKLIST

When integrating the MC68EZ328 microprocessor into an application, the following items can help guide you through the process. These guidelines originated from common problems that were found while debugging and operating actual implementations.

- **Find the Mask Number and Version of Your Chip**
Each chip has different sets of numbers etched onto it and one of these sets is the mask and revision number for that particular chip. The mask number and the revision number are combined into one. For example, 0F98S. 0 is the revision number and F98S is the mask number. You need this information in order to find the errata for that version of the chip. Obtaining the appropriate errata will help you design your product more efficiently. Once you know your mask and revision numbers, go to our website and look for your particular MC68EZ328 chip errata. If you do not have web access, contact your local Motorola sales office.
- **Using the MC68EZ328 in a System With an 8-Bit Data Bus**
To give you more flexibility, MC68EZ328 supports both 8- and 16-bit data bus modes. You use the $\overline{\text{RESET}}$ and $\overline{\text{BUSW/DTACK/PG0}}$ signals to select either 8- or 16-bit mode. The default data bus width for the $\overline{\text{CSA0}}$ and $\overline{\text{CSA1}}$ signals is controlled by the $\overline{\text{BUSW}}$ signal. $\overline{\text{CSA0}}$ is normally connected to boot ROM. For a system with 16-bit data boot ROM, $\overline{\text{BUSW}}$ is pulled high or left unconnected during system reset. For an 8-bit data boot ROM system, $\overline{\text{BUSW}}$ must be externally driven low during system reset. The $\overline{\text{BUSW}}$ status is latched by the rising edge of the $\overline{\text{RESET}}$ signal and the latched $\overline{\text{BUSW}}$ status is indicated by the $\overline{\text{BUSW}}$ bit of the chip-select A control register. After reset, this pin can be used as a $\overline{\text{DTACK}}$ or $\overline{\text{PG0}}$ function.

After reset, $\overline{\text{BUSW/DTACK/PG0}}$ uses the $\overline{\text{DTACK}}$ function. You should permanently drive this signal low for an 8-bit system to force all bus cycles to a zero wait-state until this pin is reconfigured to the $\overline{\text{PG0}}$ function. Fortunately, the system clock is divided by two (the $\overline{\text{PRESC}}$ bit in the $\overline{\text{PLLCR}}$ register is set) after reset, which doubles the length of each bus cycle and provides ample access time to memories. Therefore, you should program the $\overline{\text{BUSW/DTACK/PG0}}$ to the $\overline{\text{PG0}}$ function before you configure the system clock to divide by one (the $\overline{\text{PRESC}}$ bit in the $\overline{\text{PLLCR}}$ register is cleared).

Clock and Layout Considerations

- **Place the Crystal Within 0.5 Inches of the MC68EZ328**
The crystal and the capacitors must be as close to the chip as possible.
- **If You are Using an RC Reset Circuit, Place the Resistor and Capacitor Within 0.5 Inches of the MC68EZ328**
The $\overline{\text{RESET}}$ pin is a schmitt trigger input signal. A simple power-up RC reset circuit can be used. Since the external crystal takes time to stabilize, a 200-400msec power-up reset pulse is recommended.
- **Use Multiple Power and Ground Planes**
You should use at least one ground plane, one 3.3V VCC plane, and one 5V VCC plane (if 5V parts exist in the system). This ensures easy routing to and from the MC68EZ328.

Bus and I/O Considerations

- **Do Not Leave Unused Input Pins Floating**
Unused inputs should be tied high or low, but not left floating. You can tie unused inputs directly to VCC or GND or through pull-ups or pull-downs to VCC or GND.
- **Use the Port Pins Efficiently**
When you are not using the port pins, configure them as an input with pull-up enabled or an output with pull-up disabled.
- **Apply Internal Pull-Up to Dedicated Function Pins**
Many pins are mixed with a dedicated function. The internal pull-up or pull-down resistors apply to both the dedicated function and the general I/O function. For instance, when you are using the RXD/PE4 signal and the RXD function, the associated internal pull-up resistor can be used to pull up the RXD input signal.
- **Do Not Rely Solely on the Internal Pull-Up Resistors**
The internal resistors are normally 100K Ohms, but their deviation is large.
- **Always Provide a Development Interface Port on Your Design**
The MC68EZ328 has bootstrap mode and a bootstrap utility program that you can use to download program/data to your target system. You can also perform some simple hardware debugging functions. However, bootstrap mode only uses the RXD and TXD signals of the UART port, so it is recommended that you include a UART port in your design for system debugging and flash memory updating.

17.2 USING THE MC68EZ328ADS BOARD

To begin development, follow these general guidelines:

1. Obtain the M68EZ328ADS board from your local Motorola sales office using part number M68EZ328ADS.
2. Use the Microtek SLD Debug Monitor, which comes with the board, to start developing your design. The SDS Debug Monitor is another recommended debugger and compiler.
3. Connect the MC68EZ328ADS board to the host computer.

SECTION 18 ELECTRICAL CHARACTERISTICS

This section contains the necessary electrical characteristics for the MC68EZ328 microprocessor.

18.1 MAXIMUM RATINGS

RATING	SYMBOL	VALUE	UNIT
Supply Voltage	V _{CC}	-0.3 to 7.0	V
Input Voltage	V _{IN}	-0.3 to 7.0	V
Maximum Operating Temperature Range	T _A	T _L to T _H 0 to 70	°C
Storage Temperature	T _{stg}	-55 to 150	°C

18.2 DC ELECTRICAL CHARACTERISTICS

NUM	CHARACTERISTIC	3.3V		UNIT
		MINIMUM	MAXIMUM	
1	Operating Current at 16MHz	—	20	mA
2	Standby Current	—	20	µA
V _{IH}	Input High Voltage	2.0	—	V
V _{IL}	Input Low Voltage	—	0.8	V
V _{OH}	Output High Voltage (I _{OH} = 2.0mA)	2.4	—	V
V _{OL}	Output Low Voltage (I _{OL} = -2.5mA)	—	0.4	V
I _{IL}	Input Low Leakage Current (V _{IN} = GND, no pull-up or pull-down)	—	±1	µA
I _{IH}	Input High Leakage Current (V _{IN} = V _{DD} , no pull-up or pull-down)	—	±1	µA
I _{OH}	Output High Current (V _{OH} = 0.8V _{DD} , V _{DD} = 2.9V)	2		mA
I _{OL}	Output Low Current (V _{OL} = 0.4V, V _{DD} = 2.9V)		2	mA
I _{OZ}	Output Leakage Current (V _{out} = V _{DD} , output is three-stated)	—	±5	µA

NOTE: Standby current is measured only when the real-time clock is running.

18.3 AC ELECTRICAL CHARACTERISTICS

The AC characteristics consist of output delays, input setup and hold times, and signal skew times. All signals are specified relative to an appropriate edge of other signals. All timing specifications are specified at an operating frequency from 0 to 16MHz with an operating supply voltage from $V_{DD, min}$ to $V_{DD, max}$ under an operating temperature from T_L to T_H . All timing are measured at 95pF loading.

18.3.1 CLKO reference to Chip-Select Signals Timing

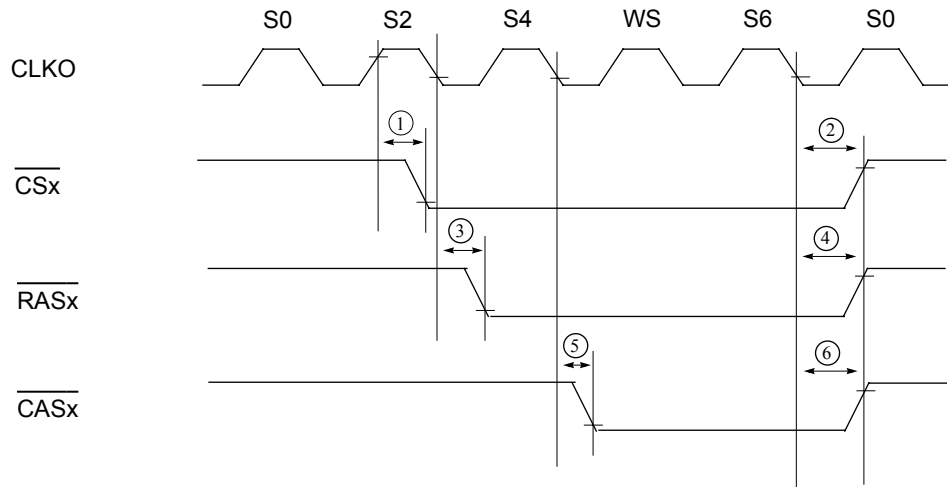

NUM	CHARACTERISTIC	3.3V		UNIT
		MINIMUM	MAXIMUM	
1	CLKO high to \overline{CSx} Asserted	—	30	ns
2	CLKO low to \overline{CSx} Negated	—	30	ns
3	CLKO low to \overline{RASx} Asserted	—	30	ns
4	CLKO low to \overline{RASx} Negated	—	30	ns
5	CLKO low to \overline{CASx} Asserted	—	15	ns
6	CLKO low to \overline{CASx} Negated	—	30	ns

NOTE: WS is the number of wait-states in the current memory access cycle.
T is the system clock period.

18.3.2 Chip-Select Read Cycle Timing

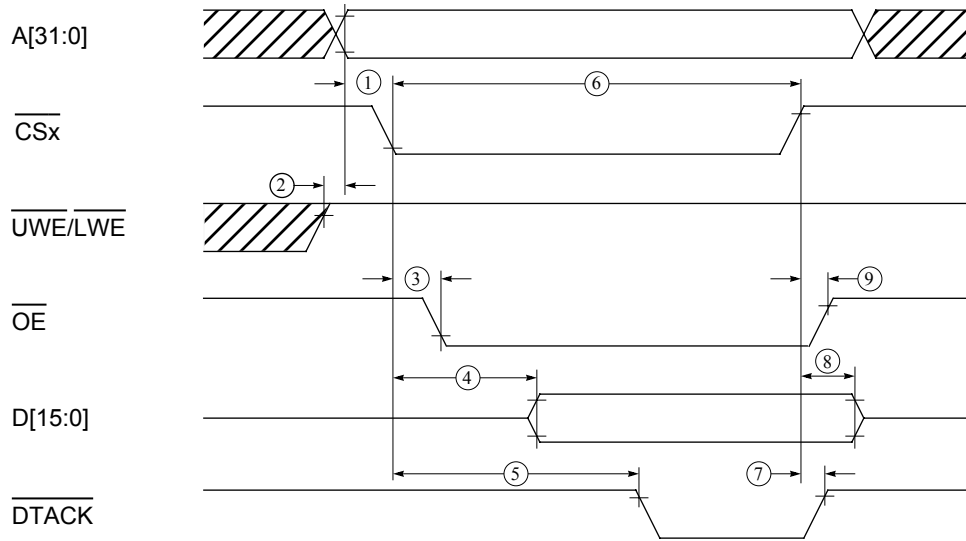

NUM	CHARACTERISTIC	3.3V		UNIT
		MINIMUM	MAXIMUM	
1	Address Valid to \overline{CSx} Asserted	60	—	ns
2	\overline{DWE} Negated before Row Address Valid	0	—	ns
3	\overline{CSx} Asserted to \overline{OE} Asserted	—	0	ns
4	Data-In Valid from \overline{CSx} Asserted	—	$100 + nT$	ns
5	External \overline{DTACK} Input Setup from \overline{CSx} Asserted	$30 + nT$	—	ns
6	\overline{CSx} Pulse Width	$130 + nT$	—	ns
7	External \overline{DTACK} Input Hold after \overline{CSx} is Negated	0	—	ns
8	Data-In Hold after \overline{CSx} is Negated	0	—	ns
9	\overline{OE} Negated after \overline{CSx} is Negated	8	21	ns

NOTE: n is the number of wait-states in the current memory access cycle.

T is the system clock period.

The external \overline{DTACK} input requirement is eliminated when \overline{CSx} is programmed to use internal \overline{DTACK} . \overline{CSx} stands for $\overline{CSA0}$, $\overline{CSA1}$, $\overline{CSB0}$, $\overline{CSB1}$, $\overline{CSC0}$, $\overline{CSC1}$, $\overline{CSD0}$, or $\overline{CSD1}$.

18.3.3 Chip-Select Write Cycle Timing

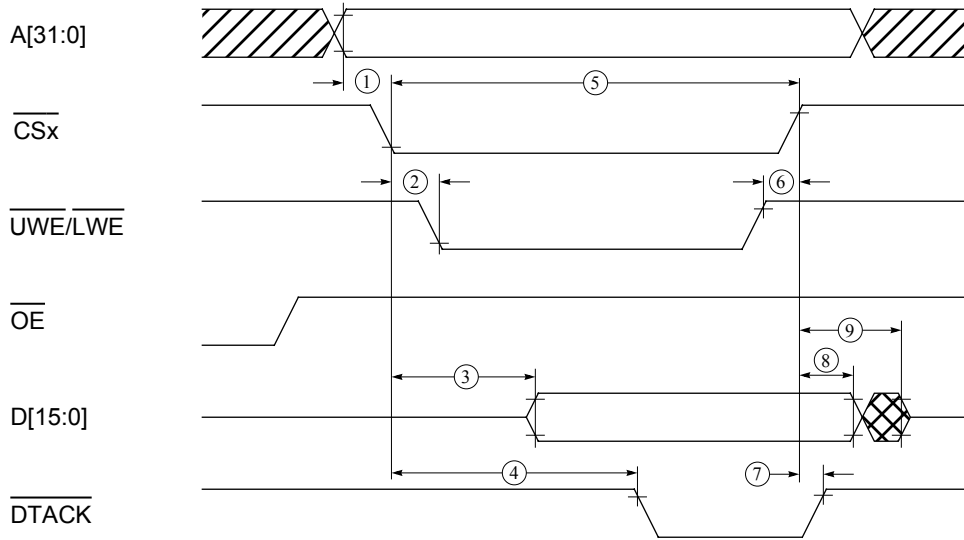

NUM	CHARACTERISTIC	3.3V		UNIT
		MINIMUM	MAXIMUM	
1	Address Valid to \overline{CSx} Asserted	60	—	ns
2	\overline{CSx} Asserted to $\overline{UWE/LWE}$ Asserted	0	8	ns
3	\overline{CSx} Asserted to Data-Out Valid	—	40	ns
4	External \overline{DTACK} Input Setup from \overline{CSx} Asserted	$30 + nT$	—	ns
5	\overline{CSx} Pulse Width	$130 + nT$	—	ns
6	$\overline{UWE/LWE}$ Negated before \overline{CSx} is Negated	30	35	ns
7	External \overline{DTACK} Input Hold after \overline{CSx} is Negated	0	—	ns
8	Data-Out Hold after \overline{CSx} is Negated	30	—	ns
9	\overline{CSx} Negated to Data-Out in Hi-Z	—	48	ns

NOTE : n is the number of wait-states in the current memory access cycle.

T is the system clock period.

The external \overline{DTACK} input requirement is eliminated when \overline{CSx} is programmed to use the internal \overline{DTACK} . \overline{CSx} stands for CSA0, CSA1, CSB0, CSB1, CSC0, CSC1, CSD0, or CSD1.

18.3.4 Chip-Select Flash Write Cycle Timing

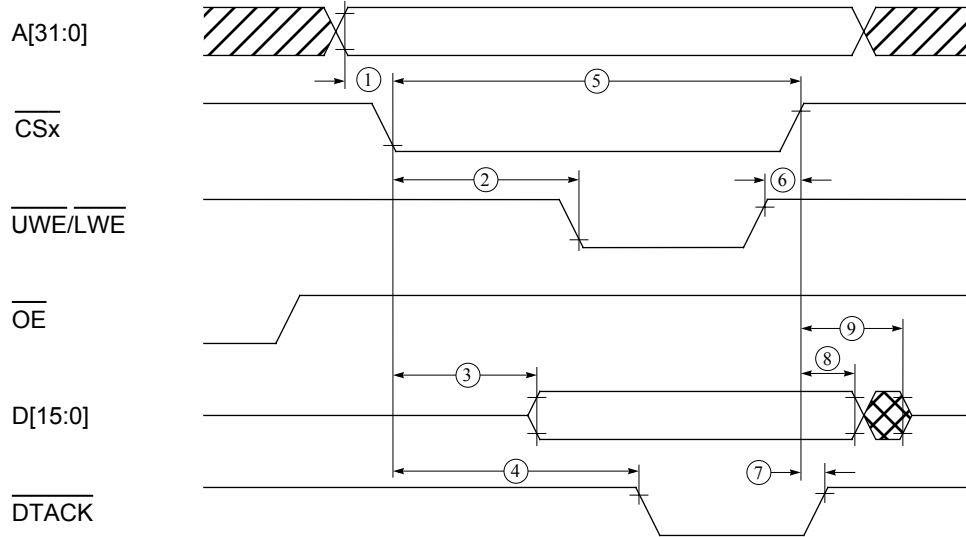

NUM	CHARACTERISTIC	3.3V		UNIT
		MINIMUM	MAXIMUM	
1	Address Valid to \overline{CSx} Asserted	60	—	ns
2	\overline{CSx} Asserted to $\overline{UWE/LWE}$ Asserted	54	60	ns
3	\overline{CSx} Asserted to Data-Out Valid	—	40	ns
4	External \overline{DTACK} Input Setup from \overline{CSx} Asserted	$30 + nT$	—	ns
5	\overline{CSx} Pulse Width	$130 + nT$	—	ns
6	$\overline{UWE/LWE}$ Negated before \overline{CSx} is Negated	30	35	ns
7	External \overline{DTACK} Input Hold after \overline{CSx} is Negated	0	—	ns
8	Data-Out Hold after \overline{CSx} is Negated	30	—	ns
9	\overline{CSx} Negated to Data-Out in Hi-Z	—	48	ns

NOTE: n is the number of wait-states in the current memory access cycle.
 T is the system clock period.

The external \overline{DTACK} input requirement is eliminated when \overline{CSx} is programmed to use the internal \overline{DTACK} . \overline{CSx} stands for CSA0, CSA1, CSB0, CSB1, CSC0, CSC1, CSD0, or CSD1.

18.3.5 DRAM Read Cycle 16-Bit Access (CPU Bus Master)

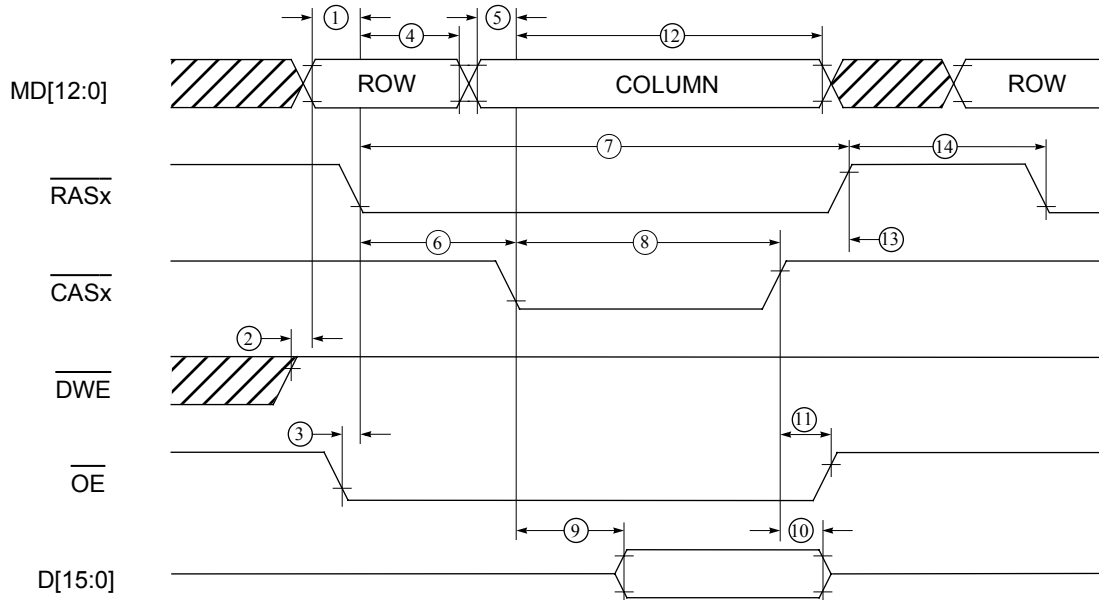

NUM	CHARACTERISTIC	3.3V		UNIT
		MINIMUM	MAXIMUM	
1	Row Address Valid to $\overline{\text{RASx}}$ Asserted	65	—	ns
2	$\overline{\text{DWE}}$ Negated before Row Address Valid	0	—	ns
3	$\overline{\text{OE}}$ Asserted before $\overline{\text{RASx}}$ is Asserted	0	—	ns
4	$\overline{\text{RASx}}$ Asserted before Row Address Invalid	25	—	ns
5	Column Address Valid to $\overline{\text{CASx}}$ Asserted	15	—	ns
6	$\overline{\text{RASx}}$ Asserted to $\overline{\text{CASx}}$ Asserted	60	62	ns
7	$\overline{\text{RASx}}$ Pulse Width	$116 + nT$	—	ns
8	$\overline{\text{CASx}}$ Pulse Width	$60 + nT$	—	ns
9	$\overline{\text{CASx}}$ Asserted to Data-In Valid	—	$15 + nT$	ns
10	Data-In Hold after $\overline{\text{CASx}}$ is Negated	0	—	ns
11	$\overline{\text{OE}}$ Negated after $\overline{\text{CASx}}$ is Negated	0	2	ns
12	$\overline{\text{CASx}}$ Asserted before Column Address Invalid	100	—	ns
13	$\overline{\text{RASx}}$ Negated after $\overline{\text{CASx}}$ is Negated	0	—	ns
14	$\overline{\text{RASx}}$ Precharge Time	120	—	ns

NOTE: n is the number of wait-states in the current memory access cycle.
 T is the system clock period.
 RASx stands for RAS0 and RAS1. CASx stands for CAS0 and CAS1.

18.3.6 DRAM Write Cycle 16-Bit Access (CPU Bus Master)

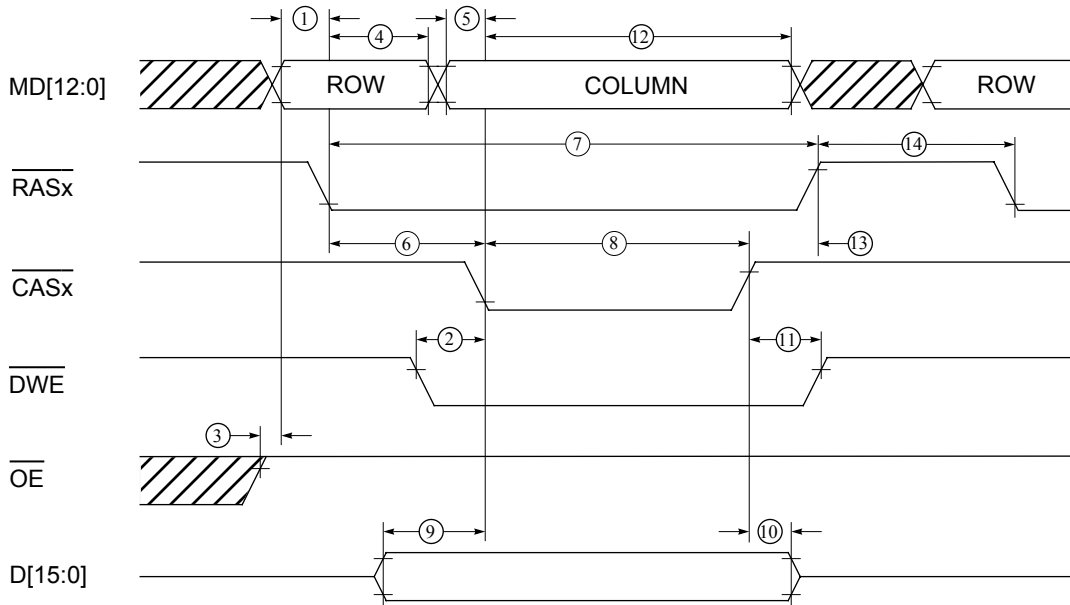

NUM	CHARACTERISTIC	3.3V		UNIT
		MINIMUM	MAXIMUM	
1	Row Address Valid to $\overline{\text{RASx}}$ Asserted	65	—	ns
2	$\overline{\text{DWE}}$ Asserted before $\overline{\text{CASx}}$ Asserted	25	—	ns
3	$\overline{\text{OE}}$ Asserted before $\overline{\text{RASx}}$ Asserted	0	—	ns
4	$\overline{\text{RASx}}$ Asserted before Row Address Invalid	25	—	ns
5	Column Address Valid to $\overline{\text{CASx}}$ Asserted	15	—	ns
6	$\overline{\text{RASx}}$ Asserted to $\overline{\text{CASx}}$ Asserted	60	62	ns
7	$\overline{\text{RASx}}$ Pulse Width	$116 + nT$	—	ns
8	$\overline{\text{CASx}}$ Pulse Width	$60 + nT$	—	ns
9	Data-Out Valid before $\overline{\text{CASx}}$ Asserted	30	—	ns
10	Data-Out Hold after $\overline{\text{CASx}}$ Negated	25	—	ns
11	$\overline{\text{DWE}}$ Negated after $\overline{\text{CASx}}$ Negated	15	—	ns
12	$\overline{\text{CASx}}$ Asserted before Column Address Invalid	100	—	ns
13	$\overline{\text{RASx}}$ Negated after $\overline{\text{CASx}}$ Negated	0	—	ns
14	$\overline{\text{RASx}}$ Precharge Time	120	—	ns

NOTE: n is the number of wait-states in the current memory access cycle.
 T is the system clock period.
 RASx stands for RAS0 and RAS1. CASx stands for CAS0 and CAS1.

18.3.7 DRAM Hidden Refresh Cycle (Normal Mode)

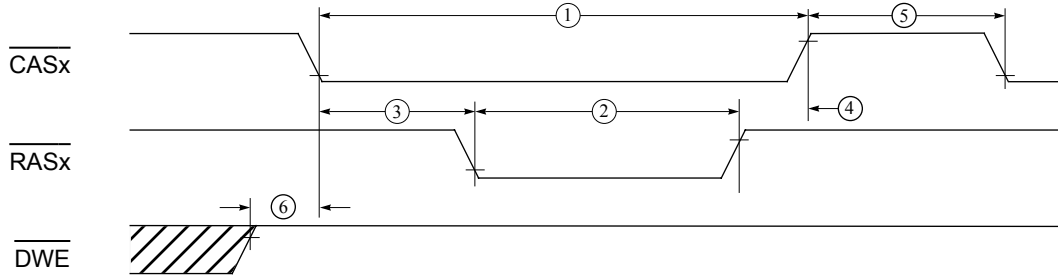

NUM	CHARACTERISTIC	3.3V		UNIT
		MINIMUM	MAXIMUM	
1	RASx Pulse Width	180	—	ns
2	CASx Pulse Width	120	—	ns
3	CASx Asserted to RASx Asserted	58	62	ns
4	RASx Negated to CASx Negated	0	—	ns
5	CASx Negated to next CASx Asserted	120	—	ns
6	DWE Negated before CASx Asserted	60	—	ns

NOTE: RASx stands for RAS0 and RAS1. CASx stands for CAS0 and CAS1.

18.3.8 DRAM Hidden Refresh Cycle (Low Power Mode)

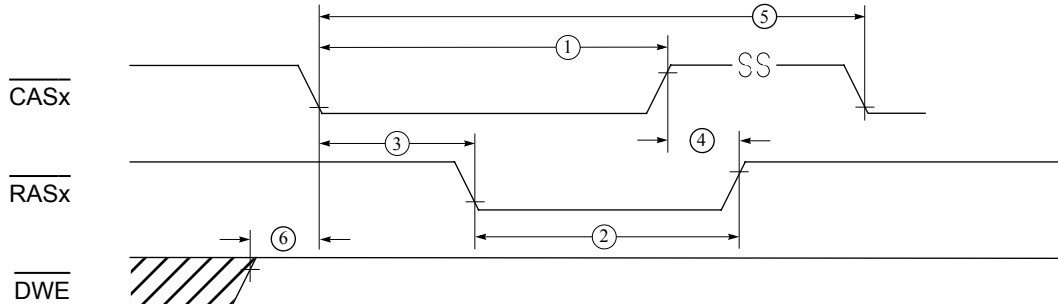

NUM	CHARACTERISTIC	3.3V		UNIT
		MINIMUM	MAXIMUM	
1	RASx Pulse Width	300	—	ns
2	CASx Pulse Width	300	—	ns
3	CASx Asserted to RASx Asserted	60	80	ns
4	RASx Negated to CASx Negated	60	80	ns
5	Refresh Cycle (using 32.768KHz crystal)	15.26	—	us
5	Refresh Cycle (using 38.400KHz crystal)	13.02	—	us
6	DWE Negated before CASx Asserted	60	—	ns

NOTE: RASx stands for RAS0 and RAS1. CASx stands for CAS0 and CAS1.

18.3.9 LCD SRAM/ROM DMA Cycle 16-Bit Mode Access(1 ws) (

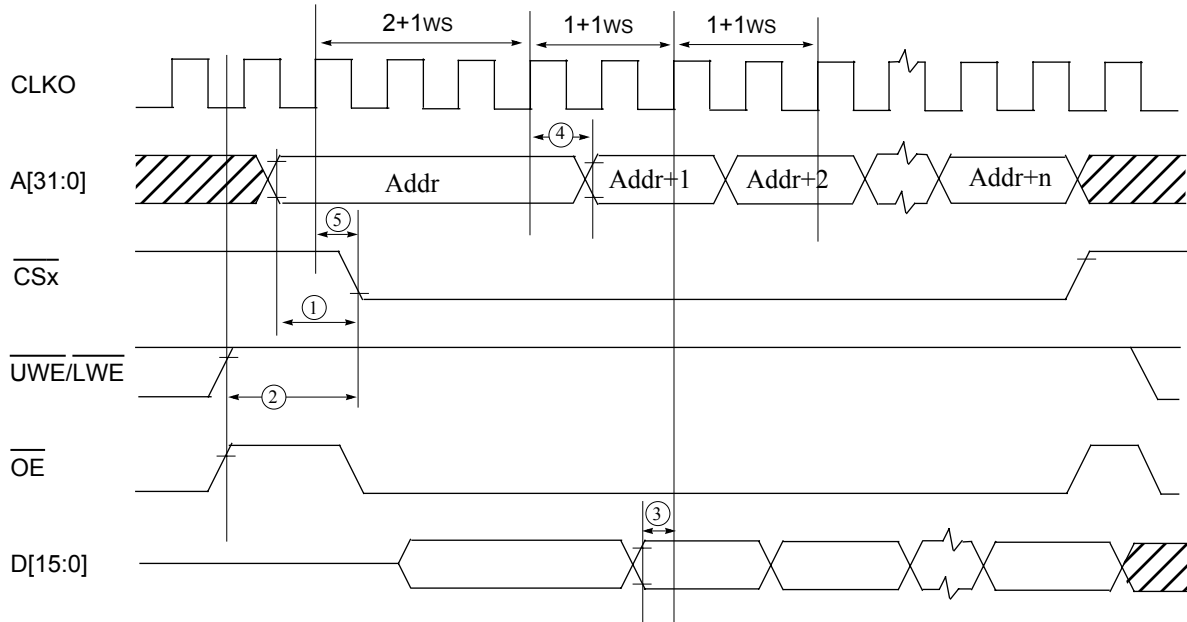

NUM	CHARACTERISTIC	3.3V		UNIT
		MINIMUM	MAXIMUM	
1	Address Valid to $\overline{\text{CSx}}$ Asserted	20	—	ns
2	$\overline{\text{UWE/LWE}}$ to $\overline{\text{CSx}}$ Asserted	20	—	ns
3	Data setup time	5	—	ns
4	CLKO to address valid	—	30	ns
5	CLKO high to $\overline{\text{CSx}}$	—	20	ns

NOTE: WS is the number of wait-states in the current memory access cycle.

18.3.10 LCD DRAM DMA Cycle 16-Bit EDO Mode Access (LCD Bus Master)

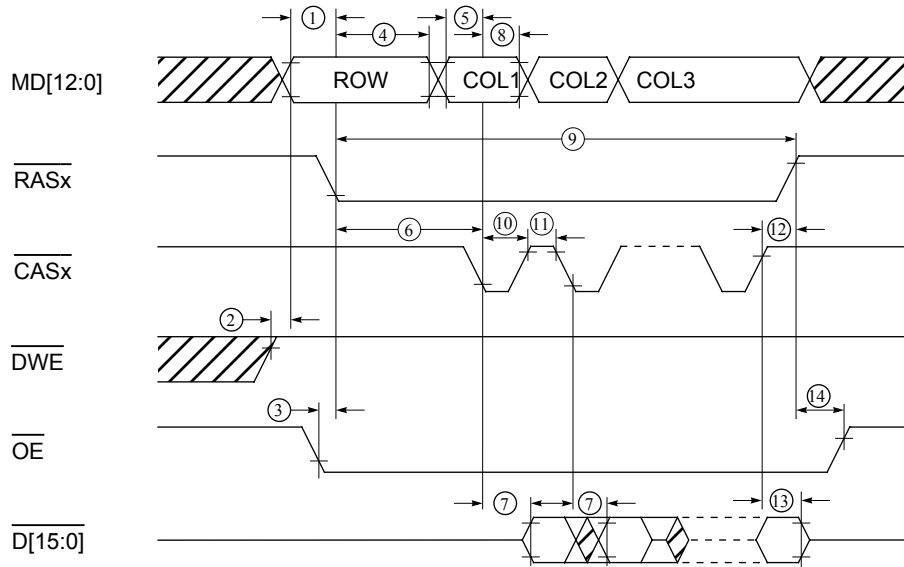

NUM	CHARACTERISTIC	3.3V		UNIT
		MINIMUM	MAXIMUM	
1	Row Address Valid to $\overline{\text{RASx}}$ Asserted	80	—	ns
2	$\overline{\text{DWE}}$ Negated before Row Address Valid	0	—	ns
3	$\overline{\text{OE}}$ Asserted before $\overline{\text{RASx}}$ Asserted	0	—	ns
4	$\overline{\text{RASx}}$ Asserted before Row Address Invalid	24	—	ns
5	Column Address Valid to $\overline{\text{CASx}}$ Asserted	15	—	ns
6	$\overline{\text{RASx}}$ Asserted to $\overline{\text{CASx}}$ Asserted	60	—	ns
7	$\overline{\text{CASx}}$ Asserted to Data-In Valid	—	15	ns
8	$\overline{\text{CASx}}$ Asserted before Column Address Invalid	30	—	ns
9	$\overline{\text{RASx}}$ Pulse Width	2T	—	ns
10	$\overline{\text{CASx}}$ Pulse Width	25	—	ns
11	$\overline{\text{CASx}}$ Precharge Time	30	—	ns
12	$\overline{\text{RASx}}$ Negated to $\overline{\text{CASx}}$ Negated	6	—	ns
13	Data-In Hold after $\overline{\text{CASx}}$ Negated	0	—	ns
14	$\overline{\text{OE}}$ Negated after $\overline{\text{CASx}}$ Negated	0	2	ns

NOTE: T is the system clock period.
 RASx stands for RAS0 and RAS1.
 CASx stands for CAS0 and CAS1.

18.3.11 LCD DRAM DMA Cycle 16-Bit Page Mode Access (LCD Bus Master)

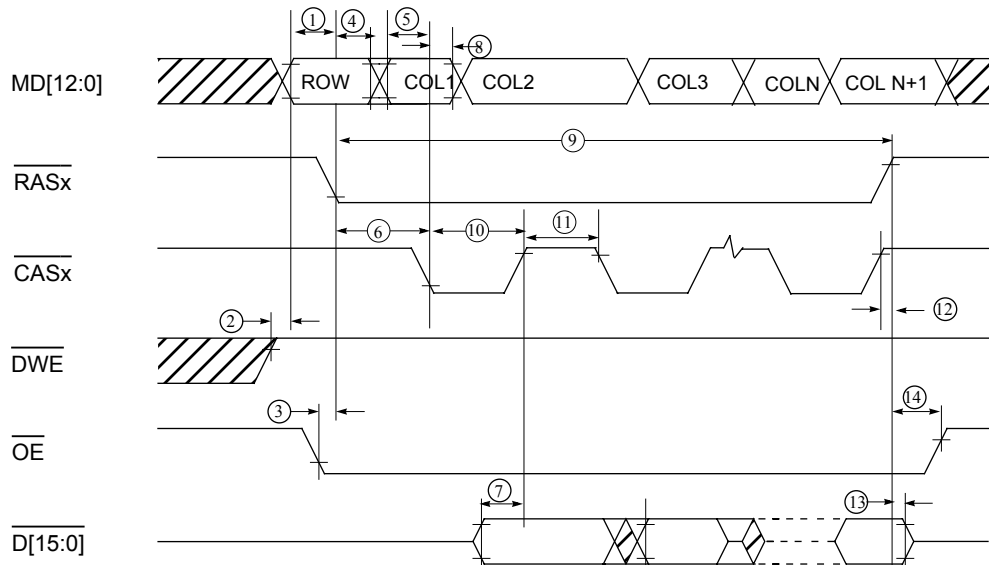

NUM	CHARACTERISTIC	3.3V		UNIT
		MINIMUM	MAXIMUM	
1	Row Address Valid to RASx Asserted	80	—	ns
2	DWE Negated before Row Address Valid	0	—	ns
3	OE Asserted before RASx Asserted	0	—	ns
4	RASx Asserted before Row Address Invalid	24	—	ns
5	Column Address Valid to CASx Asserted	15	—	ns
6	RASx Asserted to CASx Asserted	60	—	ns
7	Data setup time	20	—	ns
8	CASx Asserted before Column Address Invalid	15	—	ns
9	RASx Pulse Width	2T	—	ns
10	CASx Pulse Width	(k-1)T	—	ns
11	CASx Precharge Time	T	—	ns
12	RASx Negated to CASx Negated	0	—	ns

13	Data-In Hold after $\overline{\text{CASx}}$ Negated	0	—	ns
14	$\overline{\text{OE}}$ Negated after $\overline{\text{CASx}}$ Negated	0	2	ns

NOTE: k is the number of system clocks for each DMA transfer in the page access cycle.
 T is the system clock period.
 $\overline{\text{RASx}}$ stands for $\overline{\text{RAS0}}$ and $\overline{\text{RAS1}}$.
 $\overline{\text{CASx}}$ stands for $\overline{\text{CAS0}}$ and $\overline{\text{CAS1}}$.

18.3.12 LCD Controller Timing

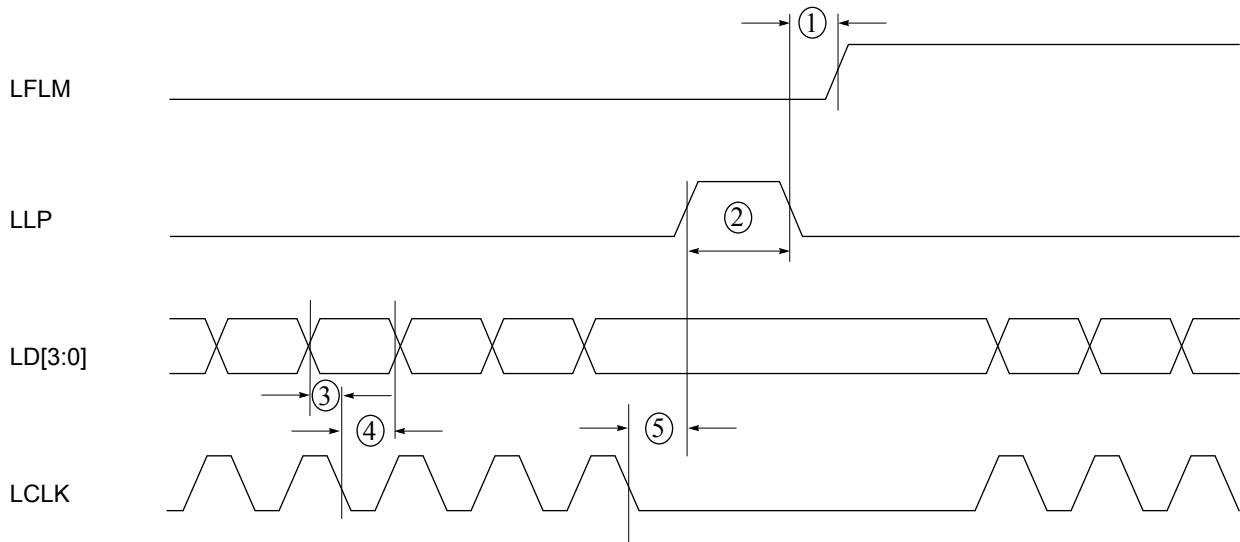

NUM	CHARACTERISTIC	3.3V		UNIT
		MINIMUM	MAXIMUM	
1	Line Pulse to Frame Signal	45	—	ns
2	Line Pulse Width	250	—	ns
3	LCD Data Setup	20	—	ns
4	LCD Data Hold	20	—	ns
5	Shift Clock to Line Pulse	50	—	ns

NOTE: This table contains the assumed active high logic for LFLM, LLP, and LCLK. The active edge is alternated if the polarity of the corresponding signal is modified.

18.3.13 Normal Mode Timing



18.3.14 Normal Mode and Emulation Mode Timing

NUM	CHARACTERISTIC	3.3V		UNIT
		MINIMUM	MAXIMUM	
1	EMUIRQ, EMUBRK and HIZ setup time	10	—	ns
2	EMUIRQ, EMUBRK and HIZ hold time	20	—	ns

18.3.15 Emulation Mode Timing

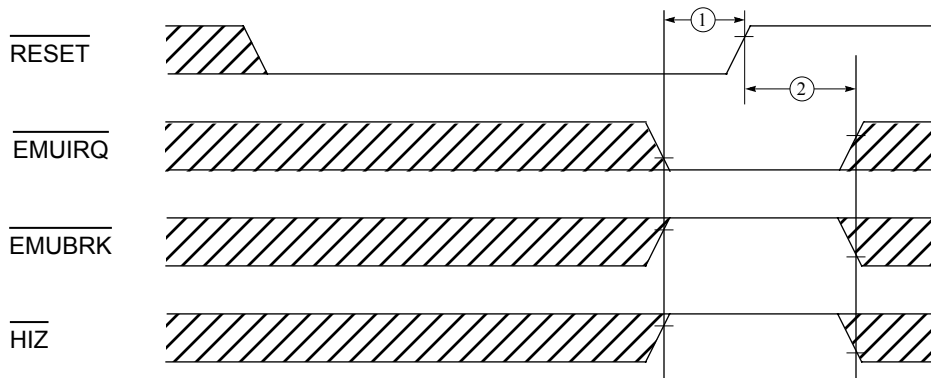

18.3.16 Bootstrap Mode Timing



NUM	CHARACTERISTIC	3.3V		UNIT
		MINIMUM	MAXIMUM	
1	EMUIRQ, EMUBRK and HIZ setup time	10	—	ns
2	EMUIRQ, EMUBRK and HIZ hold time	20	—	ns



SECTION 19 MECHANICAL DATA AND ORDERING INFORMATION

19.1 ORDERING INFORMATION

PACKAGE TYPE	FREQUENCY (MHZ)	TEMPERATURE	ORDER NUMBER
100-Lead TQFP	16.58MHz	0 - 70° C	XC68EZ328PU16V
144-Lead PBGA	16.58MHz	0 - 70° C	XC68EZ328ZC16V

Contact your local Motorola sales office for information on speed grades and part numbers.



19.2 TQFP PIN ASSIGNMENTS

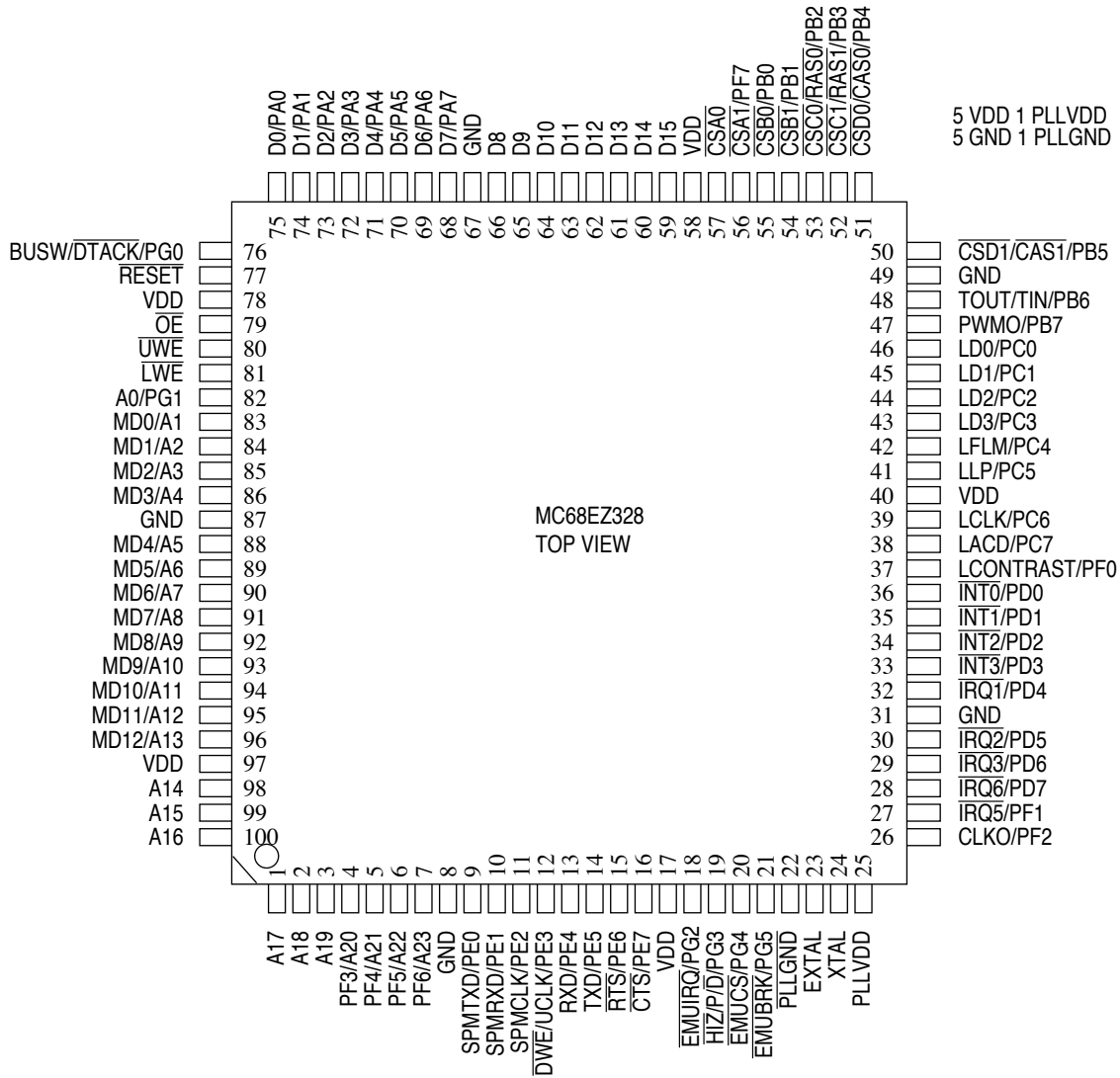
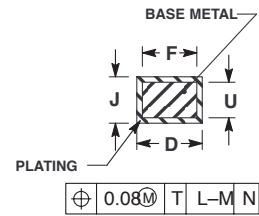
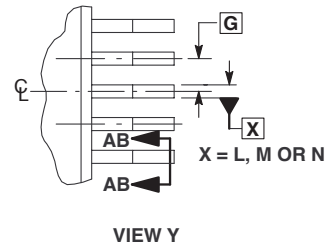
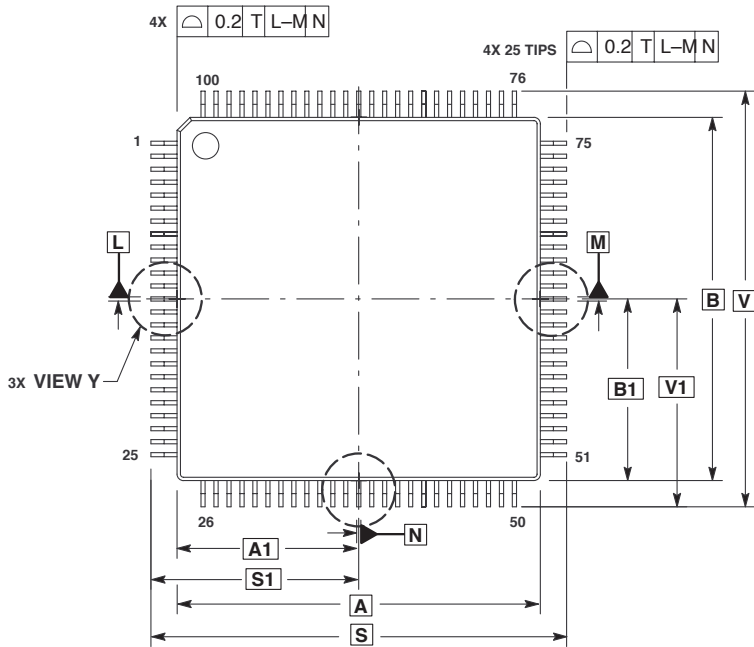

Figure 19-1. Top View

19.3 TQFP PACKAGE DIMENSIONS

The following figures illustrate the TQFP 14x14mm package, which has 0.5mm spacing between the pads. The device designator for the MC68EZ328 package is PU. For more information on the printed circuitboard layout of the 100-lead plastic thin-quad flat package (TQFP), including thermal via design and suggested pad layout, contact your local Motorola sales office.



SECTION AB-AB
ROTATED 90° CLOCKWISE

NOTES:

1. DIMENSIONS AND TOLERANCES PER ASME Y14.5M1994.
2. DIMENSIONS IN MILLIMETERS.
3. DATUMS, MANDATED TO BE DETERMINED AT THE SEATING PLANE DATUM.
4. DIMENSIONS AND V TO BE DETERMINED AT SEATING PLANE DATUM.
5. DIMENSIONS AND B DO NOT INCLUDE MOLD PROTRUSION ALLOWABLE PROTRUSION 0.25 PER SIDE. DIMENSIONS AND B INCLUDE MOLD MISMATCH.
6. DIMENSION DOES NOT INCLUDE DAMBAR PROTRUSION DAMBAR PROTRUSION SHALL NOT CAUSE HEAD WIDTH TO EXCEED 0.35. MINIMUM GAP BETWEEN PROTRUSION AND ADJACENT LEAD OR PROTRUSION 0.7.

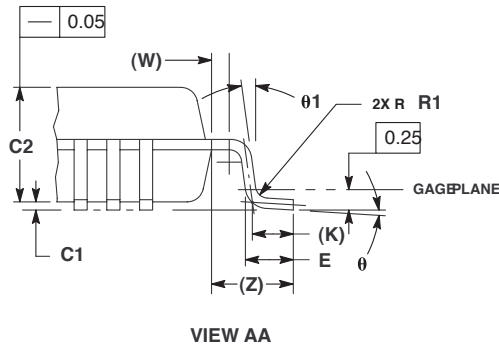
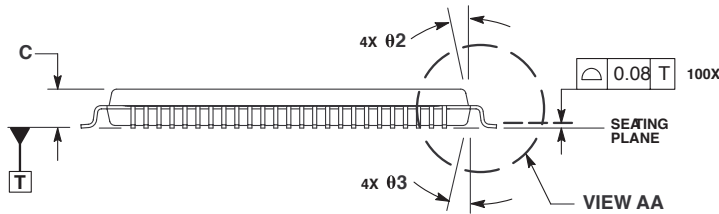

MILLIMETERS		
DIM	MIN	MAX
A	14.0	BSC
A1	7.0	BSC
B	14.0	BSC
B1	7.0	BSC
C	—	1.70
C1	0.05	0.20
C2	1.30	1.50
D	0.10	0.30
E	0.45	0.75
F	0.15	0.23
G	0.50	BSC
J	0.07	0.20
K	0.50	REF
R1	0.08	0.20
S	16.0	BSC
S1	8.0	BSC
U	0.09	0.16
V	16.0	BSC
V1	8.0	BSC
W	0.20	REF
Z	1.00	REF
θ	0°	7°
θ1	0°	—
Ø2	12°	REF
Ø3	12°	REF

19.4 PBGA PIN ASSIGNMENTS

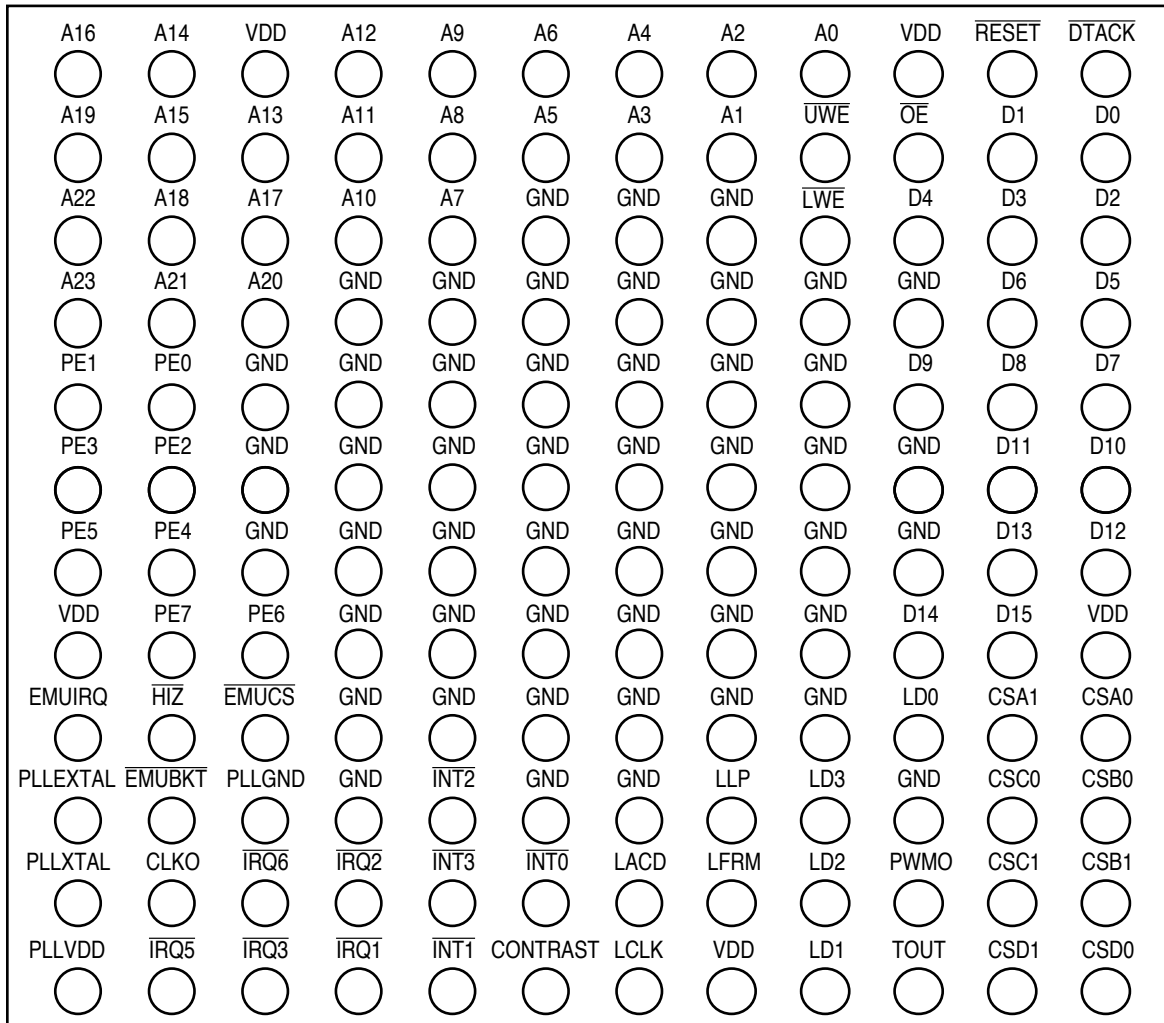

19.5 PBGA PACKAGE DIMENSIONS

The following figures illustrate the PBGA 13x13mm package, which has 1mm spacing between the pads. The device designator for the MC68EZ328 package is ZC. For more information on the printed circuitboard layout of the 144-lead plastic ball-grid array package (PBGA), including thermal via design and suggested pad layout, contact your local Motorola sales office.

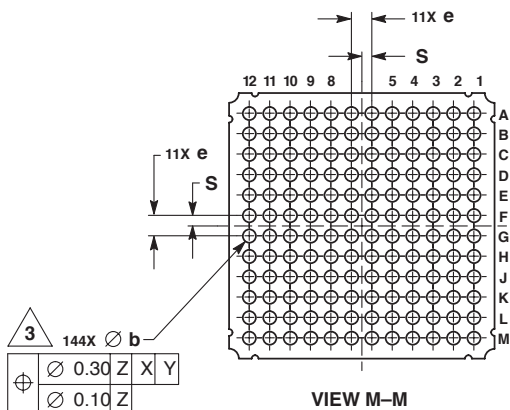
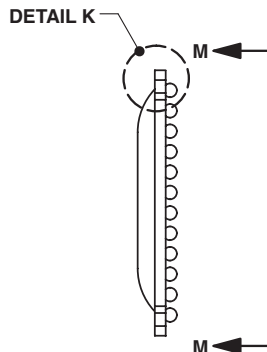
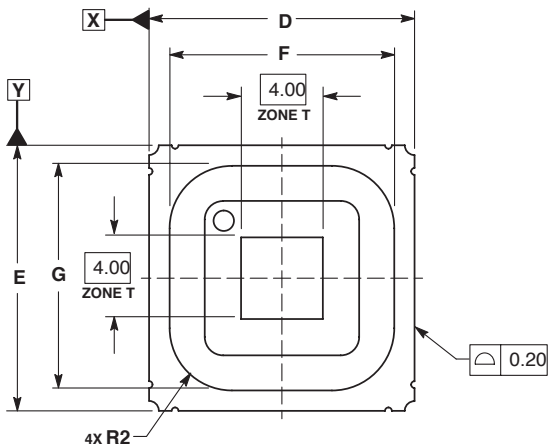

NOTES:

1. DIMENSIONS ARE IN MILLIMETERS.
2. INTERPRET DIMENSIONS AND TOLERANCES PER ASME Y14.5M 1994.
3. DIMENSION IS MEASURED AT THE MAXIMUM SOLD BALL DIAMETER PARALLEL TO DATUM PLANE Z.
4. DATUM Z (SEATING PLANE) IS DEFINED BY THE SPHERICAL CROWN OF THE SOLD BALLS.
5. PARALLELISM REQUIREMENTS APPLY TO ZONE T ONLY. PARALLELISM MEASUREMENTS SHALL EXCLUDE ANY EFFECT OF FLASHER MARK ON TOP SURFACE OF PACKAGE.

MILLIMETERS		
DIM	MIN	MAX
A	1.32	1.75
A1	0.27	0.47
A2	0.36 REF	
A3	0.70	1.00
b	0.35	0.65
D	13.00 BSC	
E	13.00 BSC	
e	1.00 BSC	
F	9.00	13.00
G	9.00	13.00
R1	2.50 REF	
R2	0.40	2.50
S	0.50 BSC	

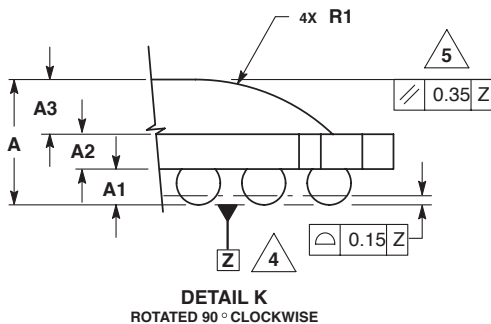



INDEX

Symbols

, 2-5, 2-6, 2-7, 2-9, 12-3

Numerics

/PB 2-9
 CSB 2-9
 CSC 2-9
 CSD 2-9
 signals
 chip-select
 CSB 2-9
 CSC 2-9
 CSD 2-9
 MD 2-5
 signals
 data bus
 MD 2-5
 /A 2-5
 D 2-5
 signals
 data bus
 D 2-5
 A 2-5
 signals
 address bus
 A 2-5
 A 2-5
 signals
 address bus
 A 2-5
 /PB 2-9
 /PC 2-7
 INT 2-6
 IRQ 2-6
 LD 2-7
 signals
 LD 12-3
 interrupt controller
 INT 2-6
 LCD controller
 LD 2-7
 interrupt controller
 IRQ 2-6
 /PB 2-9

/PF 2-5
 68K familiarity, 1-1
 /PA 2-5
 D 2-5
 IRQ6/PD 2-6
 signals
 data bus
 D 2-5
 interrupt controller
 IRQ6/PD 2-6

A

A0/PG1 signal, 2-5
 address multiplexing, 14-2
 address space of on-chip resources, 3-1
 address space of the internal peripheral registers,
 3-1
 addresses, 1-9
 alarm, of the real-time clock, 13-3
 A-line insertion unit, 15-3
 applications
 17-1
 design checklist, 17-1
 using the MC68EZ328ADS board, 17-2
 architecture
 1-1
 bootstrap mode, 1-8
 chip-selects, 1-6
 core, 1-2
 DRAM controller, 1-8
 in-circuit emulation, 1-8
 interrupt controller, 1-7
 LCD controller, 1-8
 memory map, 1-8
 parallel ports, 1-7
 PLL and power, 1-6
 pulse-width modulator, 1-7
 real-time clock, 1-8
 serial peripheral interface, 1-7
 timer, 1-7
 UART, 1-8
 AS pin, 3-1
 assertion (definition), 2-1
 assumptions, 1-1
 audio (see sound) 8-1

B

- baud rate generator (UART), 11-6
- BERR pin, 3-1
- block diagrams
 - baud rate generator, 11-6
 - DRAM controller, 14-1
 - in-circuit emulation, 15-1
 - LCD controller, 12-2
 - MC68EZ328, 1-2
 - phase-locked loop, 5-1
 - power control, 5-7
 - pulse-width modulator, 8-1
 - real-time clock, 13-2
 - serial peripheral interface master, 10-1
 - timer, 9-1
 - UART, 11-2
- bootloader (flowchart), 16-6
- bootstrap mode
 - 16-1
 - application programming example, 16-4
 - bootloader flowchart, 16-6
 - features, 16-1
 - instruction buffer usage example, 16-5
 - operation
 - 16-1
 - bootstrap record format, 16-2
 - changing communication speed, 16-3
 - entering bootstrap mode, 16-1
 - setting up RS-232 terminal, 16-3
 - system initialization example, 16-3
- bootstrap mode, 1-8
- Break characters, sending, 11-4
- breakpoints, 15-2
- b-records, 16-2
- bus bandwidth obstruction, minimizing, 12-8
- bus interface, 1-6
- bus time-out control and status, 3-1
- bus width, selecting the initial, 4-3
- BUSW/DTACK/PG0 signal, 2-6

C

- chip-select
 - not operating, 4-4
 - setting the start address, 4-4
- chip-select group base address registers (CSGBA-CSGBD), 4-4
- chip-select logic
 - 4-1
 - boot device, 4-4
 - enabling, 4-8
 - operation
 - programmable data bus size, 4-3
 - protecting memory, 4-2

- operation, 4-2
- programming
 - example, 4-9
 - programming, 4-4
 - setting the memory range, 4-8
 - setting to read-only, 4-6
 - setting to supervisor-only, 4-6
- chip-select registers A-D (CSA, CSB, CSC, CSD), 4-5
- chip-selects
 - 1-6
- CLK32, status, 5-5
- CLKO pin, enabling, 5-5
- CLKO/PF2 signal, 2-4
- clock source, 5-1
- clock synthesizer, 1-6
- CMOS level, driving to, 2-3
- communication polling, 13-3
- communication speed, changing, 16-3
- communication, 10-1
- configuration
 - 1-8
- core
 - 1-2
 - features, 1-2
 - instruction set, 1-5
 - modes, 1-4
 - programming, 1-2
- crystal degradation, 12-4
- CSA0 signal, 2-9
- CSA1/PF7 signal, 2-9
- CSA-CSD (definition), 4-5
- CSGBA-CSGBD (definition), 4-4
- CTS/PE7 signal, 2-8
- current requirements, 18-1
- cursor
 - blink control, 12-13
 - format, 12-5
 - horizontal position, 12-11
 - vertical position, 12-12
 - width and height, 12-12

D

- data
 - mapping, 12-6
 - retention during reset, 14-5
- data bus size, programming, 4-3
- data, transferring between devices, 10-1
- data, transporting in character blocks, 11-1
- DAYALARM (definition), 13-12
- DAYR (definition), 13-12
- design checklist, 17-1
- digitizer sampling, 13-3
- DMA controller, 12-8

documentation, related, xvii
 double-mapping, 3-3
 DragonBall, xvii
 DRAM control register (DRAMC), 14-8
 DRAM controller
 14-1
 block diagram, 14-1
 features, 14-1
 operation
 8-bit mode, 14-4
 address multiplexing, 14-2
 data retention during reset, 14-5
 generating DTACK, 14-3
 LCD interface, 14-3
 low-power standby mode, 14-4
 refresh control, 14-3
 operation, 14-2
 programming, 14-6
 DRAM controller, 1-8
 DRAM memory configuration register (DRAMMC), 14-6
 DRAM, selecting, 4-7
 DRAMC (definition), 14-8
 DRAMMC (definition), 14-6
 DTACK generation, 14-3
 DWE/UCLK/PE3 signal, 2-6

E

efficiency, 5-6
 electricals
 18-1
 AC characteristics, 18-2
 DC characteristics, 18-1
 maximum ratings, 18-1
 EMUBRK/PG5 signal, 2-9
 EMUCS (definition), 4-8
 EMUCS/PG4 signal, 2-9
 EMUIRQ/PG2 signal, 2-9
 emulation chip-select (EMUCS) register, 4-8
 emulation mode, entering, 15-2
 errors
 bus, 4-6
 on the LCD panel, 12-5
 examples
 application programming, 16-4
 chip-select programming, 4-9
 ICEM application development, 15-12
 ICEM typical programming example, 15-8
 instruction buffer usage, 16-5
 programming plug-in emulator, 15-10
 programming the LCD controller, 12-19
 programming UART non-integer prescaler, 11-19
 pulse-width modulator programming, 8-6

serial peripheral interface master
 programming, 10-5
 system initialization, 16-3
 exception vector (definition), 6-3
 exceptions, causes of, 3-1
 EXTAL signal, 2-4

F

features
 bootstrap mode, 16-1
 core, 1-2
 DRAM controller, 14-1
 in-circuit emulation, 15-1
 LCD controller, 12-1
 MC68EZ328, 1-1
 phase-locked loop, 5-1
 real-time clock, 13-1
 timer, 9-1
 UART, 11-1
 FIFO status, 8-2
 frame rate control, 12-2
 frame rate modulation, controlling, 12-7
 frequency
 for sound, 8-1
 frequency, generating, 5-2

G

general-purpose timer (see timer) 1-7
 glitches, preventing, 7-2
 gray-scale tones, generating, 12-6

H

HIZ/P/D/PG3 signal, 2-9

I

ICEMACR (definition), 15-4
 ICEMAMR (definition), 15-4
 ICEMCCR (definition), 15-5
 ICEMCMR (definition), 15-5
 ICEMCR (definition), 15-6
 ICMSR (definition), 15-8
 ICR (definition), 6-7
 image width, 12-10
 IMR (definition), 6-9
 in-circuit emulation
 15-1
 application development example, 15-12
 block diagram, 15-1
 features, 15-1
 operation

- 15-2
 - A-line insertion unit, 15-3
 - breakpoints, 15-2
 - entering emulation mode, 15-2
 - interrupt gate, 15-3
 - signal decoder, 15-3
 - plug-in emulator design example, 15-10
 - programming, 15-4
 - typical programming example, 15-8
 - in-circuit emulation module address compare register (ICEMACR), 15-4
 - in-circuit emulation module address mask register (ICEMAMR), 15-4
 - in-circuit emulation module control compare register (ICEMCCR), 15-5
 - in-circuit emulation module control mask register (ICEMCMR), 15-5
 - in-circuit emulation module control register (ICEMCR), 15-6
 - in-circuit emulation module status register (ICEMSR), 15-8
 - in-circuit emulation, 1-8
 - infra-red communication, 1-8
 - infra-red mode, 11-2
 - instruction set, 1-5
 - interrupt
 - autovector, 6-4
 - clearing a PWM interrupt, 8-3
 - clearing a real-time clock interrupt, 13-7
 - clearing a SPIM interrupt, 10-5
 - clearing a timer interrupt, 9-5
 - error, 6-8
 - keyboard, 6-20
 - masking, 6-9
 - pen, 6-20
 - polarity, 6-7
 - port operation, 7-7
 - priority, 6-2
 - processing, 6-1
 - source, 6-11
 - sources, 6-1
 - interrupt control register (ICR), 6-7
 - interrupt controller
 - 6-1
 - exception vectors, 6-3
 - keyboard interrupts, 6-20
 - operation, 6-5
 - pen interrupts, 6-20
 - processing interrupts, 6-1
 - programming, 6-6
 - reset, 6-4
 - vector generator, 6-6
 - interrupt controller, 1-7
 - interrupt mask register (IMR), 6-9
 - interrupt pending register (IPR), 6-16
 - interrupt status register (ISR), 6-11
 - interrupt vector register (IVR), 6-6
 - interrupts
 - pending, 6-16
 - interrupts, from the keyboard, 5-6
 - introduction, getting started with your design, 17-1
 - IPR (definition), 6-16
 - IrDA (definition), 11-2
 - IrDA, operation, 11-7
 - IRQ5/PF1 signal, 2-6
 - ISR (definition), 6-11
 - IVR (definition), 6-6
- ## K
- keyboard debouncing, 13-3
- ## L
- LACD/PC7 signal, 2-7
 - LACDRC (definition), 12-14
 - LBLKC (definition), 12-13
 - LCD alternate crystal direction rate control register (LACDRC), 12-14
 - LCD blink control register (LBLKC), 12-13
 - LCD clocking control register (LCKCON), 12-15
 - LCD controller
 - block diagram, 12-2
 - features, 12-1
 - operation
 - connecting to an LCD panel, 12-3
 - control
 - cursor format, 12-5
 - screen format, 12-5
 - control, 12-4
 - low-power mode, 12-8
 - signals, 12-3
 - using the DMA
 - bus bandwidth, 12-8
 - using the DMA, 12-8
 - operation, 12-2
 - programming example, 12-19
 - programming, 12-9
 - LCD controller, 1-8
 - LCD cursor width and height register (LCWCH), 12-12
 - LCD cursor X position register (LCXP), 12-11
 - LCD cursor Y position register (LCYP), 12-12
 - LCD frame rate control modulation register (LFRCM), 12-17
 - LCD gray palette mapping register (LGPMR), 12-18
 - LCD panel
 - adjusting gray-scale density, 12-18
 - controlling the contrast, 12-18

controlling, 12-4
 fetching data, 12-9
 height, 12-11
 interface configuration, 12-13
 interface signal polarity, 12-14
 minimizing flicker, 12-17
 timing, 12-3
 turning it off, 12-8
 width, 12-10

LCD panel interface configuration register (LPICF), 12-13

LCD panel, connecting to, 12-3

LCD panning offset register (LPOSR), 12-17

LCD pixel clock divider register (LPXCD), 12-15

LCD polarity configuration register (LPOLCF), 12-14

LCD refresh rate adjustment register (LRRR), 12-16

LCD screen height register (LYMAX), 12-11

LCD screen starting address register (LSSA), 12-9

LCD screen width register (LXMAX), 12-10

LCD virtual page width register (LVPW), 12-10

LCKCON (definition), 12-15

LCLK/PC6 signal, 2-7

LCONTRAST/PF0 signal, 2-7

LCWCH (definition), 12-12

LCXP (definition), 12-11

LCYP (definition), 12-12

LFLM/PC4 signal, 2-7

LFRCM (definition), 12-17

LGPMR (definition), 12-18

LLP/PC5 signal, 2-7

LPICF (definition), 12-13

LPOLCF (definition), 12-14

LPOSR (definition), 12-17

LPXCD (definition), 12-15

LRRR (definition), 12-16

LSSA (definition), 12-9

LVPW (definition), 12-10

LWE signal, 2-6

LXMAX (definition), 12-10

LYMAX (definition), 12-11

M

MC68EZ328

applications, 17-1

architecture

- block diagram, 1-2
- bootstrap mode, 1-8
- chip-select logic, 1-6
- core
 - programming, 1-2
 - core, 1-2
- DRAM controller, 1-8
- features, 1-1
- in-circuit emulation, 1-8

- instructions, 1-5
- interrupt controller, 1-7
- LCD controller, 1-8
- memory map, 1-8
- parallel ports, 1-7
- PLL and power, 1-6
- pulse-width modulator, 1-7
- real-time clock, 1-8
- serial peripheral interface, 1-7
- timer, 1-7
- UART and infra-red support, 1-8

basic architecture, 1-1

bootstrap mode, 16-1

chip-select logic

- programming
 - overlapping registers, 4-4

general-purpose timer, 9-1

interrupt controller, 6-1

LCD controller, 12-1

mechanical data, 19-1

ordering information, 19-1

parallel ports, 7-1

phase-locked loop and power control, 5-1

preface, xvii

pulse-width modulator, 8-1

serial peripheral interface master, 10-1

signal descriptions

- address bus signals, 2-5
- bus control signals, 2-6
- chip-select signals, 2-9
- clock and system control signals, 2-4
- data bus signals, 2-5
- grouped by function, 2-2
- in-circuit emulation signals, 2-9
- interrupt controller signals, 2-6
- LCD controller signals, 2-7
- power and ground signals, 2-4
- pulse-width modulator signal, 2-8
- serial peripheral interface signals, 2-8
- timer signal, 2-8
- UART controller signals, 2-8

signal descriptions, 2-1

system control, 3-1

MC68EZ328ADS board, using the, 17-2

mechanicals

- 19-1
- PBGA packaging, 19-4
- PBGA pin assignments, 19-4
- TQFP packaging, 19-2
- TQFP pin assignments, 19-2

memory map (table), 1-8

memory protection, 4-2

memory size, selecting, 4-5

memory type, selecting, 4-5

memory, controlling, 4-4

modes	2 683719 v
address, 1-4	2 687731 v
bootstrap, 1-8, 16-1	2 689091 xiii
changing, 6-8, 7-2	2 690189 xv
DRAM 8-bit, 14-4	2 691588 v
DRAM low-power standby, 14-4	2 691595 v
EDO, 14-2	2 691602 v
Fast Page, 14-2	2 691606 v
LCD low-power, 12-8	2 691607 v
power control, 5-8	2 691612 v
pulse-width modulator	2 692776 xv
8-1	2 692841 v
D/A, 8-2	2 692849 xv
playback, 8-1	openObjectId ez328_10
tone, 8-2	2 292573 viii
selecting clock mode, 11-9	2 292575 viii
supervisor/user, 1-3	2 292908 viii
timer free-run, 9-2	2 294318 viii
timer restart, 9-2	2 294589 xiii
trace, 1-3	2 295826 viii
UART	2 296427 viii
IrDA, 11-2	2 296619 viii
NRZ, 11-2	2 298363 xiii
receiver	2 299526 viii
asynchronous, 11-5	openObjectId ez328_11
synchronous, 11-5	2 292864 viii
	2 292872 viii
	2 293331 viii
	2 293586 viii
	2 293830 viii
	2 293844 viii
	2 294604 viii
	2 295328 viii
	2 296512 viii
	2 296524 viii
	2 296605 viii
	2 296660 viii
	2 343857 viii
	2 345898 viii
	2 347375 xiii
	2 347470 viii
	2 347533 xiii
	2 347595 xiii
	2 348038 xiii
	2 348360 viii
	2 348519 xv
	2 348611 xv
	2 348696 viii
	2 348745 xv
	openObjectId ez328_12
	2 10090 ix
	2 10368 viii
	2 279 viii
	2 6110 xiii
	2 738322 ix
N	
negation (definition), 2-1	
NIPR (definition), 11-18	
Non-Return to Zero mode, 11-2	
NRZ (definition), 11-2	
O	
OE signal, 2-6	
openObjectId ez328.preface	
2 669497 v	
2 675538 v	
2 675592 v	
openObjectId ez328_1	
2 289423 v	
2 289432 v	
2 289513 xiii	
2 669679 v	
2 669685 v	
2 669694 v	
2 669701 v	
2 669710 v	
2 669717 v	
2 669816 xiii	
2 676207 v	
2 676950 v	
2 683333 xiii	

2 779825	ix	2 575622	x
2 779943	ix	2 580541	xiii
2 780059	ix	2 582124	xiii
2 780421	ix	2 583814	xiv
2 780552	ix	2 583815	x
2 780615	ix	2 584157	xiv
2 780683	ix	2 584905	x
2 780811	ix	2 584917	x
2 780941	ix	openObjectld ez328_15	
2 781067	ix	2 1002070	x
2 781080	ix	2 1002153	xiv
2 781426	viii	2 1004400	x
2 781452	viii	2 1004973	xiv
2 781647	viii	2 1006712	x
2 790133	ix	2 427142	x
2 791446	ix	2 427288	x
2 793634	xiii	2 427293	x
2 794233	xiii	2 431764	x
2 794588	xv	2 431929	x
2 798277	ix	2 431932	x
2 800606	ix	2 431934	x
2 801049	ix	2 432009	x
2 802339	ix	2 432262	x
2 802972	xiii	2 433563	x
2 803422	ix	2 434009	x
2 803579	ix	2 435841	x
openObjectld ez328_13		2 435859	x
2 1001760	ix	2 996801	x
2 1003365	ix	2 997667	x
2 1005439	ix	2 997954	xiv
2 1005798	ix	2 997959	xiv
2 1006357	ix	2 999013	x
2 427132	ix	2 999627	x
2 427291	ix	openObjectld ez328_16	
2 427486	ix	2 1000677	x
2 427649	ix	2 1000774	x
2 427959	ix	2 1001076	x
2 428078	ix	2 1001345	x
2 428677	ix	2 1001394	x
2 428784	ix	2 1002023	x
2 430127	ix	2 1002520	x
2 430649	ix	2 1005276	x
2 805535	xv	2 1005547	xiv
2 805693	ix	2 1006548	x
2 999478	xiii	2 1006642	xiv
2 999519	ix	2 1006729	xi
openObjectld ez328_14		2 427132	x
2 292769	ix	openObjectld ez328_17	
2 299719	x	2 673577	xi
2 3087	ix	2 675093	xi
2 3088	x	2 675726	xi
2 3089	x	openObjectld ez328_18	
2 3090	x	2 11810	xi
2 3111	x	2 11942	xi
2 3126	x	2 15441	xi

2 15443 xi	2 51560 vi
2 15630 xi	2 51569 vi
2 16005 xi	2 51613 xiii
2 16372 xi	2 51700 vi
2 22729 xi	2 52568 vi
2 24255 xi	2 54224 vi
2 24591 xi	2 54366 vi
2 25013 xi	openObjectld ez328_5
2 25370 xi	2 260053 vi
2 25590 xi	2 260055 vi
2 25715 xi	2 260062 vi
2 29229 xi	2 260067 vi
2 30482 xi	2 260069 vi
2 34497 xi	2 260098 vi
2 34546 xi	2 294112 xiii
2 34549 xi	2 294149 vi
2 34554 xi	2 294151 vi
openObjectld ez328_19	2 294336 vi
2 296427 xi	2 295406 vi
2 298631 xi	2 295446 vi
2 298649 xi	2 295821 xiii
2 298688 xi	2 295870 xiii
2 299398 xi	2 300732 vi
2 299675 xiv	2 301365 vi
2 299676 xi	openObjectld ez328_6
openObjectld ez328_2	2 29439 vii
2 1439 v	2 40040 vii
2 1447 v	2 41586 vii
2 1482 v	2 45102 vii
2 1491 v	2 46577 vii
2 1529 vi	2 46579 vii
2 1546 vi	2 47361 xv
2 1997 v	2 49000 vii
2 298052 xiii	2 52213 vii
2 298569 xiii	2 52456 xv
2 298639 v	2 55308 vii
2 300388 v	2 57424 vii
2 3557 vi	2 57563 vii
2 3592 vi	2 57625 xiii
2 3622 xv	2 57637 vii
2 3751 v	2 59397 vii
2 3765 v	2 59399 vii
2 3785 vi	2 61014 vi
2 3795 vi	openObjectld ez328_7
openObjectld ez328_3	2 29156 vii
2 1553 vi	2 42807 xiii
2 4152 vi	2 43503 vii
2 46113 vi	2 44169 vii
2 46732 vi	2 44507 vii
openObjectld ez328_4	2 48549 vii
2 10460 vi	2 48666 xiii
2 1579 vi	2 49364 vii
2 37257 vi	2 50949 vii
2 46128 vi	2 51131 vii
2 51552 xiii	2 51855 vii

2 52048 vii
 openObjectId ez328_8
 2 295745 vii
 2 295747 vii
 2 295906 vii
 2 296041 vii
 2 296174 vii
 2 297135 vii
 2 298912 vii
 2 300655 vii
 2 300746 xiii
 2 300761 vii
 2 300799 vii
 2 301409 vii
 2 301487 xiii
 openObjectId ez328_9
 2 291854 viii
 2 295650 viii
 2 296523 viii
 2 296691 viii
 2 296832 viii
 2 296974 viii
 2 297423 viii
 2 299282 vii
 2 301423 vii
 2 301526 xiii
 operation
 bootloader program, 16-6
 bootstrap mode, 16-1
 chip-select logic, 4-2
 DRAM controller, 14-2
 in-circuit emulation, 15-2
 interrupt controller, 6-5
 interrupt port, 7-7
 keyboard interrupts, 6-20
 LCD controller, 12-2
 parallel ports, 7-1
 pen interrupts, 6-20
 phase-locked loop, 5-2
 ports, 7-1
 power control, 5-8
 pulse-width modulator, 8-1
 real-time clock, 13-2
 serial peripheral interface master, 10-1
 system control, 3-1
 timer, 9-1
 UART
 sub-block, 11-4
 UART (serial), 11-2
 ordering parts, 19-1
 organization of the manual, xvii
 overlapping registers, 4-4

P

package dimensions
 PBGA, 19-4
 TQFP, 19-2
 PADATA (definition), 7-2
 PADIR (definition), 7-2
 PANEL_OFF signal, 12-8
 PAPUEN (definition), 7-2
 parallel ports
 7-1
 operation, 7-1
 programming, 7-2
 parallel ports, 1-7
 parity errors, generating, 11-4
 parts, ordering, 19-1
 PBDATA (definition), 7-3
 PBDIR (definition), 7-3
 PBGA package dimensions, 19-4
 PBPUEN (definition), 7-3
 PBSEL (definition), 7-3
 PCDATA (definition), 7-5
 PCDIR (definition), 7-5
 PCPDEN (definition), 7-5
 PCSEL (definition), 7-5
 PCTLR (definition), 5-9
 PDDATA (definition), 7-7
 PDDIR (definition), 7-7
 PDIQEG (definition), 7-7
 PDIQEN (definition), 7-7
 PDKBEN (definition), 7-7
 PDPOL (definition), 7-7
 PDPUEN (definition), 7-7
 PDSEL (definition), 7-7
 PEDATA (definition), 7-10
 PEDIR (definition), 7-10
 PEPUEN (definition), 7-10
 permission from the internal peripheral registers, 3-1
 PESEL (definition), 7-10
 PFDATA (definition), 7-12
 PFDIR (definition), 7-12
 PFPUEN (definition), 7-12
 PFSEL (definition), 7-12
 PGDATA (definition), 7-14
 PGDIR (definition), 7-14
 PGPUEN (definition), 7-14
 PGSEL (definition), 7-14
 phase configuration, 10-2
 phase-locked loop
 5-1
 block diagram, 5-1
 disabling, 5-1, 5-5
 features, 5-1
 operation

- 5-2
 - at power-up, 5-2
 - at system shut-down, 5-3
 - at wake-up, 5-2
 - changing VCO frequency, 5-3
 - reducing power consumption, 5-2
- programming, 5-4
- phase-locked loop and power, 1-6
- pin assignment
 - PBGA, 19-4
 - TQFP, 19-2
- pins (see signals) 2-1
- PLL (definition), 5-1
- PLL control register (PLLCR), 5-4
- PLL frequency select register (PLLFSR), 5-5
- PLL VDD signal, 2-4
- PLL VSS signal, 2-4
- PLLCR (definition), 5-4
- PLLFSR (definition), 5-5
- polarity configuration, 10-2
- port A data register (PADATA), 7-2
- port A direction register (PADIR), 7-2
- port A pull-up enable register (PAPUEN), 7-2
- port B data direction register (PBDIR), 7-4
- port B data register (PBDIR), 7-4
- port B pull-up enable register (PBPUEEN), 7-4
- port B select register (PBSEL), 7-4
- port C data register (PCDATA), 7-5
- port C direction register (PCDIR), 7-5
- port C pull-down enable register (PCPDEN), 7-5
- port C select register (PCSEL), 7-5
- port D data register (PDDATA), 7-8
- port D direction register (PDDIR), 7-8
- port D interrupt request edge register (PDIQEG), 7-9
- port D interrupt request enable register (PDIRQEN), 7-9
- port D keyboard enable register (PDKBEN), 7-9
- port D polarity register (PDPOL), 7-9
- port D pull-up enable register (PDPUEEN), 7-8
- port D select register (PDSEL), 7-8
- port E data register (PEDATA), 7-11
- port E direction register (PEDIR), 7-11
- port E pull-up enable register (PEPUEEN), 7-11
- port E select register (PESEL), 7-11
- port F data register (PFDATA), 7-12
- port F direction register (PFDIR), 7-12
- port F pull-up enable register (PFPUEN), 7-12
- port F select register (PFSEL), 7-12
- port G data register (PGDATA), 7-14
- port G direction register (PGDIR), 7-14
- port G pull-up enable register (PGPUEN), 7-15
- port G select register (PGSEL), 7-15
- ports (see parallel ports) 1-7
- power control
 - 5-6
 - block diagram, 5-7
 - operation
 - 5-8
 - doze mode, 5-8
 - normal mode, 5-8
 - sleep mode, 5-8
 - saving power, 6-20
- power control register (PCTLR), 5-9
- power, conserving, 5-1
- privilege violation, 3-2
- programming
 - application example, 16-4
 - chip-select example, 4-9
 - chip-select logic, 4-4
 - core, 1-2
 - DRAM controller, 14-6
 - ICEM application development example, 15-12
 - in-circuit emulation, 15-4
 - instruction buffer usage example, 16-5
 - instruction set, 1-5
 - interrupt controller, 6-6
 - LCD controller example, 12-19
 - LCD controller, 12-9
 - non-integer prescaler example, 11-19
 - parallel ports, 7-2
 - phase-locked loop, 5-4
 - plug-in emulator example, 15-10
 - pulse-width modulator example, 8-6
 - pulse-width modulator, 8-2
 - real-time clock, 13-4
 - serial peripheral interface master, 10-3
 - SPIM example, 10-5
 - system control, 3-2
 - system initialization example, 16-3
 - timer, 9-2
 - typical ICEM example, 15-8
 - UART, 11-8
- protecting your system, 3-1
- pulses, time between, 9-2
- pulse-width modulator
 - operation
 - 8-1
 - D/A mode, 8-2
 - playback mode, 8-1
 - tone mode, 8-2
 - programming example, 8-6
 - programming, 8-2
 - pulse-width modulator contrast control register (PWMR), 12-18
 - pulse-width modulator control register (PWMC), 8-2
 - pulse-width modulator counter (PWMCNT) register, 8-6
 - pulse-width modulator period (PWMP) register, 8-5

pulse-width modulator sample (PWMS) register, 8-5
 pulse-width modulator, 1-7
 PWM (definition), 8-1
 PWMC (definition), 8-2
 PWMCNT (definition), 8-6
 PWMO/PB7 signal, 2-8
 PWMP (definition), 8-5
 PWMR (definition), 12-18
 PWMS (definition), 8-5

R

real-time clock
 13-1
 block diagram, 13-2
 features, 13-1
 operation
 13-2
 alarm, 13-3
 minute stopwatch, 13-4
 prescaler and counter, 13-2
 sampling timer, 13-3
 watchdog timer, 13-3
 programming, 13-4
 real-time clock alarm register (RTCALRM), 13-5
 real-time clock control register (RTCCTL), 13-6
 real-time clock day alarm register (DAYALARM), 13-12
 real-time clock day count register (DAYR), 13-12
 real-time clock hours, minutes, and seconds register (RTCTIME), 13-4
 real-time clock interrupt enable register (RTCENR), 13-9
 real-time clock interrupt status register (RTCISR), 13-7
 real-time clock, 1-8
 receiver (UART), 11-5
 reconstruction rate calculation, 8-5
 refresh control, 14-3
 register
 PWM contrast control, 12-18
 registers
 chip-select A-D, 4-5
 chip-select group base address A-D, 4-4
 core, 1-2
 cursor width and height, 12-12
 DRAM control, 14-8
 DRAM memory configuration, 14-6
 emulation chip-select, 4-8
 in-circuit emulation module address compare/mask, 15-4
 in-circuit emulation module control compare/mask, 15-5
 in-circuit emulation module control, 15-6
 in-circuit emulation module status, 15-8

interrupt control, 6-7
 interrupt mask, 6-9
 interrupt pending, 6-16
 interrupt status, 6-11
 interrupt vector, 6-6
 LACD rate control, 12-14
 LCD blink control, 12-13
 LCD clocking control, 12-15
 LCD cursor X position, 12-11
 LCD cursor Y position, 12-12
 LCD frame rate control modulation, 12-17
 LCD gray palette mapping, 12-18
 LCD panel interface configuration, 12-13
 LCD panning offset, 12-17
 LCD pixel clock divider, 12-15
 LCD polarity configuration, 12-14
 LCD refresh rate adjustment, 12-16
 LCD screen height, 12-11
 LCD screen starting address, 12-9
 LCD screen width, 12-10
 LCD virtual page width, 12-10
 PLL control, 5-4
 PLL frequency select, 5-5
 port A, 7-2
 port B, 7-3
 port C, 7-5
 port D, 7-7
 port E, 7-10
 port F, 7-12
 port G, 7-14
 power control, 5-9
 pulse-width modulator control, 8-2
 pulse-width modulator counter, 8-6
 pulse-width modulator period, 8-5
 pulse-width modulator sample, 8-5
 RTC alarm, 13-5
 RTC control, 13-6
 RTC day alarm, 13-12
 RTC day count, 13-12
 RTC hours, minutes, and seconds, 13-4
 RTC interrupt enable, 13-9
 RTC interrupt status, 13-7
 serial peripheral interface master control/status, 10-4
 serial peripheral interface master data, 10-3
 stopwatch minutes, 13-11
 system control (SCR), 3-2
 timer capture, 9-4
 timer compare, 9-4
 timer control, 9-2
 timer counter, 9-5
 timer prescaler, 9-4
 timer status, 9-5
 UART baud control, 11-11
 UART miscellaneous, 11-16

- UART non-integer prescaler, 11-18
- UART receiver, 11-12
- UART status/control, 11-8
- UART transmitter, 11-14
- watchdog timer, 13-5
- reset
 - 6-4
 - data bus width, 6-5
 - exception, 6-4
 - signals used, 6-5
- reset instruction, 6-4
- RESET signal, 2-4
- reset, causes of, 3-1
- RS-232 terminal, setting up, 16-3
- RTCALRM (definition), 13-5
- RTCCTL (definition), 13-6
- RTCIENR (definition), 13-9
- RTCISR (definition), 13-7
- RTCTIME (definition), 13-4
- RTS/PE6 signal, 2-8
- RXD/PE4 signal, 2-8

S

- sample repeats, 8-4
- SCR (definition), 3-2
- screen width and height, 12-5
- scrolling, 12-5
- serial communication, 11-1
- serial peripheral interface control/status register (SPIMCONT), 10-4
- serial peripheral interface master
 - block diagram, 10-1
 - operation
 - phase and polarity, 10-2
 - signals, 10-3
 - operation, 10-1
 - programming example, 10-5
 - programming, 10-3
- serial peripheral interface master data register (SPIMDATA), 10-3
- serial peripheral interface, 1-7
- signal decoder, 15-3
- signal, 2-5, 2-6, 2-7, 2-9
- signals
 - 2-1
 - address bus
 - 2-5
 - A0/PG1, 2-5
 - bus control
 - 2-6
 - BUSW/DTACK/PG0, 2-6
 - DWE/UCLK/PE3, 2-6
 - LWE, 2-6
 - OE, 2-6

- UWE, 2-6
- chip-select
 - 2-9
 - CSA0, 2-9
 - CSA1/PF7, 2-9
- clock and system control
 - CLKO/PF2, 2-4
 - EXTAL, 2-4
 - RESET, 2-4
 - XTAL, 2-4
- CTS/PE7, 11-3
- data bus
 - 2-5
- grouped by function (figure), 2-2
- grouped by function (table), 2-3
- in-circuit emulation
 - 2-9
 - EMUBRK/PG5, 2-9
 - EMUCS/PG4, 2-9
 - EMUIRQ/PG2, 2-9
 - HIZ/P/D/PG3, 2-9
- interrupt controller
 - 2-6
 - IRQ5/PF1, 2-6
- LACD/PC7, 12-3
- LCD controller
 - 2-7
 - LACD/PC7, 2-7
 - LCLK/PC6, 2-7
 - LCONTRAST/PF0, 2-7
 - LFLM/PC4, 2-7
 - LLP/PC5, 2-7
- LCLK/PC6, 12-3
- LFLM/PC4, 12-3
- LLP/PC5, 12-3
- power and ground, 2-4
- pulse-width modulator
 - 2-8
 - PWMO/PB7, 2-8
- RTS/PE6, 11-3
- RXD/PE4, 11-3
- serial peripheral interface
 - 2-8
 - SPMCLK/PE2, 2-9
 - SPMRXD/PE1, 2-8
 - SPMTXD/PE0, 2-8
 - SPMCLK/PE2, 10-3
 - SPMRXD/PE1, 10-3
 - SPMTXD/PE0, 10-3
- timer
 - 2-8
 - TOUT/TIN/PB6, 2-8
 - TXD/PE5, 11-3
- UART controller
 - 2-8

CTS/PE7, 2-8
 RTS/PE6, 2-8
 RXD/PE4, 2-8
 TXD/PE5, 2-8
 UCLK, 11-4
 sleep mode, putting the system in, 5-3
 sound
 generating, 8-1
 producing, 8-1
 SPIMCONT (definition), 10-4
 SPIMDATA (definition), 10-3
 SPMCLK/PE2 signal, 2-9
 SPMRXD/PE1 signal, 2-8
 SPMTXD/PE0 signal, 2-8
 stopwatch minutes register (STPWCH), 13-11
 STPWCH (definition), 13-11
 system control register, 3-2
 system operation
 3-1
 overview, 3-1
 programming, 3-2
 system, waking up, 5-3

T

TCMP (definition), 9-4
 TCN (definition), 9-5
 TCR (definition), 9-4
 TCTL (definition), 9-2
 timer
 block diagram, 9-1
 features, 9-1
 operation, 9-1
 programming, 9-2
 timer capture register (TCR), 9-4
 timer compare register (TCMP), 9-4
 timer control register (TCTL), 9-2
 timer counter register (TCN), 9-5
 timer prescaler register (TPRER), 9-4
 timer status register (TSTAT), 9-5
 timer, 1-7
 timing
 18-1
 bootstrap mode, 18-15
 chip-select flash write cycle, 18-5, 18-10
 chip-select read cycle, 18-3
 chip-select write cycle, 18-4
 DRAM read cycle (16-bit access), 18-6, 18-8,
 18-9
 DRAM write cycle (16-bit access), 18-7
 emulation mode, 18-14
 LCD controller, 18-13
 LCD DRAM DMA cycle (16-bit EDO mode
 access), 18-11, 18-12
 normal and emulation mode, 18-14

normal mode, 18-14
 tones, generating, 8-2
 touch panel support, 6-20
 TOUT/TIN/PB6 signal, 2-8
 TPRER (definition), 9-4
 TQFP package dimensions, 19-2
 transmitter (UART), 11-4
 TSTAT (definition), 9-5
 TTL levels supported, 2-3
 TXD/PE5 signal, 2-8

U

UART
 11-1
 baud rate generator block diagram, 11-6
 block diagram, 11-2
 features, 11-1
 operation
 serial
 IrDA, 11-2
 NRZ mode, 11-2
 signals, 11-3
 serial, 11-2
 sub-block
 11-4
 baud rate generator, 11-6
 receiver, 11-5
 transmitter, 11-4
 programming example, 11-19
 programming, 11-8
 UART (definition), 11-1
 UART baud control register (UBAUD), 11-11
 UART controller, 1-8
 UART miscellaneous register (UMISC), 11-16
 UART non-integer prescaler register (NIPR), 11-18
 UART receiver register (URX), 11-12
 UART status/control register (USTCNT), 11-8
 UART transmitter register (UTX), 11-14
 UBAUD (definition), 11-11
 UMISC (definition), 11-16
 universal asynchronous receiver/transmitter (see
 UART) 1-8, 11-1
 URX (definition), 11-12
 USTCNT (definition), 11-8
 UTX (definition), 11-14
 UWE signal, 2-6

V
 VDD signal, 2-4
 vector generator
 6-6
 vector number
 coding, 6-6

programming upper five bits, 6-6
vector number (definition), 6-3
VSS signal, 2-4

W

WATCHDOG (definition), 13-5
watchdog timer register (WATCHDOG), 13-5
word size of the boot device, 6-5
write-protect violation, 3-2

X

XTAL signal, 2-4

Freescale Semiconductor, Inc.

Freescale Semiconductor, Inc.

DragonBall and DragonBall-EZ are registered trademarks of Motorola, Inc.

Motorola reserves the right to make changes without further notice to any products herein. Motorola makes no warranty, representation or guarantee regarding the suitability of its products for any particular purpose, nor does Motorola assume any liability arising out of the application or use of any product or circuit, and specifically disclaims any and all liability, including without limitation consequential or incidental damages. "Typical" parameters which may be provided in Motorola data sheets and/or specifications can and do vary in different applications and actual performance may vary over time. All operating parameters, including "Typicals" must be validated for each customer application by customer's technical experts. Motorola does not convey any license under its patent rights nor the rights of others. Motorola products are not designed, intended, or authorized for use as components in systems intended for surgical implant into the body, or other applications intended to support life, or for any other application in which the failure of the Motorola product could create a situation where personal injury or death may occur. Should Buyer purchase or use Motorola products for any such unintended or unauthorized application, Buyer shall indemnify and hold Motorola and its officers, employees, subsidiaries, affiliates, and distributors harmless against all claims, costs, damages, and expenses, and reasonable attorney fees arising out of, directly or indirectly, any claim of personal injury or death associated with such unintended or unauthorized use, even if such claim alleges that Motorola was negligent regarding the design or manufacture of the part. Motorola and  are registered trademarks of Motorola, Inc. Motorola, Inc. is an Equal Opportunity/Affirmative Action Employer.

How to reach us:

USA/Europe/Locations Not Listed:

Motorola Literature Distribution
P.O. Box 5405
Denver, Colorado 80217
1 (800) 441-2447
1 (303) 675-2140

Asia/Pacific:

Motorola Semiconductors H.K. Ltd.
8B Tai Ping Industrial Park
51 Ting Kok Road
Tai Po, N.T., Hong Kong
852-26629298

Japan:

Nippon Motorola Ltd
SPD, Strategic Planning Office141
4-32-1, Nishi-Gotanda
Shinagawa-ku, Japan
81-3-5487-8488

Motorola Fax Back System (Mfax™):

TOUCHTONE (602) 244-6609
1 (800) 774-1848
RMFAX0@email.sps.mot.com

Internet:

<http://www.motorola.com/dragonball/>



MOTOROLA

**For More Information On This Product,
Go to: www.freescale.com**