

April 2000

1.0 Features

- Uses inexpensive fundamental-mode crystals
- Integrated phase-locked loops (PLL) multiply crystal frequency to the higher system frequencies needed
- 3.3V or 5V supply voltage available
- Small circuit board footprint (8-pin 0.150" SOIC)
- Custom frequency selections available - contact your local AMI Sales Representative for more information

2.0 Description

The FS6206 is a monolithic CMOS clock generator IC designed to minimize cost and component count.

An on-chip crystal oscillator generates the reference frequency and two phase-locked loops are used to generate precise output / reference frequency ratios. See Table 1 for information on the frequency ratios programmed into each version of the FS6206.

Figure 1: Pin Configuration

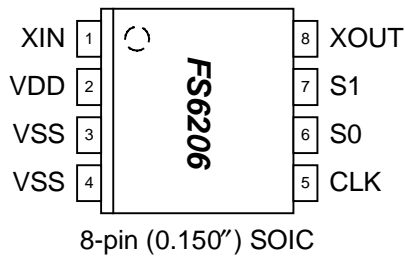
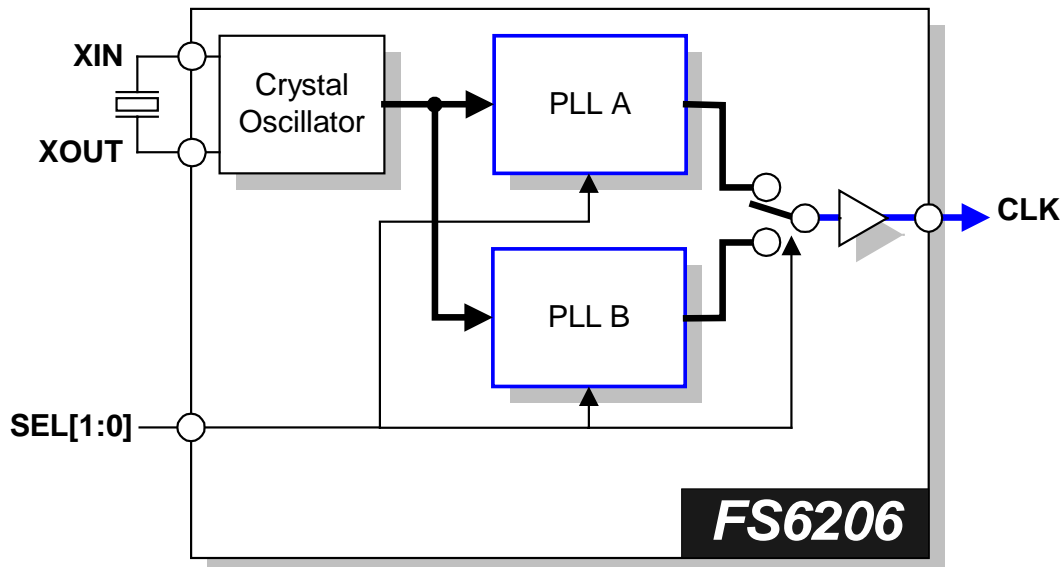

Table 1: Version Information

DEVICE	VDD	F _{REF} (MHz)	S1	S0	CLK (MHz)
FS6206-01	5.0	14.318182	0	0	0.0000 (Stopped Low)
			0	1	162.5239 (F _{REF} * 647 / 57)
			1	0	173.2151 (F _{REF} * 496 / 41)
			1	1	173.2343 (F _{REF} * 1101 / 91)

NOTE: Contact AMI for custom versions

Figure 2: Block Diagram



FS6206

Dual-PLL Clock Generator IC



April 2000

Table 2: Pin Descriptions

Key: AI = Analog Input; AO = Analog Output; DI = Digital Input; DI^U = Input with Internal Pull-Up; DI_D = Input with Internal Pull-Down; DIO = Digital Input/Output; DI-3 = Three-Level Digital Input, DO = Digital Output; P = Power/Ground; # = Active Low pin

PIN	TYPE	NAME	DESCRIPTION
1	AI	XIN	Crystal Oscillator Feedback
2	P	VDD	Power Supply (+3.3V or +5V) – see Version Information
3	P	VSS	Ground
4	P	VSS	Ground
5	DO	CLKB	Clock Output
6	DI ^U	S0	Control Input (see Table)
7	DI ^U	S1	Control Input (see Table)
8	AO	XOUT	Crystal Oscillator Drive

April 2000

3.0 Electrical Specifications

Table 3: Absolute Maximum Ratings

Stresses above those listed under Absolute Maximum Ratings may cause permanent damage to the device. These conditions represent a stress rating only, and functional operation of the device at these or any other conditions above the operational limits noted in this specification is not implied. Exposure to maximum rating conditions for extended conditions may affect device performance, functionality, and reliability.

PARAMETER	SYMBOL	MIN.	MAX.	UNITS
Supply Voltage ($V_{SS} = \text{ground}$)	V_{DD}	$V_{SS}-0.5$	7	V
Input Voltage, dc	V_I	$V_{SS}-0.5$	$V_{DD}+0.5$	V
Output Voltage, dc	V_O	$V_{SS}-0.5$	$V_{DD}+0.5$	V
Input Clamp Current, dc ($V_I < 0$ or $V_I > V_{DD}$)	I_{IK}	-50	50	mA
Output Clamp Current, dc ($V_I < 0$ or $V_I > V_{DD}$)	I_{OK}	-50	50	mA
Storage Temperature Range (non-condensing)	T_S	-65	150	°C
Ambient Temperature Range, Under Bias	T_A	-55	125	°C
Junction Temperature	T_J		125	°C
Lead Temperature (soldering, 10s)			260	°C
Input Static Discharge Voltage Protection (MIL-STD 883E, Method 3015.7)			2	kV



CAUTION: ELECTROSTATIC SENSITIVE DEVICE

Permanent damage resulting in a loss of functionality or performance may occur if this device is subjected to a high-energy electrostatic discharge.

Table 4: Operating Conditions

PARAMETER	SYMBOL	CONDITIONS/DESCRIPTION	MIN.	TYP.	MAX.	UNITS
Supply Voltage (3.3 volt system)	V_{DD}	SEE NOTE 1	3.0	3.3	3.6	V
Supply Voltage (5.0 volt system)	V_{DD}	SEE NOTE 1	4.5	5.0	5.5	V
Ambient Operating Temperature Range	T_A	SEE NOTE 1	0		70	°C
Crystal Resonator Frequency	f_{XTAL}	Fundamental Mode	5		18	MHz

NOTE 1: These specifications represent generic FS6206 device capability. Device specifications for a particular version (i.e. FS6206-xx) are guaranteed only with the operating voltage and reference frequency specified in Version Information.

FS6206

Dual-PLL Clock Generator IC



April 2000

4.0 Package Information

Table 5: 8-pin SOIC (0.150") Package Dimensions

	DIMENSIONS			
	INCHES		MILLIMETERS	
	MIN.	MAX.	MIN.	MAX.
A	0.061	0.068	1.55	1.73
A1	0.004	0.0098	0.102	0.249
A2	0.055	0.061	1.40	1.55
B	0.013	0.019	0.33	0.49
C	0.0075	0.0098	0.191	0.249
D	0.189	0.196	4.80	4.98
E	0.150	0.157	3.81	3.99
e	0.050 BSC		1.27 BSC	
H	0.230	0.244	5.84	6.20
h	0.010	0.016	0.25	0.41
L	0.016	0.035	0.41	0.89
Θ	0°	8°	0°	8°

Table 6: 8-pin SOIC (0.150") Package Characteristics

PARAMETER	SYMBOL	CONDITIONS/DESCRIPTION	TYP.	UNITS
Thermal Impedance, Junction to Free-Air 8-pin 0.150" SOIC	Θ_{JA}	Air flow = 0 m/s	110	°C/W
Lead Inductance, Self	L_{11}	Corner lead	2.0	nH
		Center lead	1.6	
Lead Inductance, Mutual	L_{12}	Any lead to any adjacent lead	0.4	nH
Lead Capacitance, Bulk	C_{11}	Any lead to V_{SS}	0.27	pF

April 2000

5.0 Ordering Information

Table 7: Device Ordering Codes

ORDERING CODE	DEVICE NUMBER	PACKAGE TYPE	OPERATING TEMPERATURE RANGE	SHIPPING CONFIGURATION
11640-824	FS6206-01	8-pin (0.150") SOIC (Small Outline Package)	0° C to 70° C (Commercial)	Tape and Reel
11640-834	FS6206-01	8-pin (0.150") SOIC (Small Outline Package)	0° C to 70° C (Commercial)	Tubes

6.0 Revision Information

DATE	PAGE	DESCRIPTION
4/24/00	5	Added ordering code information
4/24/00	1, 2	Fixed formatting errors

Copyright © 1999, 2000 American Microsystems, Inc.

Devices sold by AMI are covered by the warranty and patent indemnification provisions appearing in its Terms of Sale only. AMI makes no warranty, express, statutory implied or by description, regarding the information set forth herein or regarding the freedom of the described devices from patent infringement. AMI makes no warranty of merchantability or fitness for any purposes. AMI reserves the right to discontinue production and change specifications and prices at any time and without notice. AMI's products are intended for use in commercial applications. Applications requiring extended temperature range, unusual environmental requirements, or high reliability applications, such as military, medical life-support or life-sustaining equipment, are specifically not recommended without additional processing by AMI for such applications.

American Microsystems, Inc., 2300 Buckskin Rd., Pocatello, ID 83201, (208) 233-4690, FAX (208) 234-6796, WWW Address: <http://www.amis.com> E-mail: tgp@amis.com