

# Synchronous DRAM

## MT48LC2M32B2 – 512K x 32 x 4 banks

For the latest data sheet, refer to Micron's Web site

### Features

- PC100 functionality
- Fully synchronous; all signals registered on positive edge of system clock
- Internal pipelined operation; column address can be changed every clock cycle
- Internal banks for hiding row access/precharge
- Programmable burst lengths: 1, 2, 4, 8, or full page
- Auto precharge, includes concurrent auto precharge, and auto refresh modes
- Self refresh mode
- 64ms, 4,096-cycle refresh (15.6µs/row)
- LVTTL-compatible inputs and outputs
- Single +3.3V ±0.3V power supply
- Supports CAS latency (CL) of 1, 2, and 3

### Options

- Configuration
  - 2 Meg x 32 (512K x 32 x 4 banks)
- Plastic package – OCPL<sup>1</sup>
  - 86-pin TSOP II (400 mil)
  - 86-pin TSOP II (400 mil) Pb-free
  - 90-ball VFBGA (8mm x 13mm) lead-free
- Timing (cycle time)
  - 5ns (200 MHz)
  - 5.5ns (183 MHz)
  - 6ns (166 MHz)
  - 7ns (143 MHz)
- Die revision
- Operating temperature range
  - Commercial (0° to +70°C)
  - Extended (-40°C to +85°C)

### Marking

2M32B2  
TG  
P  
B5  
-5  
-55  
-6  
-7  
:G  
None  
IT<sup>2</sup>

- Notes: 1. Off-center parting line.  
2. Available on -6 and -7.

*Part Number Example:*  
**MT48LC2M32B2P-7:G**

**Table 1: Address Table**

	<b>2 Meg x 32</b>
Configuration	512K x 32 x 4 banks
Refresh count	4K
Row addressing	2K (A0–A10)
Bank addressing	4 (BA0, BA1)
Column addressing	256 (A0–A7)

**Table 2: Key Timing Parameters**

CL = CAS (READ) latency

Speed Grade	Clock Frequency	Access Time	Setup Time	Hold Time
		CL = 3		
-5	200 MHz	4.5ns	1.5ns	1ns
-55	183 MHz	5ns	1.5ns	1ns
-6	166 MHz	5.5ns	1.5ns	1ns
-7	143 MHz	5.5ns	2ns	1ns

**Table 3: 64Mb (x32) SDRAM Part Number**

Part Number	Architecture
MT48LC2M32B2TG	2 Meg x 32
MT48LC2M32B2P	2 Meg x 32
MT48LC2M32B2B5 <sup>1</sup>	2 Meg x 32

Notes: 1. FBGA Device Decode: <http://www.micron.com/support/FBGA/FBGA.asp>

## General Description

The Micron<sup>®</sup> 64Mb SDRAM is a high-speed CMOS, dynamic random-access memory containing 67,108,864 bits. It is internally configured as a quad-bank DRAM with a synchronous interface (all signals are registered on the positive edge of the clock signal, CLK). Each of the 16,777,216-bit banks is organized as 2,048 rows by 256 columns by 32 bits.

Read and write accesses to the SDRAM are burst oriented; accesses start at a selected location and continue for a programmed number of locations in a programmed sequence. Accesses begin with the registration of an ACTIVE command, which is then followed by a READ or WRITE command. The address bits registered coincident with the ACTIVE command are used to select the bank and row to be accessed (BA0, BA1 select the bank, A0–A10 select the row). The address bits registered coincident with the READ or WRITE command are used to select the starting column location for the burst access.

The SDRAM provides for programmable read or write burst lengths (BL) of 1, 2, 4, or 8 locations, or the full page, with a burst terminate option. An auto precharge function may be enabled to provide a self-timed row precharge that is initiated at the end of the burst sequence.

The 64Mb SDRAM uses an internal pipelined architecture to achieve high-speed operation. This architecture is compatible with the  $2n$  rule of prefetch architectures, but it also allows the column address to be changed on every clock cycle to achieve a high-speed, fully random access. Precharging one bank while accessing one of the other three banks will hide the PRECHARGE cycles and provide seamless, high-speed, random-access operation.

The 64Mb SDRAM is designed to operate in 3.3V, low-power memory systems. An auto refresh mode is provided, along with a power-saving, power-down mode. All inputs and outputs are LVTTTL-compatible.

SDRAMs offer substantial advances in DRAM operating performance, including the ability to synchronously burst data at a high data rate with automatic column-address generation, the ability to interleave between internal banks to hide precharge time and the capability to randomly change column addresses on each clock cycle during a burst access.

## Table of Contents

Features . . . . .	1
Options . . . . .	1
General Description . . . . .	2
Functional Block Diagram . . . . .	6
Pin/Ball Assignments and Descriptions . . . . .	7
Functional Description . . . . .	10
Initialization . . . . .	10
Register Definition . . . . .	12
Mode Register . . . . .	12
Burst Length . . . . .	12
Burst Type . . . . .	13
CAS Latency . . . . .	14
Operating Mode . . . . .	16
Write Burst Mode . . . . .	16
Commands . . . . .	16
COMMAND INHIBIT . . . . .	17
NO OPERATION (NOP) . . . . .	17
LOAD MODE REGISTER . . . . .	17
ACTIVE . . . . .	17
READ . . . . .	17
WRITE . . . . .	17
PRECHARGE . . . . .	18
Auto Precharge . . . . .	18
BURST TERMINATE . . . . .	18
AUTO REFRESH . . . . .	18
SELF REFRESH . . . . .	18
Operations . . . . .	19
Bank/Row Activation . . . . .	19
READs . . . . .	20
WRITEs . . . . .	29
PRECHARGE . . . . .	32
Power-Down . . . . .	33
Clock Suspend . . . . .	34
Burst Read/Single Write . . . . .	35
Concurrent Auto Precharge . . . . .	36
Electrical Specifications . . . . .	43
Temperature and Thermal Impedance . . . . .	43
Notes . . . . .	49
Timing Diagrams . . . . .	51
Package Dimensions . . . . .	68

## List of Figures

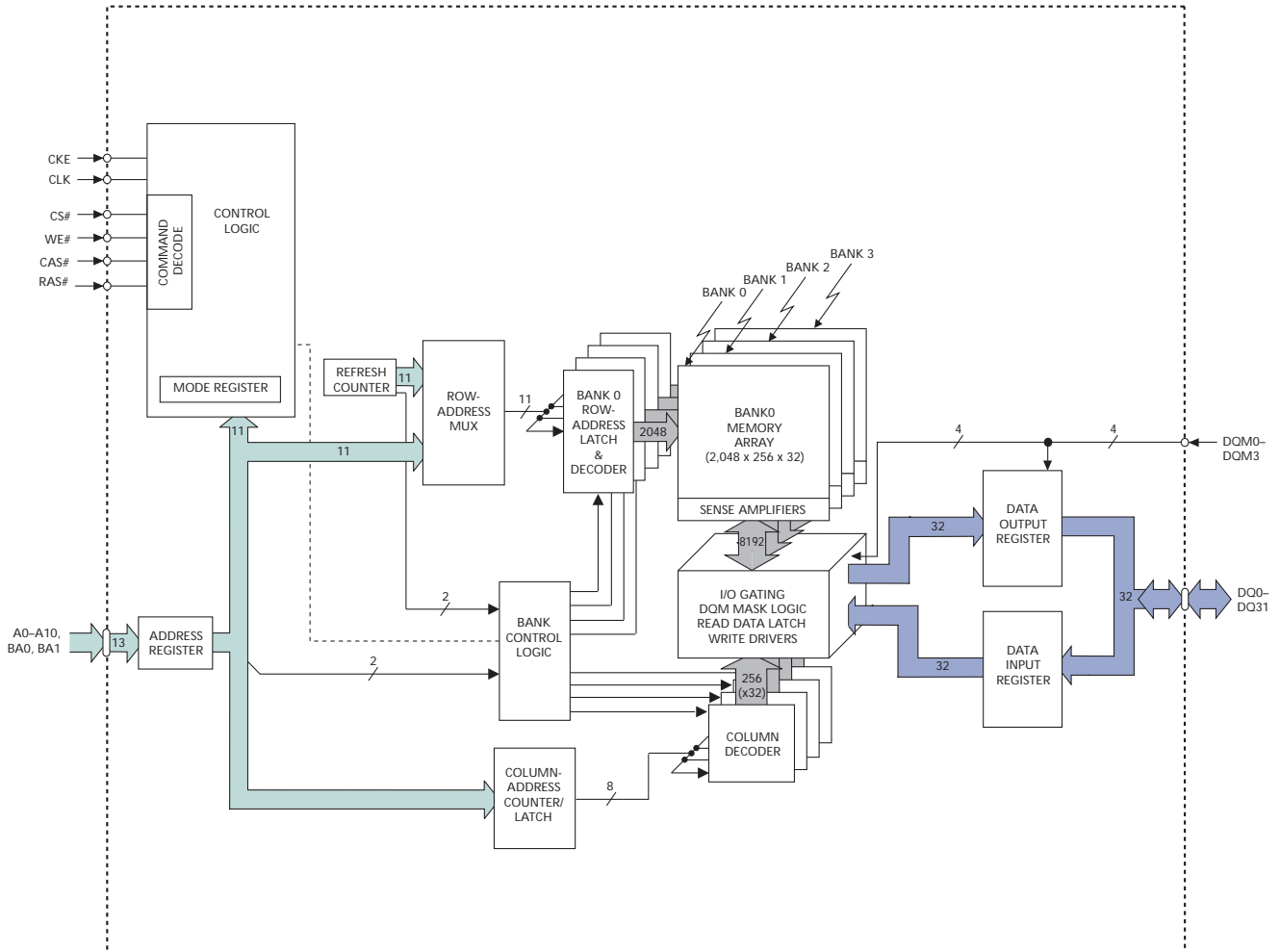
Figure 1:	2 Meg x 32 SDRAM	6
Figure 2:	86-Pin TSOP (Top View)	7
Figure 3:	90-Ball VFBGA (Top View, Ball Down)	8
Figure 4:	Mode Register Definition	13
Figure 5:	CAS Latency	15
Figure 6:	Activating a Specific Row in a Specific Bank	20
Figure 7:	Example: Meeting $t_{RCD}(\text{MIN})$ when $2 < t_{RCD}(\text{MIN})/t_{CK} - 3$	20
Figure 8:	READ Command	21
Figure 9:	CAS Latency	22
Figure 10:	Consecutive READ Bursts	23
Figure 11:	Random READ Accesses	24
Figure 12:	READ-to-WRITE	25
Figure 13:	READ-to-WRITE With Extra Clock Cycle	26
Figure 14:	READ-to-PRECHARGE	27
Figure 15:	Terminating a READ Burst	28
Figure 16:	WRITE Command	29
Figure 17:	WRITE Burst	30
Figure 18:	WRITE-to-WRITE	30
Figure 19:	Random WRITE Cycles	31
Figure 20:	WRITE-to-READ	31
Figure 21:	WRITE-to-PRECHARGE	32
Figure 22:	Terminating a WRITE Burst	33
Figure 23:	PRECHARGE Command	34
Figure 24:	Power-Down	34
Figure 25:	Clock Suspend During WRITE Burst	35
Figure 26:	Clock Suspend During READ Burst	35
Figure 27:	READ with Auto Precharge Interrupted by a READ	36
Figure 28:	READ with Auto Precharge Interrupted by a WRITE	37
Figure 29:	WRITE with Auto Precharge Interrupted by a READ	37
Figure 30:	WRITE with Auto Precharge Interrupted by a WRITE	38
Figure 31:	Example Temperature Test Point Location, 86-Pin TSOP (Top View)	45
Figure 32:	Example Temperature Test Point Location, 90-Ball FBGA (Top View)	45
Figure 33:	Initialize and Load Mode Register	51
Figure 34:	Power-Down Mode	52
Figure 35:	Clock Suspend Mode	53
Figure 36:	Auto Refresh Mode	54
Figure 37:	Self Refresh Mode	55
Figure 38:	Single READ	56
Figure 39:	Single READ – Without Auto Precharge	57
Figure 40:	READ – with Auto Precharge	58
Figure 41:	Alternating Bank Read Accesses	59
Figure 42:	READ – Full-Page Burst	60
Figure 43:	READ – DQM Operation	61
Figure 44:	Single WRITE	62
Figure 45:	WRITE – Without Auto Precharge	63
Figure 46:	WRITE – with Auto Precharge	64
Figure 47:	Alternating Write Accesses	65
Figure 48:	WRITE – Full-Page Burst	66
Figure 49:	WRITE – DQM Operation	67
Figure 50:	86-Pin Plastic TSOP II (400 mil)	68
Figure 51:	90-Ball VFBGA (8mm x 13mm)	69

## List of Tables

Table 1:	Address Table	1
Table 2:	Key Timing Parameters	1
Table 3:	64Mb (x32) SDRAM Part Number	1
Table 4:	Pin/Ball Descriptions	9
Table 5:	Burst Definition	14
Table 6:	CAS Latency	15
Table 7:	Truth Table 1 – Commands and DQM Operation	16
Table 8:	Truth Table 2 – CKE	38
Table 9:	Truth Table 3 – Current State Bank n, Command to Bank n	39
Table 10:	Truth Table 4 – Current State Bank n, Command to Bank m	41
Table 11:	Absolute Maximum Ratings	43
Table 12:	Temperature Limits	44
Table 13:	Thermal Impedance Simulated Values	44
Table 14:	DC Electrical Characteristics and Operating Conditions	46
Table 15:	IDD Specifications and Conditions	46
Table 16:	TSOP Capacitance	47
Table 17:	VFBGA Capacitance	47
Table 18:	Electrical Characteristics and Recommended AC Operating Conditions	47
Table 19:	AC Functional Characteristics	48

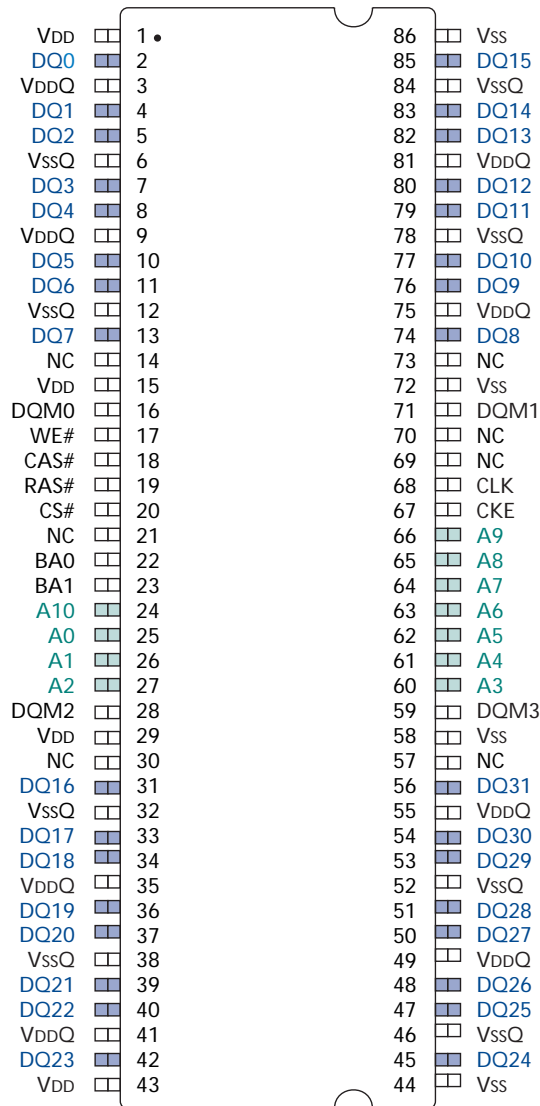
## Functional Block Diagram

Figure 1: 2 Meg x 32 SDRAM



## Pin/Ball Assignments and Descriptions

Figure 2: 86-Pin TSOP (Top View)



Note: The # symbol indicates signal is active LOW.

Figure 3: 90-Ball VFBGA (Top View, Ball Down)

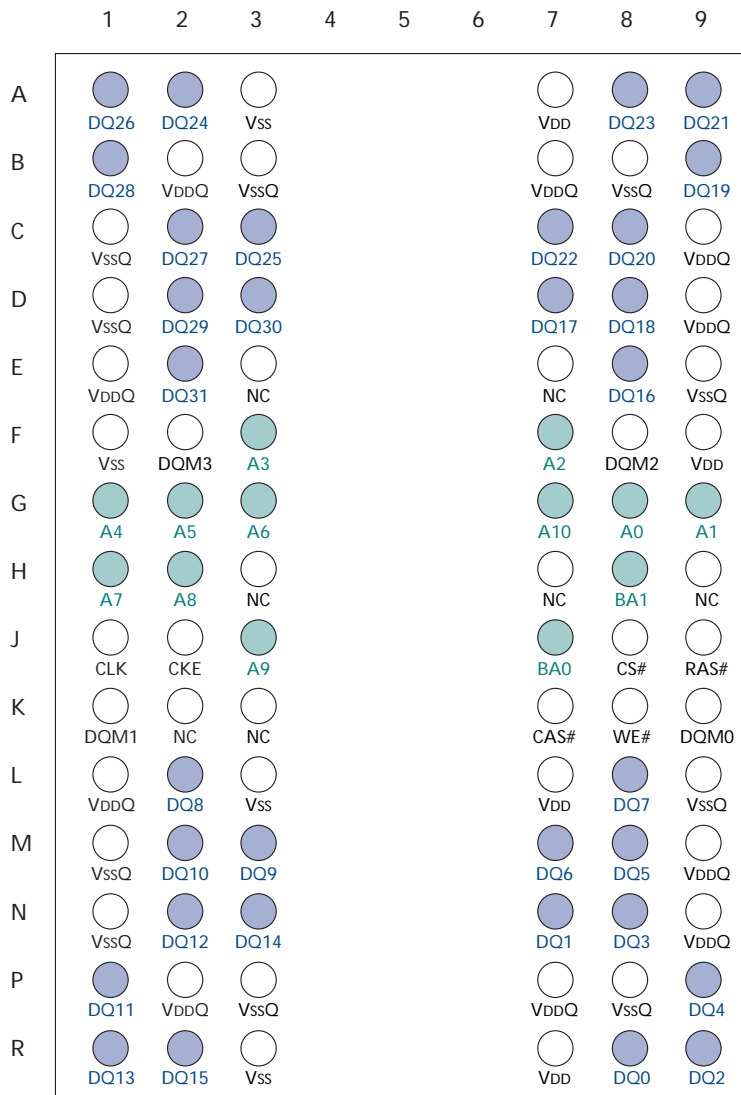




Table 4: Pin/Ball Descriptions

86-Pin TSOP Numbers	90-Ball VFBGA Numbers	Symbol	Type	Description
68	J1	CLK	Input	<b>Clock:</b> CLK is driven by the system clock. All SDRAM input signals are sampled on the positive edge of CLK. CLK also increments the internal burst counter and controls the output registers.
67	J2	CKE	Input	<b>Clock enable:</b> CKE activates (HIGH) and deactivates (LOW) the CLK signal. Deactivating the clock provides PRECHARGE power-down and SELF REFRESH operation (all banks idle), ACTIVE power-down (row active in any bank), or CLOCK SUSPEND operation (burst/access in progress). CKE is synchronous except after the device enters power-down and self refresh modes, where CKE becomes asynchronous until after exiting the same mode. The input buffers, including CLK, are disabled during power-down and self refresh modes, providing low standby power. CKE may be tied HIGH.
20	J8	CS#	Input	<b>Chip select:</b> CS# enables (registered LOW) and disables (registered HIGH) the command decoder. All commands are masked when CS# is registered HIGH, but READ/WRITE bursts already in progress will continue and DQM operation will retain its DQ mask capability while CS# is HIGH. CS# provides for external bank selection on systems with multiple banks. CS# is considered part of the command code.
17, 18, 19	K8, K7, J9	WE#, CAS#, RAS#	Input	<b>Command inputs:</b> WE#, CAS#, and RAS# (along with CS#) define the command being entered.
16, 71, 28, 59	K9, K1, F8, F2	DQM0–DQM3	Input	<b>Input/output mask:</b> DQM is sampled HIGH and is an input mask signal for write accesses and an output enable signal for read accesses. Input data is masked during a WRITE cycle. The output buffers are placed in a High-Z state (2-clock latency) during a READ cycle. DQM0 corresponds to DQ0–DQ7; DQM1 corresponds to DQ8–DQ15; DQM2 corresponds to DQ16–DQ23; and DQM3 corresponds to DQ24–DQ31. DQM0–DQM3 are considered same state when referenced as DQM.
22, 23	J7, H8	BA0, BA1	Input	<b>Bank address input(s):</b> BA0 and BA1 define to which bank the ACTIVE, READ, WRITE, or PRECHARGE command is being applied.
25–27, 60–66, 24	G8, G9, F7, F3, G1, G2, G3, H1, H2, J3, G7	A0–A10	Input	<b>Address inputs:</b> A0–A10 are sampled during the ACTIVE command (row-address A0–A10) and READ/WRITE command (column-address A0–A7 with A10 defining auto precharge) to select one location out of the memory array in the respective bank. A10 is sampled during a PRECHARGE command to determine whether all banks are to be precharged (A10 HIGH) or bank selected by BA0, BA1 (LOW). The address inputs also provide the op-code during a LOAD MODE REGISTER command.
2, 4, 5, 7, 8, 10, 11, 13, 74, 76, 77, 79, 80, 82, 83, 85, 31, 33, 34, 36, 37, 39, 40, 42, 45, 47, 48, 50, 51, 53, 54, 56	R8, N7, R9, N8, P9, M8, M7, L8, L2, M3, M2, P1, N2, R1, N3, R2, E8, D7, D8, B9, C8, A9, C7, A8, A2, C3, A1, C2, B1, D2, D3, E2	DQ0–DQ31	Input/Output	<b>Data I/Os:</b> Data bus.

**Table 4: Pin/Ball Descriptions (continued)**

86-Pin TSOP Numbers	90-Ball VFBGA Numbers	Symbol	Type	Description
3, 9, 35, 41, 49, 55, 75, 81	B2, B7, C9, D9, E1, L1, M9, N9, P2, P7	VDDQ	Supply	<b>DQ power supply:</b> Isolated on the die for improved noise immunity.
6, 12, 32, 38, 46, 52, 78, 84	B8, B3, C1, D1, E9, L9, M1, N1, P3, P8	VssQ	Supply	<b>DQ ground:</b> Provide isolated ground to DQs for improved noise immunity.
1, 15, 29, 43	A7, F9, L7, R7	VDD	Supply	<b>Power supply:</b> +3.3V ±0.3V. (See note 27 on page 50.)
44, 58, 72, 86	A3, F1, L3, R3	Vss	Supply	<b>Ground.</b>
14, 21, 30, 57, 69, 70, 73	E3, E7, H3, H7, K2, K3, H9	NC	–	<b>No connect:</b> These pins/balls should be left unconnected. Pin 70 is reserved for SSTL reference voltage supply. H7 is a no connect for this part but may be used as A12 in future designs. H9 is used as A11 in 128Mb, 256Mb, and 512Mb x32 FBGAs. PCB designs that accommodate different densities must account for A11 with stuffing options.

## Functional Description

In general, this 64Mb SDRAM (512K x 32 x 4 banks) is a 4-bank DRAM that operates at 3.3V and includes a synchronous interface (all signals are registered on the positive edge of the clock signal, CLK). Each of the 16,777,216-bit banks is organized as 2,048 rows by 256 columns by 32 bits.

Read and write accesses to the SDRAM are burst oriented; accesses start at a selected location and continue for a programmed number of locations in a programmed sequence. Accesses begin with the registration of an ACTIVE command, which is then followed by a READ or WRITE command. The address bits registered coincident with the ACTIVE command are used to select the bank and row to be accessed (BA0 and BA1 select the bank, A0–A10 select the row). The address bits (A0–A7) registered coincident with the READ or WRITE command are used to select the starting column location for the burst access.

Prior to normal operation, the SDRAM must be initialized. The following sections provide detailed information covering device initialization, register definition, command descriptions, and device operation.

## Initialization

SDRAMs must be powered up and initialized in a predefined manner. Operational procedures other than those specified may result in undefined operation. After power is applied to VDD and VDDQ (simultaneously) and the clock is stable (stable clock is defined as a signal cycling within timing constraints specified for the clock pin), the SDRAM requires a 100µs delay prior to issuing any command other than a COMMAND INHIBIT or NOP. Starting at some point during this 100µs period, and continuing at least through the end of this period, COMMAND INHIBIT or NOP commands must be applied.

When the 100µs delay has been satisfied with at least one COMMAND INHIBIT or NOP command having been applied, a PRECHARGE command should be applied. All banks must then be precharged, thereby placing the device in the all banks idle state.

When in the idle state, at least two AUTO REFRESH cycles must be performed. After the AUTO REFRESH cycles are complete, the SDRAM is ready for mode register programming. Because the mode register will power up in an unknown state, it must be loaded prior to applying any operational command. If desired, the two AUTO REFRESH commands can be issued after the LOAD MODE REGISTER command.

The recommended power-up sequence for SDRAMs:

1. Simultaneously apply power to VDD and VDDQ.
2. Assert and hold CKE at a LVTTTL logic LOW since all inputs and outputs are LVTTTL-compatible.
3. Provide stable CLOCK signal. Stable clock is defined as a signal cycling within timing constraints specified for the clock pin.
4. Wait at least 100 $\mu$ s prior to issuing any command other than a COMMAND INHIBIT or NOP.
5. Starting at some point during this 100 $\mu$ s period, bring CKE HIGH. Continuing at least through the end of this period, 1 or more COMMAND INHIBIT or NOP commands must be applied.
6. Perform a PRECHARGE ALL command.
7. Wait at least  $t_{RP}$  time; during this time, 0 NOPS or DESELECT commands must be given. All banks will complete their precharge, thereby placing the device in the all banks idle state.
8. Issue an AUTO REFRESH command.
9. Wait at least  $t_{RFC}$  time, during which only NOPS or COMMAND INHIBIT commands are allowed.
10. Issue an AUTO REFRESH command.
11. Wait at least  $t_{RFC}$  time, during which only NOPS or COMMAND INHIBIT commands are allowed.
12. The SDRAM is now ready for mode register programming. Because the mode register will power up in an unknown state, it should be loaded with desired bit values prior to applying any operational command. Using the LMR command, program the mode register. The mode register is programmed via the MODE REGISTER SET command with BA1 = 0, BA0 = 0 and retains the stored information until it is programmed again or the device loses power. Not programming the mode register upon initialization will result in default settings which may not be desired. Outputs are guaranteed High-Z after the LMR command is issued. Outputs should be High-Z already before the LMR command is issued.
13. Wait at least  $t_{MRD}$  time, during which only NOP or DESELECT commands are allowed.

At this point the DRAM is ready for any valid command.

**Note:** If desired, more than two AUTO REFRESH commands can be issued in the sequence. After steps 9 and 10 are complete, repeat them until the desired number of AUTO REFRESH +  $t_{RFC}$  loops is achieved.

## Register Definition

### Mode Register

The mode register is used to define the specific mode of operation of the SDRAM. This definition includes the selection of a burst length, a burst type, a CL, an operating mode and a write burst mode, as shown in Figure 4 on page 13. The mode register is programmed via the LOAD MODE REGISTER command and will retain the stored information until it is programmed again or the device loses power.

Mode register bits M0–M2 specify the burst length, M3 specifies the type of burst (sequential or interleaved), M4–M6 specify the CL, M7, and M8 specify the operating mode, M9 specifies the write burst mode, and M10 is reserved for future use.

The mode register must be loaded when all banks are idle, and the controller must wait the specified time before initiating the subsequent operation. Violating either of these requirements will result in unspecified operation.

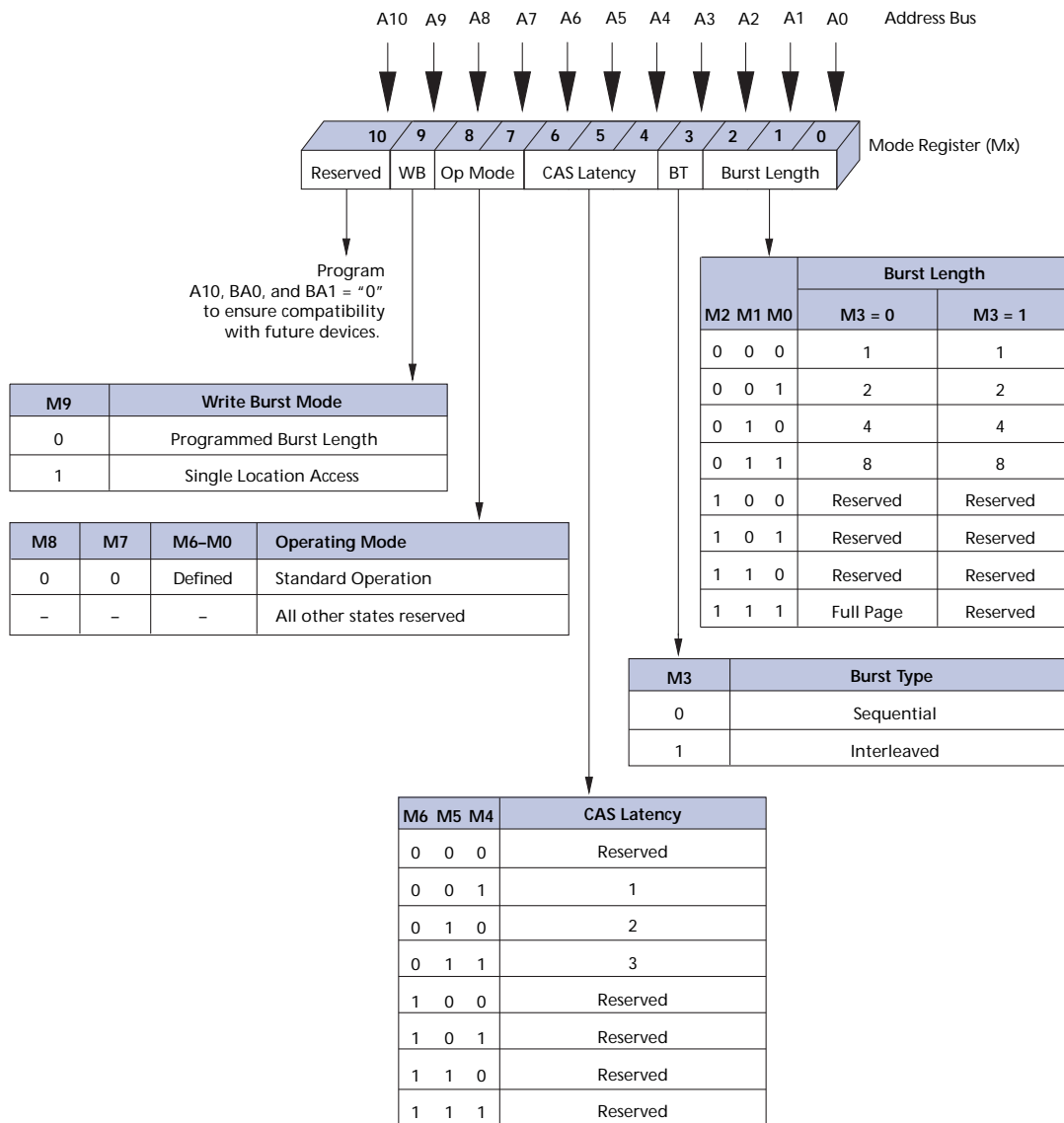
### Burst Length

Read and write accesses to the SDRAM are burst oriented, with the burst length being programmable, as shown in Figure 4. The burst length determines the maximum number of column locations that can be accessed for a given READ or WRITE command. Burst lengths of 1, 2, 4, or 8 locations are available for both the sequential and the interleaved burst types, and a full-page burst is available for the sequential type. The full-page burst is used in conjunction with the BURST TERMINATE command to generate arbitrary burst lengths.

Reserved states should not be used, as unknown operation or incompatibility with future versions may result.

When a READ or WRITE command is issued, a block of columns equal to the burst length is effectively selected. All accesses for that burst take place within this block, meaning that the burst will wrap within the block if a boundary is reached. The block is uniquely selected by A1–A7 when BL = 2; by A2–A7 when BL = 4; and by A3–A7 when the BL = 8. The remaining (least significant) address bit(s) is (are) used to select the starting location within the block. Full-page bursts wrap within the page if the boundary is reached.

Figure 4: Mode Register Definition



### Burst Type

Accesses within a given burst may be programmed to be either sequential or interleaved; this is referred to as the burst type and is selected via bit M3.

The ordering of accesses within a burst is determined by the burst length, the burst type, and the starting column address, as shown in Table 5 on page 14.

**Table 5: Burst Definition**

Burst Length	Starting Column Address			Order of Accesses Within a Burst	
				Type = Sequential	Type = Interleaved
2	<b>A0</b>				
	0			0-1	0-1
	1			1-0	1-0
4	<b>A1</b>	<b>A0</b>			
	0	0		0-1-2-3	0-1-2-3
	0	1		1-2-3-0	1-0-3-2
	1	0		2-3-0-1	2-3-0-1
	1	1		3-0-1-2	3-2-1-0
8	<b>A2</b>	<b>A1</b>	<b>A0</b>		
	0	0	0	0-1-2-3-4-5-6-7	0-1-2-3-4-5-6-7
	0	0	1	1-2-3-4-5-6-7-0	1-0-3-2-5-4-7-6
	0	1	0	2-3-4-5-6-7-0-1	2-3-0-1-6-7-4-5
	0	1	1	3-4-5-6-7-0-1-2	3-2-1-0-7-6-5-4
	1	0	0	4-5-6-7-0-1-2-3	4-5-6-7-0-1-2-3
	1	0	1	5-6-7-0-1-2-3-4	5-4-7-6-1-0-3-2
	1	1	0	6-7-0-1-2-3-4-5	6-7-4-5-2-3-0-1
	1	1	1	7-0-1-2-3-4-5-6	7-6-5-4-3-2-1-0
Full page (256)	n = A0–A10 (location 0–256)			Cn, Cn + 1, Cn + 2, Cn + 3, Cn + 4... ...Cn - 1, Cn...	Not supported

- Notes:
1. For BL = 2, A1–A7 select the block-of-two burst; A0 selects the starting column within the block.
  2. For BL = 4, A2–A7 select the block-of-four burst; A0–A1 select the starting column within the block.
  3. For BL = 8, A3–A7 select the block-of-eight burst; A0–A2 select the starting column within the block.
  4. For a full-page burst, the full row is selected and A0–A7 select the starting column.
  5. Whenever a boundary of the block is reached within a given sequence above, the following access wraps within the block.
  6. For BL = 1, A0–A7 select the unique column to be accessed, and mode register bit M3 is ignored.

## CAS Latency

The CAS latency is the delay, in clock cycles, between the registration of a READ command and the availability of the first piece of output data. The latency can be set to 1, 2, or 3 clocks.

If a READ command is registered at clock edge  $n$ , and the latency is  $m$  clocks, the data will be available by clock edge  $n + m$ . The DQs will start driving as a result of the clock edge one cycle earlier ( $n + m - 1$ ), and provided that the relevant access times are met, the data will be valid by clock edge  $n + m$ . For example, assuming that the clock cycle time is such that all relevant access times are met, if a READ command is registered at T0 and the latency is programmed to 2 clocks, the DQs will start driving after T1 and the data will be valid by T2, as shown in Figure 5 on page 15. Table 6 on page 15 indicates the operating frequencies at which each CAS latency setting can be used.

Reserved states should not be used because unknown operation or incompatibility with future versions may result.

Figure 5: CAS Latency

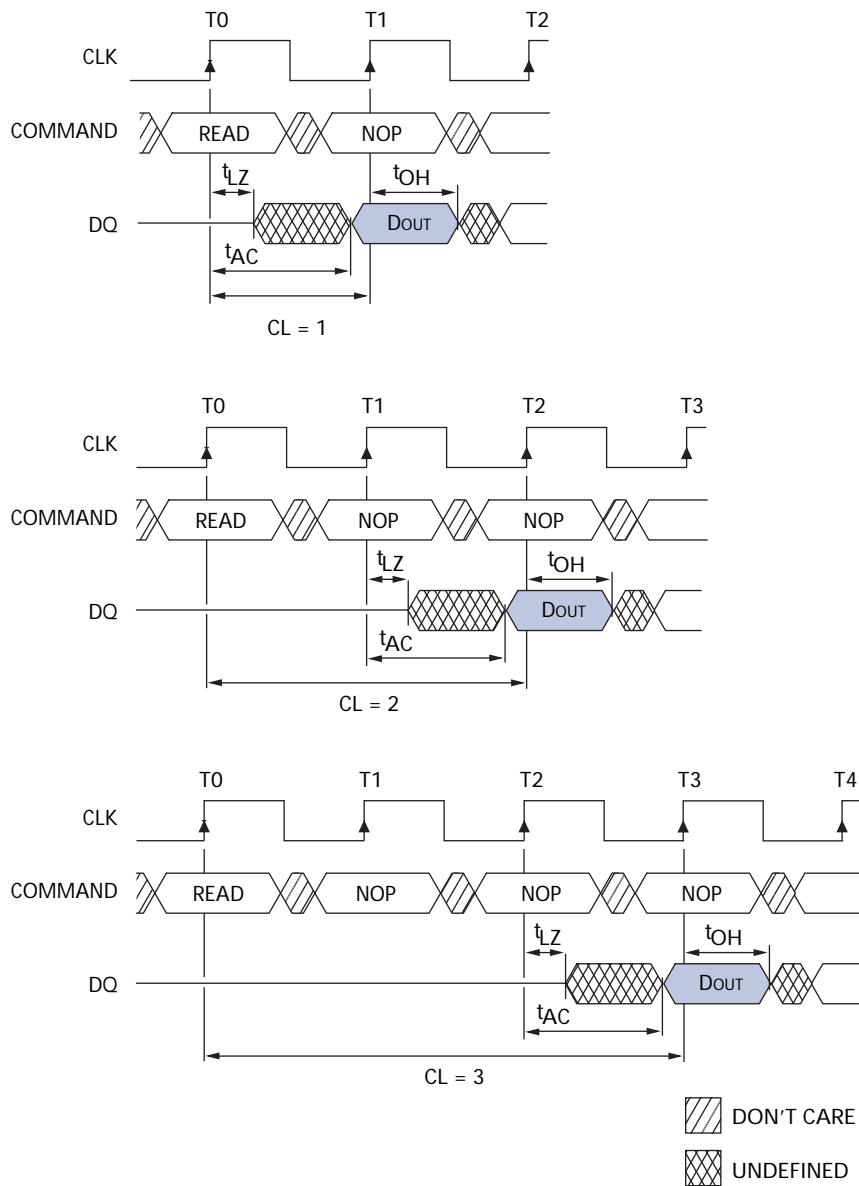


Table 6: CAS Latency

Speed	Allowable Operating Frequency (MHz)		
	CL = 1	CL = 2	CL = 3
-5	-	-	≤ 200
-55	-	-	≤ 183
-6	≤ 50	≤ 100	≤ 166
-7	≤ 50	≤ 100	≤ 143

## Operating Mode

The normal operating mode is selected by setting M7 and M8 to zero; other combinations of values for M7 and M8 are reserved for future use and/or test modes. The programmed burst length applies to both read and write bursts.

Test modes and reserved states should not be used because unknown operation or incompatibility with future versions may result.

## Write Burst Mode

When M9 = 0, the burst length programmed via M0–M2 applies to both read and write bursts; when M9 = 1, the programmed burst length applies to read bursts, but write accesses are single-location (nonburst) accesses.

## Commands

Truth Table 1 provides a quick reference of available commands. This is followed by a written description of each command. Three additional Truth Tables appear following “Operations” on page 19; these tables provide current state/next state information.

**Table 7: Truth Table 1 – Commands and DQM Operation**  
CKE is HIGH for all commands shown except SELF REFRESH

Name (Function)	CS#	RAS#	CAS#	WE#	DQM	ADDR	DQs	Notes
COMMAND INHIBIT (NOP)	H	X	X	X	X	X	X	
NO OPERATION (NOP)	L	H	H	H	X	X	X	
ACTIVE (Select bank and activate row)	L	L	H	H	X	Bank/row	X	1
READ (Select bank and column, and start READ burst)	L	H	L	H	L/H <sup>7</sup>	Bank/col	X	2
WRITE (Select bank and column, and start WRITE burst)	L	H	L	L	L/H <sup>7</sup>	Bank/col	Valid	2
BURST TERMINATE	L	H	H	L	X	X	Active	
PRECHARGE (Deactivate row in bank or banks)	L	L	H	L	X	Code	X	3
AUTO REFRESH or SELF REFRESH (Enter self refresh mode)	L	L	L	H	X	X	X	4, 5
LOAD MODE REGISTER	L	L	L	L	X	Op-code	X	6
WRITE ENABLE/OUTPUT ENABLE	–	–	–	–	L	–	Active	7
WRITE INHIBIT/OUTPUT HIGH-Z	–	–	–	–	H	–	High-Z	7

- Notes:
1. A0–A10 provide row address, BA0 and BA1 determine which bank is made active.
  2. A0–A7 provide column address; A10 HIGH enables the auto precharge feature (nonpersistent), while A10 LOW disables the auto precharge feature; BA0 and BA1 determine which bank is being read from or written to.
  3. A10 LOW: BA0 and BA1 determine the bank being precharged. A10 HIGH: all banks precharged and BA0 and BA1 are “Don’t Care.”
  4. This command is AUTO REFRESH if CKE is HIGH; SELF REFRESH if CKE is LOW.
  5. Internal refresh counter controls row addressing; all inputs and I/Os are “Don’t Care” except for CKE.
  6. A0–A10 define the op-code written to the mode register.
  7. Activates or deactivates the DQs during WRITES (zero-clock delay) and READs (two-clock delay). DQM0 controls DQ0–DQ7; DQM1 controls DQ8–DQ15; DQM2 controls DQ16–DQ23; and DQM3 controls DQ24–DQ31.



## COMMAND INHIBIT

The COMMAND INHIBIT function prevents new commands from being executed by the SDRAM, regardless of whether the CLK signal is enabled. The SDRAM is effectively deselected. Operations already in progress are not affected.

## NO OPERATION (NOP)

The NO OPERATION (NOP) command is used to perform an NOP to an SDRAM that is selected (CS# is LOW). This prevents unwanted commands from being registered during idle or wait states. Operations already in progress are not affected.

## LOAD MODE REGISTER

The mode register is loaded via inputs A0–A10. See “Mode Register” on page 12. The LOAD MODE REGISTER command can only be issued when all banks are idle, and a subsequent executable command cannot be issued until t<sub>MRD</sub> is met.

## ACTIVE

The ACTIVE command is used to open (or activate) a row in a particular bank for a subsequent access. The value on the BA0, BA1 inputs selects the bank, and the address provided on inputs A0–A10 selects the row. This row remains active (or open) for accesses until a PRECHARGE command is issued to that bank. A PRECHARGE command must be issued before opening a different row in the same bank.

## READ

The READ command is used to initiate a burst read access to an active row. The value on the BA0 and BA1 (B1) inputs selects the bank, and the address provided on inputs A0–A7 selects the starting column location. The value on input A10 determines whether auto precharge is used. If auto precharge is selected, the row being accessed will be precharged at the end of the read burst; if auto precharge is not selected, the row will remain open for subsequent accesses. Read data appears on the DQs subject to the logic level on the DQM inputs two clocks earlier. If a given DQM<sub>x</sub> signal was registered HIGH, the corresponding DQs will be High-Z two clocks later; if the DQM<sub>x</sub> signal was registered LOW, the corresponding DQs will provide valid data. DQM0 corresponds to DQ0–DQ7, DQM1 corresponds to DQ8–DQ15, DQM2 corresponds to DQ16–DQ23, and DQM3 corresponds to DQ24–DQ31.

## WRITE

The WRITE command is used to initiate a burst write access to an active row. The value on the BA0 and BA1 inputs selects the bank, and the address provided on inputs A0–A7 selects the starting column location. The value on input A10 determines whether or not auto precharge is used. If auto precharge is selected, the row being accessed will be precharged at the end of the write burst; if auto precharge is not selected, the row will remain open for subsequent accesses. Input data appearing on the DQs is written to the memory array subject to the DQM input logic level appearing coincident with the data. If a given DQM signal is registered LOW, the corresponding data will be written to memory; if the DQM signal is registered HIGH, the corresponding data inputs will be ignored, and a write will not be executed to that byte/column location.

## PRECHARGE

The PRECHARGE command is used to deactivate the open row in a particular bank or the open row in all banks. The bank(s) will be available for a subsequent row access a specified time ( $t_{RP}$ ) after the PRECHARGE command is issued. Input A10 determines whether one or all banks are to be precharged, and in the case where only one bank is to be precharged, inputs BA0 and BA1 select the bank. Otherwise BA0 and BA1 are treated as “Don’t Care.” After a bank has been precharged, it is in the idle state and must be activated prior to any READ or WRITE commands being issued to that bank.

## Auto Precharge

Auto precharge is a feature that performs the same individual-bank precharge function described above, without requiring an explicit command. This is accomplished by using A10 to enable auto precharge in conjunction with a specific READ or WRITE command. A precharge of the bank/row that is addressed with the READ or WRITE command is automatically performed upon completion of the READ or WRITE burst, except in the full-page burst mode, where AUTO PRECHARGE does not apply. Auto precharge is nonpersistent in that it is either enabled or disabled for each READ or WRITE command.

Auto precharge ensures that the precharge is initiated at the earliest valid stage within a burst. The user must not issue another command to the same bank until the precharge time ( $t_{RP}$ ) is completed. This is determined as if an explicit PRECHARGE command was issued at the earliest possible time, as described for each burst type in “Operations” on page 19.

## BURST TERMINATE

The BURST TERMINATE command is used to truncate either fixed-length or full-page bursts. The most recently registered READ or WRITE command prior to the BURST TERMINATE command will be truncated, as shown in “Operations” on page 19. The BURST TERMINATE command does not precharge the row; the row will remain open until a PRECHARGE command is issued.

## AUTO REFRESH

AUTO REFRESH is used during normal operation of the SDRAM and is analogous to CAS#-BEFORE-RAS# (CBR) refresh in conventional DRAMs. This command is nonpersistent, so it must be issued each time a refresh is required.

The addressing is generated by the internal refresh controller. This makes the address bits “Don’t Care” during an AUTO REFRESH command. The 64Mb SDRAM requires 4,096 AUTO REFRESH cycles every 64ms ( $t_{REF}$ ), regardless of width option. Providing a distributed AUTO REFRESH command every 15.625 $\mu$ s will meet the refresh requirement and ensure that each row is refreshed. Alternatively, 4,096 AUTO REFRESH commands can be issued in a burst at the minimum cycle rate ( $t_{RC}$ ), once every 64ms.

## SELF REFRESH

The SELF REFRESH command can be used to retain data in the SDRAM, even if the rest of the system is powered down. When in the self refresh mode, the SDRAM retains data without external clocking. The SELF REFRESH command is initiated like an AUTO REFRESH command except CKE is disabled (LOW). When the SELF REFRESH command is registered, all the inputs to the SDRAM become “Don’t Care” with the exception of CKE, which must remain LOW.

After self refresh mode is engaged, the SDRAM provides its own internal clocking, causing it to perform its own AUTO REFRESH cycles. The SDRAM must remain in self refresh mode for a minimum period equal to  $t_{RAS}$  and may remain in self refresh mode for an indefinite period beyond that.

The procedure for exiting self refresh requires a sequence of commands. First, CLK must be stable (stable clock is defined as a signal cycling within timing constraints specified for the clock pin) prior to CKE going back HIGH. After CKE is HIGH, the SDRAM must have NOP commands issued (a minimum of two clocks) for  $t_{XSR}$  because time is required for the completion of any internal refresh in progress.

Upon exiting self refresh mode, AUTO REFRESH commands must be issued every 15.625 $\mu$ s or less as both SELF REFRESH and AUTO REFRESH utilize the row refresh counter.

## Operations

### Bank/Row Activation

Before any READ or WRITE commands can be issued to a bank within the SDRAM, a row in that bank must be “opened.” This is accomplished via the ACTIVE command, which selects both the bank and the row to be activated. See Figure 6 on page 20.

After opening a row (issuing an ACTIVE command), a READ or WRITE command may be issued to that row, subject to the  $t_{RCD}$  specification.  $t_{RCD}(\text{MIN})$  should be divided by the clock period and rounded up to the next whole number to determine the earliest clock edge after the ACTIVE command on which a READ or WRITE command can be issued. For example, a  $t_{RCD}$  specification of 20ns with a 125 MHz clock (8ns period) results in 2.5 clocks, rounded to 3. This is reflected in Figure 7 on page 20, which covers any case where  $2 < t_{RCD}(\text{MIN})/t_{CK} - 3$  (the same procedure is used to convert other specification limits from time units to clock cycles).

A subsequent ACTIVE command to a different row in the same bank can only be issued after the previous active row has been “closed” (precharged). The minimum time interval between successive ACTIVE commands to the same bank is defined by  $t_{RC}$ .

A subsequent ACTIVE command to another bank can be issued while the first bank is being accessed, which results in a reduction of total row-access overhead. The minimum time interval between successive ACTIVE commands to different banks is defined by  $t_{RRD}$ .

Figure 6: Activating a Specific Row in a Specific Bank

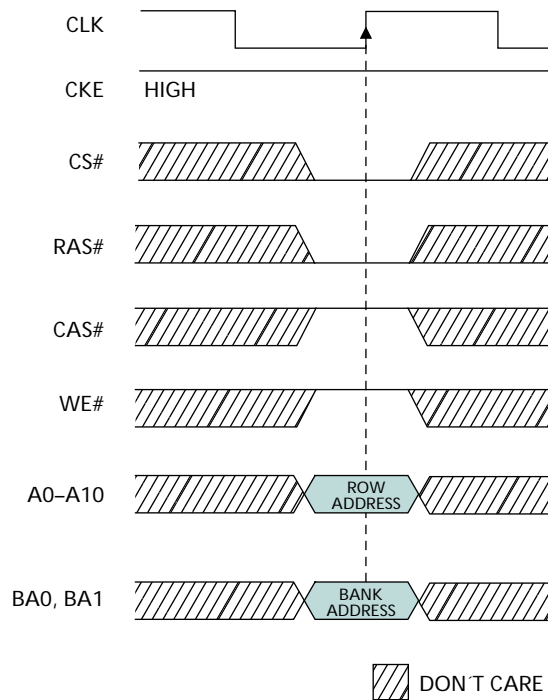
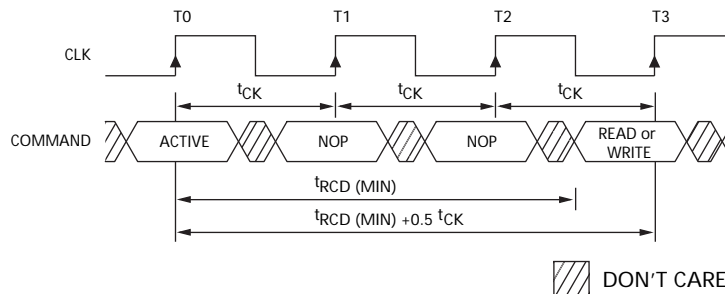


Figure 7: Example: Meeting  $t_{RCD} (MIN)$  when  $2 < t_{RCD} (MIN)/t_{CK} - 3$



- Notes:
1.  $t_{RCD} (MIN) = 20ns$ ,  $t_{CK} = 8ns$ .
  2.  $t_{RCD} (MIN) \times t_{CK}$  where  $x =$  number of clocks for equation to be true.

## READS

READ bursts are initiated with a READ command, as shown in Figure 8 on page 21.

The starting column and bank addresses are provided with the READ command, and auto precharge either is enabled or disabled for that burst access. If auto precharge is enabled, the row being accessed is precharged at the completion of the burst. For the generic READ commands used in the following illustrations, auto precharge is disabled.

During READ bursts, the valid data-out element from the starting column address will be available following the CAS latency after the READ command. Each subsequent data-out element will be valid by the next positive clock edge. Figure 9 on page 22 shows general timing for each possible CAS latency setting.

Upon completion of a burst, assuming no other commands have been initiated, the DQs will go High-Z. A full-page burst will continue until terminated. (At the end of the page, it will wrap to column 0 and continue.)

Data from any READ burst may be truncated with a subsequent READ command, and data from a fixed-length READ burst may be immediately followed by data from a READ command. In either case, a continuous flow of data can be maintained. The first data element from the new burst either follows the last element of a completed burst or the last desired data element of a longer burst that is being truncated. The new READ command should be issued  $x$  cycles before the clock edge at which the last desired data element is valid, where  $x$  equals  $CL - 1$ . This is shown in Figure 10 on page 23 for  $CL = 1$ ,  $CL = 2$ , and  $CL = 3$ ; data element  $n + 3$  is either the last of a burst of four or the last desired of a longer burst. This 64Mb SDRAM uses a pipelined architecture and therefore does not require the  $2n$  rule associated with a prefetch architecture. A READ command can be initiated on any clock cycle following a previous READ command. Full-speed random read accesses can be performed to the same bank, as shown in Figure 11 on page 24, or each subsequent READ may be performed to a different bank.

Figure 8: READ Command

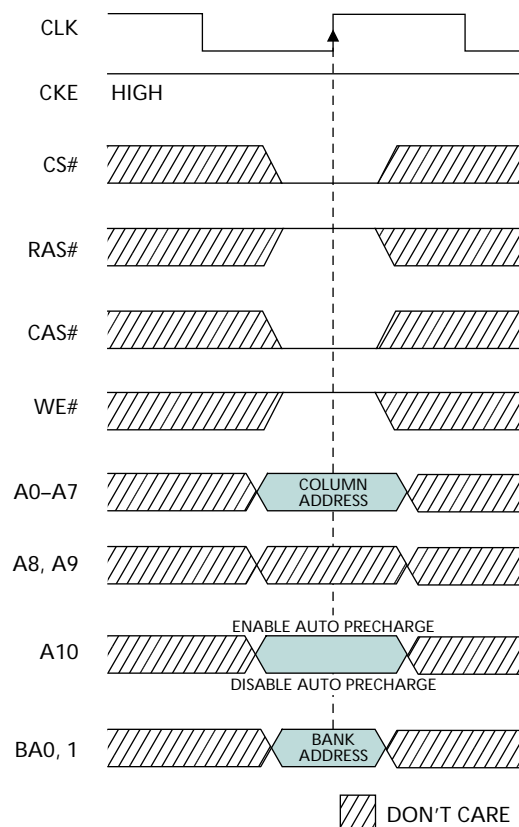


Figure 9: CAS Latency

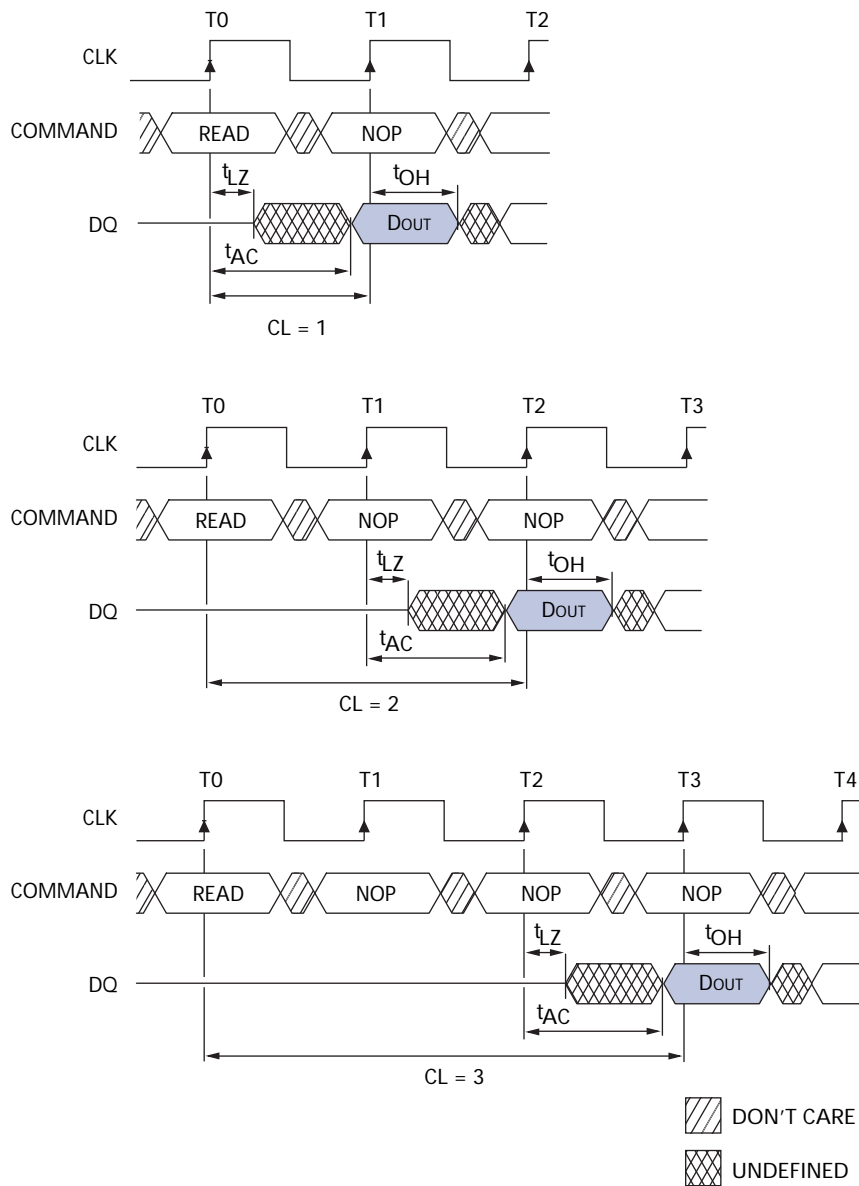
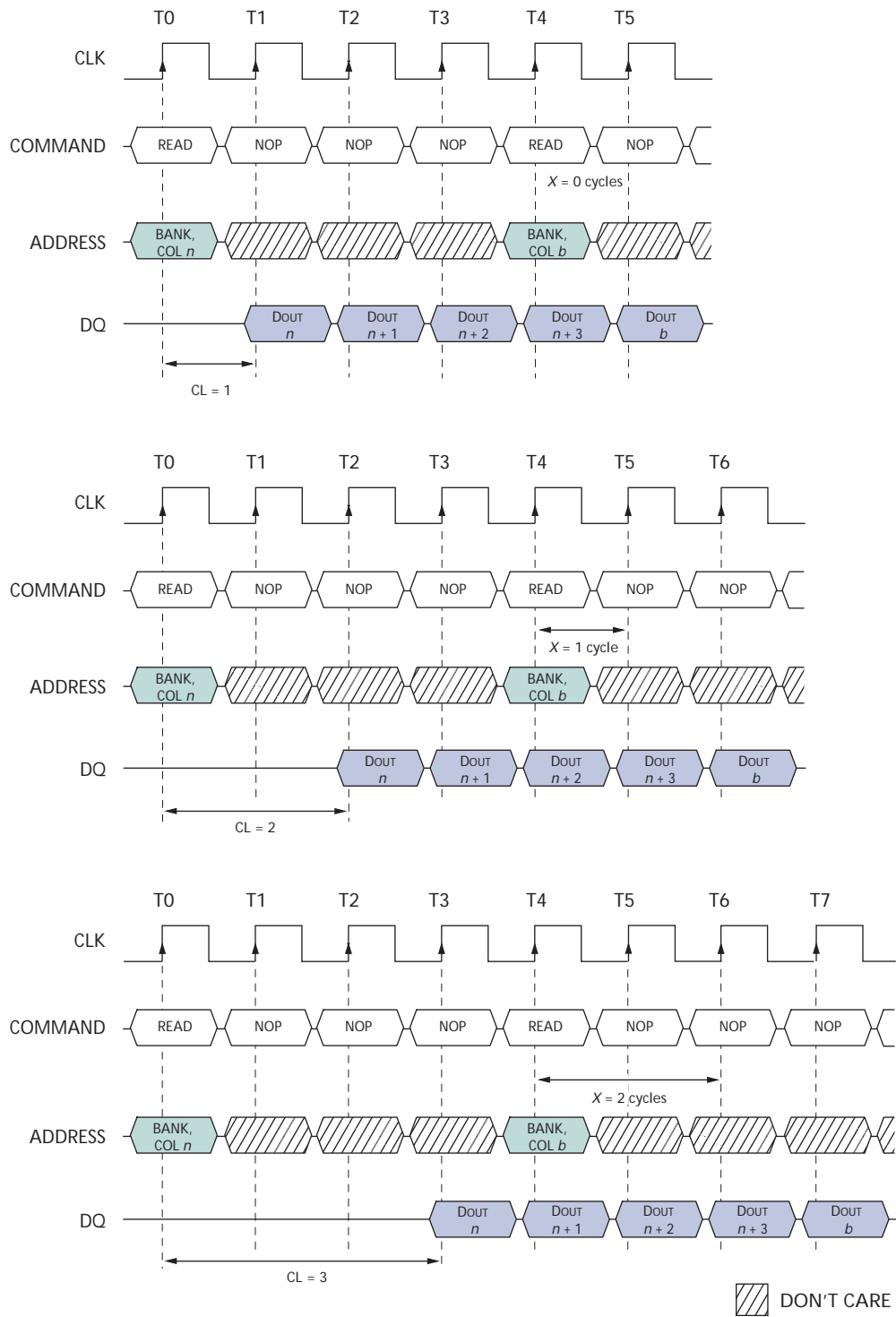
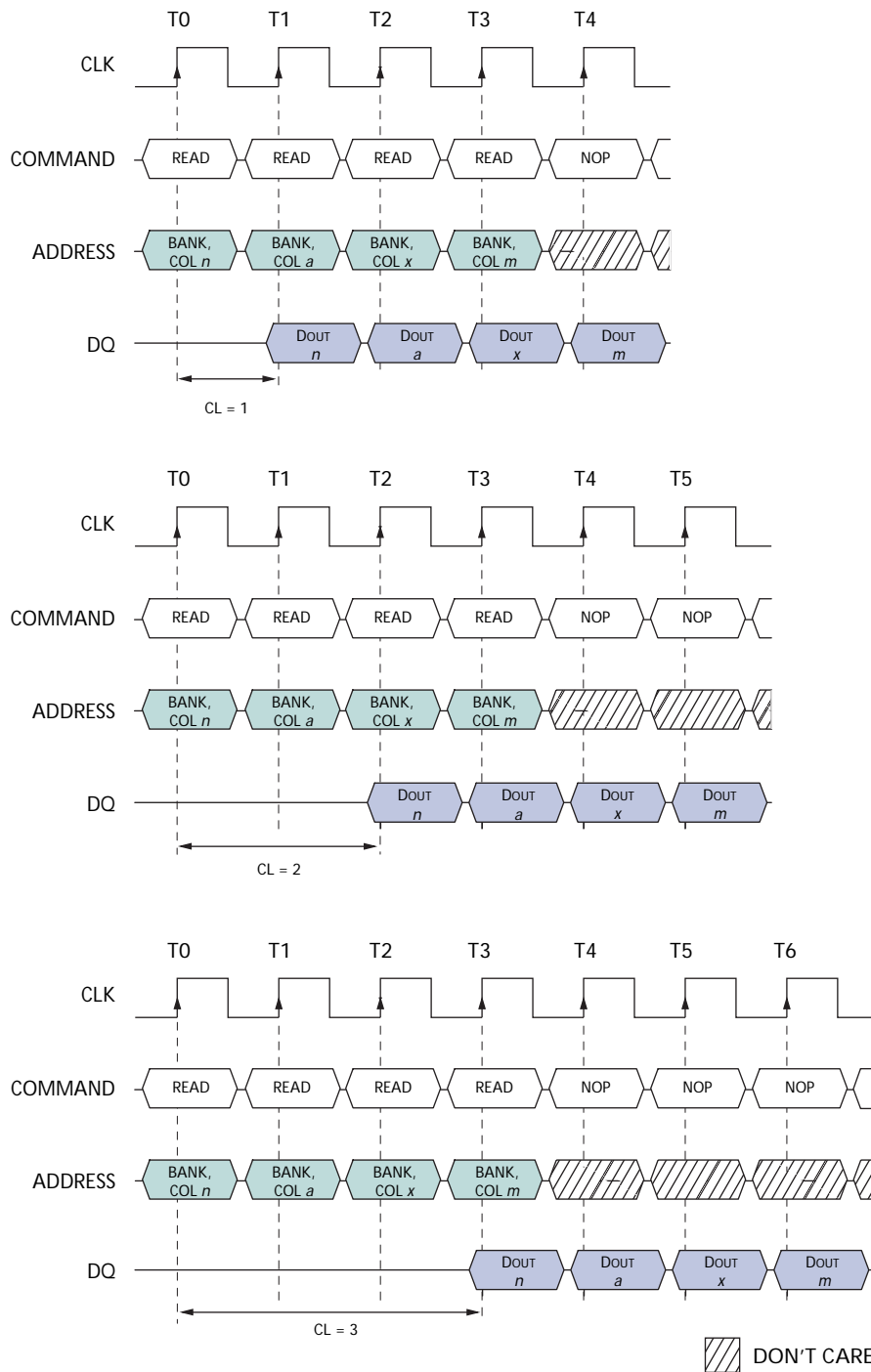


Figure 10: Consecutive READ Bursts



Note: Each READ command may be to any bank. DQM is LOW.

Figure 11: Random READ Accesses



Note: Each READ command may be to any bank. DQM is LOW.

Data from any READ burst may be truncated with a subsequent WRITE command, and data from a fixed-length READ burst may be immediately followed by data from a WRITE command (subject to bus turnaround limitations). The WRITE burst may be initiated on the clock edge immediately following the last (or last desired) data element from the READ burst, provided that I/O contention can be avoided. In a given system

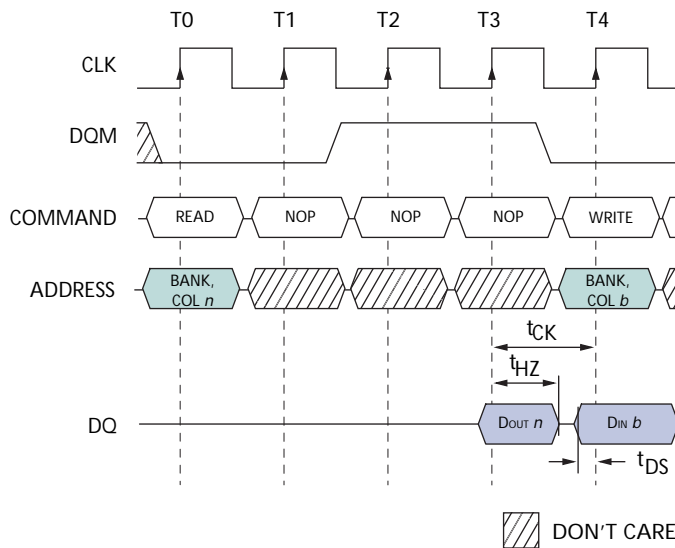


design, there may be a possibility that the device driving the input data will go Low-Z before the SDRAM DQs go High-Z. In this case, at least a single-cycle delay should occur between the last read data and the WRITE command.

The DQM input is used to avoid I/O contention, as shown in Figure 12 and in Figure 13 on page 26. The DQM signal must be asserted (HIGH) at least two clocks prior to the WRITE command (DQM latency is two clocks for output buffers) to suppress data-out from the READ. After the WRITE command is registered, the DQs will go High-Z (or remain High-Z), regardless of the state of the DQM signal; provided the DQM was active on the clock just prior to the WRITE command that truncated the READ command. If not, the second WRITE will be an invalid WRITE. For example, if DQM was LOW during T4 in Figure 13, then the WRITES at T5 and T7 would be valid, while the WRITE at T6 would be invalid.

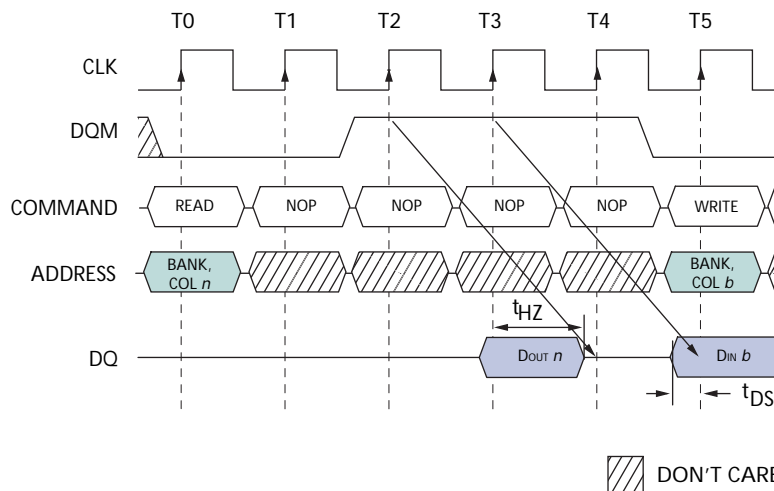
The DQM signal must be de-asserted prior to the WRITE command (DQM latency is zero clocks for input buffers) to ensure that the written data is not masked. Figure 12 shows the case where the clock frequency allows for bus contention to be avoided without adding an NOP cycle, and Figure 13 shows the case where the additional NOP is needed.

Figure 12: READ-to-WRITE



Note: CL = 3 is used for illustration. The READ command may be to any bank, and the WRITE command may be to any bank.

Figure 13: READ-to-WRITE With Extra Clock Cycle

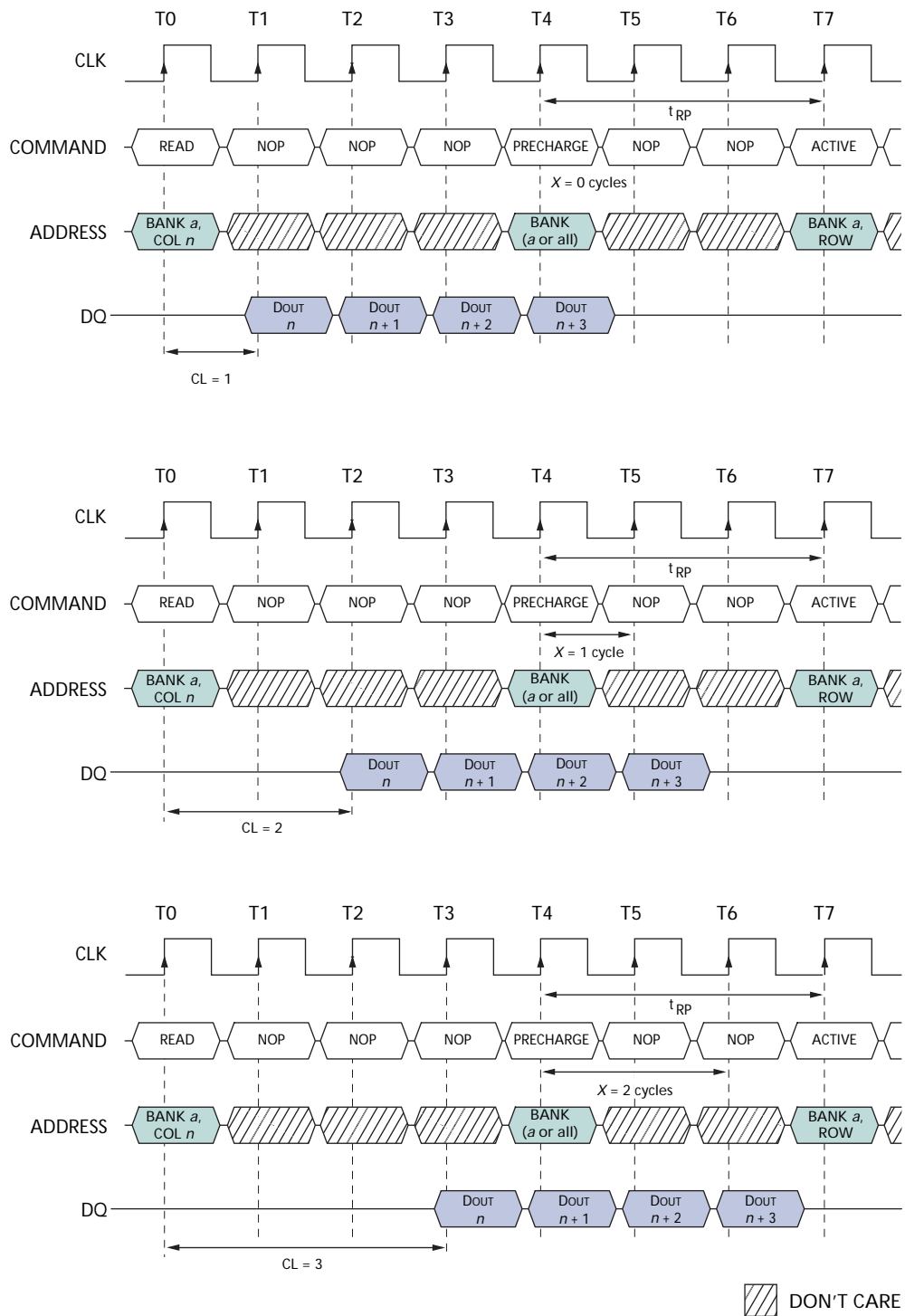


Note: CL = 3 is used for illustration. The READ command may be to any bank, and the WRITE command may be to any bank.

A fixed-length READ burst may be followed by, or truncated with, a PRECHARGE command to the same bank (provided that auto precharge was not activated), and a full-page burst may be truncated with a PRECHARGE command to the same bank. The PRECHARGE command should be issued  $x$  cycles before the clock edge at which the last desired data element is valid, where  $x$  equals  $CL - 1$ . This is shown in Figure 14 on page 27 for each possible CAS latency; data element  $n + 3$  is either the last of a burst of four or the last desired of a longer burst. Following the PRECHARGE command, a subsequent command to the same bank cannot be issued until  $t_{RP}$  is met. Note that part of the row precharge time is hidden during the access of the last data element(s).

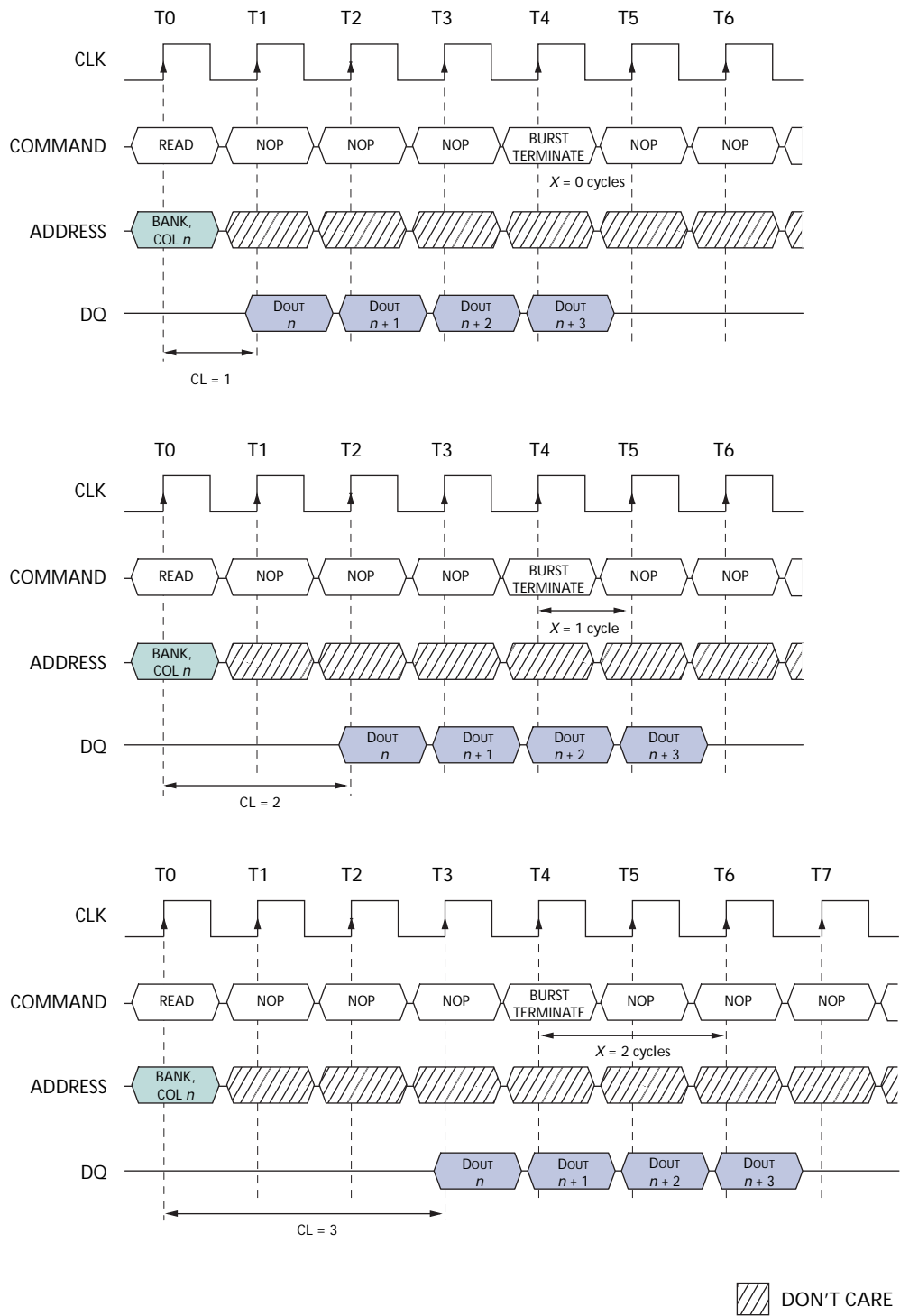
In the case of a fixed-length burst being executed to completion, a PRECHARGE command issued at the optimum time (as described above) provides the same operation that would result from the same fixed-length burst with auto precharge. The disadvantage of the PRECHARGE command is that it requires that the command and address buses be available at the appropriate time to issue the command; the advantage of the PRECHARGE command is that it can be used to truncate fixed-length or full-page bursts.

Full-page READ bursts can be truncated with the BURST TERMINATE command, and fixed-length READ bursts may be truncated with a BURST TERMINATE command, provided that auto precharge was not activated. The BURST TERMINATE command should be issued  $x$  cycles before the clock edge at which the last desired data element is valid, where  $x$  equals  $CL - 1$ . This is shown in Figure 15 on page 28 for each possible CAS latency; data element  $n + 3$  is the last desired data element of a longer burst.

**Figure 14: READ-to-PRECHARGE**


Note: DQM is LOW.

Figure 15: Terminating a READ Burst



Note: DQM is LOW.

## WRITES

WRITE bursts are initiated with a WRITE command, as shown in Figure 16.

The starting column and bank addresses are provided with the WRITE command, and auto precharge is either enabled or disabled for that access. If auto precharge is enabled, the row being accessed is precharged at the completion of the burst. For the generic WRITE commands used in the following illustrations, auto precharge is disabled.

During WRITE bursts, the first valid data-in element will be registered coincident with the WRITE command. Subsequent data elements will be registered on each successive positive clock edge. Upon completion of a fixed-length burst, assuming no other commands have been initiated, the DQs will remain High-Z and any additional input data will be ignored (see Figure 17 on page 30). A full-page burst will continue until terminated (at the end of the page, it will wrap to column 0 and continue).

Data for any WRITE burst may be truncated with a subsequent WRITE command, and data for a fixed-length WRITE burst may be immediately followed by data for a WRITE command. The new WRITE command can be issued on any clock following the previous WRITE command, and the data provided coincident with the new command applies to the new command. An example is shown in Figure 18 on page 30. Data  $n + 1$  is either the last of a burst of two or the last desired of a longer burst. This 64Mb SDRAM uses a pipelined architecture and therefore does not require the  $2n$  rule associated with a prefetch architecture. A WRITE command can be initiated on any clock cycle following a previous WRITE command. Full-speed random write accesses within a page can be performed to the same bank, as shown in Figure 19 on page 31, or each subsequent WRITE may be performed to a different bank.

Figure 16: WRITE Command

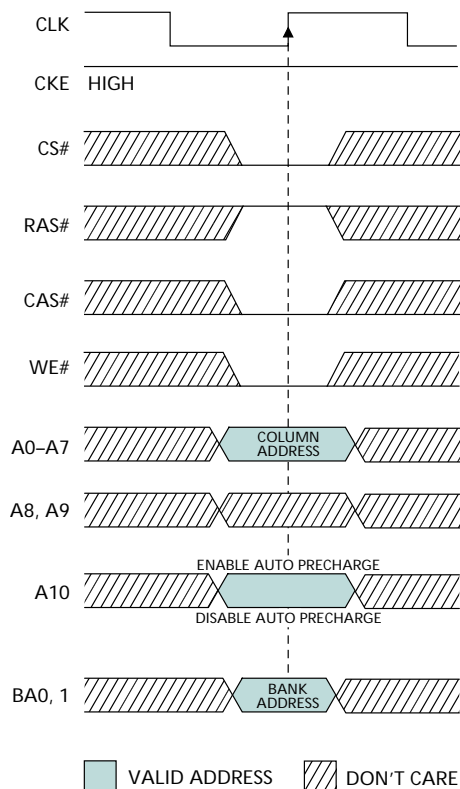


Figure 17: WRITE Burst

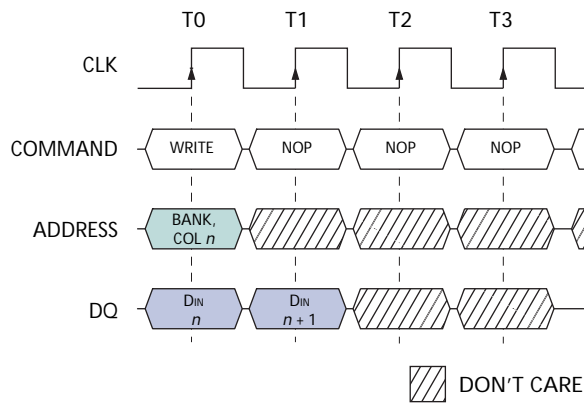
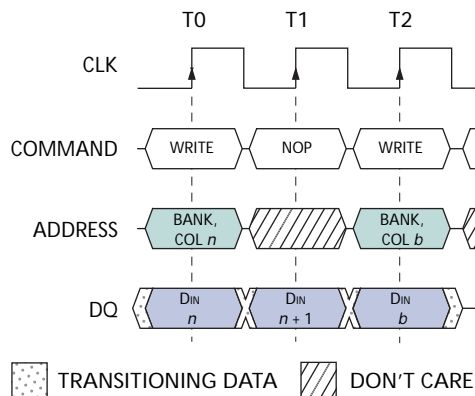


Figure 18: WRITE-to-WRITE



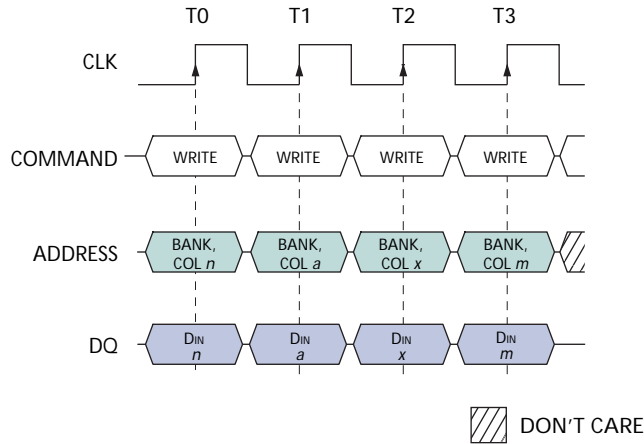
Note: DQM is LOW. Each WRITE command may be to any bank.

Data for any WRITE burst may be truncated with a subsequent READ command, and data for a fixed-length WRITE burst may be immediately followed by a READ command. Once the READ command is registered, the data inputs will be ignored, and writes will not be executed. An example is shown in Figure 20 on page 31. Data  $n + 1$  is either the last of a burst of two or the last desired of a longer burst.

Data for a fixed-length WRITE burst may be followed by, or truncated with, a PRECHARGE command to the same bank (provided that auto precharge was not activated), and a full-page WRITE burst may be truncated with a PRECHARGE command to the same bank. The PRECHARGE command should be issued  $t_{WR}$  after the clock edge at which the last desired input data element is registered. The “two-clock” write-back requires at least one clock plus time, regardless of frequency, in auto precharge mode. In addition, when truncating a WRITE burst, the DQM signal must be used to mask input data for the clock edge prior to, and the clock edge coincident with, the PRECHARGE command. An example is shown in Figure 21 on page 32. Data  $n + 1$  is either the last of a burst of two or the last desired of a longer burst. Following the PRECHARGE command, a subsequent command to the same bank cannot be issued until  $t_{RP}$  is met. The precharge will actually begin coincident with the clock-edge (T2 in Figure 21) on a “one-clock”  $t_{WR}$  and sometime between the first and second clock on a “two-clock”  $t_{WR}$  (between T2 and T3 in Figure 21).

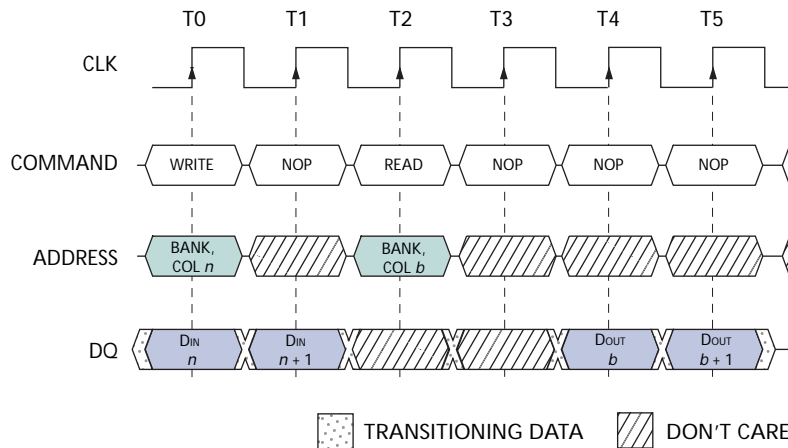
In the case of a fixed-length burst being executed to completion, a PRECHARGE command issued at the optimum time (as described above) provides the same operation that would result from the same fixed-length burst with auto precharge. The disadvantage of the PRECHARGE command is that it requires that the command and address buses be available at the appropriate time to issue the command; the advantage of the PRECHARGE command is that it can be used to truncate fixed-length or full-page bursts.

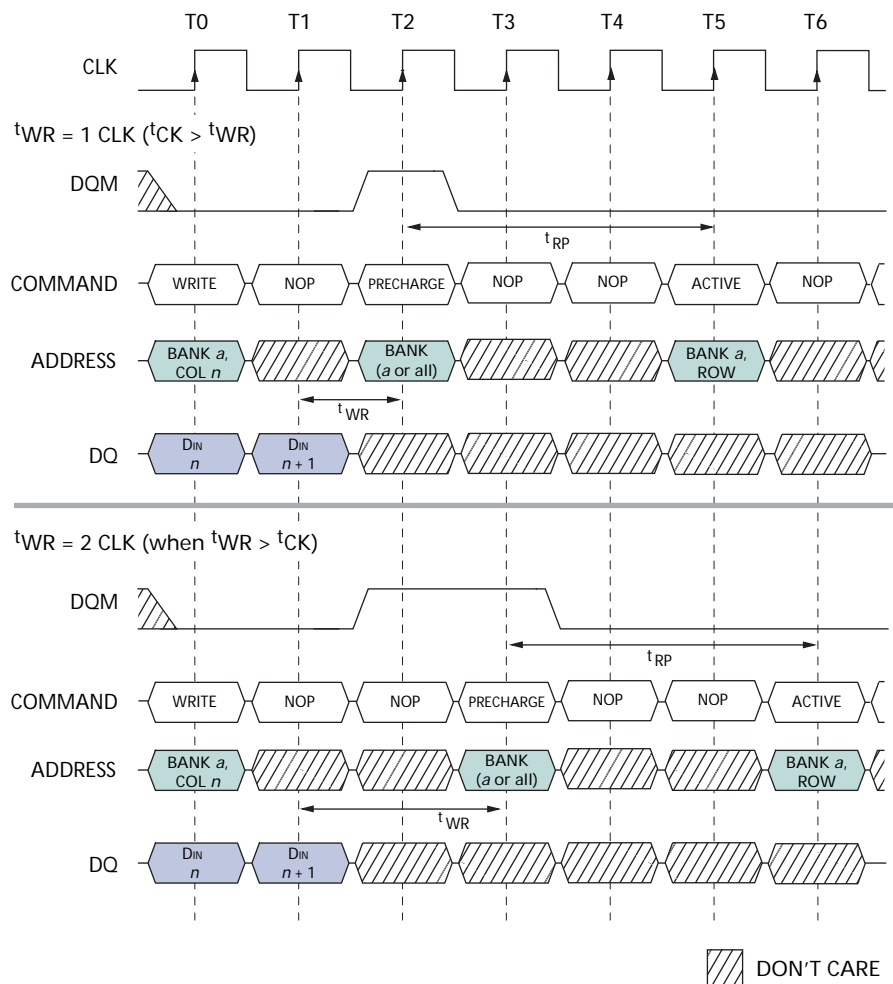
Figure 19: Random WRITE Cycles



Note: Each WRITE command may be to any bank. DQM is LOW.

Figure 20: WRITE-to-READ



**Figure 21: WRITE-to-PRECHARGE**


Note: DQM could remain LOW in this example if the WRITE burst is a fixed length of two.

Fixed-length or full-page WRITE bursts can be truncated with the BURST TERMINATE command. When truncating a WRITE burst, the input data applied coincident with the BURST TERMINATE command will be ignored. The last data written (provided that DQM is LOW at that time) will be the input data applied one clock previous to the BURST TERMINATE command. This is shown in Figure 22 on page 33, where data  $n$  is the last desired data element of a longer burst.

## PRECHARGE

The PRECHARGE command (Figure 23 on page 34) is used to deactivate the open row in a particular bank or the open row in all banks. The bank(s) will be available for a subsequent row access some specified time ( $t_{RP}$ ) after the PRECHARGE command is issued. Input A10 determines whether one or all banks are to be precharged, and in the case where only one bank is to be precharged, inputs BA0 and BA1 select the bank. When all banks are to be precharged, inputs BA0 and BA1 are treated as "Don't Care." After a bank has been precharged, it is in the idle state and must be activated prior to any READ or WRITE commands being issued to that bank.

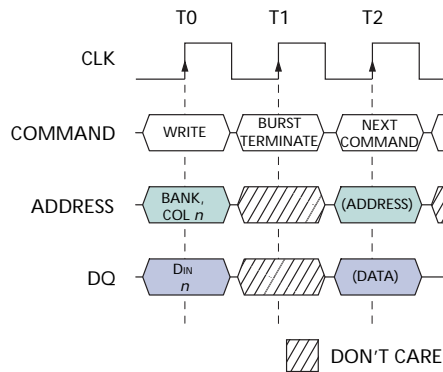


## Power-Down

Power-down occurs if CKE is registered LOW coincident with a NOP or COMMAND INHIBIT when no accesses are in progress (see Figure 24 on page 34). If power-down occurs when all banks are idle, this mode is referred to as precharge power-down; if power-down occurs when there is a row active in either bank, this mode is referred to as active power-down. Entering power-down deactivates the input and output buffers, excluding CKE, for maximum power savings while in standby. The device may not remain in the power-down state longer than the refresh period (64ms) since no refresh operations are performed in this mode.

The power-down state is exited by registering an NOP or COMMAND INHIBIT and CKE HIGH at the desired clock edge (meeting  $t^{\text{CKS}}$ ).

**Figure 22: Terminating a WRITE Burst**



Note: DQMs are LOW.

Figure 23: PRECHARGE Command

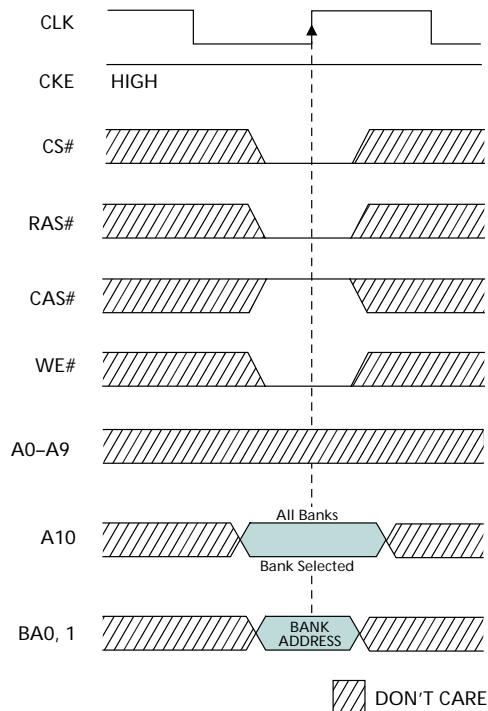
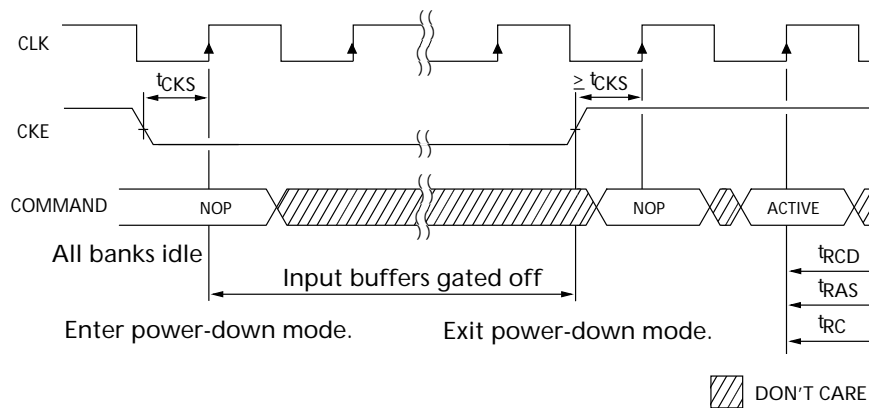


Figure 24: Power-Down



### Clock Suspend

The clock suspend mode occurs when a column access/burst is in progress and CKE is registered LOW. In the clock suspend mode, the internal clock is deactivated, “freezing” the synchronous logic.

For each positive clock edge on which CKE is sampled LOW, the next internal positive clock edge is suspended. Any command or data present on the input pins at the time of a suspended internal clock edge is ignored; any data present on the DQ pins remains driven; and burst counters are not incremented, as long as the clock is suspended (see examples in Figures 25 and 26 on page 35).

Clock suspend mode is exited by registering CKE HIGH; the internal clock and related operation will resume on the subsequent positive clock edge.

### Burst Read/Single Write

The burst read/single write mode is entered by programming the write burst mode bit (M9) in the mode register to a logic 1. In this mode, all WRITE commands result in the access of a single column location (burst of one), regardless of the programmed burst length. READ commands access columns according to the programmed burst length and sequence, just as in the normal mode of operation (M9 = 0).

Figure 25: Clock Suspend During WRITE Burst

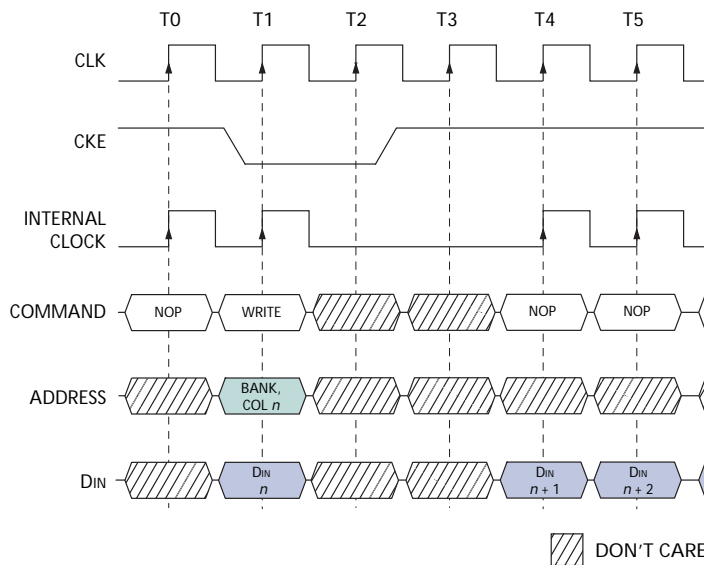
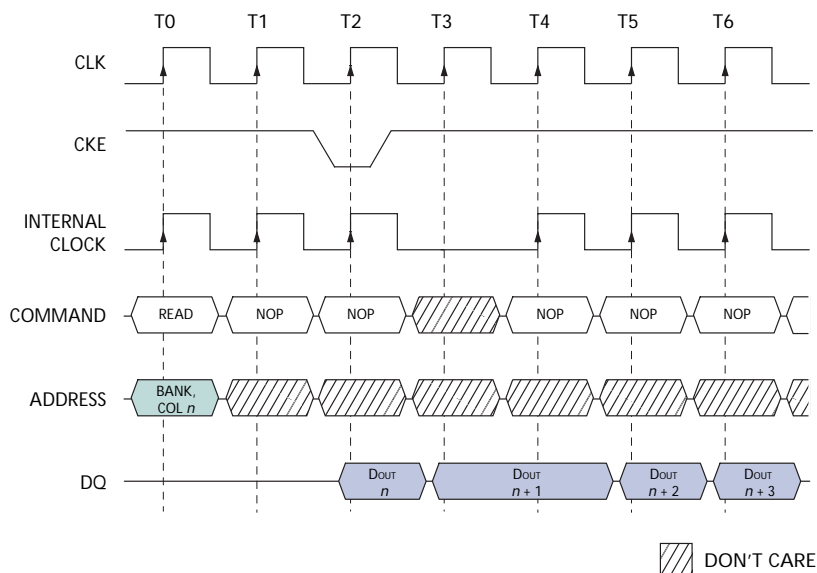


Figure 26: Clock Suspend During READ Burst



Note: For this example, CL = 2, BL = 4 or greater, and DQM is LOW.

### Concurrent Auto Precharge

An access command (READ or WRITE) to another bank while an access command with auto precharge enabled is executing is not allowed by SDRAMs, unless the SDRAM supports concurrent auto precharge. Micron SDRAMs support concurrent auto precharge. Four cases where concurrent auto precharge occurs are defined below.

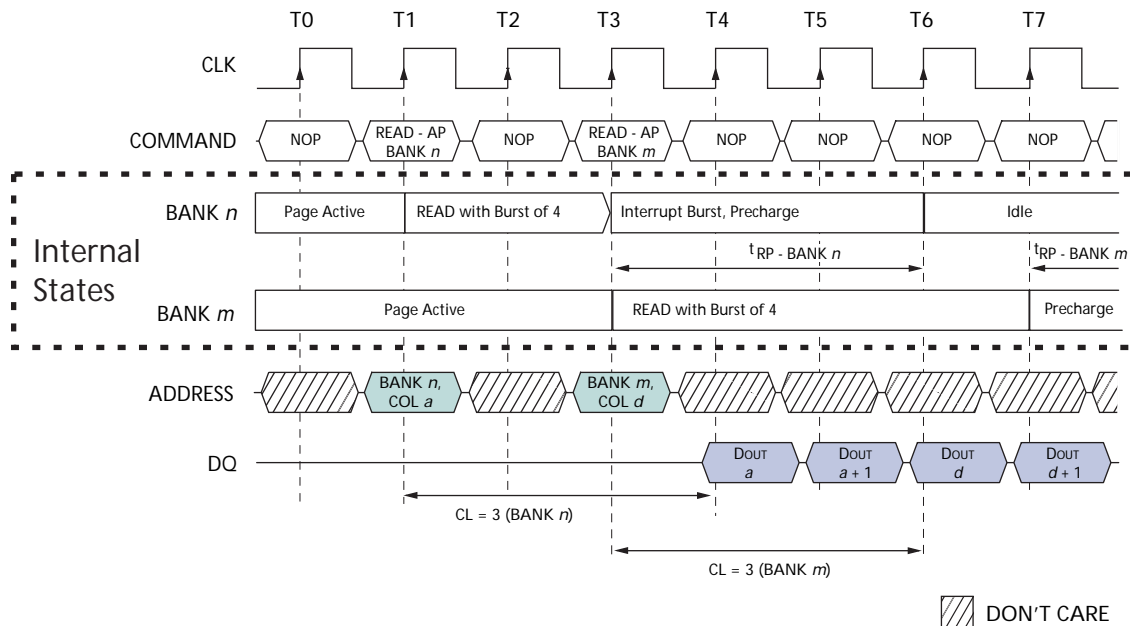
#### READ with Auto Precharge

- Interrupted by a READ (with or without auto precharge): A READ to bank *m* will interrupt a READ on bank *n*, CL later. The precharge to bank *n* will begin when the READ to bank *m* is registered (Figure 27).
- Interrupted by a WRITE (with or without auto precharge): A WRITE to bank *m* will interrupt a READ on bank *n* when registered. DQM should be used two clocks prior to the WRITE command to prevent bus contention. The precharge to bank *n* will begin when the WRITE to bank *m* is registered (Figure 28 on page 37).

#### WRITE with Auto Precharge

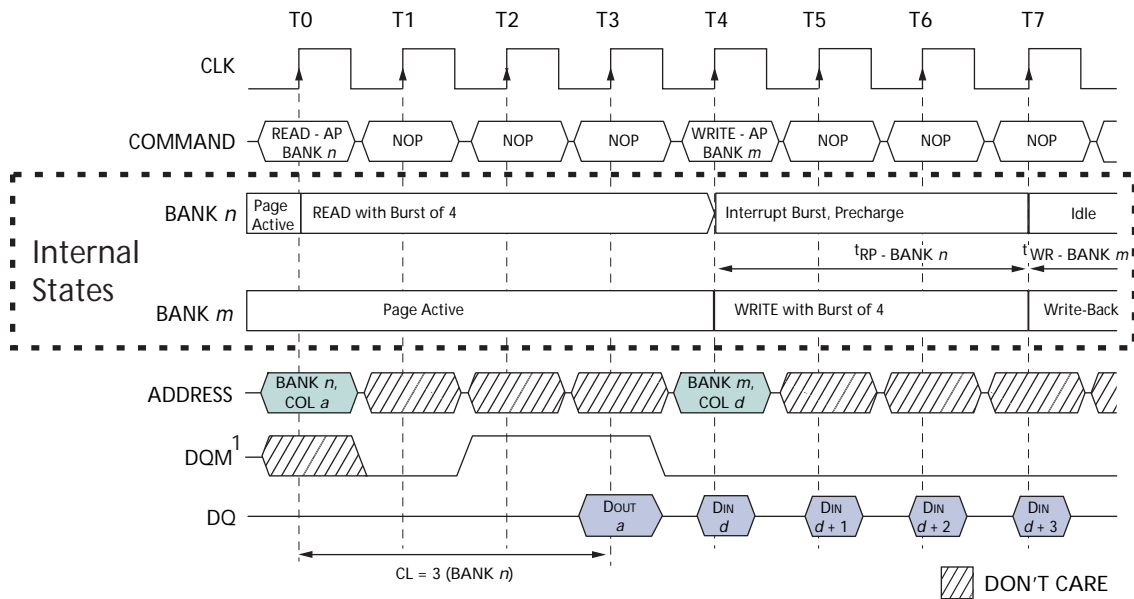
- Interrupted by a READ (with or without auto precharge): A READ to bank *m* will interrupt a WRITE on bank *n* when registered, with the data-out appearing CL later. The precharge to bank *n* will begin after  $t^{\text{WR}}$  is met, where  $t^{\text{WR}}$  begins when the READ to bank *m* is registered. The last valid WRITE to bank *n* will be data-in registered one clock prior to the READ to bank *m* (Figure 29 on page 37).
- Interrupted by a WRITE (with or without auto precharge): A WRITE to bank *m* will interrupt a WRITE on bank *n* when registered. The precharge to bank *n* will begin after  $t^{\text{WR}}$  is met, where  $t^{\text{WR}}$  begins when the WRITE to bank *m* is registered. The last valid data WRITE to bank *n* will be data registered one clock prior to a WRITE to bank *m* (Figure 30 on page 38).

Figure 27: READ with Auto Precharge Interrupted by a READ



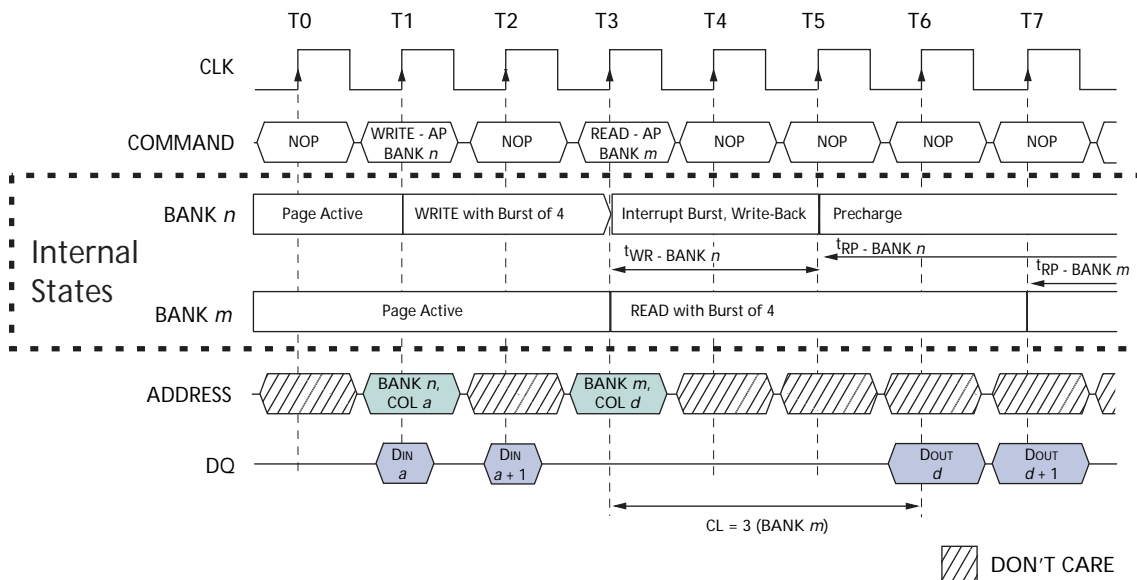
Note: DQM is LOW.

Figure 28: READ with Auto Precharge Interrupted by a WRITE



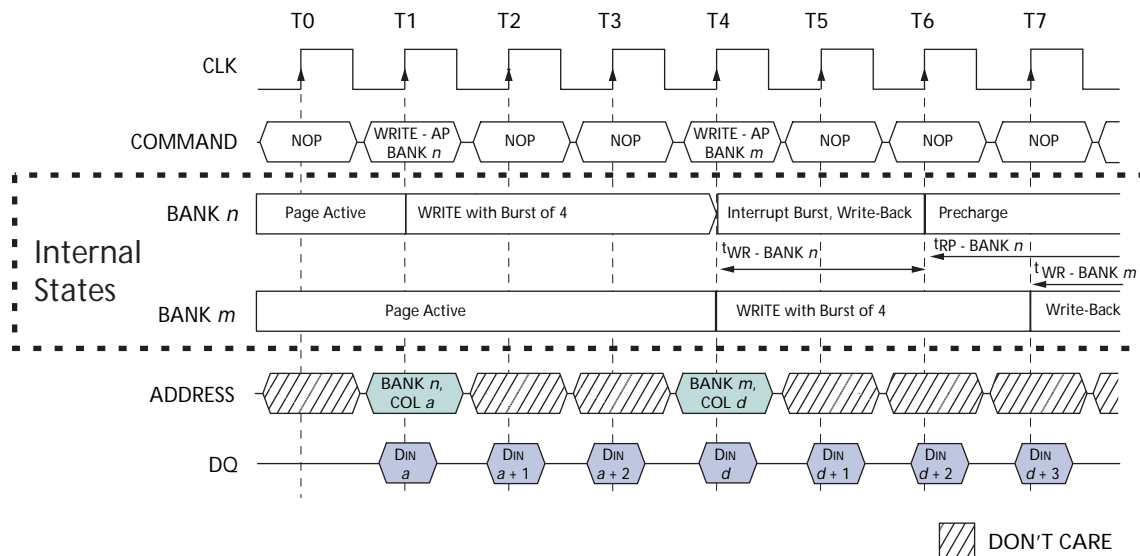
Notes: 1. DQM is HIGH at T2 to prevent DOUT a + 1 from contending with DIN d at T4.

Figure 29: WRITE with Auto Precharge Interrupted by a READ



Note: DQM is LOW.

Figure 30: WRITE with Auto Precharge Interrupted by a WRITE



Note: DQM is LOW.

Table 8: Truth Table 2 – CKE  
Notes: 1–4 apply to entire table

CKE <sub>n-1</sub>	CKE <sub>n</sub>	Current State	COMMAND <sub>n</sub>	ACTION <sub>n</sub>	Notes
L	L	Power-down	X	Maintain power-down	
		Self refresh	X	Maintain self refresh	
		Clock suspend	X	Maintain clock suspend	
L	H	Power-down	COMMAND INHIBIT or NOP	Exit power-down	5
		Self refresh	COMMAND INHIBIT or NOP	Exit self refresh	6
		Clock suspend	X	Exit clock suspend	7
H	L	All banks idle	COMMAND INHIBIT or NOP	Power-down entry	
		All banks idle	AUTO REFRESH	Self refresh entry	
		Reading or writing	WRITE or NOP	Clock suspend entry	
H	H		See Table 9 on page 39		

- Notes:
1. CKE<sub>n</sub> is the logic state of CKE at clock edge *n*; CKE<sub>n-1</sub> was the state of CKE at the previous clock edge.
  2. Current state is the state of the SDRAM immediately prior to clock edge *n*.
  3. COMMAND<sub>n</sub> is the command registered at clock edge *n*, and ACTION<sub>n</sub> is a result of COMMAND<sub>n</sub>.
  4. All states and sequences not shown are illegal or reserved.
  5. Exiting power-down at clock edge *n* will put the device in the all banks idle state in time for clock edge *n + 1* (provided that t<sup>CKS</sup> is met).
  6. Exiting self refresh at clock edge *n* will put the device in the all banks idle state after t<sup>XSR</sup> is met. COMMAND INHIBIT or NOP commands should be issued on any clock edges occurring during the t<sup>XSR</sup> period. A minimum of two NOP commands must be provided during t<sup>XSR</sup> period.
  7. After exiting clock suspend at clock edge *n*, the device will resume operation and recognize the next command at clock edge *n + 1*.

**Table 9: Truth Table 3 – Current State Bank *n*, Command to Bank *n***

Notes 1–6 apply to entire table; notes appear below and on next page

Current State	CS#	RAS#	CAS#	WE#	Command (Action)	Notes
Any	H	X	X	X	COMMAND INHIBIT (NOP/continue previous operation)	
	L	H	H	H	NO OPERATION (NOP/continue previous operation)	
Idle	L	L	H	H	ACTIVE (Select and activate row)	
	L	L	L	H	AUTO REFRESH	7
	L	L	L	L	LOAD MODE REGISTER	7
	L	L	H	L	PRECHARGE	11
Row active	L	H	L	H	READ (Select column and start READ burst)	10
	L	H	L	L	WRITE (Select column and start WRITE burst)	10
	L	L	H	L	PRECHARGE (Deactivate row in bank or banks)	8
Read (auto precharge disabled)	L	H	L	H	READ (Select column and start new READ burst)	10
	L	H	L	L	WRITE (Select column and start WRITE burst)	10
	L	L	H	L	PRECHARGE (Truncate READ burst, start PRECHARGE)	8
	L	H	H	L	BURST TERMINATE	9
Write (auto precharge disabled)	L	H	L	H	READ (Select column and start READ burst)	10
	L	H	L	L	WRITE (Select column and start new WRITE burst)	10
	L	L	H	L	PRECHARGE (Truncate WRITE burst, start PRECHARGE)	8
	L	H	H	L	BURST TERMINATE	9

- Notes:
- This table applies when  $CKE_{n-1}$  was HIGH and  $CKE_n$  is HIGH (see Table 8 on page 38) and after  $t^1XSR$  has been met (if the previous state was self refresh).
  - This table is bank-specific, except where noted; that is, the current state is for a specific bank and the commands shown are those allowed to be issued to that bank when in that state. Exceptions are covered in the notes below.
  - Current state definitions:
    - Idle: The bank has been precharged, and  $t^1RP$  has been met.
    - Row active: A row in the bank has been activated, and  $t^1RCD$  has been met. No data bursts/ accesses and no register accesses are in progress.
    - Read: A READ burst has been initiated, with auto precharge disabled, and has not yet terminated or been terminated.
    - Write: A WRITE burst has been initiated, with auto precharge disabled, and has not yet terminated or been terminated.
  - The following states must not be interrupted by a command issued to the same bank. COMMAND INHIBIT or NOP commands or allowable commands to the other bank should be issued on any clock edge occurring during these states. Allowable commands to the other bank are determined by its current state and Table 9 and according to Table 10 on page 41.
    - Precharging: Starts with registration of a PRECHARGE command and ends when  $t^1RP$  is met. After  $t^1RP$  is met, the bank will be in the idle state.
    - Row activating: Starts with registration of an ACTIVE command and ends when  $t^1RCD$  is met. After  $t^1RCD$  is met, the bank will be in the row active state.
    - Read with auto precharge enabled: Starts with registration of a READ command with auto precharge enabled and ends when  $t^1RP$  has been met. After  $t^1RP$  is met, the bank will be in the idle state.
    - Write w/auto precharge enabled: Starts with registration of a WRITE command with auto precharge enabled and ends when  $t^1RP$  has been met. After  $t^1RP$  is met, the bank will be in the idle state.

5. The following states must not be interrupted by any executable command; COMMAND INHIBIT or NOP commands must be applied on each positive clock edge during these states.

Refreshing:	Starts with registration of an AUTO REFRESH command and ends when $t_{RC}$ is met. After $t_{RC}$ is met, the SDRAM will be in the all banks idle state.
Accessing mode register:	Starts with registration of a LOAD MODE REGISTER command and ends when $t_{MRD}$ has been met. After $t_{MRD}$ is met, the SDRAM will be in the all banks idle state.
Precharging all:	Starts with registration of a PRECHARGE ALL command and ends when $t_{RP}$ is met. After $t_{RP}$ is met, all banks will be in the idle state.
6. All states and sequences not shown are illegal or reserved.
7. Not bank-specific; requires that all banks are idle.
8. May or may not be bank-specific; if all banks are to be precharged, all must be in a valid state for precharging.
9. Not bank-specific; BURST TERMINATE affects the most recent READ or WRITE burst, regardless of bank.
10. READs or WRITEs listed in the Command (Action) column include READs or WRITEs with auto precharge enabled and READs or WRITEs with auto precharge disabled.
11. Does not affect the state of the bank and acts as a NOP to that bank.



**Table 10: Truth Table 4 – Current State Bank *n*, Command to Bank *m***

Notes 1–6 apply to entire table; notes appear below and on next page

Current State	CS#	RAS#	CAS#	WE#	Command (Action)	Notes
Any	H	X	X	X	COMMAND INHIBIT (NOP/continue previous operation)	
	L	H	H	H	NO OPERATION (NOP/continue previous operation)	
Idle	X	X	X	X	Any command otherwise allowed to Bank <i>m</i>	
Row activating, active, or precharging	L	L	H	H	ACTIVE (Select and activate row)	
	L	H	L	H	READ (Select column and start READ burst)	7
	L	H	L	L	WRITE (Select column and start WRITE burst)	7
	L	L	H	L	PRECHARGE	
Read (auto precharge disabled)	L	L	H	H	ACTIVE (Select and activate row)	
	L	H	L	H	READ (Select column and start new READ burst)	7, 10
	L	H	L	L	WRITE (Select column and start WRITE burst)	7, 11
	L	L	H	L	PRECHARGE	9
Write (auto precharge disabled)	L	L	H	H	ACTIVE (Select and activate row)	
	L	H	L	H	READ (Select column and start READ burst)	7, 12
	L	H	L	L	WRITE (Select column and start new WRITE burst)	7, 13
	L	L	H	L	PRECHARGE	9
Read (with auto precharge)	L	L	H	H	ACTIVE (Select and activate row)	
	L	H	L	H	READ (Select column and start new READ burst)	7, 8, 14
	L	H	L	L	WRITE (Select column and start WRITE burst)	7, 8, 15
	L	L	H	L	PRECHARGE	9
Write (with auto precharge)	L	L	H	H	ACTIVE (Select and activate row)	
	L	H	L	H	READ (Select column and start READ burst)	7, 8, 16
	L	H	L	L	WRITE (Select column and start new WRITE burst)	7, 8, 17
	L	L	H	L	PRECHARGE	9

- Notes:
- This table applies when  $CKE_{n-1}$  was HIGH and  $CKE_n$  is HIGH (see Table 8 on page 38) and after  $t^*XSR$  has been met (if the previous state was self refresh).
  - This table describes an alternate bank operations, except where noted; that is, the current state is for bank *n* and the commands shown are those allowed to be issued to bank *m* (assuming that bank *m* is in such a state that the given command is allowable). Exceptions are covered in the notes below.
  - Current state definitions:
 

Idle:	The bank has been precharged, and $t^*RP$ has been met.
Row active:	A row in the bank has been activated, and $t^*RCD$ has been met. No data bursts/accesses and no register accesses are in progress.
Read:	A READ burst has been initiated, with auto precharge disabled and has not yet terminated or been terminated.
Write:	A WRITE burst has been initiated, with auto precharge disabled and has not yet terminated or been terminated.
Read w/auto precharge enabled:	Starts with registration of a READ command with auto precharge enabled and ends when $t^*RP$ has been met. After $t^*RP$ is met, the bank will be in the idle state.
Write w/auto precharge enabled:	Starts with registration of a WRITE command with auto precharge enabled and ends when $t^*RP$ has been met. After $t^*RP$ is met, the bank will be in the idle state.
  - AUTO REFRESH, SELF REFRESH, and LOAD MODE REGISTER commands may only be issued when all banks are idle.

5. A BURST TERMINATE command cannot be issued to another bank; it applies to the bank represented by the current state only.
6. All states and sequences not shown are illegal or reserved.
7. READs or WRITEs to bank  $m$  listed in the Command (Action) column include READs or WRITEs with auto precharge enabled and READs or WRITEs with auto precharge disabled.
8. Concurrent auto precharge: bank  $n$  will initiate the AUTO PRECHARGE command when its burst has been interrupted by bank  $m$ 's burst.
9. Burst in bank  $n$  continues as initiated.
10. For a READ without auto precharge interrupted by a READ (with or without auto precharge), the READ to bank  $m$  will interrupt the READ on bank  $n$ , CL later (Figure 10 on page 23).
11. For a READ without auto precharge interrupted by a WRITE (with or without auto precharge), the WRITE to bank  $m$  will interrupt the READ on bank  $n$  when registered (Figure 12 on page 25 and Figure 13 on page 26). DQM should be used one clock prior to the WRITE command to prevent bus contention.
12. For a WRITE without auto precharge interrupted by a READ (with or without auto precharge), the READ to bank  $m$  will interrupt the WRITE on bank  $n$  when registered (Figure 20 on page 31), with the data-out appearing CL later. The last valid WRITE to bank  $n$  will be data-in registered one clock prior to the READ to bank  $m$ .
13. For a WRITE without auto precharge interrupted by a WRITE (with or without auto precharge), the WRITE to bank  $m$  will interrupt the WRITE on bank  $n$  when registered (Figure 18 on page 30). The last valid WRITE to bank  $n$  will be data-in registered one clock prior to the READ to bank  $m$ .
14. For a READ with auto precharge interrupted by a READ (with or without auto precharge), the READ to bank  $m$  will interrupt the READ on bank  $n$ , CL later. The precharge to bank  $n$  will begin when the READ to bank  $m$  is registered (Figure 27 on page 36).
15. For a READ with auto precharge interrupted by a WRITE (with or without auto precharge), the WRITE to bank  $m$  will interrupt the READ on bank  $n$  when registered. DQM should be used two clocks prior to the WRITE command to prevent bus contention. The precharge to bank  $n$  will begin when the WRITE to bank  $m$  is registered (Figure 28 on page 37).
16. For a WRITE with auto precharge interrupted by a READ (with or without auto precharge), the READ to bank  $m$  will interrupt the WRITE on bank  $n$  when registered, with the data-out appearing CL later. The precharge to bank  $n$  will begin after  $t^1_{WR}$  is met, where  $t^1_{WR}$  begins when the READ to bank  $m$  is registered. The last valid WRITE to bank  $n$  will be data-in registered one clock prior to the READ to bank  $m$  (Figure 29 on page 37).
17. For a WRITE with auto precharge interrupted by a WRITE (with or without auto precharge), the WRITE to bank  $m$  will interrupt the WRITE on bank  $n$  when registered. The precharge to bank  $n$  will begin after  $t^1_{WR}$  is met, where  $t^1_{WR}$  begins when the WRITE to bank  $m$  is registered. The last valid WRITE to bank  $n$  will be data registered one clock prior to the WRITE to bank  $m$  (Figure 30 on page 38).

## Electrical Specifications

Stresses greater than those listed in Table 11 may cause permanent damage to the device. This is a stress rating only, and functional operation of the device at these or any other conditions above those indicated in the operational sections of this specification is not implied. Exposure to absolute maximum rating conditions for extended periods may affect reliability.

**Table 11: Absolute Maximum Ratings**

Parameter	Min	Max	Units
Voltage on VDD, VDDQ supply relative to Vss	-1V	+4.6	V
Voltage on inputs, NC or I/O pins relative to Vss	-1V	+4.6	V
Operating temperature			°C
T <sub>A</sub> (commercial)	0	70	
T <sub>A</sub> (extended; IT parts)	-40	+85	
Storage temperature (plastic)	-55	+150	°C
Power dissipation	-	1	W

## Temperature and Thermal Impedance

It is imperative that the SDRAM device's temperature specifications, shown in Table 12 on page 44, be maintained in order to ensure the junction temperature is in the proper operating range to meet data sheet specifications. An important step in maintaining the proper junction temperature is using the device's thermal impedances correctly. The thermal impedances are listed in Table 13 on page 44 for the applicable die revision and packages. These thermal impedance values vary according to the density, package, and particular design used for each device.

Incorrectly using thermal impedances can produce significant errors. Read Micron technical note TN-00-08, Thermal Applications prior to using the thermal impedances listed in Table 13 on page 44. To ensure the compatibility of current and future designs, contact Micron Applications Engineering to confirm thermal impedance values.

The SDRAM device's safe junction temperature range can be maintained when the T<sub>C</sub> specification is not exceeded. In applications where the device's ambient temperature is too high, use of forced air and/or heat sinks may be required in order to satisfy the case temperature specifications.

**Table 12: Temperature Limits**

Parameter	Symbol	Min	Max	Units	Notes
Operating case temperature: Commercial Industrial	$T_C$	0 -40	80 90	°C	1, 2, 3, 4
Junction temperature: Commercial Industrial	$T_J$	0 -40	85 95	°C	3
Ambient temperature: Commercial Industrial	$T_A$	0 -40	70 85	°C	3, 5
Peak reflow temperature	$T_{PEAK}$	-	260	°C	

- Notes:
1. MAX operating case temperature,  $T_C$ , is measured in the center of the package on the top side of the device, as shown in Figures 31 and 32 on page 45.
  2. Device functionality is not guaranteed if the device exceeds maximum  $T_C$  during operation.
  3. Both temperature specifications must be satisfied.
  4. The case temperature should be measured by gluing a thermocouple to the top center of the component. This should be done with a 1mm bead of conductive epoxy, as defined by the JEDEC EIA/JESD51 standards. Care should be taken to ensure the thermocouple bead is touching the case.
  5. Operating ambient temperature surrounding the package.

**Table 13: Thermal Impedance Simulated Values**

Die Revision	Package	Substrate	$\theta_{JA}$ (°C/W) Airflow = 0m/s	$\theta_{JA}$ (°C/W) Airflow = 1m/s	$\theta_{JA}$ (°C/W) Airflow = 2m/s	$\theta_{JB}$ (°C/W)	$\theta_{JC}$ (°C/W)
G	86-pin TSOP	4-layer	66.6	57.7	54.6	53.6	12.7
		90-ball FBGA	2-layer	70.6	57.6	69.5	35.7
	4-layer	54	47.3	52.7	35.2		

- Notes:
1. For designs expected to last beyond the die revision listed, contact Micron Applications Engineering to confirm thermal impedance values.
  2. Thermal resistance data is sampled from multiple lots and the values should be viewed as typical.
  3. These are estimates; actual results may vary.

Figure 31: Example Temperature Test Point Location, 86-Pin TSOP (Top View)

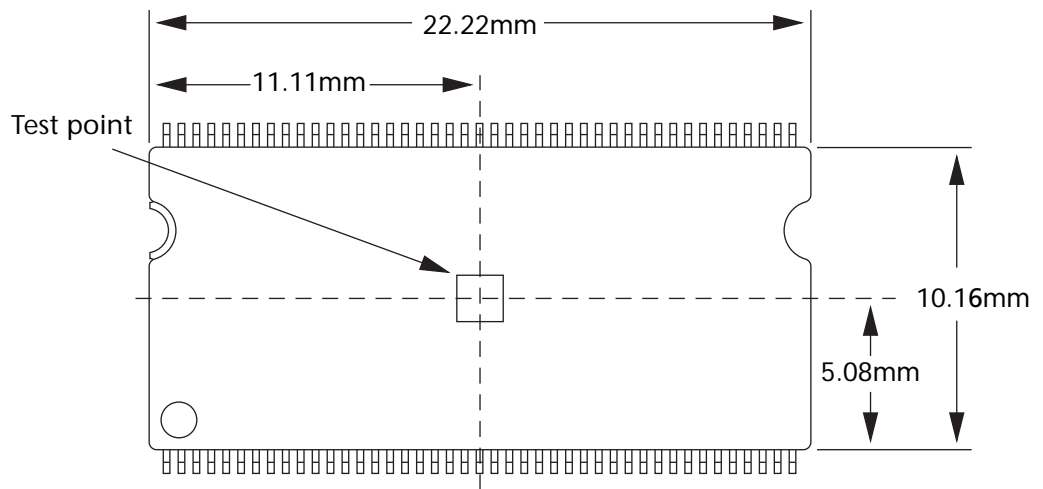
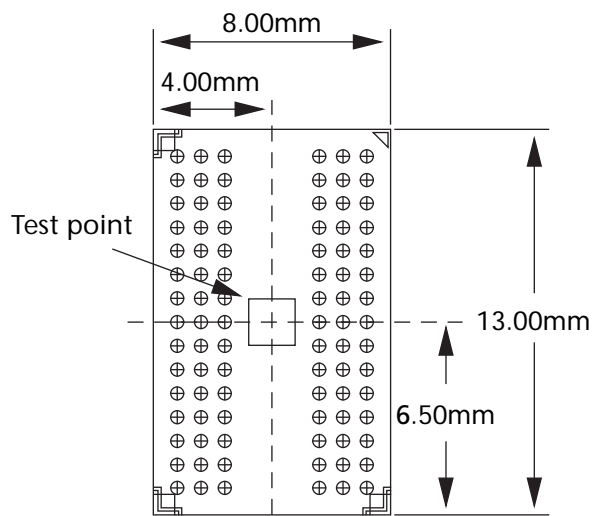


Figure 32: Example Temperature Test Point Location, 90-Ball FBGA (Top View)



**Table 14: DC Electrical Characteristics and Operating Conditions**

Notes 1, 6, 27 apply to entire table; notes appear on pages 49 and 50; VDD, VDDQ = +3.3V ±0.3V

Parameter/Condition	Symbol	Min	Max	Units	Notes
Supply voltage	VDD, VDDQ	3	3.6	V	
Input high voltage: Logic 1; All inputs	V <sub>IH</sub>	2	VDD + 0.3	V	22
Input low voltage: Logic 0; All inputs	V <sub>IL</sub>	-0.3	0.8	V	22
Input leakage current: Any input 0V ≤ V <sub>IN</sub> ≤ VDD (All other pins not under test = 0V)	I <sub>I</sub>	-5	5	μA	
Output leakage current: DQs are disabled; 0V ≤ V <sub>OUT</sub> ≤ VDDQ	I <sub>OZ</sub>	-5	5	μA	
Output levels: Output high voltage (I <sub>OUT</sub> = -4mA)	V <sub>OH</sub>	2.4	-	V	
Output low voltage (I <sub>OUT</sub> = 4mA)	V <sub>OL</sub>	-	0.4	V	

**Table 15: IDD Specifications and Conditions**

Notes 1, 6, 11, 13, 27 apply to entire table; notes appear on pages 49 and 50; VDD, VDDQ = +3.3V ±0.3V

Parameter/Condition	Symbol	Max				Units	Notes
		-5	-55	-6	-7		
Operating current: Active mode; Burst = 2; READ or WRITE; t <sub>RC</sub> ≥ t <sub>RC</sub> (MIN); CL = 3	I <sub>DD1</sub>	200	190	150	130	mA	3, 18, 19, 26
Standby current: Power-down mode; All banks idle; CKE = LOW	I <sub>DD2</sub>	2	2	2	2	mA	
Standby current: Active mode; CKE = HIGH; CS# = HIGH; All banks active after t <sub>RCD</sub> met; No accesses in progress	I <sub>DD3</sub>	80	70	60	50	mA	3, 12, 19, 26
Operating current: Burst mode; Continuous burst; READ or WRITE; All banks active; CL = 3	I <sub>DD4</sub>	280	260	180	160	mA	3, 18, 19, 26
Auto refresh current: CL = 3; CKE, CS# = HIGH	t <sub>RFC</sub> = t <sub>RFC</sub> (MIN) I <sub>DD5</sub>	225	225	225	225	mA	3, 12, 18, 19, 26
Self refresh current: CKE ≤ 0.2V	I <sub>DD6</sub>	2	2	2	2	mA	4

**Table 16: TSOP Capacitance**

Note 2 applies to entire table; notes appear on pages 49 and 50

Parameter	Symbol	Min	Max	Units
Input capacitance: CLK	Ci1	2.5	4.0	pF
Input capacitance: All other input-only pins	Ci2	2.5	4.0	pF
Input/output capacitance: DQs	Cio	4.0	6.5	pF

**Table 17: VFBGA Capacitance**

Note 2 applies to entire table; notes appear on pages 49 and 50

Parameter	Symbol	Min	Max	Units
Input capacitance: CLK	Ci1	2.5	4.0	pF
Input capacitance: All other input-only balls	Ci2	2.5	4.0	pF
Input/output capacitance: DQs	Cio	4.0	6.5	pF

**Table 18: Electrical Characteristics and Recommended AC Operating Conditions**

 Notes 5, 6, 8, 9, 11 apply to entire table; notes appear on pages 49 and 50; V<sub>DD</sub>, V<sub>DDQ</sub> = +3.3V ±0.3V

AC Characteristics		-5		-55		-6		-7		Units	Notes	
Parameter	Symbol	Min	Max	Min	Max	Min	Max	Min	Max			
Access time from CLK (positive edge)	CL = 3	t <sub>AC</sub> (3)	-	4.5	-	5	-	5.5	-	5.5	ns	
	CL = 2	t <sub>AC</sub> (2)	-	-	-	-	-	7.5	-	8	ns	
	CL = 1	t <sub>AC</sub> (1)	-	-	-	-	-	17	-	17	ns	
Address hold time	t <sub>AH</sub>	1	-	1	-	1	-	1	-	ns		
Address setup time	t <sub>AS</sub>	1.5	-	1.5	-	1.5	-	2	-	ns		
CLK high-level width	t <sub>CH</sub>	2	-	2	-	2.5	-	2.75	-	ns		
CLK low-level width	t <sub>CL</sub>	2	-	2	-	2.5	-	2.75	-	ns		
Clock cycle time	CL = 3	t <sub>CK</sub> (3)	5	-	5.5	-	6	-	7	-	ns	23
	CL = 2	t <sub>CK</sub> (2)	-	-	-	-	10	-	10	-	ns	23
	CL = 1	t <sub>CK</sub> (1)	-	-	-	-	20	-	20	-	ns	23
CKE hold time	t <sub>CKH</sub>	1	-	1	-	1	-	1	-	ns		
CKE setup time	t <sub>CKS</sub>	1.5	-	1.5	-	1.5	-	2	-	ns		
CS#, RAS#, CAS#, WE#, DQM hold time	t <sub>CMH</sub>	1	-	1	-	1	-	1	-	ns		
CS#, RAS#, CAS#, WE#, DQM setup time	t <sub>CMS</sub>	1.5	-	1.5	-	1.5	-	2	-	ns		
Data-in hold time	t <sub>DH</sub>	1	-	1	-	1	-	1	-	ns		
Data-in setup time	t <sub>DS</sub>	1.5	-	1.5	-	1.5	-	2	-	ns		
Data-out High-Z time	CL = 3	t <sub>HZ</sub> (3)	4.5	-	5	-	-	5.5	-	5.5	ns	10
	CL = 2	t <sub>HZ</sub> (2)	-	-	-	-	-	7.5	-	8	ns	10
	CL = 1	t <sub>HZ</sub> (1)	-	-	-	-	-	17	-	17	ns	10
Data-out Low-Z time	t <sub>LZ</sub>	1	-	1	-	1	-	1	-	ns		
Data-out hold time	t <sub>OH</sub>	1.5	-	2	-	2	-	2.5	-	ns		
ACTIVE-to-PRECHARGE command	t <sub>RAS</sub>	38.7	120k	38.7	120k	42	120k	42	120k	ns		
ACTIVE-to-ACTIVE command period	t <sub>RC</sub>	55	-	55	-	60	-	70	-	ns		
AUTO REFRESH period	t <sub>RFC</sub>	60	-	60	-	60	-	70	-	ns		
ACTIVE to READ or WRITE delay	t <sub>RCD</sub>	15	-	16.5	-	18	-	20	-	ns		

**Table 18: Electrical Characteristics and Recommended AC Operating Conditions (continued)**

Notes 5, 6, 8, 9, 11 apply to entire table; notes appear on pages 49 and 50; VDD, VDDQ = +3.3V ±0.3V

AC Characteristics		-5		-55		-6		-7		Units	Notes
Parameter	Symbol	Min	Max	Min	Max	Min	Max	Min	Max		
Refresh period (4,096 rows)	$t_{REF}$	–	64	–	64	–	64	–	64	ms	
PRECHARGE command period	$t_{RP}$	15	–	16.5	–	18	–	20	–	ns	
ACTIVE bank <i>a</i> to ACTIVE bank <i>b</i> command	$t_{RRD}$	10	–	11	–	12	–	14	–	ns	25
Transition time	$t_T$	0.3	1.2	0.3	1.2	0.3	1.2	0.3	1.2	ns	7
Write recovery time	$t_{WR}$	2	–	2	–	1CLK + 6ns	–	1CLK + 7ns	–	$t_{CK}$	24
						12ns	–	14ns	–	ns	28
Exit self refresh to ACTIVE command	$t_{XSR}$	55	–	55	–	70	–	70	–	ns	20

**Table 19: AC Functional Characteristics**

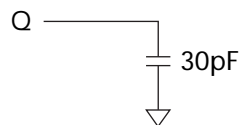
Notes 5, 6, 8, 9, 11 apply to entire table; notes appear on pages 49 and 50

Parameter	Symbol	-5	-55	-6	-7	Units	Notes
READ/WRITE command to READ/WRITE command	$t_{CCD}$	1	1	1	1	$t_{CK}$	17
CKE to clock disable or power-down entry mode	$t_{CKED}$	1	1	1	1	$t_{CK}$	14
CKE to clock enable or power-down exit setup mode	$t_{PED}$	1	1	1	1	$t_{CK}$	14
DQM to input data delay	$t_{DQD}$	0	0	0	0	$t_{CK}$	17
DQM to data mask during WRITES	$t_{DQM}$	0	0	0	0	$t_{CK}$	17
DQM to data High-Z during READS	$t_{DOZ}$	2	2	2	2	$t_{CK}$	17
WRITE command to input data delay	$t_{DWD}$	0	0	0	0	$t_{CK}$	17
Data-in to ACTIVE command	CL = 3	$t_{DAL} (3)$	5	5	5	$t_{CK}$	15, 21
	CL = 2	$t_{DAL} (2)$	–	–	4	$t_{CK}$	15, 21
	CL = 1	$t_{DAL} (1)$	–	–	3	$t_{CK}$	15, 21
Data-in to PRECHARGE command	$t_{DPL}$	2	2	2	2	$t_{CK}$	16, 21
Last data-in to burst stop command	$t_{BDL}$	1	1	1	1	$t_{CK}$	17
Last data-in to new READ/WRITE command	$t_{CDL}$	1	1	1	1	$t_{CK}$	17
Last data-in to PRECHARGE command	$t_{RDL}$	2	2	2	2	$t_{CK}$	16, 21
LOAD MODE REGISTER command to ACTIVE or REFRESH command	$t_{MRD}$	2	2	2	2	$t_{CK}$	26
Data-out to High-Z from PRECHARGE command	CL = 3	$t_{ROH} (3)$	3	3	3	$t_{CK}$	17
	CL = 2	$t_{ROH} (2)$	–	–	2	$t_{CK}$	17
	CL = 1	$t_{ROH} (1)$	–	–	–	$t_{CK}$	17



## Notes

1. All voltages referenced to VSS.
2. This parameter is sampled. VDD, VDDQ = +3.3V; f = 1 MHz, T<sub>A</sub> = 25°C; pin under test biased at 1.4V. AC can range from 0pF to 6pF.
3. I<sub>DD</sub> is dependent on output loading and cycle rates. Specified values are obtained with minimum cycle time and the outputs open.
4. Enables on-chip refresh and address counters.
5. The minimum specifications are used only to indicate cycle time at which proper operation over the full temperature range (0°C ≤ T<sub>A</sub> ≤ +70°C and -40°C ≤ T<sub>A</sub> ≤ +85°C for IT parts) is ensured.
6. An initial pause of 100μs is required after power-up, followed by two AUTO REFRESH commands, before proper device operation is ensured (VDD and VDDQ must be powered up simultaneously. VSS and VSSQ must be at same potential). The two AUTO REFRESH command wake-ups should be repeated any time the t<sub>REF</sub> refresh requirement is exceeded.
7. AC characteristics assume t<sub>T</sub> = 1ns.
8. In addition to meeting the transition rate specification, the clock and CKE must transit between V<sub>IH</sub> and V<sub>IL</sub> (or between V<sub>IL</sub> and V<sub>IH</sub>) in a monotonic manner.
9. Outputs measured at 1.5V with equivalent load:

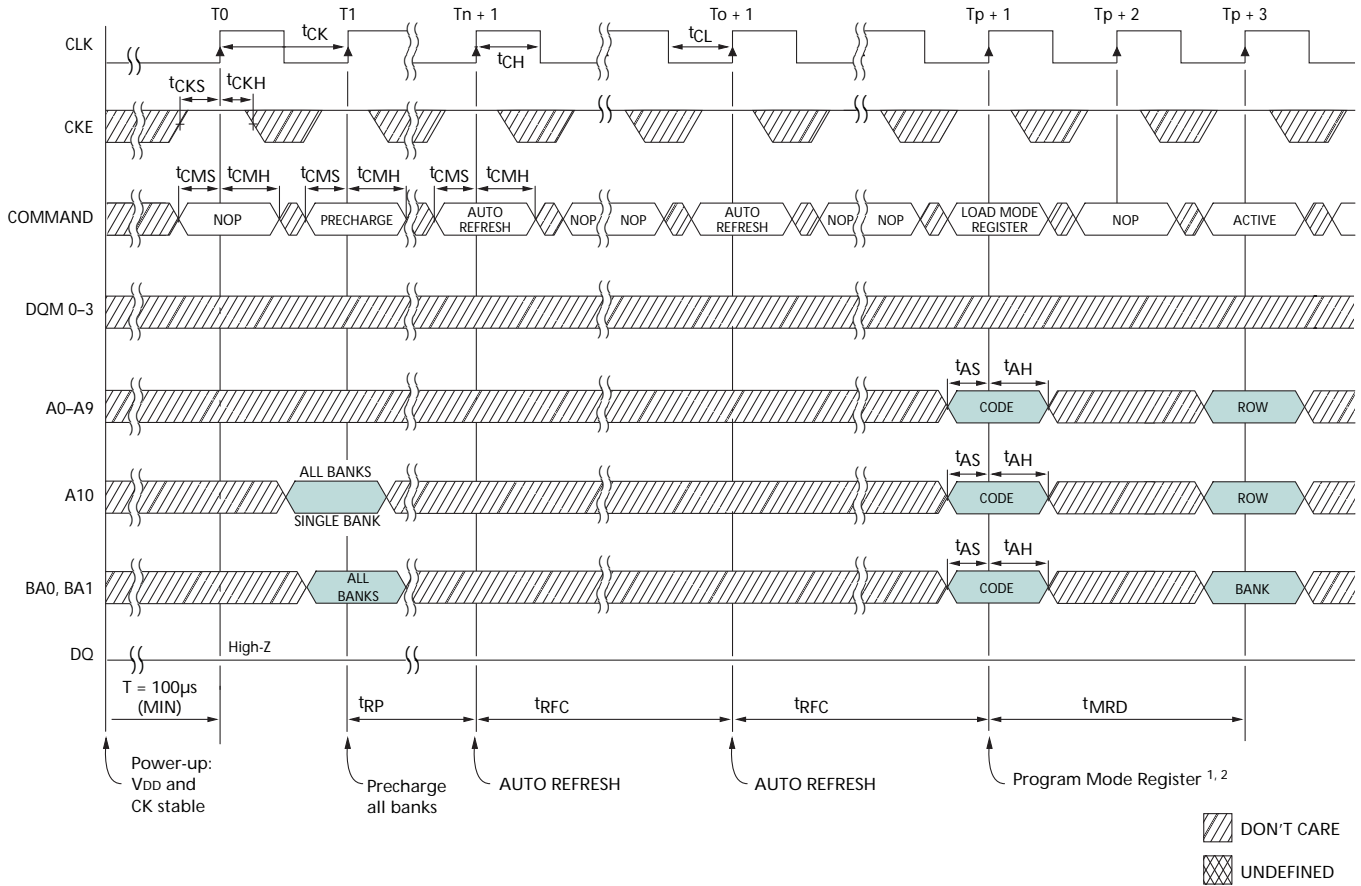


10. t<sub>HZ</sub> defines the time at which the output achieves the open circuit condition; it is not a reference to V<sub>OH</sub> or V<sub>OL</sub>. The last valid data element will meet t<sub>OH</sub> before going High-Z.
11. AC timing and I<sub>DD</sub> tests have V<sub>IL</sub> = 0.25 and V<sub>IH</sub> = 2.75, with timing referenced to 1.5V crossover point.
12. Other input signals are allowed to transition no more than once in any two-clock period and are otherwise at valid V<sub>IH</sub> or V<sub>IL</sub> levels.
13. I<sub>DD</sub> specifications are tested after the device is properly initialized.
14. Timing is actually specified by t<sub>CKS</sub>; clock(s) specified as a reference only at minimum cycle rate.
15. Timing is actually specified by t<sub>WR</sub> plus t<sub>RP</sub>; clock(s) is (are) specified as a reference only at minimum cycle rate.
16. Timing actually specified by t<sub>WR</sub>.
17. Required clocks are specified by JEDEC functionality and are not dependent on any timing parameter.
18. The I<sub>DD</sub> current will decrease as the CL is reduced. This is due to the fact that the maximum cycle rate is slower as the CL is reduced.
19. Address transitions average one transition every two clocks.
20. CLK must be toggled a minimum of two times during this period.
21. Based on t<sub>CK</sub> = 143 MHz for -7, 166 MHz for -6, 183 MHz for -55, and 200 MHz for -5.
22. V<sub>IH</sub> overshoot: V<sub>IH</sub>(MAX) = VDDQ + 1.2V for a pulse width ≤ 3ns, and the pulse width cannot be greater than one-third the cycle rate. V<sub>IL</sub> undershoot: V<sub>IL</sub>(MIN) = -1.2V for a pulse width ≤ 3ns, and the pulse width cannot be greater than one-third the cycle rate.

23. The clock frequency must remain constant during access or precharge states (READ, WRITE, including  $t_{WR}$ , and PRECHARGE commands). CKE may be used to reduce the data rate.
24. Auto precharge mode only.
25. JEDEC and PC100 specify three clocks.
26.  $t_{CK} = 7\text{ns}$  for -7,  $6\text{ns}$  for -6,  $5.5\text{ns}$  for -55, and  $5\text{ns}$  for -5.
27.  $V_{DD}(\text{MIN}) = 3.135\text{V}$  for -6, -55, and -5 speed grades.
28. Check factory for availability of specially screened devices having  $t_{WR} = 10\text{ns}$ .  $t_{WR} = 1 t_{CK}$  for 100 MHz and slower ( $t_{CK} = 10\text{ns}$  and higher) in manual precharge.

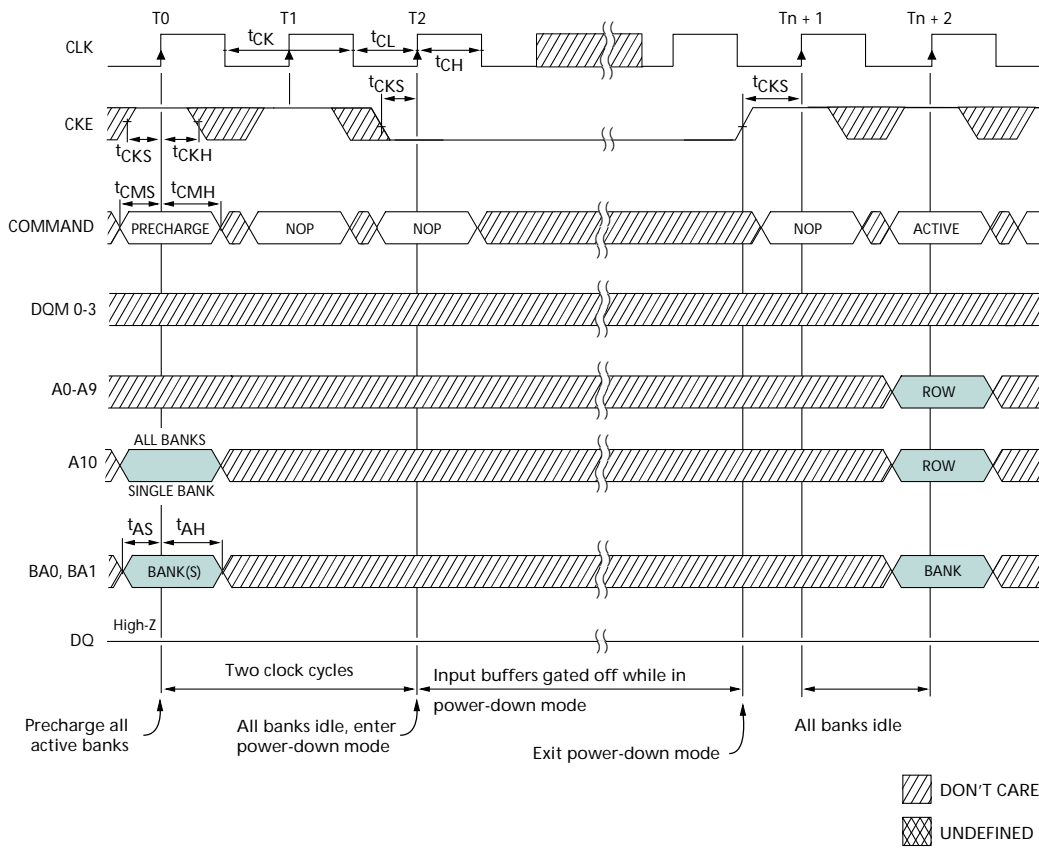
## Timing Diagrams

Figure 33: Initialize and Load Mode Register



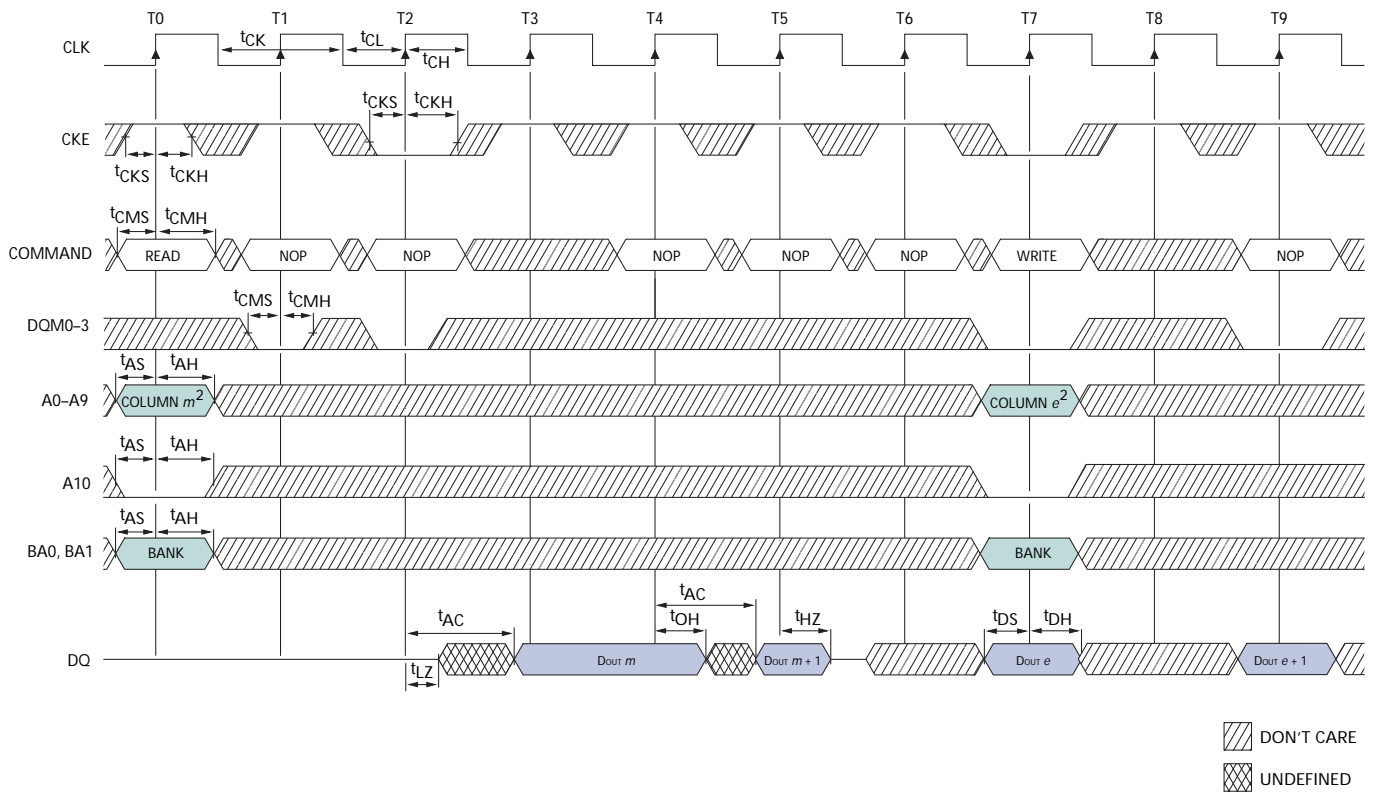
- Notes: 1. The mode register may be loaded prior to the AUTO REFRESH cycles if desired.  
2. Outputs are guaranteed High-Z after command is issued.

Figure 34: Power-Down Mode



Note: Violating refresh requirements during power-down may result in a loss of data.

Figure 35: Clock Suspend Mode



- Notes: 1. For this example, BL = 2, CL = 3, and auto precharge is disabled.  
2. A8 and A9 = "Don't Care."

Figure 36: Auto Refresh Mode

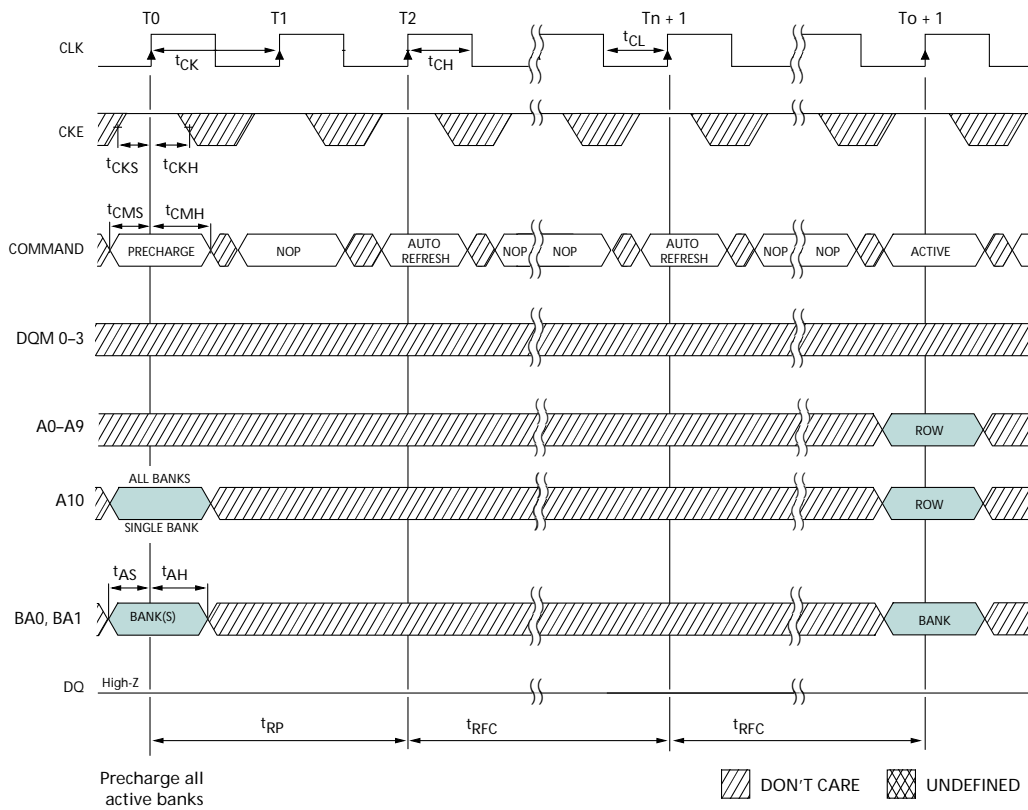


Figure 37: Self Refresh Mode

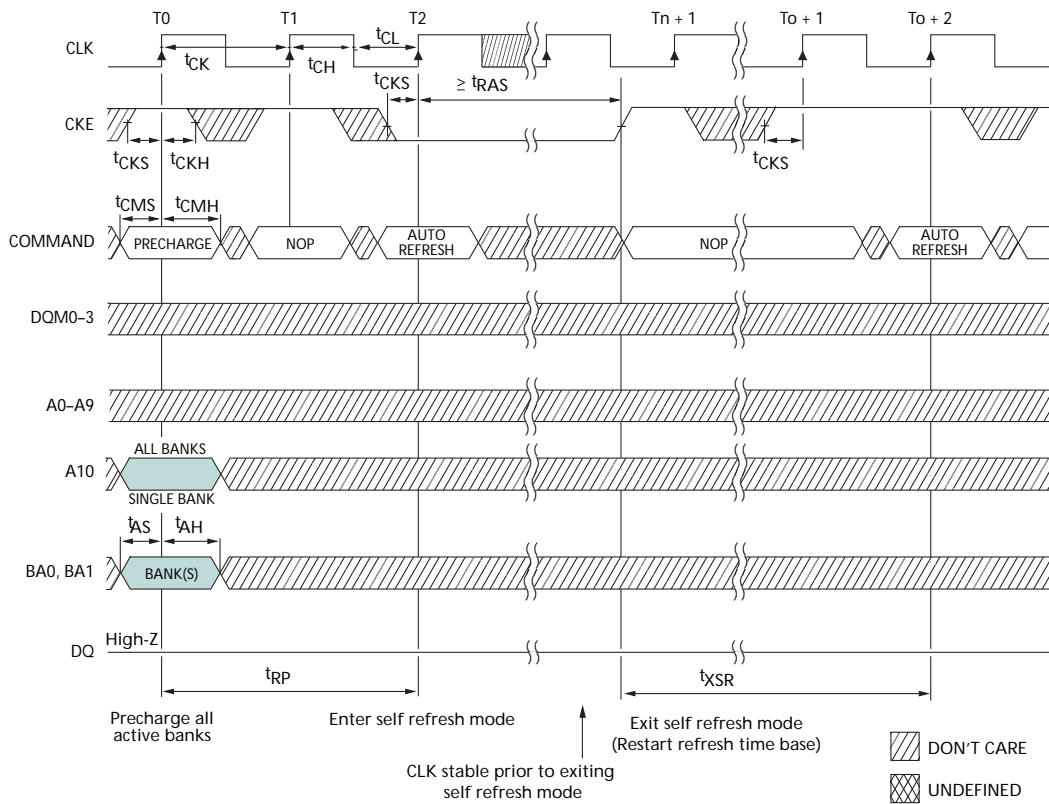
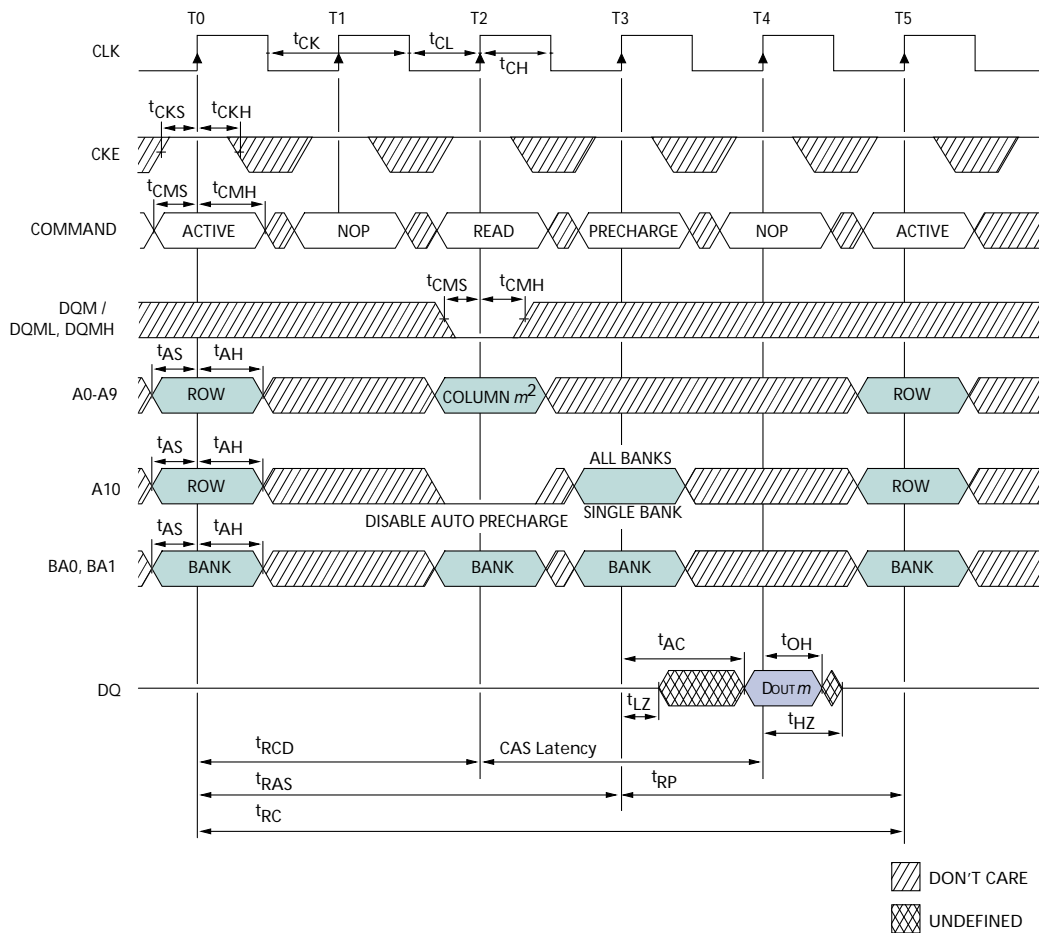


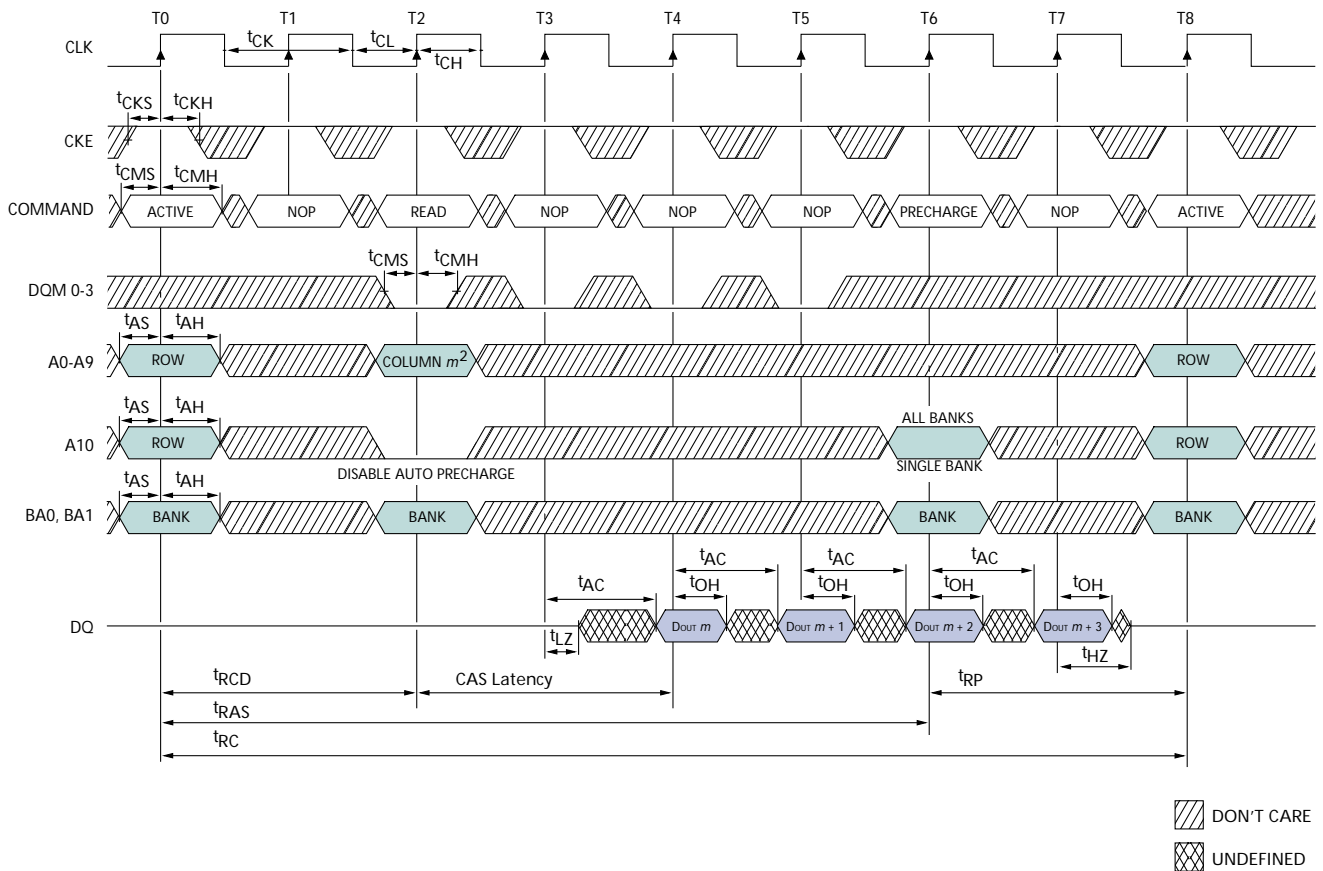
Figure 38: Single READ



- Notes: 1. For this example, BL = 1, CL = 2, and the READ burst is followed by a "manual" PRECHARGE.  
2. A8, A9 = "Don't Care."

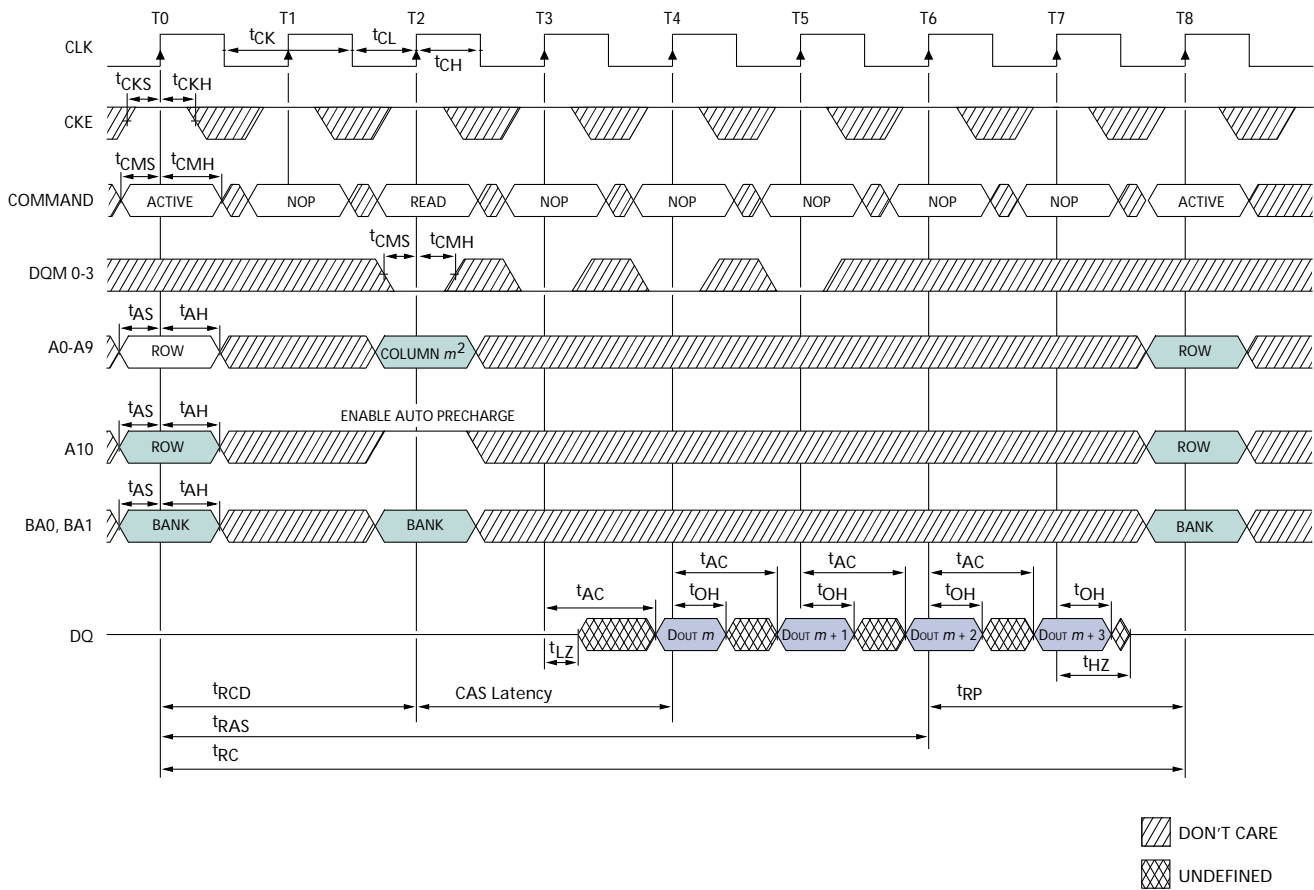


Figure 39: Single READ - Without Auto Precharge



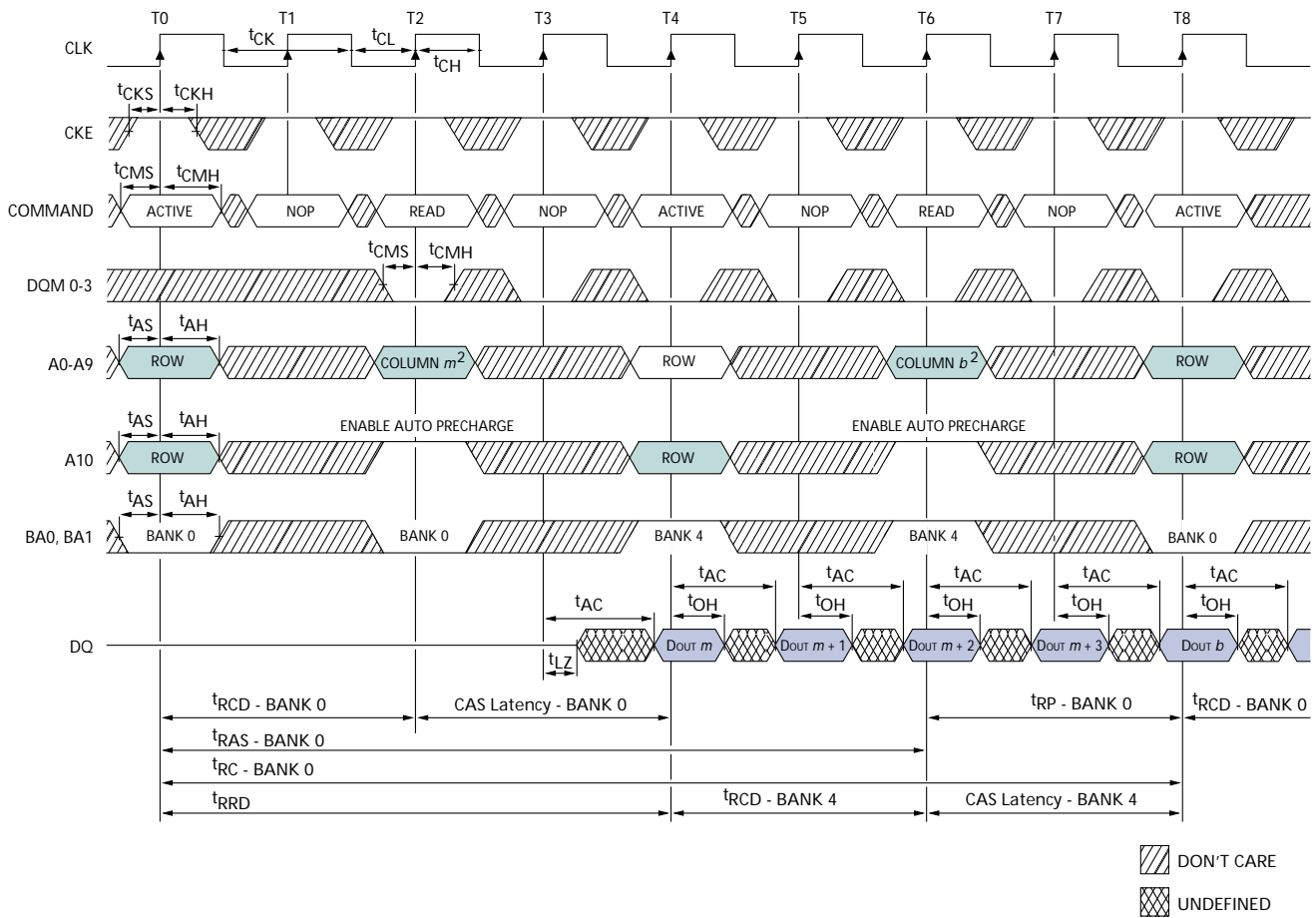
- Notes: 1. For this example, BL = 4, CL = 2, and the READ is followed by a "manual" PRECHARGE.  
2. A8 and A9 = "Don't Care."

Figure 40: READ – with Auto Precharge



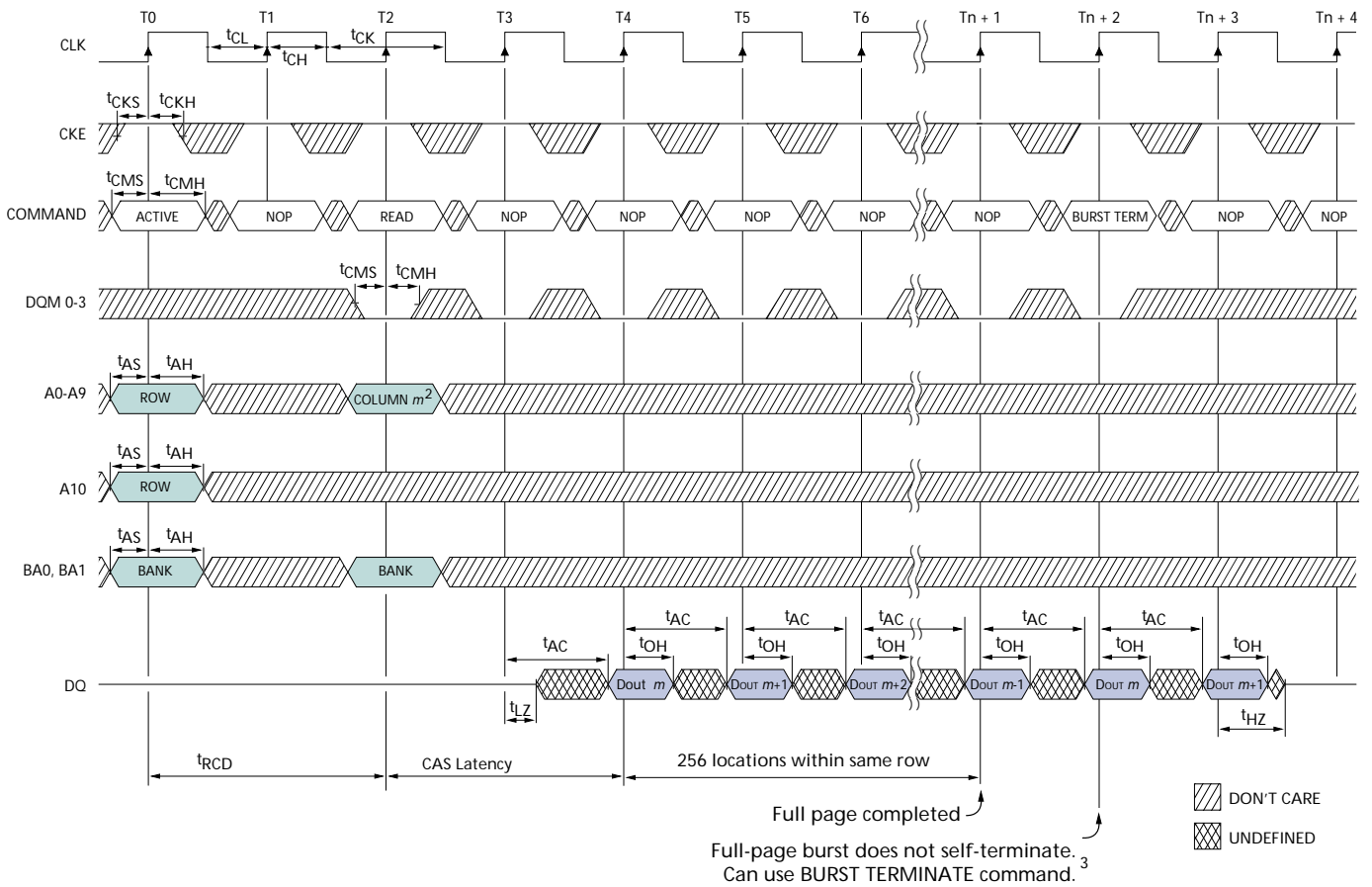
- Notes: 1. For this example, BL = 4 and CL = 2.  
2. A8 and A9 = "Don't Care."

Figure 41: Alternating Bank Read Accesses



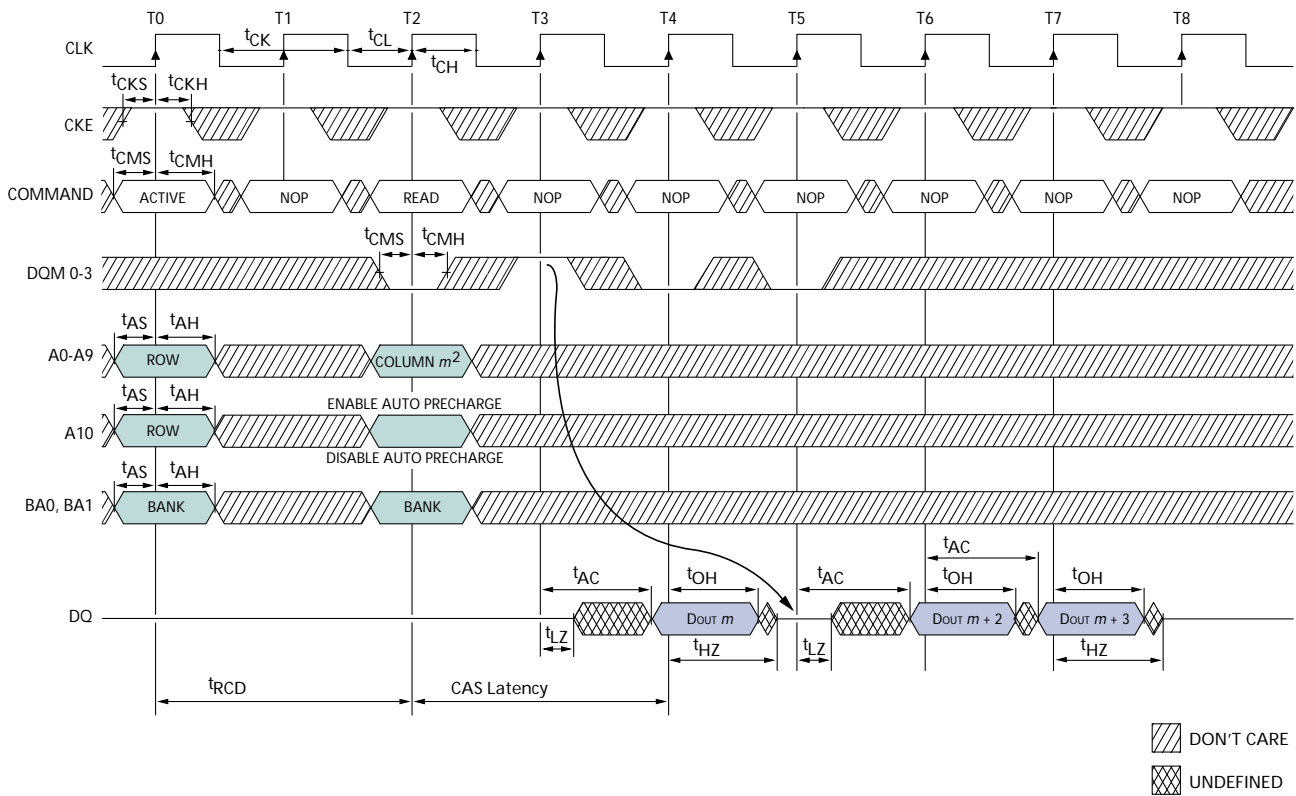
- Notes: 1. For this example, BL = 4 and CL = 2.  
2. A8 and A9 = "Don't Care."

Figure 42: READ – Full-Page Burst



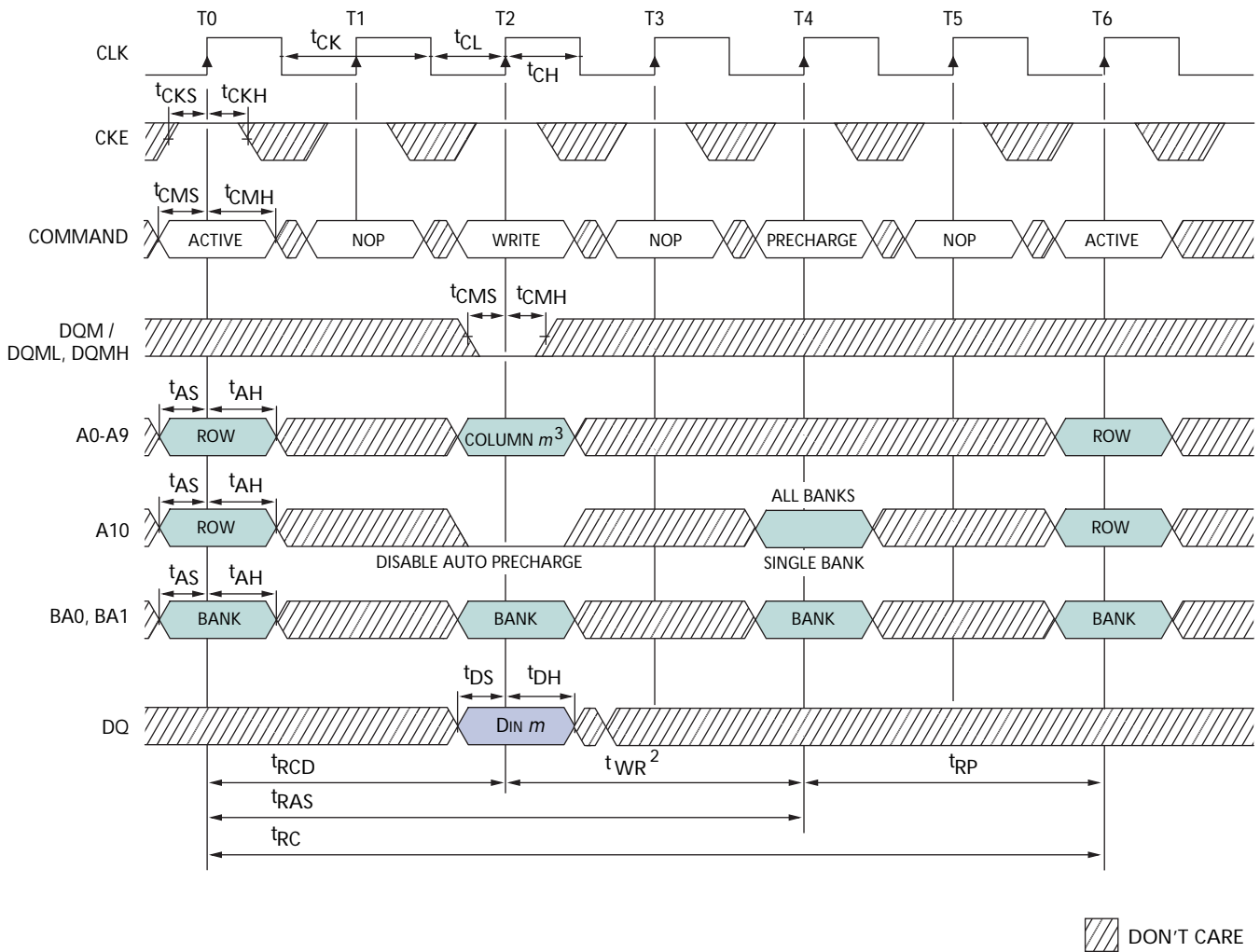
- Notes:
1. For this example, CL = 2.
  2. A8 and A9 = "Don't Care."
  3. Page left open; no  $t_{RP}$ .

Figure 43: READ – DQM Operation



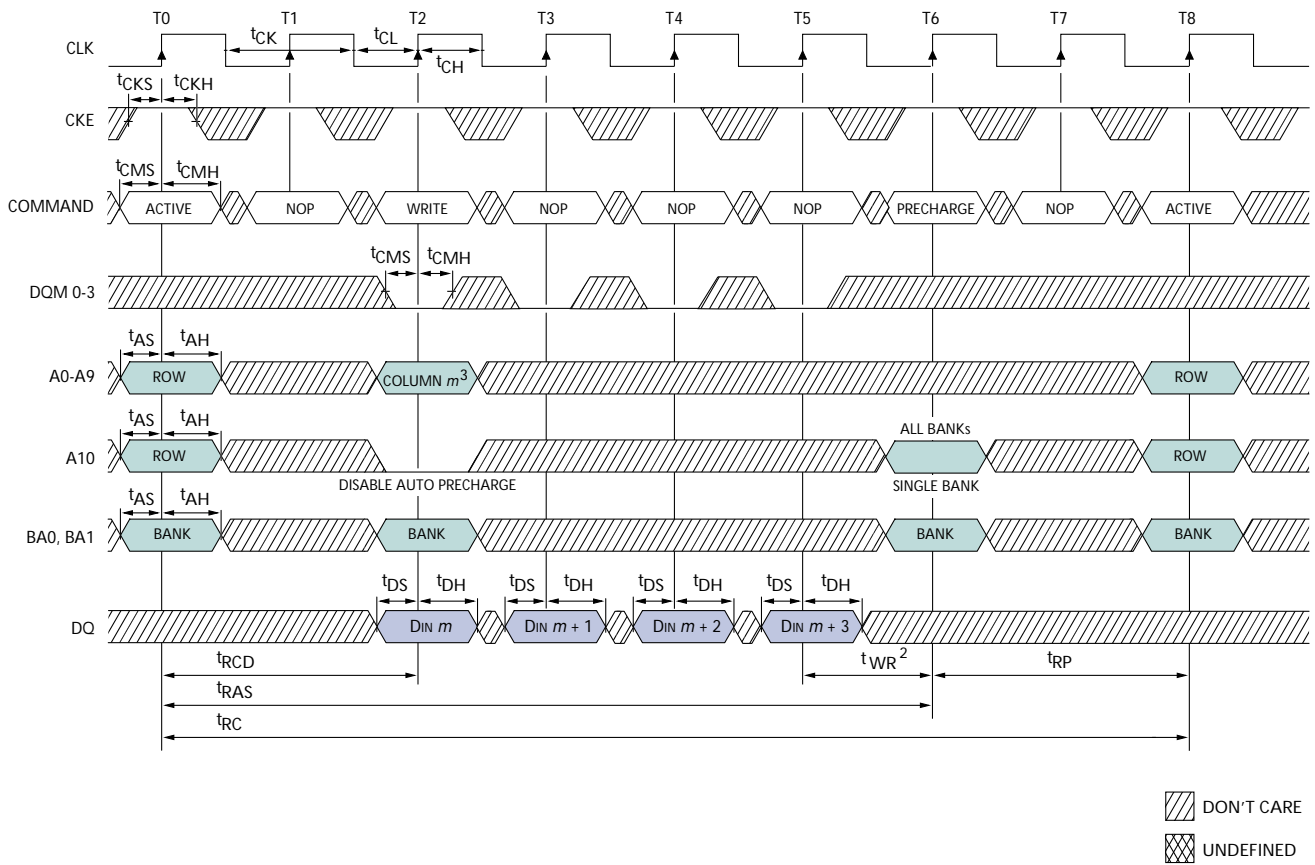
- Notes: 1. For this example, CL = 2.  
2. A8 and A9 = "Don't Care."

Figure 44: Single WRITE



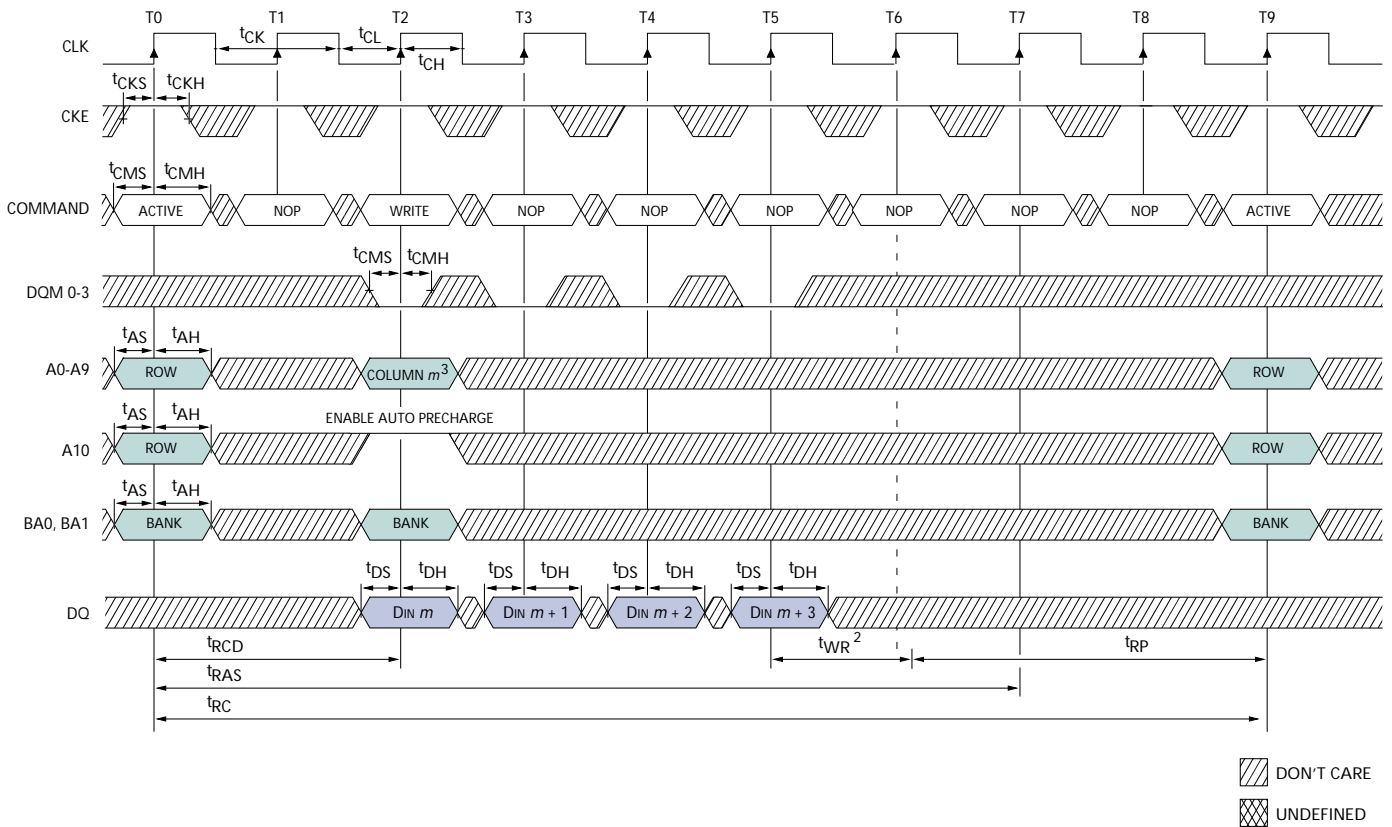
- Notes:
1. For this example, BL = 4, and the WRITE burst is followed by a "manual" PRECHARGE.
  2. 10ns is required between <DIN m> and the PRECHARGE command, regardless of frequency, to meet  $t_{WR}$ .
  3. A8 and A9 = "Don't Care."

Figure 45: WRITE – Without Auto Precharge



- Notes:
1. For this example, BL = 4, and the WRITE burst is followed by a “manual” PRECHARGE.
  2. Faster frequencies require two clocks (when  $t_{WR} > t_{CK}$ ).
  3. A8 and A9 = “Don’t Care.”
  4.  $t_{WR}$  of 1 CLK available if running 100 MHz or slower. Check factory for availability.

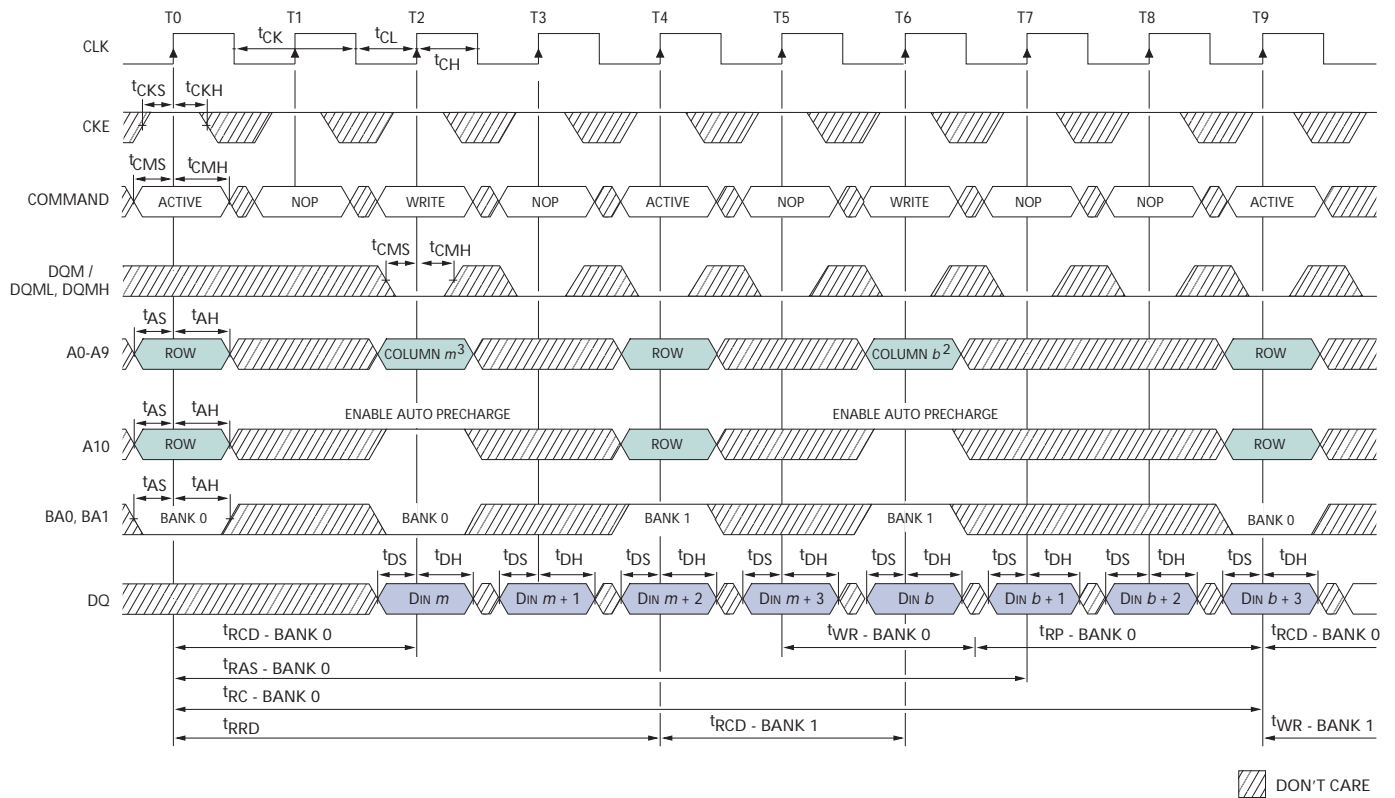
Figure 46: WRITE - with Auto Precharge



- Notes:
1. For this example, BL = 4.
  2. Faster frequencies require two clocks (when  $t_{WR} > t_{CK}$ ).
  3. A8 and A9 = "Don't Care."

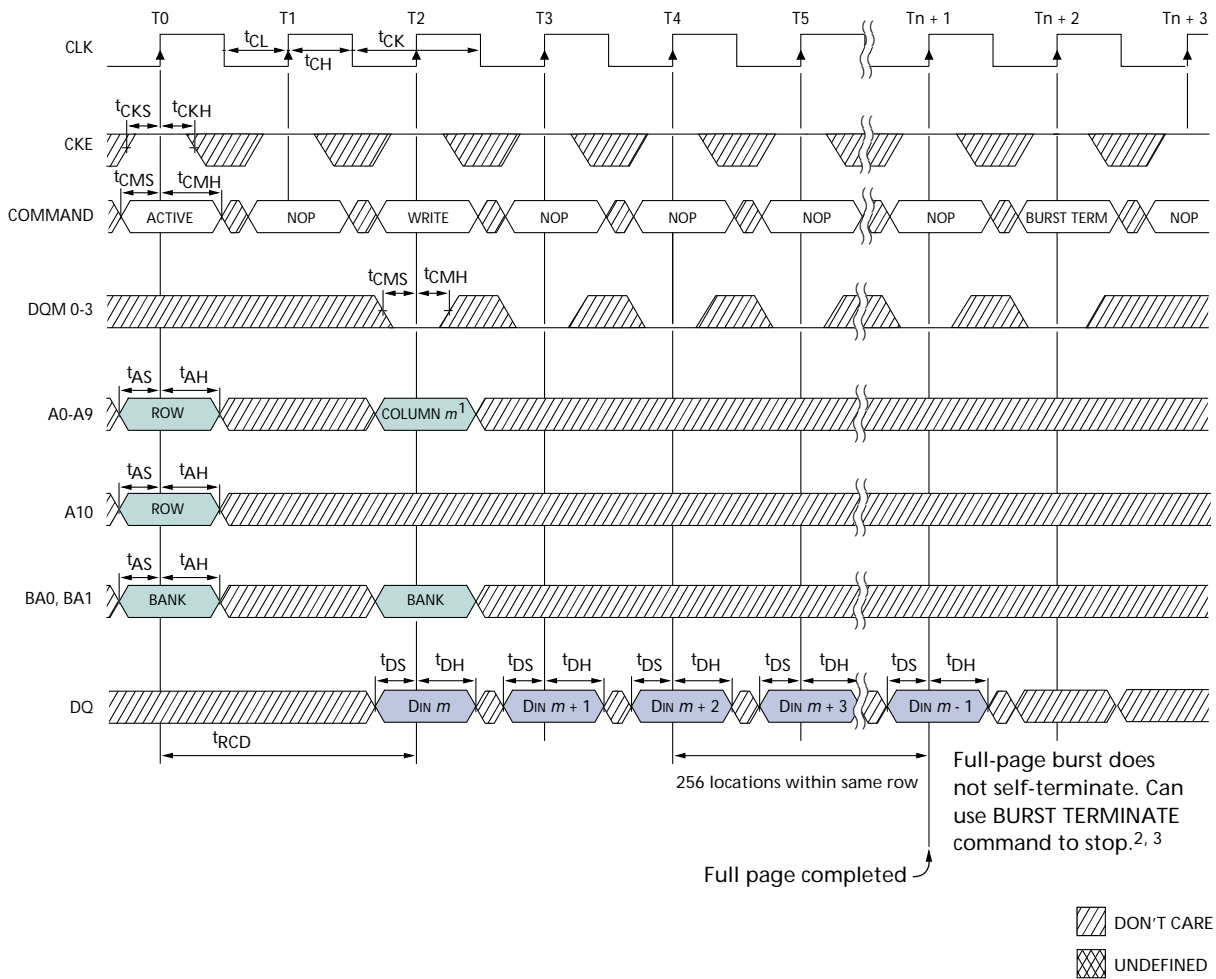


Figure 47: Alternating Write Accesses



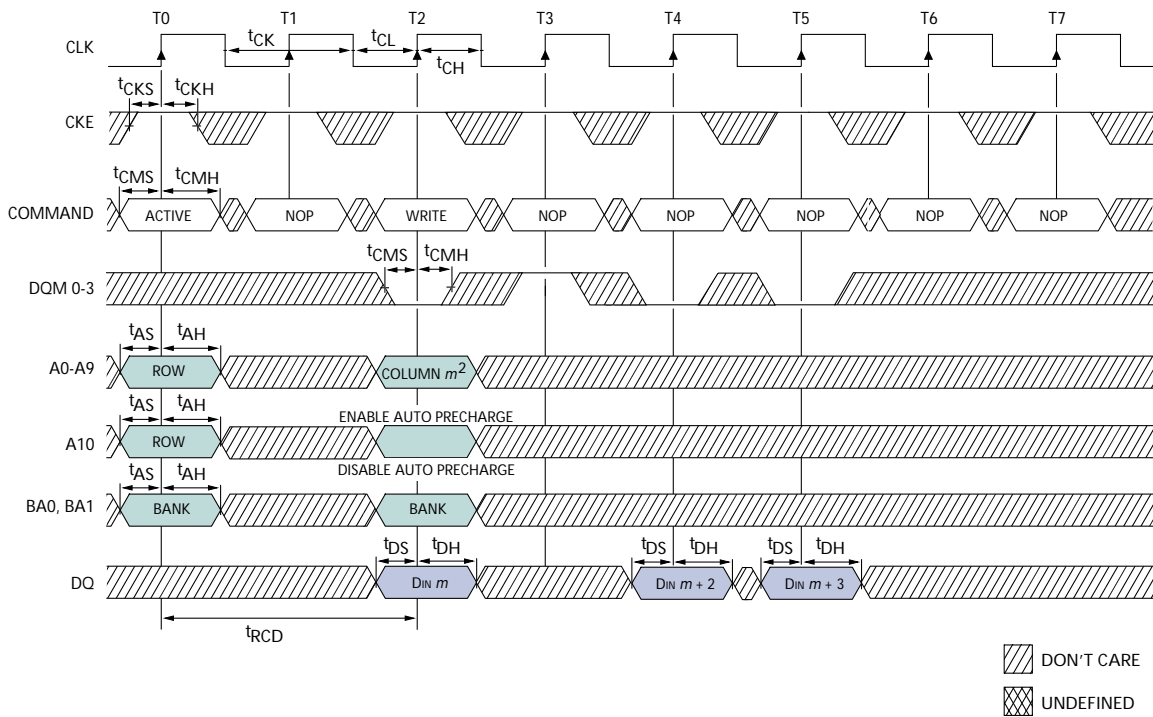
- Notes:
1. For this example, BL = 4.
  2. Faster frequencies require two clocks (when  $t_{WR} > t_{CK}$ ).
  3. A8 and A9 = "Don't Care."

Figure 48: WRITE – Full-Page Burst



- Notes:
1. A8 and A9 = "Don't Care."
  2.  $t_{WR}$  must be satisfied prior to PRECHARGE command.
  3. Page left open; no  $t_{RP}$ .

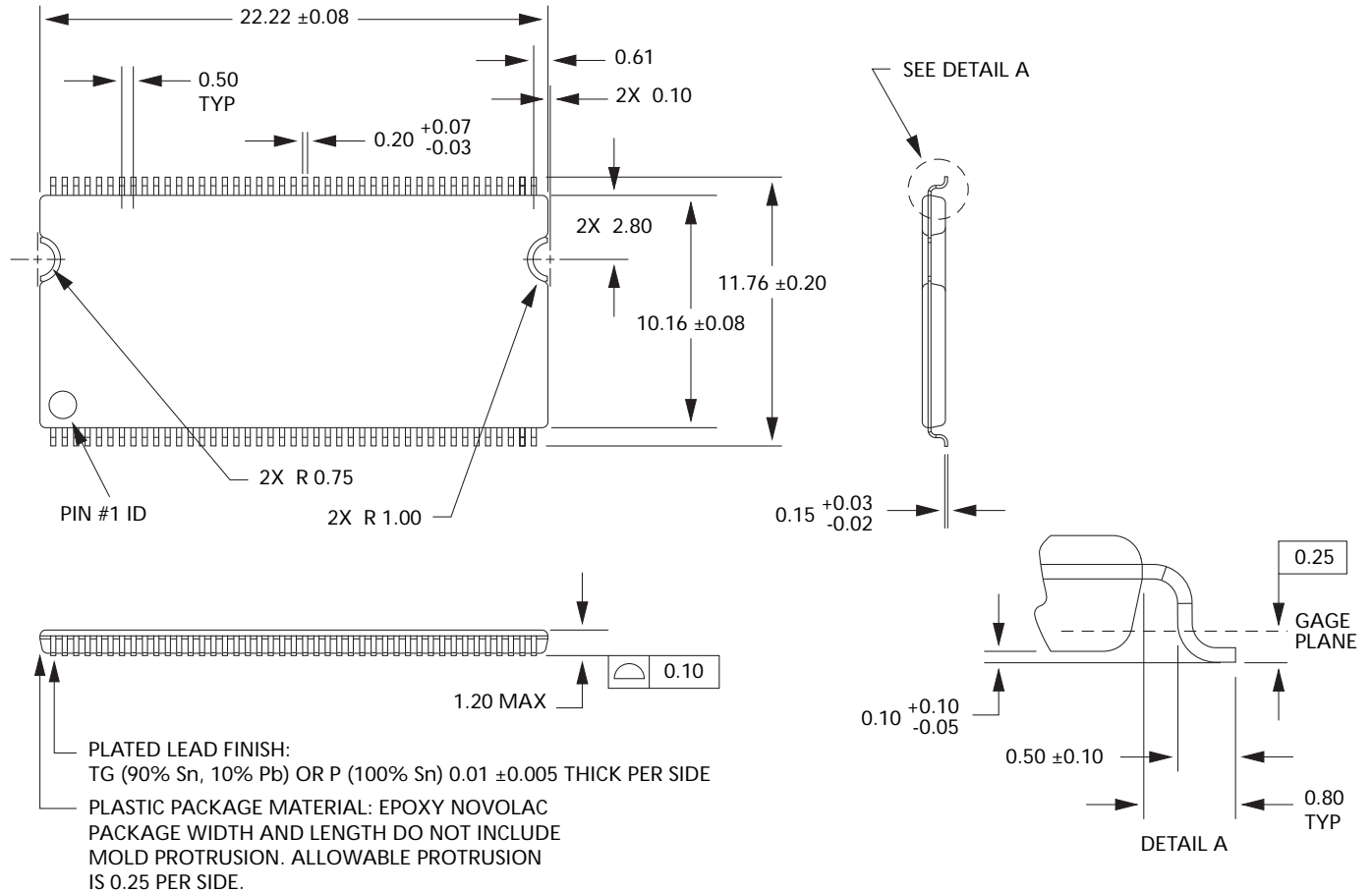
Figure 49: WRITE – DQM Operation



- Notes: 1. For this example, BL = 4.  
2. A8 and A9 = "Don't Care."

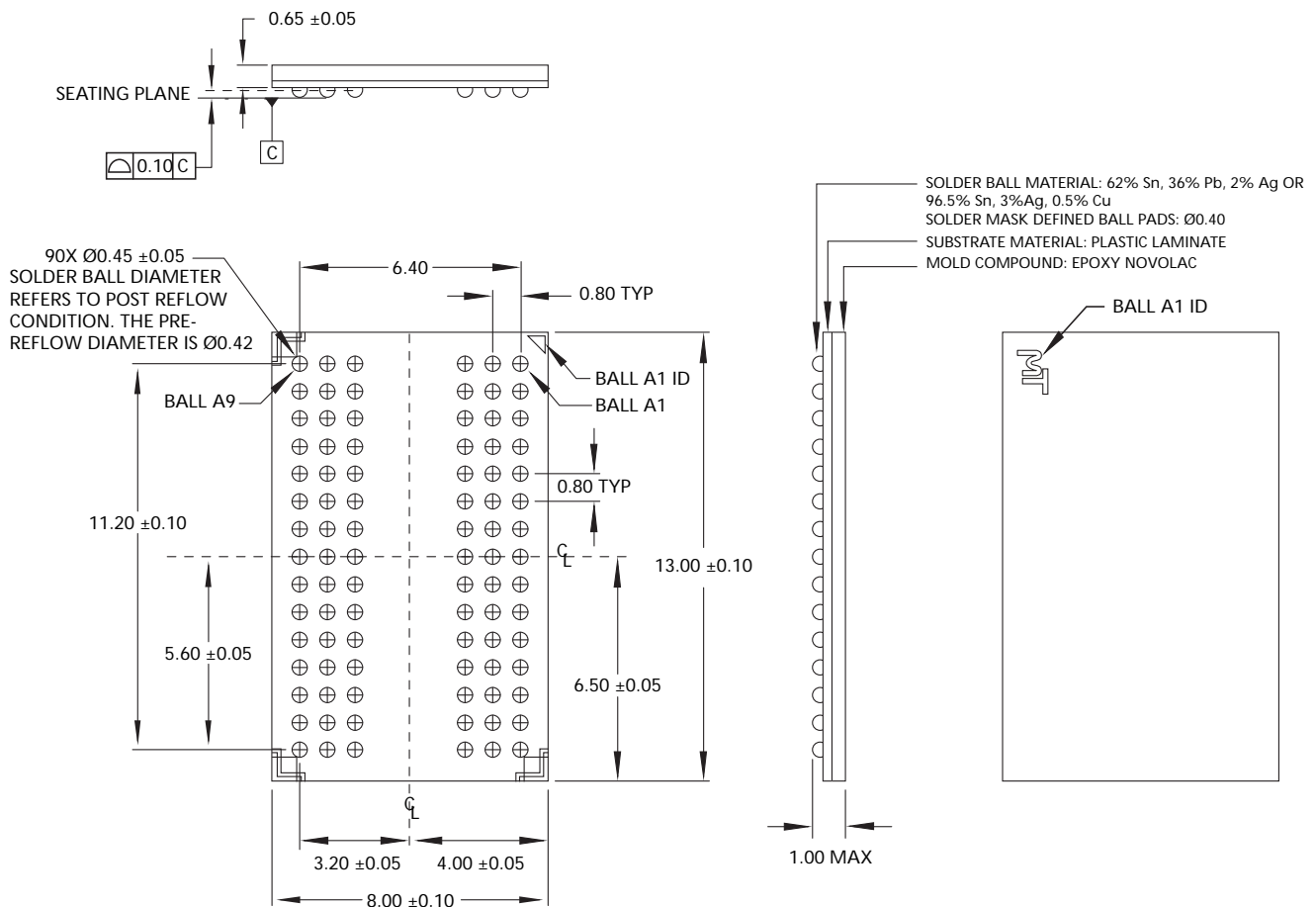
## Package Dimensions

Figure 50: 86-Pin Plastic TSOP II (400 mil)



- Notes:
1. All dimensions are in millimeters.
  2. Package width and length do not include mold protrusion; allowable mold protrusion is  $0.025$ mm per side.
  3. "2X" means the notch is present in two locations (both ends of the device).

Figure 51: 90-Ball VFBGA (8mm x 13mm)



- Notes:
1. All dimensions are in millimeters.
  2. Package width and length do not include mold protrusion; allowable mold protrusion is 0.025mm per side.
  3. Recommended pad size for PCB is 0.33mm ±0.025mm.
  4. Topside part marking decoder can be found at: [www.micron.com/support/designsupport/tools/fbga/decoder](http://www.micron.com/support/designsupport/tools/fbga/decoder).



8000 S. Federal Way, P.O. Box 6, Boise, ID 83707-0006, Tel: 208-368-3900  
 prodmtg@micron.com www.micron.com Customer Comment Line: 800-932-4992  
 Micron, the M logo, and the Micron logo are trademarks of Micron Technology, Inc.  
 All other trademarks are the property of their respective owners.

This data sheet contains minimum and maximum limits specified over the complete power supply and temperature range set forth herein. Although considered final, these specifications are subject to change, as further product development and data characterization sometimes occur.