

# DRAM

## MT4LC4M16R6, MT4LC4M16N3

For the latest data sheet, please refer to the Micron Web site: [www.micronsemi.com/mti/msp/html/datasheet.html](http://www.micronsemi.com/mti/msp/html/datasheet.html)

### FEATURES

- Single +3.3V ±0.3V power supply
- Industry-standard x16 pinout, timing, functions, and package
- 12 row, 10 column addresses (R6)  
13 row, 9 column addresses (N3)
- High-performance CMOS silicon-gate process
- All inputs, outputs and clocks are LVTTTL-compatible
- Extended Data-Out (EDO) PAGE MODE access
- 4,096-cycle CAS#-BEFORE-RAS# (CBR) REFRESH distributed across 64ms
- Optional self refresh (S) for low-power data retention

### OPTIONS

- Plastic Package  
50-pin TSOP (400 mil)
- Timing  
50ns access  
60ns access
- Refresh Rates  
4K  
8K  
Standard Refresh  
Self Refresh

### MARKING

TG  
-5  
-6  
R6  
N3  
None  
S\*  
None  
IT\*\*

- Operating Temperature Range  
Commercial (0°C to +70°C)  
Extended (-40°C to +85°C)

**NOTE:** 1. The "#" symbol indicates signal is active LOW.

\*Contact factory for availability.

\*\*Available only on MT4LC4M16R6 standard refresh device.

Part Number Example:  
**MT4LC4M16R6TG-5**

### KEY TIMING PARAMETERS

SPEED	t <sub>RC</sub>	t <sub>RAC</sub>	t <sub>PC</sub>	t <sub>AA</sub>	t <sub>CAC</sub>	t <sub>CAS</sub>
-5	84ns	50ns	20ns	25ns	13ns	8ns
-6	104ns	60ns	25ns	30ns	15ns	10ns

### PIN ASSIGNMENT (Top View)

#### 50-Pin TSOP

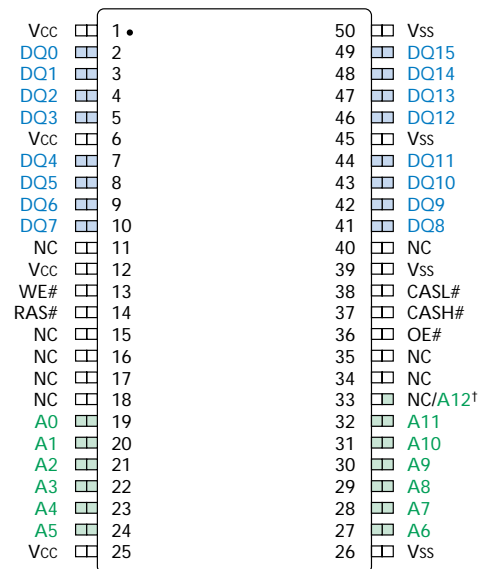

†A12 for N3 version, NC for R6 version.

	MT4LC4M16R6	MT4LC4M16N3
Configuration	4 Meg x 16	4 Meg x 16
Refresh	4K	8K
Row Address	4K (A0-A11)	8K (A0-A12)
Column Addressing	1K (A0-A9)	512 (A0-A8)

### 4 MEG x 16 EDO DRAM PART NUMBERS

PART NUMBER	REFRESH ADDRESSING	PACKAGE	REFRESH
MT4LC4M16R6TG-x	4K	400-TSOP	Standard
MT4LC4M16R6TG-x S	4K	400-TSOP	Self
MT4LC4M16N3TG-x	8K	400-TSOP	Standard
MT4LC4M16N3TG-x S	8K	400-TSOP	Self

x = speed

**FUNCTIONAL BLOCK DIAGRAM  
MT4LC4M16R6 (12 row addresses)**

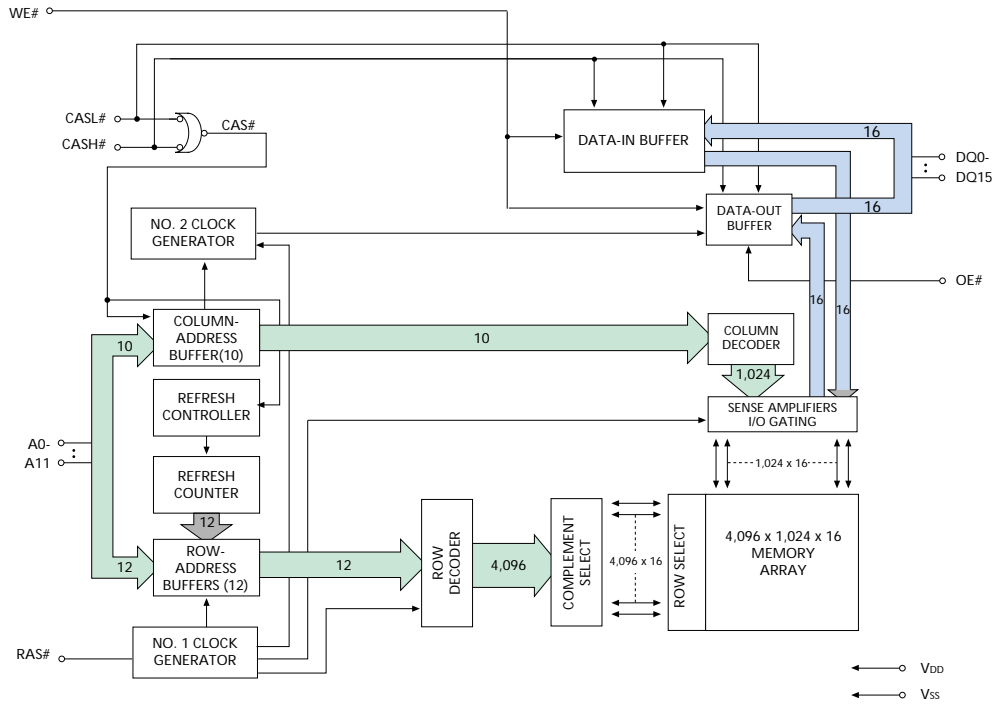

**FUNCTIONAL BLOCK DIAGRAM  
MT4LC4M16N3 (13 row addresses)**

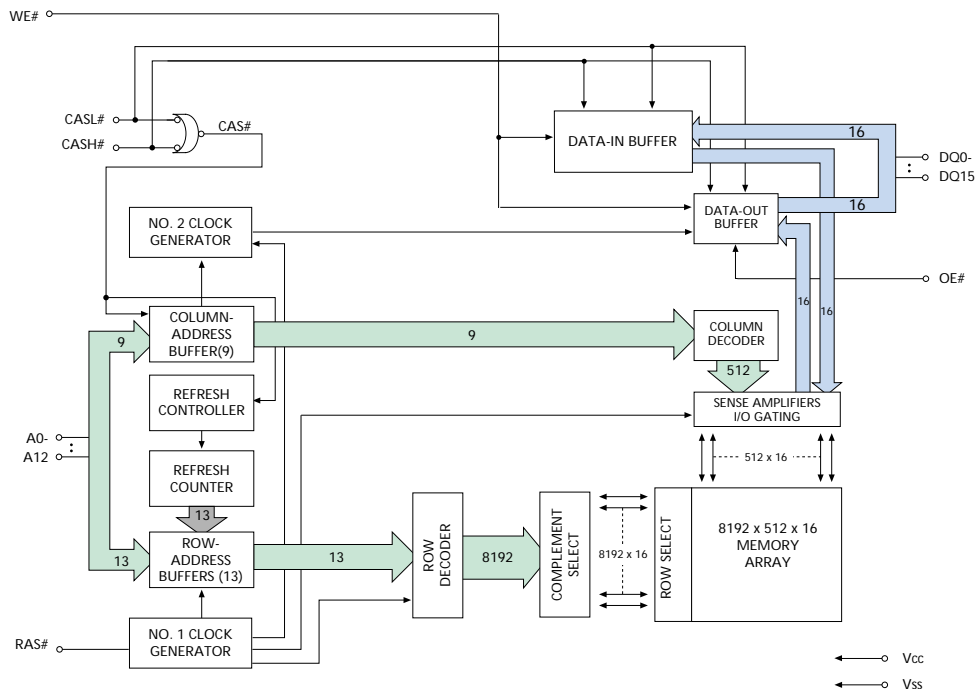

## GENERAL DESCRIPTION

The 4 Meg x 16 DRAM is a high-speed CMOS, dynamic random-access memory device containing 67,108,864 bits and designed to operate from 3V to 3.6V. The device is functionally organized as 4,194,304 locations containing 16 bits each. The 4,194,304 memory locations are arranged in 4,096 rows by 1,024 columns on the MT4LC4M16R6 or 8,192 rows by 512 columns on the MT4LC4M16N3. During READ or WRITE cycles, each location is uniquely addressed via the address bits: 12 row-address bits (A0-A11) and 10 column-address bits (A0-A9) on the MT4LC4M16R6 or 13 row-address bits (A0-A12) and 9 column-address bits (A0-A8) on the MT4LC4M16N3 version. In addition, both byte and word accesses are supported via the two CAS# pins (CASL# and CASH#).

The CAS# functionality and timing related to address and control functions (e.g., latching column addresses or selecting CBR REFRESH) is such that the internal CAS# signal is determined by the first external CAS# signal (CASL# or CASH#) to transition LOW and

the last to transition back HIGH. The CAS# functionality and timing related to driving or latching data is such that each CAS# signal independently controls the associated eight DQ pins.

The row address is latched by the RAS# signal, then the column address is latched by CAS#. This device provides EDO-PAGE-MODE operation, allowing for fast successive data operations (READ, WRITE or READ-MODIFY-WRITE) within a given row.

The 4 Meg x 16 DRAM must be refreshed periodically in order to retain stored data.

## DRAM ACCESS

Each location in the DRAM is uniquely addressable, as mentioned in the General Description. Use of both CAS# signals results in a word access via the 16 I/O pins (DQ0-DQ15). Using only one of the two signals results in a BYTE access cycle. CASL# transitioning LOW selects an access cycle for the lower byte (DQ0-DQ7), and CASH# transitioning LOW selects an access cycle for

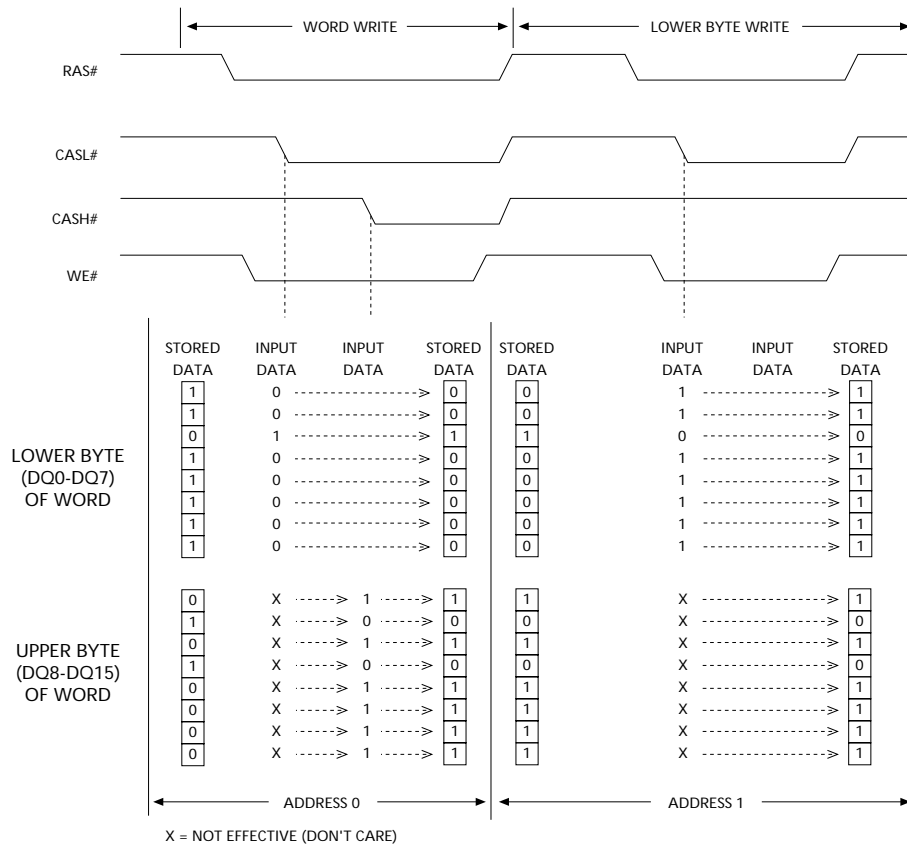

**Figure 1**  
**WORD and BYTE WRITE Example**

### DRAM ACCESS (continued)

the upper byte (DQ8-DQ15). General byte and word access timing is shown in Figures 1 and 2.

A logic HIGH on WE# dictates read mode, while a logic LOW on WE# dictates write mode. During a WRITE cycle, data-in (D) is latched by the falling edge of WE or CAS# (CASL# or CASH#), whichever occurs last. An EARLY WRITE occurs when WE is taken LOW prior to either CAS# falling. A LATE WRITE or READ-MODIFY-WRITE occurs when WE falls after CAS# (CASL# or CASH#) is taken LOW. During EARLY WRITE cycles, the data outputs (Q) will remain High-Z, regardless of the state of OE#. During LATE WRITE or READ-MODIFY-WRITE cycles, OE# must be taken HIGH to disable the data outputs prior to applying input data. If a LATE WRITE or READ-MODIFY-WRITE is attempted while keeping OE# LOW, no write will occur, and the data outputs will drive read data from the accessed location.

Additionally, both bytes must always be of the same mode of operation if both bytes are active. A CAS# precharge must be satisfied prior to changing modes of operation between the upper and lower bytes. For example, an EARLY WRITE on one byte and a LATE

WRITE on the other byte are not allowed during the same cycle. However, an EARLY WRITE on one byte and a LATE WRITE on the other byte, after a CAS# precharge has been satisfied, are permissible.

### EDO PAGE MODE

DRAM READ cycles have traditionally turned the output buffers off (High-Z) with the rising edge of CAS#. If CAS# went HIGH and OE# was LOW (active), the output buffers would be disabled. The 64Mb EDO DRAM offers an accelerated page mode cycle by eliminating output disable from CAS# HIGH. This option is called EDO, and it allows CAS# precharge time ( $t_{CP}$ ) to occur without the output data going invalid (see READ and EDO-PAGE-MODE READ waveforms).

EDO operates like any DRAM READ or FAST-PAGE-MODE READ, except data is held valid after CAS# goes HIGH, as long as RAS# and OE# are held LOW and WE# is held HIGH. OE# can be brought LOW or HIGH while CAS# and RAS# are LOW, and the DQs will transition between valid data and High-Z. Using OE#, there are

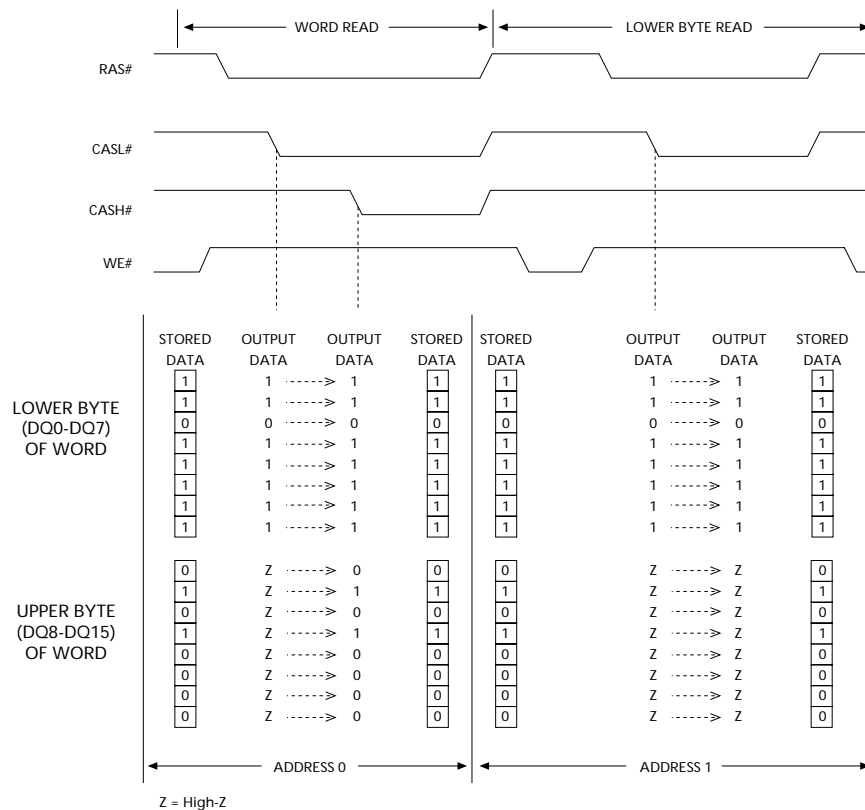

**Figure 2**  
**WORD and BYTE READ Example**

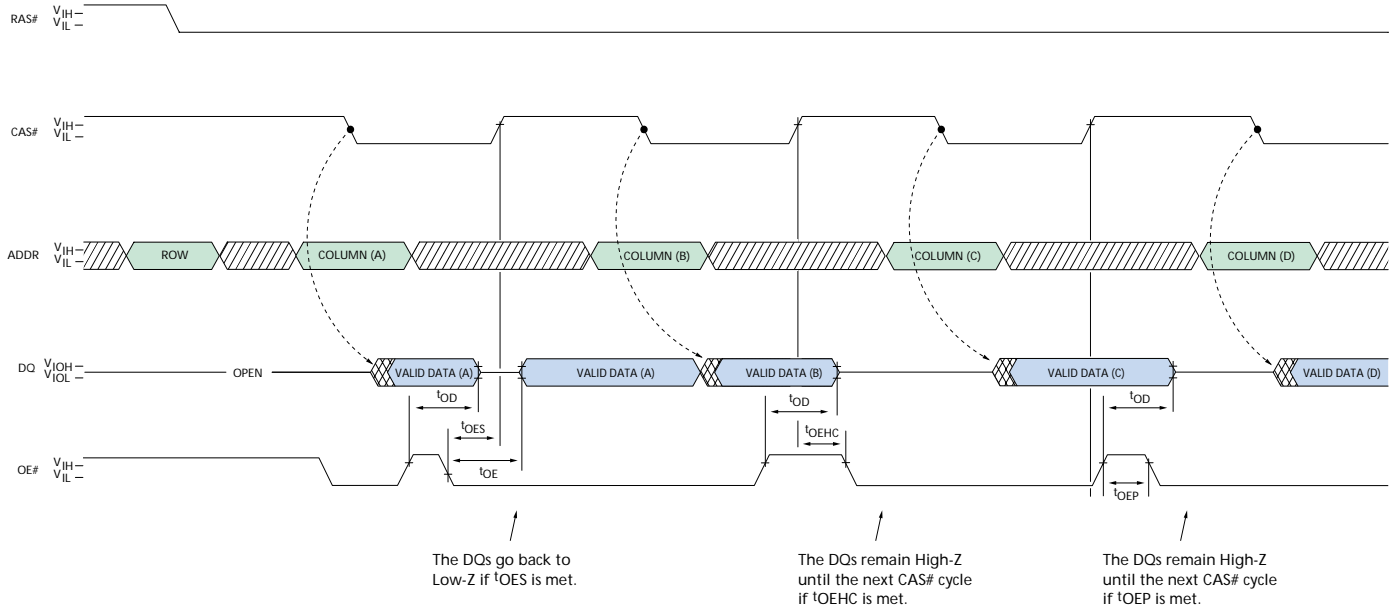

**Figure 3**  
**OE# Control of DQs**

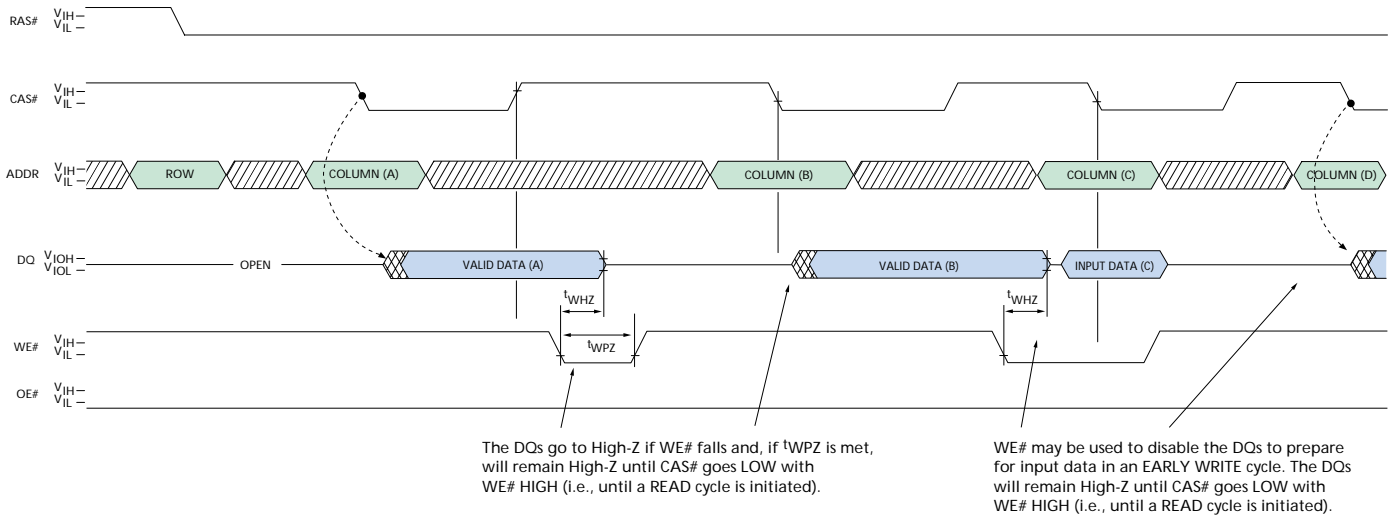

DON'T CARE  
 UNDEFINED

**Figure 4**  
**WE# Control of DQs**

## EDO PAGE MODE (continued)

two methods to disable the outputs and keep them disabled during the CAS# HIGH time. The first method is to have OE# HIGH when CAS# transitions HIGH and keep OE# HIGH for  $t_{OEHC}$  thereafter. This will disable the DQs, and they will remain disabled (regardless of the state of OE# after that point) until CAS# falls again. The second method is to have OE# LOW when CAS# transitions HIGH and then bring OE# HIGH for a minimum of  $t_{OEP}$  anytime during the CAS# HIGH period. This will disable the DQs, and they will remain disabled (regardless of the state of OE# after that point) until CAS# falls again (see Figure 3). During other cycles, the outputs are disabled at  $t_{OFF}$  time after RAS# and CAS# are HIGH or at  $t_{WHZ}$  after WE# transitions LOW. The  $t_{OFF}$  time is referenced from the rising edge of RAS# or CAS#, whichever occurs last. WE# can also perform the function of disabling the output drivers under certain conditions, as shown in Figure 4.

EDO-PAGE-MODE operations are always initiated with a row address strobed in by the RAS# signal, followed by a column address strobed in by CAS#, just like for single location accesses. However, subsequent column locations within the row may then be accessed at the page mode cycle time. This is accomplished by cycling CAS# while holding RAS# LOW and entering new column addresses with each CAS# cycle. Returning RAS# HIGH terminates the EDO-PAGE-MODE operation.

## DRAM REFRESH

The supply voltage must be maintained at the specified levels, and the refresh requirements must be met in order to retain stored data in the DRAM. The refresh requirements are met by refreshing all rows in the 4 Meg x 16 DRAM array at least once every 64ms (8,192

rows for N3 or 4,096 rows for R6). The recommended procedure is to execute 4,096 CBR REFRESH cycles, either uniformly spaced or grouped in bursts, every 64ms. The MT4LC4M16N3 internally refreshes two rows for each CBR cycle, whereas the MT4LC4M16R6 refreshes one row for every CBR cycle. For either device, executing 4,096 CBR cycles will refresh the entire device. The CBR REFRESH will invoke the internal refresh counter for automatic RAS# addressing. Alternatively, RAS#-ONLY REFRESH capability is inherently provided. However, with this method, only one row is refreshed on each cycle. Thus, 8,192 RAS-only REFRESH cycles are needed every 64ms on the MT4LC4M16N3 in order to refresh the entire device. JEDEC strongly recommends the use of CBR REFRESH for this device.

An optional self refresh mode is also available on the "S" version. The self refresh feature is initiated by performing a CBR Refresh cycle and holding RAS# low for the specified  $t_{RASS}$ . The "S" option allows the user the choice of a fully static, low-power data retention mode or a dynamic refresh mode at the extended refresh period of 128ms, or 31.25 $\mu$ s per cycle, when using a distributed CBR refresh. This refresh rate can be applied during normal operation, as well as during a standby or battery backup mode.

The self refresh mode is terminated by driving RAS# HIGH for a minimum time of  $t_{RPS}$ . This delay allows for the completion of any internal refresh cycles that may be in process at the time of the RAS# LOW-to-HIGH transition. If the DRAM controller uses a distributed CBR refresh sequence, a burst refresh is not required upon exiting self refresh, however, if the controller is using RAS# only or burst CBR refresh then a burst refresh using  $t_{RC}$  (MIN) is required.

**ABSOLUTE MAXIMUM RATINGS\***

Voltage on Vcc Relative to Vss.....	-1V to +4.6V
Voltage on NC, Inputs or I/O Pins	
Relative to Vss .....	-1V to +4.6V
Operating Temperature, T <sub>A</sub> (ambient)	
Commercial .....	0°C to +70°C
Extended (IT) .....	-40°C to +85°C**
Storage Temperature (plastic) .....	-55°C to +150°C
Power Dissipation .....	1W

\*Stresses greater than those listed under “Absolute Maximum Ratings” may cause permanent damage to the device. This is a stress rating only, and functional operation of the device at these or any other conditions above those indicated in the operational sections of this specification is not implied. Exposure to absolute maximum rating conditions for extended periods may affect reliability.

\*\*Available only on MT4LC4M16R6 standard refresh device.

**DC ELECTRICAL CHARACTERISTICS AND OPERATING CONDITIONS**

(Note: 1) (V<sub>CC</sub> = +3.3V ±0.3V)

PARAMETER/CONDITION	SYMBOL	MIN	MAX	UNITS	NOTES
SUPPLY VOLTAGE	V <sub>CC</sub>	3	3.6	V	
INPUT HIGH VOLTAGE: Valid Logic 1; All inputs, I/Os and any NC	V <sub>IH</sub>	2	V <sub>CC</sub> + 0.3	V	35
INPUT LOW VOLTAGE: Valid Logic 0; All inputs, I/Os and any NC	V <sub>IL</sub>	-0.3	0.8	V	35
INPUT LEAKAGE CURRENT: Any input at V <sub>IN</sub> (0V ≤ V <sub>IN</sub> ≤ V <sub>CC</sub> + 0.3V); All other pins not under test = 0V	I <sub>I</sub>	-2	2	μA	36
OUTPUT HIGH VOLTAGE: I <sub>OUT</sub> = -2mA	V <sub>OH</sub>	2.4	-	V	
OUTPUT LOW VOLTAGE: I <sub>OUT</sub> = 2mA	V <sub>OL</sub>	-	0.4	V	
OUTPUT LEAKAGE CURRENT: Any output at V <sub>OUT</sub> (0V ≤ V <sub>OUT</sub> ≤ V <sub>CC</sub> + 0.3V); DQ is disabled and in High-Z state	I <sub>OZ</sub>	-5	5	μA	

**I<sub>CC</sub> OPERATING CONDITIONS AND MAXIMUM LIMITS**

 (Notes: 1, 2, 3, 5, 6) ( $V_{CC} = +3.3V \pm 0.3V$ )

PARAMETER/CONDITION	SYMBOL	SPEED	MAX		UNITS	NOTES
			4K	8K		
STANDBY CURRENT: TTL (RAS# = CAS# = V <sub>IH</sub> )	I <sub>CC1</sub>	ALL	1	1	mA	
STANDBY CURRENT: CMOS (RAS# = CAS# ≥ V <sub>CC</sub> - 0.2V; DQs may be left open; Other inputs: V <sub>IN</sub> ≥ V <sub>CC</sub> - 0.2V or V <sub>IN</sub> ≤ 0.2V)	I <sub>CC2</sub>	ALL	500	500	μA	
OPERATING CURRENT: Random READ/WRITE Average power supply current (RAS#, CAS#, address cycling: t <sub>RC</sub> = t <sub>RC</sub> [MIN])	I <sub>CC3</sub>	-5 -6	150 165	115 130	mA	26
OPERATING CURRENT: EDO PAGE MODE Average power supply current (RAS# = V <sub>IL</sub> , CAS#, address cycling: t <sub>PC</sub> = t <sub>PC</sub> [MIN])	I <sub>CC4</sub>	-5 -6	120 125	120 125	mA	26
REFRESH CURRENT: RAS#-ONLY Average power supply current (RAS# cycling, CAS# = V <sub>IH</sub> : t <sub>RC</sub> = t <sub>RC</sub> [MIN])	I <sub>CC5</sub>	-5 -6	150 165	115 130	mA	22
REFRESH CURRENT: CBR Average power supply current (RAS#, CAS#, address cycling: t <sub>RC</sub> = t <sub>RC</sub> [MIN])	I <sub>CC6</sub>	-5 -6	150 165	150 165	mA	4, 7, 23
REFRESH CURRENT: Extended ("S" version only) Average power supply current: CAS# = 0.2V or CBR cycling; RAS# = t <sub>RAS</sub> (MIN); WE# = V <sub>CC</sub> - 0.2V; A0-A10, OE# and D <sub>IN</sub> = V <sub>CC</sub> - 0.2V or 0.2V (D <sub>IN</sub> may be left open); t <sub>RC</sub> = 125μs	I <sub>CC7</sub>	ALL	400	400	μA	4, 7, 23, 37
REFRESH CURRENT: Self ("S" version only) Average power supply current: CBR with RAS# ≥ t <sub>RASS</sub> (MIN) and CAS# held LOW; WE# = V <sub>CC</sub> - 0.2V; A0-A10, OE# and D <sub>IN</sub> = V <sub>CC</sub> - 0.2V or 0.2V (D <sub>IN</sub> may be left open)	I <sub>CC8</sub>	ALL	350	350	μA	4, 7, 37



## CAPACITANCE

(Note: 2)

PARAMETER	SYMBOL	MAX	UNITS
Input Capacitance: Address pins	C <sub>i1</sub>	5	pF
Input Capacitance: RAS#, CAS#, WE#, OE#	C <sub>i2</sub>	7	pF
Input/Output Capacitance: DQ	C <sub>io</sub>	7	pF

## AC ELECTRICAL CHARACTERISTICS

(Notes: 5, 6, 7, 8, 9, 10, 11, 12) (V<sub>CC</sub> = +3.3V ±0.3V)

AC CHARACTERISTICS PARAMETER	SYMBOL	-5		-6		UNITS	NOTES
		MIN	MAX	MIN	MAX		
Access time from column address	t <sub>AA</sub>		25		30	ns	
Column-address setup to CAS# precharge	t <sub>ACH</sub>	12		15		ns	
Column-address hold time (referenced to RAS#)	t <sub>AR</sub>	38		45		ns	
Column-address setup time	t <sub>ASC</sub>	0		0		ns	28
Row-address setup time	t <sub>ASR</sub>	0		0		ns	28
Column address to WE# delay time	t <sub>AWD</sub>	42		49		ns	18
Access time from CAS#	t <sub>CAC</sub>		13		15	ns	29
Column-address hold time	t <sub>CAH</sub>	8		10		ns	28
CAS# pulse width	t <sub>CAS</sub>	8	10,000	10	10,000	ns	30, 32
CAS# LOW to "Don't Care" during Self Refresh	t <sub>CHD</sub>	15		15		ns	
CAS# hold time (CBR Refresh)	t <sub>CHR</sub>	8		10		ns	4, 31
Last CAS# going LOW to first CAS# to return HIGH	t <sub>CLCH</sub>	5		5		ns	31
CAS# to output in Low-Z	t <sub>CLZ</sub>	0		0		ns	29
Data output hold after CAS# LOW	t <sub>COH</sub>	3		3		ns	
CAS# precharge time	t <sub>CP</sub>	8		10		ns	13, 33
Access time from CAS# precharge	t <sub>CPA</sub>		28		35	ns	29
CAS# to RAS# precharge time	t <sub>CRP</sub>	5		5		ns	31
CAS# hold time	t <sub>CSH</sub>	38		45		ns	31
CAS# setup time (CBR Refresh)	t <sub>CSR</sub>	5		5		ns	4, 28
CAS# to WE# delay time	t <sub>CWD</sub>	28		35		ns	18, 28
WRITE command to CAS# lead time	t <sub>CWL</sub>	8		10		ns	31
Data-in hold time	t <sub>DH</sub>	8		10		ns	19, 29
Data-in setup time	t <sub>DS</sub>	0		0		ns	19, 29
Output disable	t <sub>OD</sub>	0	12	0	15	ns	24, 25
Output enable time	t <sub>OE</sub>		12		15	ns	20
OE# hold time from WE# during READ-MODIFY-WRITE cycle	t <sub>OEH</sub>	8		10		ns	25
OE# HIGH hold time from CAS# HIGH	t <sub>OEHC</sub>	5		10		ns	
OE# HIGH pulse width	t <sub>OEP</sub>	5		5		ns	
OE# LOW to CAS# HIGH setup time	t <sub>OES</sub>	4		5		ns	
Output buffer turn-off delay	t <sub>OFF</sub>	0	12	0	15	ns	17, 24, 29
OE# setup prior to RAS# during HIDDEN REFRESH cycle	t <sub>ORD</sub>	0		0		ns	

**AC ELECTRICAL CHARACTERISTICS**

 (Notes: 5, 6, 7, 8, 9, 10, 11, 12) ( $V_{CC} = +3.3V \pm 0.3V$ )

AC CHARACTERISTICS		-5		-6			
PARAMETER	SYMBOL	MIN	MAX	MIN	MAX	UNITS	NOTES
EDO-PAGE-MODE READ or WRITE cycle time	$t_{PC}$	20		25		ns	34
EDO-PAGE-MODE READ-WRITE cycle time	$t_{PRWC}$	47		56		ns	34
Access time from RAS#	$t_{RAC}$		50		60	ns	
RAS# to column-address delay time	$t_{RAD}$	9		12		ns	15
Row address hold time	$t_{RAH}$	7		10		ns	
RAS# pulse width	$t_{RAS}$	50	10,000	60	10,000	ns	
RAS# pulse width (EDO PAGE MODE)	$t_{RASP}$	50	125,000	60	125,000	ns	
RAS# pulse width during Self Refresh	$t_{RASS}$	100		100		$\mu s$	
Random READ or WRITE cycle time	$t_{RC}$	84		104		ns	
RAS# to CAS# delay time	$t_{RCD}$	11		14		ns	14, 28
READ command hold time (referenced to CAS#)	$t_{RCH}$	0		0		ns	16, 30
READ command setup time	$t_{RCS}$	0		0		ns	28
Refresh period	$t_{REF}$		64		64	ms	22, 23
Refresh period ("S" version)	$t_{REF}$		128		128	ms	23
RAS# precharge time	$t_{RP}$	30		40		ns	
RAS# to CAS# precharge time	$t_{RPC}$	5		5		ns	
RAS# precharge time exiting Self Refresh	$t_{RPS}$	90		105		ns	
READ command hold time (referenced to RAS#)	$t_{RRH}$	0		0		ns	16
RAS# hold time	$t_{RSH}$	13		15		ns	35
READ-WRITE cycle time	$t_{RWC}$	116		140		ns	
RAS# to WE# delay time	$t_{RWD}$	67		79		ns	18
WRITE command to RAS# lead time	$t_{RWL}$	13		15		ns	
Transition time (rise or fall)	$t_T$	2	50	2	50	ns	
WRITE command hold time	$t_{WCH}$	8		10		ns	35
WRITE command hold time (referenced to RAS#)	$t_{WCR}$	38		45		ns	
WE# command setup time	$t_{WCS}$	0		0		ns	18, 28
WE# to outputs in High-Z	$t_{WHZ}$		12		15	ns	
WRITE command pulse width	$t_{WP}$	5		5		ns	
WE# pulse widths to disable outputs	$t_{WPZ}$	10		10		ns	
WE# hold time (CBR Refresh)	$t_{WRH}$	8		10		ns	
WE# setup time (CBR Refresh)	$t_{WRP}$	8		10		ns	

**NOTES**

1. All voltages referenced to  $V_{SS}$ .
2. This parameter is sampled.  $V_{CC} = +3.3V$ ;  $f = 1$  MHz;  $T_A = 25^\circ C$ .
3.  $I_{CC}$  is dependent on output loading and cycle rates. Specified values are obtained with minimum cycle time and the outputs open.
4. Enables on-chip refresh and address counters.
5. The minimum specifications are used only to indicate cycle time at which proper operation over the full temperature range is ensured.
6. An initial pause of 100 $\mu s$  is required after power-up, followed by eight RAS# refresh cycles (RAS#-ONLY or CBR with WE# HIGH), before proper device operation is ensured. The eight RAS# cycle wake-ups should be repeated any time the  $t_{REF}$  refresh requirement is exceeded.
7. AC characteristics assume  $t_T = 2.5ns$ .
8.  $V_{IH}$  (MIN) and  $V_{IL}$  (MAX) are reference levels for measuring timing of input signals. Transition times are measured between  $V_{IH}$  and  $V_{IL}$  (or between  $V_{IL}$  and  $V_{IH}$ ).
9. In addition to meeting the transition rate specification, all input signals must transit between  $V_{IH}$  and  $V_{IL}$  (or between  $V_{IL}$  and  $V_{IH}$ ) in a monotonic manner.
10. If CAS# and RAS# =  $V_{IH}$ , data output is High-Z.
11. If CAS# =  $V_{IL}$ , data output may contain data from the last valid READ cycle.
12. Measured with a load equivalent to two TTL gates and 100pF; and  $V_{OL} = 0.8V$  and  $V_{OH} = 2V$ .
13. If CAS# is LOW at the falling edge of RAS#, output data will be maintained from the previous cycle. To initiate a new cycle and clear the data-out buffer, CAS# must be pulsed HIGH for  $t_{CP}$ .
14. The  $t_{RCD}$  (MAX) limit is no longer specified.  $t_{RCD}$  (MAX) was specified as a reference point only. If  $t_{RCD}$  was greater than the specified  $t_{RCD}$  (MAX) limit, then access time was controlled exclusively by  $t_{CAC}$  ( $t_{RAC}$  [MIN] no longer applied). With or without the  $t_{RCD}$  limit,  $t_{AA}$  and  $t_{CAC}$  must always be met.
15. The  $t_{RAD}$  (MAX) limit is no longer specified.  $t_{RAD}$  (MAX) was specified as a reference point only. If  $t_{RAD}$  was greater than the specified  $t_{RAD}$  (MAX) limit, then access time was controlled exclusively by  $t_{AA}$  ( $t_{RAC}$  and  $t_{CAC}$  no longer applied). With or without the  $t_{RAD}$  (MAX) limit,  $t_{AA}$ ,  $t_{RAC}$ , and  $t_{CAC}$  must always be met.
16. Either  $t_{RCH}$  or  $t_{RRH}$  must be satisfied for a READ cycle.
17.  $t_{OFF}$  (MAX) defines the time at which the output achieves the open circuit condition and is not referenced to  $V_{OH}$  or  $V_{OL}$ .
18.  $t_{WCS}$ ,  $t_{RWD}$ ,  $t_{AWD}$ , and  $t_{CWD}$  are not restrictive operating parameters.  $t_{WCS}$  applies to EARLY WRITE cycles. If  $t_{WCS} > t_{WCS}$  (MIN), the cycle is an EARLY WRITE cycle and the data output will remain an open circuit throughout the entire cycle.  $t_{RWD}$ ,  $t_{AWD}$ , and  $t_{CWD}$  define READ-MODIFY-WRITE cycles. Meeting these limits allows for reading and disabling output data and then applying input data. OE# held HIGH and WE# taken LOW after CAS# goes LOW results in a LATE WRITE (OE#-controlled) cycle.  $t_{WCS}$ ,  $t_{RWD}$ ,  $t_{CWD}$ , and  $t_{AWD}$  are not applicable in a LATE WRITE cycle.
19. These parameters are referenced to CAS# leading edge in EARLY WRITE cycles and WE# leading edge in LATE WRITE or READ-MODIFY-WRITE cycles.
20. If OE# is tied permanently LOW, LATE WRITE, or READ-MODIFY-WRITE operations are not possible.
21. A HIDDEN REFRESH may also be performed after a WRITE cycle. In this case, WE# is LOW and OE# is HIGH.
22. RAS#-ONLY REFRESH requires that all 8,192 rows of the MT4LC4M16N3 or all 4,096 rows of the MT4LC4M16R6 be refreshed at least once every 64ms.
23. CBR REFRESH for either device requires that at least 4,096 cycles be completed every 64ms.
24. The DQs go High-Z during READ cycles once  $t_{OD}$  or  $t_{OFF}$  occur. If CAS# stays LOW while OE# is brought HIGH, the DQs will go High-Z. If OE# is brought back LOW (CAS# still LOW), the DQs will provide the previously read data.
25. LATE WRITE and READ-MODIFY-WRITE cycles must have both  $t_{OD}$  and  $t_{OE}$  met (OE# HIGH during WRITE cycle) in order to ensure that the output buffers will be open during the WRITE cycle. If OE# is taken back LOW while CAS# remains LOW, the DQs will remain open.
26. Column address changed once each cycle.
27. The first CASx# edge to transition LOW.

**NOTES (continued)**

28. Output parameter (DQx) is referenced to corresponding CAS# input; DQ0-DQ7 by CASL# and DQ8-DQ15 by CASH#.
29. Each CASx# must meet minimum pulse width.
30. The last CASx# edge to transition HIGH.
31. Last falling CASx# edge to first rising CASx# edge.
32. Last rising CASx# edge to first falling CASx# edge.
33. Last rising CASx# edge to next cycle's last rising CASx# edge.
34. Last CASx# to go LOW.
35.  $V_{IH}$  overshoot:  $V_{IH} (MAX) = V_{CC} + 2V$  for a pulse width  $\leq 3ns$ , and the pulse width cannot be greater than one third of the cycle rate.  $V_{IL}$  undershoot:  $V_{IL} (MIN) = -2V$  for a pulse width  $\leq 3ns$ , and the pulse width cannot be greater than one third of the cycle rate.
36. NC pins are assumed to be left floating and are not tested for leakage.
37. Self refresh and extended refresh for either device requires that at least 4,096 cycles be completed every 128ms.

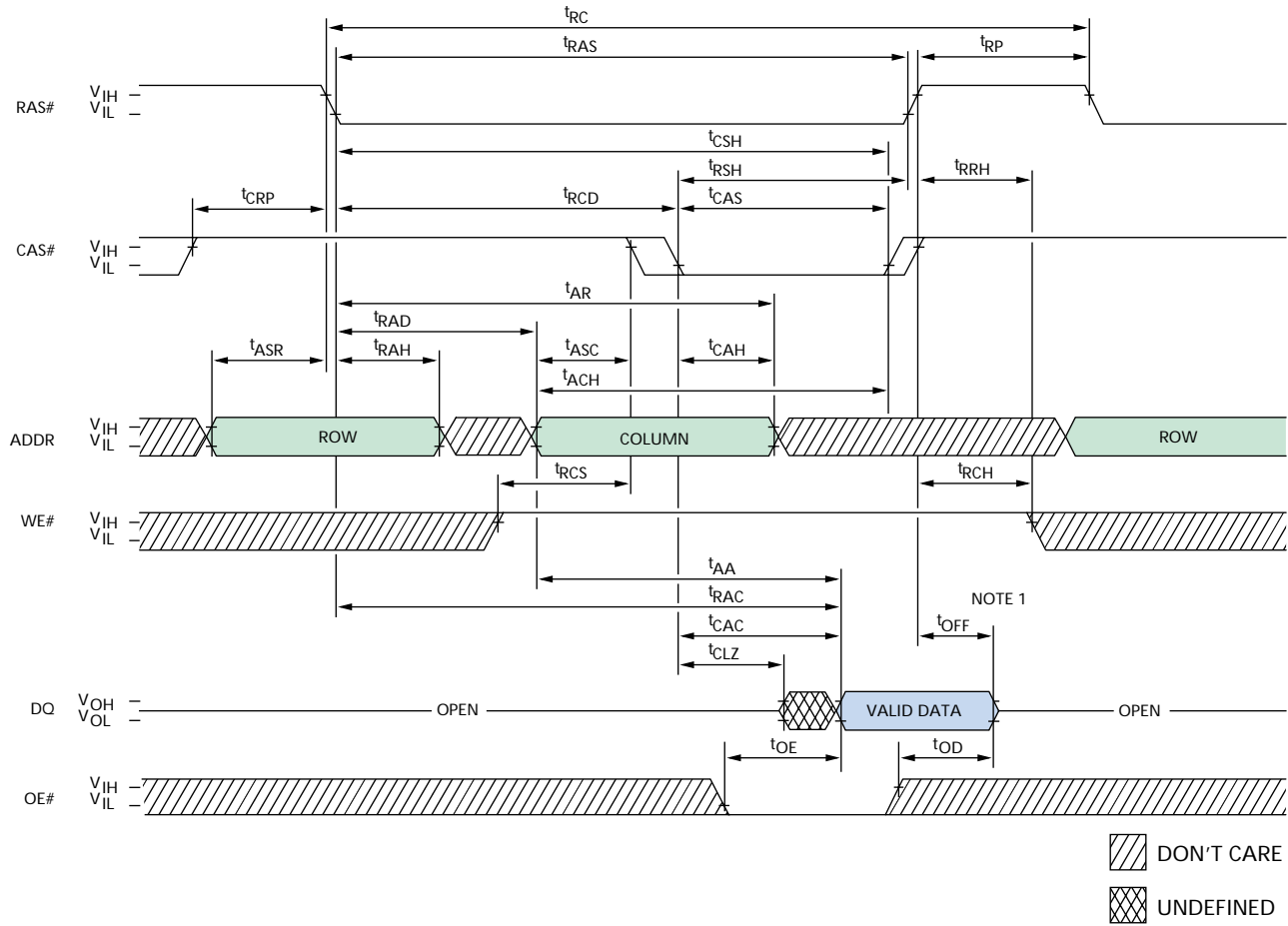
**READ CYCLE**

**TIMING PARAMETERS**

SYMBOL	-5		-6		UNITS
	MIN	MAX	MIN	MAX	
t <sub>AA</sub>		25		30	ns
t <sub>ACH</sub>	12		15		ns
t <sub>AR</sub>	38		45		ns
t <sub>ASC</sub>	0		0		ns
t <sub>ASR</sub>	0		0		ns
t <sub>CAC</sub>		13		15	ns
t <sub>CAH</sub>	8		10		ns
t <sub>CAS</sub>	8	10,000	10	10,000	ns
t <sub>CLCH</sub>	5		5		ns
t <sub>CLZ</sub>	0		0		ns
t <sub>CRP</sub>	5		5		ns
t <sub>CSH</sub>	38		45		ns
t <sub>OD</sub>	0	12	0	15	ns

SYMBOL	-5		-6		UNITS
	MIN	MAX	MIN	MAX	
t <sub>OE</sub>		12		15	ns
t <sub>OFF</sub>	0	12	0	15	ns
t <sub>RAC</sub>		50		60	ns
t <sub>RAD</sub>	9		12		ns
t <sub>RAH</sub>	7		10		ns
t <sub>RAS</sub>	50	10,000	60	10,000	ns
t <sub>RC</sub>	84		104		ns
t <sub>RCD</sub>	11		14		ns
t <sub>RCH</sub>	0		0		ns
t <sub>RCS</sub>	0		0		ns
t <sub>RP</sub>	30		40		ns
t <sub>RRH</sub>	0		0		ns
t <sub>RSH</sub>	13		15		ns

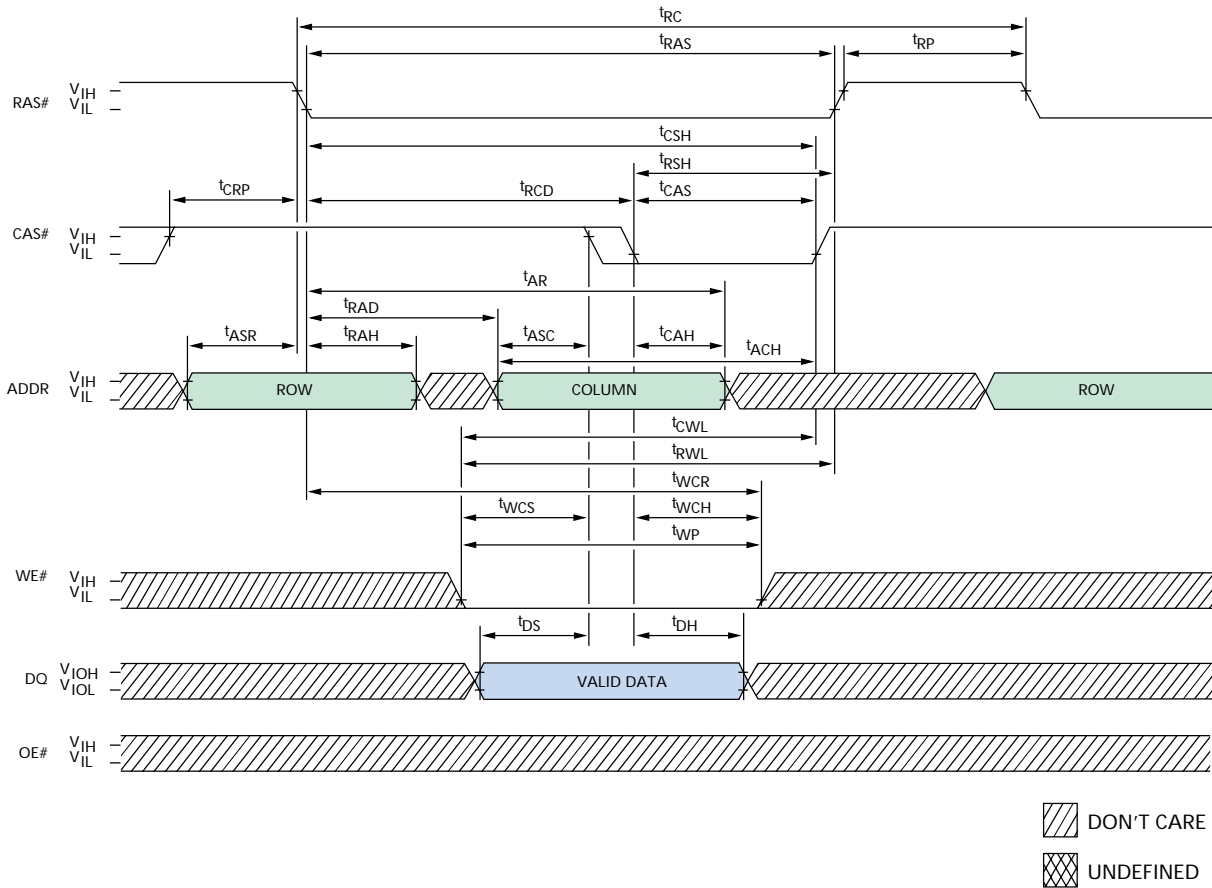
**NOTE:** 1. t<sub>OFF</sub> is referenced from rising edge of RAS# or CAS#, whichever occurs last.

**EARLY WRITE CYCLE**

**TIMING PARAMETERS**

SYMBOL	-5		-6		UNITS
	MIN	MAX	MIN	MAX	
$t_{ACH}$	12		15		ns
$t_{AR}$	38		45		ns
$t_{ASC}$	0		0		ns
$t_{ASR}$	0		0		ns
$t_{CAH}$	8		10		ns
$t_{CAS}$	8	10,000	10	10,000	ns
$t_{CLCH}$	5		5		ns
$t_{CRP}$	5		5		ns
$t_{CSH}$	38		45		ns
$t_{CWL}$	8		10		ns
$t_{DH}$	8		10		ns
$t_{DS}$	0		0		ns

SYMBOL	-5		-6		UNITS
	MIN	MAX	MIN	MAX	
$t_{RAD}$	9		12		ns
$t_{RAH}$	7		10		ns
$t_{RAS}$	50	10,000	60	10,000	ns
$t_{RC}$	84		104		ns
$t_{RCD}$	11		14		ns
$t_{RP}$	30		40		ns
$t_{RSH}$	13		15		ns
$t_{RWL}$	13		15		ns
$t_{WCH}$	8		10		ns
$t_{WCR}$	38		45		ns
$t_{WCS}$	0		0		ns
$t_{WP}$	5		5		ns

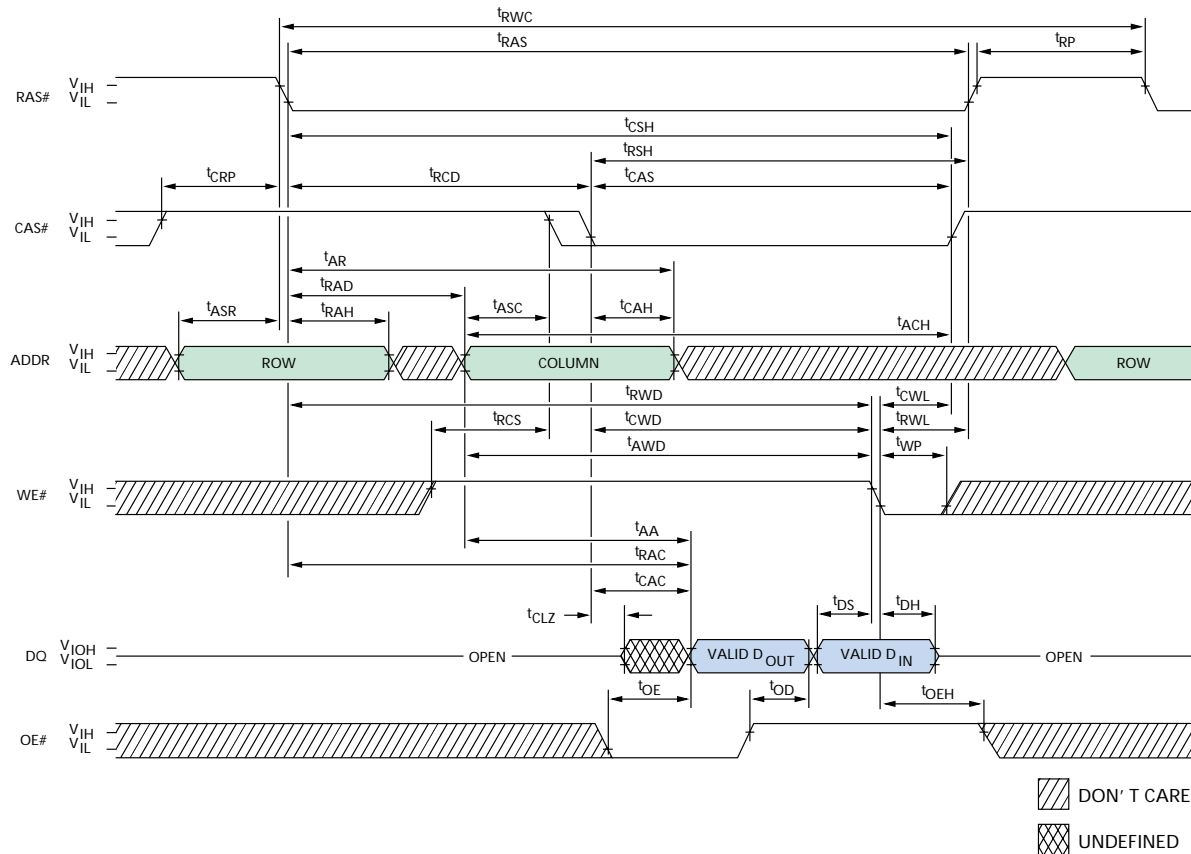
## READ-WRITE CYCLE (LATE WRITE and READ-MODIFY-WRITE cycles)



### TIMING PARAMETERS

SYMBOL	-5		-6		UNITS
	MIN	MAX	MIN	MAX	
$t_{AA}$		25		30	ns
$t_{ACH}$	12		15		ns
$t_{AR}$	38		45		ns
$t_{ASC}$	0		0		ns
$t_{ASR}$	0		0		ns
$t_{AWD}$	42		49		ns
$t_{CAC}$		13		15	ns
$t_{CAH}$	8		10		ns
$t_{CAS}$	8	10,000	10	10,000	ns
$t_{CLCH}$	5		5		ns
$t_{CLZ}$	0		0		ns
$t_{CRP}$	5		5		ns
$t_{CSH}$	38		45		ns
$t_{CWD}$	28		35		ns
$t_{CWL}$	8		10		ns
$t_{DH}$	8		10		ns

SYMBOL	-5		-6		UNITS
	MIN	MAX	MIN	MAX	
$t_{DS}$	0		0		ns
$t_{OD}$	0	12	0	15	ns
$t_{OE}$		12		15	ns
$t_{OEH}$	8		10		ns
$t_{RAC}$		50		60	ns
$t_{RAD}$	9		12		ns
$t_{RAH}$	7		10		ns
$t_{RAS}$	50	10,000	60	10,000	ns
$t_{RCD}$	11		14		ns
$t_{RCS}$	0		0		ns
$t_{RP}$	30		40		ns
$t_{RSH}$	13		15		ns
$t_{RWC}$	116		140		ns
$t_{RWD}$	67		79		ns
$t_{RWL}$	13		15		ns
$t_{WP}$	5		5		ns

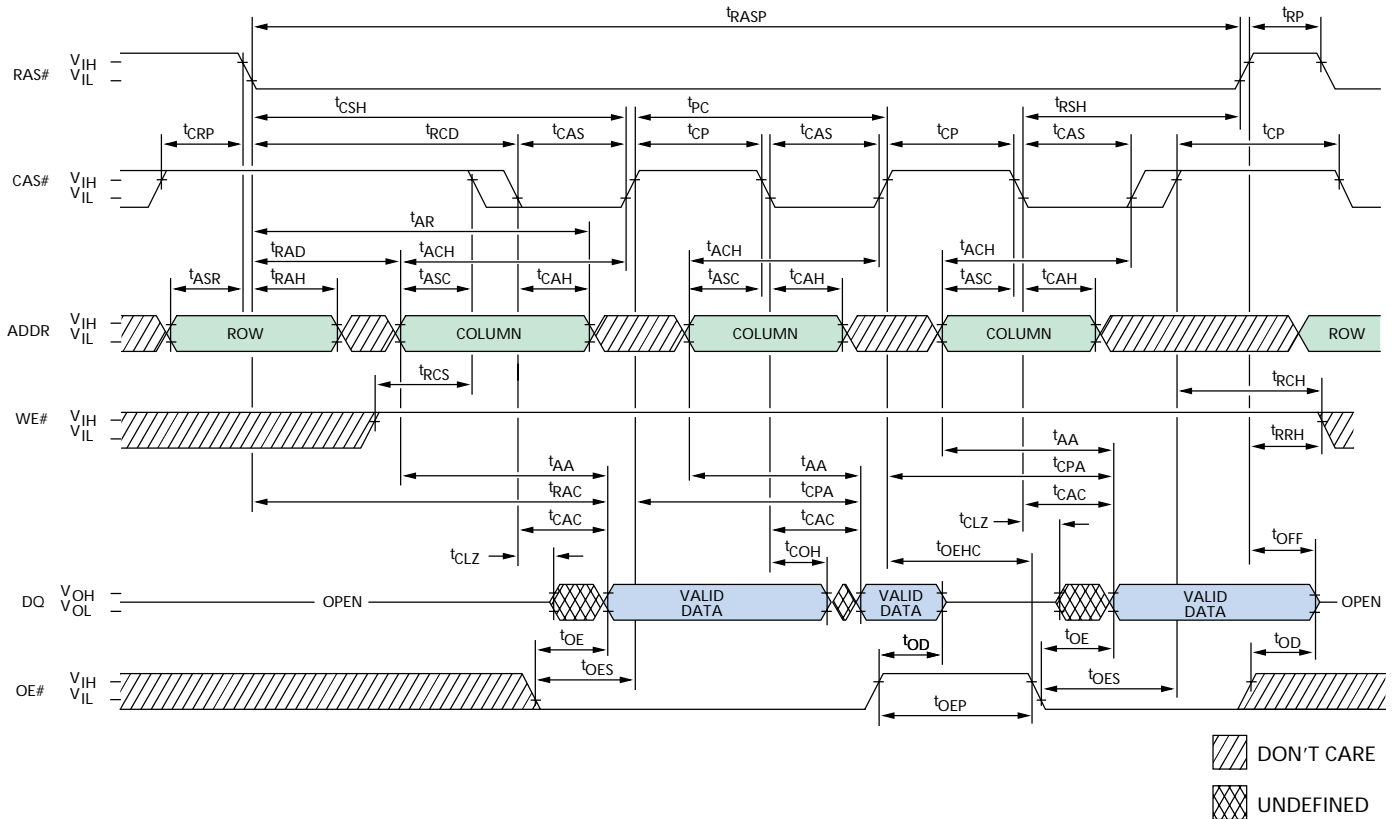
**EDO-PAGE-MODE READ CYCLE**

**TIMING PARAMETERS**

SYMBOL	-5		-6		UNITS
	MIN	MAX	MIN	MAX	
tAA		25		30	ns
tACH	12		15		ns
tAR	38		45		ns
tASC	0		0		ns
tASR	0		0		ns
tCAC		13		15	ns
tCAH	8		10		ns
tCAS	8	10,000	10	10,000	ns
tCLCH	5		5		ns
tCLZ	0		0		ns
tCOH	3		3		ns
tCP	8		10		ns
tCPA		28		35	ns
tCRP	5		5		ns
tCSH	38		45		ns
tOD	0	12	0	15	ns

SYMBOL	-5		-6		UNITS
	MIN	MAX	MIN	MAX	
tOE		12		15	ns
tOEHC	5		10		ns
tOEP	5		5		ns
tOES	4		5		ns
tOFF	0	12	0	15	ns
tPC	20		25		ns
tRAC		50		60	ns
tRAD	9		12		ns
tRAH	7		10		ns
tRASP	50	125,000	60	125,000	ns
tRCD	11		14		ns
tRCH	0		0		ns
tRCS	0		0		ns
tRP	30		40		ns
tRRH	0		0		ns
tRSH	13		15		ns

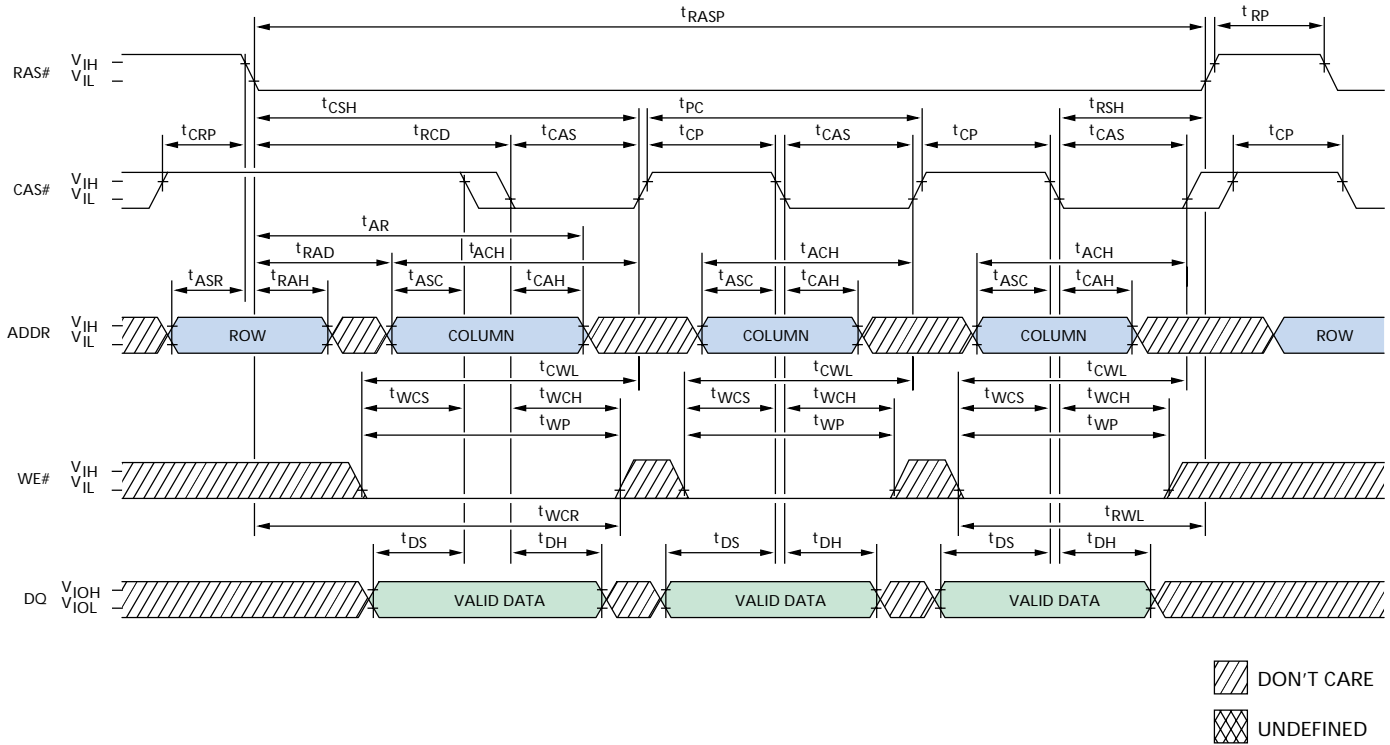

**EDO-PAGE-MODE EARLY WRITE CYCLE**

**TIMING PARAMETERS**

SYMBOL	-5		-6		UNITS
	MIN	MAX	MIN	MAX	
$t_{ACH}$	12		15		ns
$t_{AR}$	38		45		ns
$t_{ASC}$	0		0		ns
$t_{ASR}$	0		0		ns
$t_{CAH}$	8		10		ns
$t_{CAS}$	8	10,000	10	10,000	ns
$t_{CLCH}$	5		5		ns
$t_{CP}$	8		10		ns
$t_{CRP}$	5		5		ns
$t_{CSH}$	38		45		ns
$t_{CWL}$	8		10		ns
$t_{DH}$	8		10		ns
$t_{DS}$	0		0		ns

SYMBOL	-5		-6		UNITS
	MIN	MAX	MIN	MAX	
$t_{PC}$	20		25		ns
$t_{RAD}$	9		12		ns
$t_{RAH}$	7		10		ns
$t_{RASP}$	50	125,000	60	125,000	ns
$t_{RCD}$	11		14		ns
$t_{RP}$	30		40		ns
$t_{RSH}$	13		15		ns
$t_{RWL}$	13		15		ns
$t_{WCH}$	8		10		ns
$t_{WCR}$	38		45		ns
$t_{WCS}$	0		0		ns
$t_{WP}$	5		5		ns

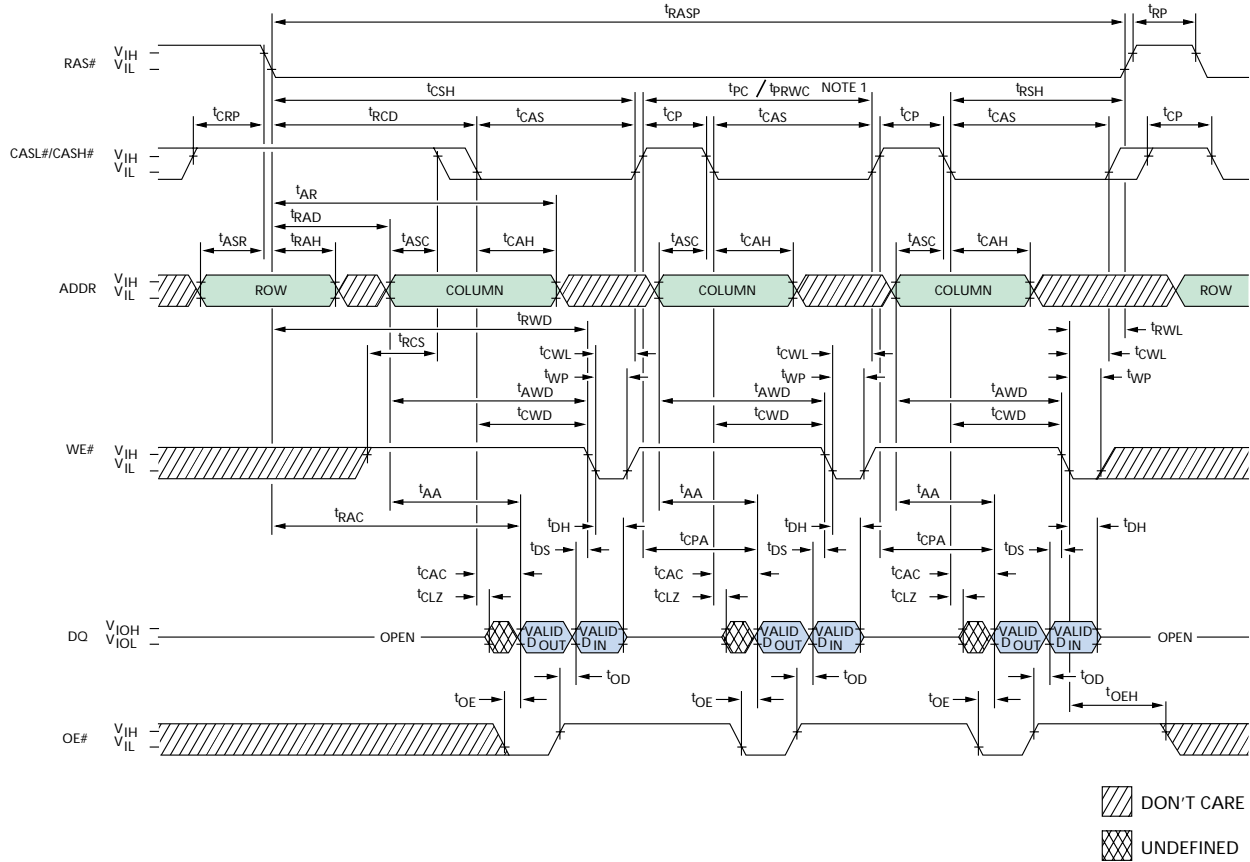
### EDO-PAGE-MODE READ-WRITE CYCLE (LATE WRITE and READ-MODIFY-WRITE cycles)



#### TIMING PARAMETERS

SYMBOL	-5		-6		UNITS
	MIN	MAX	MIN	MAX	
tAA		25		30	ns
tAR	38		45		ns
tASC	0		0		ns
tASR	0		0		ns
tAWD	42		49		ns
tCAC		13		15	ns
tCAH	8		10		ns
tCAS	8	10,000	10	10,000	ns
tCLCH	5		5		ns
tCLZ	0		0		ns
tCP	8		10		ns
tCPA		28		35	ns
tCRP	5		5		ns
tCSH	38		45		ns
tCWD	28		35		ns
tCWL	8		10		ns
tDH	8		10		ns

SYMBOL	-5		-6		UNITS
	MIN	MAX	MIN	MAX	
tDS	0		0		ns
tOD	0	12	0	15	ns
tOE		12		15	ns
tOEh	8		10		ns
tPC	20		25		ns
tPRWC	47		56		ns
tRAC		50		60	ns
tRAD	9		12		ns
tRAH	7		10		ns
tRASP	50	125,000	60	125,000	ns
tRCD	11		14		ns
tRCS	0		0		ns
tRP	30		40		ns
tRSH	13		15		ns
tRWD	67		79		ns
tRWL	13		15		ns
tWP	5		5		ns

**NOTE:** 1. tPC is for LATE WRITE cycles only.

### EDO-PAGE-MODE READ EARLY WRITE CYCLE (Pseudo READ-MODIFY-WRITE)

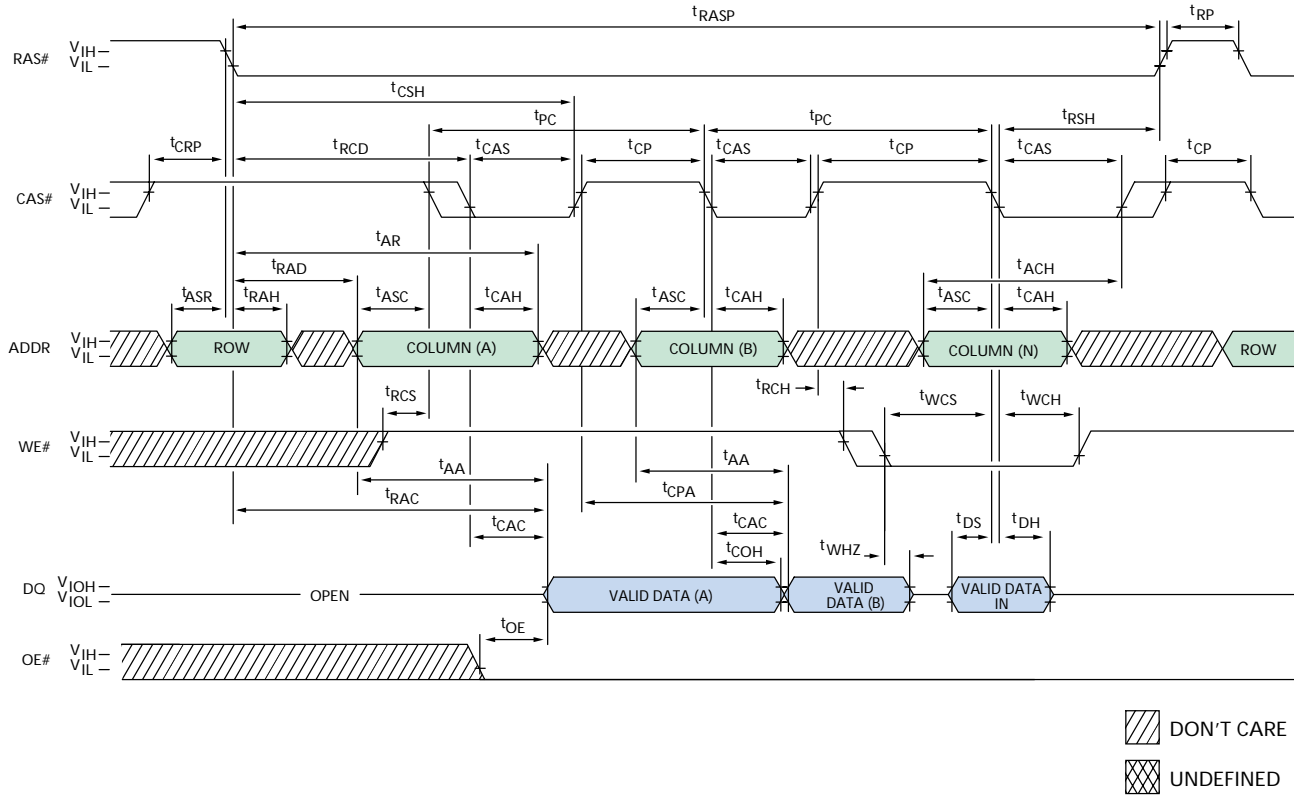

#### TIMING PARAMETERS

SYMBOL	-5		-6		UNITS
	MIN	MAX	MIN	MAX	
t <sub>AA</sub>		25	MIN	30	ns
t <sub>ACH</sub>	12		15		ns
t <sub>AR</sub>	38		45		ns
t <sub>ASC</sub>	0		0		ns
t <sub>ASR</sub>	0		0		ns
t <sub>CAC</sub>		13		15	ns
t <sub>CAH</sub>	8		10		ns
t <sub>CAS</sub>	8	10,000	10	10,000	ns
t <sub>COH</sub>	3		3		ns
t <sub>CP</sub>	8		10		ns
t <sub>CPA</sub>		28		35	ns
t <sub>CRP</sub>	5		5		ns
t <sub>CSH</sub>	38		45		ns
t <sub>DH</sub>	8		10		ns
t <sub>DS</sub>	0		0		ns

SYMBOL	-5		-6		UNITS
	MIN	MAX	MIN	MAX	
t <sub>OE</sub>		12		15	ns
t <sub>PC</sub>	20		25		ns
t <sub>RAC</sub>		50		60	ns
t <sub>RAD</sub>	9		12		ns
t <sub>RAH</sub>	7		10		ns
t <sub>RASP</sub>	50	125,000	60	125,000	ns
t <sub>RCD</sub>	11		14		ns
t <sub>RCH</sub>	0		0		ns
t <sub>RCS</sub>	0		0		ns
t <sub>RP</sub>	30		40		ns
t <sub>RSH</sub>	13		15		ns
t <sub>WCH</sub>	8		10		ns
t <sub>WCS</sub>	0		0		ns
t <sub>WHZ</sub>		12		15	ns

### READ CYCLE (with WE#-controlled disable)

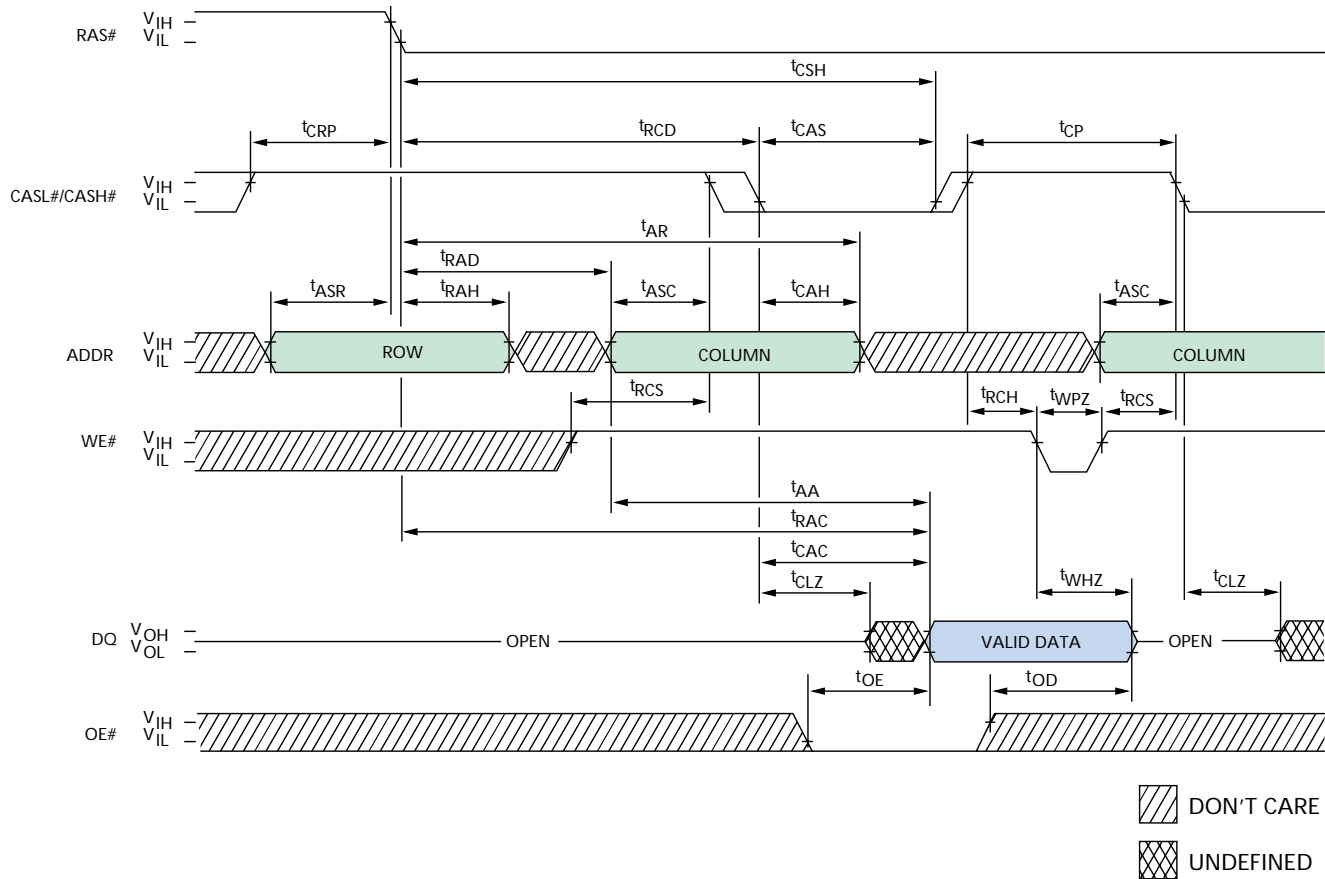

#### TIMING PARAMETERS

SYMBOL	-5		-6		UNITS
	MIN	MAX	MIN	MAX	
$t_{AA}$		25		30	ns
$t_{AR}$	38		45		ns
$t_{ASC}$	0		0		ns
$t_{ASR}$	0		0		ns
$t_{CAC}$		13		15	ns
$t_{CAH}$	8		10		ns
$t_{CAS}$	8	10,000	10	10,000	ns
$t_{CLZ}$	0		0		ns
$t_{CP}$	8		10		ns
$t_{CRP}$	5		5		ns
$t_{CSH}$	38		45		ns

SYMBOL	-5		-6		UNITS
	MIN	MAX	MIN	MAX	
$t_{OD}$	0	12	0	15	ns
$t_{OE}$		12		15	ns
$t_{RAC}$		50		60	ns
$t_{RAD}$	9		12		ns
$t_{RAH}$	7		10		ns
$t_{RCD}$	11		14		ns
$t_{RCH}$	0		0		ns
$t_{RCS}$	0		0		ns
$t_{WHZ}$		12		15	ns
$t_{WPZ}$	10		10		ns

### RAS#-ONLY REFRESH CYCLE (OE# and WE# = DON'T CARE)

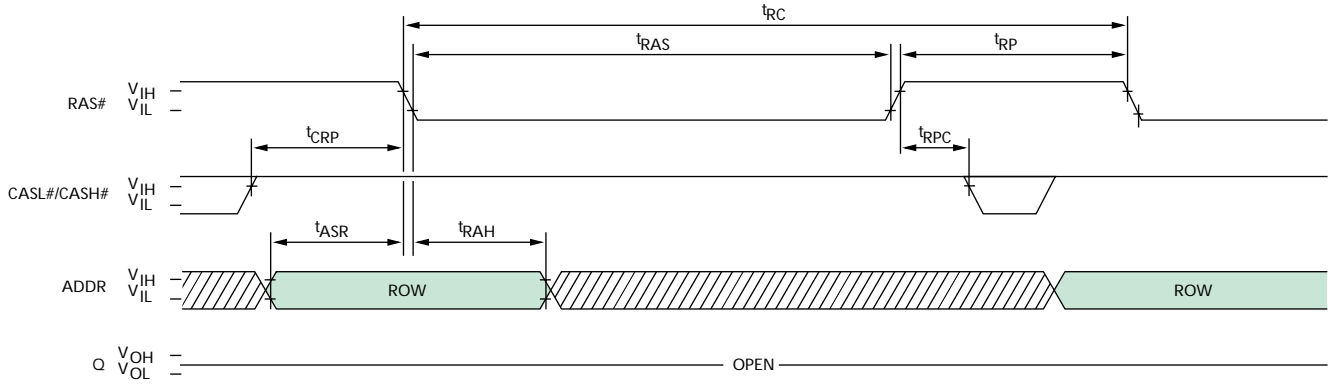

### CBR REFRESH CYCLE (Addresses and OE# = DON'T CARE)

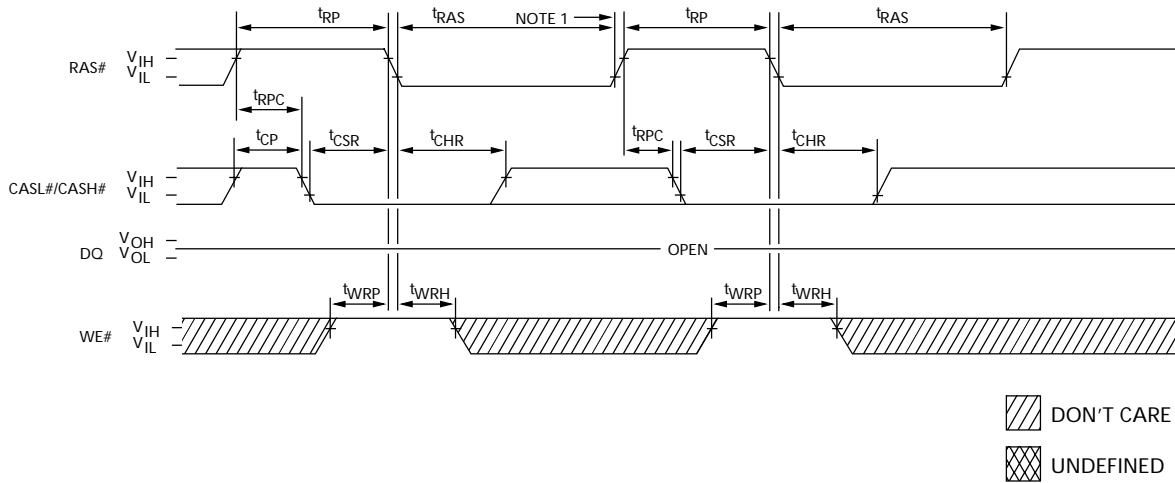

#### TIMING PARAMETERS

SYMBOL	-5		-6		UNITS
	MIN	MAX	MIN	MAX	
$t_{ASR}$	0		0		ns
$t_{CHR}$	8		10		ns
$t_{CP}$	8		10		ns
$t_{CRP}$	5		5		ns
$t_{CSR}$	5		5		ns
$t_{RAH}$	7		10		ns

SYMBOL	-5		-6		UNITS
	MIN	MAX	MIN	MAX	
$t_{RAS}$	50	10,000	60	10,000	ns
$t_{RC}$	84		104		ns
$t_{RP}$	30		40		ns
$t_{RPC}$	5		5		ns
$t_{WRH}$	8		10		ns
$t_{WRP}$	8		10		ns

**NOTE:** 1. End of first CBR REFRESH cycle.

### HIDDEN REFRESH CYCLE <sup>1</sup> (WE# = HIGH; OE# = LOW)

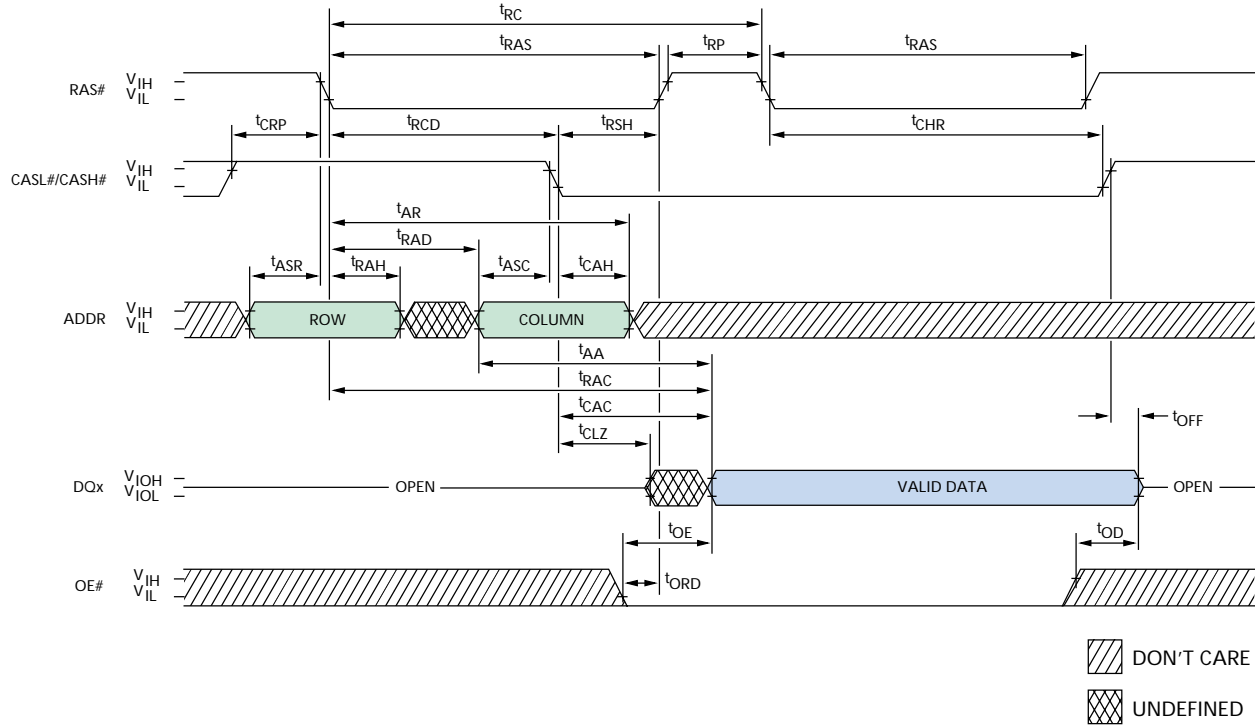

#### TIMING PARAMETERS

SYMBOL	-5		-6		UNITS
	MIN	MAX	MIN	MAX	
t <sub>AA</sub>		25		30	ns
t <sub>AR</sub>	38		45		ns
t <sub>ASC</sub>	0		0		ns
t <sub>ASR</sub>	0		0		ns
t <sub>CAC</sub>		13		15	ns
t <sub>CAH</sub>	8		10		ns
t <sub>CHR</sub>	8		10		ns
t <sub>CLZ</sub>	0		0		ns
t <sub>CRP</sub>	5		5		ns
t <sub>OD</sub>	0	12	0	15	ns

SYMBOL	-5		-6		UNITS
	MIN	MAX	MIN	MAX	
t <sub>OE</sub>		12		15	ns
t <sub>OFF</sub>	0	12	0	15	ns
t <sub>ORD</sub>	0		0		ns
t <sub>RAC</sub>		50		60	ns
t <sub>RAD</sub>	9		12		ns
t <sub>RAH</sub>	7		10		ns
t <sub>RAS</sub>	50	10,000	60	10,000	ns
t <sub>RCD</sub>	11		14		ns
t <sub>RP</sub>	30		40		ns
t <sub>RSH</sub>	13		15		ns

**NOTE:** 1. A HIDDEN REFRESH may also be performed after a WRITE cycle. In this case, WE# is LOW and OE# is HIGH.

### SELF REFRESH CYCLE (Addresses and OE# = DON'T CARE)

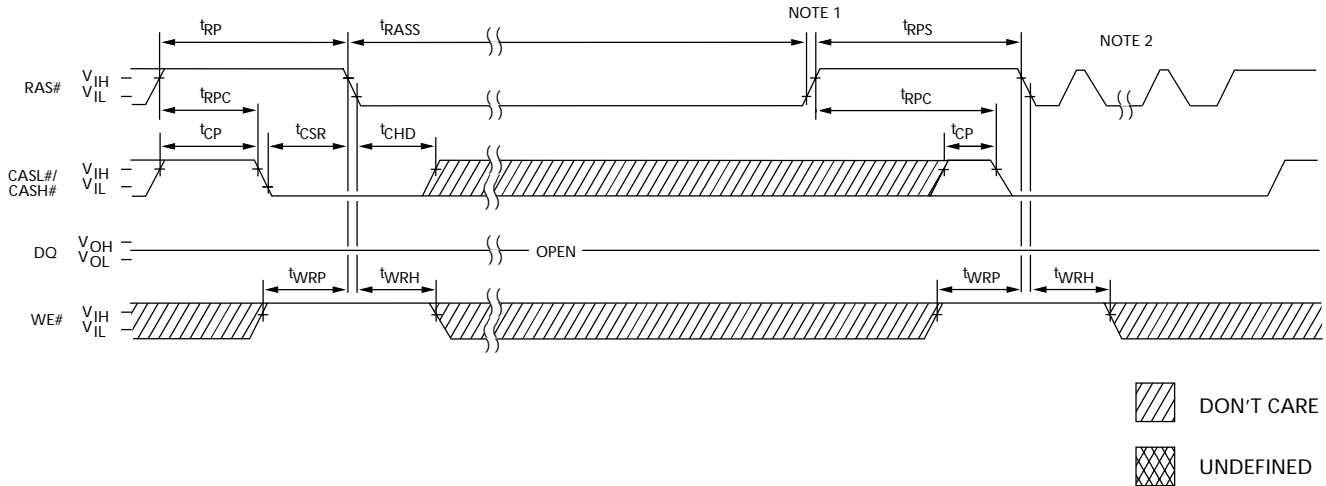

#### TIMING PARAMETERS

SYMBOL	-5		-6		UNITS
	MIN	MAX	MIN	MAX	
$t_{CHD}$	15		15		ns
$t_{CLCH}$	5		5		ns
$t_{CP}$	8		10		ns
$t_{CSR}$	5		5		ns
$t_{RASS}$	100		100		ns

SYMBOL	-5		-6		UNITS
	MIN	MAX	MIN	MAX	
$t_{RP}$	30		40		ns
$t_{RPC}$	5		5		ns
$t_{RPS}$	90		105		ns
$t_{WRH}$	8		10		ns
$t_{WRP}$	8		10		ns

**NOTE:** 1. Once  $t_{RASS}$  (MIN) is met and RAS# remains LOW, the DRAM will enter self refresh mode.  
2. Once  $t_{RPS}$  is satisfied, a complete burst of all rows should be executed if RAS#-only or burst CBR refresh is used.

50-PIN PLASTIC TSOP (400 mil)

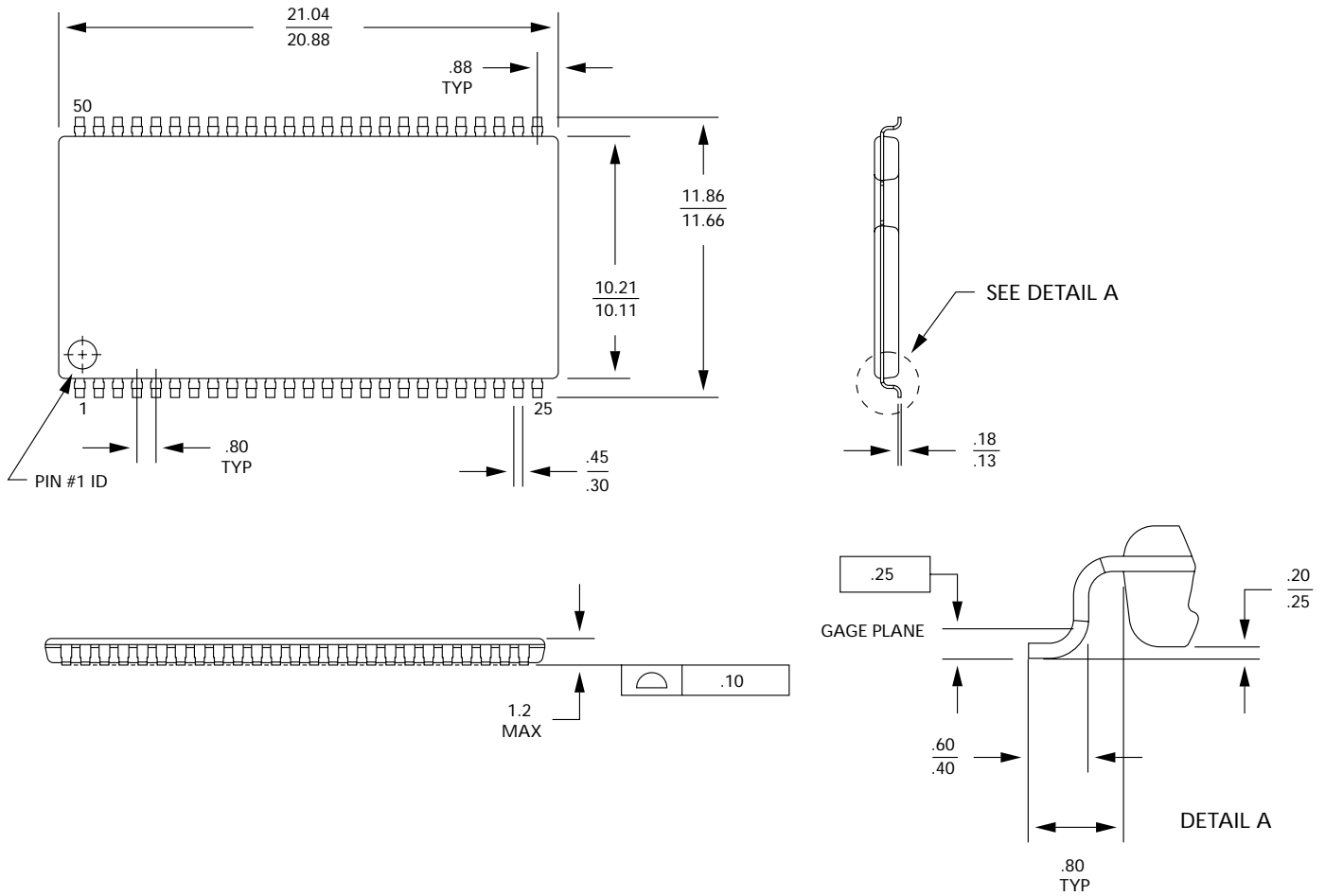

- NOTE:** 1. All dimensions in millimeters MAX or typical where noted.  
MIN
2. Package width and length do not include mold protrusion; allowable mold protrusion is .25mm per side.



8000 S. Federal Way, P.O. Box 6, Boise, ID 83707-0006, Tel: 208-368-3900

E-mail: [prodmtg@micron.com](mailto:prodmtg@micron.com), Internet: <http://www.micron.com>, Customer Comment Line: 800-932-4992

Micron is a registered trademark of Micron Technology, Inc.