

DC/DC power module 3.3V / 4.5A / 14.8W

- SMD package with ultra low component height 8.0 mm (0.315 in.)
- 84% efficiency at full load
- 1,500 Vdc isolation voltage
- Synchronous rectification
- MTTF >10 million hours at +50°C case temperature (+40°C ambient)
- Low EMI



Patents Pending

The MacroDens™ PKF 4110B I true component level on-board DC/DC power modules are intended as distributed power sources in decentralized –48 and –60VDC power systems. The over-moulded rugged design also makes them suitable for other demanding industrial applications. They are optimized for an operational ambient

temperature range in compliance with present and future application needs, including non temperature controlled environments. The mechanical design offers a surface mount version, delivered in ready-to-use tubes, trays or tape & reel package, and compatibility with semi and fully aqueous cleaning processes.

E

Absolute Maximum Ratings

Characteristics		min	max	Unit
T _C	Case temperature at full output power	-45	+100	°C
T _S	Storage temperature	-55	+125	°C
V _I	Continuous input voltage ¹⁾	-0.5	+75	V dc
V _{ISO}	Isolation voltage (input to output test voltage)	1,500		V dc
V _{Tr}	Transient input energy		0.01	Ws
V _{RC}	Remote control voltage pin 11 ref. to pin 17	-5	+16	V dc
V _{adj}	Output adjust voltage pin 8 ref. to pin 17	-5	+40	V dc

Stress in excess of Absolute Maximum Ratings may cause permanent damage. Absolute Maximum Ratings, sometimes referred to as no destruction limits, are normally tested with one parameter at a time exceeding the limits of Output data or Electrical Characteristics. If exposed to stress above these limits, function and performance may degrade in an unspecified manner.

Input T_C < T_{Cmax} unless otherwise specified

Characteristics		Conditions	min	typ	max	Unit
V _I	Input voltage range ¹⁾²⁾		36		75	V
V _{Ioff}	Turn-off input voltage	See typical characteristics	30.0	33.5	35.0	V
V _{Ion}	Turn-on input voltage	See typical characteristics	32.0	34.5	36.0	V
C _I	Input capacitance			1.4		μF
P _{II}	Input idling power	I _O = 0, T _C = -30... +95 °C	(V _I = 53V) (V _I = 66V)	1000 1200		mW
P _{RC}	Input stand-by power	T _C = -30... +95 °C, RC connected to pin 17	(V _I = 53V) (V _I = 66V)	41 66		mW

NOTES:

- 1) The input voltage range 36...75 V dc meets the European Telecom Standard prETS 300 132-2 Nominal input voltage range in 48 V and 60 V dc power systems, -40.5...-57.0 V and -50.0...-72.0 V respectively. Absolute max continuous input voltage is 75 V dc.
- 2) The power modules will operate down to ≤35V, when V_I decreases, but will turn on at V_I ≤36V, when V_I increases (see also Operating information).

Connections

Pin	Designation	Function
1	Out 1	Output 1*
2	Rtn	Output return.
3	Out 1	Output 1, Preferred output *. Positive voltage ref. to Rtn.
4-7	NC	Not connected. Isolated from each other.
8	V _{adj}	Output voltage adjust.
9	NC	Not connected.
10	NC	Not connected.
11	RC	Remote control. Used to turn-on and turn-off output.
12-16	NC	Not connected. Isolated from each other.
17	-In	Negative input.
18	+In	Positive input.

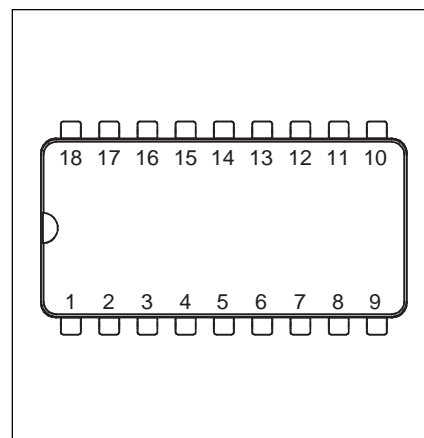

* Output pin 3 is preferred, for optimum performance use both pin 1 & 3.

Safety

The PKF 4110B I DC/DC power module meets the isolation requirements of UL/EN 60 950, *Safety of information technology equipment including electrical business equipment*.

The PKF power modules are recognized by UL and meet the applicable requirements in UL 1950 *Safety of information technology equipment*, the applicable Canadian safety requirements and UL 1012 *Standard for power supplies*.

The DC/DC power module shall be installed in an end-use equipment and considerations should be given to measuring the case temperature to comply with T_{Cmax} when in operation. Abnormal component tests are conducted with the input protected by an external 15 A fuse. The need for repeating these tests in the end-use appliance shall be considered if installed in a circuit having higher rated devices.

When the supply to the DC/DC power module meets all the requirements for SELV (<60Vdc), the output is considered to remain within SELV limits (level 3). The isolation is an operational insulation in accordance with EN 60 950.

The DC/DC power module is intended to be supplied by isolated secondary circuitry and shall be installed in compliance with the requirements of the ultimate application. If they are connected to a 60 V DC system reinforced insulation must be provided in the power supply that isolates the input from the mains. Single fault testing in the power supply must be performed in combination with the DC/DC power module to demonstrate that the output meets the requirement for SELV. One pole of the input and one pole of the output is to be grounded or both are to be kept floating.

The terminal pins are only intended for connection to mating connectors of internal wiring inside the end-use equipment.

These DC/DC power modules may be used in telephone equipment in accordance with paragraph 34 A.1 of UL 1459 (Standard for Telephone Equipment, second edition).

The galvanic isolation is verified in an electric strength test. Test voltage (V_{ISO}) between input and output is 1,500 Vdc for 60 s. In production the test duration may be decreased to 1 s.

The capacitor between input and output has a value of 1nF and the leakage current is less than $1\mu A @ 53 Vdc$.

The case is designed in non-conductive epoxy. Its flammability rating meets UL 94V-0. The oxygen index is 34%.

Electrical Data

Fundamental circuit diagram

Single output

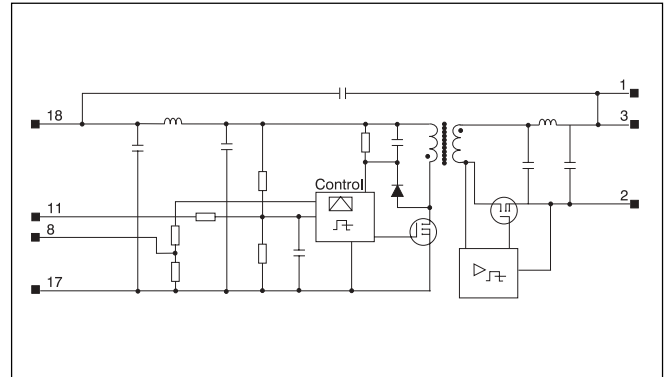

Transient input voltage

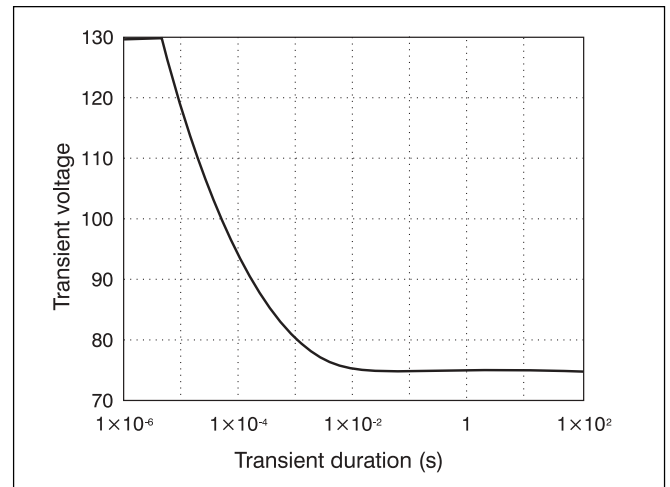

Single voltage pulse at +25°C ambient temperature.

Output

$T_C = -30 \dots +95 \text{ }^\circ\text{C}$, $V_I = 36 \dots 75 \text{ V}$.

Characteristics		Conditions		Output 1			Unit
				min	typ	max	
V_{O_i}	Output voltage initial setting and accuracy	$T_C = +25 \text{ }^\circ\text{C}$, $I_O = 3.5 \text{ A}$, $V_I = 53 \text{ V}$		3.23	3.30	3.36	V
	Output adjust range ¹⁾			2.80		3.80	V
V_O	Output voltage tolerance band	Long term drift included	$I_O = 0.4 \dots 4.5 \text{ A Pin 1+3}$	3.17		3.43	V
			$I_O = 0.4 \dots 4.5 \text{ A Pin 1}$	3.10		3.43	V
	Idling voltage	$I_O = 0 \text{ A}$		3.14	3.30	3.47	V
	Line regulation	$I_O = 4.5 \text{ A}$	$V_I = 38 \dots 60 \text{ V}$	10			mV
			$V_I = 50 \dots 75 \text{ V}$	10			
Load regulation	$I_O = 0 \dots 4.5 \text{ A}$, $V_I = 53 \text{ V}$		50			mV	
t_{tr}	Load transient recovery time	$I_O = 0.3 \dots 4.5 \text{ A}$, $V_I = 53 \text{ V}$ load step = 2 A		50			μs
V_{Tr}	Load transient voltage			+250			mV
				-250			mV
T_{coeff}	Temperature coefficient ²⁾	$I_O = 4.5 \text{ A}$, $T_C = 40 \dots +90 \text{ }^\circ\text{C}$		+0.3			$\text{mV}/^\circ\text{C}$
t_r	Ramp-up time	$I_O = 0.3 \dots 4.5 \text{ A}$, $0.1 \dots 0.9 \times V_O$, $V_I = 53 \text{ V}$		2			ms
t_s	Start-up time	$I_O = 0.3 \dots 4.5 \text{ A}$, $V_I = 53 \text{ V}$ From V_I connection to $V_O = 0.9 \times V_{O_i}$		6			ms
I_O	Output current ³⁾			0		4.5	A
P_{Omax}	Max output power ³⁾	Calculated value		14.85			W
I_{lim}	Current limiting threshold	$T_C < T_{Cmax}$, $V_O = 3.0 \text{ V}$		5.5			A
I_{sc}	Short circuit current	$V_O = 0.2 \dots 0.5 \text{ V}$, $T_C = +25 \text{ }^\circ\text{C}$		6.3			A
V_{Oac}	Output ripple & noise	$I_O = 3 \text{ A}$	20 Hz...5 MHz	20		50	mV_{p-p}
		$I_O = 4.5 \text{ A}$	20 Hz...5 MHz	30		70	mV_{p-p}
		$I_O = 4 \text{ A}$	0.6...50 MHz			80	$\text{dB}\mu\text{V}$
SVR	Supply voltage rejection (ac)	$f = 100 \text{ Hz sine wave}$, $1V_{p-p}$, $V_I = 53 \text{ V}$ ($\text{SVR} = 20 \log(1 V_{p-p}/V_{O(p-p)})$)		60			dB

¹⁾ See also Operating Information

²⁾ See Typical Characteristics

³⁾ Peak current at startup = 5 A

Miscellaneous

Characteristics		Conditions		min	typ	max	Unit	
η	Efficiency	$I_O = 4.5 \text{ A}$	$V_I = 53 \text{ V}$	80	84		%	
			$V_I = 66 \text{ V}$	80	83			
P_d	Power dissipation		$V_I = 53 \text{ V}$				3.7	W
			$V_I = 66 \text{ V}$				3.7	

Typical Characteristics

Efficiency (typ) @ $T_A = +25^\circ\text{C}$

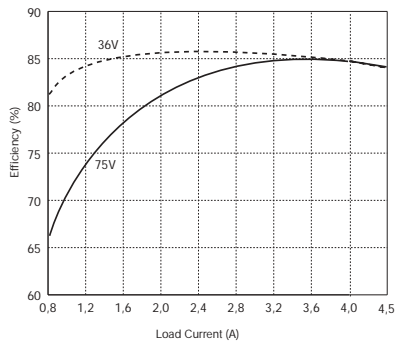

Power derating

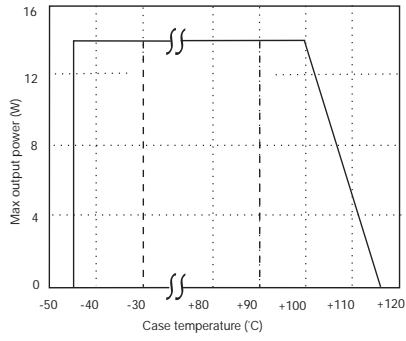

Output characteristic (typ)

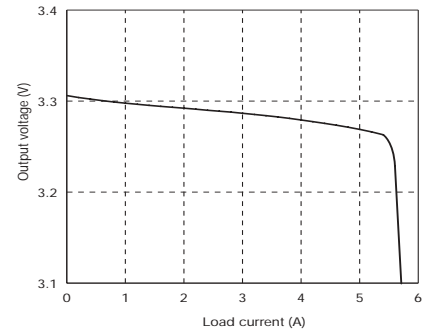

Output Voltage temperature characteristic

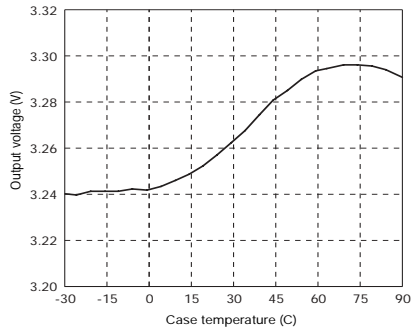

Turn-on/turn-off input voltage

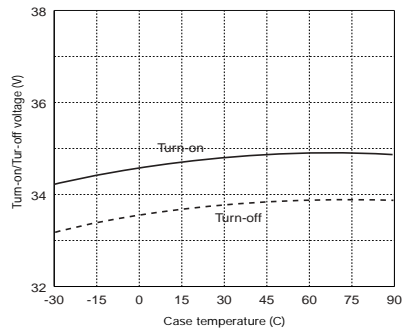

Dynamic load response (typ) @ $+25^\circ\text{C}$

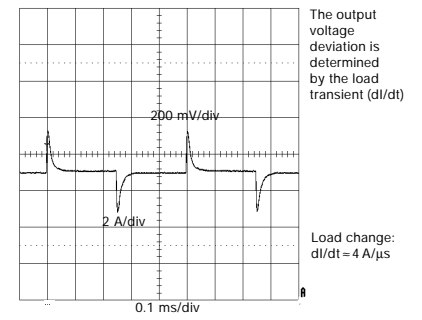

Current derating

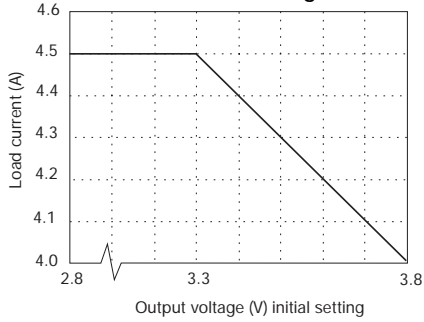

EMC Specifications

The PKF power module is measured directly.
 The fundamental switching frequency is 305 kHz $\pm 5\%$ @
 $I_O = (0.1 \dots 1.0) \times I_{Omax}$.

Conducted EMI (input terminals)

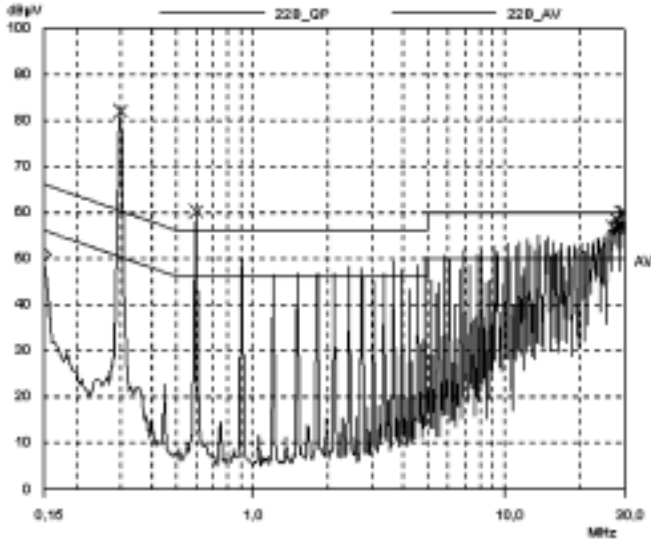

External Filter (class B)

Required external input filter in order to meet class B in EN 55022, CISPR 22 and FCC part 15J.

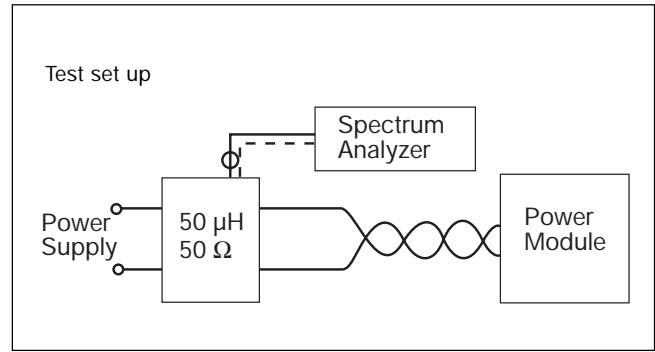
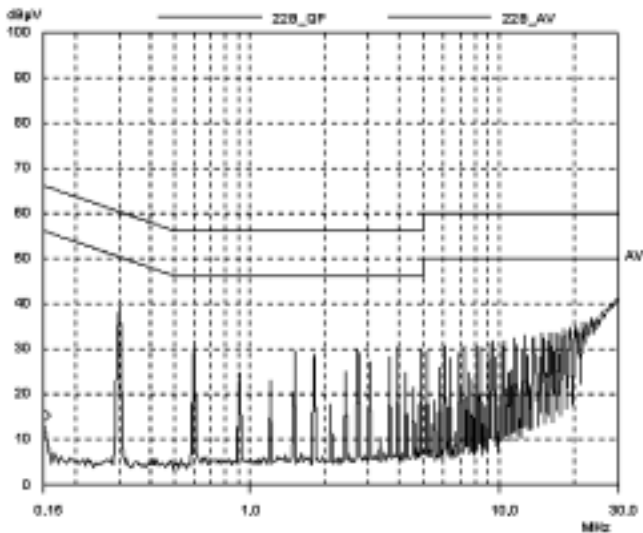
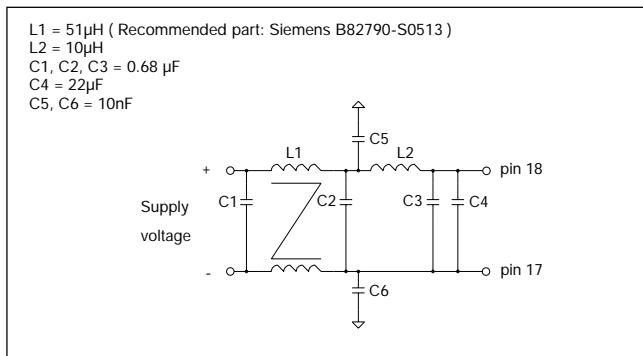

Radiated EMS (Electro-Magnetic Fields)

Radiated EMS is measured according to test methods in IEC Standard publ. 801-3. No deviation outside the V_O tolerance band will occur under the following conditions:

Frequency range	Voltage level
0.01...200 MHz	3 V_{rms}/m
200...1,000 MHz	3 V_{rms}/m
1...12 GHz	10 V_{rms}/m

Conducted EMS

Electro Magnetic Susceptibility is measured by injection of electrical disturbances on the input terminals. No deviation outside the V_O tolerance band will occur under the following conditions:

Frequency range	Voltage level
30...300 MHz	1.0 V_{rms}

The signal is amplitude modulated with 1 kHz/80% and applied in both differential and common mode.

ESD

Electro Static Discharge is tested according to IEC publ. 801-2. No destruction will occur if the following voltage levels are applied to any of the terminal pins:

Test	Voltage level
Air discharge	± 4 kV
Contact discharge	± 2 kV

EFT

Electrical Fast Transients on the input terminals could affect the output voltage regulation causing functional errors on the Printed Board Assembly (PBA). The PKF power modules withstand EFT levels of 0.5 kV keeping V_O within the tolerance band and 2.0 kV without destruction. Tested according to IEC publ. 801-4.

Output Ripple & Noise (V_{Oac})

Output ripple is measured as the peak to peak voltage of the fundamental switching frequency.

Operating Information

Remote Control (RC)

Turn-on or turn-off can be realized by using the RC-pin. If pin 11 is connected to pin 17 the power module turns off. Normal operation is achieved if pin 11 is open (NC). To ensure safe turn-off the voltage difference between pin 11 and 17 shall be less than 1.0V. RC is an TTL open collector compatible output with a sink capacity >300 μA (see fig. 1).

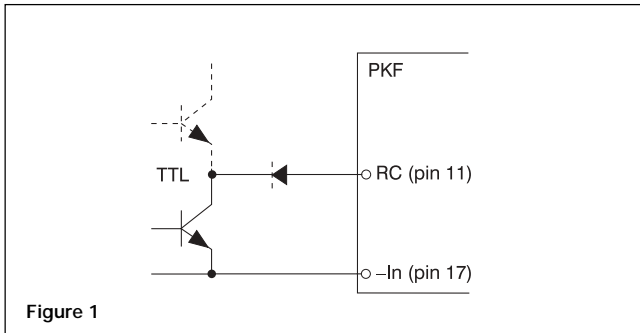

Turn-on/off Input Voltage

The power module monitors the input voltage and will turn on and turn off at predetermined levels. This is not adjustable.

Output Voltage Adjust (V_{adj})

Output voltage, V_O , can be adjusted by using an external resistor or other external circuitry. If other circuitry is used, the slew rate has to be limited to maximum 5 V/ms.

To increase V_O a resistor should be connected between pin 8 and 17. To calculate the appropriate resistor use the following formula:

$$R_{adj_{nom}} = 4,14 \times \frac{(1,28 \times V_{O_i} - V_{O_d})}{(V_{O_d} - V_{O_i})} \quad (\text{k}\Omega)$$

V_{O_i} is the output voltage initial setting.

V_{O_d} is the desired output voltage.

To decrease V_O it is necessary to connect a current source to pin 8. (see fig. 2).

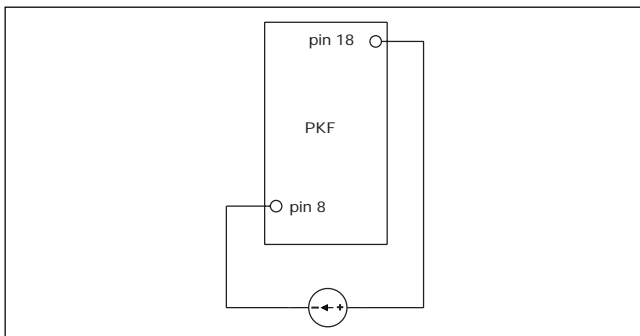

Use the following formula to calculate the necessary current.

$$I_{adj} = 943 \times \left(1 - \frac{V_{O_d}}{V_{O_i}}\right) \quad (\mu\text{A})$$

Parallel Operation

Contact Ericsson for more information.

Information given in this data sheet is believed to be accurate and reliable. No responsibility is assumed for the consequences of its use nor for any infringement of patents or other rights of third parties which may result from its use. No license is granted by implication or otherwise under any patent or patent rights of Ericsson Power Modules. These products are sold only according to Ericsson Power Modules general conditions of sale, unless otherwise confirmed in writing. Specifications subject to change without notice.

Ericsson Power Modules

SE-141 75 Kungens Kurva, Sweden

Telephone: +46 8 568 69620

For local sales contacts, please refer to our website

www.ericsson.com/powermodules

or call: Int +46 8 568 69620, Fax: +46 8 568 69599

Americas

Ericsson Inc., Power Modules

+1-877-374-2642

Asia/Pacific

Ericsson Ltd.

+852-2590-7152

The latest and most complete information can be found on our website!

Data Sheet

EN/LZT 146 62 R2A

© Ericsson Power Modules AB, February 2003