

T-46-23-12

Ordering number: EN3752

CMOS LSI

**SANYO** **LC3517B, BM, BS, BL, BML, BSL**  
2048-word × 8-bit CMOS Static RAM

**OVERVIEW**

LC3517B series devices are silicon-gate CMOS, static RAM ICs configured as 2048 words × 8 bits. They incorporate an output enable for high-speed memory access, and TTL-compatible, tristate outputs for direct interfacing with a bus.

LC3517B series ICs feature a data retention mode and a low standby current, making them ideal for low-power or battery-powered equipment. In particular, the LC3517BL, LC3517BML and LC3517BSL offer a guaranteed maximum standby current of 1 μA at 60 deg. C.

LC3517B series ICs operate from a 5 V supply and are available in 24-pin DIPs, 24-pin MFPs and 24-pin SDIPs.

**FEATURES**

- 120 ns (LC3517B-12 series) and 150 ns (LC3517B-15 series) maximum address access times
- 0.2 μA at 25 deg. C and 1.0 μA at 60 deg. C (LC3517BL/BML/BSL-12/15), and 5.0 μA at 60 deg. C and 30 μA at 85 deg. C (LC3517B/BM/BS-12/15) maximum standby currents
- 9 mA maximum supply current at f = 1 MHz
- Data retention for V<sub>cc</sub> = 2.0 to 5.5 V
- Asynchronous operation
- TTL-compatible, tristate input/outputs
- Single 5 V supply
- 24-pin DIP, 24-pin MFP and 24-pin SDIP

**PINOUT**

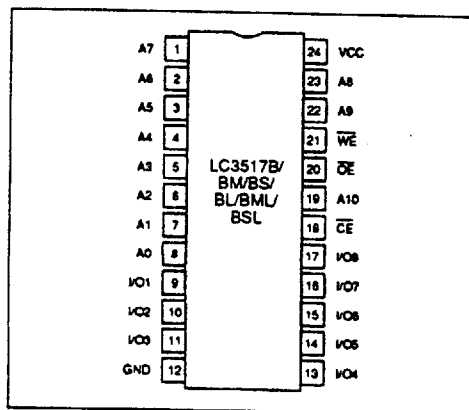

**PACKAGE DIMENSIONS**

Unit: mm

**3072-DIP24NS (LC3517B/BL)**

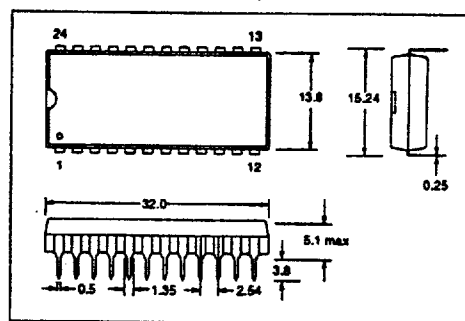

**3045B-MFP24 (LC3517BM/BML)**

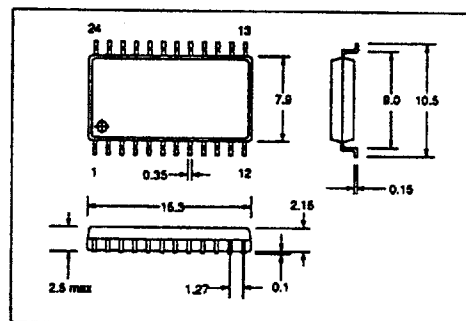

**3114-DIP24NS 300 mil (LC3517BS/BSL)**

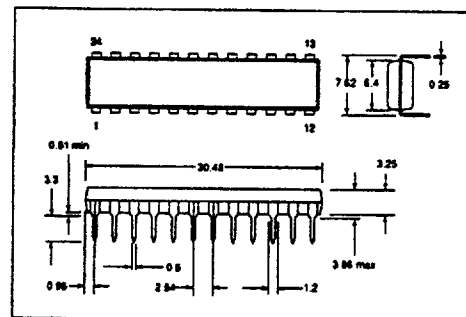

**SANYO Electric Co., Ltd. Semiconductor Division**  
Natsume Bldg., 18-6, 2-chome, Yushima, Bunkyo-ku, Tokyo 113, Japan

No. 3752—1/6

LC3517B, BM, BS, BL, BML, BSL

BLOCK DIAGRAM

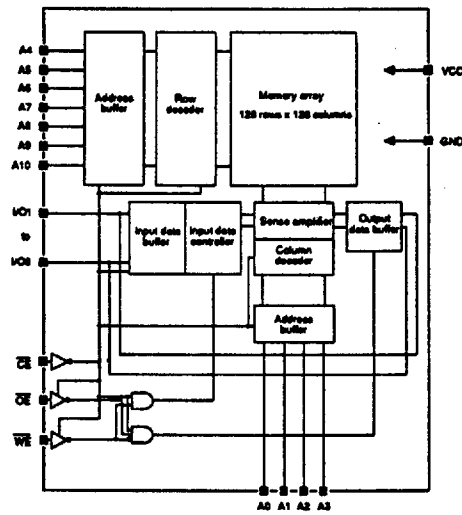

PIN DESCRIPTION

Number	Name	Description
1 to 8, 19, 22, 23	A0 to A10	Address inputs
9 to 11, 13 to 17	I/O1 to I/O8	Data inputs/outputs
12	GND	Ground
18	$\overline{CE}$	Chip enable input
20	$\overline{OE}$	Output enable input
21	$\overline{WE}$	Read/write select input
24	VCC	5 V supply

SPECIFICATIONS

Absolute Maximum Ratings

Parameter	Symbol	Rating	Unit
Supply voltage	V <sub>CC</sub> max	7.0	V
Input voltage range	V <sub>IN</sub>	-0.5 to V <sub>CC</sub> + 0.5	V
Input/output voltage range	V <sub>IO</sub>	-0.5 to V <sub>CC</sub> + 0.5	V
Operating temperature range	T <sub>OPG</sub>	-30 to 85	deg. C
Storage temperature range	T <sub>STG</sub>	-55 to 125	deg. C

T-46-23-12

## LC3517B, BM, BS, BL, BML, BSL

## Recommended Operating Conditions

 $T_a = 25 \text{ deg. C}$ 

Parameter	Symbol	Rating	Unit
Supply voltage	$V_{CC}$	5.0	V
Supply voltage range	$V_{CC \text{ op}}$	4.5 to 5.5	V

## Electrical Characteristics

 $V_{CC} = 5 \text{ V} \pm 10\%$ ,  $T_a = -30 \text{ to } 85 \text{ deg. C}$  unless otherwise noted

Parameter	Symbol	Condition	Rating			Unit	
			min	typ	max		
Quiescent supply current	$I_{CC1}$	$V_{EE} = 0 \text{ V}$ , $V_{IH} = V_{CC}$ or GND, $I_{VO} = 0 \text{ mA}$	-	2	5	mA	
		$V_{EE} = V_{IL}$ , $V_{IH} = V_{IH}$ or $V_{IL}$ , $I_{VO} = 0 \text{ mA}$	-	5	15		
Average supply current	$I_{CC2}$	Minimum cycle time, duty = 100%, $I_{VO} = 0 \text{ mA}$	-	-	50	mA	
		Cycle time = 1 $\mu\text{s}$ , $V_{EE} = 0 \text{ V}$ , $V_{IH} = V_{CC}$ or GND, $I_{VO} = 0 \text{ mA}$	-	4	9		
Standby supply current	$I_{CC3}$	$V_{EE} = V_{CC} - 0.2 \text{ V}$ , $V_{IH} = 0 \text{ V}$ to $V_{CC}$ . See note 1.	$T_a = 60 \text{ deg. C}$	-	-	5.0	$\mu\text{A}$
			$T_a = 85 \text{ deg. C}$	-	-	30	
		$V_{EE} = V_{CC} - 0.2 \text{ V}$ , $V_{IH} = 0 \text{ V}$ to $V_{CC}$ . See note 2.	$T_a = 25 \text{ deg. C}$	-	-	0.2	
			$T_a = 60 \text{ deg. C}$	-	-	1.0	
		$V_{EE} = V_{IH}$ , $V_{IH} = 0 \text{ V}$ to $V_{CC}$	-	1.0	3.0	mA	
LOW-level input voltage	$V_{IL}$		-0.3	-	0.8	V	
HIGH-level input voltage	$V_{IH}$		2.2	-	$V_{CC} + 0.3$	V	
LOW-level output voltage	$V_{OL}$	$I_{OL} = 2.0 \text{ mA}$	-	-	0.4	V	
HIGH-level output voltage	$V_{OH}$	$I_{OH} = -1.0 \text{ mA}$	2.4	-	-	V	
Input capacitance	$C_{IN}$	$V_{IH} = 0 \text{ V}$ , $f = 1 \text{ MHz}$ , $T_a = 25 \text{ deg. C}$	-	-	5	pF	
Input/output capacitance	$C_{VO}$	$V_{VO} = 0 \text{ V}$ , $f = 1 \text{ MHz}$ , $T_a = 25 \text{ deg. C}$	-	-	10	pF	
Input leakage current	$I_{LI}$	$V_{IH} = 0$ to $V_{CC}$	-1.0	-	1.0	$\mu\text{A}$	
Input/output leakage current	$I_{LO}$	$V_{EE}$ or $V_{EE} = V_{IH}$ , $V_{VO} = 0 \text{ V}$ to $V_{CC}$	-5.0	-	5.0	$\mu\text{A}$	

## Notes

- LC3517B/BM/BS-12/15
- LC3517BL/BML/BSL-12/15
- Typical values are measured at  $V_{CC} = 5.0 \text{ V}$  and  $T_a = 25 \text{ deg. C}$ .

## Timing Characteristics

## Test conditions

- LOW-level pulse—0.6 V
- HIGH-level pulse—2.4 V
- Input rise and fall times—5 ns
- LOW-level timing reference— $V_{IL} = V_{OL} = 0.8 \text{ V}$

T-46-23-12

LC3517B, BM, BS, BL, BML, BSL

- HIGH-level timing reference— $V_{DH} = V_{OH} = 2.2\text{ V}$
- Output load—1 TTL gate +  $C_L = 100\text{ pF}$  (including jig capacitance)

Read timing

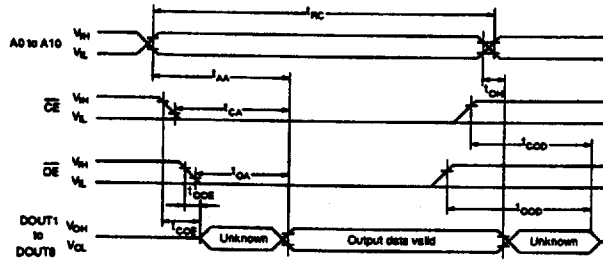

$V_{CC} = 5\text{ V} \pm 10\%$ ,  $T_A = -30\text{ to }85\text{ deg. C}$

Parameter	Symbol	LC3517B/BM/BS-12, LC3517BL/BML/BSL-12		LC3517B/BM/BS-15, LC3517BL/BML/BSL-15		Unit
		min	max	min	max	
Read cycle time	$t_{nc}$	120	-	150	-	ns
Address access time	$t_{AA}$	-	120	-	150	ns
Output-enable access time	$t_{OA}$	-	70	-	80	ns
Chip-enable access time	$t_{CA}$	-	120	-	150	ns
Output hold time	$t_{OH}$	20	-	20	-	ns
Output-enable propagation delay	$t_{OE}$	5	-	5	-	ns
Chip-enable propagation delay	$t_{CE}$	10	-	10	-	ns
Output-disable propagation delay	$t_{OD}$	-	40	-	50	ns
Chip-disable propagation delay	$t_{COO}$	-	40	-	50	ns

Write timing

Write cycle 1

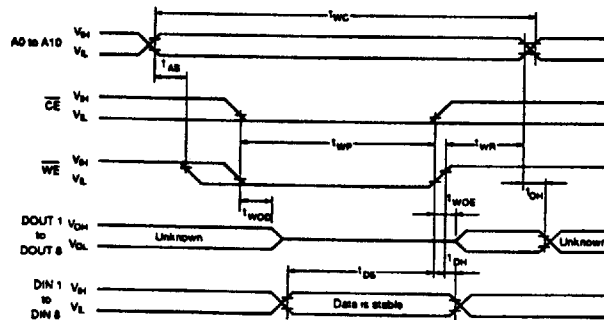

T-46-23-12

LC3517B, BM, BS, BL, BML, BSL

Write cycle 2

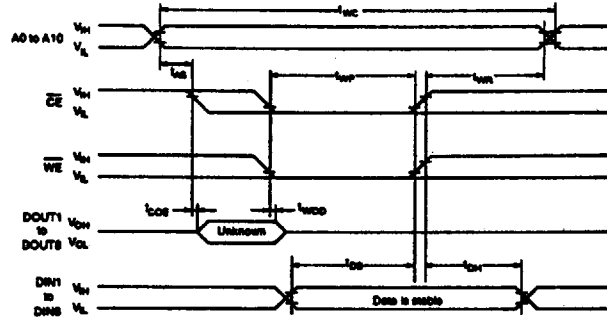

V<sub>CC</sub> = 5 V ±10%, T<sub>a</sub> = -30 to 85 deg. C

Parameter	Symbol	LC3517B/BM/BS-12, LC3517BL/BML/BSL-12		LC3517B/BM/BS-15, LC3517BL/BML/BSL-15		Unit
		min	max	min	max	
Write cycle time	t <sub>WC</sub>	120	-	150	-	ns
Address setup time	t <sub>AS</sub>	0	-	0	-	ns
Write pulsewidth	t <sub>WP</sub>	100	-	120	-	ns
Write recovery time	t <sub>WR</sub>	0	-	0	-	ns
Data setup time	t <sub>DS</sub>	60	-	70	-	ns
Data hold time	t <sub>DH</sub>	0	-	0	-	ns
Write-enable propagation delay	t <sub>WE</sub>	5	-	5	-	ns
Write-disable propagation delay	t <sub>WD</sub>	-	40	-	50	ns

Notes

1. Hold **WE** HIGH during the read cycle.
2. Do not apply opposite phase signals to **DOUT** when it is connected to the output bus.
3. t<sub>WP</sub> is measured when **CE** and **WE** are LOW.
4. t<sub>WR</sub>, t<sub>DS</sub> and t<sub>DH</sub> are measured when **CE** or **WE** is HIGH.
5. **DOUT** becomes high impedance when either **CE** or **OE** is HIGH, or **WE** is LOW.
6. t<sub>AS</sub> is measured when **CE** and **WE** are LOW.
7. **DOUT** is high impedance when **OE** is HIGH during the write cycle.
8. **DOUT** has the same phase as the data to be written during the write cycle.
9. **DOUT** is the data read out from the next address.

Data Retention Characteristics

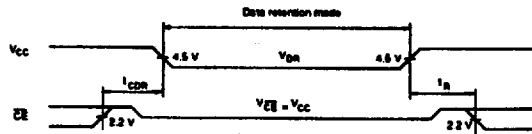

LC3517B, BM, BS, BL, BML, BSL

T<sub>a</sub> = -30 to 85 deg. C

Parameter	Symbol	Condition	Rating			Unit	
			min	typ	max		
Data retention mode supply voltage	V <sub>DR</sub>	V <sub>CE</sub> = V <sub>CC</sub> , V <sub>IN</sub> = 0 V to V <sub>CC</sub>	2.0	-	5.5	V	
Data retention mode supply current	I <sub>CCDR</sub>	V <sub>CE</sub> = V <sub>CC</sub> , V <sub>CC</sub> = 3.0 V, V <sub>IN</sub> = 0 V to V <sub>CC</sub> . See note 1.	T <sub>a</sub> = 60 deg. C	-	-	4.0	μA
			T <sub>a</sub> = 85 deg. C	-	-	20	
		V <sub>CE</sub> = V <sub>CC</sub> , V <sub>CC</sub> = 3.0 V, V <sub>IN</sub> = 0 V to V <sub>CC</sub> . See note 2.	T <sub>a</sub> = 25 deg. C	-	-	0.2	
			T <sub>a</sub> = 60 deg. C	-	-	1.0	
Chip-enable setup time	t <sub>CON</sub>		0	-	-	ns	
Chip-enable hold time	t <sub>H</sub>		t <sub>CH</sub>	-	-	ns	

Notes

1. LC3517B/BM/BS-12/15
2. LC3517BL/BML/BSL-12/15

Mode Selection

Mode	$\overline{CE}$	$\overline{DE}$	$\overline{WE}$	I/O1 to I/O8	Supply current
Read	L	L	H	Data input	I <sub>CCA</sub>
Write	L	X	L	Data output	I <sub>CCA</sub>
Output disable	L	H	X	High impedance	I <sub>CCA</sub>
Standby	H	X	X	High impedance	I <sub>CCS</sub>

Note

X = don't care

Information (including circuit diagrams and circuit parameters) herein is for example only; it is not guaranteed for volume production. SANYO believes information herein is accurate and reliable, but no guarantees are made or implied regarding its use or any infringements of intellectual property rights or other rights of third parties.