

All Band TV Tuner IC (VHF-CATV-UHF)

Description

The CXA1355L is a single chip tuner IC which performs as an oscillator mixer for VHF/CATV bands and UHF bands. An IF amplifier is also provided.

Use of this IC achieves a large reduction of external parts in addition to miniaturizing the tuner and increasing manufacturing productivity, reliability, and ease of design.

Features

- On-chip UHF band OSC and MIX
- Low noise figure
- Reduced spurious interference
- Superior cross modulation distortion
- Ultra small package ensures tuner miniaturization

Applications

- CTV tuner
- CATV UP-DOWN converter
- FM detector for 2IF satellite broadcasts

Structure

Bipolar silicon monolithic IC

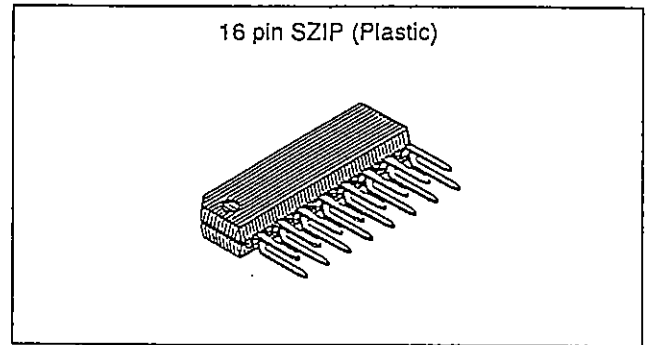

Absolute Maximum Ratings (Ta=25°C)

- Supply voltage Vcc 12 V
- Storage temperature Tstg -55 to +150 °C
- Allowable power dissipation Pd 800 mW

Recommended Operating Conditions

- Supply voltage Vcc 8.1 to 9.9 V
- Operating temperature Topr -20 to +75 °C

Block Diagram and Pin Configuration

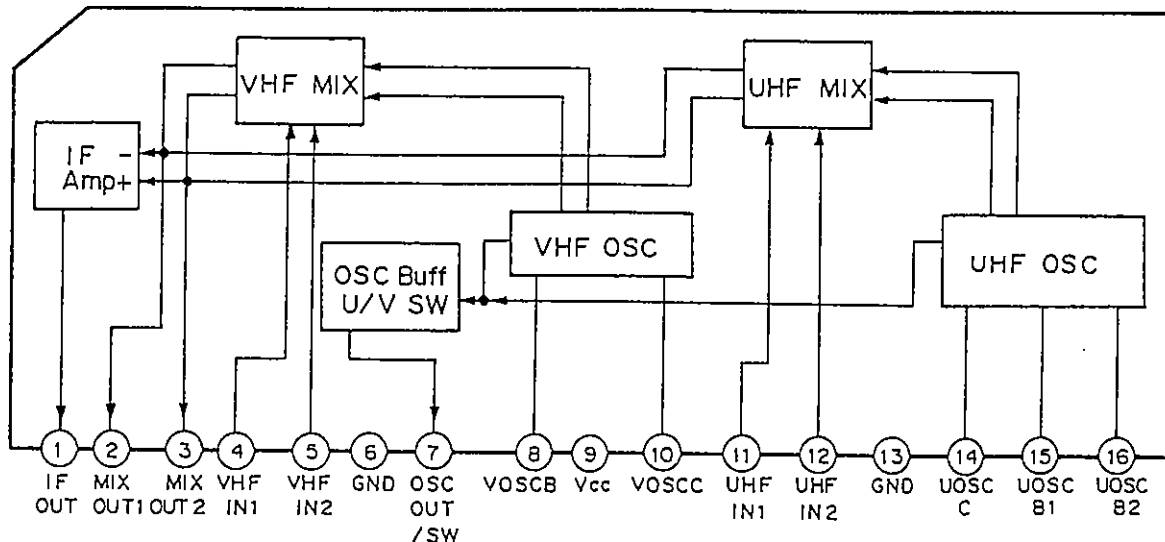

Sony reserves the right to change products and specifications without prior notice. This information does not convey any license by any implication or otherwise under any patents or other right. Application circuits shown, if any, are typical examples illustrating the operation of the devices. Sony cannot assume responsibility for any problems arising out of the use of these circuits.

Pin Description

Pin No.	Symbol	Typical voltage (V)	Equivalent circuit	Description
1	IF OUT	Under VHF operation: 5.4 Under UHF operation: 5.4		IF output.
2	MIX OUT1	7.8 7.7		Doubles as mixer output and IF Amp input.
3	MIX OUT2	7.8 7.7		
4	VHF IN1	2.8 3.2		VHF input; normally a condenser is connected at Pin 4 to GND and Pin 5 is used for input.
5	VHF IN2	2.8 3.2		
6	GND	0		GND
7	OSC OUT/ SW	3V or more 0		Doubles as output pin for OSC monitor and U/V switch pin. Connect 9V source through about a 5kΩ resistor for VHF reception; leave OPEN (0V) for UHF.

Pin No.	Symbol	Typical voltage (V)	Equivalent circuit	Description
8	V OSCB	2.8 3.4		<p>VHF oscillator. Since Pin 10 is an open collector connect power supply through a choke coil or a resistor of about 500Ω .</p>
10	V OSCC	9.0 9.0		
9	Vcc	9.0		Supply pin (9V).
11	UHF IN1	3.2 2.8		<p>UHF input. The differential signal input to Pin 11 and 12.</p>
12	UHF IN2	3.2 2.8		
13	GND	0		GND
14	U OSCC	9.0 9.0		<p>UHF oscillator. Since Pin 14 is an open collector connect power supply through a choke coil or a resistor of about 500Ω .</p>
15	U OSCB1	3.4 2.8		
16	U OSCB2	3.4 2.8		

Electrical Characteristics

See Electrical Characteristics Test Circuit (Ta=25°C, Vcc=9V)

Item	Symbol	Test condition	Min.	Typ.	Max.	Unit
Supply current	IccV	VHF operation; No signal	35.0	45.0	56.0	mA
	IccU	UHF operation; No signal	36.0	46.0	57.0	mA
Conversion gain * 1	CG1	VHF operation; f _{RF} =55MHz	23.0	26.0	29.0	dB
	CG2	VHF operation; f _{RF} =470MHz	23.0	26.0	29.0	dB
	CG3	UHF operation; f _{RF} =470MHz	30.0	33.0	36.0	dB
	CG4	UHF operation; f _{RF} =890MHz	26.0	29.0	32.0	dB
Noise figure * 1	NF1	VHF operation; f _{RF} =55MHz		12.0	14.0	dB
	NF2	VHF operation; f _{RF} =470MHz		13.5	15.5	dB
	NF3	UHF operation; f _{RF} =470MHz		8.5	10.5	dB
	NF4	UHF operation; f _{RF} =890MHz		10.5	13.0	dB
1% Cross modulation * 1 * 2	CM1	VHF operation; f _D =55MHz f _{UD} = ± 12MHz	92.0	95.0		dB μ
	CM2	VHF operation; f _D =470MHz f _{UD} = ± 12MHz	88.0	91.0		dB μ
	CM3	UHF operation; f _D =470MHz f _{UD} = ± 12MHz	85.0	88.0		dB μ
	CM4	UHF operation; f _D =890MHz f _{UD} = ± 12MHz	85.0	88.0		dB μ
Max. output power	P _{omax} (sat)	50Ω load	+8.0	+12.0		dBm
OSC output	P _{oscV}	VHF operation; f _{osc} =515MHz 50Ω load	-19	-16		dBm
	P _{oscU}	UHF operation; f _{osc} =935MHz 50Ω load	-25	-22		dBm

* 1) Measured value for untuned inputs.

Matching NF (noise figure) results in approximately the below values.

NF2 (f_{RF}=470MHz) : 12dB typ. NF4 (f_{RF}=890MHz) : 10dB typ.

For VHF the input is unbalanced and for UHF input is balanced.

* 2) Optimal reception frequency (f_D) input level is -33dBm.Interrupt frequency (f_{UD}) is 100kHz at 40% AM; interrupt frequency level when measured with spectrum analyzer at S/I=46dB.

Application Circuit (UV 3 Band Tuner)

Band SW	Band	BL	BH
VL (80 to 200MHz)	9V	0V/OPEN	
VH (180 to 500MHz)	OPEN	9V	
U (460 to 850MHz)	0V/OPEN	0V/OPEN	

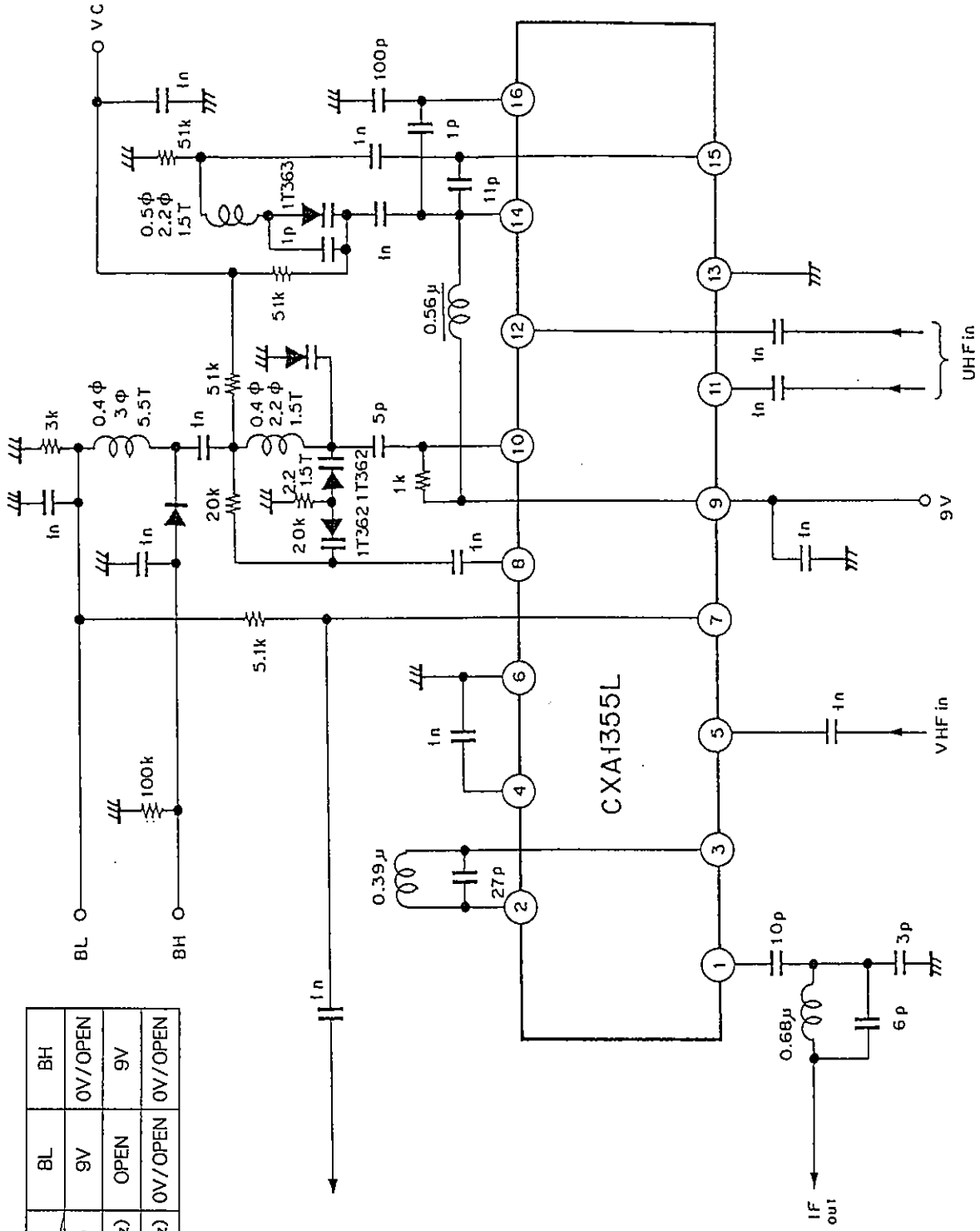

Description of Operation (See Electrical Characteristics Test Circuit Application Circuit)

(1) VHF Oscillator Circuit

Differential amplifier type oscillator circuit with output at Pin 10 and input at Pin 8.

Provide oscillation through applying positive feedback by inputting Pin 10 output through a combination capacitor followed by an LC resonator circuit and a feedback capacitor to Pin 8.

Since Pin 10 is an open collector, connect the power supply through a choke coil or a resistor rated between 510 and 1k Ω .

(2) VHF Mixer Circuit

The mixer circuit employs a double balance mixer for reduce local oscillator signal leakage. The RF is input to Pins 4 and 5. For normal use one pin is grounded and the other pin is the RF input. The RF signal is converted to IF signal with the oscillator signal. The input to the IF amplifier is output to Pins 2 and 3 simultaneously.

(3) UHF Oscillator Circuit

UHF oscillator is formed from a differential amplifier just like the VHF oscillator.

Oscillation should be provided at the point between the transistor base and collector at the differential input as shown in the Application Circuit.

Since Pin 14 is an open collector, connect the power supply through a choke coil or a resistor rated between 510 and 1k Ω .

(4) UHF Mixer Circuit

Double balance mixer is same as VHF mixer. The RF signal is input to Pins 11 and 12. The recommended input method is a balanced differential input from pre-stage double tune circuit.

Otherwise, the conditions and usage are the same as for the VHF Mixer Circuit.

(5) IF Amplifier Circuit

The mixer output signal is amplified by the IF amplifier and output to Pin 1. The output impedance is nearly equal 50 Ω .

(6) U/V Switch Circuit

U/V mode is selected by the DC voltage at Pin 7. UHF operation is chosen by OPEN (0V) input and VHF operation by an input of 3V or more. Pin 7 also functions as an oscillator monitor output. Normally the U/V switch is implemented through the combination of a 5.1k Ω resistor switching from open /9V and a capacitor for filtering out the oscillator signal.

Notes on Usage

Care should be taken in placing external parts because high frequencies are present. Adjust accordingly to prevent heat problems with special care for Pins 6 and 13 (GND) whose heat dissipations accumulate.

Example of Representative Characteristics

Circuit Current vs. Supply Voltage
(VHF operation)

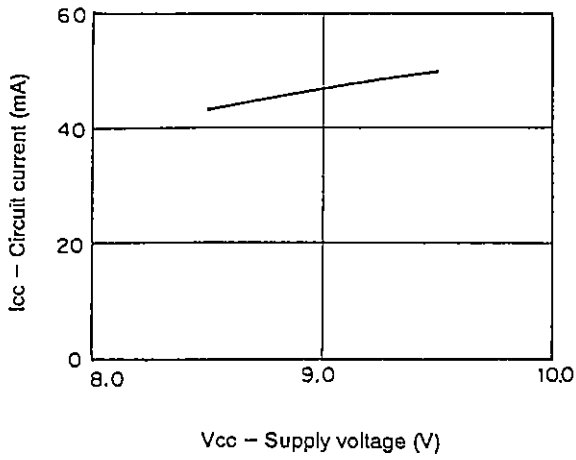

Conversion Gain vs. Reception Frequency
(Untuned Input)

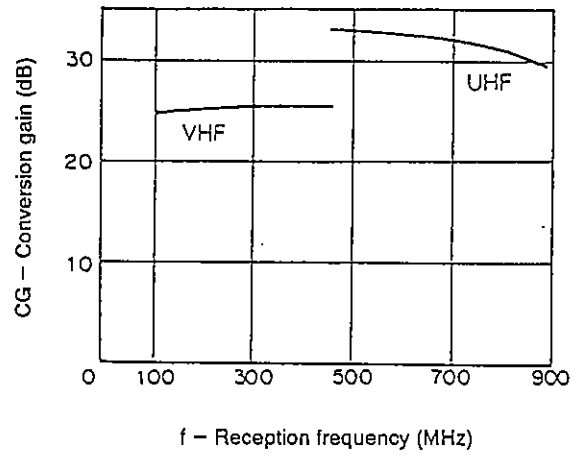

Noise Figure vs. Reception Frequency
(Untuned Input)

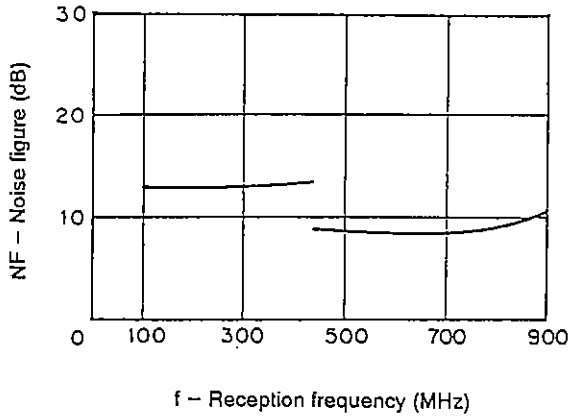

Noise Figure vs. Reception Frequency
(Tuned Input)

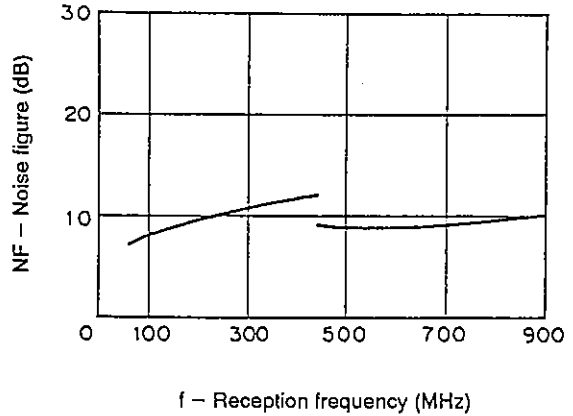

VHF Input Impedance

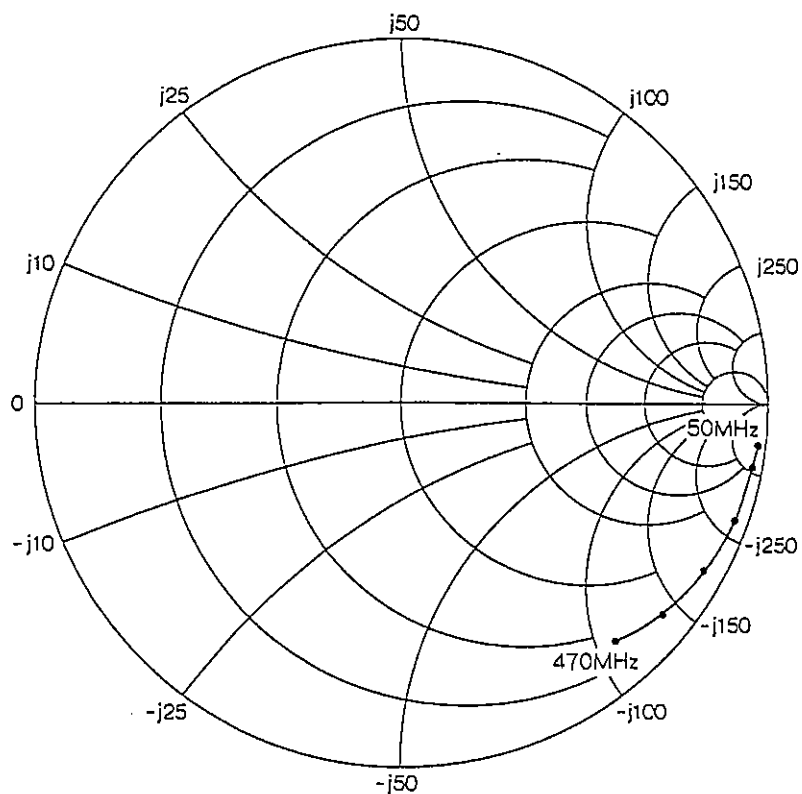

UHF Input Impedance

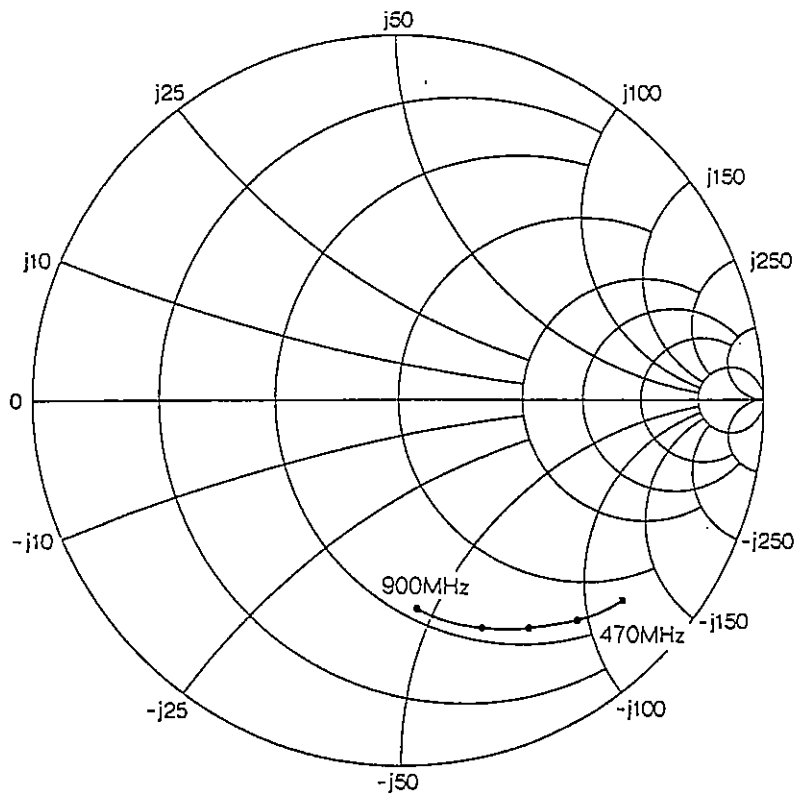

Package Outline

Unit: mm

CXA1355L

16PIN SZIP (PLASTIC)

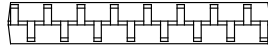
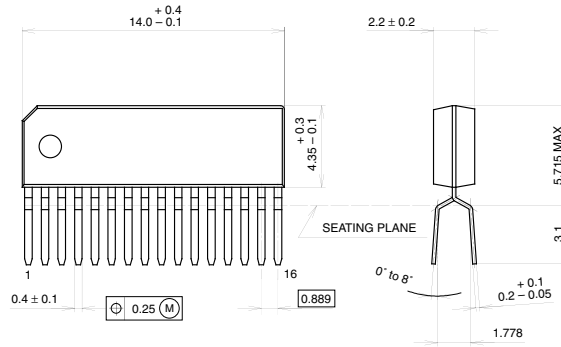

PACKAGE STRUCTURE

SONY CODE	SZIP-16P-01
EIAJ CODE	SZIP016-P-0225
JEDEC CODE	_____

PACKAGE MATERIAL	EPOXY RESIN
LEAD TREATMENT	SOLDER PLATING
LEAD MATERIAL	COPPER ALLOY
PACKAGE MASS	0.3g

16PIN SZIP (PLASTIC)

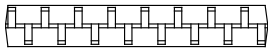
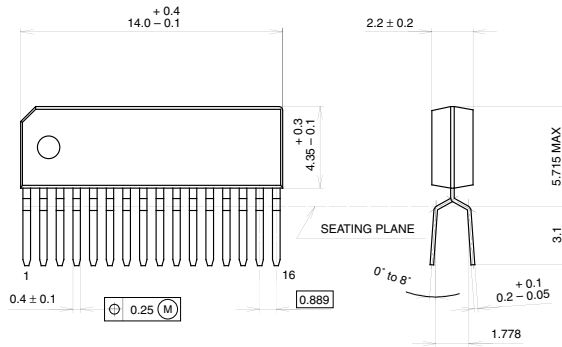

PACKAGE STRUCTURE

SONY CODE	SZIP-16P-01
EIAJ CODE	SZIP016-P-0225
JEDEC CODE	_____

PACKAGE MATERIAL	EPOXY RESIN
LEAD TREATMENT	SOLDER PLATING
LEAD MATERIAL	COPPER ALLOY
PACKAGE MASS	0.3g

LEAD PLATING SPECIFICATIONS

ITEM	SPEC.
LEAD MATERIAL	COPPER ALLOY
SOLDER COMPOSITION	Sn-Bi Bi:1-4wt%
PLATING THICKNESS	5-18µm

Package Outline

Unit: mm

CXA1355L-S

16PIN SZIP (PLASTIC)

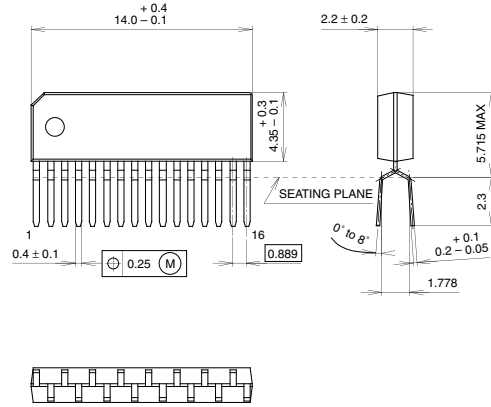

SONY CODE	SZIP-16P-02
EIAJ CODE	SZIP016-P-0225
JEDEC CODE	—————

PACKAGE STRUCTURE

PACKAGE MATERIAL	EPOXY RESIN
LEAD TREATMENT	SOLDER PLATING
LEAD MATERIAL	COPPER ALLOY
PACKAGE MASS	0.3g

16PIN SZIP (PLASTIC)

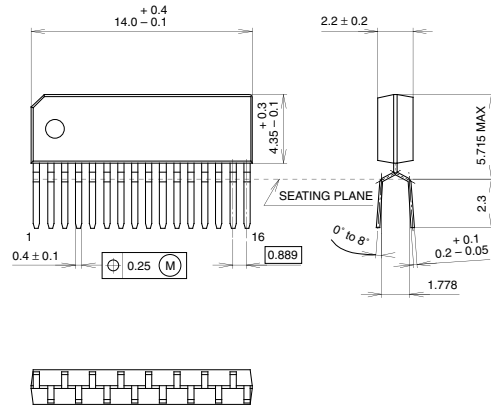

SONY CODE	SZIP-16P-02
EIAJ CODE	SZIP016-P-0225
JEDEC CODE	—————

PACKAGE STRUCTURE

PACKAGE MATERIAL	EPOXY RESIN
LEAD TREATMENT	SOLDER PLATING
LEAD MATERIAL	COPPER ALLOY
PACKAGE MASS	0.3g

LEAD PLATING SPECIFICATIONS

ITEM	SPEC.
LEAD MATERIAL	COPPER ALLOY
SOLDER COMPOSITION	Sn-Bi:1-4wt%
PLATING THICKNESS	5-18µm