

1M BIT (128K WORD x 8 BIT) CMOS MASK ROM
 SILICON GATE CMOS

DESCRIPTION

The TC531001CP/CF is a 1,048,576 bits read only memory organized as 131,072 words by 8 bits with a low bit cost, thus being suitable for use in program memory of micro-processor, and data memory, especially character generator. The TC531001CP/CF using CMOS technology is most suitable for low power applications where battery operations are required.

The TC531001CP/CF has one chip enable input \overline{CE} for device selection.

FEATURES

TC531001CP/CF	120ns Version	150ns Version
Access Time (max.)	120ns	150ns
Power Dissipation Operating Current (max.)	40mA	35mA
Power Dissipation Standby Current (max.)	20 μ A	20 μ A

- Single 5V Power Supply
- All Inputs and Outputs: TTL Compatible
- Three State Outputs
- Fully Static Operation
- Package Plastic DIP: TC531001CP
Plastic FP : TC531001CF

PIN CONNECTION

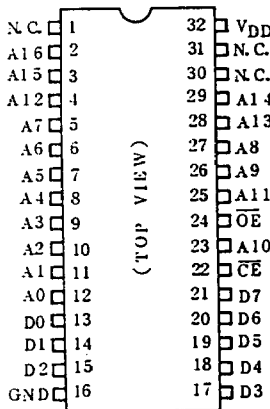

PIN NAMES

A0 ~ A16	Address Inputs
D0 ~ D7	Data Outputs
\overline{OE}	Output Enable Input
\overline{CE}	Chip Enable Input
VDD	Power Supply
GND	Ground
N.C.	No Connection

BLOCK DIAGRAM

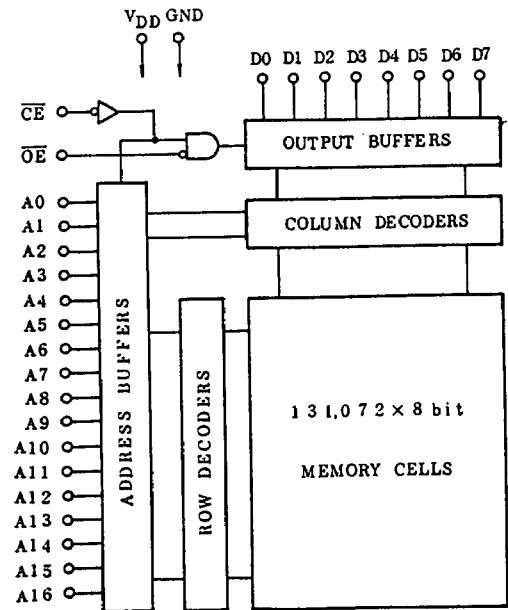

TC531001CP/CF-12/15

MAXIMUM RATINGS

SYMBOL	ITEM	RATING	UNIT
V _{DD}	Power Supply Voltage	-0.5 ~ 7.0	V
V _{IN}	Input Voltage	-0.5 ~ V _{DD}	V
V _{OUT}	Output Voltage	0 ~ V _{DD}	V
P _D	Power Dissipation	1.0/0.6 *	W
T _{STG}	Storage Temperature	-55 ~ 150	°C
T _{OPR}	Operating Temperature	-40 ~ 70	°C
T _{SOLDER}	Soldering Temperature Time	260 · 10	°C·sec

Note: * Plastic FP

DC OPERATING CONDITIONS (Ta=-40~70°C)

SYMBOL	PARAMETER	MIN.	TYP.	MAX.	UNIT
V _{DD}	Power Supply Voltage	4.5	5.0	5.5	V
V _{IH}	Input High Voltage	2.2	-	V _{DD} +0.3	
V _{IL}	Input Low Voltage	-0.3	-	0.8	

DC and OPERATING CHARACTERISTICS (Ta=-40~70°C, V_{DD}=5V±10%)

SYMBOL	PARAMETER	CONDITION	MIN.	MAX.	UNIT	
I _{IL}	Input Leakage Current	V _{IN} =0 ~ V _{DD}	-	±1.0	µA	
I _{LO}	Output Leakage Current	\overline{CE} =V _{IH} , V _{OUT} =0V ~ V _{DD}	-	±5.0	µA	
I _{OH}	Output High Current	V _{OH} =2.4V	-1.0	-	mA	
I _{OL}	Output Low Current	V _{OL} =0.4V	3.2	-	mA	
I _{DD} S1	Standby Current	\overline{CE} =2.2V	-	2	mA	
I _{DD} S2	Standby Current	\overline{CE} =V _{DD} -0.2V	-	200	µA	
I _{DD} O1	Operating Current	V _{IN} =V _{IH} /V _{IL} I _{OUT} =0mA	t _{cycle} =120ns	-	50	mA
			t _{cycle} =150ns	-	45	
I _{DD} O2		V _{IN} =V _{DD} -0.2V/0.2V I _{OUT} =0mA	t _{cycle} =120ns	-	40	
			t _{cycle} =150ns	-	35	

CAPACITANCE

SYMBOL	PARAMETER	CONDITIONS	MIN.	MAX.	UNIT
C _{IN}	Input Capacitance	f=1MHz, Ta=25°C	-	10	pF
C _{OUT}	Output Capacitance	f=1MHz, Ta=25°C	-	10	

Note: This parameter is periodically sampled and is not 100% tested.

AC CHARACTERISTICS (Ta=-40~70°C, VDD=5V±10%)

SYMBOL	PARAMETER	120ns Version		150ns Version		UNIT
		MIN.	MAX.	MIN.	MAX.	
t _{cycle}	Cycle Time	120	-	150	-	ns
t _{ACC}	Access Time	-	120	-	150	
t _{CE}	Chip Enable Access Time	-	120	-	150	
t _{OE}	Output Enable Access Time	-	70	-	70	
t _{CED}	Output Disable Time from \overline{CE}	-	50	-	50	
t _{OED}	Output Disable Time from \overline{OE}	-	50	-	50	
t _{OH}	Output Hold Time	5	-	5	-	

AC TEST CONDITIONS

- Output Load : 100pF + 1TTL
- Input Levels : 0.6V, 2.4V
- Timing Measurement Reference Levels Input: 0.8V, 2.2V
Output: 0.8V, 2.0V
- Input Rise and Fall Time : 5ns

TIMING WAVEFORMS

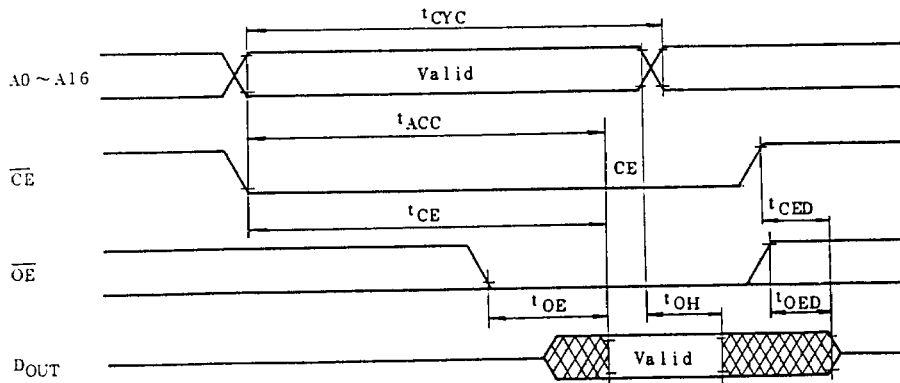

OPERATION MODE

MODE	\overline{CE}	\overline{OE}	A0 ~ 16	Outputs	Power
Read	L	L	Valid	Data Out	Operating
Standby	H	*	*	High-Z	Standby
Output Deselect	L	H	*	High-Z	Operating

H: V_{IH}, L: V_{IL}, *: V_{IH} or V_{IL}

TC531001CP/CF-12/15

OUTLINE DRAWINGS

Plastic DIP (DIP32-P-600)

Unit in mm

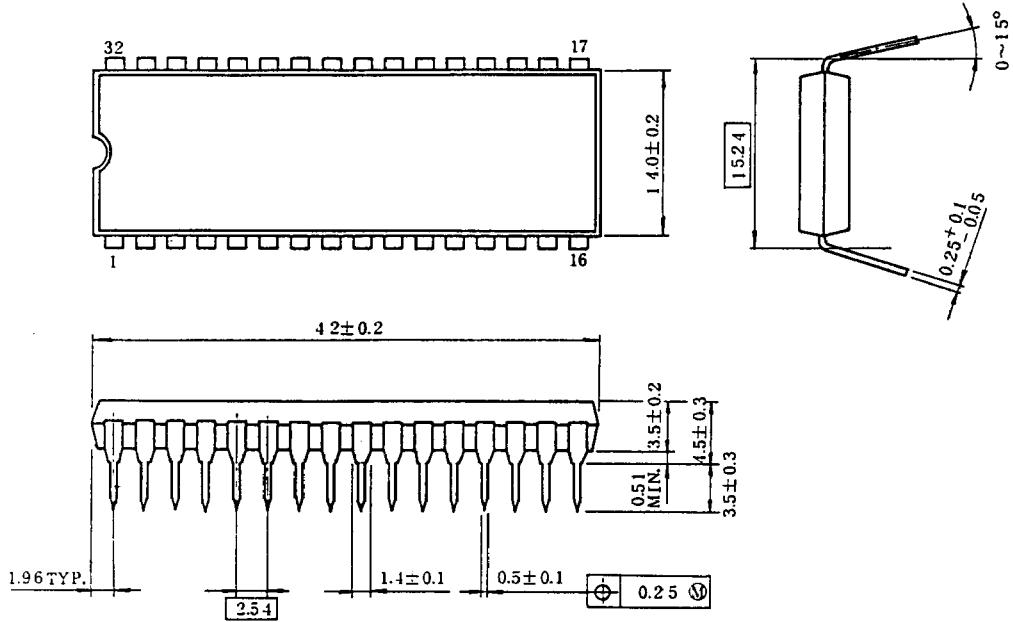

Note: Package width and length do not include mold protrusion, allowable mold protrusion is 0.15mm.

Plastic FP (SOP32-P-525)

Unit in mm

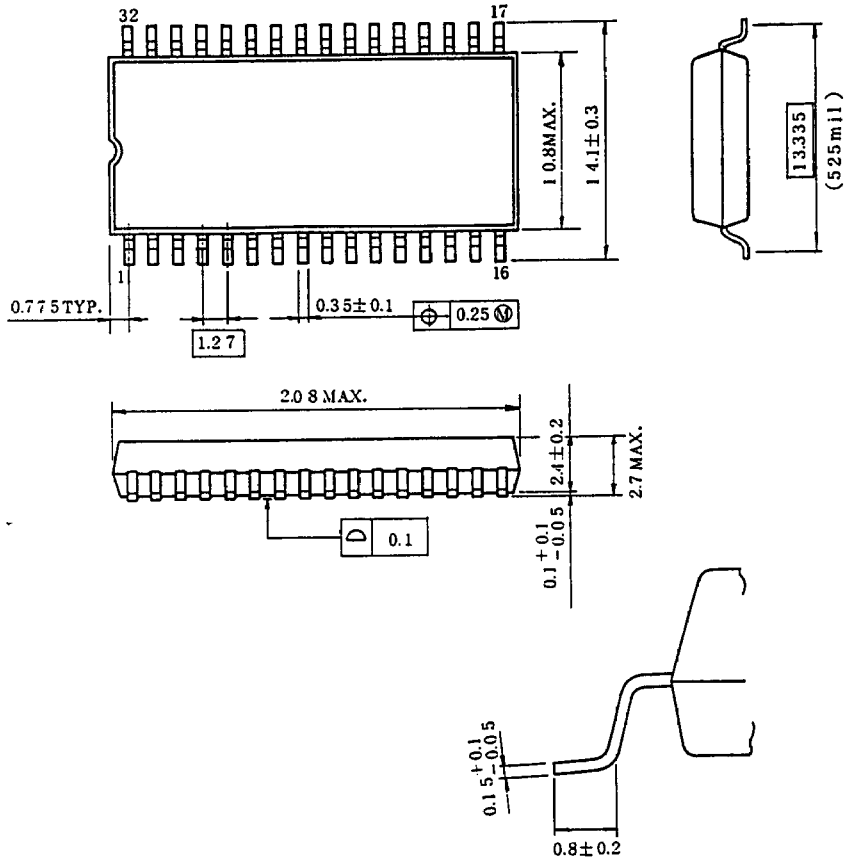

Note: Package width and length do not include mold protrusion, allowable mold protrusion is 0.15mm.