

Features

- Output voltage tolerance $\leq \pm 2\%$
- Low-drop voltage
- Very low standby current consumption
- Overtemperature protection
- Reverse polarity protection
- Short-circuit proof
- Settable reset threshold
- Watchdog
- Wide temperature range
- Suitable for use in automotive electronics

Type	Ordering Code	Package
TLE 4263 G	Q67006-A9095	P-DSO-20-6 (SMD)
▼ TLE 4263 GM	Q67006-A9357	P-DSO-14-4 (SMD)

▼ New type

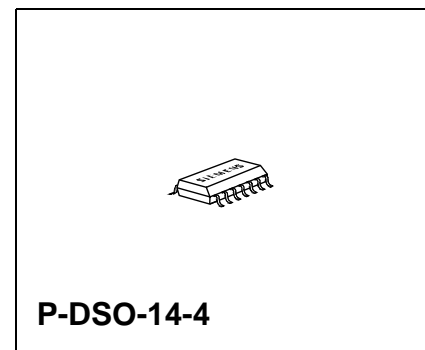
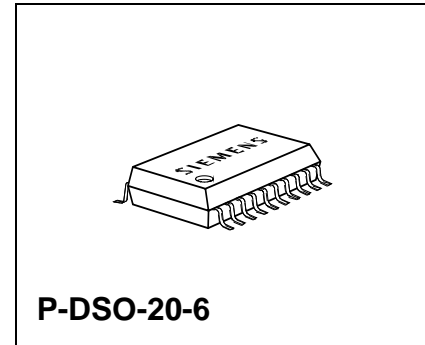

Functional Description

TLE 4263 G is a 5-V low-drop voltage regulator in a P-DSO-20-6 SMD package. The maximum input voltage is 45 V. The maximum output current is more than 200 mA. The IC is short-circuit proof and incorporates temperature protection that disables the IC at overtemperature.

The IC regulates an input voltage V_I in the range of $6\text{ V} < V_I < 45\text{ V}$ to $V_{Q\text{rated}} = 5.0\text{ V}$. A reset signal is generated for an output voltage of $V_Q < 4.5\text{ V}$. This voltage threshold can be decreased to 3.5 V by external connection. The reset delay can be set externally by a capacitor. The integrated watchdog logic controls the connected microcontroller. The IC can be switched off via the inhibit input, which causes the current consumption to drop from 800 μA to $< 50\text{ }\mu\text{A}$.

Pin Definitions and Functions

Pin	Symbol	Function
1, 2, 19, 13	N.C.	Not connected
3	QRES	Reset output ; open-collector output connected to the output via a resistor of 30 k Ω .
4-7, 14-17	GND	Ground
9	DRES	Reset delay ; connected to ground with a capacitor.
10	SRES	Reset threshold ; for setting the switching threshold connect with a voltage divider from output to ground. If this input is connected to GND, reset is triggered at an output voltage of 4.5 V.
11	W	Watchdog ; positive edge triggered input for monitoring a microcontroller.
12	V_Q	5-V output voltage ; block to ground with a 22- μ F capacitor.
18	V_I	Input voltage ; block to ground directly at the IC with a ceramic capacitor.
20	INH	Inhibit ; TTL-compatible, low-active input.

Circuit Description

The control amplifier compares a reference voltage, which is kept highly accurate by resistance adjustment, to a voltage that is proportional to the output voltage and drives the base of the series transistor via a buffer. Saturation control as a function of the load current prevents any over-saturation of the power element. If the externally scaled down output voltage at the reset threshold input drops below 1.35 V, the external reset delay capacitor is discharged by the reset generator. If the voltage on the capacitor reaches the lower threshold V_{ST} , a reset signal is issued on the reset output and not cancelled again until the upper threshold V_{dT} is exceeded. If the reset threshold input is connected to GND, reset is triggered at an output voltage of 4.5 V. A connected microcontroller is controlled by the watchdog logic. If pulses are missing, the reset output is set to low. The pulse sequence time can be set within a wide range with the reset delay capacitor. The IC can be switched at the TTL-compatible, low-active inhibit input. The IC also incorporates a number of internal circuits for protection against:

- Overload
- Overtemperature
- Reverse polarity

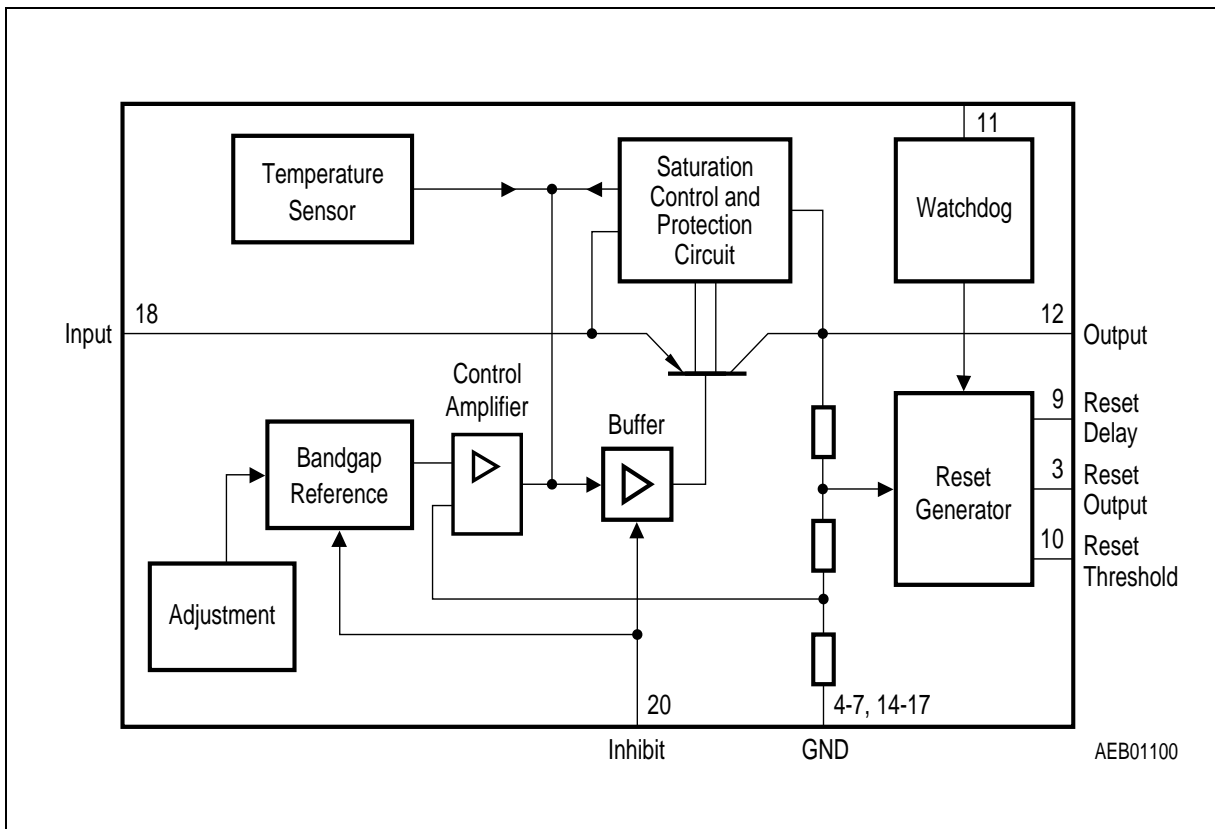

Block Diagram

Absolute Maximum Ratings $T_j = -40$ to 150 °C

Parameter	Symbol	Limit Values		Unit	Remarks
		min.	max.		

Input

Input voltage	V_I	-42	45	V	-
Input current	I_I	-	-	-	internally limited

Reset Output

Voltage	V_R	-0.3	42	V	-
Current	I_R	-	-	-	internally limited

Reset Input

Reset threshold	V_{RE}	-0.3	6	V	-
-----------------	----------	------	---	---	---

Reset Delay

Voltage	V_d	-0.3	42	V	-
Current	I_d	-	-	-	internally limited

Output

Voltage	V_Q	-0.3	7	V	-
Current	I_Q	-	-	-	internally limited

Inhibit

Voltage	V_e	-42	45	V	-
---------	-------	-----	----	---	---

Watchdog

Voltage	V_W	-0.3	6	V	-
---------	-------	------	---	---	---

Ground

Current	I_{GND}	-0.5	-	A	-
---------	-----------	------	---	---	---

Absolute Maximum Ratings (cont'd)

$T_j = -40$ to 150 °C

Parameter	Symbol	Limit Values		Unit	Remarks
		min.	max.		

Temperature

Junction temperature	T_j	–	150	°C	–
Storage temperature	T_{stg}	– 50	150	°C	–

Operating Range

Input voltage	V_I	–	45	V	–
Junction temperature	T_j	– 40	150	°C	–
Thermal resistance junction-ambient	$R_{th JA}$	–	70	K/W	soldered
junction-case	$R_{th JC}$	–	25	K/W	–

Characteristics

$V_i = 13.5\text{ V}$; $T_j = 25\text{ °C}$; $V_e > 3.5\text{ V}$; (unless specified otherwise)

Parameter	Symbol	Limit Values			Unit	Test Condition
		min.	typ.	max.		

Normal Operation

Output voltage	V_Q	4.90	5.00	5.10	V	$5\text{ mA} \leq I_Q \leq 150\text{ mA}$; $6\text{ V} \leq V_i \leq 28\text{ V}$; $-40\text{ °C} \leq T_j \leq 125\text{ °C}$
Output voltage	V_Q	4.95	5.00	5.05	V	$6\text{ V} \leq V_i \leq 32\text{ V}$; $I_Q = 100\text{ mA}$; $T_j = 100\text{ °C}$
Output current	I_Q	200	250	–	mA	–
Current consumption; $I_q = I_i - I_Q$	I_q	–	–	50	μA	$V_e = 0$
	I_q	–	800	1100	μA	$I_Q = 0\text{ mA}$
	I_q	–	10	15	mA	$I_Q = 150\text{ mA}$
	I_q	–	15	20	mA	$I_Q = 150\text{ mA}$; $V_i = 4.5\text{ V}$
Drop voltage	V_{Dr}	–	0.35	0.6	V	$I_Q = 150\text{ mA}^*)$
Load regulation	ΔV_Q	–	–	25	mV	$I_Q = 5\text{ mA to }150\text{ mA}$
Supply-voltage regulation	ΔV_Q	–	15	25	mV	$V_i = 6\text{ V to }28\text{ V}$; $I_Q = 150\text{ mA}$
Ripple rejection	SVR	–	54	–	dB	$f_r = 100\text{ Hz}$; $V_r = 0.5\text{ Vpp}$

Reset Generator

Switching threshold	V_{RT}	4.2	4.5	4.8	V	$V_{RE} = 0\text{ V}$
Switching voltage	V_{RE}	1.28	1.35	1.42	V	$V_Q > 3.5\text{ V}$
Reset low voltage	V_R	–	0.10	0.40	V	$I_R = 1\text{ mA}$

Note: The reset output is low within the range $V_Q = 1\text{ V}$ to V_{RT}

^{*)} Drop voltage = $V_i - V_Q$ (measured when the output voltage has dropped 100 mV from the nominal value obtained at 13.5 V input)

Characteristics (cont'd)

$V_i = 13.5 \text{ V}$; $T_j = 25 \text{ °C}$; $V_e > 3.5 \text{ V}$; (unless specified otherwise)

Parameter	Symbol	Limit Values			Unit	Test Condition
		min.	typ.	max.		
Saturation voltage	V_C	–	50	100	mV	$V_Q < V_{RT}$
Delay switching threshold	V_{dT}	1.5	1.7	2.1	V	–
Switching threshold	V_{ST}	0.2	0.35	0.55	V	–
Charge current	I_d	40	60	80	μA	–
Delay time	t_d	–	2.8	–	ms	$C_d = 100 \text{ nF}$
Delay time	t_t	–	2	–	μs	$C_d = 100 \text{ nF}$

Watchdog

Discharge current	I_{Cd}	4.4	6.25	8.2	μA	$V_C = 1.5 \text{ V}$
Switching voltage	V_{Cd}	1.5	1.7	2.1	V	–
Pulse time	T_W	–	22.5	–	ms	$C_d = 100 \text{ nF}$

Inhibit

Switching voltage	V_{eON}	3.5	–	–	V	IC turned on
Turn-OFF voltage	V_{eOFF}	–	–	0.8	V	IC turned off
Input current	I_e	5	10	15	μA	$V_e = 5 \text{ V}$

Note: The reset output is low within the range $V_Q = 1 \text{ V}$ to V_{RT}

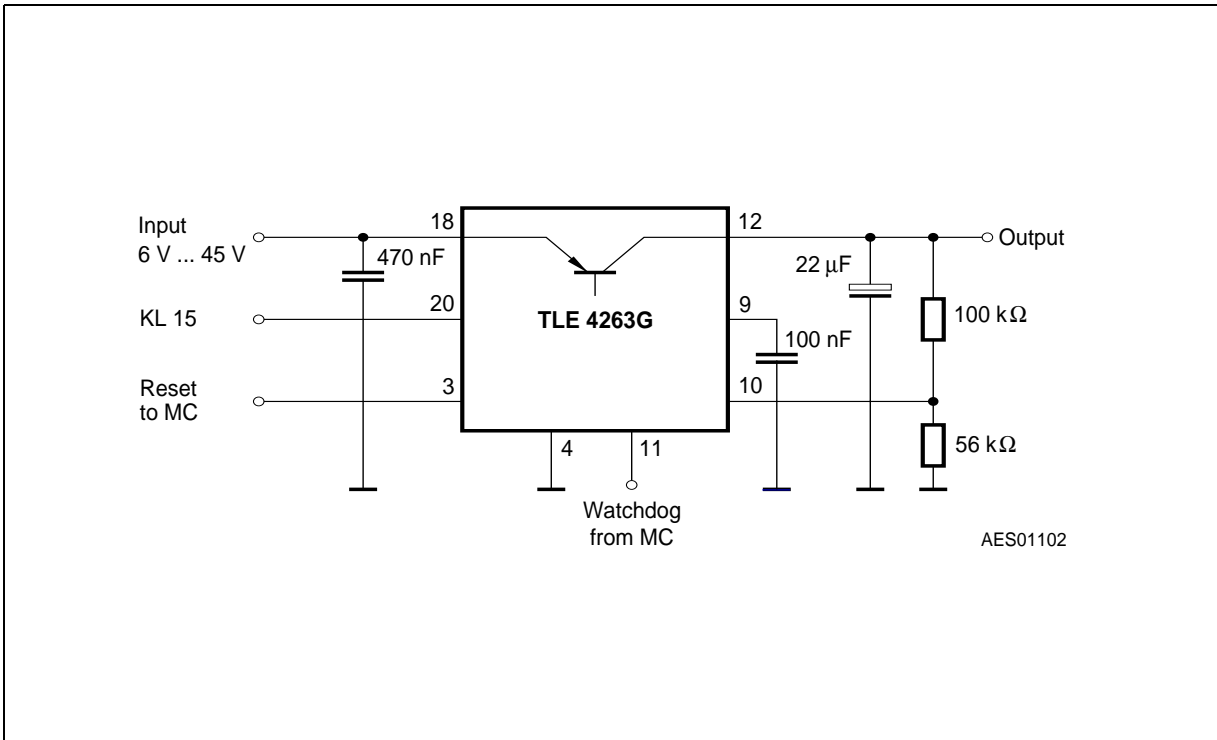

Application Circuit

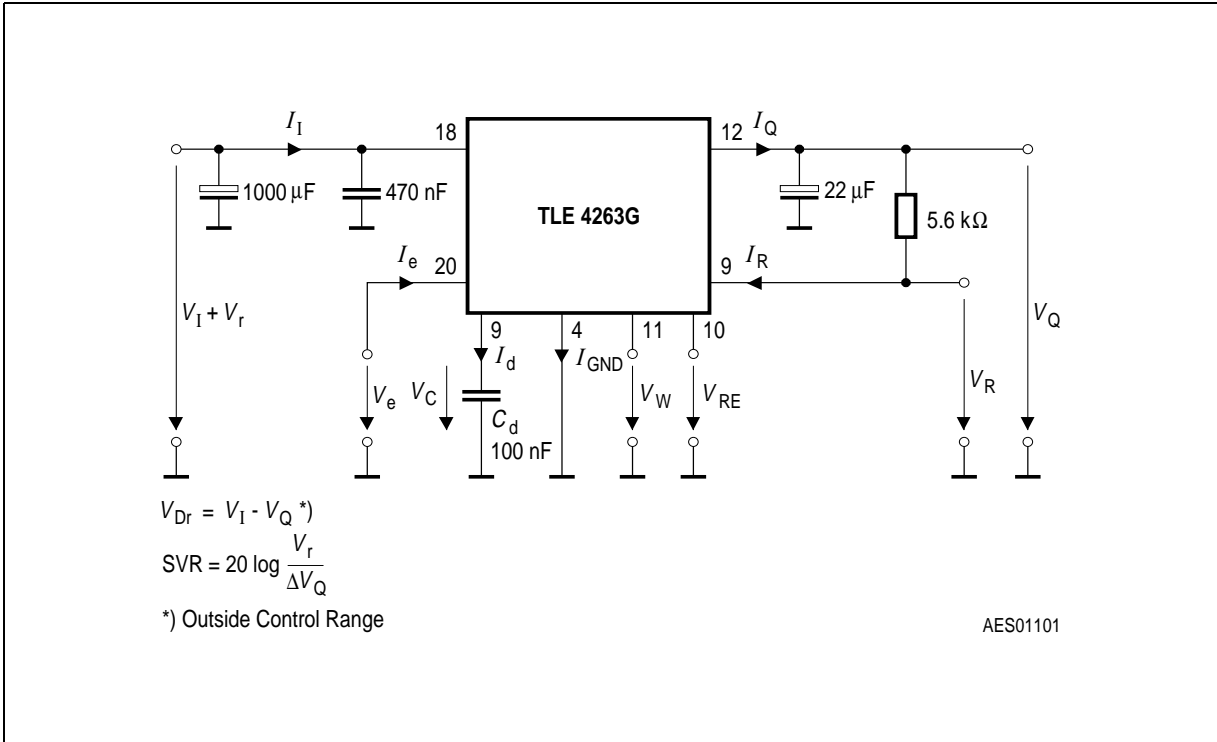

Test Circuit

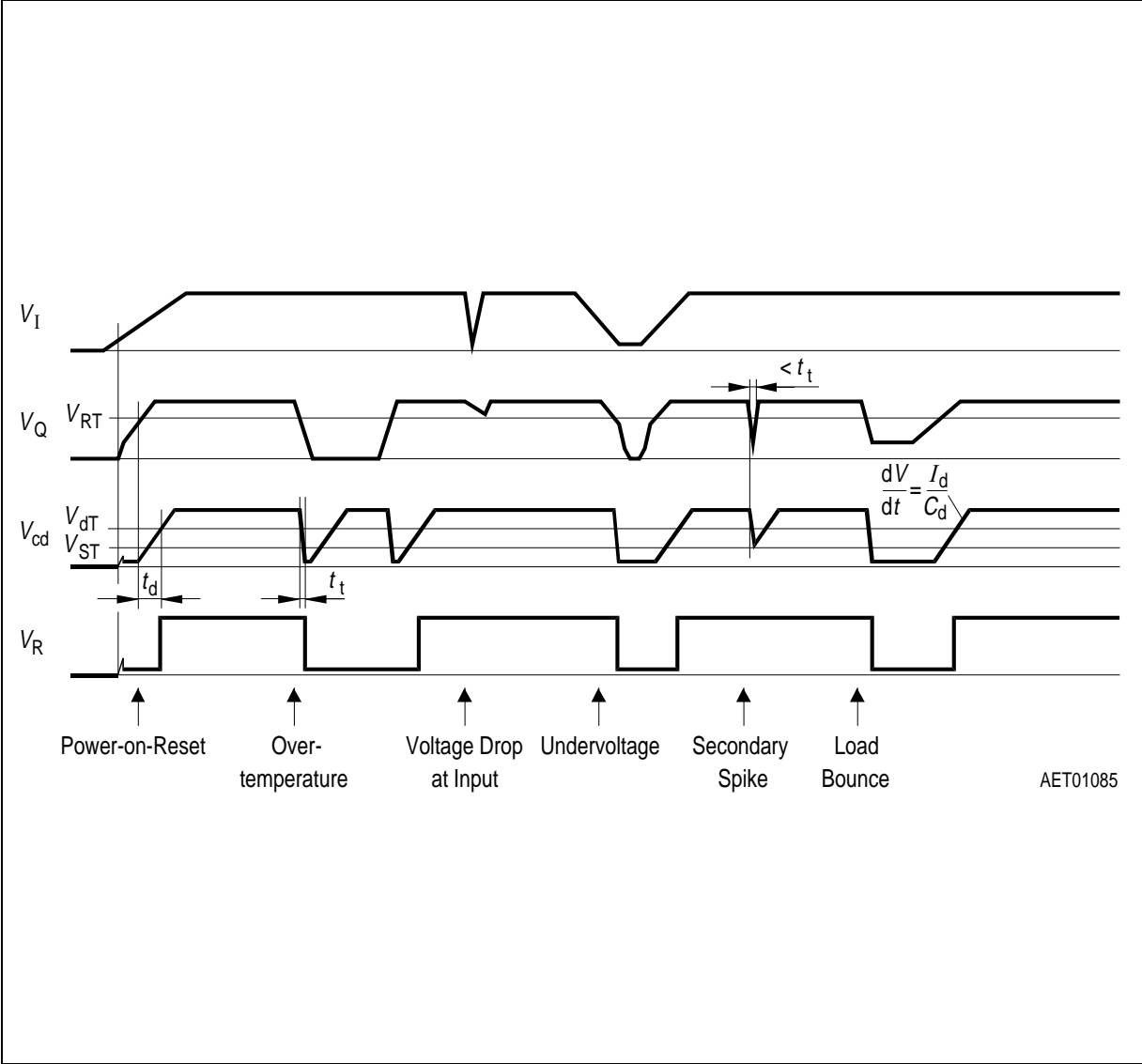

Time Response, Watchdog with High-Frequency Clock

Reset Threshold versus Output Voltage

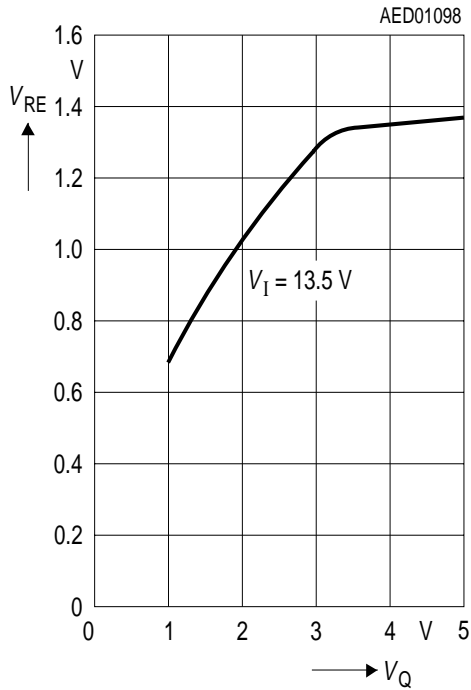

Switching Voltage V_{Cd} , V_{dT} and V_{ST} versus Temperature

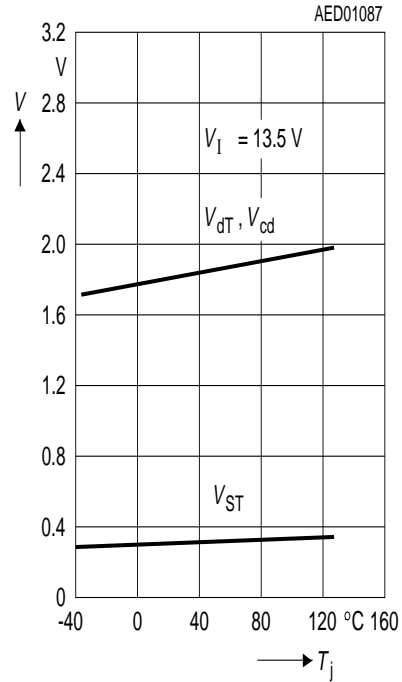

Reset Switching Threshold versus Temperature

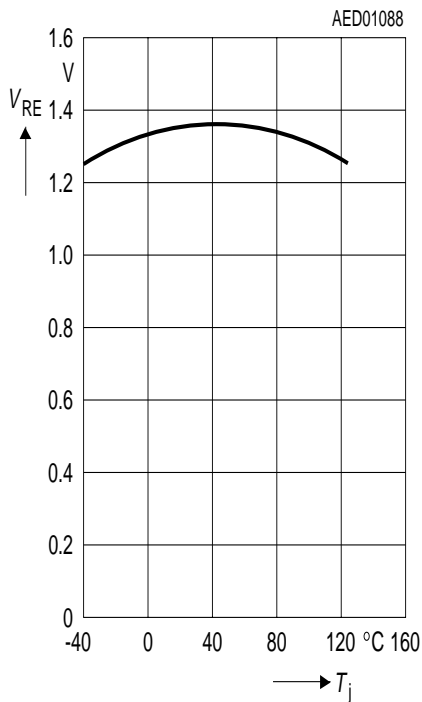

Current Consumption of Inhibit versus Temperature

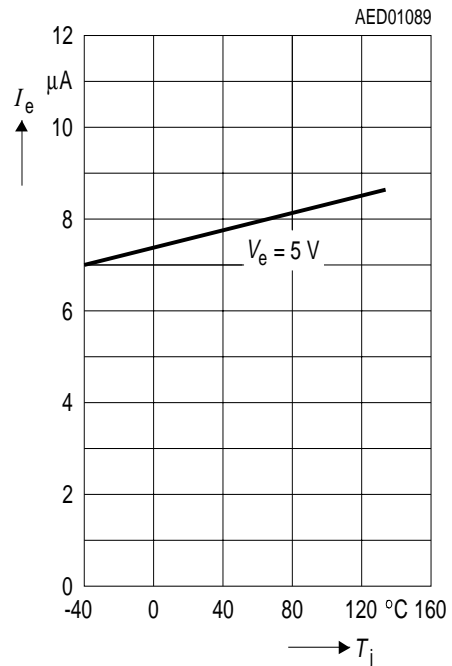

Drop Voltage versus Output Current

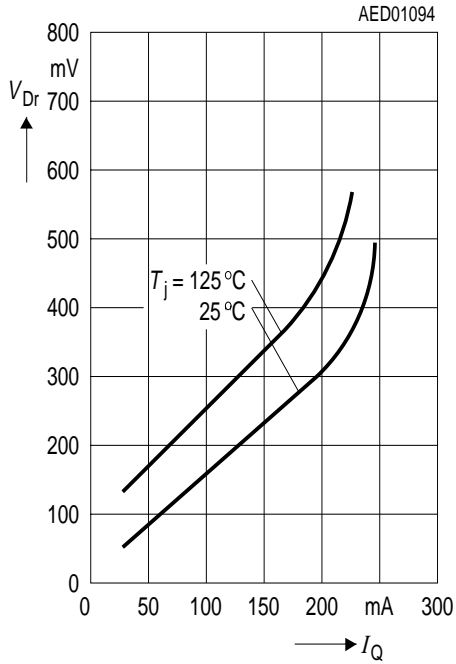

Current Consumption versus Output Current

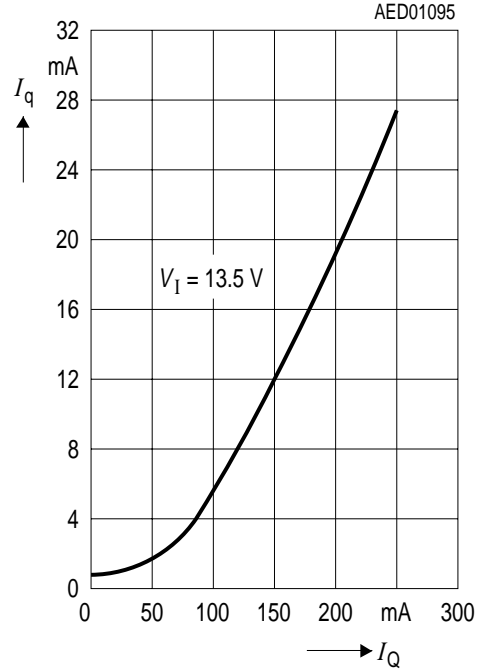

Current Consumption versus Input Voltage

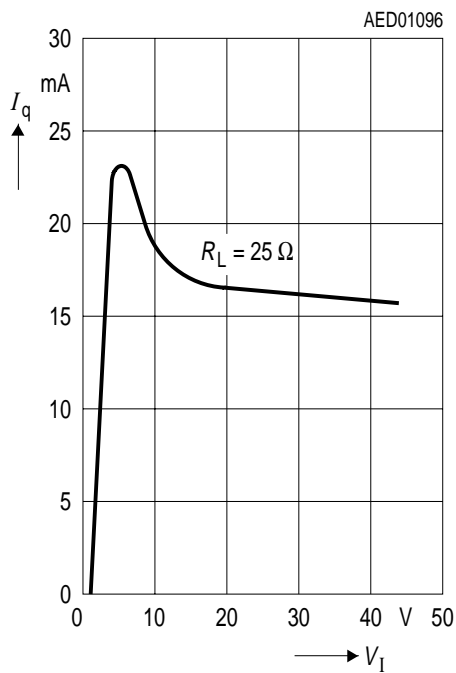

Output Voltage versus Input Voltage

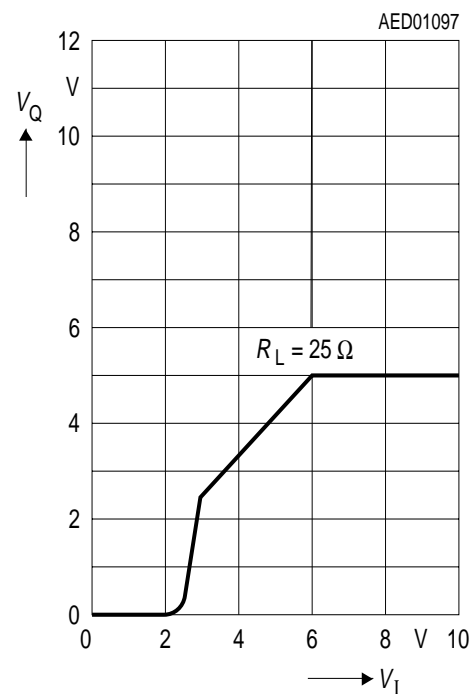

Charge Current and Discharge Current versus Temperature

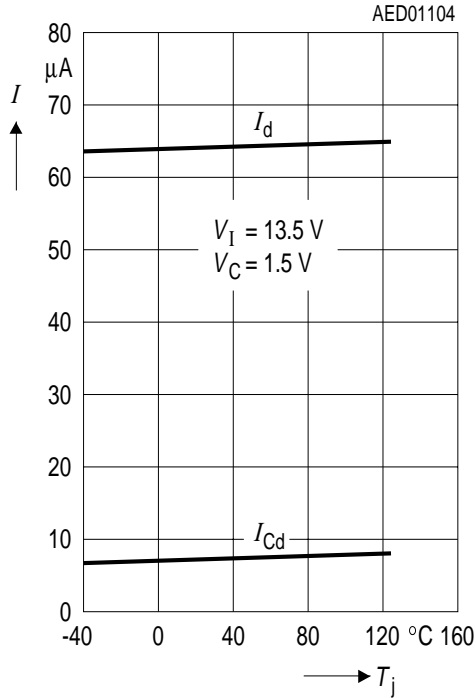

Output Voltage versus Temperature

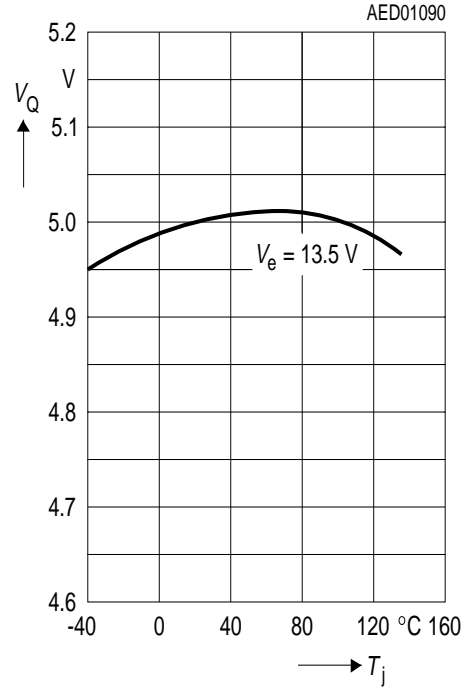

Pulse Time versus Temperature

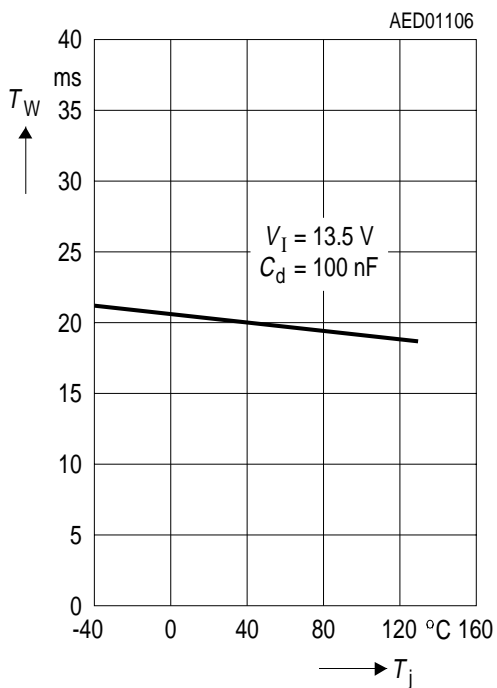

Input Response

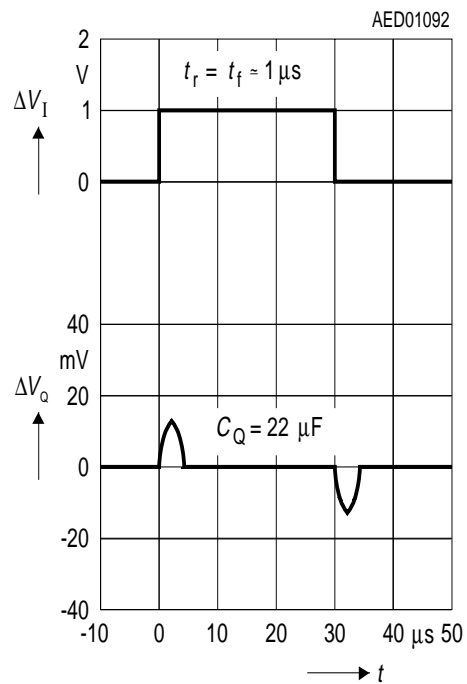

Output Current versus Input Voltage

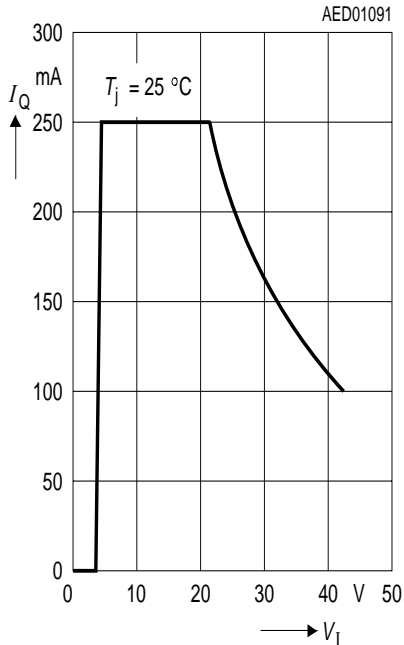

Load Response

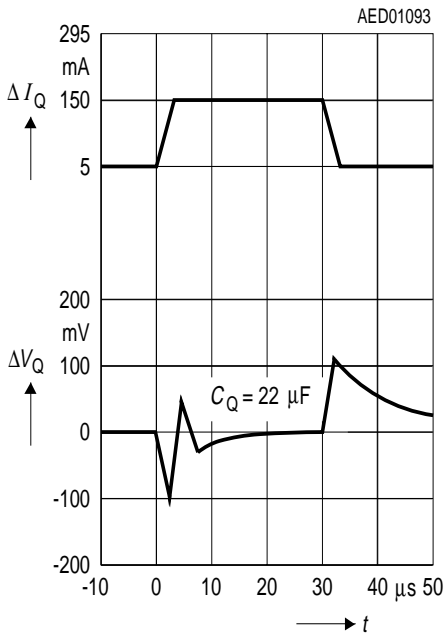

Package Outlines

P-DSO-20-6
(Plastic Dual Small Outline)

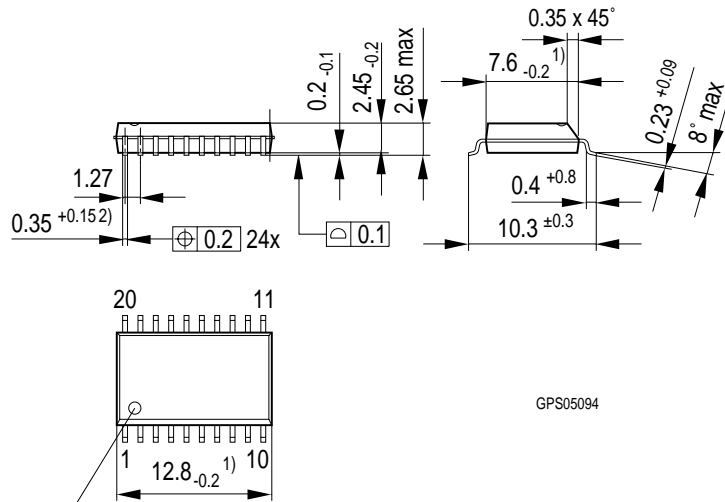

GPS05094

Index Marking

- 1) Does not include plastic or metal protrusions of 0.15 max per side
- 2) Does not include dambar protrusion of 0.05 max per side

Weight approx. 0.6 g

Sorts of Packing

Package outlines for tubes, trays etc. are contained in our Data Book "Package Information".

SMD = Surface Mounted Device

Dimensions in mm

Downloaded from Elcodis.com electronic components distributor

P-DSO-14-1
(Plastic Dual Small Outline)

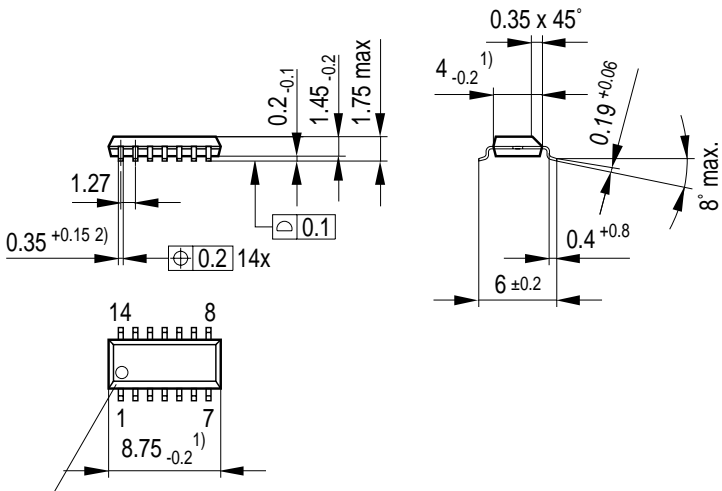

Index Marking

- 1) Does not include plastic or metal protrusion of 0.15 max. per side
- 2) Does not include dambar protrusion of 0.05 max. per side

GPS05093

Sorts of Packing

Package outlines for tubes, trays etc. are contained in our Data Book "Package Information".

SMD = Surface Mounted Device

Dimensions in mm