

The RF Sub-Micron MOSFET Line  
**RF Power Field Effect Transistors**  
N-Channel Enhancement-Mode Lateral MOSFETs

**MRF9060R1**  
**MRF9060SR1**

Designed for broadband commercial and industrial applications with frequencies up to 1.0 GHz. The high gain and broadband performance of these devices make them ideal for large-signal, common-source amplifier applications in 26 volt base station equipment.

- Typical Two-Tone Performance at 945 MHz, 26 Volts  
Output Power — 60 Watts PEP  
Power Gain — 17 dB  
Efficiency — 40%  
IMD — -31 dBc
- Integrated ESD Protection
- Designed for Maximum Gain and Insertion Phase Flatness
- Capable of Handling 10:1 VSWR, @ 26 Vdc, 945 MHz, 60 Watts CW Output Power
- Excellent Thermal Stability
- Characterized with Series Equivalent Large-Signal Impedance Parameters
- In Tape and Reel. R1 Suffix = 500 Units per 32 mm, 13 inch Reel.

**945 MHz, 60 W, 26 V**  
**LATERAL N-CHANNEL**  
**BROADBAND**  
**RF POWER MOSFETs**

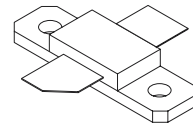

**CASE 360B-05, STYLE 1**  
**NI-360**  
**MRF9060R1**

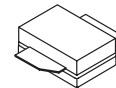

**CASE 360C-05, STYLE 1**  
**NI-360S**  
**MRF9060SR1**

**MAXIMUM RATINGS**

Rating	Symbol	Value	Unit
Drain-Source Voltage	$V_{DSS}$	65	Vdc
Gate-Source Voltage	$V_{GS}$	-0.5, +15	Vdc
Total Device Dissipation @ $T_C = 25^\circ\text{C}$ Derate above $25^\circ\text{C}$	MRF9060R1 $P_D$	159 0.91	Watts $\text{W}/^\circ\text{C}$
	MRF9060SR1	219 1.25	Watts $\text{W}/^\circ\text{C}$
Storage Temperature Range	$T_{stg}$	-65 to +200	$^\circ\text{C}$
Operating Junction Temperature	$T_J$	200	$^\circ\text{C}$

**ESD PROTECTION CHARACTERISTICS**

Test Conditions	Class
Human Body Model	1 (Minimum)
Machine Model	M1 (Minimum)

**THERMAL CHARACTERISTICS**

Characteristic	Symbol	Max	Unit
Thermal Resistance, Junction to Case	MRF9060R1 $R_{\theta JC}$	1.1	$^\circ\text{C}/\text{W}$
	MRF9060SR1	0.8	

**NOTE – CAUTION** – MOS devices are susceptible to damage from electrostatic charge. Reasonable precautions in handling and packaging MOS devices should be observed.

**ELECTRICAL CHARACTERISTICS** ( $T_C = 25^\circ\text{C}$  unless otherwise noted)

Characteristic	Symbol	Min	Typ	Max	Unit
----------------	--------	-----	-----	-----	------

**OFF CHARACTERISTICS**

Zero Gate Voltage Drain Leakage Current ( $V_{DS} = 65\text{ Vdc}$ , $V_{GS} = 0\text{ Vdc}$ )	$I_{DSS}$	—	—	10	$\mu\text{Adc}$
Zero Gate Voltage Drain Leakage Current ( $V_{DS} = 26\text{ Vdc}$ , $V_{GS} = 0\text{ Vdc}$ )	$I_{DSS}$	—	—	1	$\mu\text{Adc}$
Gate–Source Leakage Current ( $V_{GS} = 5\text{ Vdc}$ , $V_{DS} = 0\text{ Vdc}$ )	$I_{GSS}$	—	—	1	$\mu\text{Adc}$

**ON CHARACTERISTICS**

Gate Threshold Voltage ( $V_{DS} = 10\text{ Vdc}$ , $I_D = 200\ \mu\text{Adc}$ )	$V_{GS(th)}$	2	2.9	4	Vdc
Gate Quiescent Voltage ( $V_{DS} = 26\text{ Vdc}$ , $I_D = 450\text{ mAdc}$ )	$V_{GS(Q)}$	—	3.7	—	Vdc
Drain–Source On–Voltage ( $V_{GS} = 10\text{ Vdc}$ , $I_D = 1.3\text{ Adc}$ )	$V_{DS(on)}$	—	0.17	0.4	Vdc
Forward Transconductance ( $V_{DS} = 10\text{ Vdc}$ , $I_D = 4\text{ Adc}$ )	$g_{fs}$	—	5.3	—	S

**DYNAMIC CHARACTERISTICS**

Input Capacitance ( $V_{DS} = 26\text{ Vdc} \pm 30\text{ mV(rms)ac}$ @ 1 MHz, $V_{GS} = 0\text{ Vdc}$ )	$C_{iss}$	—	98	—	pF
Output Capacitance ( $V_{DS} = 26\text{ Vdc} \pm 30\text{ mV(rms)ac}$ @ 1 MHz, $V_{GS} = 0\text{ Vdc}$ )	$C_{oss}$	—	50	—	pF
Reverse Transfer Capacitance ( $V_{DS} = 26\text{ Vdc} \pm 30\text{ mV(rms)ac}$ @ 1 MHz, $V_{GS} = 0\text{ Vdc}$ )	$C_{rss}$	—	2	—	pF

(continued)

**ELECTRICAL CHARACTERISTICS — continued** ( $T_C = 25^\circ\text{C}$  unless otherwise noted)

Characteristic	Symbol	Min	Typ	Max	Unit
<b>FUNCTIONAL TESTS</b> (In Motorola Test Fixture, 50 ohm system)					
Two-Tone Common-Source Amplifier Power Gain ( $V_{DD} = 26\text{ Vdc}$ , $P_{out} = 60\text{ W PEP}$ , $I_{DQ} = 450\text{ mA}$ , $f_1 = 945.0\text{ MHz}$ , $f_2 = 945.1\text{ MHz}$ )	$G_{ps}$	16	17	—	dB
Two-Tone Drain Efficiency ( $V_{DD} = 26\text{ Vdc}$ , $P_{out} = 60\text{ W PEP}$ , $I_{DQ} = 450\text{ mA}$ , $f_1 = 945.0\text{ MHz}$ , $f_2 = 945.1\text{ MHz}$ )	$\eta$	36	40	—	%
3rd Order Intermodulation Distortion ( $V_{DD} = 26\text{ Vdc}$ , $P_{out} = 60\text{ W PEP}$ , $I_{DQ} = 450\text{ mA}$ , $f_1 = 945.0\text{ MHz}$ , $f_2 = 945.1\text{ MHz}$ )	IMD	—	-31	-28	dBc
Input Return Loss ( $V_{DD} = 26\text{ Vdc}$ , $P_{out} = 60\text{ W PEP}$ , $I_{DQ} = 450\text{ mA}$ , $f_1 = 945.0\text{ MHz}$ , $f_2 = 945.1\text{ MHz}$ )	IRL	—	-16	-9	dB
Two-Tone Common-Source Amplifier Power Gain ( $V_{DD} = 26\text{ Vdc}$ , $P_{out} = 60\text{ W PEP}$ , $I_{DQ} = 450\text{ mA}$ , $f_1 = 930.0\text{ MHz}$ , $f_2 = 930.1\text{ MHz}$ and $f_1 = 960.0\text{ MHz}$ , $f_2 = 960.1\text{ MHz}$ )	$G_{ps}$	—	17	—	dB
Two-Tone Drain Efficiency ( $V_{DD} = 26\text{ Vdc}$ , $P_{out} = 60\text{ W PEP}$ , $I_{DQ} = 450\text{ mA}$ , $f_1 = 930.0\text{ MHz}$ , $f_2 = 930.1\text{ MHz}$ and $f_1 = 960.0\text{ MHz}$ , $f_2 = 960.1\text{ MHz}$ )	$\eta$	—	39	—	%
3rd Order Intermodulation Distortion ( $V_{DD} = 26\text{ Vdc}$ , $P_{out} = 60\text{ W PEP}$ , $I_{DQ} = 450\text{ mA}$ , $f_1 = 930.0\text{ MHz}$ , $f_2 = 930.1\text{ MHz}$ and $f_1 = 960.0\text{ MHz}$ , $f_2 = 960.1\text{ MHz}$ )	IMD	—	-31	—	dBc
Input Return Loss ( $V_{DD} = 26\text{ Vdc}$ , $P_{out} = 60\text{ W PEP}$ , $I_{DQ} = 450\text{ mA}$ , $f_1 = 930.0\text{ MHz}$ , $f_2 = 930.1\text{ MHz}$ and $f_1 = 960.0\text{ MHz}$ , $f_2 = 960.1\text{ MHz}$ )	IRL	—	-16	—	dB
Power Output, 1 dB Compression Point ( $V_{DD} = 26\text{ Vdc}$ , $P_{out} = 60\text{ W CW}$ , $I_{DQ} = 450\text{ mA}$ , $f_1 = 945.0\text{ MHz}$ )	$P_{1dB}$	—	70	—	W
Common-Source Amplifier Power Gain ( $V_{DD} = 26\text{ Vdc}$ , $P_{out} = 60\text{ W CW}$ , $I_{DQ} = 450\text{ mA}$ , $f_1 = 945.0\text{ MHz}$ )	$G_{ps}$	—	17	—	dB
Drain Efficiency ( $V_{DD} = 26\text{ Vdc}$ , $P_{out} = 60\text{ W CW}$ , $I_{DQ} = 450\text{ mA}$ , $f_1 = 945.0\text{ MHz}$ )	$\eta$	—	51	—	%
Output Mismatch Stress ( $V_{DD} = 26\text{ Vdc}$ , $P_{out} = 60\text{ W CW}$ , $I_{DQ} = 450\text{ mA}$ , $f = 945.0\text{ MHz}$ , $VSWR = 10:1$ , All Phase Angles at Frequency of Tests)	$\Psi$	No Degradation In Output Power			

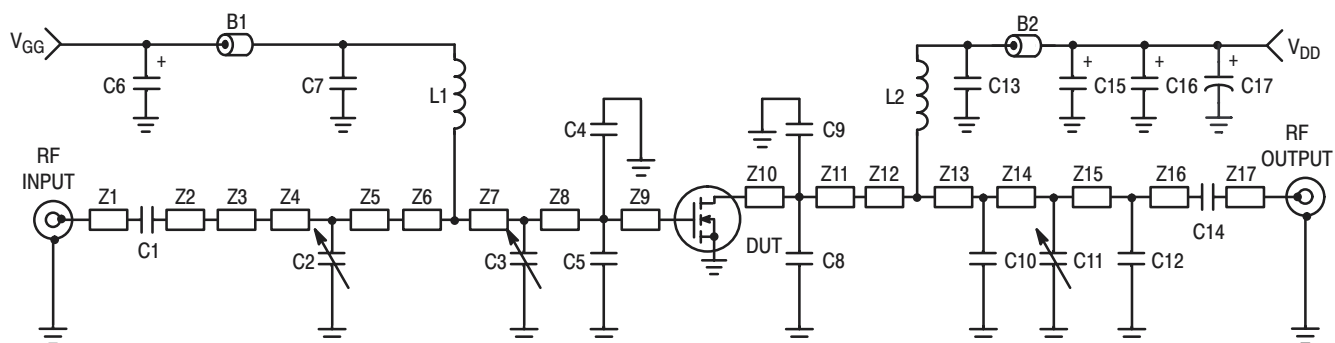

Z1	0.240" x 0.060" Microstrip	Z10	0.360" x 0.270" Microstrip
Z2	0.240" x 0.060" Microstrip	Z11	0.060" x 0.270" Microstrip
Z3	0.500" x 0.100" Microstrip	Z12	0.110" x 0.060" Microstrip
Z4	0.180" x 0.270" Microstrip	Z13	0.330" x 0.060" Microstrip
Z5	0.350" x 0.270" Microstrip	Z14	0.230" x 0.060" Microstrip
Z6	0.270" x 0.520 x 0.140" Taper	Z15	0.740" x 0.060" Microstrip
Z7	0.170" x 0.520" Microstrip	Z16	0.130" x 0.060" Microstrip
Z8	0.410" x 0.520" Microstrip	Z17	0.340" x 0.060" Microstrip
Z9	0.060" x 0.520" Microstrip		

**Figure 1. 945 MHz Broadband Test Circuit Schematic**

**Table 1. 945 MHz Broadband Test Circuit Component Designations and Values**

Part	Description	Value, P/N or DWG	Manufacturer
B1	Short Ferrite Bead	95F786	Newark
B2	Long Ferrite Bead	95F787	Newark
C1, C7, C13, C14	47 pF Chip Capacitors, B Case	100B470JP 500X	ATC
C2, C3, C11	0.8–8.0 Gigatrim Variable Capacitors	44F3360	Newark
C4, C5, C8, C9	10 pF Chip Capacitors, B Case	100B100JP 500X	ATC
C6, C15, C16	10 μF, 35 V Tantalum Chip Capacitor	93F2975	Newark
C10	3.0 pF Chip Capacitor, B Case	100B3R0JP 500X	ATC
C12	0.5 pF Chip Capacitor, B Case (MRF9060) 0.7 pF Chip Capacitor, B Case (MRF9060S)	100B0R5BP 500X 100B0R7BP 500X	ATC ATC
C17	220 μF Electrolytic Chip Capacitor	14F185	Newark
L1, L2	12.5 nH Inductors	A04T–5	Coilcraft
N1, N2	N–Type Panel Mount, Stripline	3052–1648–10	Avnet
WB1, WB2	10 mil Brass Wear Blocks		
Board Material	30 mil Glass Teflon <sup>®</sup> , ε <sub>r</sub> = 3.55 Copper Clad, 1 oz Cu	RF–35–0300	Taconic
PCB	Etched Circuit Board	MRF9060 900 MHz, Rev. 2	

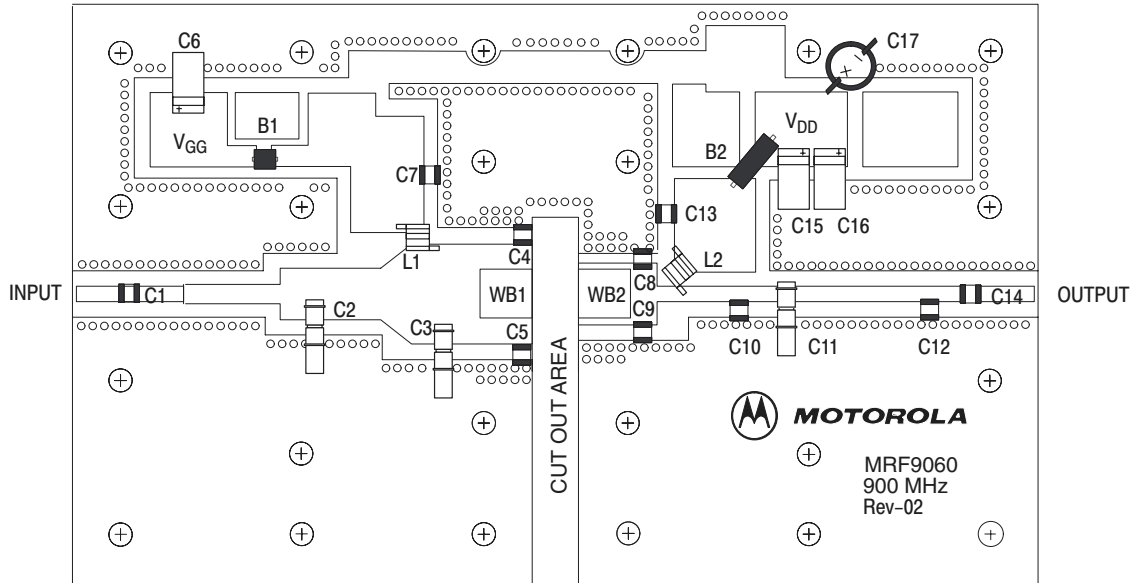

Figure 2. 930 – 960 MHz Broadband Test Circuit Component Layout

## TYPICAL CHARACTERISTICS

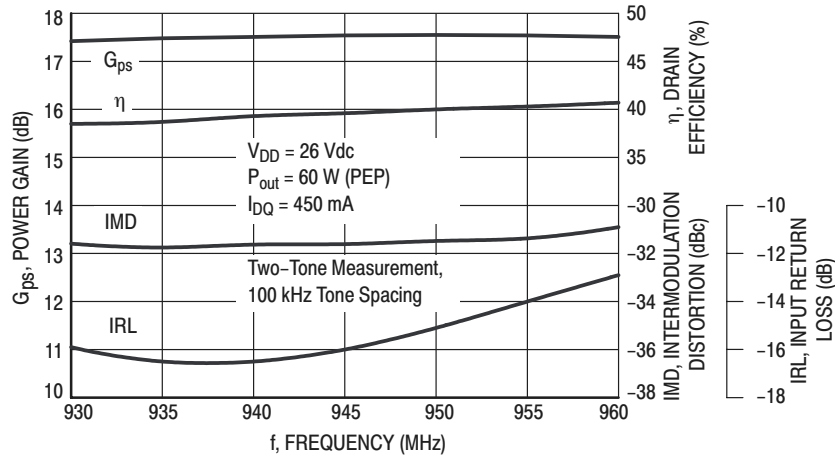

Figure 3. Class AB Broadband Circuit Performance

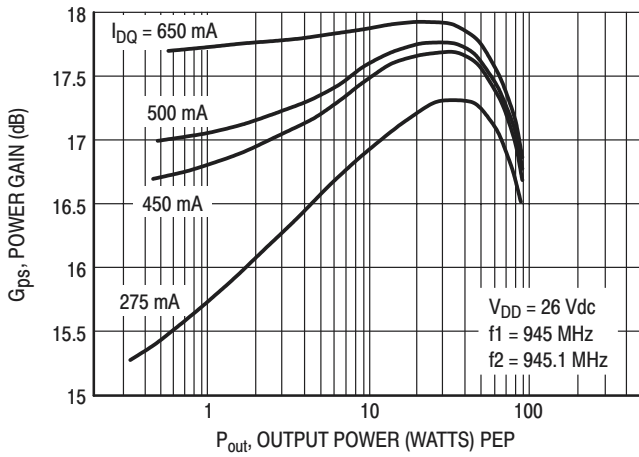

Figure 4. Power Gain versus Output Power

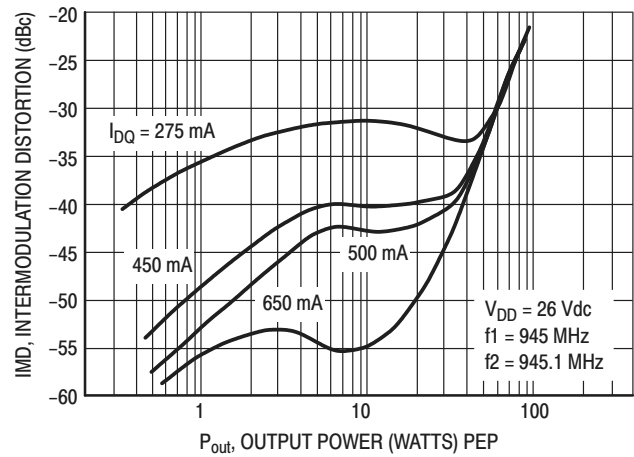

Figure 5. Intermodulation Distortion versus Output Power

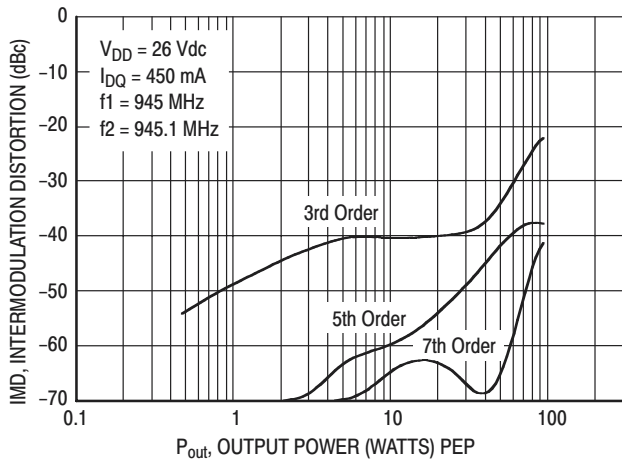

Figure 6. Intermodulation Distortion Products versus Output Power

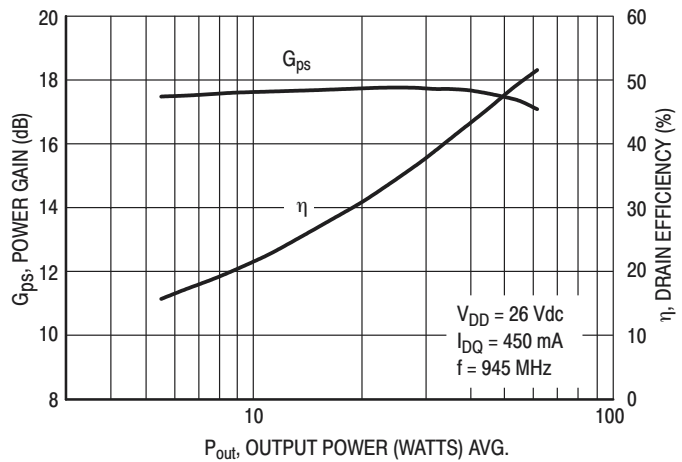
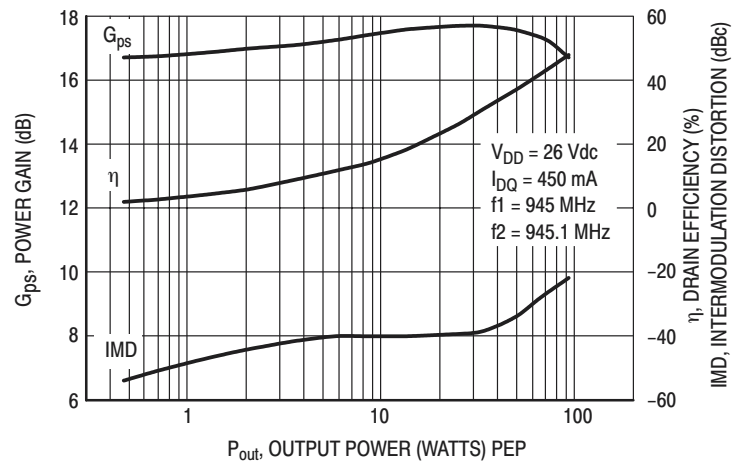
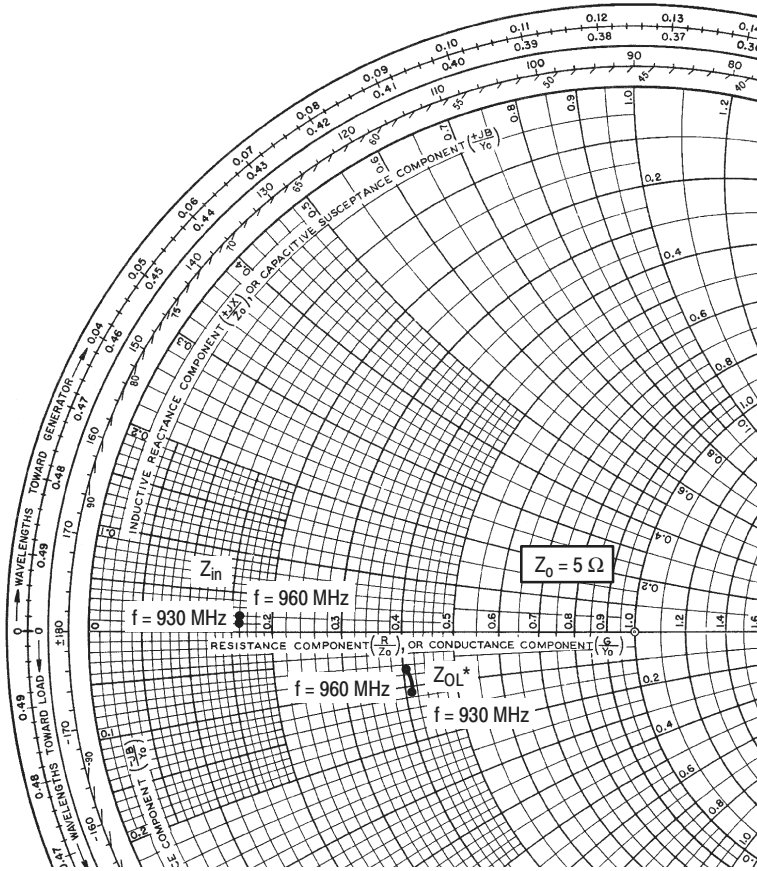

Figure 7. Power Gain and Efficiency versus Output Power



**Figure 8. Power Gain, Efficiency, and IMD versus Output Power**



$V_{DD} = 26\text{ V}$ ,  $I_{DQ} = 450\text{ mA}$ ,  $P_{out} = 60\text{ W PEP}$

f MHz	$Z_{in}$ $\Omega$	$Z_{OL}^*$ $\Omega$
930	$0.80 + j0.10$	$2.08 - j0.65$
945	$0.80 + j0.05$	$2.07 - j0.38$
960	$0.81 + j0.10$	$2.04 - j0.37$

$Z_{in}$  = Complex conjugate of source impedance.

$Z_{OL}^*$  = Complex conjugate of the optimum load impedance at a given output power, voltage, IMD, bias current and frequency.

Note:  $Z_{OL}^*$  was chosen based on tradeoffs between gain, output power, drain efficiency and intermodulation distortion.

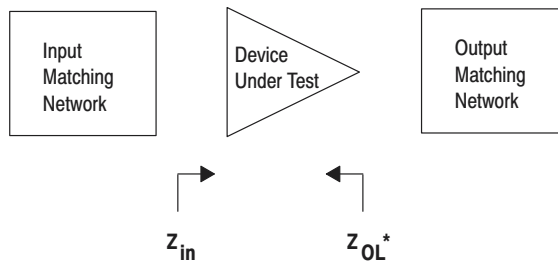

Figure 9. Series Equivalent Input and Output Impedance



# NOTES

# NOTES

## PACKAGE DIMENSIONS

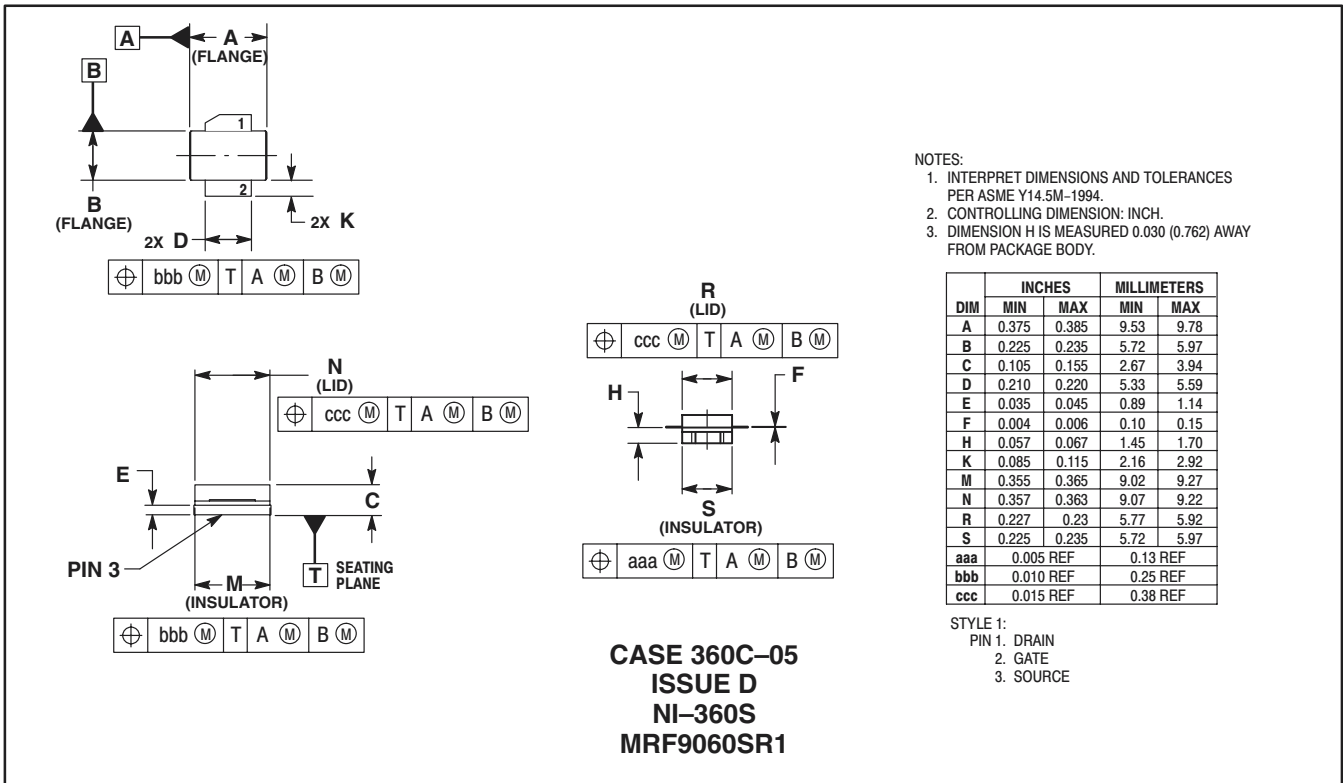
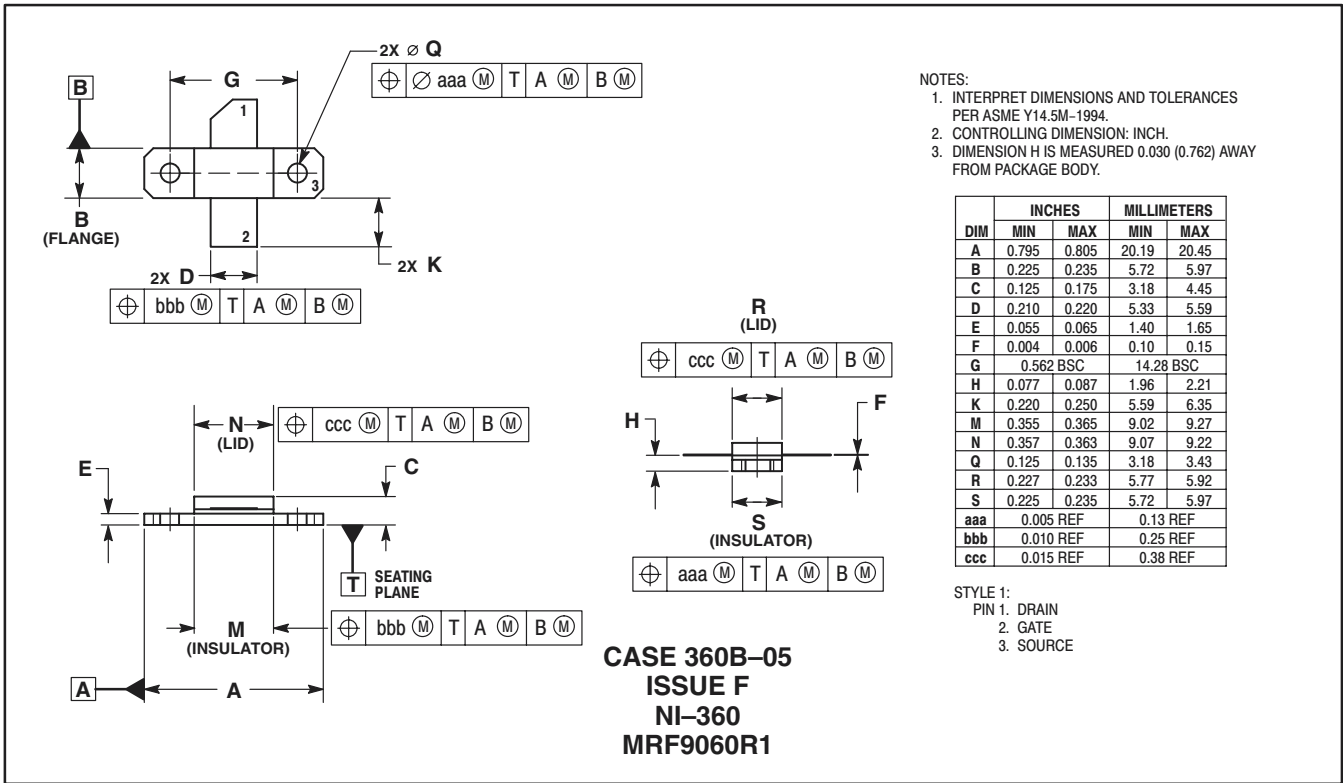

Motorola reserves the right to make changes without further notice to any products herein. Motorola makes no warranty, representation or guarantee regarding the suitability of its products for any particular purpose, nor does Motorola assume any liability arising out of the application or use of any product or circuit, and specifically disclaims any and all liability, including without limitation consequential or incidental damages. "Typical" parameters which may be provided in Motorola data sheets and/or specifications can and do vary in different applications and actual performance may vary over time. All operating parameters, including "Typicals" must be validated for each customer application by customer's technical experts. Motorola does not convey any license under its patent rights nor the rights of others. Motorola products are not designed, intended, or authorized for use as components in systems intended for surgical implant into the body, or other applications intended to support or sustain life, or for any other application in which the failure of the Motorola product could create a situation where personal injury or death may occur. Should Buyer purchase or use Motorola products for any such unintended or unauthorized application, Buyer shall indemnify and hold Motorola and its officers, employees, subsidiaries, affiliates, and distributors harmless against all claims, costs, damages, and expenses, and reasonable attorney fees arising out of, directly or indirectly, any claim of personal injury or death associated with such unintended or unauthorized use, even if such claim alleges that Motorola was negligent regarding the design or manufacture of the part. Motorola, Inc. Motorola, Inc. is an Equal Opportunity/Affirmative Action Employer. MOTOROLA and the  logo are registered in the US Patent & Trademark Office. All other product or service names are the property of their respective owners.

© Motorola, Inc. 2002.

**How to reach us:**

**USA/EUROPE/Locations Not Listed:** Motorola Literature Distribution; P.O. Box 5405, Denver, Colorado 80217. 1-303-675-2140 or 1-800-441-2447

**JAPAN:** Motorola Japan Ltd.; SPS, Technical Information Center, 3-20-1, Minami-Azabu. Minato-ku, Tokyo 106-8573 Japan. 81-3-3440-3569

**ASIA/PACIFIC:** Motorola Semiconductors H.K. Ltd.; Silicon Harbour Centre, 2 Dai King Street, Tai Po Industrial Estate, Tai Po, N.T., Hong Kong. 852-26668334

**Technical Information Center: 1-800-521-6274**

**HOME PAGE:** <http://www.motorola.com/semiconductors/>



MRF9060/D