HM5164165F Series

HM5165165F Series

64M EDO DRAM (4-Mword × 16-bit)
8k refresh/4k refresh

HITACHI

ADE-203-1058B(Z)

Rev. 2.0

Nov. 30, 1999

Description

The Hitachi HM5164165F Series, HM5165165F Series are 64M-bit dynamic RAMs organized as 4,194,304-word × 16-bit. They have realized high performance and low power by employing CMOS process technology. HM5164165F Series, HM5165165F Series offer Extended Data Out (EDO) Page Mode as a high speed access mode. They have the package variations of standard 50-pin plastic SOJ and standard 50-pin plastic TSOPII

Features

- Single 3.3 V supply: 3.3 V ± 0.3 V
- Access time: 50 ns/60 ns (max)
- Power dissipation
 - Active: 432 mW/396 mW (max) (HM5164165F Series)
: 504 mW/432 mW (max) (HM5165165F Series)
 - Standby : 1.8 mW (max) (CMOS interface)
: 1.1 mW (max) (L-version)
- EDO page mode capability
- Refresh cycles
 - $\overline{\text{RAS}}$ -only refresh
 - 8192 cycles/64 ms (HM5164165F, HM5164165FL)
 - 4096 cycles/64 ms (HM5165165F, HM5165165FL)
 - CBR/Hidden refresh
 - 4096 cycles/64 ms (HM5164165F, HM5164165FL, HM5165165F, HM5165165FL)

HM5164165F Series, HM5165165F Series

- 4 variations of refresh
 - $\overline{\text{RAS}}$ -only refresh
 - $\overline{\text{CAS}}$ -before- $\overline{\text{RAS}}$ refresh
 - Hidden refresh
 - Self refresh (L-version)
- $2\overline{\text{CAS}}$ -byte control
- Battery backup operation (L-version)

Ordering Information

Type No.	Access time	Package
HM5164165FJ-5	50 ns	400-mil 50-pin plastic SOJ (CP-50DA)
HM5164165FJ-6	60 ns	
HM5164165FLJ-5	50 ns	
HM5164165FLJ-6	60 ns	
HM5165165FJ-5	50 ns	
HM5165165FJ-6	60 ns	
HM5165165FLJ-5	50 ns	
HM5165165FLJ-6	60 ns	
HM5164165FTT-5	50 ns	400-mil 50-pin plastic TSOP II (TTP-50DB)
HM5164165FTT-6	60 ns	
HM5164165FLTT-5	50 ns	
HM5164165FLTT-6	60 ns	
HM5165165FTT-5	50 ns	
HM5165165FTT-6	60 ns	
HM5165165FLTT-5	50 ns	
HM5165165FLTT-6	60 ns	

Pin Arrangement (HM5164165F Series)

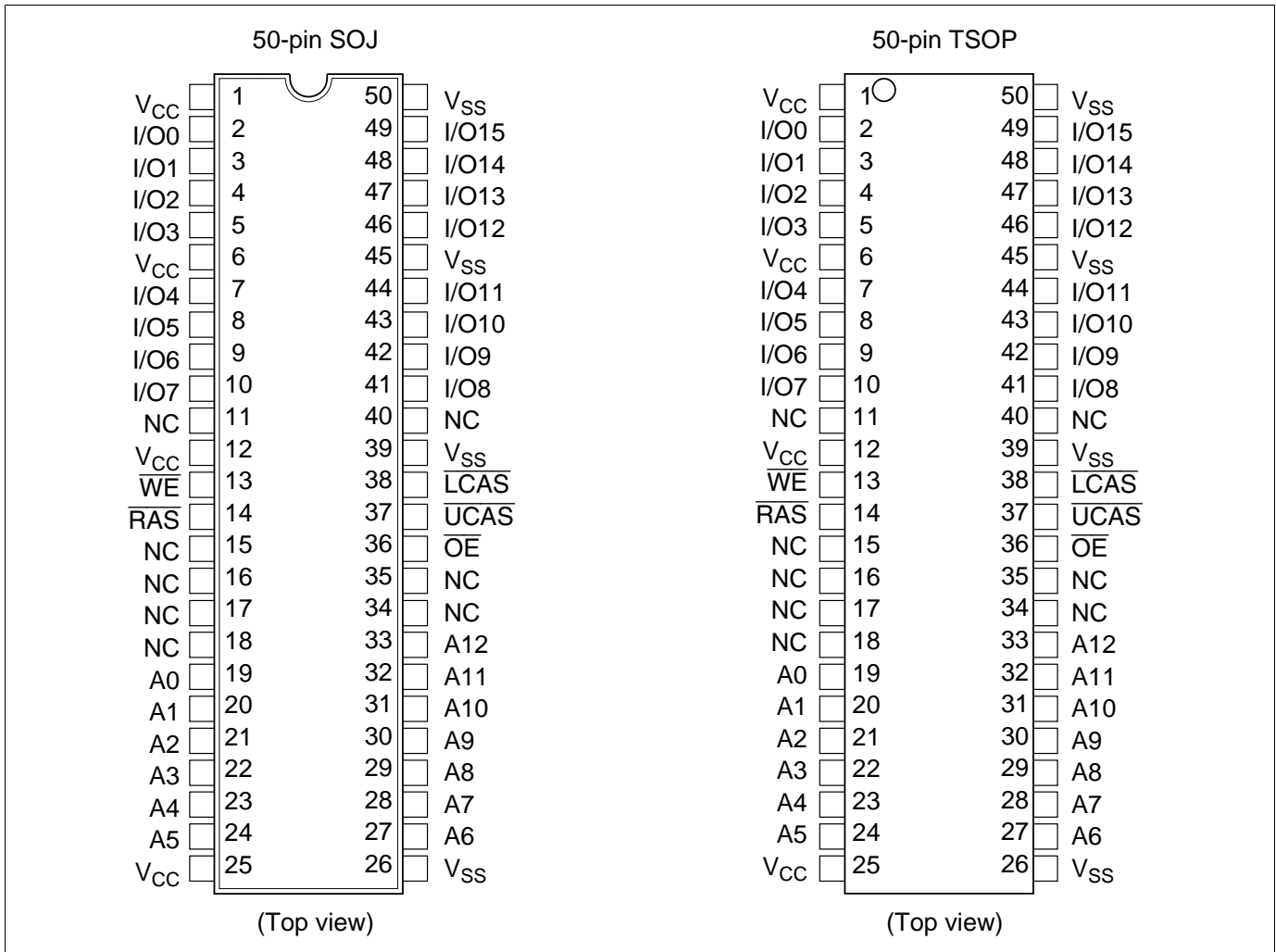

Pin Description

Pin name	Function
A0 to A12	Address input — Row/Refresh address A0 to A12 — Column address A0 to A8
I/O0 to I/O15	Data input/output
RAS	Row address strobe
UCAS, LCAS	Column address strobe
WE	Write enable
OE	Output enable
V _{CC}	Power supply
V _{SS}	Ground
NC	No connection

Pin Arrangement (HM5165165F Series)

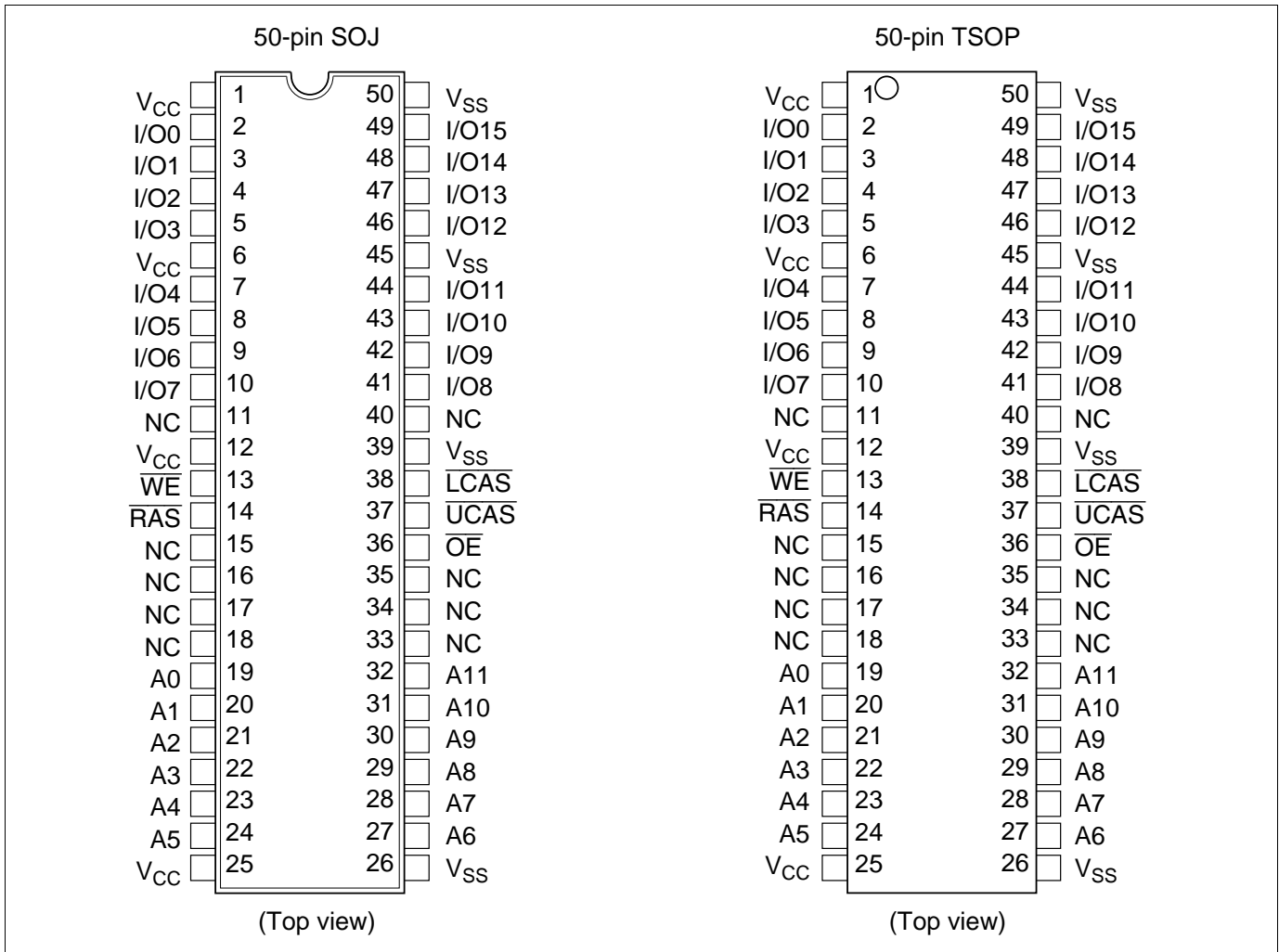

Pin Description

Pin name	Function
A0 to A11	Address input — Row/Refresh address A0 to A11 — Column address A0 to A9
I/O0 to I/O15	Data input/output
$\overline{\text{RAS}}$	Row address strobe
$\overline{\text{UCAS}}$, $\overline{\text{LCAS}}$	Column address strobe
$\overline{\text{WE}}$	Write enable
$\overline{\text{OE}}$	Output enable
V _{CC}	Power supply
V _{SS}	Ground
NC	No connection

Block Diagram (HM5164165F Series)

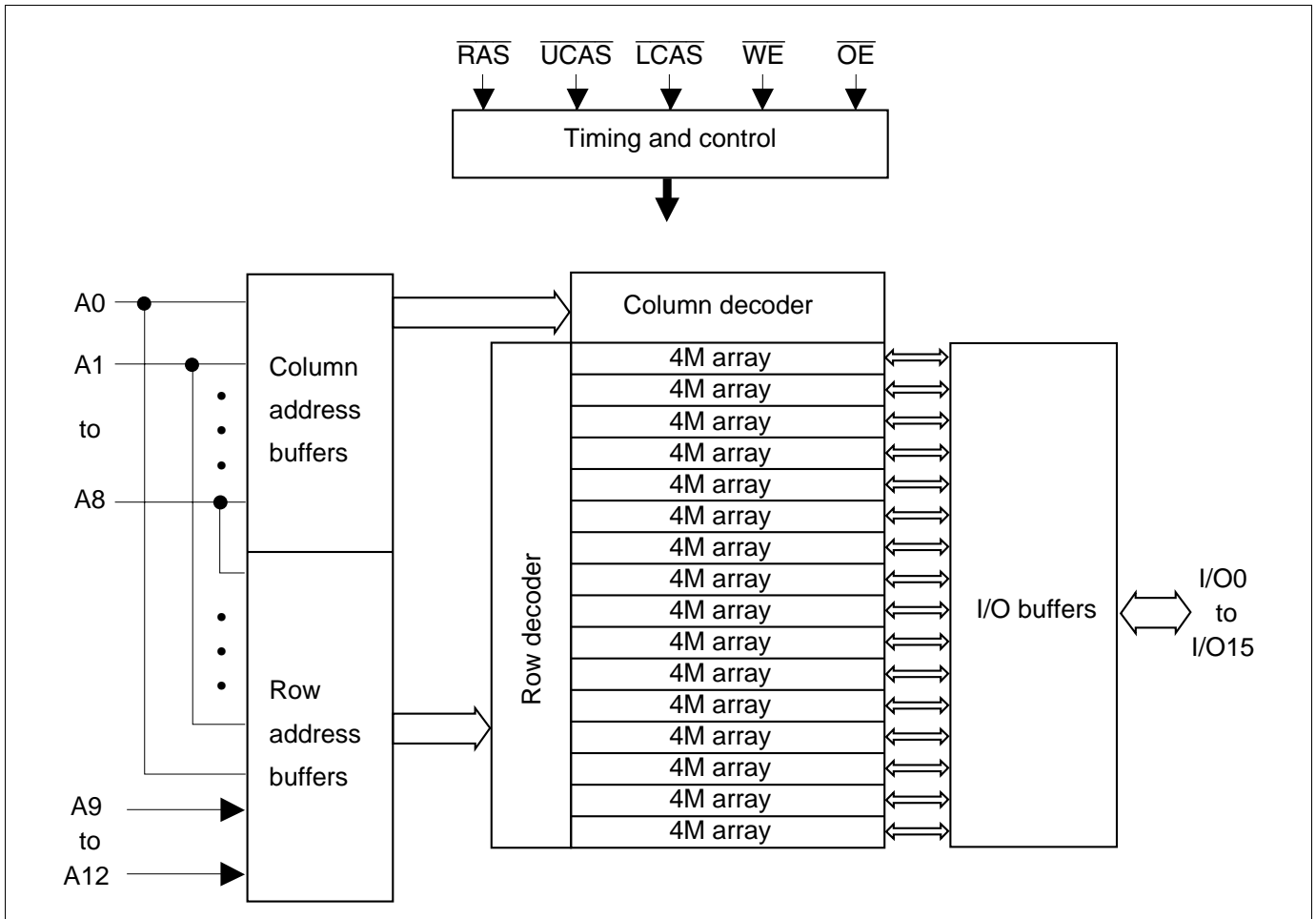

Block Diagram (HM5165165F Series)

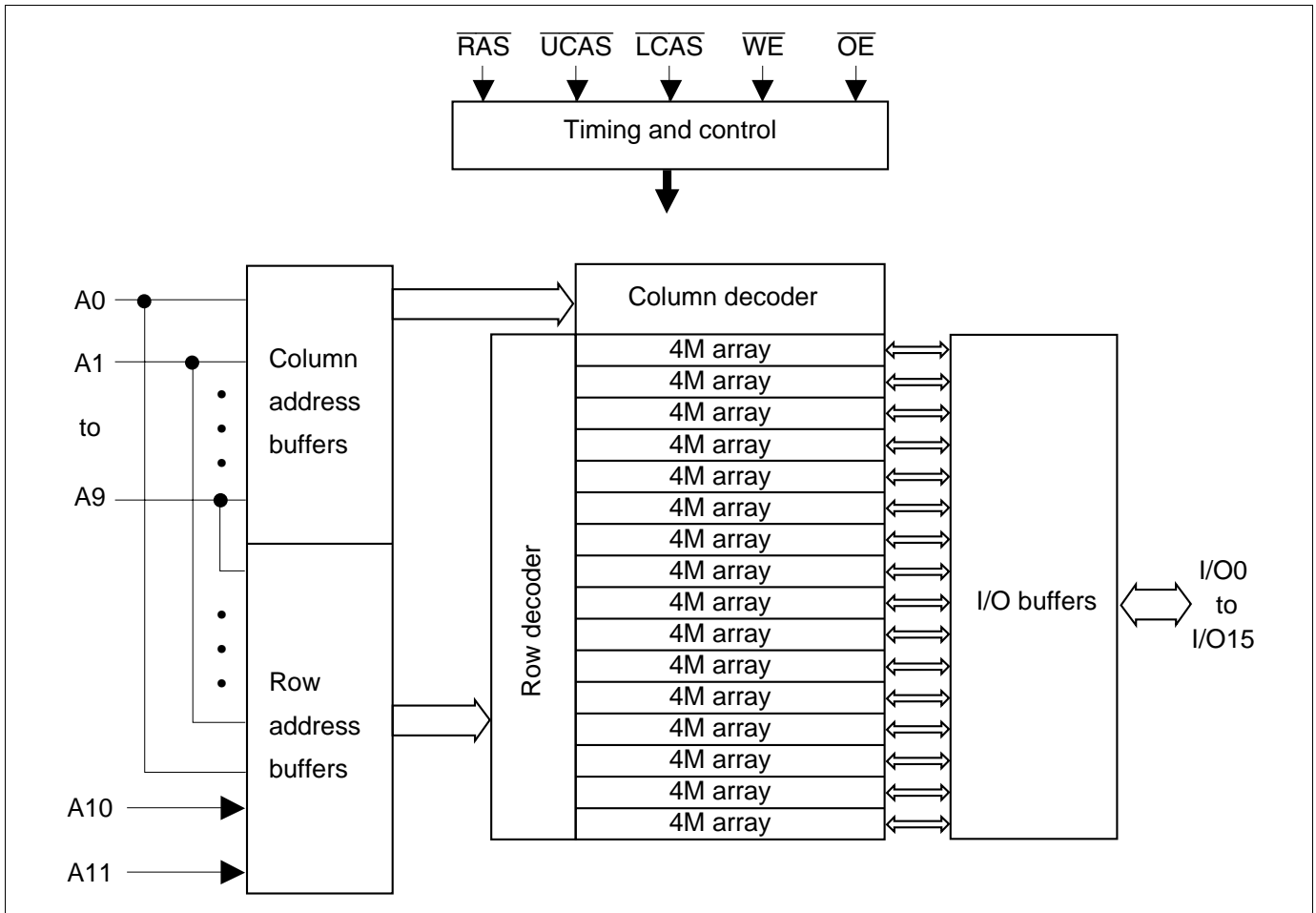

Operation Table

$\overline{\text{RAS}}$	$\overline{\text{LCAS}}$	$\overline{\text{UCAS}}$	$\overline{\text{WE}}$	$\overline{\text{OE}}$	I/O 0 to I/O 7	I/O 8 to I/O 15	Operation
H	×	×	×	×	High-Z	High-Z	Standby
L	L	H	H	L	Dout	High-Z	Read cycle
L	H	L	H	L	High-Z	Dout	
L	L	L	H	L	Dout	Dout	Early write cycle
L	L	H	L* ²	×	Din	×	
L	H	L	L* ²	×	×	Din	
L	L	L	L* ²	×	Din	Din	Delayed write cycle
L	L	H	L* ²	H	Din	×	
L	H	L	L* ²	H	×	Din	
L	L	L	L* ²	H	Din	Din	Read-modify-write cycle
L	L	H	H to L	L to H	Dout/Din	High-Z	
L	H	L	H to L	L to H	High-Z	Dout/Din	
L	L	L	H to L	L to H	Dout/Din	Dout/Din	$\overline{\text{RAS}}$ -only refresh cycle
L	H	H	×	×	High-Z	High-Z	
H to L	H	L	H	×	High-Z	High-Z	
H to L	L	H	H	×	High-Z	High-Z	$\overline{\text{CAS}}$ -before- $\overline{\text{RAS}}$ refresh cycle or Self refresh cycle (L-version)
H to L	L	L	H	×	High-Z	High-Z	Read cycle (Output disabled)
L	L	L	H	H	High-Z	High-Z	

Notes: 1. H: V_{IH} (inactive) L: V_{IL} (active) ×: V_{IH} or V_{IL}

2. $t_{wCS} \geq 0$ ns: Early write cycle

$t_{wCS} < 0$ ns: Delayed write cycle

3. Mode is determined by the OR function of the $\overline{\text{UCAS}}$ and $\overline{\text{LCAS}}$. (Mode is set by the earliest of $\overline{\text{UCAS}}$ and $\overline{\text{LCAS}}$ active edge and reset by the latest of $\overline{\text{UCAS}}$ and $\overline{\text{LCAS}}$ inactive edge.) However write operation and output High-Z control are done independently by each $\overline{\text{UCAS}}$, $\overline{\text{LCAS}}$.

ex. if $\overline{\text{RAS}} = \text{H to L}$, $\overline{\text{LCAS}} = \text{L}$, $\overline{\text{UCAS}} = \text{H}$, then $\overline{\text{CAS}}$ -before- $\overline{\text{RAS}}$ refresh cycle is selected.

HM5164165F Series, HM5165165F Series

Absolute Maximum Ratings

Parameter	Symbol	Value	Unit
Terminal voltage on any pin relative to V_{SS}	V_T	-0.5 to $V_{CC} + 0.5$ (≤ 4.6 V (max))	V
Power supply voltage relative to V_{SS}	V_{CC}	-0.5 to +4.6	V
Short circuit output current	I_{out}	50	mA
Power dissipation	P_T	1.0	W
Storage temperature	Tstg	-55 to +125	°C

DC Operating Conditions

Parameter	Symbol	Min	Typ	Max	Unit	Notes
Supply voltage	V_{CC}	3.0	3.3	3.6	V	1, 2
	V_{SS}	0	0	0	V	2
Input high voltage	V_{IH}	2.0	—	$V_{CC} + 0.3$	V	1
Input low voltage	V_{IL}	-0.3	—	0.8	V	1
Ambient temperature range	T_a	0	—	70	°C	

Notes: 1. All voltage referred to V_{SS} .

2. The supply voltage with all V_{CC} pins must be on the same level. The supply voltage with all V_{SS} pins must be on the same level.

DC Characteristics (HM5164165F Series)

Parameter	Symbol	HM5164165F				Unit	Test conditions
		-5		-6			
		Min	Max	Min	Max		
Operating current* ^{1, *2}	I_{CC1}	—	120	—	110	mA	$t_{RC} = \text{min}$
Standby current	I_{CC2}	—	2	—	2	mA	TTL interface $\overline{RAS}, \overline{UCAS}, \overline{LCAS} = V_{IH}$ Dout = High-Z
		—	0.5	—	0.5	mA	CMOS interface $\overline{RAS}, \overline{UCAS}, \overline{LCAS} \geq V_{CC} - 0.2 \text{ V}$ Dout = High-Z
Standby current (L-version)	I_{CC2}	—	300	—	300	μA	CMOS interface $\overline{RAS}, \overline{UCAS}, \overline{LCAS} \geq V_{CC} - 0.2 \text{ V}$ Dout = High-Z
\overline{RAS} -only refresh current* ²	I_{CC3}	—	120	—	110	mA	$t_{RC} = \text{min}$
Standby current* ¹	I_{CC5}	—	5	—	5	mA	$\overline{RAS} = V_{IH}$ $\overline{UCAS}, \overline{LCAS} = V_{IL}$ Dout = enable
\overline{CAS} -before- \overline{RAS} refresh current	I_{CC6}	—	120	—	110	mA	$t_{RC} = \text{min}$
EDO page mode current* ^{1, *3}	I_{CC7}	—	120	—	110	mA	$\overline{RAS} = V_{IL}, \overline{CAS}$ cycle, $t_{HPC} = t_{HPC} \text{ min}$
Battery backup current* ⁴ (Standby with CBR refresh) (L-version)	I_{CC10}	—	1.2	—	1.2	mA	CMOS interface Dout = High-Z CBR refresh: $t_{RC} = 15.6 \mu\text{s}$ $t_{RAS} \leq 0.3 \mu\text{s}$
Self refresh mode current (L-version)	I_{CC11}	—	500	—	500	μA	CMOS interface $\overline{RAS}, \overline{UCAS}, \overline{LCAS} \leq 0.2 \text{ V}$ Dout = High-Z
Input leakage current	I_{LI}	-5	5	-5	5	μA	$0 \text{ V} \leq V_{in} \leq V_{CC} + 0.3 \text{ V}$
Output leakage current	I_{LO}	-5	5	-5	5	μA	$0 \text{ V} \leq V_{out} \leq V_{CC}$ Dout = disable
Output high voltage	V_{OH}	2.4	V_{CC}	2.4	V_{CC}	V	High Iout = -2 mA
Output low voltage	V_{OL}	0	0.4	0	0.4	V	Low Iout = 2 mA

Notes: 1. I_{CC} depends on output load condition when the device is selected. I_{CC} max is specified at the output open condition.

2. Address can be changed once or less while $\overline{RAS} = V_{IL}$.

3. Measured with one sequential address change per EDO cycle, t_{HPC} .

4. $V_{IH} \geq V_{CC} - 0.2 \text{ V}, 0 \text{ V} \leq V_{IL} \leq 0.2 \text{ V}$.

HM5164165F Series, HM5165165F Series

DC Characteristics (HM5165165F Series)

Parameter	Symbol	HM5165165F				Unit	Test conditions
		-5		-6			
		Min	Max	Min	Max		
Operating current* ^{1, *2}	I_{CC1}	—	140	—	120	mA	$t_{RC} = \text{min}$
Standby current	I_{CC2}	—	2	—	2	mA	TTL interface $\overline{RAS}, \overline{UCAS}, \overline{LCAS} = V_{IH}$ Dout = High-Z
		—	0.5	—	0.5	mA	CMOS interface RAS, UCAS, $\overline{LCAS} \geq V_{CC} - 0.2 V$ Dout = High-Z
Standby current (L-version)	I_{CC2}	—	300	—	300	μA	CMOS interface RAS, UCAS, $\overline{LCAS} \geq V_{CC} - 0.2 V$ Dout = High-Z
\overline{RAS} -only refresh current* ²	I_{CC3}	—	140	—	120	mA	$t_{RC} = \text{min}$
Standby current* ¹	I_{CC5}	—	5	—	5	mA	$\overline{RAS} = V_{IH}$ $\overline{UCAS}, \overline{LCAS} = V_{IL}$ Dout = enable
\overline{CAS} -before- \overline{RAS} refresh current	I_{CC6}	—	140	—	120	mA	$t_{RC} = \text{min}$
EDO page mode current* ^{1, *3}	I_{CC7}	—	120	—	110	mA	$\overline{RAS} = V_{IL}$, \overline{CAS} cycle, $t_{HPC} = t_{HPC} \text{ min}$
Battery backup current* ⁴ (Standby with CBR refresh) (L-version)	I_{CC10}	—	1.2	—	1.2	mA	CMOS interface Dout = High-Z CBR refresh: $t_{RC} = 15.6 \mu s$ $t_{RAS} \leq 0.3 \mu s$
Self refresh mode current (L-version)	I_{CC11}	—	500	—	500	μA	CMOS interface RAS, UCAS, $\overline{LCAS} \leq 0.2 V$ Dout = High-Z
Input leakage current	I_{LI}	-5	5	-5	5	μA	$0 V \leq V_{in} \leq V_{CC} + 0.3 V$
Output leakage current	I_{LO}	-5	5	-5	5	μA	$0 V \leq V_{out} \leq V_{CC}$ Dout = disable
Output high voltage	V_{OH}	2.4	V_{CC}	2.4	V_{CC}	V	High Iout = -2 mA
Output low voltage	V_{OL}	0	0.4	0	0.4	V	Low Iout = 2 mA

Notes: 1. I_{CC} depends on output load condition when the device is selected. I_{CC} max is specified at the output open condition.

2. Address can be changed once or less while $\overline{RAS} = V_{IL}$.

3. Measured with one sequential address change per EDO cycle, t_{HPC} .

4. $V_{IH} \geq V_{CC} - 0.2 V$, $0 V \leq V_{IL} \leq 0.2 V$.

Capacitance ($T_a = 25^\circ\text{C}$, $V_{CC} = 3.3\text{ V} \pm 0.3\text{ V}$)

Parameter	Symbol	Min	Typ	Max	Unit	Notes
Input capacitance (Address)	C_{I1}	—	—	5	pF	1
Input capacitance (Clocks)	C_{I2}	—	—	7	pF	1
Output capacitance (Data-in, Data-out)	$C_{I/O}$	—	—	7	pF	1, 2

- Notes : 1. Capacitance measured with Boonton Meter or effective capacitance measuring method.
2. $\overline{\text{RAS}}$, $\overline{\text{UCAS}}$ and $\overline{\text{LCAS}} = V_{IH}$ to disable Dout.

HM5164165F Series, HM5165165F Series

AC Characteristics ($T_a = 0$ to $+70^\circ\text{C}$, $V_{CC} = 3.3\text{ V} \pm 0.3\text{ V}$, $V_{SS} = 0\text{ V}$)*¹, *², *¹⁹, *²⁶

Test Conditions

- Input rise and fall time: 2 ns
- Input pulse levels: $V_{IL} = 0\text{ V}$, $V_{IH} = 3.0\text{ V}$
- Input timing reference levels: 0.8 V, 2.0 V
- Output timing reference levels: 0.8 V, 2.0 V
- Output load: 1 TTL gate + C_L (100 pF) (Including scope and jig)

Read, Write, Read-Modify-Write and Refresh Cycles (Common parameters)

Parameter	Symbol	HM5164165F/HM5165165F				Unit	Notes
		-5		-6			
		Min	Max	Min	Max		
Random read or write cycle time	t_{RC}	84	—	104	—	ns	
$\overline{\text{RAS}}$ precharge time	t_{RP}	30	—	40	—	ns	
$\overline{\text{CAS}}$ precharge time	t_{CP}	8	—	10	—	ns	30
$\overline{\text{RAS}}$ pulse width	t_{RAS}	50	10000	60	10000	ns	
$\overline{\text{CAS}}$ pulse width	t_{CAS}	8	10000	10	10000	ns	
Row address setup time	t_{ASR}	0	—	0	—	ns	
Row address hold time	t_{RAH}	8	—	10	—	ns	
Column address setup time	t_{ASC}	0	—	0	—	ns	27
Column address hold time	t_{CAH}	8	—	10	—	ns	27
$\overline{\text{RAS}}$ to $\overline{\text{CAS}}$ delay time	t_{RCD}	12	37	14	45	ns	3
$\overline{\text{RAS}}$ to column address delay time	t_{RAD}	10	25	12	30	ns	4
$\overline{\text{RAS}}$ hold time	t_{RSH}	13	—	15	—	ns	
$\overline{\text{CAS}}$ hold time	t_{CSH}	35	—	40	—	ns	
$\overline{\text{CAS}}$ to $\overline{\text{RAS}}$ precharge time	t_{CRP}	5	—	5	—	ns	28
$\overline{\text{OE}}$ to Din delay time	t_{OED}	13	—	15	—	ns	5
$\overline{\text{OE}}$ delay time from Din	t_{DZO}	0	—	0	—	ns	6
$\overline{\text{CAS}}$ delay time from Din	t_{DZC}	0	—	0	—	ns	6
Transition time (rise and fall)	t_T	2	50	2	50	ns	7

Read Cycle

Parameter	Symbol	HM5164165F/HM5165165F				Unit	Notes
		-5		-6			
		Min	Max	Min	Max		
Access time from $\overline{\text{RAS}}$	t_{RAC}	—	50	—	60	ns	8, 9
Access time from $\overline{\text{CAS}}$	t_{CAC}	—	13	—	15	ns	9, 10, 17
Access time from address	t_{AA}	—	25	—	30	ns	9, 11, 17
Access time from $\overline{\text{OE}}$	t_{OEA}	—	13	—	15	ns	9
Read command setup time	t_{RCS}	0	—	0	—	ns	27
Read command hold time to $\overline{\text{CAS}}$	t_{RCH}	0	—	0	—	ns	12, 28
Read command hold time from $\overline{\text{RAS}}$	t_{RCHR}	50	—	60	—	ns	
Read command hold time to $\overline{\text{RAS}}$	t_{RRH}	0	—	0	—	ns	12
Column address to $\overline{\text{RAS}}$ lead time	t_{RAL}	25	—	30	—	ns	
Column address to $\overline{\text{CAS}}$ lead time	t_{CAL}	15	—	18	—	ns	
$\overline{\text{CAS}}$ to output in low-Z	t_{CLZ}	0	—	0	—	ns	
Output data hold time	t_{OH}	3	—	3	—	ns	21
Output data hold time from $\overline{\text{OE}}$	t_{OHO}	3	—	3	—	ns	
Output buffer turn-off time	t_{OFF}	—	13	—	15	ns	13, 21
Output buffer turn-off to $\overline{\text{OE}}$	t_{OEZ}	—	13	—	15	ns	13
$\overline{\text{CAS}}$ to Din delay time	t_{CDD}	13	—	15	—	ns	5
Output data hold time from $\overline{\text{RAS}}$	t_{OHR}	3	—	3	—	ns	21
Output buffer turn-off to $\overline{\text{RAS}}$	t_{OFR}	—	13	—	15	ns	13, 21
Output buffer turn-off to $\overline{\text{WE}}$	t_{WEZ}	—	13	—	15	ns	13
$\overline{\text{WE}}$ to Din delay time	t_{WED}	13	—	15	—	ns	
$\overline{\text{RAS}}$ to Din delay time	t_{RDD}	13	—	15	—	ns	

HM5164165F Series, HM5165165F Series

Write Cycle

Parameter	Symbol	HM5164165F/HM5165165F				Unit	Notes
		-5		-6			
		Min	Max	Min	Max		
Write command setup time	t_{WCS}	0	—	0	—	ns	14, 27
Write command hold time	t_{WCH}	8	—	10	—	ns	27
Write command pulse width	t_{WP}	8	—	10	—	ns	
Write command to \overline{RAS} lead time	t_{RWL}	13	—	15	—	ns	
Write command to \overline{CAS} lead time	t_{CWL}	8	—	10	—	ns	29
Data-in setup time	t_{DS}	0	—	0	—	ns	15, 29
Data-in hold time	t_{DH}	8	—	10	—	ns	15, 29

Read-Modify-Write Cycle

Parameter	Symbol	HM5164165F/HM5165165F				Unit	Notes
		-5		-6			
		Min	Max	Min	Max		
Read-modify-write cycle time	t_{RWC}	116	—	140	—	ns	
\overline{RAS} to \overline{WE} delay time	t_{RWD}	67	—	79	—	ns	14
\overline{CAS} to \overline{WE} delay time	t_{CWD}	30	—	34	—	ns	14
Column address to \overline{WE} delay time	t_{AWD}	42	—	49	—	ns	14
\overline{OE} hold time from \overline{WE}	t_{OEH}	13	—	15	—	ns	

Refresh Cycle

Parameter	Symbol	HM5164165F/HM5165165F				Unit	Notes
		-5		-6			
		Min	Max	Min	Max		
\overline{CAS} setup time (CBR refresh cycle)	t_{CSR}	5	—	5	—	ns	27
\overline{CAS} hold time (CBR refresh cycle)	t_{CHR}	8	—	10	—	ns	28
\overline{WE} setup time (CBR refresh cycle)	t_{WRP}	0	—	0	—	ns	
\overline{WE} hold time (CBR refresh cycle)	t_{WRH}	8	—	10	—	ns	
\overline{RAS} precharge to \overline{CAS} hold time	t_{RPC}	5	—	5	—	ns	27

EDO Page Mode Cycle

Parameter	Symbol	HM5164165F/HM5165165F				Unit	Notes
		-5		-6			
		Min	Max	Min	Max		
EDO page mode cycle time	t_{HPC}	20	—	25	—	ns	20
EDO page mode \overline{RAS} pulse width	t_{RASP}	—	100000	—	100000	ns	16
Access time from \overline{CAS} precharge	t_{CPA}	—	28	—	35	ns	9, 17, 28
\overline{RAS} hold time from \overline{CAS} precharge	t_{CPRH}	28	—	35	—	ns	
Output data hold time from \overline{CAS} low	t_{DOH}	3	—	3	—	ns	9, 22
\overline{CAS} hold time referred \overline{OE}	t_{COL}	8	—	10	—	ns	
\overline{CAS} to \overline{OE} setup time	t_{COP}	5	—	5	—	ns	
Read command hold time from \overline{CAS} precharge	t_{RCHC}	28	—	35	—	ns	
Write pulse width during \overline{CAS} precharge	t_{WPE}	8	—	10	—	ns	
\overline{OE} precharge time	t_{OEP}	8	—	10	—	ns	

EDO Page Mode Read-Modify-Write Cycle

Parameter	Symbol	HM5164165F/HM5165165F				Unit	Notes
		-5		-6			
		Min	Max	Min	Max		
EDO page mode read-modify-write cycle time	t_{HPRWC}	57	—	68	—	ns	
\overline{WE} delay time from \overline{CAS} precharge	t_{CPW}	45	—	54	—	ns	14, 28

Refresh (HM5164165F Series)

Parameter	Symbol	Max	Unit	Note
Refresh period	t_{REF}	64	ms	8192 cycles

HM5164165F Series, HM5165165F Series

Refresh (HM5165165F Series)

Parameter	Symbol	Max	Unit	Note
Refresh period	t_{REF}	64	ms	4096 cycles

Self Refresh Mode (L-version)

Parameter	Symbol	HM5164165FL/HM5165165FL				Unit	Notes
		-5		-6			
		Min	Max	Min	Max		
\overline{RAS} pulse width (self refresh)	t_{RASS}	100	—	100	—	μs	25
\overline{RAS} precharge time (self refresh)	t_{RPS}	90	—	110	—	ns	25
\overline{CAS} hold time (self refresh)	t_{CHS}	-50	—	-50	—	ns	29

Notes: 1. AC measurements assume $t_T = 2$ ns.

- An initial pause of 200 μs is required after power up followed by a minimum of eight initialization cycles (any combination of cycles containing \overline{RAS} -only refresh or \overline{CAS} -before- \overline{RAS} refresh).
- Operation with the t_{RCD} (max) limit insures that t_{RAC} (max) can be met, t_{RCD} (max) is specified as a reference point only; if t_{RCD} is greater than the specified t_{RCD} (max) limit, then the access time is controlled exclusively by t_{CAC} .
- Operation with the t_{RAD} (max) limit insures that t_{RAC} (max) can be met, t_{RAD} (max) is specified as a reference point only; if t_{RAD} is greater than the specified t_{RAD} (max) limit, then access time is controlled exclusively by t_{AA} .
- Either t_{OED} or t_{CDD} must be satisfied.
- Either t_{DZO} or t_{DZC} must be satisfied.
- V_{IH} (min) and V_{IL} (max) are reference levels for measuring timing of input signals. Also, transition times are measured between V_{IH} (min) and V_{IL} (max).
- Assumes that $t_{RCD} \leq t_{RCD}$ (max) and $t_{RAD} \leq t_{RAD}$ (max). If t_{RCD} or t_{RAD} is greater than the maximum recommended value shown in this table, t_{RAC} exceeds the value shown.
- Measured with a load circuit equivalent to 1 TTL loads and 100 pF.
- Assumes that $t_{RCD} \geq t_{RCD}$ (max) and $t_{RCD} + t_{CAC}$ (max) $\geq t_{RAD} + t_{AA}$ (max).
- Assumes that $t_{RAD} \geq t_{RAD}$ (max) and $t_{RCD} + t_{CAC}$ (max) $\leq t_{RAD} + t_{AA}$ (max).
- Either t_{RCH} or t_{RRH} must be satisfied for a read cycles.
- t_{OFF} (max), t_{OEZ} (max), t_{WEZ} (max) and t_{OFR} (max) define the time at which the outputs achieve the open circuit condition and are not referred to output voltage levels.
- t_{WCS} , t_{RWD} , t_{CWD} , t_{AWD} and t_{CPW} are not restrictive operating parameters. They are included in the data sheet as electrical characteristics only; if $t_{WCS} \geq t_{WCS}$ (min), the cycle is an early write cycle and the data out pin will remain open circuit (high impedance) throughout the entire cycle; if $t_{RWD} \geq t_{RWD}$ (min), $t_{CWD} \geq t_{CWD}$ (min), and $t_{AWD} \geq t_{AWD}$ (min), or $t_{CWD} \geq t_{CWD}$ (min), $t_{AWD} \geq t_{AWD}$ (min) and $t_{CPW} \geq t_{CPW}$ (min), the cycle is a read-modify-write and the data output will contain data read from the selected cell; if neither of the above sets of conditions is satisfied, the condition of the data out (at access time) is indeterminate.
- t_{DS} and t_{DH} are referred to \overline{UCAS} and \overline{LCAS} leading edge in early write cycles and to \overline{WE} leading edge in delayed write or read-modify-write cycles.

16. t_{RASP} defines \overline{RAS} pulse width in EDO page mode cycles.
17. Access time is determined by the longest among t_{AA} , t_{CAC} and t_{CPA} .
18. In delayed write or read-modify-write cycles, \overline{OE} must disable output buffer prior to applying data to the device.
19. When output buffers are enabled once, sustain the low impedance state until valid data is obtained. When output buffer is turned on and off within a very short time, generally it causes large V_{CC}/V_{SS} line noise, which causes to degrade $V_{IH\ min}/V_{IL\ max}$ level.
20. t_{HPC} (min) can be achieved during a series of EDO page mode write cycles or EDO page mode read cycles. If both write and read operation are mixed in a EDO page mode \overline{RAS} cycle (EDO page mode mix cycle (1), (2)), minimum value of CAS cycle ($t_{CAS} + t_{CP} + 2 t_T$) becomes greater than the specified t_{HPC} (min) value. The value of \overline{CAS} cycle time of mixed EDO page mode is shown in EDO page mode mix cycle (1) and (2).
21. Data output turns off and becomes high impedance from later rising edge of \overline{RAS} and \overline{CAS} . Hold time and turn off time are specified by the timing specifications of later rising edge of \overline{RAS} and \overline{CAS} between t_{OHR} and t_{OH} , and between t_{OFR} and t_{OFF} .
22. t_{DOH} defines the time at which the output level go cross. $V_{OL} = 0.8\ V$, $V_{OH} = 2.0\ V$ of output timing reference level.
23. Before and after self refresh mode, execute CBR refresh to all refresh addresses in or within 64 ms period on the condition a and b below.
 - a. Enter self refresh mode within 15.6 μs after either burst refresh or distributed refresh at equal interval to all refresh addresses are completed.
 - b. Start burst refresh or distributed refresh at equal interval to all refresh addresses within 15.6 μs after exiting from self refresh mode.
24. In case of entering from \overline{RAS} -only-refresh, it is necessary to execute CBR refresh before and after self refresh mode according as note 23.
25. At $t_{RASS} > 100\ \mu s$, self refresh mode is activated, and not activated at $t_{RASS} < 10\ \mu s$. It is undefined within the range of $10\ \mu s \leq t_{RASS} \leq 100\ \mu s$. For $t_{RASS} \geq 10\ \mu s$, it is necessary to satisfy t_{RPS} .
26. When both \overline{UCAS} and \overline{LCAS} go low at the same time, all 16-bit data are written into the device. \overline{UCAS} and \overline{LCAS} cannot be staggered within the same write/read cycles.
27. t_{ASC} , t_{CAH} , t_{RCS} , t_{WCS} , t_{WCH} , t_{CSR} and t_{RPC} are determined by the earlier falling edge of \overline{UCAS} or \overline{LCAS} .
28. t_{CRP} , t_{CHR} , t_{RCH} , t_{CPA} and t_{CPW} are determined by the later rising edge of \overline{UCAS} or \overline{LCAS} .
29. t_{CWL} , t_{DH} , t_{DS} and t_{CHS} should be satisfied by both \overline{UCAS} and \overline{LCAS} .
30. t_{CP} is determined by the time that both \overline{UCAS} and \overline{LCAS} are high.
31. XXX: H or L (H: $V_{IH\ (min)} \leq V_{IN} \leq V_{IH\ (max)}$, L: $V_{IL\ (min)} \leq V_{IN} \leq V_{IL\ (max)}$)
 /////////////// Invalid Dout
 When the address, clock and input pins are not described on timing waveforms, their pins must be applied V_{IH} or V_{IL} .

Notes concerning $\overline{2CAS}$ control

Please do not separate the $\overline{UCAS}/\overline{LCAS}$ operation timing intentionally. However skew between $\overline{UCAS}/\overline{LCAS}$ are allowed under the following conditions.

1. Each of the $\overline{UCAS}/\overline{LCAS}$ should satisfy the timing specifications individually.
2. Different operation mode for upper/lower byte is not allowed; such as following.

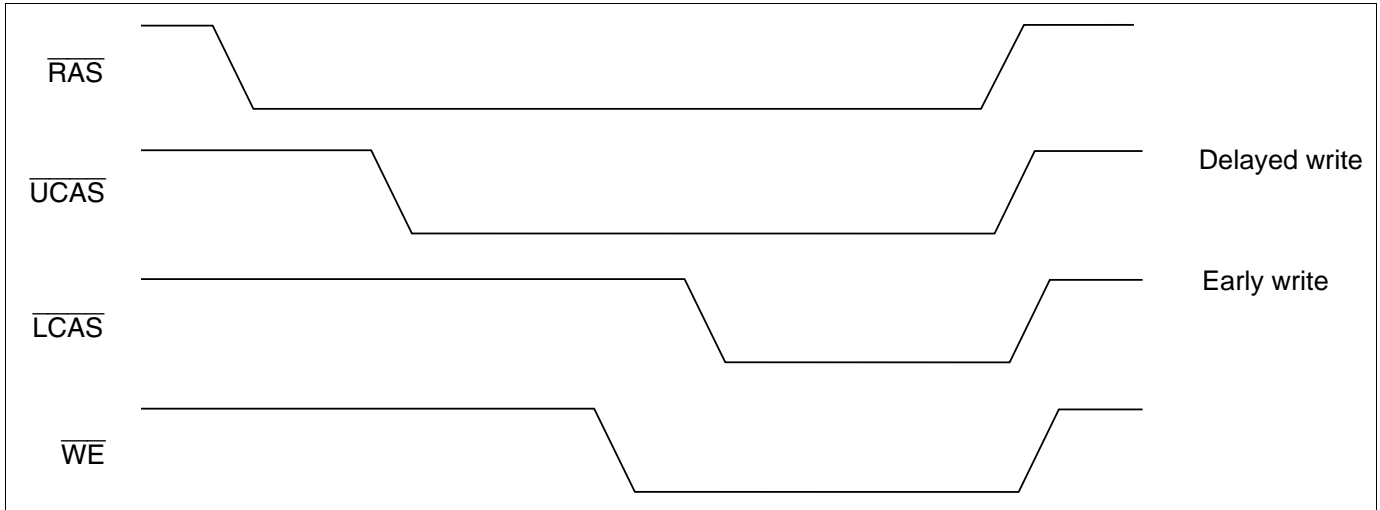

3. Closely separated upper/lower byte control is not allowed. However when the condition ($t_{CP} \leq t_{UL}$) is satisfied, EDO page mode can be performed.

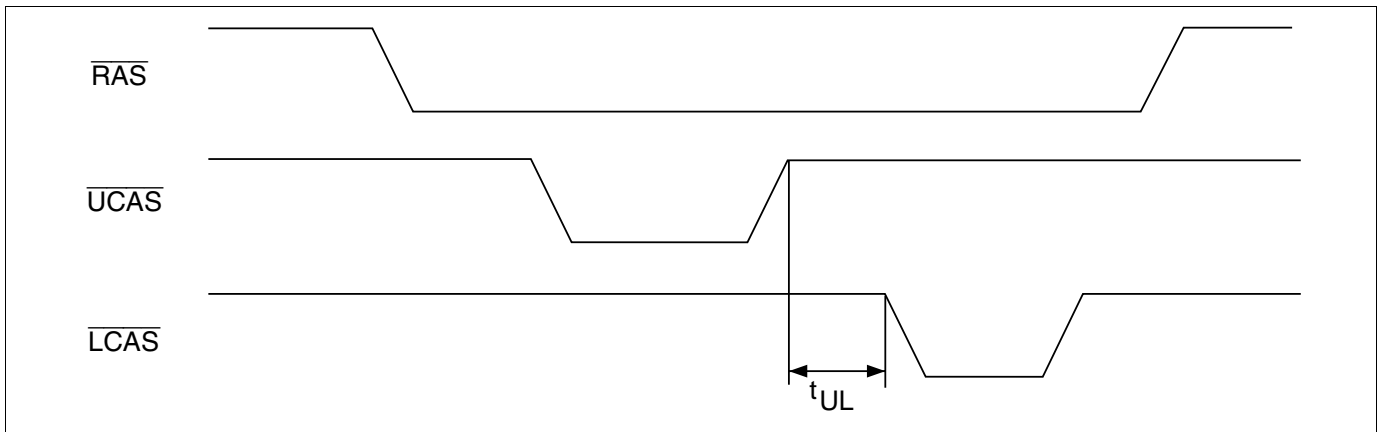

4. Byte control operation by remaining \overline{UCAS} or \overline{LCAS} high is guaranteed.

Timing Waveforms*31

Read Cycle

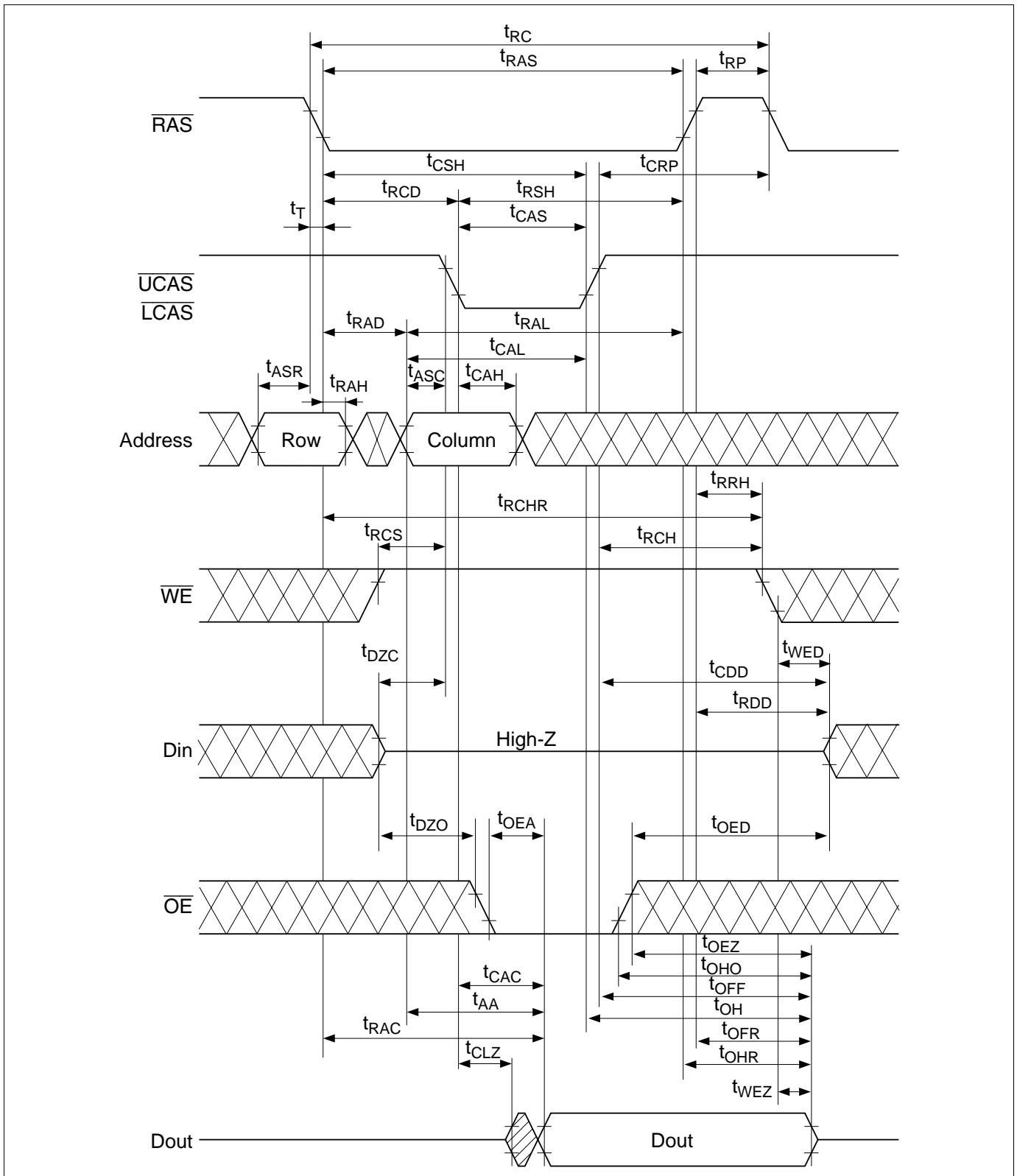

Early Write Cycle

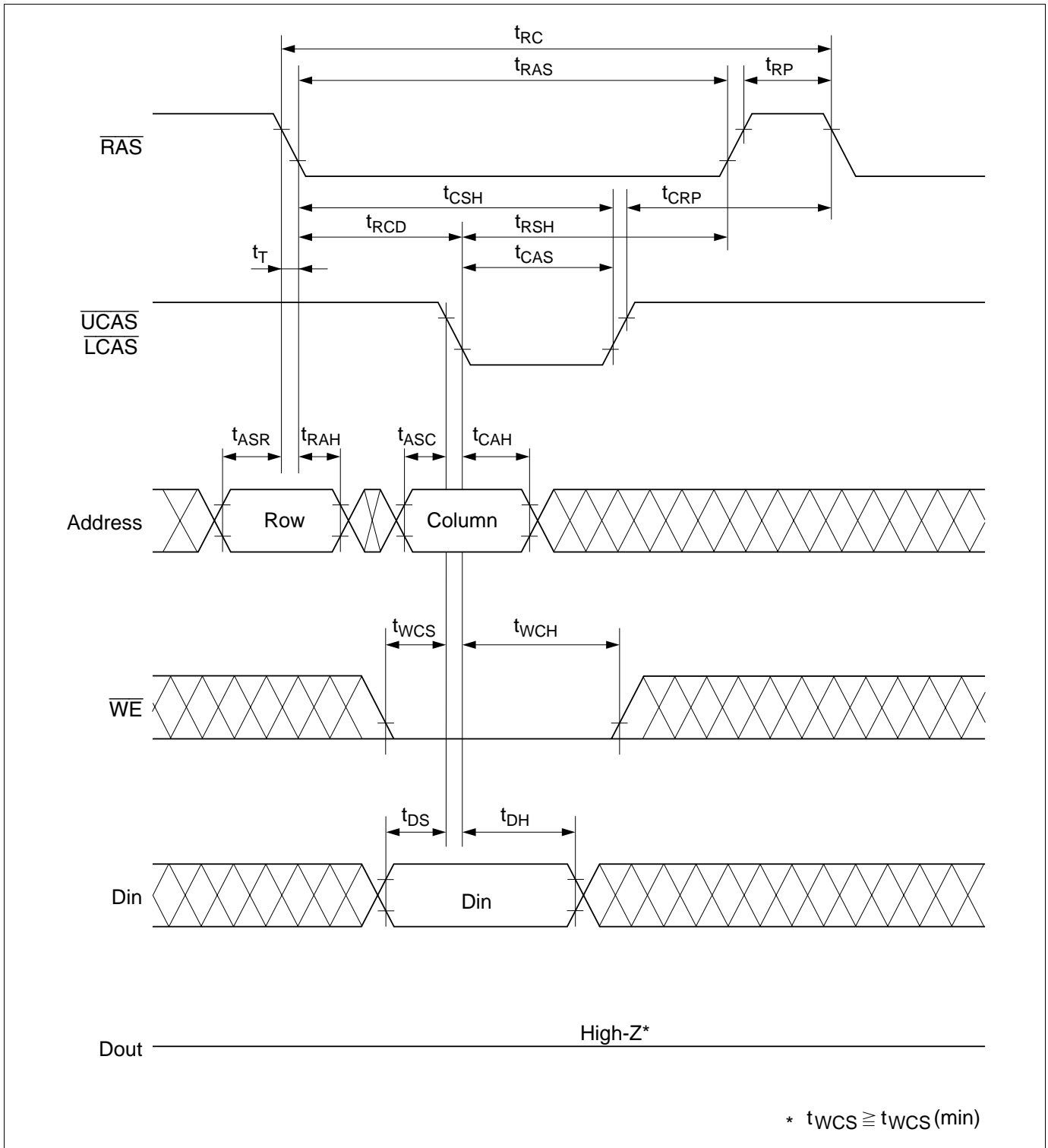

Delayed Write Cycle*18

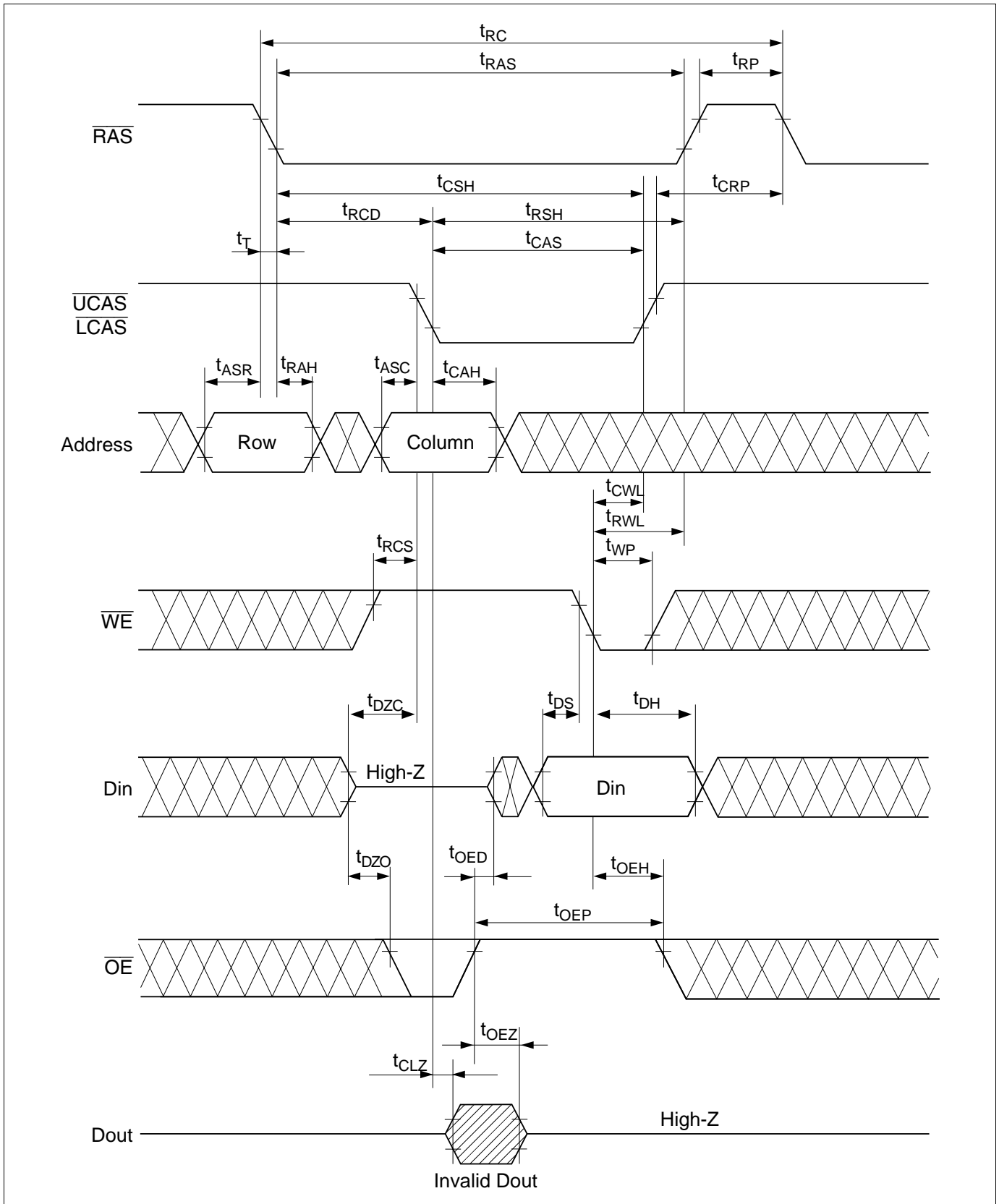

HM5164165F Series, HM5165165F Series

Read-Modify-Write Cycle*18

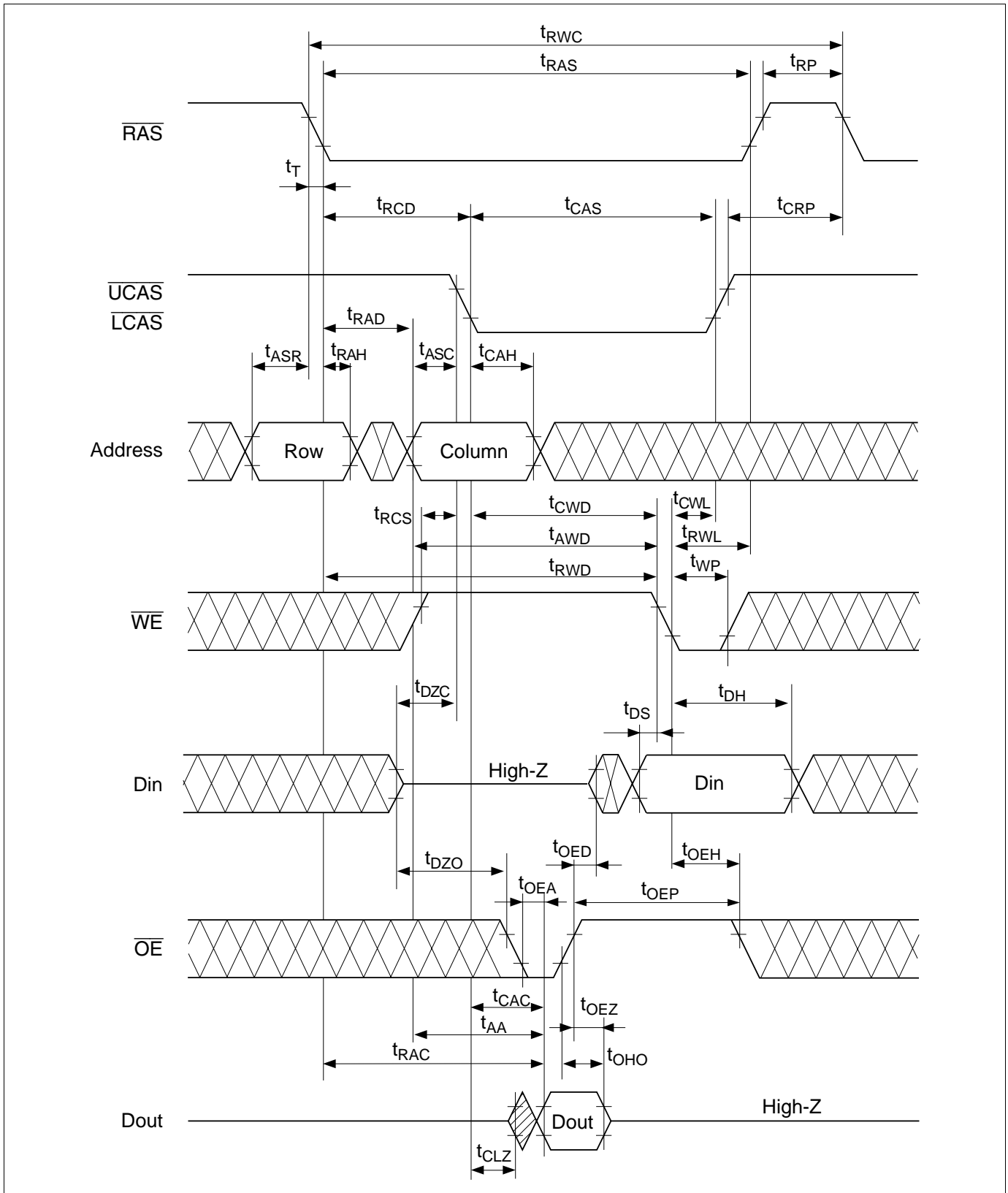

$\overline{\text{RAS}}$ -Only Refresh Cycle

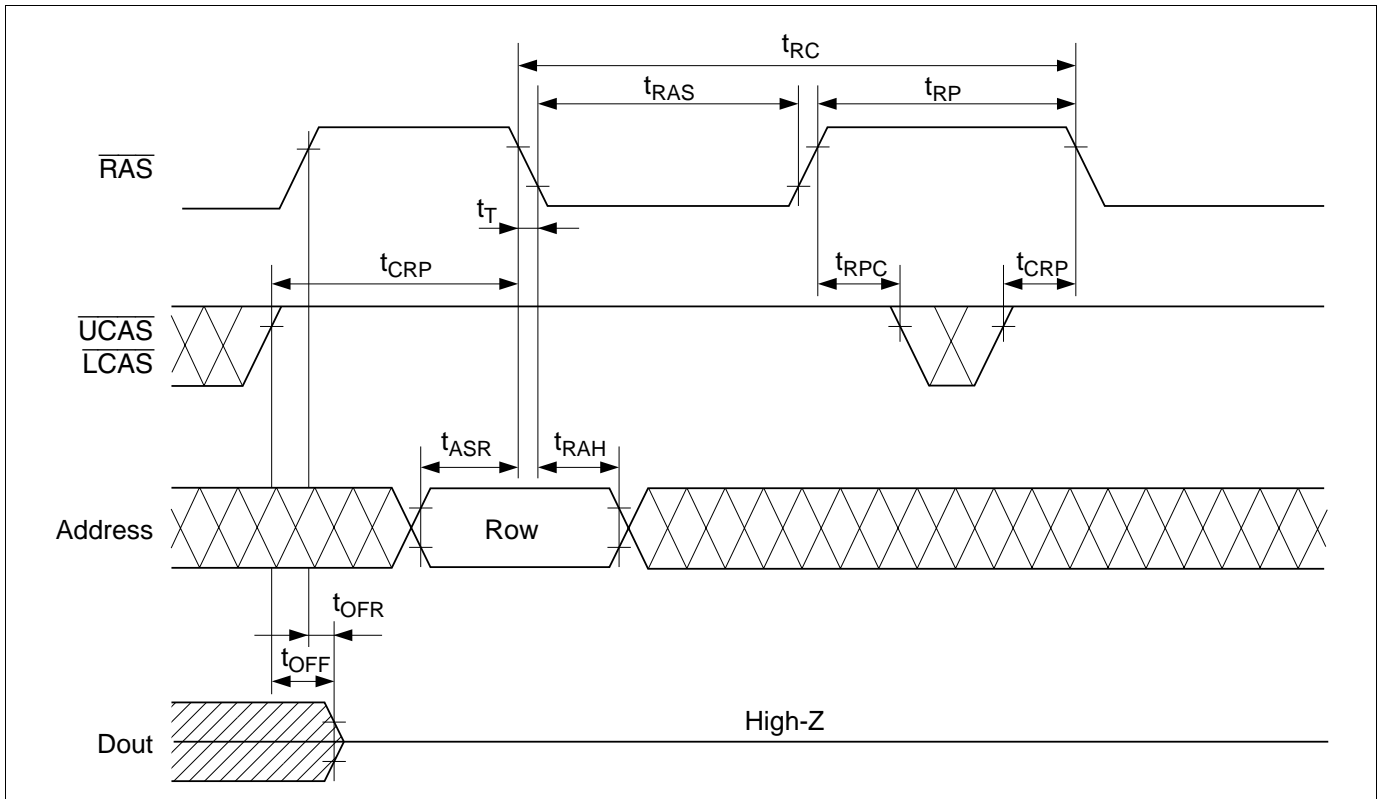

HM5164165F Series, HM5165165F Series

CAS-Before-RAS Refresh Cycle

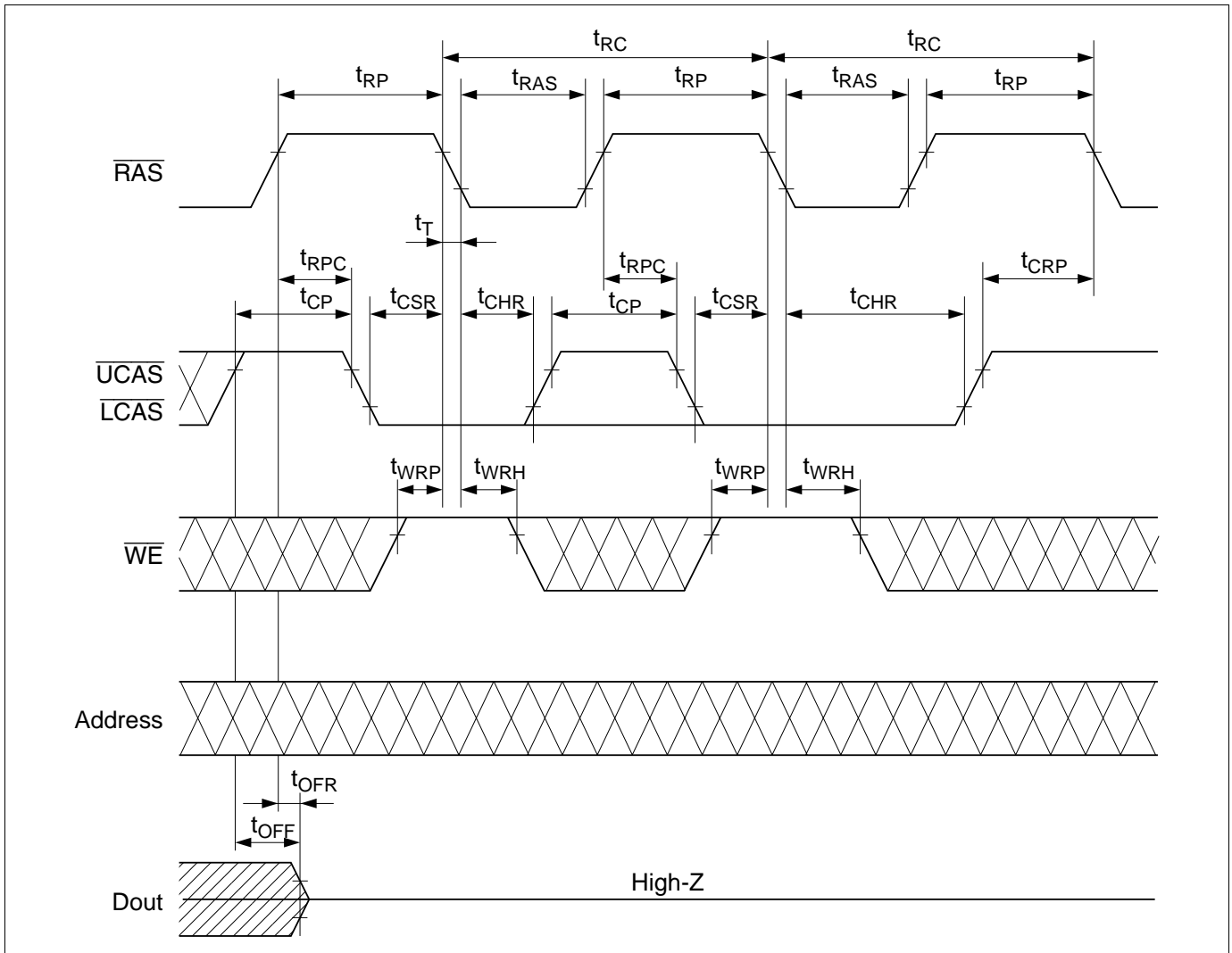

Hidden Refresh Cycle

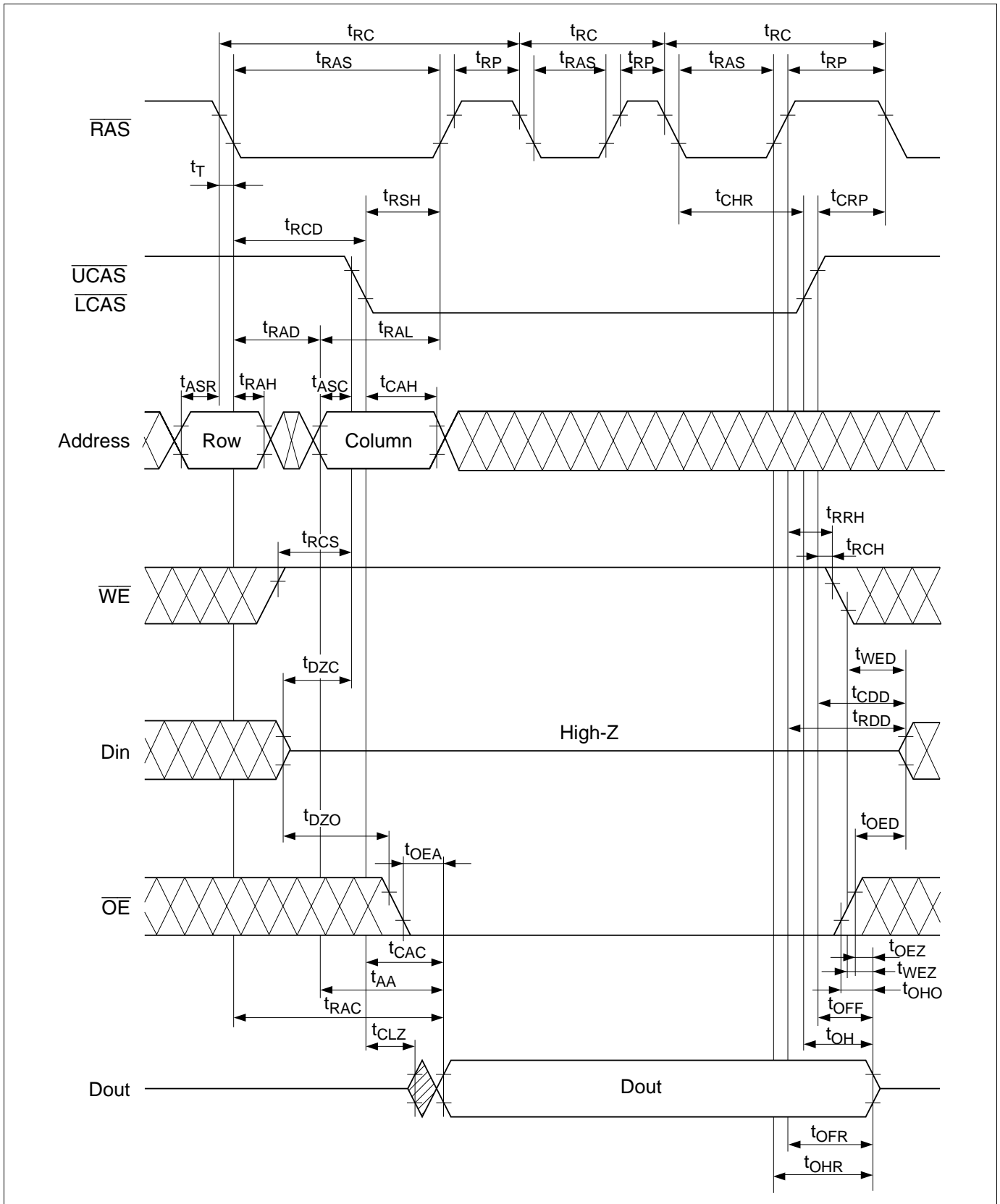

HM5164165F Series, HM5165165F Series

EDO Page Mode Read Cycle

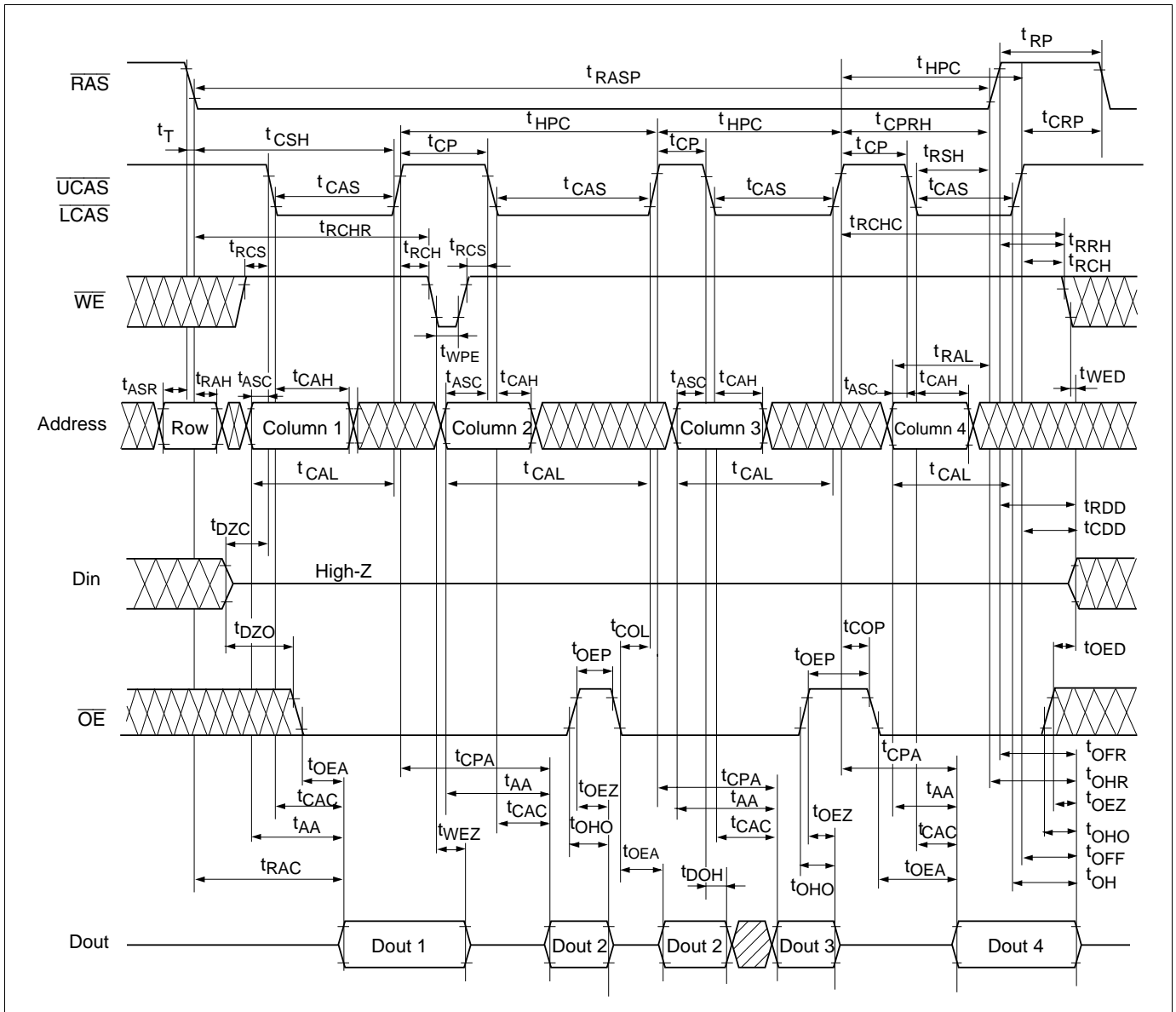

EDO Page Mode Early Write Cycle

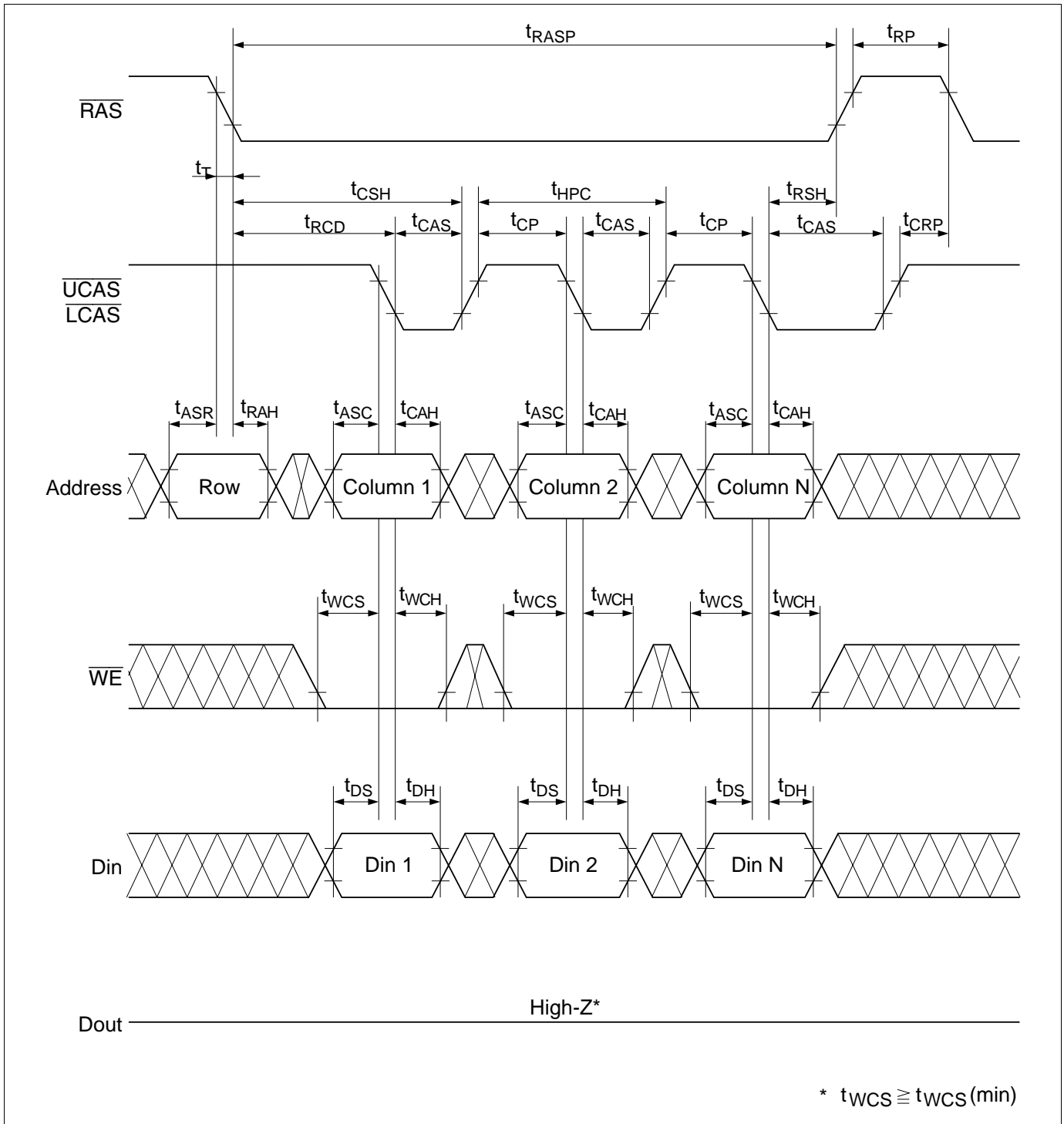

EDO Page Mode Delayed Write Cycle*18

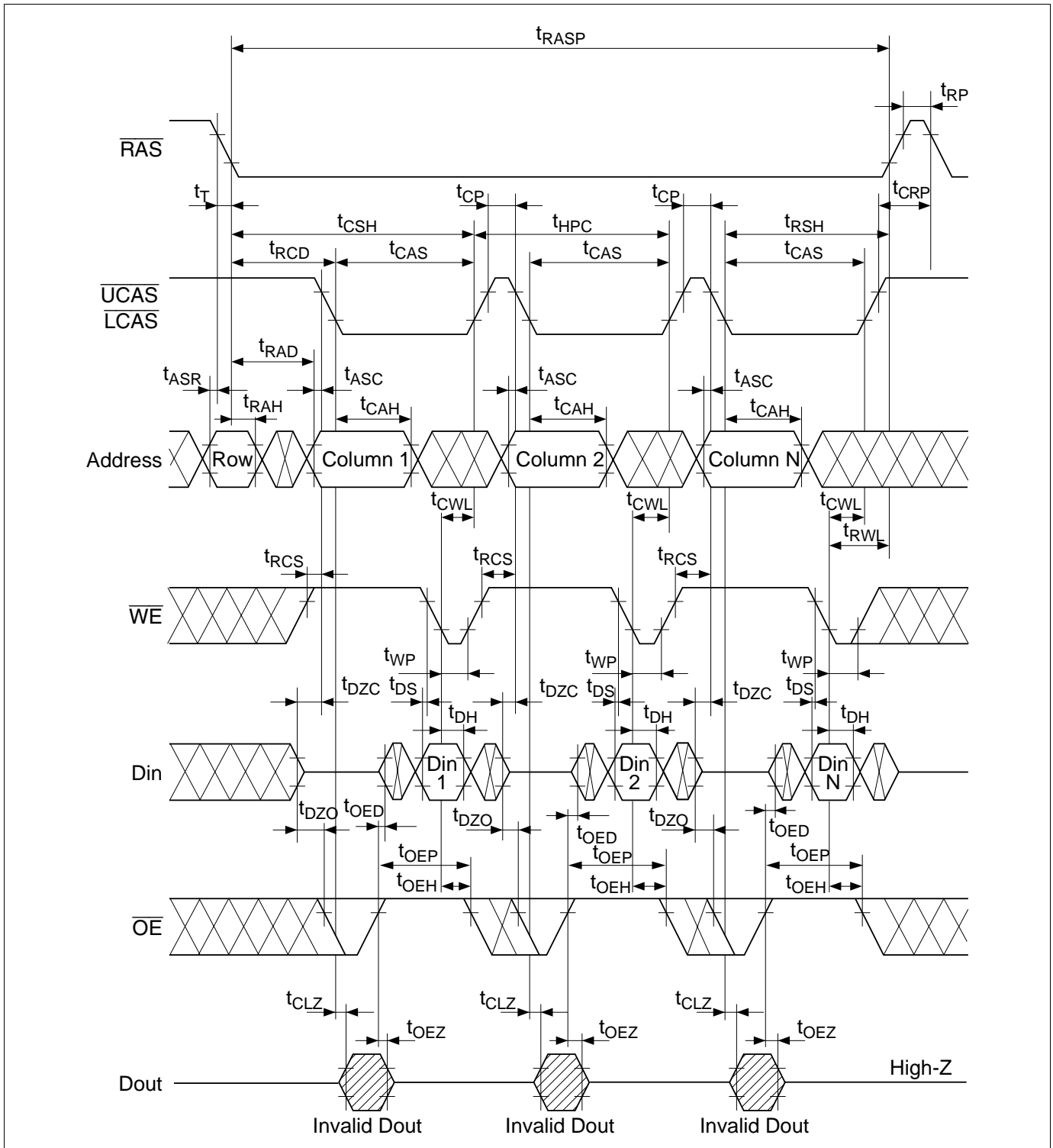

HM5164165F Series, HM5165165F Series

EDO Page Mode Read-Modify-Write Cycle*18

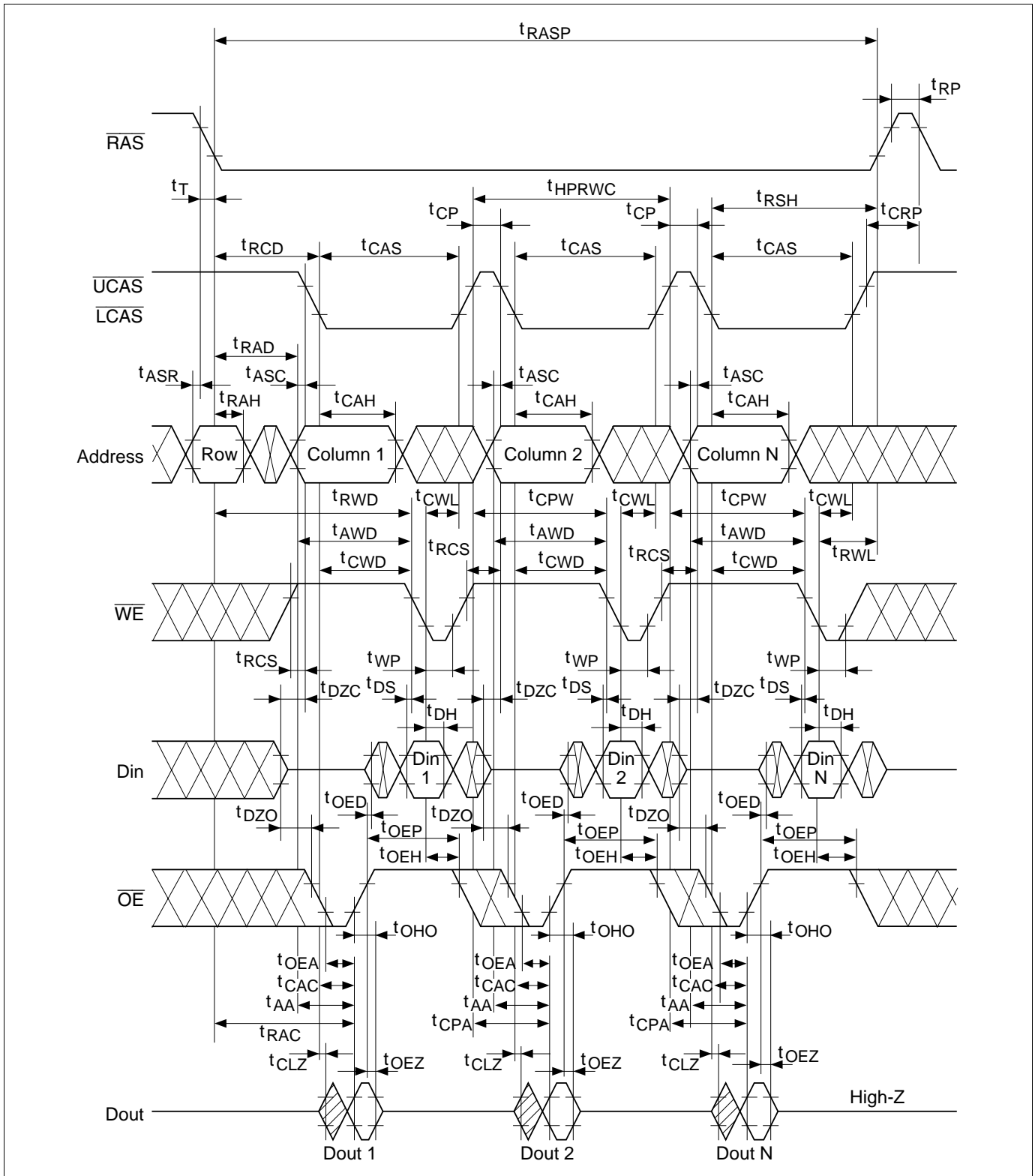

EDO Page Mode Mix Cycle (1) *20

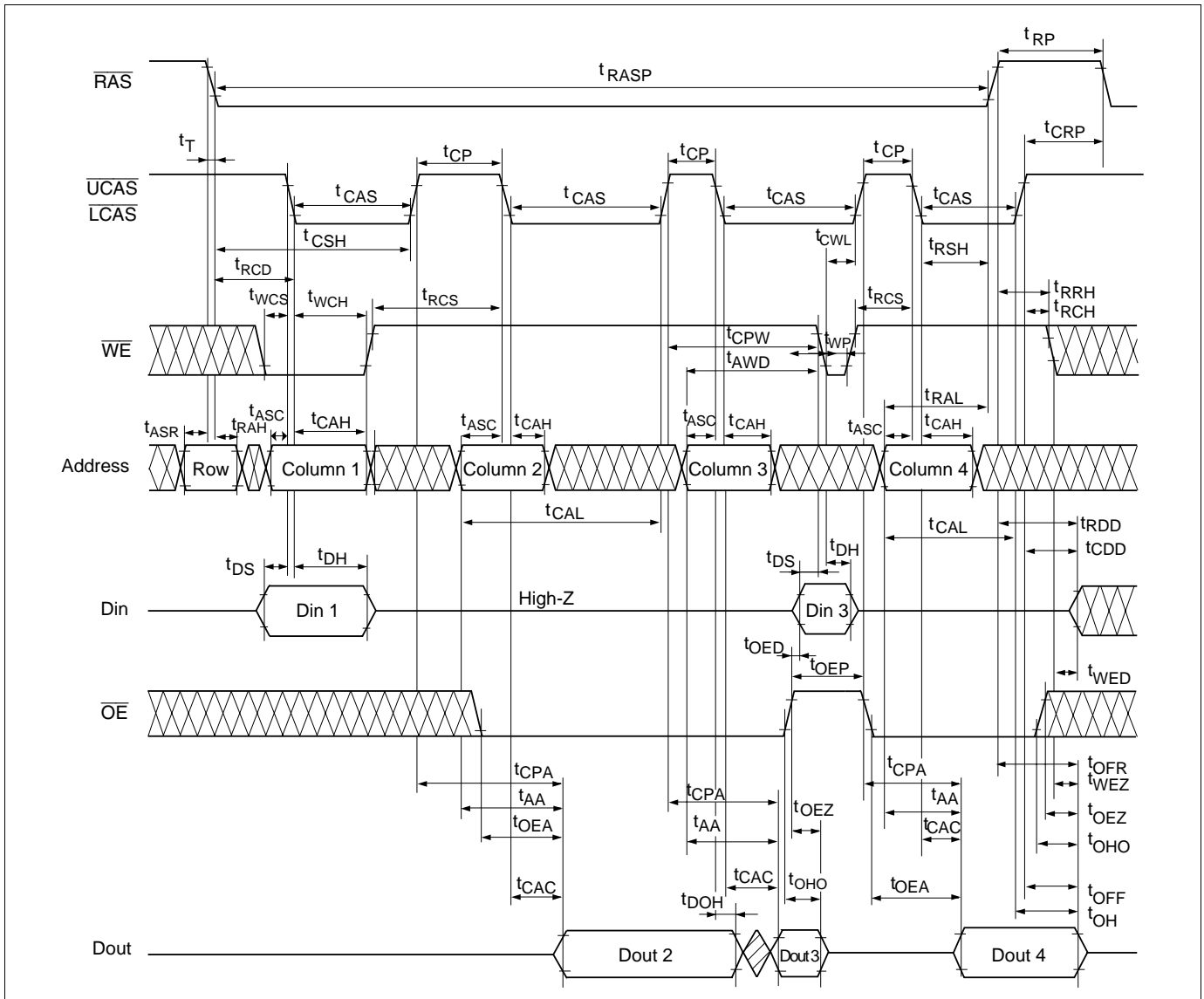

HM5164165F Series, HM5165165F Series

EDO Page Mode Mix Cycle (2)*20

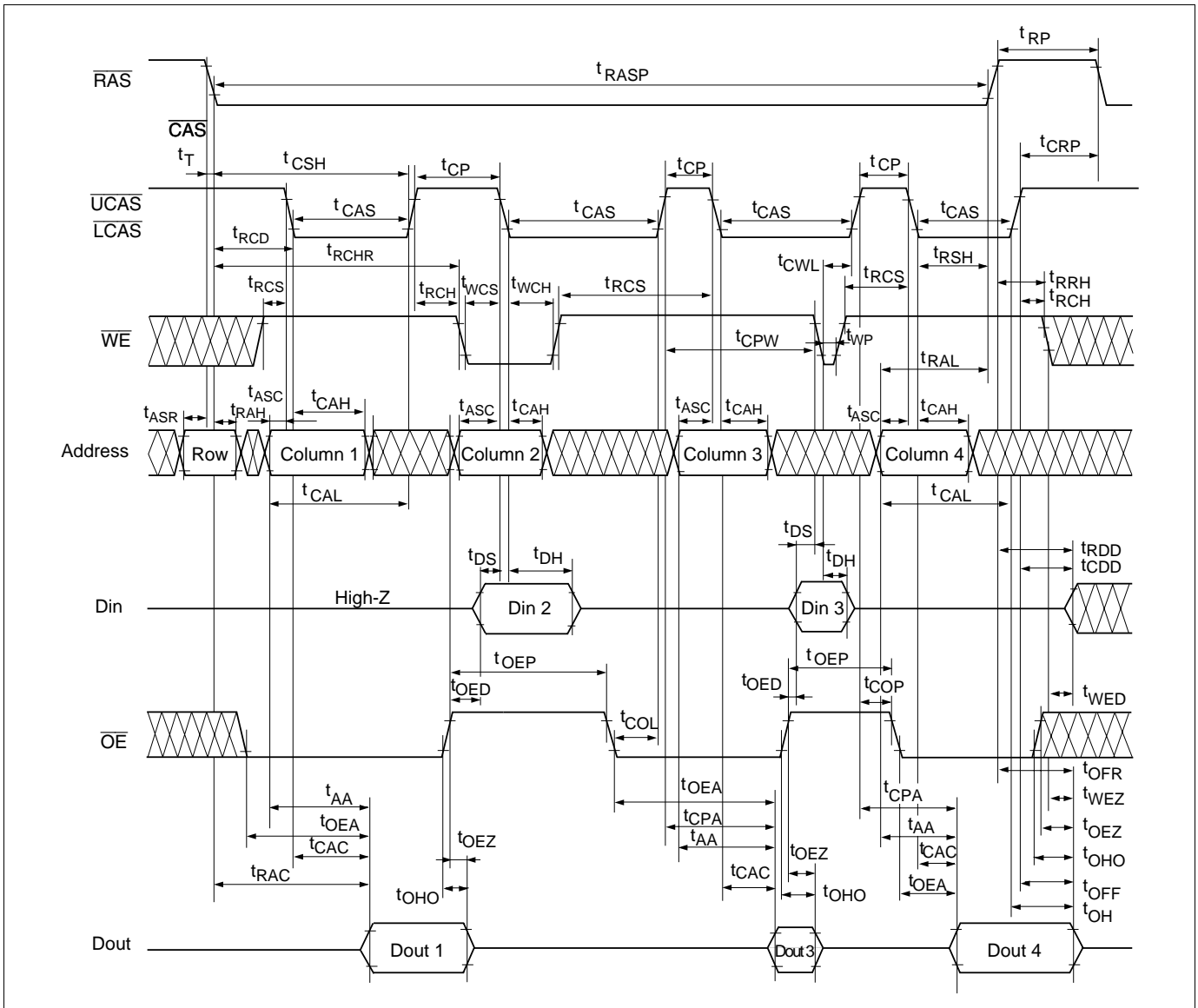

Self Refresh Cycle (L-version)*^{23, 24, 25}

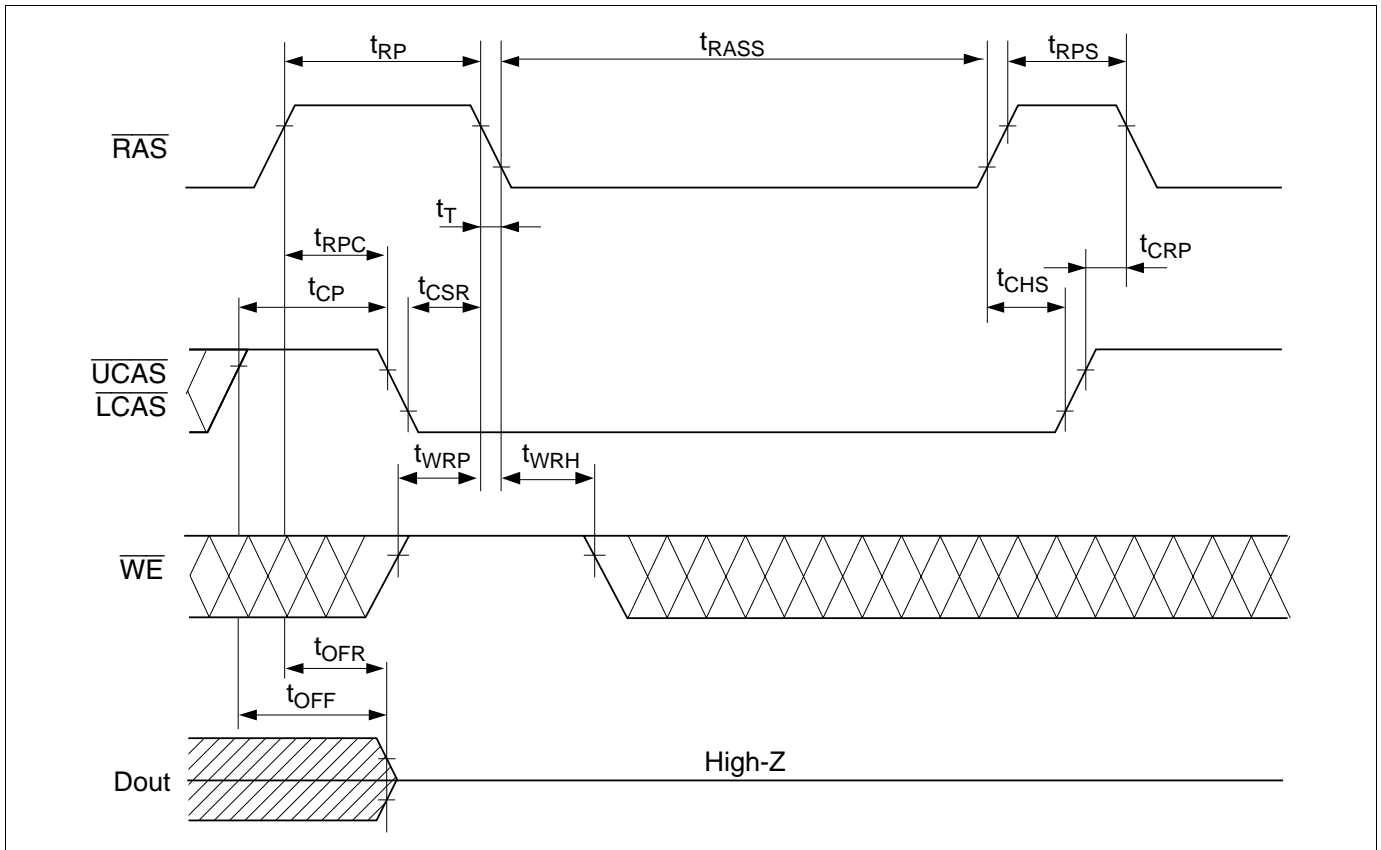

HM5164165F Series, HM5165165F Series

Package Dimensions

HM5164165FJ/FLJ Series

HM5165165FJ/FLJ Series (CP-50DA)

Unit: mm

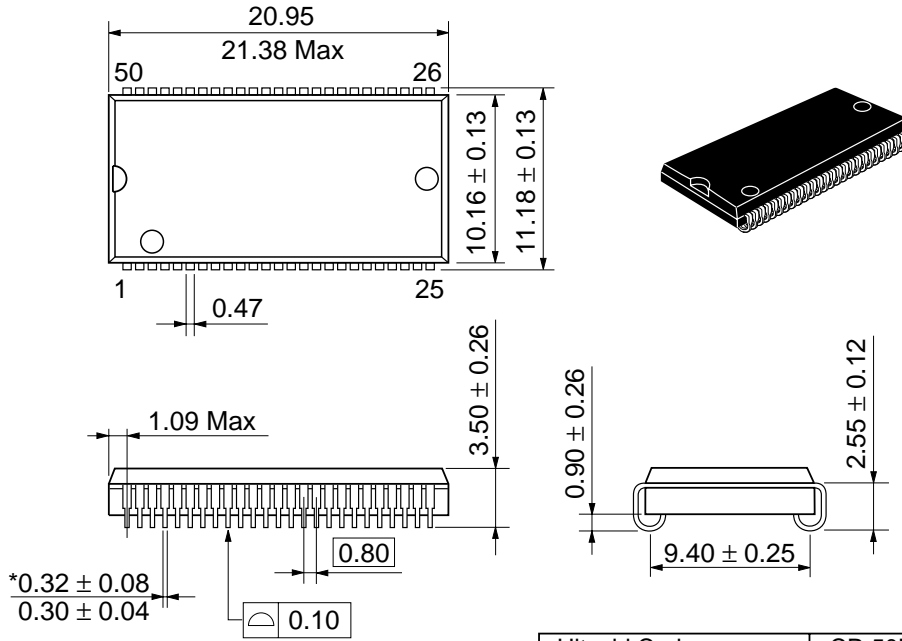

*Dimension including the plating thickness
Base material dimension

Hitachi Code	CP-50DA
JEDEC	Conforms
EIAJ	—
Weight (reference value)	1.2 g

HM5164165FTT/FLTT Series

HM5165165FTT/FLTT Series (TTP-50DB)

Unit: mm

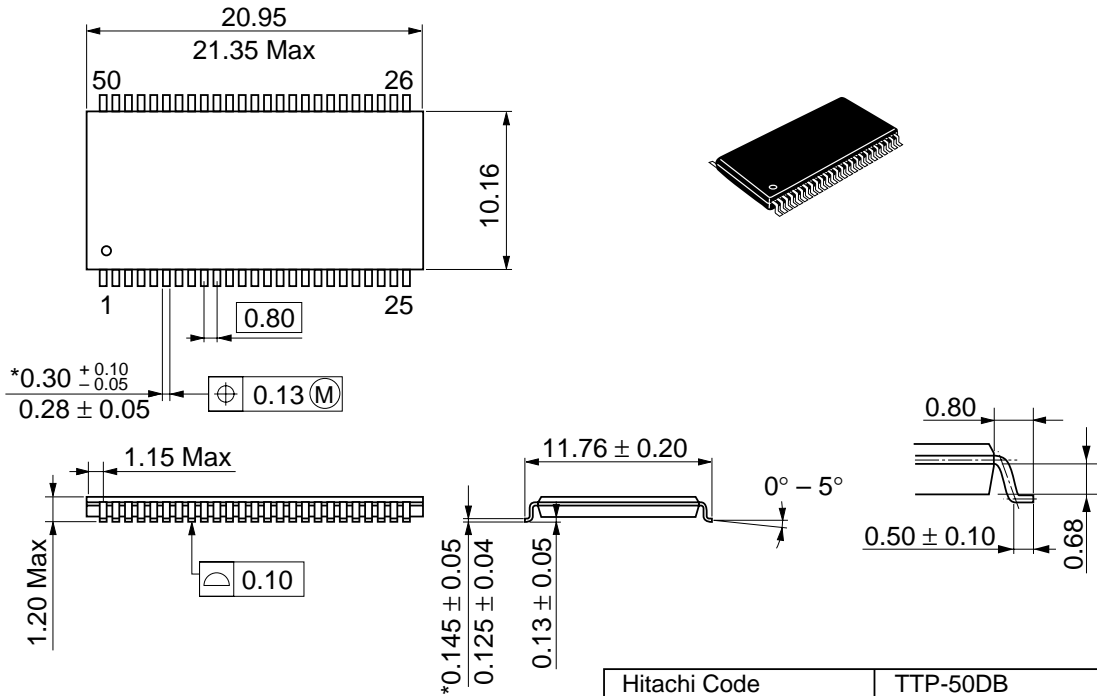

*Dimension including the plating thickness
Base material dimension

Hitachi Code	TTP-50DB
JEDEC	—
EIAJ	—
Weight (reference value)	0.51 g

Cautions

1. Hitachi neither warrants nor grants licenses of any rights of Hitachi's or any third party's patent, copyright, trademark, or other intellectual property rights for information contained in this document. Hitachi bears no responsibility for problems that may arise with third party's rights, including intellectual property rights, in connection with use of the information contained in this document.
2. Products and product specifications may be subject to change without notice. Confirm that you have received the latest product standards or specifications before final design, purchase or use.
3. Hitachi makes every attempt to ensure that its products are of high quality and reliability. However, contact Hitachi's sales office before using the product in an application that demands especially high quality and reliability or where its failure or malfunction may directly threaten human life or cause risk of bodily injury, such as aerospace, aeronautics, nuclear power, combustion control, transportation, traffic, safety equipment or medical equipment for life support.
4. Design your application so that the product is used within the ranges guaranteed by Hitachi particularly for maximum rating, operating supply voltage range, heat radiation characteristics, installation conditions and other characteristics. Hitachi bears no responsibility for failure or damage when used beyond the guaranteed ranges. Even within the guaranteed ranges, consider normally foreseeable failure rates or failure modes in semiconductor devices and employ systemic measures such as fail-safes, so that the equipment incorporating Hitachi product does not cause bodily injury, fire or other consequential damage due to operation of the Hitachi product.
5. This product is not designed to be radiation resistant.
6. No one is permitted to reproduce or duplicate, in any form, the whole or part of this document without written approval from Hitachi.
7. Contact Hitachi's sales office for any questions regarding this document or Hitachi semiconductor products.

HITACHI

Hitachi, Ltd.

Semiconductor & Integrated Circuits.

Nippon Bldg., 2-6-2, Ohte-machi, Chiyoda-ku, Tokyo 100-0004, Japan

Tel: Tokyo (03) 3270-2111 Fax: (03) 3270-5109

URL NorthAmerica : <http://semiconductor.hitachi.com/>
 Europe : <http://www.hitachi-eu.com/hel/ecg>
 Asia (Singapore) : <http://www.has.hitachi.com.sg/grp3/sicd/index.htm>
 Asia (Taiwan) : http://www.hitachi.com.tw/E/Product/SICD_Frame.htm
 Asia (HongKong) : <http://www.hitachi.com.hk/eng/bo/grp3/index.htm>
 Japan : <http://www.hitachi.co.jp/Sicd/indx.htm>

For further information write to:

Hitachi Semiconductor
(America) Inc.
179 East Tasman Drive,
San Jose, CA 95134
Tel: <1> (408) 433-1990
Fax: <1> (408) 433-0223

Hitachi Europe GmbH
Electronic components Group
Dornacher Straße 3
D-85622 Feldkirchen, Munich
Germany
Tel: <49> (89) 9 9180-0
Fax: <49> (89) 9 29 30 00

Hitachi Europe Ltd.
Electronic Components Group.
Whitebrook Park
Lower Cookham Road
Maidenhead
Berkshire SL6 8YA, United Kingdom
Tel: <44> (1628) 585000
Fax: <44> (1628) 778322

Hitachi Asia Pte. Ltd.
16 Collyer Quay #20-00
Hitachi Tower
Singapore 049318
Tel: 535-2100
Fax: 535-1533

Hitachi Asia Ltd.
Taipei Branch Office
3F, Hung Kuo Building, No.167,
Tun-Hwa North Road, Taipei (105)
Tel: <886> (2) 2718-3666
Fax: <886> (2) 2718-8180

Hitachi Asia (Hong Kong) Ltd.
Group III (Electronic Components)
7/F., North Tower, World Finance Centre,
Harbour City, Canton Road, Tsim Sha Tsui,
Kowloon, Hong Kong
Tel: <852> (2) 735 9218
Fax: <852> (2) 730 0281
Telex: 40815 HITEC HX

Copyright © Hitachi, Ltd., 1998. All rights reserved. Printed in Japan.

Revision Record

Rev.	Date	Contents of Modification	Drawn by	Approved by
0.0	May. 25, 1999	Initial issue	M. Kawamura	M. Mishima
1.0	Oct. 5, 1999	Features: Change of Power dissipation Standby (L-version) max: TBD to 1.1 mW DC Characteristics I_{CC2} (L-version) max: TBD/TBD to 300/300 μ A I_{CC10} (L-version) max: TBD/TBD to 1/1 mA I_{CC11} (L-version) max: TBD/TBD to 500/500 μ A	M. Kawamura	Y. Kasama
2.0	Nov. 30, 1999	DC Characteristics I_{CC10} (L-version) max: 1/1 mA to 1.2/1.2 mA		
