



# CMOS 80MHz Monolithic $256 \times 24(18)$ Color Palette RAM-DACs

## ADV478/ADV471

### FEATURES

- Personal System/2\* Compatible
- 80MHz Pipelined Operation
- Triple 8-Bit (6-Bit) D/A Converters
- $256 \times 24(18)$  Color Palette RAM
- $15 \times 24(18)$  Overlay Registers
- RS-343A/RS-170 Compatible Outputs
- Sync on All Three Channels
- Programmable Pedestal (0 or 7.5 IRE)
- External Voltage or Current Reference
- Standard MPU Interface
- +5V CMOS Monolithic Construction
- 44-Pin PLCC Package
- Power Dissipation: 800mW

### APPLICATIONS

- High Resolution Color Graphics
- CAE/CAD/CAM Applications
- Image Processing
- Instrumentation
- Desktop Publishing

### AVAILABLE CLOCK RATES

- 80MHz
- 66MHz
- 50MHz
- 35MHz

### GENERAL DESCRIPTION

The ADV478 (ADV®) and ADV471 are pin compatible and software compatible RAM-DACs designed specifically for Personal System/2 compatible color graphics.

The ADV478 has a  $256 \times 24$  color lookup table with triple 8-bit video D/A converters. It may be configured for either 6 bits or 8 bits per color operation. The ADV471 has a  $256 \times 18$  color lookup table with triple 6-bit video D/A converters.

Options on both parts include a programmable pedestal (0 or 7.5 IRE) and use of an external voltage or current reference.

ADV is a registered trademark of Analog Devices, Inc.

\*Personal System/2 is a trademark of International Business Machines Corp.

### REV. B

Information furnished by Analog Devices is believed to be accurate and reliable. However, no responsibility is assumed by Analog Devices for its use, nor for any infringements of patents or other rights of third parties which may result from its use. No license is granted by implication or otherwise under any patent or patent rights of Analog Devices.

### FUNCTIONAL BLOCK DIAGRAM

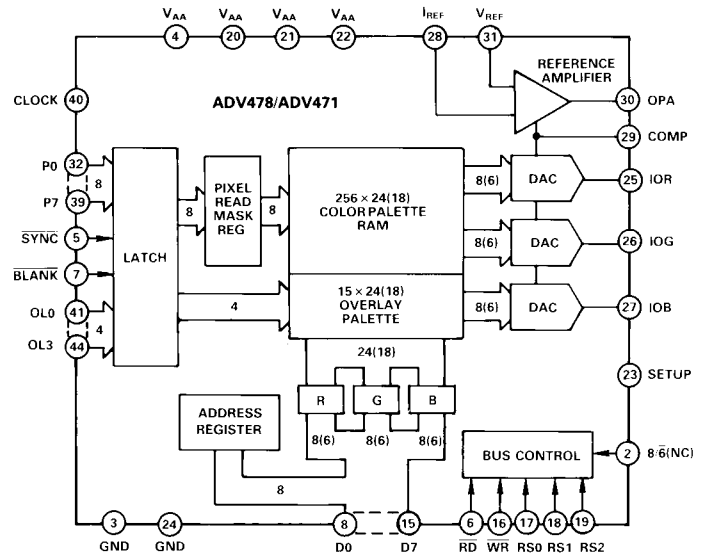

NOTES  
1. NUMBERS IN PARENTHESIS INDICATE PIN NAMES FOR THE ADV471.  
2. NC - NO CONNECT

Fifteen overlay registers provide for overlaying cursors, grids, menus, EGA emulation, etc. Also supported is a pixel read mask register and sync generation on all three channels.

The ADV478 and ADV471 generate RS-343A compatible video signals into a doubly terminated  $75\Omega$  load, and RS-170 compatible video signals into a singly terminated  $75\Omega$  load, without requiring external buffering. Differential and integral linearity errors are guaranteed to be a maximum of  $\pm 1\text{LSB}$  for the ADV478 and  $\pm 1/4\text{LSB}$  for the ADV471 over the full temperature range.

One Technology Way, P.O. Box 9106, Norwood, MA 02062-9106, U.S.A.  
Tel: 617/329-4700 Fax: 617/326-8703 Twx: 710/394-6577  
Telex: 924491 Cable: ANALOG NORWOODMASS

# ADV478/ADV471—SPECIFICATIONS ( $V_{AA}^1 = +5V$ , $SETUP = 8/\bar{6} = V_{AA}$ , $V_{REF} = +1.235V$ , $R_{SET} = 147\Omega$ . All Specifications $T_{min}$ to $T_{max}^2$ unless otherwise noted.)

Parameter	All Versions	Units	Test Conditions/Comments
<b>STATIC PERFORMANCE</b>			
Resolution (Each DAC) <sup>3</sup>	8 (6)	Bits	Guaranteed Monotonic
Accuracy (Each DAC) <sup>3</sup>			
Integral Nonlinearity	± 1 (1/4)	LSB max	
Differential Nonlinearity	± 1 (1/4)	LSB max	
Gray Scale Error	± 5	% Gray Scale max	
Coding	Binary		
<b>DIGITAL INPUTS</b>			
Input High Voltage, $V_{INH}$	2	V min	$V_{IN} = 0.4V$ or $2.4V$
Input Low Voltage, $V_{INL}$	0.8	V max	
Input Current, $I_{IN}$	± 1	μA max	
Input Capacitance, $C_{IN}$	7	pF max	
<b>DIGITAL OUTPUTS</b>			
Output High Voltage, $V_{OH}$	2.4	V min	$I_{SOURCE} = 400\mu A$ $I_{SINK} = 3.2mA$
Output Low Voltage, $V_{OL}$	0.4	V max	
Floating-State Leakage Current	50	μA max	
Floating-State Output Capacitance	7	pF max	
<b>ANALOG OUTPUTS</b>			
Gray Scale Current Range	20	mA max	Typically 19.05mA
Output Current			
White Level Relative to Blank	17.69	mA min	Typically 17.62mA
	20.40	mA max	
White Level Relative to Black	16.74	mA min	Typically 1.44mA
	18.50	mA max	
Black Level Relative to Blank	0.95	mA min	Typically 5μA
( $SETUP = V_{AA}$ )	1.90	mA max	
Black Level Relative to Blank	0	μA min	Typically 7.62mA
( $SETUP = GND$ )	50	μA max	
Blank Level	6.29	mA min	Typically 5μA
	8.96	mA max	
Sync Level	0	μA min	Typically 5μA
	50	μA max	
LSB Size <sup>3</sup>	69.1 (279.68)	μA typ	$8/\bar{6} = \text{Logical 1 for ADV478}$ Typically 2%
DAC to DAC Matching	5	% max	
Output Compliance, $V_{OC}$	-1	V min	
	+1.5	V max	
Output Impedance, $R_{OUT}$	10	kΩ typ	$I_{OUT} = 0mA$
Output Capacitance, $C_{OUT}$	30	pF max	
<b>VOLTAGE REFERENCE</b>			
Voltage Reference Range, $V_{REF}$	1.14/1.26	V min/V max	Tested in Voltage Reference Configuration with $V_{REF} = 1.235V$
Input Current, $I_{VREF}$	10	μA typ	
<b>POWER SUPPLY</b>			
Supply Voltage, $V_{AA}$	4.75/5.25	V min/V max	80MHz and 66MHz Parts 50MHz and 35MHz Parts Typically 180mA $f = 1kHz$ , $COMP = 0.1\mu F$ Typically 900mW, $V_{AA} = 5V$
Supply Current, $I_{AA}$	4.50/5.50	V min/V max	
Power Supply Rejection Ratio	220	mA max	
Power Dissipation	0.5	%/% max	
	1100	mW max	
<b>DYNAMIC PERFORMANCE</b>			
Clock and Data Feedthrough <sup>4,5</sup>	-30	dB typ	
Glitch Impulse <sup>4,5</sup>	75	pV secs typ	
DAC to DAC Crosstalk <sup>6</sup>	-23	dB typ	

## NOTES

<sup>1</sup> ± 5% for 80MHz and 66MHz parts; ± 10% for 50MHz and 35MHz parts.

<sup>2</sup> Temperature Range ( $T_{min}$  to  $T_{max}$ ); 0 to +70°C.

<sup>3</sup> Numbers in parentheses indicate ADV471 parameter value.

<sup>4</sup> Clock and data feedthrough is a function of the amount of overshoot and undershoot on the digital inputs. For this test, the digital inputs have a 1kΩ resistor to ground and are driven by 74HC logic. Glitch impulse includes clock and data feedthrough, -3dB test bandwidth =  $2 \times$  clock rate.

<sup>5</sup> TTL input values are 0 to 3 volts, with input rise/fall times ≤ 3ns, measured between the 10% and 90% points. Timing reference points at 50% for inputs and outputs. Analog output load ≤ 10pF, D0 - D7 output load ≤ 50pF. See timing notes in Figure 2.

<sup>6</sup> DAC to DAC crosstalk is measured by holding one DAC high while the other two are making low to high and high to low transitions.

Specifications subject to change without notice.

**TIMING CHARACTERISTICS<sup>1</sup>** ( $V_{AA}^2 = +5V$ ,  $SETUP = 8/\bar{6} = V_{AA}$ ,  $V_{REF} = 1.235V$ ,  $R_{SET} = 147\Omega$ . All Specifications  $T_{min}$  to  $T_{max}$ <sup>3</sup>.)

Parameter	KP80 Version	KP66 Version	KP50 Version	KP35 Version	Units	Conditions/Comments
$f_{max}$	80	66	50	35	MHz	Clock Rate
$t_1$	10	10	10	10	ns min	RS0 – RS2 Setup Time
$t_2$	10	10	10	10	ns min	RS0 – RS2 Hold Time
$t_3$	5	5	5	5	ns min	$\overline{RD}$ Asserted to Data Bus Driven
$t_4$	40	40	40	40	ns max	$\overline{RD}$ Asserted to Data Valid
$t_5$	20	20	20	20	ns max	$\overline{RD}$ Negated to Data Bus 3-Stated
$t_6$	10	10	10	10	ns min	Write Data Setup Time
$t_7$	10	10	10	10	ns min	Write Data Hold Time
$t_8$	50	50	50	50	ns min	$\overline{RD}$ , $\overline{WR}$ Pulse Width Low
$t_9$	$6 \times t_{12}$	$6 \times t_{12}$	$6 \times t_{12}$	$6 \times t_{12}$	ns min	$\overline{RD}$ , $\overline{WR}$ Pulse Width High
$t_{10}$	3	3	3	3	ns min	Pixel and Control Setup Time
$t_{11}$	3	3	3	3	ns min	Pixel and Control Hold Time
$t_{12}$	12.5	15.3	20	28	ns min	Clock Cycle Time
$t_{13}$	4	5	6	7	ns min	Clock Pulse Width High Time
$t_{14}$	4	5	6	9	ns min	Clock Pulse Width Low Time
$t_{15}$	30	30	30	30	ns max	Analog Output Delay
$t_{16}$	3	3	3	3	ns typ	Analog Output Rise/Fall Time
$t_{17}$ <sup>4</sup>	13	15.3	20	28	ns typ	Analog Output Settling Time
$t_{18}$	2	2	2	2	ns max	Analog Output Skew
$t_{PD}$	$4 \times t_{12}$	$4 \times t_{12}$	$4 \times t_{12}$	$4 \times t_{12}$	ns min	Pipeline Delay

NOTES

<sup>1</sup>TTL input values are 0 to 3 volts, with input rise/fall times  $\leq 3ns$ , measured between the 10% and 90% points. Timing reference points at 50% for inputs and outputs. Analog output load  $\leq 10pF$ , 37.5 $\Omega$ . D0 – D7 output load  $\leq 50pF$ . See timing notes in Figure 2.

<sup>2</sup> $\pm 5\%$  for 80MHz and 66MHz parts;  $\pm 5\%$  for 50MHz and 35MHz parts.

<sup>3</sup>Temperature Range ( $T_{min}$  to  $T_{max}$ ); 0 to +70°C.

<sup>4</sup>Settling time does not include clock and data feedthrough. For this test, the digital inputs have a 1k $\Omega$  resistor to ground and are driven by 74HC logic.

Specifications subject to change without notice

**TIMING DIAGRAMS**

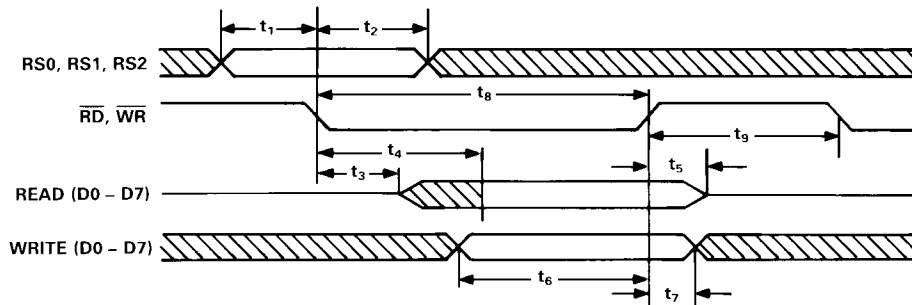
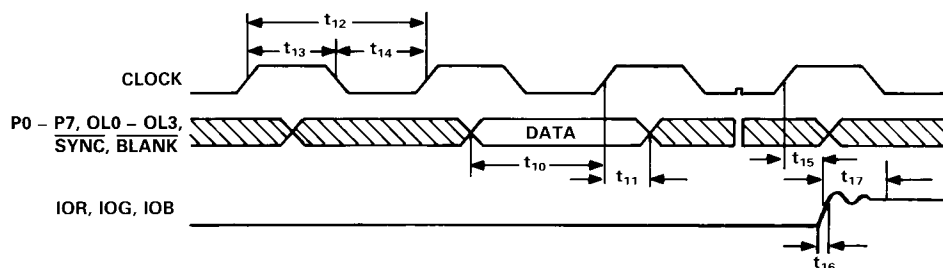

Figure 1. MPU Read/Write Timing



NOTES

1. OUTPUT DELAY ( $t_{15}$ ) MEASURED FROM THE 50% POINT OF THE RISING EDGE OF CLOCK TO THE 50% POINT OF FULL SCALE TRANSITION.
2. SETTLE TIME ( $t_{17}$ ) MEASURED FROM THE 50% POINT OF FULL SCALE TRANSITION TO THE OUTPUT REMAINING WITHIN  $\pm 1LSB$  (ADV478) OR  $\pm 1/4LSB$  (ADV471).
3. OUTPUT RISE/FALL TIME ( $t_{16}$ ) MEASURED BETWEEN THE 10% AND 90% POINTS OF FULL SCALE TRANSITION.

Figure 2. Video Input/Output Timing

# ADV478/ADV471

## RECOMMENDED OPERATING CONDITIONS

Parameter	Symbol	Min	Typ	Max	Units
Power Supply	$V_{AA}$				
80MHz, 66MHz Parts		4.75	5.00	5.25	Volts
50, 35MHz Parts		4.5	5.00	5.5	Volts
Ambient Operating Temperature	$T_A$	0		+70	°C
Output Load	$R_L$		37.5		$\Omega$
Voltage Reference Configuration					
Reference Voltage	$V_{REF}$	1.14	1.235	1.26	Volts
Current Reference Configuration					
Reference Current	$I_{REF}$	-3		-10	mA

### CAUTION

ESD (electrostatic discharge) sensitive device. The digital control inputs are diode protected; however, permanent damage may occur on unconnected devices subject to high energy electrostatic fields. Unused devices must be stored in conductive foam or shunts. The protective foam should be discharged to the destination socket before devices are removed.



### ABSOLUTE MAXIMUM RATINGS\*

$V_{AA}$ to GND	+7V
Voltage on Any Digital Pin	GND -0.5V to $V_{AA}$ +0.5V
Ambient Operating Temperature ( $T_A$ )	-55°C to +125°C
Storage Temperature ( $T_S$ )	-65°C to +150°C
Lead Temperature (Soldering, 10 secs)	+300°C
Junction Temperature ( $T_J$ )	+150°C
Vapor Phase Soldering (1 minute)	220°C
IOR, IOB, IOG to GND <sup>1</sup>	0V to $V_{AA}$

### NOTES

\*Stresses above those listed under "Absolute Maximum Ratings" may cause permanent damage to the device. This is a stress rating only and functional operation of the device at these or any other conditions above those listed in the operational sections of this specification is not implied. Exposure to absolute maximum rating conditions for extended periods may affect device reliability.

<sup>1</sup>Analog output short circuit to any power supply or common can be of an indefinite duration.

### PLCC PIN CONFIGURATION

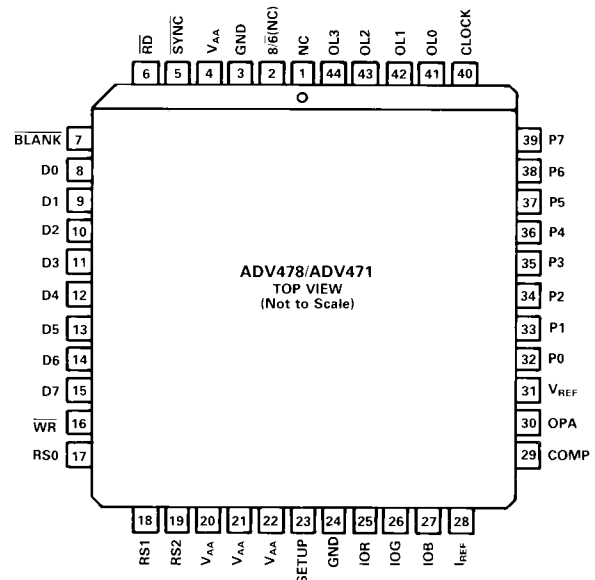

### NOTES

- NUMBERS IN PARENTHESIS INDICATE PIN NAMES FOR THE ADV471.
- NC = NO CONNECT

### ORDERING GUIDE

Model	Temperature Range	Color Palette RAM	Speed	Package Option*
ADV471KP80	0°C to +70°C	256 × 18	80MHz	P-44A
ADV471KP66	0°C to +70°C	256 × 18	66MHz	P-44A
ADV471KP50	0°C to +70°C	256 × 18	50MHz	P-44A
ADV471KP35	0°C to +70°C	256 × 18	35MHz	P-44A
ADV478KP80	0°C to +70°C	256 × 24	80MHz	P-44A
ADV478KP66	0°C to +70°C	256 × 24	66MHz	P-44A
ADV478KP50	0°C to +70°C	256 × 24	50MHz	P-44A
ADV478KP35	0°C to +70°C	256 × 24	35MHz	P-44A

\*P = Plastic Leaded Chip Carrier (PLCC).

PIN FUNCTION DESCRIPTION

Pin Mnemonic	Function																				
BLANK	Composite blank control input (TTL compatible). A logic zero drives the analog outputs to the blanking level as illustrated in Tables IV and V. It is latched on the rising edge of CLOCK. When $\overline{\text{BLANK}}$ is a logical zero, the pixel and overlay inputs are ignored																				
SETUP	Setup control input. Used to specify either a 0 IRE (SETUP = GND) or 7.5 IRE (SETUP = $V_{AA}$ ) blanking pedestal.																				
$\overline{\text{SYNC}}$	Composite sync control input (TTL compatible). A logical zero on this input switches off a 40 IRE current source on the analog outputs (see Figures 3 and 4). $\overline{\text{SYNC}}$ does not override any other control or data input, as shown in Tables IV and V; therefore, it should be asserted only during the blanking interval. It is latched on the rising edge of CLOCK.																				
CLOCK	Clock input (TTL compatible). The rising edge of CLOCK latches the P0 – P7, OL0 – OL3, $\overline{\text{SYNC}}$ , and $\overline{\text{BLANK}}$ inputs. It is typically the pixel clock rate of the video system. It is recommended that CLOCK be driven by a dedicated TTL buffer.																				
P0 – P7	Pixel select inputs (TTL compatible). These inputs specify, on a pixel basis, which one of the 256 entries in the color palette RAM is to be used to provide color information. They are latched on the rising edge of CLOCK. P0 is the LSB. Unused inputs should be connected to GND.																				
OL0 – OL3	Overlay select inputs (TTL compatible). These inputs specify which palette is to be used to provide color information, as illustrated in Table III. When accessing the overlay palette, the P0 – P7 inputs are ignored. They are latched on the rising edge of CLOCK. OL0 is the LSB. Unused inputs should be connected to GND.																				
IOR, IOG, IOB	Red, green, and blue current outputs. These high impedance current sources are capable of directly driving a doubly terminated 75Ω coaxial cable (Figures 5 and 6).																				
$I_{REF}$	<p>Full-scale adjust control. Note that the IRE relationships in Figures 3 and 4 are maintained, regardless of the full-scale output current.</p> <p>When using an external voltage reference (Figure 5), a resistor (<math>R_{SET}</math>) connected between this pin and GND controls the magnitude of the full-scale video signal. The relationship between <math>R_{SET}</math> and the full-scale output current on each output is:</p> $R_{SET} (\Omega) = K * 1,000 * V_{REF} (V) / I_{OUT} (mA)$ <p>K is defined in the table below, along with corresponding <math>R_{SET}</math> values for doubly terminated 75Ω loads.</p> <p>When using an external current reference (Figure 6), the relationship between <math>I_{REF}</math> and the full-scale output current on each output is:</p> $I_{REF} (mA) = I_{OUT} (mA) / K$ <table border="1" style="margin-left: auto; margin-right: auto;"> <thead> <tr> <th>Mode</th> <th>Pedestal</th> <th>K</th> <th><math>R_{SET} (\Omega)</math></th> </tr> </thead> <tbody> <tr> <td>6-Bit</td> <td>7.5 IRE</td> <td>3.170</td> <td>147</td> </tr> <tr> <td>8-Bit</td> <td>7.5 IRE</td> <td>3.195</td> <td>147</td> </tr> <tr> <td>6-Bit</td> <td>0 IRE</td> <td>3.000</td> <td>147</td> </tr> <tr> <td>8-Bit</td> <td>0 IRE</td> <td>3.025</td> <td>147</td> </tr> </tbody> </table>	Mode	Pedestal	K	$R_{SET} (\Omega)$	6-Bit	7.5 IRE	3.170	147	8-Bit	7.5 IRE	3.195	147	6-Bit	0 IRE	3.000	147	8-Bit	0 IRE	3.025	147
Mode	Pedestal	K	$R_{SET} (\Omega)$																		
6-Bit	7.5 IRE	3.170	147																		
8-Bit	7.5 IRE	3.195	147																		
6-Bit	0 IRE	3.000	147																		
8-Bit	0 IRE	3.025	147																		
COMP	Compensation pin. If an external voltage reference is used (Figure 5), this pin should be connected to OPA. If an external current reference is used, this pin should be connected to $I_{REF}$ . A 0.1μF ceramic capacitor must always be used to bypass this pin to $V_{AA}$ .																				
$V_{REF}$	Voltage reference input. If an external voltage reference is used (Figure 5), it must supply this input with a 1.2V (typical) reference. If an external current reference is used (Figure 6), this pin should be left floating, except for the bypass capacitor. A 0.1μF ceramic capacitor must always be used to decouple this input to $V_{AA}$ as shown in Figures 5 and 6.																				
OPA	Reference amplifier output. If an external voltage reference is used (Figure 5), this pin must be connected to COMP. When using an external current reference (Figure 6), this pin should be left floating.																				
$V_{AA}$	Analog power. All $V_{AA}$ pins must be connected to the Analog Power Plane.																				
GND	Analog ground. All GND pins must be connected to the Ground Plane.																				
$\overline{\text{WR}}$	Write control input (TTL compatible). D0 – D7 data is latched on the rising edge of $\overline{\text{WR}}$ , and RS0 – RS2 are latched on the falling edge of $\overline{\text{WR}}$ during MPU write operations. See Figure 1.																				

## PIN FUNCTION DESCRIPTION (Continued)

Pin Mnemonic	Function
$\overline{RD}$	Read control input (TTL compatible). To read data from the device, $\overline{RD}$ must be a logical zero. RS0 – RS2 are latched on the falling edge of $\overline{RD}$ during MPU read operations.
RS0, RS1, RS2	Register select inputs (TTL compatible). RS0 – RS2 specify the type of read or write operation being performed as illustrated in Tables I and II.
D0 – D7	Data bus (TTL compatible). Data is transferred into and out of the device over this 8-bit bidirectional data bus. D0 is the least significant bit.
$8/\overline{6}$	8-bit/6-bit select input (TTL compatible). This control input specifies whether the MPU is reading and writing 8-bits (logical one) or 6-bits (logical zero) of color information each cycle. For 8-bit operation, D7 is the most significant data bit during color read/write cycles. For 6-bit operation, D5 is the most significant data bit during color read/write cycles (D6 and D7 are ignored during color write cycles and are logical zero during color read cycles). This control input is implemented only on the ADV478.

## TERMINOLOGY

### Blanking Level

The level separating the SYNC portion from the video portion of the waveform. Usually referred to as the front porch or back porch. At 0 IRE units, it is the level which will shut off the picture tube, resulting in the blackest possible picture.

### Color Video (RGB)

This usually refers to the technique of combining the three primary colors of red, green and blue to produce color pictures within the usual spectrum. In RGB monitors, three DACs would be required, one for each color.

### Composite SYNC Signal (SYNC)

The portion of the composite video signal which synchronizes the scanning process.

### Composite Video Signal

The video signal with or without setup, plus the composite SYNC signal.

### Gray Scale

The discrete levels of video signal between reference black and reference white levels. An 8-bit DAC contains 256 different levels while a 6-bit DAC contains 64.

### Raster Scan

The most basic method of sweeping a CRT one line at a time to generate and display images.

### Reference Black Level

The maximum negative polarity amplitude of the video signal.

### Reference White Level

The maximum positive polarity amplitude of the video signal.

### Setup

The difference between the reference black level and the blanking level.

### SYNC Level

The peak level of the composite SYNC signal.

### Video Signal

That portion of the composite video signal which varies in gray scale levels between reference white and reference black. Also referred to as the picture signal, this is the portion which may be visually observed.

**CIRCUIT DESCRIPTION**

**MPU Interface**

As illustrated in the functional block diagram, the ADV478 and ADV471 support a standard MPU bus interface, allowing the MPU direct access to the color palette RAM and overlay color registers.

The RS0 – RS2 select inputs specify whether the MPU is accessing the address register, color palette RAM, overlay registers or read mask register, as shown in Table I. The 8-bit address register is used to address the color palette RAM and overlay registers, eliminating the requirement for external address multiplexers.

To write color data, the MPU writes to the address register (selecting RAM or overlay write mode) with the address of the color palette RAM location or overlay register to be modified. The MPU performs three successive write cycles (8 or 6 bits each of red, green and blue), using RS0 – RS2 to select either the color palette RAM or overlay registers. During the blue write cycle, the three bytes of color information are concatenated into a 24-bit word (18-bit word for the ADV471) and written to the location specified by the address register. The address register then increments to the next location which the MPU may modify by simply writing another sequence of red, green and blue data.

RS2	RS1	RS0	Addressed by MPU
0	0	0	Address Register (RAM Write Mode)
0	1	1	Address Register (RAM Read Mode)
0	0	1	Color Palette RAM
0	1	0	Pixel Read Mask Register
1	0	0	Address Register (Overlay Write Mode)
1	1	1	Address Register (Overlay Read Mode)
1	0	1	Overlay Registers
1	1	0	Reserved

Table I. Control Input Truth Table

To read color data, the MPU loads the address register (selecting RAM or overlay read mode) with the address of the color palette RAM location or overlay register to be read. The MPU performs three successive read cycles (8 or 6 bits each of red, green and blue), using RS0 – RS2 to select either the color palette RAM or overlay registers. Following the blue read cycle, the address register increments to the next location which the MPU may read by simply reading another sequence of red, green and blue data.

When accessing the color palette RAM, the address register resets to 00H following a blue read or write cycle to RAM location FFH. When accessing the overlay color registers, the address register increments following a blue read or write cycle. However, while accessing the overlay color registers, the four most significant bits of the address register (ADDR4 – 7) are ignored.

The MPU interface operates asynchronously to the pixel clock. Data transfers between the color palette RAM/overlay registers and the color registers (R, G and B in the block diagram) are synchronized by internal logic and occur in the period between MPU accesses. As only one pixel clock cycle is required to complete the transfer, the color palette RAM and overlay registers may be accessed at any time with no noticeable disturbance on the display screen.

To keep track of the red, green and blue read/write cycles, the address register has two additional bits (ADDRa, ADDRb) that count modulo three, as shown in Table II. They are reset to zero when the MPU writes to the address register and are not reset to zero when the MPU reads the address register. The MPU does not have access to these bits. The other eight bits of the address register, incremented following a blue read or write cycle (ADDR0 – 7), are accessible to the MPU and are used to address color palette RAM locations and overlay registers, as shown in Table II. ADDR0 is the LSB when the MPU is accessing the RAM or overlay registers. The MPU may read the address register at any time without modifying its contents or the existing read/write mode.

Figure 1 illustrates the MPU read/write timing.

	Value	RS2	RS1	RS0	Addressed By MPU
ADDRa,b (Counts Modulo 3)	00				Red Value
	01				Green Value
	10				Blue Value
ADDR0 – 7 (Counts Binary)	00H – FFH	0	0	1	Color Palette RAM
	XXXX 0000	1	0	1	Reserved
	XXXX 0001	1	0	1	Overlay Color 1
	XXXX 0010	1	0	1	Overlay Color 2
	.	.	.	.	.
	.	.	.	.	.
	XXXX 1111	1	0	1	Overlay Color 15

Table II. Address Register (ADDR) Operation

# ADV478/ADV471

## ADV478 Data Bus Interface

On the ADV478, the  $8/\bar{6}$  control input is used to specify whether the MPU is reading and writing 8 bits ( $8/\bar{6}$  = logical one) or 6 bits ( $8/\bar{6}$  = logical zero) of color information each cycle.

For 8-bit operation, D0 is the LSB and D7 is the MSB of color data.

For 6-bit operation (and also when using the ADV471), color data is contained on the lower six bits of the data bus, with D0 being the LSB and D5 the MSB of color data. When writing color data, D6 and D7 are ignored. During color read cycles, D6 and D7 will be a logical zero.

## ADV471 Data Bus Interface

Color data is contained on the lower six bits of the data bus, with D0 being the LSB and D5 the MSB of color data. When writing color data, D6 and D7 are ignored. During color read cycles, D6 and D7 will be a logical zero.

## Frame Buffer Interface

The P0 – P7 and OL0 – OL3 inputs are used to address the color palette RAM and overlay registers, as shown in Table III.

OL0 – OL3	P0 – P7	Addressed by Frame Buffer
0H	00H	Color Palette RAM Location 00H
0H	01H	Color Palette RAM Location 01H
⋮	⋮	⋮
⋮	⋮	⋮
0H	FFH	Color Palette RAM Location FFH
1H	XXH	Overlay Color 1
2H	XXH	Overlay Color 2
⋮	⋮	⋮
⋮	⋮	⋮
FH	XXH	Overlay Color 15

Table III. Pixel and Overlay Control Truth Table (Pixel Read Mask Register = FFH)

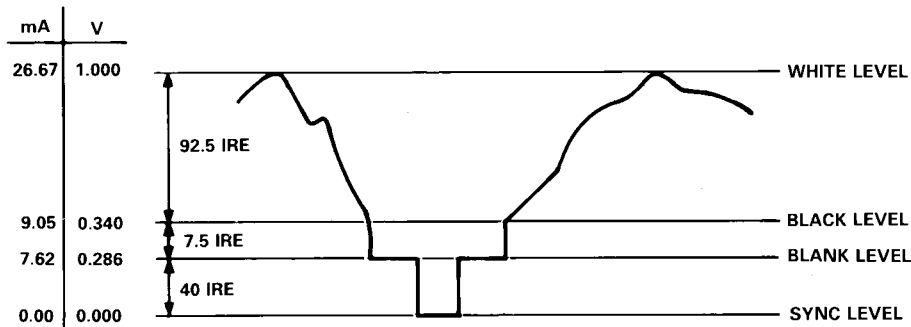

### NOTES

1. CONNECTED WITH A 75Ω DOUBLY TERMINATED LOAD, SETUP = V<sub>AA</sub>.
2. EXTERNAL VOLTAGE OR CURRENT REFERENCE ADJUSTED FOR 26.67mA FULL-SCALE OUTPUT.
3. RS-343A LEVELS AND TOLERANCES ASSUMED ON ALL LEVELS.

Figure 3. Composite Video Output Waveform (SETUP = V<sub>AA</sub>)

Description	I <sub>OUT</sub> (mA) <sup>1</sup>	$\overline{\text{SYNC}}$	$\overline{\text{BLANK}}$	DAC Input Data
WHITE LEVEL	26.67	1	1	FFH
DATA	data + 9.05	1	1	data
DATA-SYNC	data + 1.44	0	1	data
BLACK LEVEL	9.05	1	1	00H
BLACK-SYNC	1.44	0	1	00H
BLANK LEVEL	7.62	1	0	xxH
SYNC LEVEL	0	0	0	xxH

### NOTES

- <sup>1</sup>Typical with full-scale IOG = 26.67mA, SETUP = V<sub>AA</sub>.  
External voltage or current reference adjusted for 26.67mA full-scale output.

Table IV. Video Output Truth Table (SETUP = V<sub>AA</sub>)



The contents of the pixel read mask register, which may be accessed by the MPU at any time, are bit-wise logically ANDed with the P0 – P7 inputs. Bit D0 of the pixel read mask register corresponds to pixel input P0. The addressed location provides 24 bits (18 bits for the ADV471) of color information to the three D/A converters.

For additional information on Pixel Mask Register, see application note “Animation Using the Pixel Read Mask Register of the ADV47X Series of Video RAM-DACs”(Publication Number E1316–15–10/89).

The  $\overline{\text{SYNC}}$  and  $\overline{\text{BLANK}}$  inputs, also latched on the rising edge

of  $\overline{\text{CLOCK}}$  to maintain synchronization with the color data, add appropriately weighted currents to the analog outputs, producing the specific output levels required for video applications, as illustrated in Figures 3 and 4. Tables IV and V detail how the  $\overline{\text{SYNC}}$  and  $\overline{\text{BLANK}}$  inputs modify the output levels.

The  $\overline{\text{SETUP}}$  input is used to specify whether a 0 IRE ( $\overline{\text{SETUP}} = \text{GND}$ ) or 7.5 IRE ( $\overline{\text{SETUP}} = V_{\text{AA}}$ ) blanking pedestal is to be used.

The analog outputs of the ADV478 and ADV471 are capable of directly driving a 37.5Ω load, such as a doubly terminated 75Ω coaxial cable.

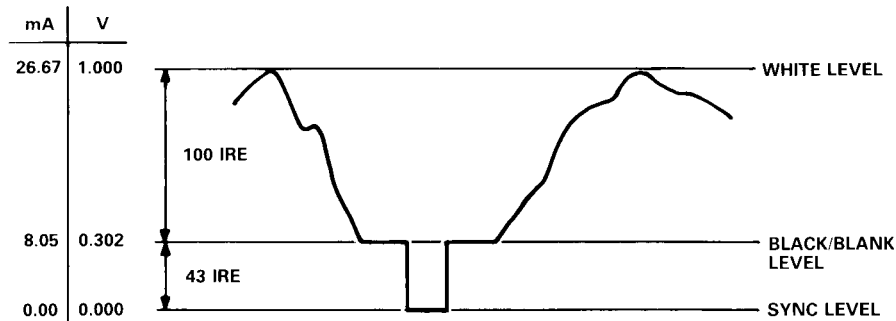

**NOTES**

1. CONNECTED WITH A 75Ω DOUBLY TERMINATED LOAD,  $\overline{\text{SETUP}} = \text{GND}$ .
2. EXTERNAL VOLTAGE OR CURRENT REFERENCE ADJUSTED FOR 26.67mA FULL-SCALE OUTPUT.
3. RS-343A LEVELS AND TOLERANCES ASSUMED ON ALL LEVELS.

Figure 4. Composite Video Output Waveform ( $\overline{\text{SETUP}} = \text{GND}$ )

Description	$I_{\text{OUT}}(\text{mA})^1$	$\overline{\text{SYNC}}$	$\overline{\text{BLANK}}$	DAC Input Data
WHITE LEVEL	26.67	1	1	FFH
DATA	data + 8.05	1	1	data
DATA-SYNC	data	0	1	data
BLACK LEVEL	8.05	1	1	00H
BLACK-SYNC	0	0	1	00H
BLANK LEVEL	8.05	1	0	xxH
SYNC LEVEL	0	0	0	xxH

**NOTES**

- <sup>1</sup>Typical with full-scale IOG = 26.67mA,  $\overline{\text{SETUP}} = \text{GND}$   
External voltage or current reference adjusted for 26.67mA full-scale output.

Table V. Video Output Truth Table ( $\overline{\text{SETUP}} = \text{GND}$ )

# ADV478/ADV471

## PC BOARD LAYOUT CONSIDERATIONS

### PC Board Considerations

The layout should be optimized for lowest noise on the ADV478/ADV471 power and ground lines by shielding the digital inputs and providing good decoupling. The lead length between groups of  $V_{AA}$  and GND pins should be minimized so as to minimize inductive ringing.

### Ground Planes

The ground plane should encompass all ADV478/ADV471 ground pins, current/voltage reference circuitry, power supply bypass circuitry for the ADV478/ADV471, the analog output traces and all the digital signal traces leading up to the ADV478/ADV471.

### Power Planes

The ADV478/ADV471 and any associated analog circuitry should have its own power plane, referred to as the analog power plane. This power plane should be connected to the regular PCB power plane ( $V_{CC}$ ) at a single point through a ferrite bead, as illustrated in Figures 5 and 6. This bead should be located within three inches of the ADV478/ADV471.

The PCB power plane should provide power to all digital logic on the PC board, and the analog power plane should provide

power to all ADV478/ADV471 power pins and current/voltage reference circuitry.

Plane-to-plane noise coupling can be reduced by ensuring that portions of the regular PCB power and ground planes do not overlay portions of the analog power plane, unless they can be arranged such that the plane-to-plane noise is common mode.

### Supply Decoupling

For optimum performance, bypass capacitors should be installed using the shortest leads possible, consistent with reliable operation, to reduce the lead inductance.

Best performance is obtained with a  $0.1\mu\text{F}$  ceramic capacitor decoupling each of the two groups of  $V_{AA}$  pins to GND. These capacitors should be placed as close as possible to the device.

It is important to note that while the ADV478 and ADV471 contain circuitry to reject power supply noise, this rejection decreases with frequency. If a high frequency switching power supply is used, the designer should pay close attention to reducing power supply noise and consider using a three terminal voltage regulator for supplying power to the analog power plane.

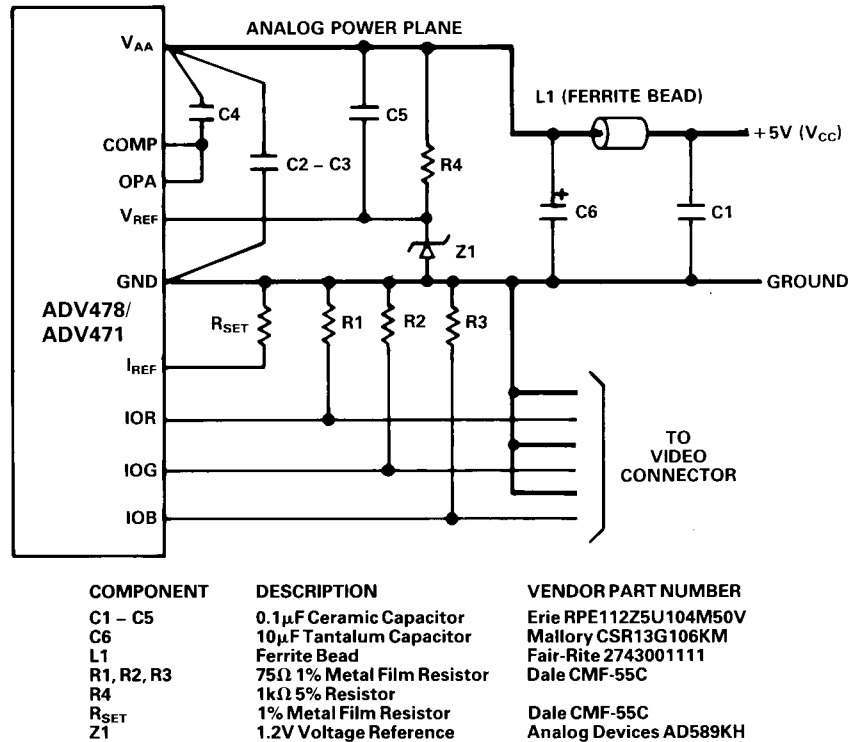

Figure 5. Typical Connection Diagram and Component List (External Voltage Reference)

### Digital Signal Interconnect

The digital inputs to the ADV478/ADV471 should be isolated as much as possible from the analog outputs and other analog circuitry. Also, these input signals should not overlay the analog power plane.

Due to the high clock rates involved, long clock lines to the ADV478/ADV471 should be avoided to reduce noise pickup.

Any active termination resistors for the digital inputs should be connected to the regular PCB power plane ( $V_{CC}$ ), and not the analog power plane.

### Analog Signal Interconnect

The ADV478/ADV471 should be located as close as possible to the output connectors to minimize noise pickup and reflections due to impedance mismatch.

The video output signals should overlay the ground plane, and not the analog power plane, to maximize the high frequency power supply rejection.

For maximum performance, the analog outputs should each have a  $75\Omega$  load resistor connected to GND. The connection between the current output and GND should be as close as possible to the ADV478/ADV471 to minimize reflections.

NOTE: Additional information on PC Board layout can be obtained in an application note entitled "Design and Layout of a Video Graphics System for Reduced EMI" from Analog Devices (Publication Note E1309-15-10/89).

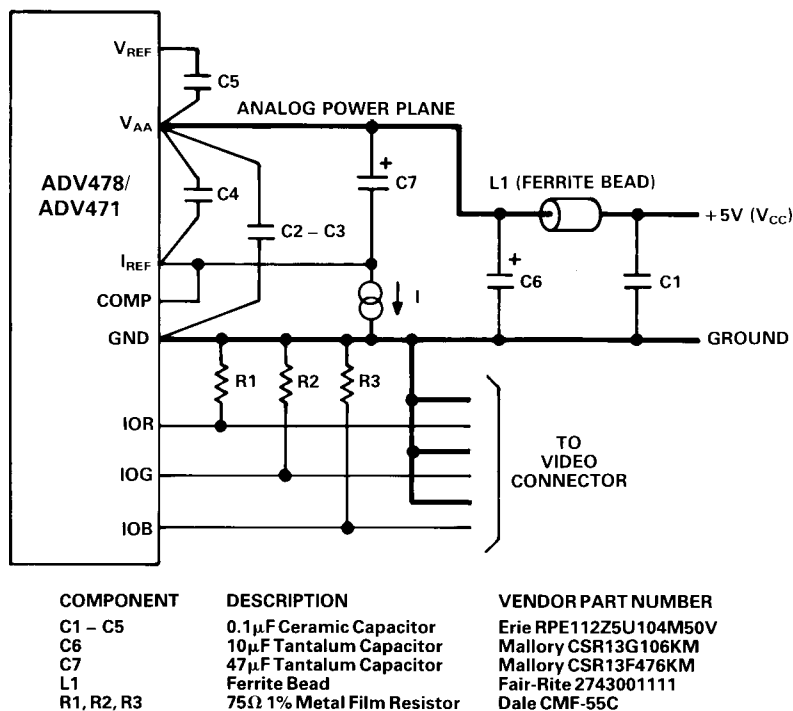

Figure 6. Typical Connection Diagram and Component List (External Current Reference)

### APPLICATION INFORMATION

#### External Voltage vs. Current Reference

The ADV478/ADV471 is designed to have excellent performance using either an external voltage or current reference. The voltage reference design (Figure 5) has the advantages of temperature compensation, simplicity, lower cost and provides excellent power supply rejection. The current reference design (Figure 6) requires more components to provide adequate power supply rejection and temperature compensation (two transistors, three resistors and additional capacitors).

#### RS-170 Video Generation

For generation of RS-170 compatible video, it is recommended that the DAC outputs be connected to a singly terminated  $75\Omega$  load. If the ADV478/ADV471 is not driving a large capacitive load, there will be negligible difference in video quality between doubly terminated  $75\Omega$  and singly terminated  $75\Omega$  loads.

If driving a large capacitive load (load  $RC > 1/(2\pi f_C)$ ), it is recommended that an output buffer (such as an AD848 or AD9617 with an unloaded gain  $> 2$ ) be used to drive a doubly terminated  $75\Omega$  load.

**OUTLINE DIMENSIONS**

Dimensions shown in inches and (mm).

**44-Terminal Plastic Leaded Chip Carrier  
P-44A**

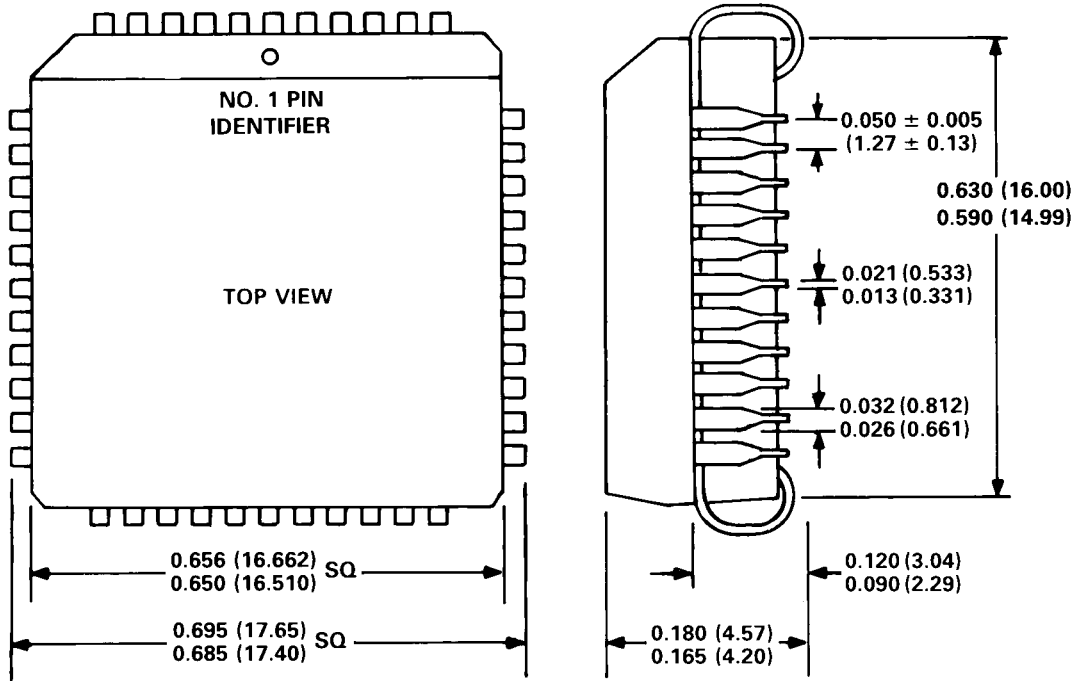

C1197 - 24 - 6/88

PRINTED IN U.S.A.