

Surface Mount LED Indicator

Technical Data

HSMD-TX00
HSME-TX00
HSMG-TX00
HSMH-TX00
HSMS-TX00
HSMY-TX00

Features

- **Compatible with Automatic Placement Equipment**
- **Compatible with Infrared and Vapor Phase Reflow Solder Processes**
- **Packaged in 12 mm or 8 mm tape on 7" or 13" Diameter Reels**
- **EIA Standard Package**
- **Low Package Profile**
- **Nondiffused Package Excellent for Backlighting and Coupling to Light Pipes**

Description

These solid state surface mount indicators are designed with a flat top and sides to be easily handled by automatic placement equipment. A glue pad is provided for adhesive mounting processes. They are compatible with convective IR and vapor phase reflow soldering and conductive epoxy attachment processes.

The package size and configuration conform to the EIA-535 BAAC standard specification for case size 3528 tantalum capacitors. The folded leads



permit dense placement and provide an external solder joint for ease of inspection.

These devices are nondiffused, providing high intensity for applications such as backlighting, light pipe illumination, and front panel indication.

Device Selection Guide

DH AS AlGaAs Red HSMH-	High Efficiency Red HSMS-	Orange HSMD-	Yellow HSMY-	High Performance Green HSMG-	Emerald Green HSME-	Description
T400	T400	T400	T400	T400	T400	12 mm Tape, 7" Reel, 2000 Devices
T500	T500	T500	T500	T500	T500	12 mm Tape, 13" Reel, 8000 Devices
T600	T600	T600	T600	T600	T600	8 mm Tape, 7" Reel, 2000 Devices
T700	T700	T700	T700	T700	T700	8 mm Tape, 13" Reel, 8000 Devices

Package Dimensions

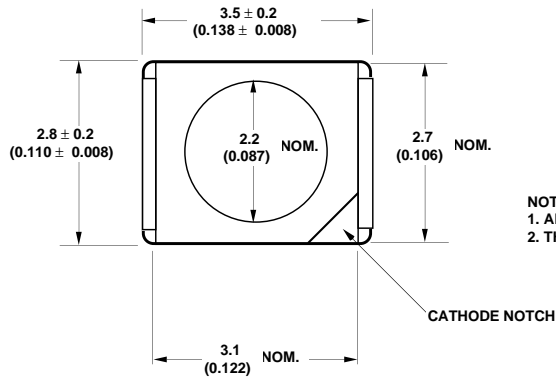

- NOTES:
 1. ALL DIMENSIONS ARE IN MILLIMETERS (INCHES).
 2. THE LEADS ARE COPPER ALLOY, 85% Sn/15% Pb PLATING.

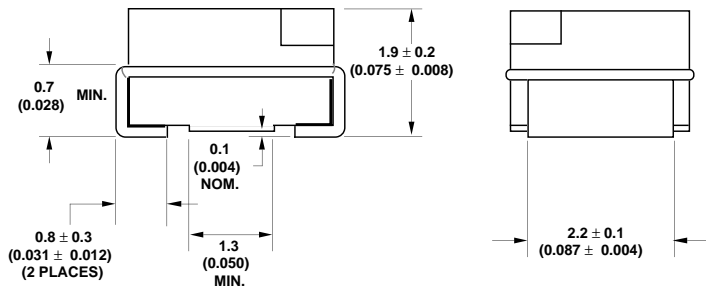

Tape and Reel Specifications

Hewlett Packard surface mount LEDs are packaged tape and reel in accordance with EIA-481A, *Taping of Surface Mount*

Components for Automatic Placement. This packaging system is compatible with tape-fed automatic pick and place systems. Each reel is sealed in a

vapor barrier bag for added protection. Bulk packaging in vapor barrier bags is available upon special request.

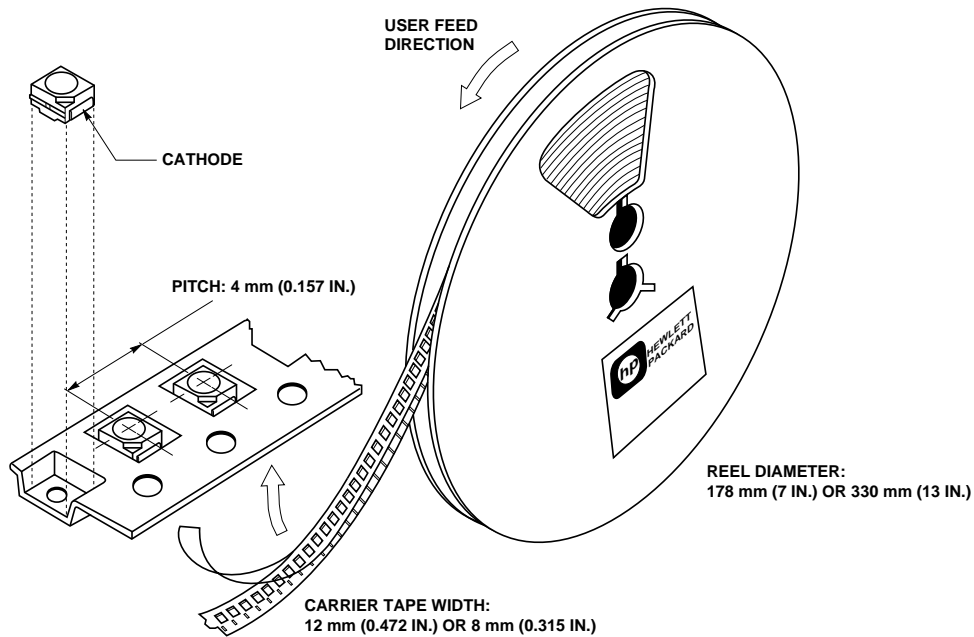

Absolute Maximum Ratings at $T_A = 25^\circ\text{C}$

Parameter	DH AS AlGaAs Red	High Efficiency Red	Orange	Yellow	High Perf. Green	Emerald Green	Units
DC Forward Current ^[1]	30	30	30	30	30	30	mA
Peak Forward Current ^[2]	300	90	90	60	90	90	mA
Average Forward Current ^[2]	20	25	25	20	25	25	mA
LED Junction Temperature	95						$^\circ\text{C}$
Transient Forward Current ^[3] (10 μs Pulse)	500						mA
Reverse Voltage ($I_R = 100\text{ mA}$)	5						V
Operating Temperature Range	-40 to +85					-20 to +85	$^\circ\text{C}$
Storage Temperature Range	-40 to +85						$^\circ\text{C}$
Reflow Soldering Temperature Convective IR Vapor Phase	235 $^\circ\text{C}$ Peak, above 185 $^\circ\text{C}$ for 90 seconds. 215 $^\circ\text{C}$ for 3 minutes.						

Notes:

1. Derate dc current linearly from 50 $^\circ\text{C}$: For AlGaAs red, high efficiency red, and green devices at 0.67 mA/ $^\circ\text{C}$. For yellow devices at 0.44 mA/ $^\circ\text{C}$.
2. Refer to Figure 5 showing Maximum Tolerable Peak Current vs. Pulse duration to establish pulsed operating conditions.
3. The transient peak current is the maximum non-recurring peak current the device can withstand without damaging the LED die and wire bond. The device should not be operated at peak currents above the Absolute Maximum Peak Forward Current.

Electrical/Optical Characteristics at $T_A = 25^\circ\text{C}$

DH AS AlGaAs Red HSMH-TX00

Parameter	Symbol	Min.	Typ.	Max.	Units	Test Conditions
Luminous Intensity	I_v	9.0	17.0		mcd	$I_F = 10\text{ mA}$
Forward Voltage	V_F		1.8	2.2	V	$I_F = 10\text{ mA}$
Reverse Breakdown Voltage	V_R	5.0	15.0		V	$I_R = 100\ \mu\text{A}$
Included Angle Between Half Intensity Points ^[1]	$2\theta_{1/2}$		120		deg.	
Peak Wavelength	λ_{PEAK}		645		nm	
Dominant Wavelength ^[2]	λ_d		637		nm	
Spectral Line Half Width	$\Delta\lambda_{1/2}$		20		nm	
Speed of Response	τ_s		30		ns	Time Constant, e^{-t/τ_s}
Capacitance	C		30		pF	$V_F = 0, f = 1\text{ MHz}$
Thermal Resistance	$R\theta_{\text{J-pin}}$		180		$^\circ\text{C/W}$	Junction-to-Cathode
Luminous Efficacy ^[3]	η_v		80		lm/W	

High Efficiency Red HSMS-TX00

Parameter	Symbol	Min.	Typ.	Max.	Units	Test Conditions
Luminous Intensity	I_v	2.0	6.0		mcd	$I_F = 10\text{ mA}$
Forward Voltage	V_F		1.9	2.5	V	$I_F = 10\text{ mA}$
Reverse Breakdown Voltage	V_R	5.0	30.0		V	$I_R = 100\ \mu\text{A}$
Included Angle Between Half Intensity Points ^[1]	$2\theta_{1/2}$		120		deg.	
Peak Wavelength	λ_{PEAK}		635		nm	
Dominant Wavelength ^[2]	λ_d		626		nm	
Spectral Line Half Width	$\Delta\lambda_{1/2}$		40		nm	
Speed of Response	τ_s		90		ns	Time Constant, e^{-t/τ_s}
Capacitance	C		11		pF	$V_F = 0, f = 1\text{ MHz}$
Thermal Resistance	$R\theta_{\text{J-pin}}$		160		$^\circ\text{C/W}$	Junction-to-Cathode
Luminous Efficacy ^[3]	η_v		145		lm/W	

Notes:

- $\theta_{1/2}$ is the off-axis angle where the luminous intensity is half the on-axis value.
- The dominant wavelength, λ_d , is derived from the CIE Chromaticity Diagram and represents the color of the device.
- The radiant intensity, I_e , in watts per steradian, may be found from the equation $I_e = I_v / \eta_v$, where I_v is the luminous intensity in candelas and η_v is luminous efficacy in lumens/watt.

Orange HSMD-TX00

Parameter	Symbol	Min.	Typ.	Max.	Units	Test Conditions
Luminous Intensity	I_v	1.5	5.0		mcd	$I_F = 10 \text{ mA}$
Forward Voltage	V_F		1.9	2.5	V	$I_F = 10 \text{ mA}$
Reverse Breakdown Voltage	V_R	5.0	30.0		V	$I_R = 100 \text{ }\mu\text{A}$
Included Angle Between Half Intensity Points ^[1]	$2\theta^{1/2}$		120		deg.	
Peak Wavelength	λ_{PEAK}		600		nm	
Dominant Wavelength ^[2]	λ_d		602		nm	
Spectral Line Half Width	$\Delta\lambda_{1/2}$		40		nm	
Speed of Response	τ_s		260		ns	Time Constant, e^{-t/τ_s}
Capacitance	C		4		pF	$V_F = 0, f = 1 \text{ MHz}$
Thermal Resistance	$R\theta_{\text{J-pin}}$		160		$^{\circ}\text{C/W}$	Junction-to-Cathode
Luminous Efficacy ^[3]	η_v		380		lm/W	

Yellow HSMY-TX00

Parameter	Symbol	Min.	Typ.	Max.	Units	Test Conditions
Luminous Intensity	I_v	2.0	5.0		mcd	$I_F = 10 \text{ mA}$
Forward Voltage	V_F		2.0	2.5	V	$I_F = 10 \text{ mA}$
Reverse Breakdown Voltage	V_R	5.0	50.0		V	$I_R = 100 \text{ }\mu\text{A}$
Included Angle Between Half Intensity Points ^[1]	$2\theta^{1/2}$		120		deg.	
Peak Wavelength	λ_{PEAK}		583		nm	
Dominant Wavelength ^[2]	λ_d		585		nm	
Spectral Line Half Width	$\Delta\lambda_{1/2}$		36		nm	
Speed of Response	τ_s		90		ns	Time Constant, e^{-t/τ_s}
Capacitance	C		15		pF	$V_F = 0, f = 1 \text{ MHz}$
Thermal Resistance	$R\theta_{\text{J-pin}}$		160		$^{\circ}\text{C/W}$	Junction-to-Cathode
Luminous Efficacy ^[3]	η_v		500		lm/W	

Notes:

- $\theta^{1/2}$ is the off-axis angle where the luminous intensity is half the on-axis value.
- The dominant wavelength, λ_d , is derived from the CIE Chromaticity Diagram and represents the color of the device.
- The radiant intensity, I_e , in watts per steradian, may be found from the equation $I_e = I_v / \eta_v$, where I_v is the luminous intensity in candelas and η_v is luminous efficacy in lumens/watt.

High Performance Green HSMG-TX00

Parameter	Symbol	Min.	Typ.	Max.	Units	Test Conditions
Luminous Intensity	I_v	4.0	10.0		mcd	$I_F = 10 \text{ mA}$
Forward Voltage	V_F		2.0	2.5	V	$I_F = 10 \text{ mA}$
Reverse Breakdown Voltage	V_R	5.0	50.0		V	$I_R = 100 \text{ }\mu\text{A}$
Included Angle Between Half Intensity Points ^[1]	$2\theta_{1/2}$		120		deg.	
Peak Wavelength	λ_{PEAK}		570		nm	
Dominant Wavelength ^[2]	λ_d		572		nm	
Spectral Line Half Width	$\Delta\lambda_{1/2}$		28		nm	
Speed of Response	τ_s		500		ns	Time Constant, e^{-t/τ_s}
Capacitance	C		18		pF	$V_F = 0, f = 1 \text{ MHz}$
Thermal Resistance	$R\theta_{\text{J-pin}}$		160		$^{\circ}\text{C/W}$	Junction-to-Cathode
Luminous Efficacy ^[3]	η_v		595		lm/W	

Notes:

- $\theta_{1/2}$ is the off-axis angle where the luminous intensity is half the on-axis value.
- The dominant wavelength, λ_d , is derived from the CIE Chromaticity Diagram and represents the color of the device.
- The radiant intensity, I_e , in watts per steradian, may be found from the equation $I_e = I_v / \eta_v$, where I_v is the luminous intensity in candelas and η_v is luminous efficacy in lumens/watt.

Emerald Green HSME-TX00

Parameter	Symbol	Min.	Typ.	Max.	Units	Test Conditions
Luminous Intensity	I_v	1.0	1.5		mcd	$I_F = 10 \text{ mA}$
Forward Voltage	V_F		2.2	2.27	V	$I_F = 10 \text{ mA}$
Reverse Breakdown Voltage	V_R	5.0	50.0		V	$I_R = 100 \text{ }\mu\text{A}$
Included Angle Between Half Intensity Points ^[1]	$2\theta_{1/2}$		120		deg.	
Peak Wavelength	λ_{PEAK}		558		nm	
Dominant Wavelength ^[2]	λ_d		560		nm	
Spectral Line Half Width	$\Delta\lambda_{1/2}$		28		nm	
Speed of Response	τ_s		500		ns	Time Constant, e^{-t/τ_s}
Capacitance	C		52		pF	$V_F = 0, f = 1 \text{ MHz}$
Thermal Resistance	$R\theta_{\text{J-pin}}$		120		$^{\circ}\text{C/W}$	Junction-to-Cathode
Luminous Efficacy ^[3]	η_v		680		lm/W	

Notes:

- $\theta_{1/2}$ is the off-axis angle where the luminous intensity is half the on-axis value.
- The dominant wavelength, λ_d , is derived from the CIE Chromaticity Diagram and represents the color of the device.
- The radiant intensity, I_e , in watts per steradian, may be found from the equation $I_e = I_v / \eta_v$, where I_v is the luminous intensity in candelas and η_v is luminous efficacy in lumens/watt.
- Refer to Application Note 1061 for information comparing high performance green with emerald green light output degradation.

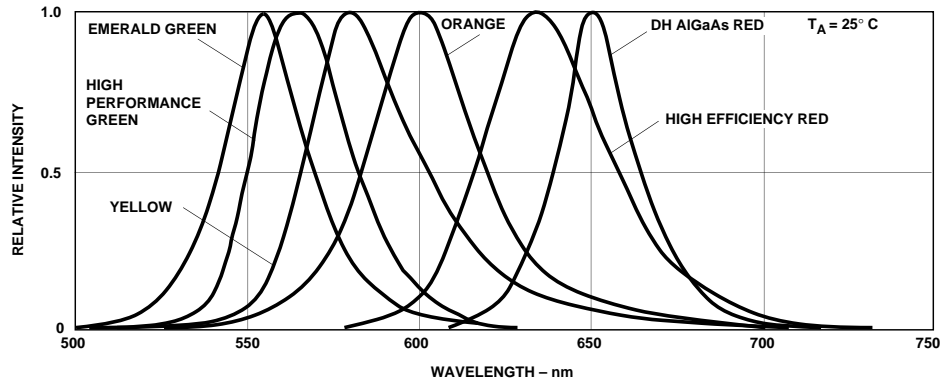

Figure 1. Relative Intensity vs. Wavelength.

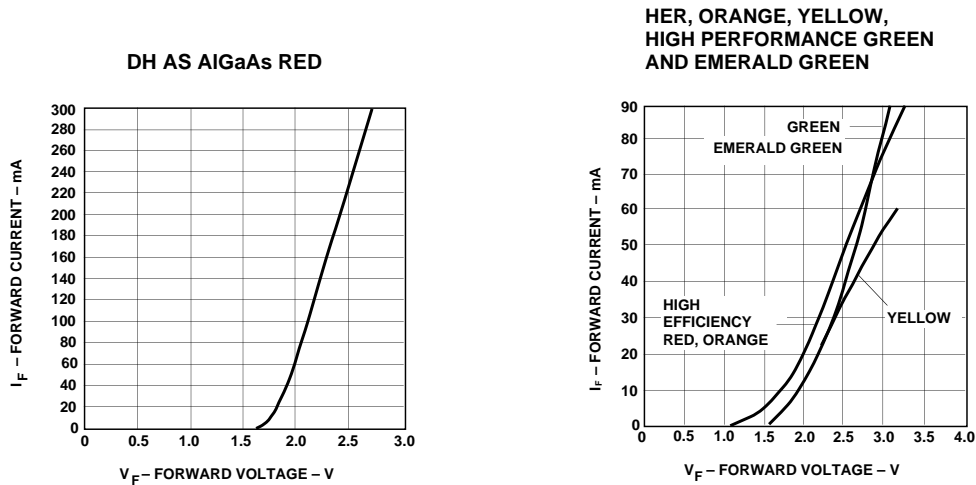

Figure 2. Forward Current vs. Forward Voltage.

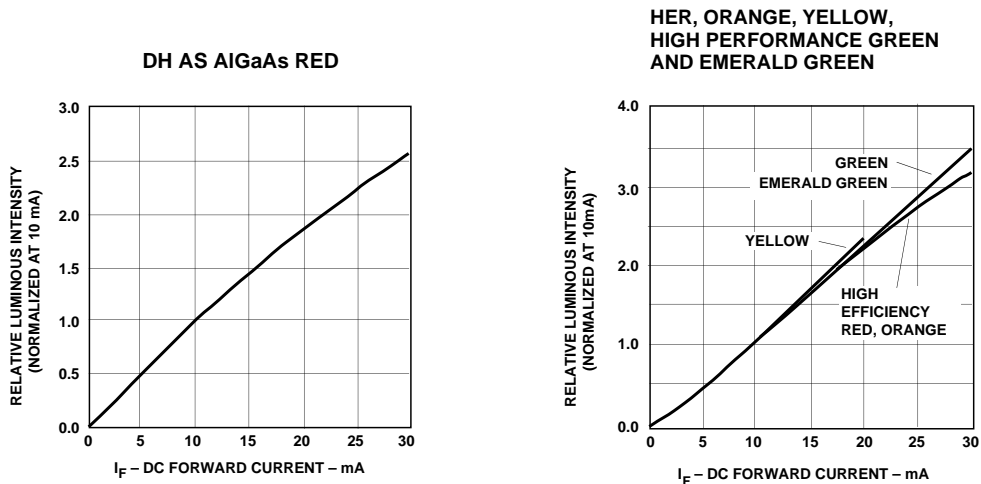

Figure 3. Relative Luminous Intensity vs. Forward Current.

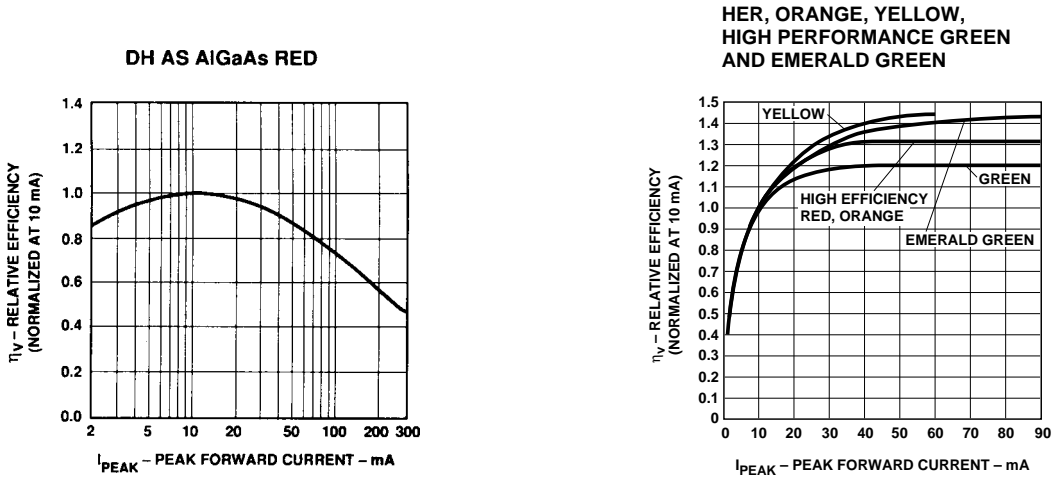

Figure 4. Relative Efficiency (Luminous Intensity per Unit Current) vs. Peak Current.

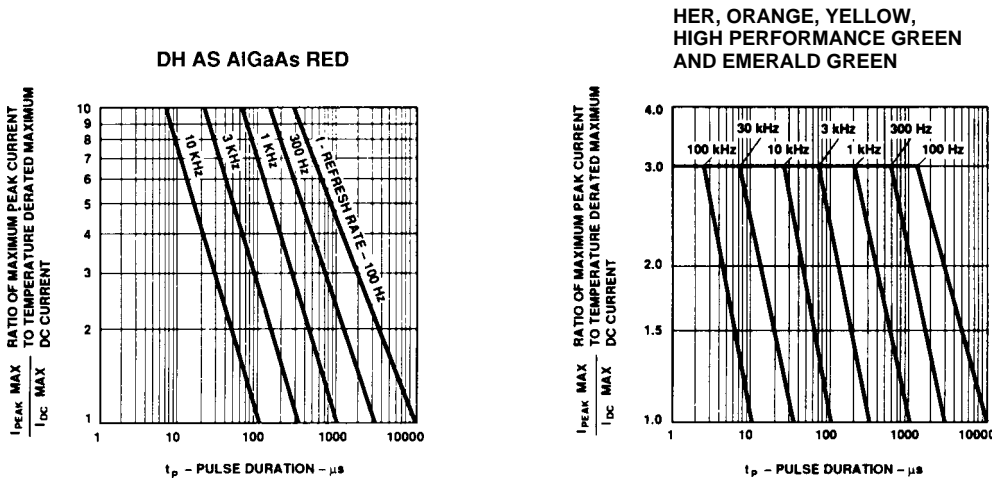

Figure 5. Maximum Tolerable Peak Current vs. Pulse Duration ($I_{DC MAX}$ per MAX Ratings).

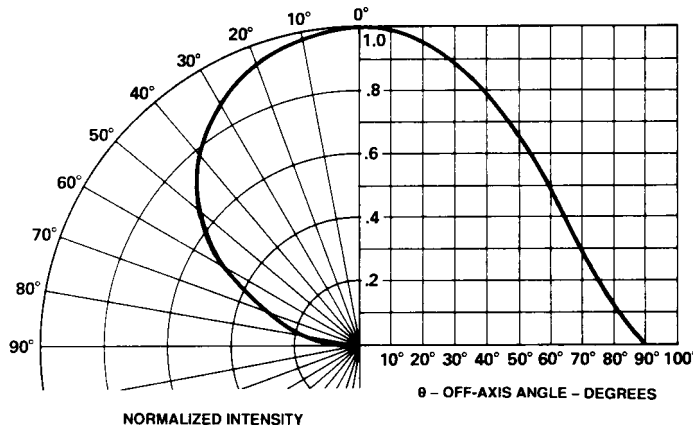

Figure 6. Relative Intensity vs. Angular Displacement.