

SSC050

I²C Backplane Controller

Product Brief



Overview

The SSC050 I²C Backplane Controller is a CMOS integrated circuit, which enables a system designer to reduce system cost by integrating all of the digital logic typically required in a storage enclosure. The SSC050 may be used in any embedded control application including parallel SCSI, Fibre Channel or any other application where the monitoring and control of a large number of digital I/O signals is required. Programming the SSC050 is easy through a convenient programming model, which reduces the overall duration of the design-in cycle. Data is read and written to the device over an addressable (3-bit) I²C serial interface, allowing multiple SSC050 devices on a single two-wire bus.

Device Features

- I²C Serial Interface (DC to 400Khz)
- 4 Fan Speed Monitor Inputs
- 40 Programmable, Bi-directional I/O Pins
- Flexible FC-AL Port Bypass Control Logic
- Bit Programmable Interrupt Control
- Seven LED Flash Rates
- 64 PQFP Package

I²C Serial Interface

The SSC050 uses an I²C serial interface to communicate with embedded controllers such as Vitesse's SSC100/200 and VSC205/210. The slave interface on the SSC050 uses a three-bit (A2:0) addressing scheme for identification on the serial interface. The ASEL pin determines the four-bit device type identifier. Up to sixteen, SSC050 or VCS055 devices may reside on a single I²C serial interface.

I/O Pins

The SSC050 has forty bi-directional I/O pins. The functionality of these pins is configurable via programming of the SSC050. All I/O pins have a 12mA drive strength and support 3.3V TTL. To enable the designer to configure and program the SSC050, the forty I/Os are arranged in registers of eight pins. Certain groups of pins have additional functionality beyond simple input or output to support the integrated fan speed sensors and FC-AL port bypass control.

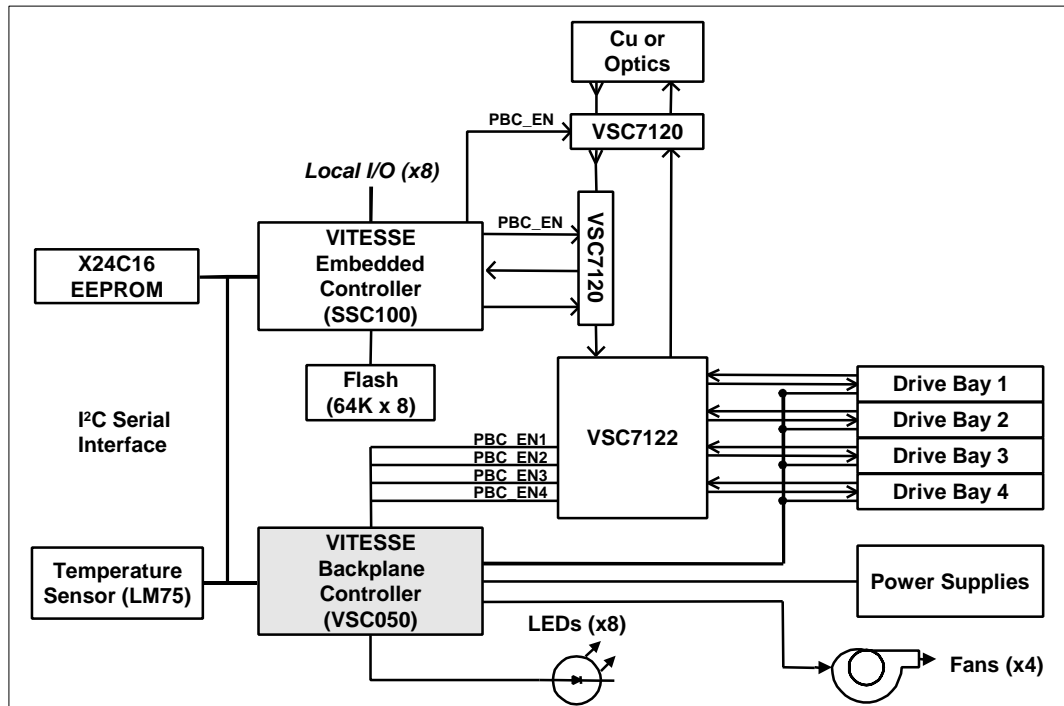

Application for a Single Loop, Single Controller with Four Drives

LED Flash Rate Control

The built-in flexibility of the SSC050 allows all forty of the I/O pins to drive LEDs through a pull-up resistor. Each pin is independently programmed to flash an LED at one of seven predefined flash rates.

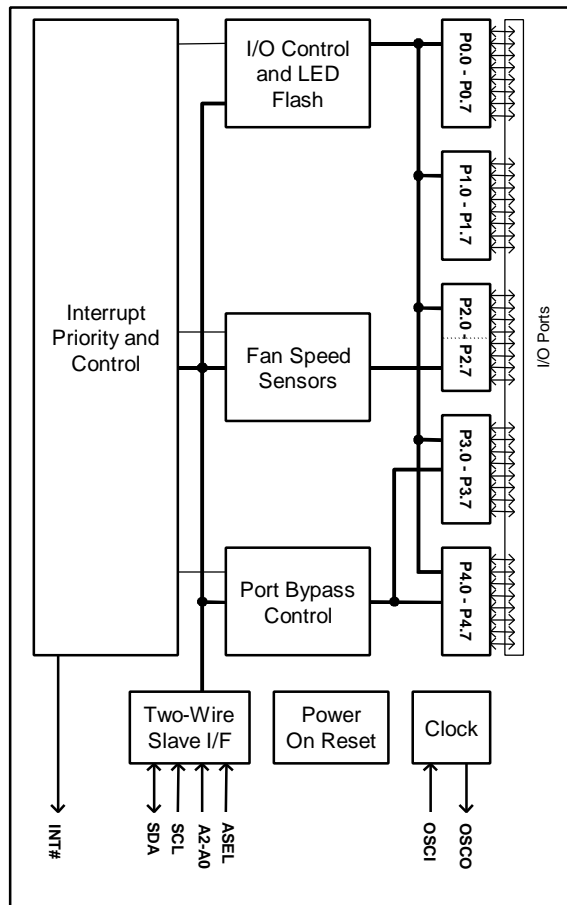

SSC050 Block Diagram

Fan Speed Sensors

The SSC050 includes four pins (P2.4 to P2.7), which may be configured as fan speed sensors. This feature enables the designer to provide high value monitoring features at significantly reduced costs. Embedded controllers may access the SSC050 to determine the rotational speed (RPM) of fans attached to each of the four inputs. The SSC050 may also be programmed to signal an interrupt if any one of the speed sensors fall below the designer's predefined level.

FC-AL Port Bypass Control

Up to sixteen of the forty I/Os may be configured to monitor and manage FC-AL port bypass control devices. Eight pairs of I/Os include special logic to monitor Enable Bypass signals, which may be generated by FC-AL disk drives, and control Port Bypass Control Enable (PBC_Enx) signals on port bypass devices such as Vitesse's VSC7122.

The unique functionality of the SSC050 provides the system designer with additional flexibility and control over the port bypass function in a FC-AL enclosure. This allows system designers to differentiate and add value by controlling when and how a drive is removed or inserted into a FC-AL enclosure.

This feature may also be used for non-FC-AL applications. It is useful wherever system designers require flexible monitoring and control of backplane signals.

Interrupt Support

There are up to forty interrupt sources within the SSC050. I/O pin signal transitions, fan speed sensor threshold levels and transitions on port bypass inputs may be configured to generate interrupts. Advanced interrupt priority and management logic provides the system designer with maximum flexibility and a simple and convenient programming method for handling interrupts.

Related Documents

- VSC050 Data Manual
- SSC100/200/VSC205/210 Data Manual
- Any SDK Specification

For More Information: www.vitesse.com

email: proinfo@vitesse.com

TEL: 1-800-VITESSE FAX: 805/987-5896

Vitesse Semiconductor Corporation reserves the right to make changes in its products, specifications or other information at any time without prior notice. Therefore the reader is cautioned to confirm that this datasheet is current prior to placing any orders. The company assumes no responsibility for any circuitry described other than circuitry entirely embodied in a Vitesse product. (Version 1.0)

© 2000 Vitesse Semiconductor Corporation, All Rights Reserved.