

---

# Low Cost Gigabit Rate Transmit/Receive Chip Set

## Technical Data

---

### HDMP-1012 Transmitter HDMP-1014 Receiver

---

#### Features

- **Transparent, Extended Ribbon Cable Replacement**
- **Implemented in a Low Cost Aluminum M-Quad 80 Package**
- **High-Speed Serial Rate** 150-1500 MBaud
- **Standard 100K ECL Interface**  
16, 17, 20, or 21 Bits Wide
- **Reliable Monolithic Silicon Bipolar Implementation**
- **On-chip Phase-Locked Loops**
  - Transmit Clock Generation
  - Receive Clock Extraction

#### Applications

- **Backplane/Bus Extender**
- **Video, Image Acquisition**
- **Point to Point Data Links**
- **Implement SCI-FI Standard**
- **Implement Serial HIPPI Specification**

#### Description

The HDMP-1012 transmitter and the HDMP-1014 receiver are used to build a high speed data link for point to point communication. The monolithic silicon bipolar transmitter chip and receiver chip are each provided in a standard aluminum M-Quad 80 package.

From the user's viewpoint, these products can be thought of as providing a "virtual ribbon cable" interface for the transmission of data. Parallel data loaded into the Tx (transmitter) chip is delivered to the Rx (receiver) chip over a serial channel, which can be either a coaxial copper cable or optical link.

The chip set hides from the user all the complexity of encoding, multiplexing, clock extraction, demultiplexing and decoding. Unlike other links, the phase-locked-loop clock extraction circuit also transparently provides for frame synchronization - the user is not troubled with the periodic insertion of frame synchronization words. In addition, the dc balance of the line code is automatically maintained by the chip set. Thus, the user can transmit arbitrary data without restriction. The Rx chip also includes a state-machine

controller (SMC) that provides a startup handshake protocol for the duplex link configuration.

The serial data rate of the T/R link is selectable in four ranges (see tables on page 5), and extends from 120 Mbits/s up to 1.25 Gbits/s. The parallel data interface is 16 or 20 bit single-ended ECL, pin selectable. A flag bit is available and can be used as an extra 17th or 21st bit under the user's control. The flag bit can also be used as an even or odd frame indicator for dual-frame transmission. If not used, the link performs expanded error detection.

The serial link is synchronous, and both frame synchronization

and bit synchronization are maintained. When data is not available to send, the link maintains synchronization by transmitting fill frames. Two (training) fill frames are reserved for handshaking during link startup.

User control space is also supported. If Control Available is asserted at the Tx chip, the least significant 14 or 18 bits of the data are sent and the Rx Control Available line will indicate the data as a Control Word.

It is the intention of this data sheet to provide the design engineer all of the information regarding the HDMP-1012/1014 chipset necessary to design this product into their application. To assist you in using this data sheet, the following Table of Contents is provided.

## Table of Contents

Topic	Page
Typical Applications .....	575
Setting the Operating Rate .....	576
Transmitter Block Diagram .....	578
Receiver Block Diagram .....	580
Transmitter Timing Characteristics .....	582
Receiver Timing Characteristics .....	583
DC Electrical Specifications .....	584
AC Electrical Specifications .....	584
Typical Lock-Up Times .....	584
Absolute Maximum Ratings .....	585
Thermal Characteristics .....	585
I/O Type Definitions .....	585
Pin-Out Diagrams .....	586
Transmitter Pin Definitions .....	587
Receiver Pin Definitions .....	591
Mechanical Dimensions and Surface Mount Assembly Instructions .....	595
<b>Appendix I: Additional Internal</b>	
<b>Architecture Information</b> .....	
Line Code Description .....	596
Data Frame Codes .....	596
Control Frame Codes .....	597
Fill Frame Codes .....	598
Tx Operation Principles .....	599
Tx Encoding .....	599
Tx Phase Locked Loop .....	600
Rx Operation Principles .....	601
Rx Encoding .....	601
HDMP-1014 (Rx) Phase Locked Loop .....	601
HDMP-1014 (Rx) Decoding .....	602
HDMP-1014 (Rx) Link Control State Machine Operation Principle .....	603
The State Machine Handshake Protocol .....	603
<b>Appendix II: Link Configuration Examples</b> .....	
Duplex/Simplex Configurations .....	605
Full Duplex .....	605
Simplex Method I: Simplex with Low Speed Return Path .....	606
Simplex Method II: Simplex with Periodic Sync Pulse .....	607
Simplex Method III: Simplex with External Reference Oscillator .....	607
Data Interface for Single/Double Frame Mode .....	608
Single Frame Mode (MDFSEL=0) .....	608
Double Frame Mode (MDFSEL=1) .....	609
Supply Bypassing and Integrator Capacitor .....	610
Integrating Capacitor .....	610
Power Supply Bypassing and Grounding .....	610
Electrical Connections .....	611
I-ECL and O-ECL .....	611
High Speed Interface: I-H50 & O-BLL .....	612
TTL and Positive 5 V Operation .....	613
Mode Options .....	614

## Typical Applications

The HDMP-1012/1014 chipset was designed for ease of use and flexibility. This allows the customer to tailor the use of this product, through the configuration of the link, based on their specific system requirements and application needs. Typical applications range from backplane and bus extension to digital video transmission.

Low latency bus extension of a 16 or 20 bit wide data bus may be achieved using the standard duplex configuration (see Figure 1d). In full duplex, the HDMP-1012/1014 chipset handles all of the issues of link startup, maintenance, and simple error detection.

If the bus width is 32 or 40 bits wide, the HDMP-1012/1014 chipset is capable of sending the large data frame as two separate frame segments, as shown in Figure 1b. In this mode, called Double Frame Mode, the FLAG bit is used by the transmitter and receiver to indicate the first or second frame segment. The HDMP-1012/1014 chipset in Double Frame Mode may also be configured in full duplex to achieve a 32/40 bit wide bus extension.

For digital video transmission, simplex links are more common. The HDMP-1012/1014 chipset can transmit 16 to 21 bits of parallel data in standard or broadcast simplex mode. Additionally, 32 to 40 bit wide data can be transmitted over a single line (in Double Frame Mode) or two parallel lines, as in Figure 1c.

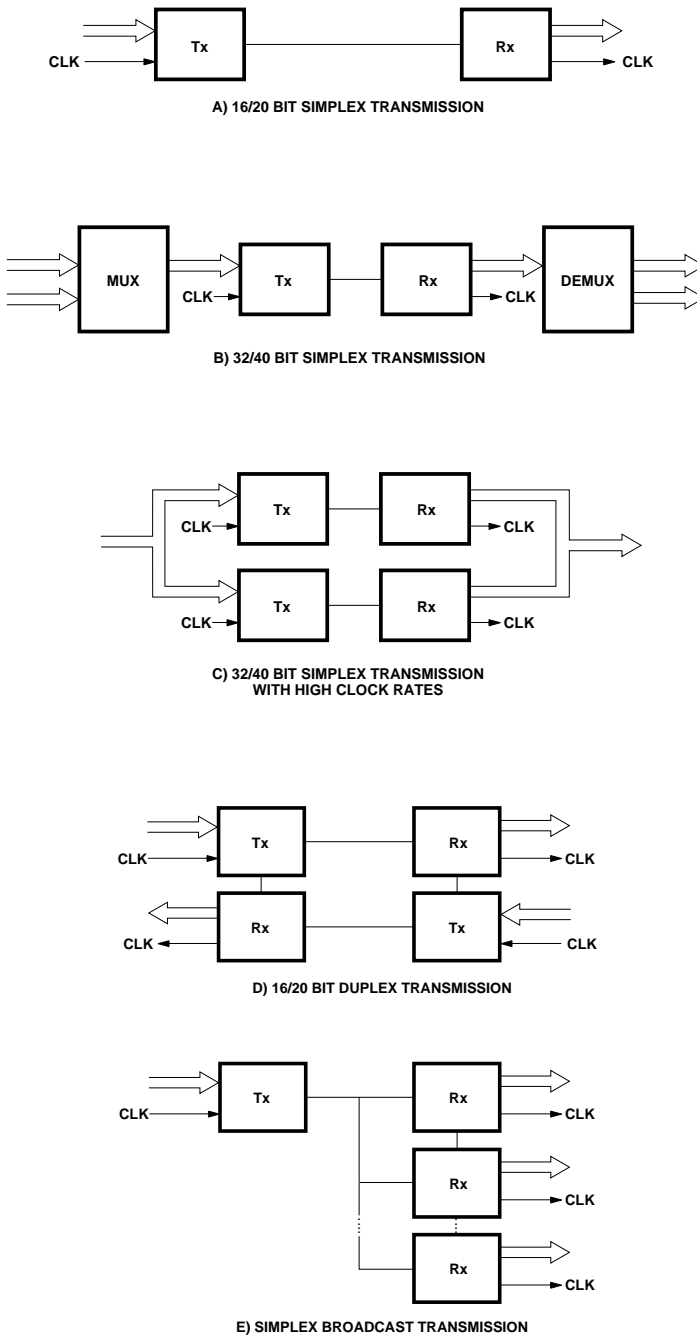

Figure 1. Various Configurations Using the HDMP-1012/1014.

For timing diagrams for the standard configurations, see the Appendix section entitled *Link Configuration Examples*.

The HDMP-1012/1014 chipset can support serial transmission rates from 150 MBd to 1.5 GBd for each of these configurations. The chipset requires the user to input the link data rate by asserting DIV1 and DIV0 accordingly. To determine the DIV1/DIV0 setting necessary for each application, refer to the section: *Setting the Operating Data Rate Range* on the next page.

### Setting the Operating Data Rate Range

The HDMP-1012/1014 chipset can operate from 150 MBaud to 1500 MBaud. It is divided into four operating data ranges with each range selected by setting DIV1 and DIV0 as shown in the tables below.

The purpose of following example is to help in understanding and using these tables. This specific example uses the table in figure 3 entitled "Typical 20-bit Mode Data Rates".

It is desired to transmit a 20 bit parallel word operating at 55 MHz (55 MWord/sec). Both the Tx and Rx must be set to a range that this word rate falls in-between.

According to table entitled "Typical Operating Rates for 20 Bit Mode" on the next page, a setting of DIV1/DIV0 = logic '0/0' allows a parallel input word rate of 32.9 to 62.5 MHz. This setting easily accommodates the required 55 MHz word rate. The user serial data rate can be calculated as:

$$\begin{aligned} \text{Serial Data Rate} &= \left(\frac{20 \text{ bit}}{\text{word}}\right) \left(\frac{55 \text{ Mw}}{\text{sec}}\right) \\ &= 1100 \text{ MBits/sec} \end{aligned}$$

The baud rate includes an additional 4 bits that G-LINK transmits for link control and error detection. The serial baud rate is calculated as:

$$\begin{aligned} \text{Serial Baud Rate} &= \left(\frac{24 \text{ bits}}{\text{word}}\right) \left(\frac{55 \text{ Mw}}{\text{sec}}\right) \\ &= 1320 \text{ MBaud} \end{aligned}$$

The 55 MHz example is one in which the parallel word rate provides only one possible DIV1/DIV0 setting.

Some applications may have a parallel word rate that seems to fit two ranges. As an example, a 35 MHz (35 MWord/s) parallel data rate fall within two ranges (DIV0/DIV1 = 0/0 and DIV0/DIV1 = 0/1) in 20 Bit Mode. Per the table, a setting of DIV1/DIV0 = 0/1 gives an upper rate of 53.3 MHz, while a setting of DIV1/DIV0 = 0/0 gives a lower rate of 32.9 MHz. These transition data rates are stated in the tables as typical values and may vary between individual parts. Each transmitter/receiver has continuous band cover across its entire 150 to 1500 MBaud range and has overlap between ranges. Each transmitter/receiver will permit a 35 MHz parallel data rate, but it is suggested that DIV0 be a jumper that can be set either to logic '1' (ground) or logic '0' (open). This allows the design to accommodate both ranges for maximum flexibility. This technique is recommended whenever operating near the maximum and minimum of two word rate ranges. The above information also applies to the HDMP-1012/1014 chipset when operating in 16 bit mode.

## HDMP-1012 (Tx), HDMP-1014 (Rx)

### Typical Operating Rates For 16 Bit Mode<sup>[1]</sup>

T<sub>c</sub> = 0°C to +85°C, V<sub>EE</sub> = -4.5 V to -5.5 V

DIV1	DIV0	Parallel Word Rate (Mword/sec) Range		Serial Data Rate (Mbit/sec) Range		Serial Baud Rate (MBaud) Range	
0	0	42	75.0 (max)	672	1200.0 (max)	840	1500.0 (max)
0	1	21	51	336	808	420	1010
1	0	11	25	168	404	210	505
1	1	7.5 (min)	13	120.0 (min)	202	150.0 (min)	253

#### Notes:

1. Extended operating rates to 1800 MBaud/sec (typ) are possible for T<sub>c</sub> = 0°C to +60°C.
2. All values are typical over temperature and process, unless otherwise noted by (*min*) or (*max*).
3. Typical Serial Baud Rates for DIV1/DIV0 = 0/0 are up to 1800 MBd.
4. All values in this table are expected for a BER less than 10<sup>-14</sup>. This estimation is based on the maximum data rate characterization, which was performed at a serial data rate of 2000 Mbits/s for a BER less than 10<sup>-11</sup>. Production units are 100% screened for less than BER = 10<sup>-7</sup>.

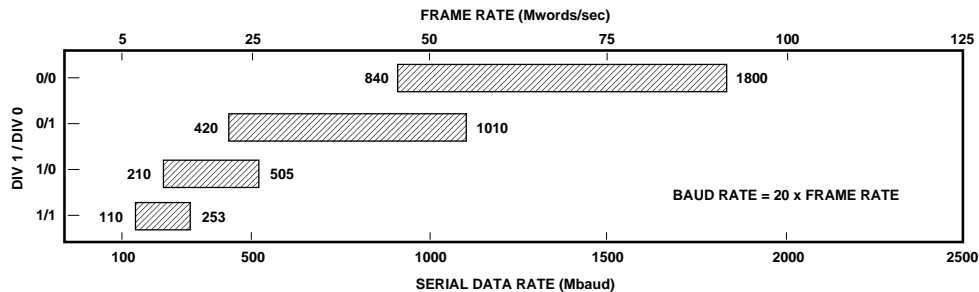

Figure 2: Typical 16-bit Mode Data Rates.

## HDMP-1012 (Tx), HDMP-1014 (Rx)

### Typical Operating Rates For 20 Bit Mode<sup>[1]</sup>

T<sub>c</sub> = 0°C to +85°C, V<sub>EE</sub> = -4.5 V to -5.5 V

DIV1	DIV0	Parallel Word Rate (Mword/sec) Range		Serial Data Rate (Mbit/sec) Range		Serial Baud Rate (MBaud/Sec) Range	
0	0	35	62.5 (max)	700	1250.0 (max)	840	1500 (max)
0	1	18	42	350	842	420	1010
1	0	9	21	175	421	210	505
1	1	6.3 (min)	10.5	125.0 (min)	211	150 (min)	253

#### Notes:

1. Extended operating rates to 1800 MBaud/sec are possible for T<sub>c</sub> = 0°C to +60°C.
2. All values are typical over temperature and process, unless otherwise noted by (*min*) or (*max*).
3. Typical Serial Baud Rates for DIV1/DIV0 = 0/0 are up to 1800 MBd.
4. All values in this table are expected for a BER less than 10<sup>-14</sup>. This estimation is based on the maximum data rate characterization, which was performed at a serial data rate of 2000 Mbits/s for a BER less than 10<sup>-11</sup>. Production units are 100% screened for less than BER = 10<sup>-7</sup>.

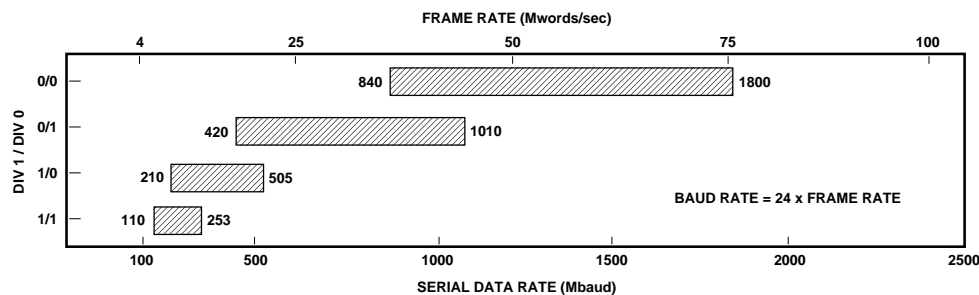

Figure 3: Typical 20-Bit Mode Data Rates.

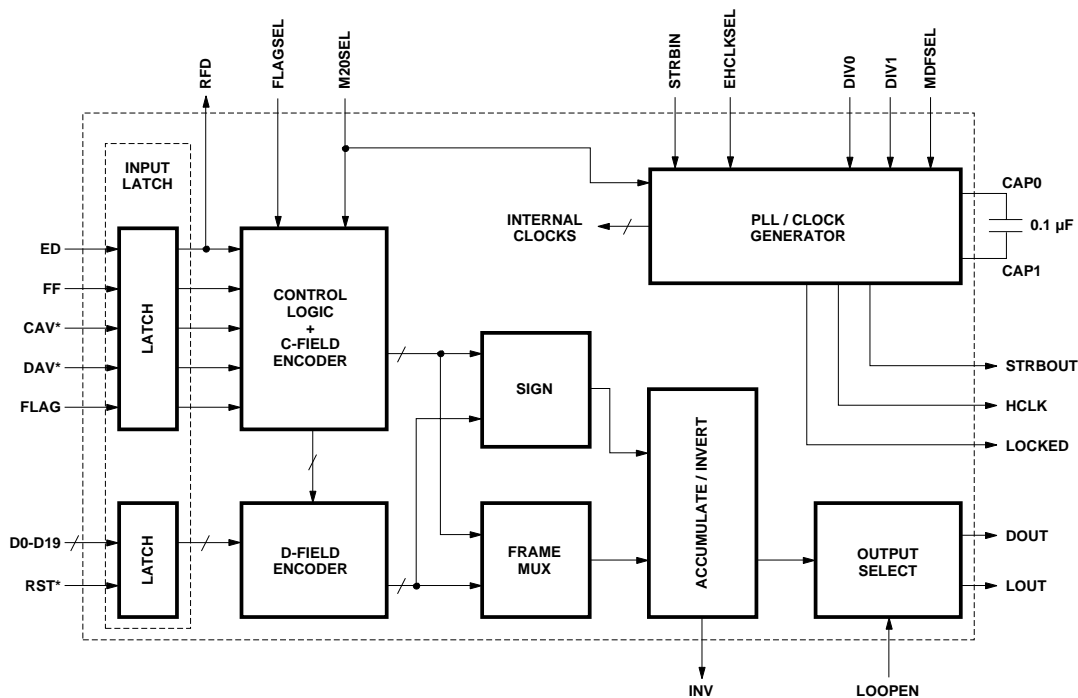

Figure 4. HDMP-1012 Transmitter Block Diagram.

## HDMP-1012 Tx Block Diagram

The HDMP-1012 was designed to accept 16 or 20 bit wide parallel data and transmit it over a high speed serial line, while minimizing the user's necessary interface to the high speed circuitry. In order to accomplish this task, the HDMP-1012 performs the following functions:

- Parallel Word Input
- High Speed Clock Multiplication
- Frame Encoding
- Parallel to Serial Multiplexing

### PLL/Clock Generator

The Phase Lock-loop and Clock Generator are responsible for generating all internal clocks needed by the transmitter to perform its functions. These clocks are based on a supplied frame clock (STRBIN) and control signals (M20SEL, MDFSEL, EHCLKSEL, DIV1, DIV0). In normal operation (MDFSEL=0), STRBIN is expected to be the

incoming frame clock. The PLL/ Clock Generator locks on to this incoming rate and multiplies the clock up to the needed high speed serial clock. Based on M20SEL, which determines whether the incoming data frame is 16 or 20 bits wide, the PLL/Clock Generator multiplies the frame rate clock by 20 or 24 respectively (data bits + 4 control bits). DIV1/DIV0 are set to inform the transmitter of the frequency range of the incoming data frames. The internal frame rate clock is accessible through STRBOUT and the high speed serial clock is accessible through HCLK.

When MDFSEL is set high, the transmitter is in Double Frame Mode. Using this option, the user may send a 32 or 40 bit wide data frame in two segments while supplying the original 32 or 40 bit frame clock at STRBIN. Doubling of the frame rate is performed by

the transmitter. The clock generator section performs the clock multiplication to the necessary serial clock rate.

By setting EHCLKSEL high, the user may provide an external high speed serial clock at STRBIN. This clock is used directly by the high speed serial circuitry to output the serial data.

### Control Logic and C-Field Encoder

The Control Logic is responsible for determining what information is serially sent to the output. If CAV\* is low, it sends the data at D0..D8 and D9..D17 as control word information. If CAV\* is high and DAV\* is low, it sends parallel word data at the data inputs. If neither CAV\* nor DAV\* is set low, then the transmitter assumes the link is not being used. In this state, the control logic triggers the Data Encoder to send Fill Frames to maintain the link DC balance and allow the receiver to

maintain frequency and phase lock. The type of fill frames sent (FF0 or FF1) is determined by the FF input. In a duplex system, FF is normally connected to the Rx's STAT1 pin.

The C-Field Encoder, based on the inputs at DAV\*, CAV\*, FLAGSEL, and FLAG, supplies four encoded bits to the frame mux. This encoded data contains the master transition (which the receiver uses for frequency locking), as well as information regarding the data type: control, data, or fill frame. In order for the FLAG bit to be used as an additional data bit, FLAGSEL must be set high for both the Tx and the Rx.

#### **D-Field Encoder**

The D-Field Encoder provides the remaining parallel word data to the frame mux. Based on control signals from the Control Logic, the D-Field Encoder either outputs the parallel information at

its data inputs (D0..D19) or the designated Fill Frame. RST\*, when set low, resets the internal chip registers.

#### **Frame Mux**

The Frame Mux accepts the output from the C-Field and D-Field Encoders. The four control bits are attached to the data bits, either 16 or 20 data bits based on the M20SEL input. This parallel information, now either 20 or 24 bits wide, is multiplexed to a serial line based on the internal high speed serial clock.

#### **SIGN**

The sign circuitry determines the cumulative sign of the outgoing data frame, containing the data and control bits. This is used by the accumulator/inverter to maintain DC balance for the transmission line.

#### **Accumulator/Invert**

The Accumulator/Invert block is responsible for maintaining the

DC balance of the serial line. It determines, based on history and the sign of the current data frame, whether or not the current frame should be inverted to bring the line closer to the desired 50% duty cycle. INV is set high when the data frame is inverted.

#### **Output Select**

In normal operation, the serial data stream is placed at DOUT. By asserting LOOPEN, the user may also direct the serial data stream to LOUT, which may be used for loopback testing. When LOOPEN is not asserted, LOUT is disabled to reduce power consumption.

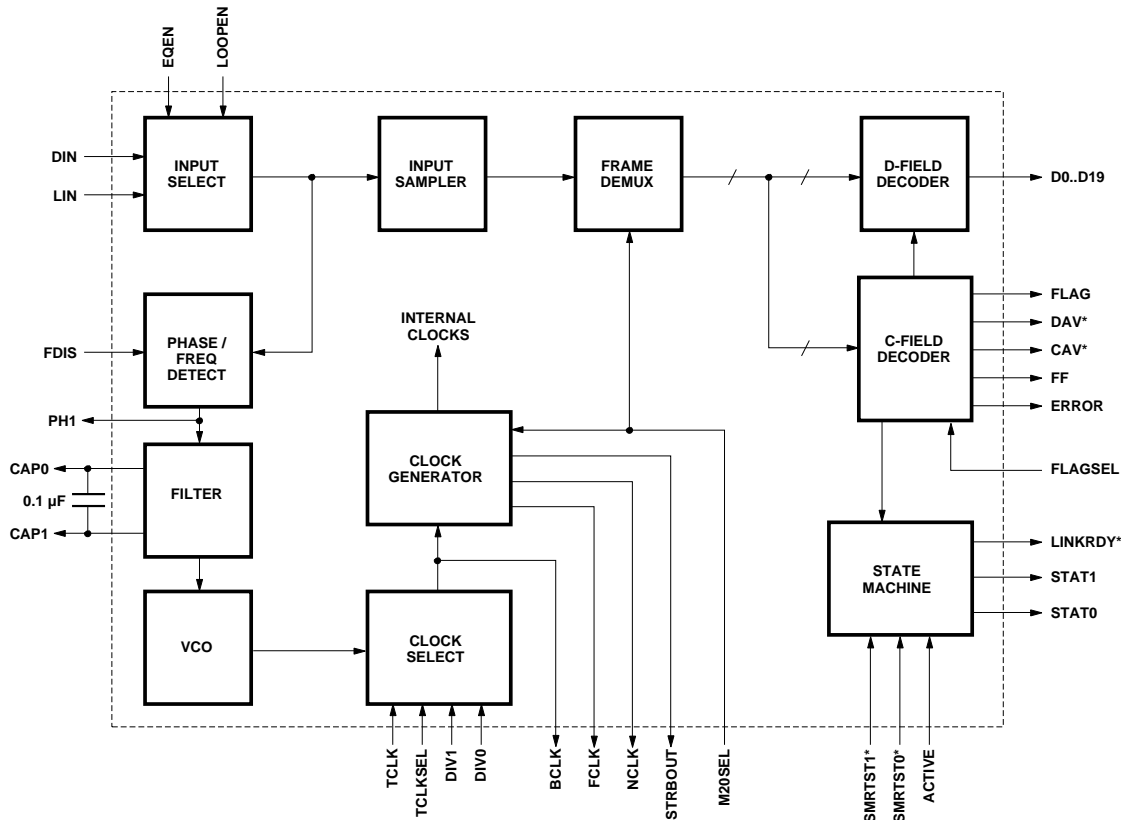

Figure 5. HDMP-1014 Receiver Block Diagram.

## HDMP-1014 Rx Block Diagram

The HDMP-1014 receiver was designed to convert a serial data signal sent from the HDMP-1012 into either 16,17, 20 or 21 bit wide parallel data. In doing this, it performs the functions of

- Clock Recovery
- Data Recovery
- Demultiplexing
- Frame Decoding
- Frame Synchronization
- Frame Error Detection
- Link State Control

### Input Select

The input select block determines which input line is used. In normal operation (LOOPEN=0), DIN is accepted as the input signal. For improved distance and BER using coax cable, an input equalizer may be used by asserting EQEN. By setting

LOOPEN high, the receiver accepts LIN as the input signal. This feature allows for loop back testing exclusive of the transmission medium.

### Phase/Freq Detect

This block compares either the phase or the frequency of the incoming signal to the internal serial clock, generated from the Clock Select block. The frequency detect disable pin (FDIS) is set high to disable the frequency detector and enable the phase detector. See *HDMP-1014 (Rx) Phase Locked Loop* for more details. The output of this block, PH1, is used by the filter to determine the control signal for the VCO.

### Filter

This is a loop filter that accepts the PH1 output from the Phase/Freq Detector and converts it into

a control signal for the VCO. This control signal tells the VCO whether to increase or decrease its frequency. The Filter uses the PH1 input to determine a proportional signal and an integral signal. The proportional signal determines whether the VCO should increase or decrease its frequency. The integral signal filters out the high frequency PH1 signal and stores a historical PH1 output level. The two signals combined determine the magnitude of frequency change of the VCO.

### VCO

This is the Voltage Controlled Oscillator that is controlled by the output of the Filter. It outputs a high speed digital signal to the Clock Select.



### **Clock Select**

The Clock Select accepts the high speed digital signal from the VCO and outputs an internal high speed serial clock. The VCO frequency is divided, based on the DIV1/DIV0 inputs, to the input signal's frequency range. The Clock Select output, accessible through BCLK, is an internal serial clock. It is phase and frequency locked to the incoming signal. This internal serial clock is used by the Input Sampler to sample the data. It is also used by the Clock Generator to generate the recovered frame rate clock.

By setting TCLKSEL high, the user may input an external high speed serial clock at TCLK. The Clock Select accepts this signal and directly outputs it as the internal serial clock.

### **Clock Generator**

The Clock Generator accepts the serial clock generated from the Clock Select and generates the frame rate clock, based on the setting of M20SEL. If M20SEL is asserted, the incoming encoded data frame is expected to be 24 bits wide (20 data bits and 4 control bits). The master transition in the control section of encoded data stream is expected every 24 bits, and used to ensure proper frame synchronization of the output frame clock, STRBOUT.

### **Input Sampler**

The serial input signal is converted into a serial bit stream, using the extracted internal serial clock from the Clock Select. This output is sent to the frame demux.

### **Frame Demux**

The Frame Demux demultiplexes the serial bit stream from the Input Sampler into a 20 or 24 bit wide parallel data word, based on the setting of M20SEL. The most significant 4 bits are sent to the C-Field Decoder, while the remaining 16 or 20 bits are sent to the D-Field Decoder.

### **C-Field Decoder**

The C-Field Decoder accepts the control information from the Frame Demux and determines what kind of frame is being received and whether or not it has to be inverted. The control bits are sent to the State Machine for error checking. The decoded information is sent to the D-Field Decoder. CAV\* is set low if the incoming frame is control data. DAV\* is set low if the information is data. If neither DAV\* nor CAV\* is set low, then the incoming frame is expected to be a fill frame. If FLAGSEL is asserted, the FLAG bit is restored to its original form. Otherwise, FLAG is used to differentiate between

the even and odd frames in Double Frame Mode. For more information about this, refer to *Double Frame Mode*.

### **D-Field Decoder**

The D-Field Decoder accepts the data field of the incoming data frame from the Frame Demux. Based on information from the C-Field Decoder, which determines what type of data is being received, the D-Field Decoder restores the parallel data back to its original form.

### **State Machine**

The State Machine is used in full duplex mode to perform the functions of link startup, link maintenance, and error checking. By setting the SMRST0\* and SMRST1\* low, the user, too, can reset the state machine and initiate link startup. SMRST1\* is usually connected to the transmitters LOCKED output. STAT1 and STAT0 denote the current state of link during startup. ACTIVE is an input normally driven by the STAT1 and STAT0 outputs. This ACTIVE input is retimed by STRBOUT and presented to the user as LINKRDY\*. LINKRDY\* is an active low output that indicates when the link is ready to transmit data. Refer to *The State Machine Handshake Protocol* section on page 600 for more details.

### HDMP-1012 (Tx) Timing

Figure 6 shows the Tx timing diagram. Under normal operations, the Tx PLL locks an internally generated clock to the incoming STRBIN. The incoming data, D0-D19, ED, FF, DAV\*, CAV\*, and FLAG, are latched by this internal clock. For MDFSEL=0, the input rate of STRBIN is expected to be the same as the parallel data rate. For MDFSEL=1, STRBIN should be 1/2 of the incoming parallel data

rate. The data must be valid before it's sampled for the set-up time ( $t_s$ ), and remain valid after it's sampled for the hold time ( $t_h$ ).

The set-up and hold times are referenced to STRBIN. This reference is the positive edge of STRBIN for MDFSEL=0, and is 1/2 the frame period from the positive or negative edge of STRBIN for MDFSEL=1. STRBOUT appears after this reference with a delay of  $T_{strb}$ . The rate of STRBOUT is always

the same as the word rate of the incoming data, independent of MDFSEL.

The start of a frame, D0, in the high speed serial output occurs after a delay of  $t_d$  after the rising edge of the STRBIN. The typical value of  $t_d$  may be calculated by using the following formula:

$$t_d = (2 * \text{serial bit duration} - 0.5 \text{ ns}) \text{ ns}$$

### HDMP-1012 (Tx) Timing Characteristics

$T_c = 0^\circ\text{C}$  to  $+85^\circ\text{C}$ ,  $V_{EE} = -4.5 \text{ V}$  to  $-5.5 \text{ V}$

Symbol	Parameter	Units	Min.	Typ.	Max.
$t_s$	Setup Time, for Rising Edge of STRBIN Relative to D0-D19, ED, FF, DAV*, CAV* and FLAG	nsec	6		
$t_h$	Hold Time, for Rising Edge of STRBIN Relative to D0-D19, ED, FF, DAV*, CAV* and FLAG	nsec	0		
$\Delta T_{strb}$	STRBOUT - STRBIN Delay	nsec		1.5	3

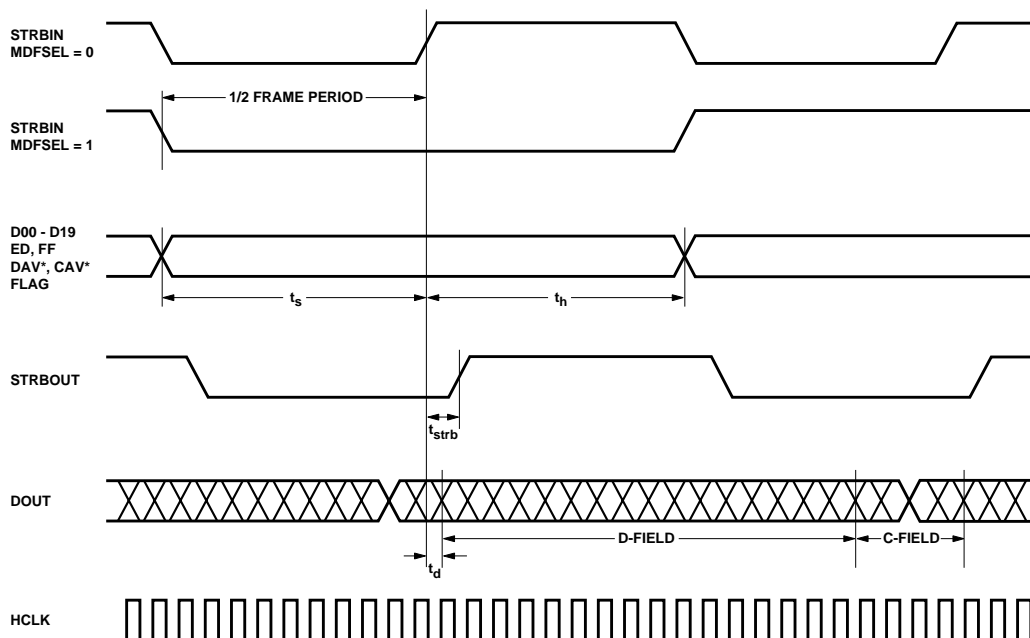

Figure 6. HDMP-1012 (Tx) Timing Diagram.

### HDMP-1014 (Rx) Timing

Figure 7 is the Rx timing diagram when the internal PLL is locked to the incoming serial data. The BCLK's frequency is the same as the input data rate. The size of the input data frame can be either 20 bits or 24 bits, depending on the setting of M20SEL. Independent of the frame size, STBROUT's falling edge is aligned

to the data frame's boundary, while the rising edge is in the center of the data frame.

The synchronous outputs, D00-D19, LINKRDY\*, DAV\*, CAV\*, FF, ERROR, and FLAG, are updated for every data frame, with a delay of  $t_{d1}$  after the falling edge of STRBOUT. There is a latency delay of two frames from

the input of the serial data frame to the update of the synchronous outputs.

The state machine outputs, STAT0, and STAT1, appear with the falling edge of STRBOUT after a delay of  $t_{d2}$ . These outputs are updated once every 128 frames.

### HDMP-1014 (Rx) Timing Characteristics

$T_c = 0^\circ\text{C}$  to  $+85^\circ\text{C}$

Symbol	Parameter	Units	Min.	Typ.	Max.
$t_{d1}$	Synchronous Output Delay	nsec		2.0	
$t_{d2}$	State Machine Output Delay	nsec		4.0	

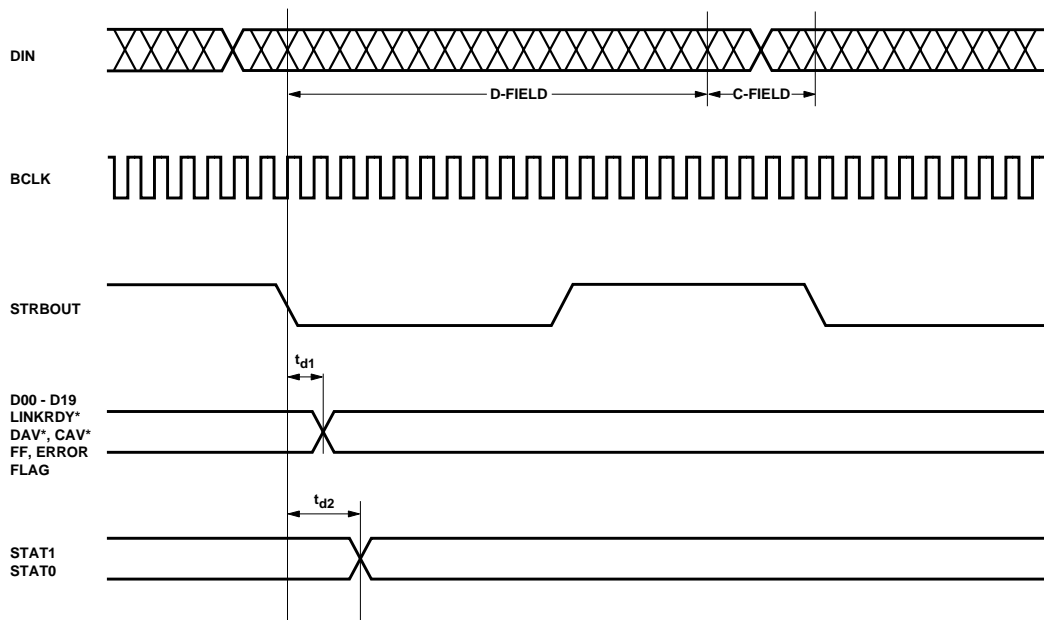

Figure 7. HDMP-1014 (Rx) Timing Diagram.

## HDMP-1012 (Tx), HDMP-1014 (Rx)

### DC Electrical Specifications

T<sub>c</sub> = 0°C to +85°C, GND = Ground, V<sub>EE</sub> = -4.5 V to -5.5 V

Symbol	Parameter	Units	Min.	Typ.	Max.
V <sub>IH,ECL</sub>	ECL Input High Voltage Level, Guaranteed high signal for all inputs	mV	-1150		
V <sub>IL,ECL</sub>	ECL Input Low Voltage Level, Guaranteed low signal for all inputs	mV			-1500
V <sub>OH,ECL</sub>	ECL Output High Voltage Level, Terminated with 300 Ω to -2.0 V	mV	-1050		
V <sub>OL,ECL</sub>	ECL Output Low Voltage Level, Terminated with 300 Ω to -2.0 V	mV			-1600
V <sub>IP,H50</sub>	H50 Input Peak-To-Peak Voltage	mV	200		
V <sub>DC,BLL</sub>	BLL Output Bias Voltage Level	mV		-900	
V <sub>OP,BLL</sub>	BLL Output Peak-To-Peak Voltage, Terminated with 50 Ω, ac coupled	mV		+600	
I <sub>EE,Tx</sub>	Transmitter V <sub>EE</sub> Supply Current, with HCLKSEL off T <sub>c</sub> = 50°C	mA		+403	
I <sub>EE,Rx</sub>	Receiver V <sub>EE</sub> Supply Current, T <sub>c</sub> = 50°C	mA		+512	

#### Note:

1. BLL outputs are measured with external 150 Ω pull-up resistors to ground. Refer to Figure 23 for additional information.

## HDMP-1012 (Tx), HDMP-1014 (Rx)

### AC Electrical Specifications

T<sub>c</sub> = 25°C

Symbol	Parameter	Units	Min.	Typ.	Max.
t <sub>r,ECL</sub>	ECL Rise Time, Terminated with 300 Ω to -2.0 V	nsec		1	
t <sub>f,ECL</sub>	ECL Fall Time, Terminated with 300 Ω to -2.0 V	nsec		4.5	
t <sub>r,BLL</sub>	BLL Rise Time, Terminated with 50 Ω, ac coupled	psec		200	
t <sub>f,BLL</sub>	BLL Fall Time, Terminated with 50 Ω, ac coupled	psec		170	
VSWR <sub>i,H50</sub>	H50 Input VSWR			2:1	
VSWR <sub>o,BLL</sub>	BLL Output VSWR			2:1	

#### Note:

1. BLL outputs are measured with external 150 Ω pull-up resistors to ground. Refer to Figure 23 for additional information.

## HDMP-1012 (Tx), HDMP-1014 (Rx)

### Typical Lock-Up Time

T<sub>c</sub> = 25°C

DIV1	DIV0	HDMP-1012, msec	HDMP-1014, msec	LINK <sup>[1]</sup> , msec
0	0	2.0	2.2	2.5
0	1	3.0	3.2	3.5
1	0	4.5	4.7	5.0
1	1	8.0	11.0	12.0

#### Note:

1. Measured in Local Loop-Back mode with the state machine engaged and 0 cable length.

## HDMP-1012 (Tx), HDMP-1014 (Rx)

### Absolute Maximum Ratings

$T_c = 25^\circ\text{C}$ , except as specified. Operation in excess of any one of these conditions may result in permanent damage to this device.

Symbol	Parameter	Units	Min.	Max.
$V_{EE}$	Supply Voltage	V	-7	+0.5
$V_{IN,ECL}$	ECL Input Voltage	V	-3	+0.5
$V_{IN,BLL}$	H50 Input Voltage	V	-2	+1
$I_{O,ECL}$	ECL Output Source Current	mA		+50
$T_{stg}$	Storage Temperature	$^\circ\text{C}$	-40	+130
$T_J$	Junction Temperature	$^\circ\text{C}$	-40	+130
$T_{max}$	Maximum Assembly Temperature (for 10 seconds maximum)	$^\circ\text{C}$		+260

## HDMP-1012 (Tx)

Thermal Characteristics,  $T_A = 25^\circ\text{C}$

Symbol	Parameter	Units	Typ.
$\Theta_{jc}$	Thermal Resistance Die to Case	$^\circ\text{C}/\text{Watt}$	12
$P_D$	Power Dissipation, $V_{EE} = -5$ volts	Watt	2.0

## HDMP-1014 (Rx)

Thermal Characteristics,  $T_A = 25^\circ\text{C}$

Symbol	Parameter	Units	Typ.
$\Theta_{jc}$	Thermal Resistance Die to Case	$^\circ\text{C}/\text{Watt}$	12
$P_D$	Power Dissipation, $V_{EE} = -5$ volts	Watt	2.6

## I/O Type Definitions

I/O Type	Definition
I-ECL	Input ECL. Similar to 100 K ECL, but with pull-down. Thus if the input is left unconnected, the buffer generates a default value of "0". The input can also be directly connected to ground to generate a "1".
O-ECL	Output ECL. Similar to 100 K ECL but should be terminated with $R_{TT} \geq 300 \Omega$ , and do not exceed 10cm connection distance.
O-BLL	50 matched output driver. Will drive AC coupled 50 $\Omega$ loads, with 150 $\Omega$ pull-up resistors for broad band matching. All unused outputs should have 150 $\Omega$ pull-up resistors, and AC coupled to a 50 $\Omega$ resistor to ground.
I-H50	Input with internal 50 $\Omega$ terminations. Input is diode level shifted so that it can swing around ground. Can be driven with single-end configuration. Commonly used with input single-end AC coupling from an O-BLL driver or another 50 $\Omega$ source, or differential direct coupling from an O-BLL driver.
C	Filter capacitor node.
S	Power supply or ground.

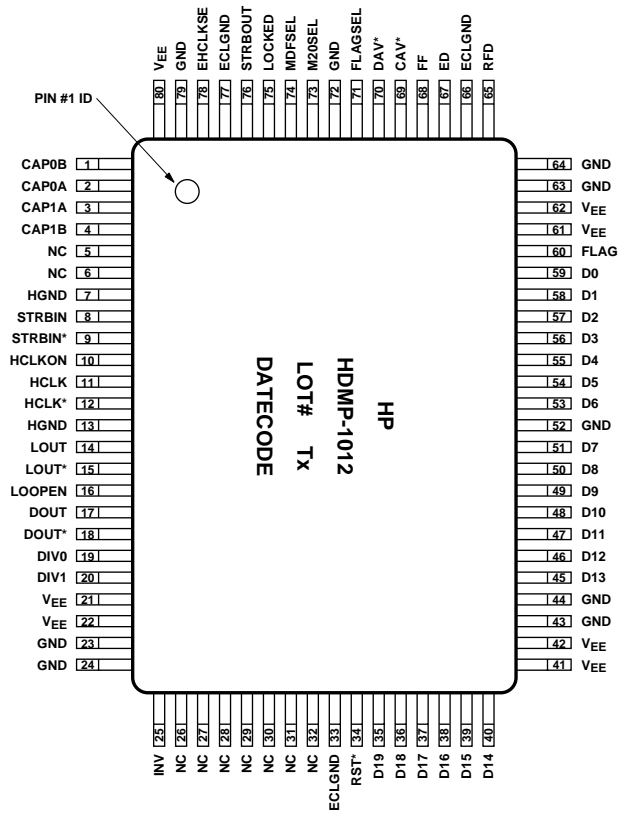

Figure 8. HDMP-1012 (Tx) Package Layout, Top View.

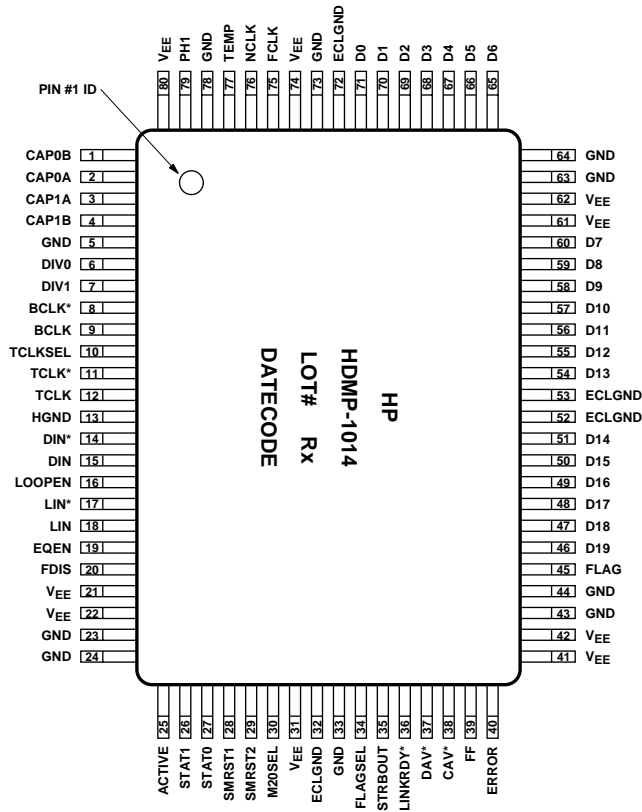

Figure 9. HDMP-1014 (Rx) Package Layout, Top View.

## Tx I/O Definition

Name	Pin	Type	Signal
CAPOA CAPOB CAP1A CAP1B	2 1 3 4	C	<b>Loop Filter Capacitor:</b> CAPOA should be shorted to CAPOB. CAP1A should be shorted to CAP1B. A loop filter capacitor of 0.1 $\mu$ F must be connected across the CAPO and CAP1 inputs to increase the loop time constant.
CAV*	69	I-ECL	<b>Control Word Available Input:</b> This active-low input tells the chip that the user is requesting a control word be transmitted. This pin should only be asserted after the user has determined the RFD line is active for a given frame cycle. When this pin is asserted, the information on the Data inputs is sent as a control frame. If CAV and DAV are asserted simultaneously, CAV takes precedence.
D0 D1 D2 D3 D4 D5 D6 D7 D8 D9 D10 D11 D12 D13 D14 D15 D16 D17 D18 D19	59 58 57 56 55 54 53 51 50 49 48 47 46 45 40 39 38 37 36 35	I-ECL	<b>Data Inputs:</b> 20 Bit data is encoded and transmitted when M20SEL is active; otherwise the 16 least significant bits are encoded and transmitted. The encoded bits are transmitted LSB first. (e.g.: D0 is sent first, through to either D15 or D19, followed by the 4 coding bits C0-C3.)
DAV*	70	I-ECL	<b>Data Available Input:</b> This active-low input tells the chip that the user has valid data to be transmitted. This pin should be asserted only after the user has determined that the RFD line is active for a given frame cycle. When this pin is asserted, the information on the Data and Flag inputs is encoded and sent as a Data frame.
DIV0 DIV1	19 20	I-ECL	<b>VCO Divider Select:</b> These two pins program the VCO divider chain to operate at full speed, half speed, quarter speed or one-eighth speed.
DOUT DOUT*	17 18	O-BLL	<b>Normal Serial Data Output:</b> Output used when LOOPEN is not active. This output is a special <i>buffer line logic</i> driver, which is a 50 $\Omega$ back-terminated ECL compatible output.
ECLGND	33 66 77	S	<b>ECL Ground:</b> Normally 0 volts. This ground is used for the ECL pad drivers. For best performance, coupling of the noisy ECLGND to the clean GND and HGND grounds be minimized.
ED	67	I-ECL	<b>Enable Data:</b> This signal comes from the Rx chip state machine and is used to control the RFD output of the Tx chip. The state machine only allows data to be enabled when both sides of the link have established stable lock.

### Tx I/O Definition (cont'd.)

Name	Pin	Type	Signal
EHCLKSEL	78	I-ECL	<b>EHCLK Enable:</b> When active, this input causes the STRBIN inputs to be used for the transmit serial clock, rather than the internal VCO clock. This is useful for generating extremely low jitter test signals, or for operating the link at speeds that are not within the VCO range. When the STRBIN is active, it is necessary for the data source to take its clock from the link rather than the usual operation where the Link phase-locks onto the data source clock.
FF	68	I-ECL	<b>Fill Frame Select:</b> When neither CAV or DAV is asserted, or when ED is false, fill frames are automatically transmitted to allow the Rx chip to maintain lock. The type of fill frame sent is determined by the state of this pin. FF0s are sent if low, and either FF1a or FF1b is sent if FF is high. The choice of FF1a and FF1b is determined by the state of the cumulative line DC balance.
FLAG	60	I-ECL	<b>Extra Flag Bit:</b> When FLAGSEL is active, this input is sent as an extra data bit in addition to the normal Data inputs. When FLAGSEL is not asserted, this input is ignored and the transmitted Flag bit is internally alternated to allow the Rx chip to perform enhanced frame error detection.
FLAGSEL	71	I-ECL	<b>Flag Bit Mode Select:</b> When this input is high, the extra FLAG bit input is sent as an extra transparent data bit. Otherwise, the FLAG input is ignored and the transmitted flag bit is internally alternated by the transmitter. The Rx chip can provide enhanced frame error detection by checking for strict alternation of the flag bit during data frames. The FLAGSEL input on the Rx chip should be set to the same value as the Tx FLAGSEL input.
GND	23 24 43 44 52 63 64 72 79	S	<b>Ground:</b> Normally 0 volts. This ground is used for everything other than the noisy ECL outputs.
HCLK HCLK*	11 12	O-BLL	<b>High Speed Clock Monitor:</b> Used to monitor actual clock signal used to transmit the serial data. This signal will either be the divided VCO output, or the divided EHCLK external clock input, depending on the value of the EHCLKSEL input.
HCLKON	10	I-ECL	<b>HCLK Power-down Control:</b> When this pin is de-asserted, the HCLK, HCLK* outputs are powered down to reduce power dissipation.
HGND	7 13	S	<b>High Speed Ground:</b> Normally 0 volts. This ground is used to provide a clean reference for STRBIN and STRBIN* inputs. For optimum impedance matching, it is suggested that the physical distance between this pin and the ground plane be minimized.



### Tx I/O Definition (cont'd.)

Name	Pin	Type	Signal
INV	25	O-ECL	<b>Invert Signal:</b> A high value of INV implies that the current frame is being sent inverted to maintain long-term DC balance. With a buffer, or pulled down with a 1K resistor to $V_{EE}$ and ac coupled, this signal is useful as an aid to analyzing the serial output stream with an oscilloscope.
LOCKED	75	O-ECL	<b>Loop In-lock Indication:</b> This signal indicates the lock status of the Tx PLL. A high value indicates lock. This signal is normally connected to the SMTRST1 reset input of the Rx state machine to force the link into the start-up state until the Tx PLL has locked. This signal may give multiple false-lock indications during the acquisition process, so should be debounced if it is used for any other purpose than to drive the Rx chip.
LOOPEN	16	I-ECL	<b>Loop Back Control:</b> Input which controls whether the DOUT, DOUT*, or the LOUT, LOUT* outputs are currently enabled. If active, LOUT, LOUT* are enabled. The unused output is powered down to reduce dissipation.
LOUT LOUT*	14 15	O-BLL	<b>Loop Back Serial Data Output:</b> Output used when LOOPEN is active. Typically this output will be used to drive the LIN, LIN* inputs of the Rx chip.
M20SEL	73	I-ECL	<b>16 or 20 Bit Word Select:</b> When this signal is high, the link operates in 20 Bit data transmission mode. Otherwise, the link operates in 16 Bit mode.
MDFSEL	74	I-ECL	<b>Select Double Frame Mode:</b> When this signal is high, the PLL expects a 1/2 speed parallel clock at STRBIN. The chip then internally multiplies this clock and produces a full-rate parallel clock at STRBOUT. Note that the phase relationship of STRBIN to STRBOUT and the sampling point change with asserting MDFSEL, as shown in the Tx timing diagram. This feature is provided so that either a 40 bit or 32 bit word can be easily transmitted as two 20, or two 16 bit words. When MDFSEL is low, the PLL expects a full-rate parallel clock at STRBIN.
RFD	65	O-ECL	<b>Ready for Data:</b> Output to tell the user the Link is ready to transmit data. This pin is a retimed version of the ED input, which is driven by the Rx chip state machine controller.
RST*	34	I-ECL	<b>Chip Reset:</b> This active-low pin initializes the internal chip registers. It should be asserted during power up for a minimum of 5 parallel-rate clock cycles to ensure a complete reset.
STRBIN STRBIN*	8 9	I-H50	<b>Data Clock Input:</b> When EHCLKSEL is low, this input is phase locked and multiplied to generate the high speed serial clock. The chip expects a clock frequency which is equal to the input frame rate if MDFSEL (double frame mode) is low, and 1/2 the frame rate if MDFSEL is high. When EHCLKSEL is high, the PLL is bypassed, and STRBIN directly becomes the high speed serial clock. Refer to the Tx Timing diagram for the phase relationship between STRBIN, data and STRBOUT.

**Tx I/O Definition (cont'd.)**

<b>Name</b>	<b>Pin</b>	<b>Type</b>	<b>Signal</b>
STRBOUT	76	O-ECL	<b>Frame-rate Data Clock Output:</b> This output is always a frame rate clock derived from STRBIN. With a buffer or pulled down with a 1K resistor to $V_{EE}$ and ac- coupled, this output is ideal for triggering an oscilloscope for examining the serial output eye pattern DOUT or LOUT.
$V_{EE}$	21 22 41 42 61 62 80	S	<b>Power:</b> Normally $-5\text{ V} \pm 10\%$ .

## Rx I/O Definition

Name	Pin	Type	Signal
ACTIVE	25	I-ECL	<b>Chip Enable:</b> This input is normally driven by the Rx state machine output. The ACTIVE signal is internally retimed by STRBOUT and presented to the user as the LINKRDY signal. This is how the Rx state machine signals the user that the start-up sequence is complete.
BCLK BCLK*	9 8	O-BLL	<b>VCO Monitor Output:</b> These pins provide access to the internal VCO clock.
CAP0A CAP0B CAP1A CAP1B	2 1 3 4	C	<b>Loop Filter Capacitor:</b> CAP0A should be shorted to CAP0B. CAP1A should be shorted to CAP1B. A loop filter capacitor of 0.1 $\mu$ f must be connected across the CAP0 and CAP1 inputs to increase the loop time constant.
CAV*	38	O-ECL	<b>Control Frame Available Output:</b> This active-low output indicates that the Rx chip data outputs are receiving Control Frames. False CAV indications may be generated during link startup.
D0 D1 D2 D3 D4 D5 D6 D7 D8 D9 D10 D11 D12 D13 D14 D15 D16 D17 D18 D19	71 70 69 68 67 66 65 60 59 58 57 56 55 54 51 50 49 48 47 46	O-ECL	<b>Data Outputs:</b> 20 Bit data is received and decoded when M20SEL is active; otherwise 16 bit data is decoded and the D16-D19 bits are undefined.
DAV*	37	O-ECL	<b>Data Available Output:</b> This active-low output indicates that the Rx chip data outputs, D0..D19, have received data frames. Data should be latched on the rising edge of STRBOUT. Note that during link startup, false data indications may be given. The DAV* and LINKRDY outputs can be used together to avoid confusion during link startup.
DIN DIN*	15 14	I-H50	<b>Normal Serial Data Input:</b> This is the input used when LOOPEN is not active. When LOOPEN is high, the loop back data inputs LIN, LIN* are used instead. An optional cable equalizer may be enabled for the DIN, DIN* inputs by asserting EQEN.
DIV0 DIV1	6 7	I-ECL	<b>VCO Divider Select:</b> These two pins program the VCO divider chain to operate at full speed, half speed, quarter speed or one-eighth speed.

## Rx I/O Definition (cont'd.)

Name	Pin	Type	Signal
ECLGND	32 52 53 72	S	<b>ECL Ground:</b> Normally 0 volts. This ground is used for the ECL pad drivers. For best performance it is suggested that coupling of the noisy ECLGND to the clean GND and HGND grounds be minimized.
EQEN	19	I-ECL	<b>Enable Input for Cable Equalization:</b> When asserted, this signal activates the cable equalization amplifier on the DIN, DIN* serial data inputs.
ERROR	40	O-ECL	<b>Received Data Error:</b> Asserted when a frame is received that does not correspond to either a <i>valid</i> Data, Control, or Fill frame encoding. When FLAGSEL is not active, the Rx chip also tests for strict alternation of flag bits during data frames. A flag bit alternation error will also cause an ERROR indication.
FCLK	75	O-ECL	<b>Frame Clock Monitor:</b> Leave unterminated in normal use.
FDIS	20	I-ECL	<b>Frequency Detector Disable Input:</b> When active, this input disables the Rx PLL Frequency detector and enables a phase detector. The Frequency detector is used during the start-up sequence to acquire wide-band lock on Fill Frames, but must be disabled prior to sending data patterns. This input is normally controlled by the Rx state machine.
FF	39	O-ECL	<b>Fill Frame Status:</b> During a given STRBOUT clock cycle, if neither DAV, CAV, or ERROR are active, then the currently received frame is a Fill frame. The type of fill frame received is indicated by the FF pin. If FF is low, then FF0 has been received. If FF is high, then either FF1a or FF1b has been received.
FLAG	45	O-ECL	<b>Flag Bit:</b> If both Tx and Rx have FLAGSEL asserted, this output indicates the value of the transmitted flag bit, then this received bit can be treated just like an extra data bit. If both Tx and Rx have FLAGSEL set to low, FLAG is used to differentiate the even frame from the odd frame in the line code.
FLAGSEL	34	I-ECL	<b>Flag Bit Mode Select:</b> When this input is high, the extra FLAG bit output is effectively an extra transparent data bit. Otherwise, the FLAG bit is checked for alternation during data frames. Any break in strict alternation results in an ERROR indication to the user.
GND	5 23 24 33 43 44 63 64 73 78	S	<b>Ground:</b> Normally 0 volts. This ground is used for all the core logic other than the output drivers.
HGND	13	S	<b>High Speed Ground:</b> Normally 0 volts. This ground is used to provide clean references for the high speed DIN, DIN*, LIN, LIN*, TCLK, TCLK* inputs.

## Rx I/O Definition (cont'd.)

Name	Pin	Type	Signal
LIN LIN*	18 17	I-H50	<b>Loop Back Serial Data Input:</b> Use this input when LOOPEN is active. Unlike the DIN, DIN* inputs, this input does not have a cable equalizer. In normal usage, this input will be connected to the Tx chip LOUT, LOUT* outputs. This allows the user to check the near-end functionality of the Tx and Rx pair independent of the transmission medium
LOOPEN	16	I-ECL	<b>Loop Back Control:</b> When asserted, this signal causes the loop back data inputs LIN, LIN* to be used instead of the normal data inputs DIN, DIN*.
LINKRDY*	36	O-ECL	<b>Link Ready Indicator:</b> This active-low output is a retimed version of the ACTIVE input. ACTIVE is normally driven by the Rx state machine output. LINKRDY* then indicates that the startup sequence is complete and that the data and control indications are valid.
M20SEL	30	I-ECL	<b>16 or 20 Bit Word Select:</b> When this signal is high, the link operates in 20 Bit data reception mode. Otherwise, the link operates in 16 Bit mode and data outputs D16-D19 are undefined.
NCLK	76	O-ECL	<b>Nibble Clock Monitor:</b> Leave unterminated in normal use.
TEMP	77	T	<b>Temperature Sense Diode:</b> Used during wafer and package test only. It should be left open.
PH1	79	O-ECL	<b>Phase Detector Test Output:</b> The output from the phase/frequency detector in the Rx PLL. When PH1 is high, the VCO should increase frequency. When low, the VCO should decrease frequency.
SMRST0* SMRST1*	28 29	I-ECL	<b>State Machine Reset Inputs:</b> Each of these active-low input pins reset the Rx state machine to the initial start-up state. This initiates a complete PLL restart and handshake at both ends of the duplex link. Normally, SMCRST0* is connected to a power-up reset circuit or a host system reset signal. The SMCRST1* input is normally connected to the Tx LOCKED output. The LOCKED signal holds the state-machine in the start-up state until the Tx PLL is locked.
STAT0 STAT1	27 26	O-ECL	<b>State Machine Status Outputs:</b> These outputs indicate the current state-machine state. They are used to directly control the Tx ED, Tx FF, Rx FDIS, and Rx ACTIVE lines.
STRBOUT	35	O-ECL	<b>Recovered Frame-rate Data Clock Output:</b> This output is the PLL recovered frame rate clock. D0-D19, FLAG, DAV, CAV, FF, LINKRDY, and ERROR should all be latched on the rising edge of STRBOUT.
TCLK TCLK*	12 11	I-H50	<b>External VCO Replacement Test Clock:</b> When TCLKSEL is enabled, this input is used in place of the normal VCO signal, effectively disabling the PLL and allowing the user to provide an external retiming clock for testing.
TCLKSEL	10	I-ECL	<b>Enable Test Clock Input:</b> When this input is active, the TCLK, TCLK* inputs are used in place of the normal VCO signal. This feature is useful both for synchronous systems and for chip testing.

**Rx I/O Definition (cont'd.)**

Name	Pin	Type	Signal
V <sub>EE</sub>	21 22 31 41 42 61 62 74 80	S	<b>Power:</b> Normally -5 V +10%

## Mechanical Dimensions and Surface Mount Assembly Recommendations

Both the HDMP-1012 and HDMP-1014 are implemented in an industry standard M-Quad 80 package. The package outline

dimensions conform to JEDEC plastic QFP specifications and are shown below in Figure 10. The M-Quad 80 package material is aluminum and the leads have been formed into a “Gull-Wing” configuration for surface mounting.

We recommend keeping the package temperature,  $T_c$ , below  $75^{\circ}\text{C}$ . Forced air cooling may be required.

## M-Quad 80 Package Information

Item	Details
Package Material	Aluminum
Lead Finish Material	85/15 Sn/Pb
Lead Finish Thickness	300 - 600 $\mu$ inches
Lead Coplanarity	0.004 inches maximum

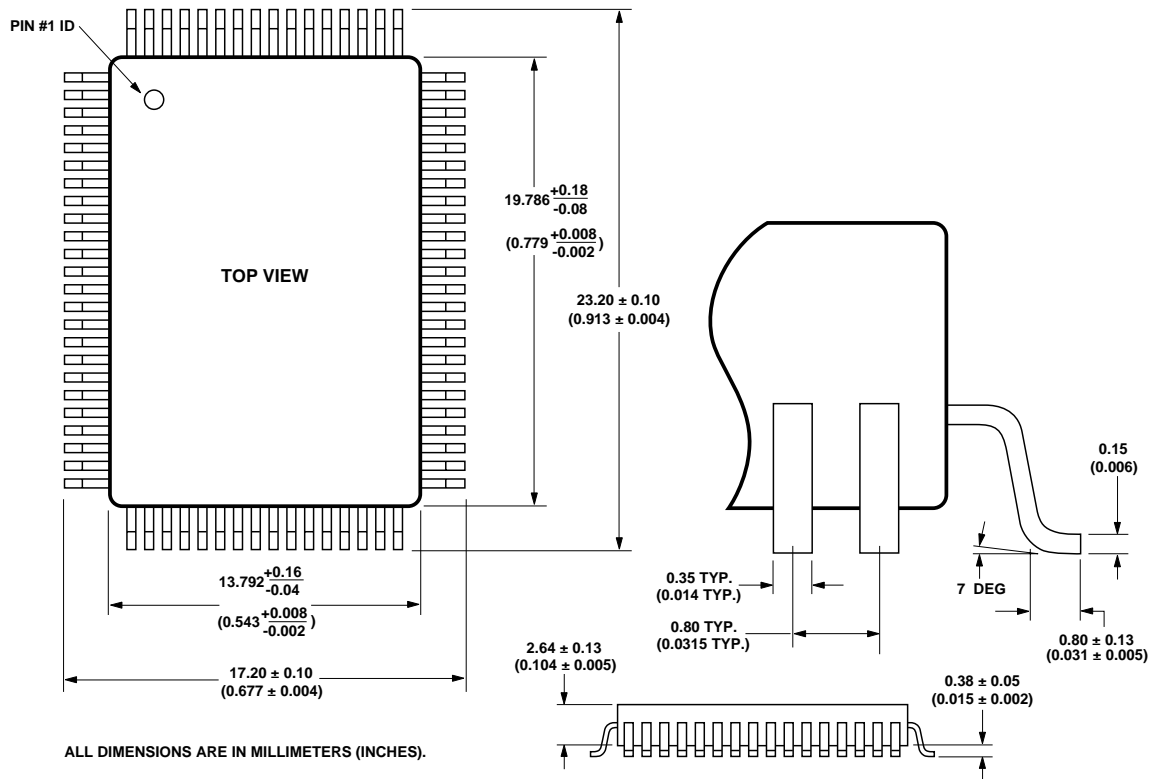

Figure 10. Mechanical Dimensions of HDMP-1012 and HDMP-1014.

## Appendix I: Additional Internal Architecture Information

### Line Code Description

The HDMP-1012/1014 line code is Conditional Invert Master Transition (CIMT), illustrated in Figure 11. The CIMT line uses three types of frames: data frames, control frames, and fill frames. Fill frames are internally generated by the Tx chip for use during link start up and when there is no input from the user.

Each frame consists of a Data Field (D-Field) followed by a Coding Field (C-Field). The D-Field can be either 16-bits or 20-bits wide, depending on link configuration. The C-Field has a master transition which serves as a fixed timing reference for the receiver's clock recovery circuit. Users can send arbitrary data carried by Data or Control Frames. The dc balance of the line code is automatically enforced by the Tx. Fill frames have a single rising edge at the

master transition which is used for clock recovery and frame synchronization at the receiver.

Detailed coding schemes are described in the following subsections. All the tables given in this section show data bits in the same configuration as a scope display. In other words, the leftmost bit in each table is the first bit to be transmitted in time, while the rightmost bit is the last bit to be transmitted.

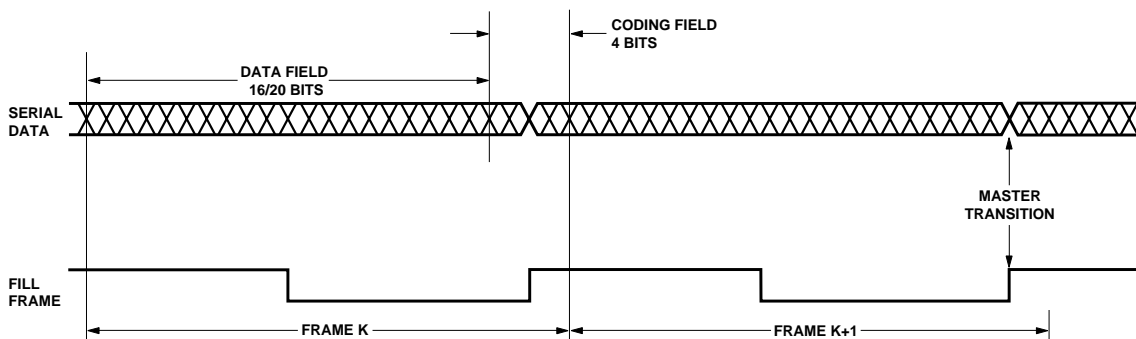

Figure 11. HDMP-1012/1014 (Tx/Rx Pair) Line Code.

### Data Frame Codes

When not in FLAGSEL mode, the FLAG bit is not user controllable and is alternately sent as 0 and 1 by the Tx chip during data frames to provide enhanced error detection. Control and Fill frames do not cause toggling between even and odd frames to occur (The FLAG bit is not available during control frames). The receiver performs a differential detection to make sure that every data frame received is the opposite pattern from the previous frame. If a break in the strict alternation is observed, a

frame error is flagged by asserting the Rx ERROR output. This pattern detection makes it impossible for a static input data pattern to generate an undetectable false lock point in the transmitted data stream. The detection also reduces the probability that the loop could lock onto random data at a point away from the true master transition for any significant time before it would be detected as a false lock. This mode can detect all single-bit errors in the C-field (non-data bit fields) of the frame.

When the chip is in FLAGSEL mode, the extra FLAG bit is freely user definable as an extra data bit. This provides a 17th bit in 16 bit mode, and a 21st bit in 20 bit mode. The probability of undetected false lock is higher, but the users (e.g., SCI-FI) that need the extra bit can detect false lock at a higher level of the network protocol with clock recovery circuits, etc. If the higher level protocols consistently receive wrong data, they can initiate a link restart by resetting the Rx state machine.



## HDMP-1012 (Tx), HDMP-1014 (Rx)

### Operating Modes

M20SEL	FLAGSEL	Description
0	0	16 bit data plus error checking
0	1	16 bit data plus FLAG
1	0	20 bit data plus error checking
1	1	20 bit data plus FLAG

## HDMP-1012 (Tx), HDMP-1014 (Rx)

### Data Frame Structure

M20SEL Not Asserted (16 bit data mode)

Data Status	Flag bit	D-Field	C-Field
True	0	$D_0 - D_{15}$	1101
Inverted	0	$\overline{D_0 - D_{15}}$	0010
True	1	$D_0 - D_{15}$	1011
Inverted	1	$\overline{D_0 - D_{15}}$	0100

## HDMP-1012 (Tx), HDMP-1014 (Rx)

### Data Frame Structure

M20SEL Asserted (20 bit data mode)

Data Status	Flag bit	D-Field	C-Field
True	0	$D_0 - D_{19}$	1101
Inverted	0	$\overline{D_0 - D_{19}}$	0010
True	1	$D_0 - D_{19}$	1011
Inverted	1	$\overline{D_0 - D_{19}}$	0100

### Control Frame Codes

There are  $2^{18}$  control words provided in 20 bit mode. If the user desires to send a control word, his lower 9 bits ( $D_0-D_8$ ) are sent as bits  $D_0-D_8$  of the D-Field. The user's next 9 bits ( $D_9-D_{17}$ ) are sent as bits  $D_{11}-D_{19}$  of

the D-Field. The control frame is either inverted or not inverted as needed to maintain balance, with the coding bits 0011 used to indicate true control, and the bits 1100 used to indicate complement control. The bits  $d_9$  and  $d_{10}$  are always forced to 0 1 for true control frames and 1 0

for complement control frames. These middle bits are used to distinguish control frames from fill frames, which always have the middle bits set to either 00, 11, or 10. Similarly, there are  $2^{14}$  control words provided in 16 bit mode.

## HDMP-1012 (Tx), HDMP-1014 (Rx)

### Control Frame Structure

M20SEL Not Asserted (16 bit mode)

D-Field				C-Field			
D0 - D6	D7	D8	D9 - D15	C0	C1	C2	C3
$D_0 - D_6$	0	1	$D_7 - D_{15}$	0	0	1	1
$\overline{D_0} - \overline{D_6}$	1	0	$\overline{D_7} - \overline{D_{15}}$	1	1	0	0

## HDMP-1012 (Tx), HDMP-1014 (Rx)

### Control Frame Structure

M20SEL Asserted (20 bit mode)

D-Field				C-Field			
D0 - D8	D9	D10	D11-D19	C0	C1	C2	C3
$D_0 - D_8$	0	1	$D_9 - D_{19}$	0	0	1	1
$\overline{D_0} - \overline{D_8}$	1	0	$\overline{D_9} - \overline{D_{19}}$	1	1	0	0

### Fill Frame Codes

Two logical fill frames are provided: FF0 and FF1. FF0 is physically a 50% duty cycle wave form with its sole rising edge

occurring between C1 and C2. Logical FF1 toggles between two different physical codes, the first of which advances the falling edge of FF0 by one bit, the second of

which retards the falling edge of FF0 by one bit. Two logical fill frame types are required for link start up in duplex mode.

## HDMP-1012 (Tx), HDMP-1014 (Rx)

### Fill Frame Structure

M20SEL Not Asserted (16 bit mode)

Fill Frame	D-Field			C-Field
0	11111111	10	00000000	0011
1a	11111111	11	00000000	0011
1b	11111111	00	00000000	0011

## HDMP-1012 (Tx), HDMP-1014 (Rx)

### Fill Frame Structure

M20SEL Asserted (20 bit mode)

Fill Frame	D-Field			C-Field
0	1111111111	10	0000000000	0011
1a	1111111111	11	0000000000	0011
1b	1111111111	00	0000000000	0011

## HDMP-1014 (Rx)

### Detectable Error States

M20SEL Not Asserted (16 bit mode)

D-Field			C-Field
xxxxxxx	xx	xxxxxxx	x00x
xxxxxxx	xx	xxxxxxx	x11x
xxxxxxx	0x	xxxxxxx	1100
xxxxxxx	11	xxxxxxx	1100
xxxxxxx	xx	xxxxxxx	1010
xxxxxxx	xx	xxxxxxx	0101

## HDMP-1014 (Rx)

### Detectable Error States

M20SEL Asserted (20 bit mode)

D-Field			C-Field
xxxxxxxxx	xx	xxxxxxxxx	x00x
xxxxxxxxx	xx	xxxxxxxxx	x11x
xxxxxxxxx	0x	xxxxxxxxx	1100
xxxxxxxxx	11	xxxxxxxxx	1100
xxxxxxxxx	xx	xxxxxxxxx	1010
xxxxxxxxx	xx	xxxxxxxxx	0101

## Tx Operation Principles

The HDMP-1012 (Tx) is implemented in a high performance silicon bipolar process. The Tx performs the following functions for link operation:

- Phase lock to frame rate clock
- Clock multiplication
- Frame encoding
- Multiplexing

In normal operation, the Tx phase locks to a user supplied frame rate clock and multiplies the frequency to produce the high speed serial clock. When locked, the Tx indicates that it is locked by asserting the LOCKED output. When the ED input is asserted, the Tx asserts the RFD signal

indicating that it is now ready to transmit data or control frames.

The Tx can accept either 16 or 17 bit wide parallel data and produce a 20 bit frame. It also can accept 20 or 21 bit data and produce a 24 bit frame. Similarly, either 14 bit or 18 bit control words can be transmitted in a 20 bit or 24 bit frame respectively.

## Tx Encoding

A simplified block diagram of the transmitter is shown in Figure 4. The PLL/Clock Generator locks onto the incoming frame rate (or one-half frame rate) clock and multiplies it up to the serial clock rate. It also generates all the internal clock signals required by the Tx chip.

The data inputs, D0-D19, as well as the control signals; ED, FF, DAV\*, CAV\*, and FLAG are latched in on the rising edge of an internally generated frame rate clock. The data field is then encoded depending on the state of the control signals. At the same time, the coding field is generated. At this point, the entire frame has been constructed in parallel form and its sign is determined. This frame sign is compared with the accumulated sign of previously transmitted bits to decide whether to invert the frame. If the sign of the current frame is the same as the sign of the previously transmitted bits, then the frame is inverted. If the signs are opposite, the frame is not inverted. No inversion is

performed if the frame is a fill frame.

The Output Select block allows the user to select between two sets of differential high speed serial outputs. This feature is useful for loop back testing. If LOOPEN is high, LOUT is enabled and DOUT is disabled. If LOOPEN is low, DOUT is enabled and LOUT is disabled.

The active-low RST\* input resets the internal registers to a balanced state. This pin should be held low for at least five frame rate clock cycles to ensure a complete reset.

The Data Field and Control Field are encoded depending on ED, FF, DAV\*, CAV\*, FLAG, FLAGSEL, M20SEL as well as two internally generated signals, O/E and ACCMSB.

When FLAGSEL is high, O/E is equivalent to FLAG. This is equivalent to adding an additional bit to the data field. When FLAGSEL is low, O/E alternates

between high and low for data frames. This allows the link to perform more extensive error detection when the extra bit is unused.

ACCMSB is the sign of the previously transmitted data. This is used to determine which type of FF1 should be sent. When ACCMSB is low, FF1a is sent and when ACCMSB is high, FF1b is sent. This effectively drives the accumulated offset of transmitted bits back toward the balanced state.

### Tx Phase-Locked Loop

The block diagram of the transmitter phase-locked loop is shown in Figure 12. It consists of a sequential frequency detector, loop filter, VCO, clock generation circuitry, and a lock indicator. The outputs of the frequency detector pass through a charge pump filter that controls the center frequency of the VCO. These outputs also go to the VCO directly to effectively add a zero

in the loop response. An external high-speed clock can be used instead of the VCO clock. This is accomplished by applying a high signal to EHCLKSEL and a differential clock to STRBIN.

One of four frequency bands may be selected by applying appropriate inputs to DIV0 and DIV1. The VCO or STRBIN frequency is divided by N, where N is 1, 2, 4, or 8 corresponding to the binary number represented by DIV1, DIV0. This divided version of the VCO clock or STRBIN is used as the serial rate clock and is available as a differential signal at the HCLK output.

A clock generator block creates all the clock signals required for the chip. Depending on M20SEL, STRBOUT is either HCLK/20 or HCLK/24. If MDFSEL is low, then STRBOUT is a phase-locked version of STRBIN. If MDFSEL is high, STRBOUT is twice the frequency of STRBIN.

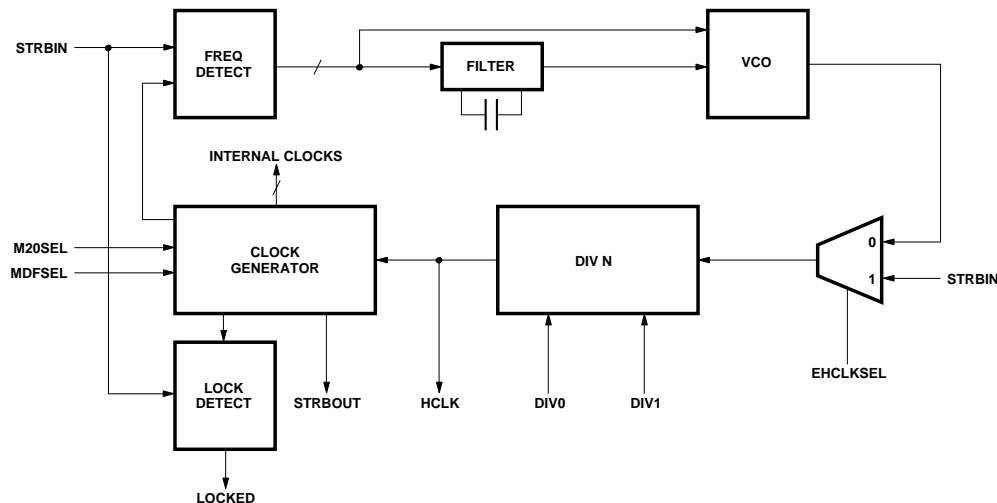

Figure 12. HDMP-1012 (Tx) Phase-Locked Loop.

The lock detect circuit samples STRBIN with phase shifted versions of STRBOUT. If the samples are not the proper values, the LOCKED signal goes low and stays low for at least two frames.

### Rx Operation Principles

The HDMP-1014 (Rx) is monolithically implemented in a high performance 25 GHz  $f_t$  bipolar process. When properly configured, the Rx can accept 20B/24B CIMT line code frames, and then output parallel 16B/17B/20B/21B Data Word or 14B/18B Control Word. The Rx provides the following functions for link operation:

- Clock recovery
- Frame synchronization
- Data recovery
- Demultiplexing
- Frame decoding
- Frame error detection
- Link state control

### Rx Encoding

Figure 5 shows a simplified block diagram of the receiver. The data path consists of an Input Select, an Input Sampler, a Frame Demultiplexer, a Control Field (C-Field) Decoder, and a Data Field (D-Field) Decoder. An on-chip phase-locked loop (PLL) is used to extract timing reference from the serial input (DIN or LIN). The PLL includes a Phase-Frequency Detector, a Loop Filter, and a variable-frequency oscillator (VCO). All the RX internal clock signals are generated from a Clock Generator. The Clock Generator can be driven either by internal VCO or external signal, TCLK, depending on the Clock Select configuration.

Integrated on the chip is a Link-Control State Machine for link status monitoring and link startup. Figure 13 shows the details of the Input Select. The Input Select chooses either nominal serial data (DIN) or loopback (LIN) signal for the Input Sampler's input. If loopback enable (LOOPEN) is asserted, the LIN input is selected. Also included in the Input Selector is cable equalization circuitry. When coaxial cable is used as the transmission media, by setting EQEN=1 (enable equalization), the equalization circuitry is in the DIN signal path and can compensate for high-frequency cable loss.

Because the Data Field of the CIMT line code can be either 16-bit or 20-bit wide, the width selection for Rx is made by setting the input pin M20SEL (Figure 5). If M20SEL=1, then the Rx is configured to accept serial input with 20-bit data field, i.e., 24 bits per frame. If M20SEL = 0, 16-bit data field is selected.

### HDMP-1014 (Rx) Phase-Locked Loop

A more detailed block diagram for the Rx phase-locked loop (PLL) is shown in Figure 14. In the PLL, the phase of the serial input, SIN, is compared with synchronizing signals from the internal clock generator, using either a phase detector or a frequency detector. The frequency detector disable signal, FDIS, selects which detector to use. If synchronization in a link is not yet established, the HDMP-1012 (Tx) should send out Fill Frame 0 (FF0) or Fill Frame 1 (FF1) to the remote Rx. By setting FDIS=0, the Rx uses

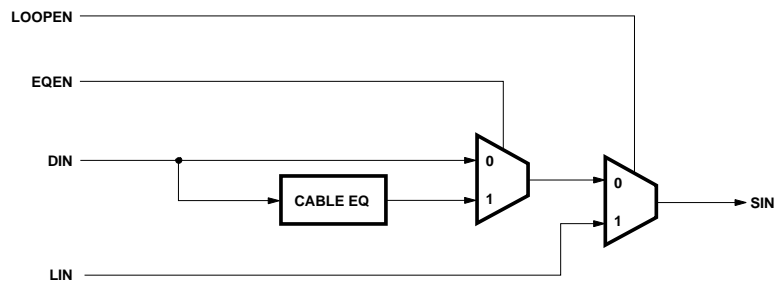

Figure 13. HDMP-1014 (Rx) Input Selector.

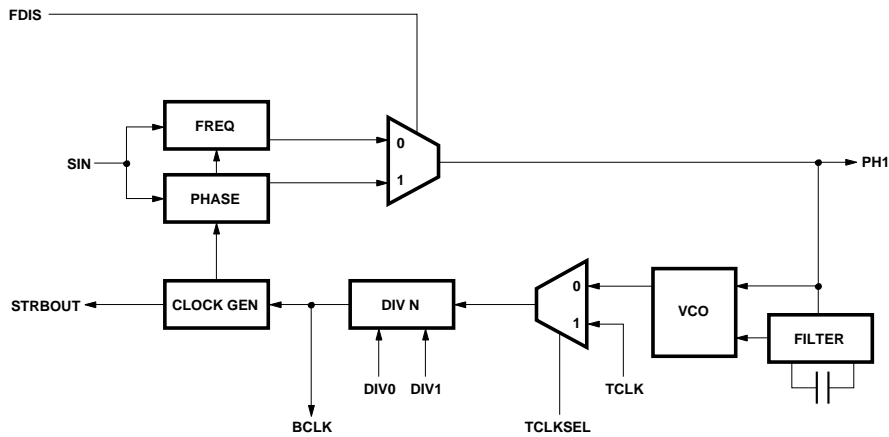

Figure 14. HDMP-1014 (Rx) Phase-Locked Loop.

the frequency detector to align its internal clock with the rising edge of FF0/FF1. Once frequency lock is accomplished, FDIS can be set to 1, then the PLL uses only the phase detector for synchronization adjustment and the Rx is ready to receive data. Due to the narrow frequency acquisition range of the phase detector, the frequency detector is used for internal frequency acquisition. The frequency detector, however, can only work with FF0 and FF1 and it is necessary for the PLL selecting the phase detector (by setting FDIS=1) before receiving any random data.

The output of the phase-frequency detector is externally available through pin PHI. An external clock source can also be used (through pin TCLK) by setting TCLKSEL=1. To broaden the usable frequency range of the chip, there is a programmable divider before the clock generator. The VCO or TCLK frequency can be divided by 1, 2,

4, 8 by setting DIV1, DIV0 = 00, 01, 10, 11 (see Operating Rate Tables).

### HDMP-1014 (Rx) Decoding

In Figure 5, the frame demultiplexer de-serializes the recovered serial data from the Input Sampler, and outputs the resulting parallel data one frame at a time. Every frame is composed of a 16-bit or 20-bit Data Field (D-Field) and a 4-bit Control Field (C-Field). The C-Field, C0-C3, together with the two center bits of the D-Field (D9 and D10 for 20 bit mode, D7 and D8 for 16 bit mode) are then decoded by the C-Field decoder to determine the content of the frame. The D-Field decoder is controlled by the outputs of the C-Field decoder. If an inverted Data Word or Control Word is detected, the D-Field decoder will automatically invert the D-Field data. If a Control Frame is detected, the D-Field decoder will shift the bottom half of the D-Field so that the outputs are at

pin D0 - D17 (if M20SEL = 1) or at pin D0 - D13 (if M20SEL = 0). A data Frame is detected by the receiver when DAV = 1. A control Frame is detected by the receiver if CAV = 1. A Fill Frame is detected by the receiver if DAV = 0 and CAV = 0.

The C-Field decoder will set iERR = 1 when it detects an error. The internal error bit (iERR) is combined with the internal flag bit (iFLAG) and the flag-bit mode-select signal (FLAGSEL) to produce the externally available error bit (ERROR) and flag (FLAG) bits. If FLAGSEL=1, the FLAG can be used as an extra data bit

- ERROR=iERR.
- FLAG=iFLAG.
- If a Fill Frame is detected, then FLAG=0.
- If a Control Frame is detected, FLAG should be ignored.

If FLAGSEL=0, the serial input is assumed to consist of alternating

even frames (iFLAG=0) and odd frames (iFLAG=1).

- If iERR=1, then ERROR=1.
- If a Fill Frame is detected, then FLAG=0.
- If a Data Frame is detected, then FLAG=iFLAG, and iFLAG should alternate between 0 and 1, starting with 0 and ending with 1; otherwise, ERROR=1.
- If a Control Frame is detected, then FLAG automatically alternates between 0 and 1, starting with 0.

The even or odd feature allows a 32/40-bit wide data word to be transmitted through the link. A 2:1 multiplexer and a 1:2 demultiplexer are required. FLAG is used to synchronize the even and odd frames. Note, both Data and Control Frames can be transmitted as even/odd pairs, but only Data Frames can be detected for out of order errors.

### **HDMP-1014 (Rx) Link-Control State Machine Operation Principle**

The link-control state machine (SMC) on the Rx chip provides a link handshake protocol enabling the duplex link to transition from frequency acquisition and training mode into data mode.

The HDMP-1012/1014 Tx/Rx link uses an explicit frequency acquisition mode at startup that operates on a square-wave training sequence. This makes it possible to use a VCO with a very wide tuning range yet avoid the harmonic false lock problems associated with other circuits of this type.

Using the SMC, a full duplex data channel can be implemented

without additional controller or hardware.

### **The State Machine Handshake Protocol**

Figure 1d shows a simplified block diagram of the HDMP-1012/1014 data channel configured for full duplex operation. Two HDMP-1012/1014 chipsets are required to perform the handshake in parallel. There are three states that the link must go through to complete the link startup process:

- State 0: Frequency Acquisition
- State 1: Waiting for Peer
- State 2: Sending Data

Each side of the link decides which of the three states that it should be in. The decision is based on its own past memory and the type of frame that it is currently receiving from the other side of the link.

Considering only the local port of the link, there is a transmitter (Tx), a receiver (Rx) and a state machine controller (SMC). The SMC entity, although logically distinct, is implemented on the same die as the Rx chip. The SMC monitors the data frame status indicators (ERROR, DAV, CAV, FW) from the Rx, and is able to force (or control) various characteristics of the Tx and the Rx chips. The Tx chip has the following controllable features:

- It can be forced to send a Fill Frame using the ED input.
- The type of Fill Frame sent can be controlled using the FF input.

The Rx Chip has the following controllable features:

- It can be in Frequency acquisition or Phase-lock/Data reception mode depending on the state of the FDIS input.
- It can be enabled for data reception or set in a mode in which data frames are ignored depending on the ACTIVE input.

The Rx chip can also distinguish between various types of frames. It can also communicate the frame type to the SMC. The various frame types are:

- Fill Frame 0, (FF0)
- Fill Frame 1 a/b (FF1)
- Data/Control frames (Data)
- Error frames (ERROR)

The SMC can also be reset by either the SMCRST0\* or SMCRST1\* inputs. Usually one of these inputs is used for power-on reset, and the other is connected to the Tx LOCKED output.

This holds the SMC in state 0 until the transmitter PLL has locked.

Figure 15 shows the state diagram of the SMC. The SMC is debounced by allowing state transitions to be made only after at least 2 consecutive frames give the same indication. This prevents single bit errors from causing false state transitions. In addition to this debouncing mechanism, when two consecutive ERROR or Resets occur, a timer is enabled forcing the SMC into state zero for 128 frame times. Any transition out of this initial state can only occur after the link has been error-free for 128 frames. This prevents false transitions from being made during the bit-slipping that occurs in the initial frequency acquisition of both the Tx and Rx PLLs.

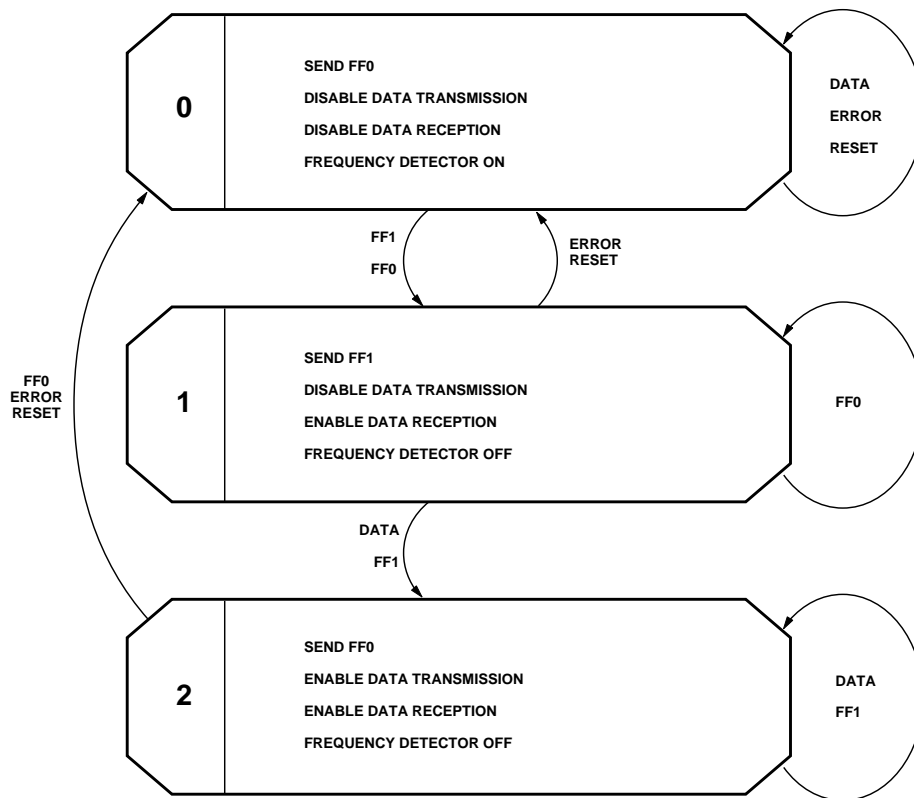

Figure 15. HDMP-1014 (Rx) State Machine State Diagram.

When the local port is in State 0, it is in the reset state, where both local Tx and Rx parallel interfaces are disabled. The local Tx transmits FF0 continuously, and the local Rx PLL is in the frequency detection mode. When the local Rx is phase-locked to the remote Tx, it transitions to State 1. The local Tx transmits FF1 to acknowledge the phase-locked condition (its parallel input is still disabled). The local Rx PLL is in the phase detection mode and its parallel output is enabled. When in State 2, the two-way synchronization between the local port and the remote port is established. Both local Tx and Rx parallel interfaces are enabled, and the local Rx PLL is in the

phase detection mode. Parallel data can be sent by the local Tx, and at the same time, received by the local Rx.

The Rx chip has the state machine logic built in. The SMC has two status outputs, STAT0 and STAT1, that control the various features of the two chips depending on the current state. The TX inputs that need to be controlled are FF and ED. The RX inputs that need to be controlled are FDIS and ACTIVE. To control the chips as shown in the state diagram of Figure 15, the following interchip connections must be made (Figure 16):

- Tx FF is driven by STAT1
- Tx ED is driven by STAT0
- Rx FDIS is driven by STAT1
- Rx ACTIVE is driven by STAT1
- TX RST and RX SMCRST0 are driven by a power-on, or user, reset circuit.



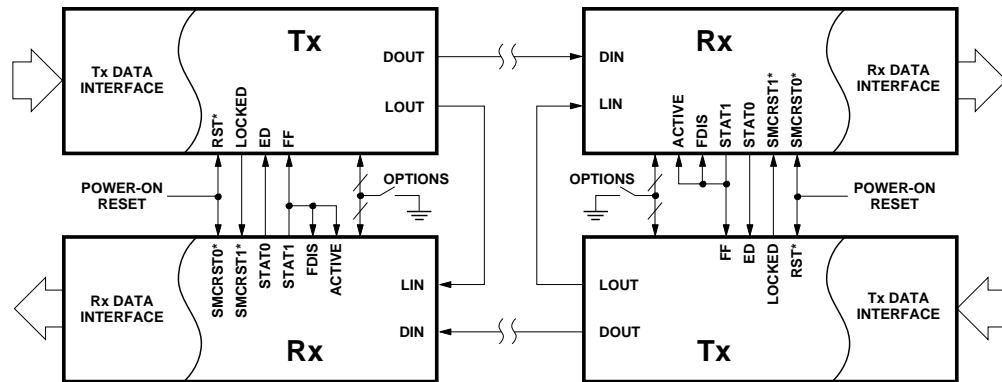

Figure 16. Full Duplex Configuration.

## Appendix II: Link Configuration Examples

This section shows some application examples using the HDMP-1012/1014 chipset. Refer to *I/O Definition* for detailed circuit-level interconnection.

This guide is intended to aid the user in designing G-LINK into a system. It provides the necessary details of getting the system up, without the detailed description of the inner circuitry of the chip set.

The first section is a description of the various configurations for duplex and simplex operation. The second section describes the interface to both single frame and double frame mode. Following that is a section on the integrating capacitor and power supply bypassing recommendations. Next is a guide to the various types of electrical I/O connections. The final section is a discussion on TTL translations

and the use of a single positive supply. Also included is a list of the various options and their definitions.

### Duplex/Simplex Configurations

The following describes the common setups for the link. In all cases, the DIN and LIN are differential high speed lines, and unused leads should be terminated with  $50 \Omega$  AC coupled to ground. Since the data stream has no DC component, a coupling cap of  $0.1 \mu\text{F}$  is recommended for the DIN and LIN inputs.

#### Full Duplex

Figure 16 shows HDMP-1012/1014 in a full duplex configuration connecting two bidirectional (parallel) buses. Each end of the link has a Tx and RX pair. The receiver's state machine outputs (STAT0 and STAT1) are used to control the status of the link. Various options such as 16/20 bit

mode (M20SEL) and speed selections (DIV0, DIV1) are grouped together under the label 'options'. A power-on reset is available to the user to reset the link during startup

Since the outputs STAT0 and STAT1 are ECL levels, they can be tied directly to the pins shown. When the Tx has acquired lock to the incoming STRBIN at the frame rate, the LOCKED pin is activated, which enables the Rx. At this state, both STAT0 and STAT1 are low, forcing the Tx to send FF0, which is a square wave pattern used by the remote Rx to acquire frame lock. When the local Rx has acquire frame lock, STAT1 is set high to first turn off its own frequency detector (FDIS), then sets itself to active mode (ACTIVE), and tells the local Tx to send FF1 to signal the remote Rx that the local pair is ready. Likewise, when the remote pair is ready, the local Rx will

receive FF1, causing STAT0 to go high, which asserts the enable data (ED) pin on the Tx. The ED signal is retimed to signify to the host that the Tx is ready to send data (RFD). Other configurations for duplex mode are also possible with external user-defined state machines. Simplex operation using G-LINK is also possible. The following sections discuss three different types of simplex configurations.

**Simplex Method I. Simplex with Low-Speed Return Path**

Low-speed lines are used in the simplex method of Figure 17a. The remote Rx controls the states of both the Rx and the local Tx using these low speed lines. This is ideal for cases where these non-critical lines are available. Again, a power on reset is available to the user. This connection between the Tx and Rx is identical to one side of the duplex configuration.

When the Tx is locked, the Rx is enabled via the LOCKED line. The Rx's STAT0 and STAT1 outputs are low, causing the local Tx to send FF0. When the Rx is frame locked, STAT1 is raised, which disables its frequency detector, sets itself to active mode, and tells Tx to send FF1. Upon receiving FF1 from the Tx, the Rx's STAT0 line is raised, which enables the Tx (ED) for data transmission. If desired, the Rx reset pin (SMCRST1) can be tied high, and

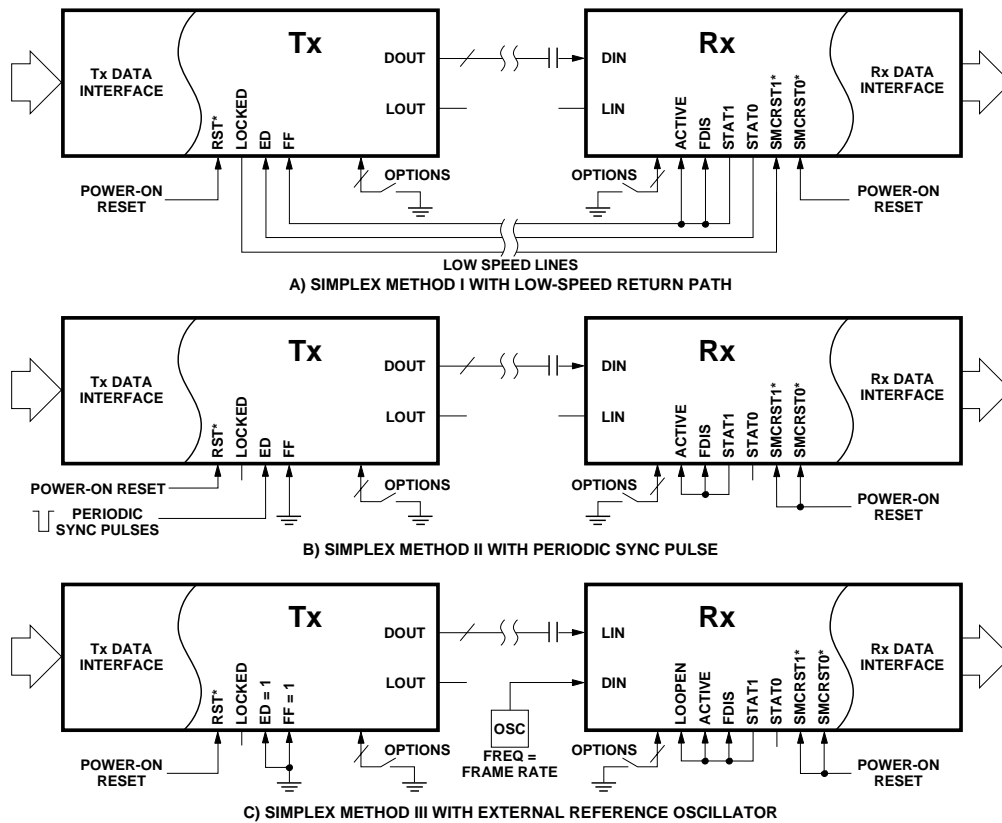

Figure 17: Simplex Configurations.

the LOCKED line can be eliminated.

### **Simplex Method II. Simplex with Periodic Sync Pulse.**

Another configuration of simplex operation is shown in Figure 17b. For frame lock, the Rx normally relies on either FF0 or FF1. In this example, the fill frame FF of the Tx is forced high with a connection to ground, and the enable data pin ED is pulsed periodically to force the Tx to send FF1. During this pulse, however, the link is not available for data transmission.

The pulse width applied to ED should be long enough for the Rx to acquire lock. The typical Rx lock-up time is around 2.5 mS for the high frequency band, thus a 5 mS pulse is adequate in this case. For other bands, longer pulses are required. Typical lock-up times for all four data rate ranges can be found in the table *Typical Lock-Up Time* at the front of the data sheet. Note that these lock-up times assume a 0.1  $\mu$ F integrating capacitor is being used on the PLL. Refer to the section on *Supply Bypassing and Integrator Capacitor* for more details. After G-LINK is locked, ED needs to go low only as often as needed to ensure that the link is locked. Lock can be lost if the serial line is broken, or if two consecutive frame errors are detected by the receiver's state machine. The length of time between ED pulses will determine how long the user needs to wait before lock is re-established.

### **Simplex Method III: Simplex with Reference Oscillator**

A third configuration for simplex operation is shown in Figure 17c. The high-speed serial line is brought into the receiver through the LIN input, and a reference clock at the frame rate is connected to the DIN input.

The Rx uses the reference clock for frequency acquisition. Upon frequency lock, STAT1 goes high, and sets the detector from frequency to phase detection mode through FDIS. At the same time, it switches the input from the reference clock to the data stream. Since the relative phase of the reference clock to that of the data stream is random, the phase detector will lock onto a random transition in the data stream. Errors are detected if the phase lock is not locked to the master transition. If two consecutive errors occur, the STAT1 line is forced low, and the state machine switches the receiver back to the reference oscillator. This process is repeated until the master transition is found, and an error-free condition exists. Because of the nature of this hunting process, it is possible for a static code to emulate the master transition. Therefore, it is recommended that the flag bit be reserved for error detection. With FLAGSEL disabled, the flag bit is toggled internally by the Tx, and the Rx uses this strict alternation to detect errors, thus making the link much more reliable.

The lock up time in this simplex configuration is dependent on the frequency match between the two local oscillators. This method

relies on a slight difference between the two frequencies in order to guarantee a lock within a reasonable time. In theory, a perfect match could result in no lock due by causing the receiver to consistently try and lock at the same non-master transition point in the incoming frames.

Fortunately there is no such thing as a perfect match in the real world. It is recommended to select crystal oscillators between 0.1% to 0.001% matching.

The above method uses the LIN line as the high-speed serial data line. This works well and is simple to implement, but it doesn't take advantage of the coaxial equalizer on the DIN line. Adding an external ECL inverter to the Loop Back Control (LOOPEN) pin allows the reference oscillator to be injected into LIN and the serial data line (DIN) to be used as the high-speed data line. If the coaxial equalizer is needed in the DIN path, DIN and LIN inputs can be interchanged with an external ECL inverter before LOOPEN.

### **Data Interface for Single/Double Frame Mode.**

G-LINK is designed to work with single frame or double frame modes, in either 16 or 20 bits wide per frame. An extra flag bit is available with FLAGSEL and it is used to signify the first or second frames in double-frame mode. The 16/20 frame width option is selected with the M20SEL pin. In this discussion, a 20 bit width is assumed. In both single and double frame modes, the data frame (D0-D19), flag bit (FLAG), and the data/control word available pins (DAV\*, CAV\*), must appear before the setup time  $t_s$ , and remain valid for the hold time  $t_h$ . Refer to *HDMP-1012 Tx*

**Timing.** Since the PLL of the Tx is designed with a very high-gain frequency/phase detector, the relative alignment of the internal clock and STRBIN is very tight, and is insensitive to temperature and other variations. The observed external changes are due mainly to variations in the buffers, which are relatively small. For convenience, the setup and hold times are referenced back to the user-supplied clock, STRBIN. The actual sampling clock is slightly advanced relative to STRBIN due to internal delays, and the hold time is typically negative.

The user has to make sure that M20SEL, FLAGSEL, DIV0, and DIV1 have the same setting on both Tx and Rx. The word width of the parallel data from the host can be either 16 bits if M20SEL = 0, or 20 bits if M20SEL = 1. Also, the FLAG bit can be used as an additional bit by setting

FLAGSEL=1. In the last case, the parallel data word width is either 17 bits or 21 bits. The local loopback test can be enabled by setting LOOPEN high.

**Single Frame Mode (MDFSEL=0)**

A block diagram showing the single-frame mode data interface for both the Tx and Rx, and their associated timing diagrams are shown in Figure xxx.

In the Tx side, the expected frequency of the input clock STRBIN is the bit rate of the data frame. In this case, the setup and hold times are referenced to the rising edge of STRBIN. The internal clock is buffered to form STRBOUT which appears with a delay of  $T_{strb}$  after STRBIN.

In the Rx side, the data frame, flag bit, CAV\*, DAV\*, LINKRDY, and ERROR appear with a delay of  $t_{d1}$  after the falling edge of STRBOUT. The state machine

outputs STAT0 and STAT1 appear with a delay of  $t_{d2}$ .

**Double Frame Mode (MDFSEL=1)**

A block diagram showing the double-frame mode data interface for both the Tx and Rx, and their associated timing diagrams are shown in Figure 17. This configuration works best if the duty cycle of STRBIN is 50%.

In the Tx side, the expected frequency is 1/2 of the combined frame period. This combined frame, D0-D19, is formed by interlacing the two frames C0-C19 and C20-C39 with an external 2:1 multiplexer. The Tx locks onto STRBIN, which has the same frequency as the bit rate of C0-C39, and with an internal frequency doubler, generates the sampling clock to latch in D0-D19, DAV\*, CAV\*, and FLAG. STRBIN is also used to toggle the 2:1 multiplexer, and is fed into

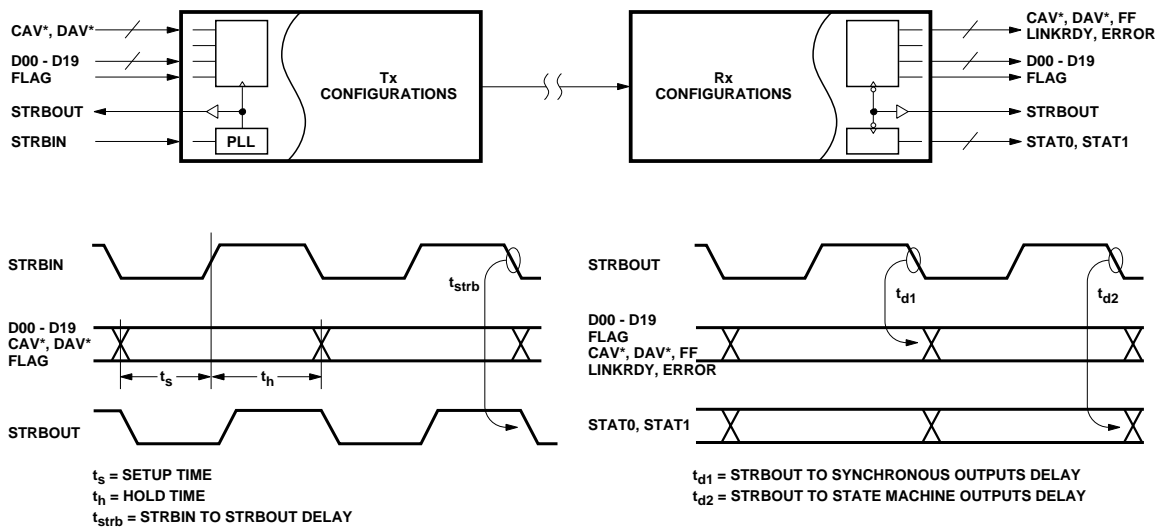

Figure 18: Tx and Rx Data Interface for Single Frame Mode (MDFSEL=0).

the flag input to signify the two frames. The setup and hold times are referenced to 1/2 frame period of D0-D19, or 90 deg, from the edges of STRBIN. The multiplexer delay,  $t_{mux}$ , should be considered for timing margins. The STRBOUT is derived from the internal sampling clock, and thus has a frequency double that of STRBIN. The falling edge of STRBOUT appears after the rising and falling edges of STRBIN after a delay of  $T_{strb}$ . Other interlacing techniques can also be achieved with edge-triggered latches for improved timing margins.

In the Rx side, the frame D0-D19 are demultiplexed back to the original C0-C19, and C20-C39 frames with the use of external edge-triggered flip-flops. The

toggle clock of the flip-flops, RCLK, is derived by the state of the FLAG bit. RCLK toggle with the rising edge of STRBOUT with a delay of  $t_{da}$ . The two frames appear with the rising and falling edges of RCLK with a delay of  $t_{db}$ . All of the synchronous outputs and state machine outputs appear after the falling edge of STRBOUT with delays of  $t_{d1}$  and  $t_{d2}$  respectively.

The lower frame of C0-C19 can be delayed further with additional latches so that both C0-C19 and C20-C39 frames are synchronous.

### Supply Bypassing and Integrator Capacitor

Figure 20 shows the location of the PLL integrator capacitors, power supply capacitors and

required grounding for the Tx and Rx chips.

### Integrating Capacitor

The integrating capacitors (C2) are required by both the Tx and Rx to function properly. These caps are used by the PLL for frequency and phase lock and directly set the stability and lockup times. The designed value of C2 is 0.1  $\mu$ F, with a tolerance of  $\pm 10\%$ . The internal charging currents are scaled with the DIV0 and DIV1 settings such that the same capacitor value works with all four frequency bands. Larger values of C2 improve jitter performance, but extend the lockup times.

### Power Supply Bypassing and Grounding

The G-LINK chip set has been tested to work well with a single

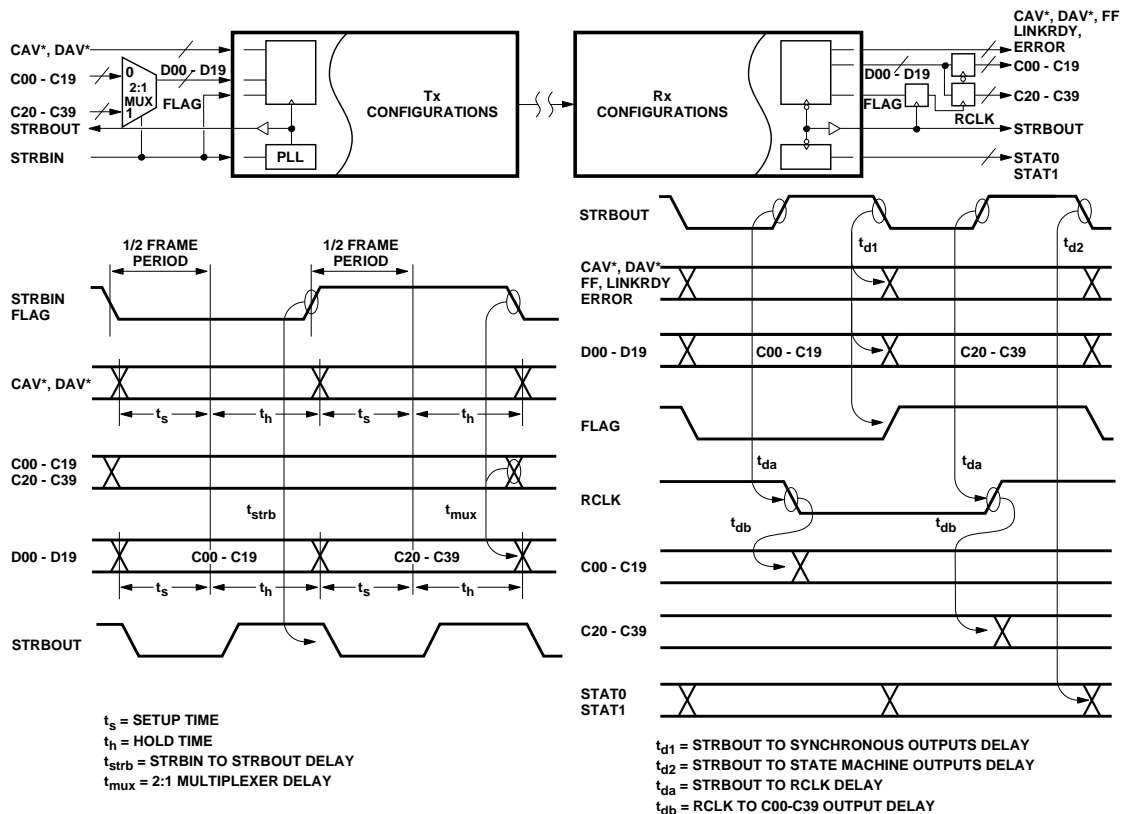

Figure 19. Transmitter and Receiver Data Interface and Timing for Double Frame Mode (MDFSEL=0).

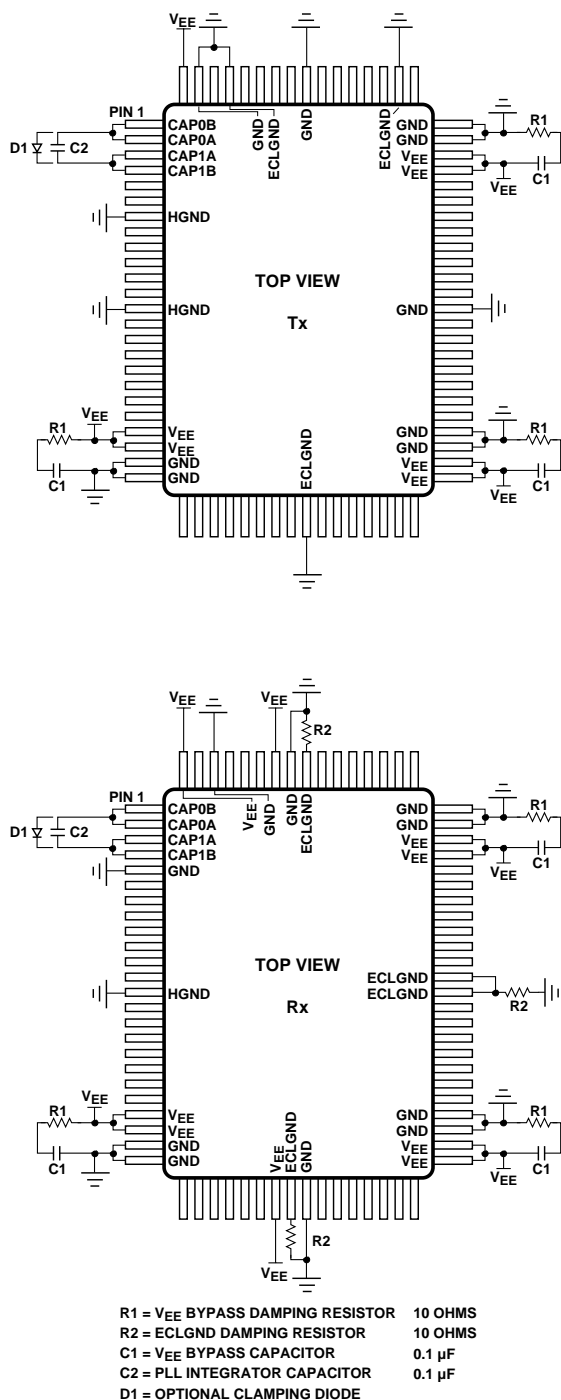

Figure 20. Power Supply Bypass.

ground plane, assuming that it is a fairly clean ground plane. Thus, all of the separate grounds (HGND, GND, and ECLGND) can be connected onto this plane. The bypassing of VEE to ground should be accomplished with a capacitor (C1) of 0.1 μF and a series resistor (R1) of 10 Ω. This series RC network prevents possible oscillations caused by package, capacitor, and layout parasitics. The Rx ECLGND leads are grounded using R2. These 10 Ω resistors reduce excessive ringing caused by current spikes generated by the parasitic inductance in the ECLGND leads. This effect is more pronounced in the receiver because of its multiple ECL outputs. The ECLGND pins of the Tx are simply grounded.

In some instances, if the VCO of either the Tx or the Rx are at the extreme high end, the frequency of STRBOUT exceeds the maximum frequency allowed by the hosts. In this case, it is recommended that a diode clamp, D1, be used across the integrating cap C2, such that the upper frequency is limited. The typical swing of C2 is ± 0.8 volts, and thus, the clamping diode should have a turn-on voltage below 0.8 V, such as with germanium or schottky diodes. This will vary with each application. This diode will also aid the Tx and Rx in the initial frequency lock-in process.

### Electrical Connections

The electrical I/Os for both the Tx and Rx are shown in Figures 21-23. The data sheet uses the prefix, I and O, on the logic type in order to identify input and output lines respectively. Additional information on pin names and their functions can be

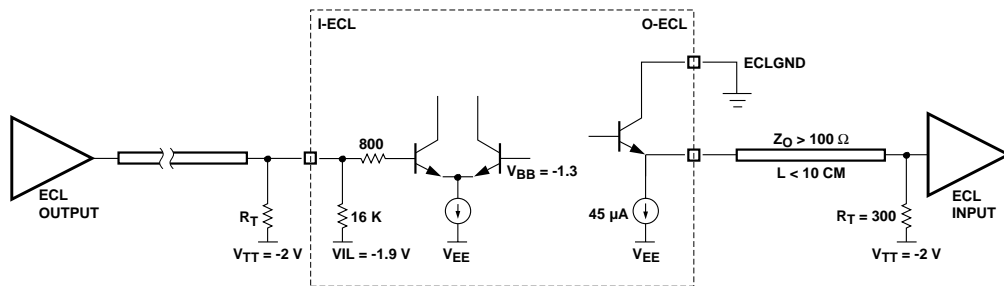

Figure 21. I-ECL and O-ECL Simplified Circuit Schematic.

found in the data sheet under *Tx / Rx I/O Definitions*.

### I-ECL and O-ECL

These I/O are designed to interface directly to ECL-100K family. A simplified schematic diagram of I/O cell is shown in Figure 21. Many of the ECL interface theories and techniques can be found in commercial ECL data books.

The I-ECL inputs have internal pull down resistors, such that if left opened, the logic level will float low. Also, the inputs can be tied to ground directly to yield a logic high. These inputs can be driven from standard ECL buffers, using conventional termination techniques. Series terminations at the source can also be used.

In most cases, the unconnected I-ECL input will suffice for a logic low. However, some I-ECL pins with adjacent high speed lines, such as the *TCLKSEL* pin in the *Rx*, may be affected by crosstalk dependent on the trace separations in the board layout. In this case, all pins with logic lows

can be tied together and bypassed to ground with a 0.1  $\mu\text{F}$  capacitor.

The O-ECL can each drive a 50  $\Omega$  line terminated with 50  $\Omega$  to  $V_{tt} = -2\text{ V}$ . However, because of the multiple outputs, driving all lines into 50  $\Omega$  loads will cause excessive power dissipation and may lead to undesirable current spikes in the power and ground planes. Therefore, it is recommended that the termination resistor, which sets the output bias current, be limited to 300  $\Omega$ . To minimize reflections, it is desirable to match the characteristic impedance of the line to the termination resistance. But because of PC board limitations, realistic values of 100  $\Omega$  transmission lines are more achievable. With 100  $\Omega$  lines, it is recommended that the maximum distance of the transmission lines do not exceed 10 cm.

The preferred termination resistors are individual surface-mount resistors, commonly connected to  $V_{tt} = -2\text{ V}$  which is properly bypassed to ground. Resistor packs such as SIPs are

acceptable, but will reduce noise margins due to extra parasitics.

Each of the O-ECL outputs has a small trickle current which turns on the output emitter follower such that DC logic levels would appear without external pull-down terminations. This feature is useful for testing and system debugging.

### High Speed Interface: I-H50 & O-BLL

The simplified schematic diagrams of I-H50 and O-BLL is shown in Figure 22. The I-H50 input cell has internal 50  $\Omega$  resistors built into the differential input lines. The termination is connected via HGND which isolates the high speed ground currents from the internal grounds. The DC level for the inputs is at 0 V. Since all of the high speed inputs into G-LINK do not have a DC component, it is recommended that I-H50 inputs be AC coupled with a 0.1  $\mu\text{F}$  capacitor. It is also recommended that the unused differential inputs be terminated with 50  $\Omega$ . The O-BLL output cell is designed to

deliver ECL swings directly into  $50\ \Omega$ . The output impedance is matched to  $50\ \Omega$  with a VSWR of less than 2:1 to above 2 GHz. This output is ideal for driving the I-H50 input through a  $50\ \Omega$  cable and a  $0.1\ \mu\text{F}$  coupling capacitor. The  $150\ \Omega$  shunt resistor to ground improves internal DC bias of the O-BLL differential output circuit. The O-BLL driver can also be connected directly into a high speed  $50\ \Omega$  oscilloscope. For optimum performance, both output should see the same impedance. It is necessary that all used O-BLL outputs be terminated into  $50\ \Omega$ . Figure 23 shows various methods of

interfacing O-BLL to I-H50 and standard ECL logic.

### TTL and Positive 5 V Operation

Many applications require the I/Os to interface to the standard TTL logic family. Such TTL/ECL translators are available in the industry from various semiconductor manufacturers. This works well, but requires two power supplies since the system is supporting two different logic families. This technique is preferred, since it is easier to keep a single clean ground plane.

Although G-LINK has been designed to work with conventional ECL negative supply, a single positive supply can also be used. This basically replaces the traditional ground and Vee planes with the Vcc and ground planes. Also, the termination plane Vtt is shifted up to +3 V. In theory, since voltages are all relative, there should be no difference. In practice, however, the differences lie in how well the Vcc plane is bypassed to ground, since all of the I/Os are referenced to this plane. It is therefore necessary to separate any TTL or CMOS Vcc to this chip set, so that the cleanest Vcc plane can be achieved.

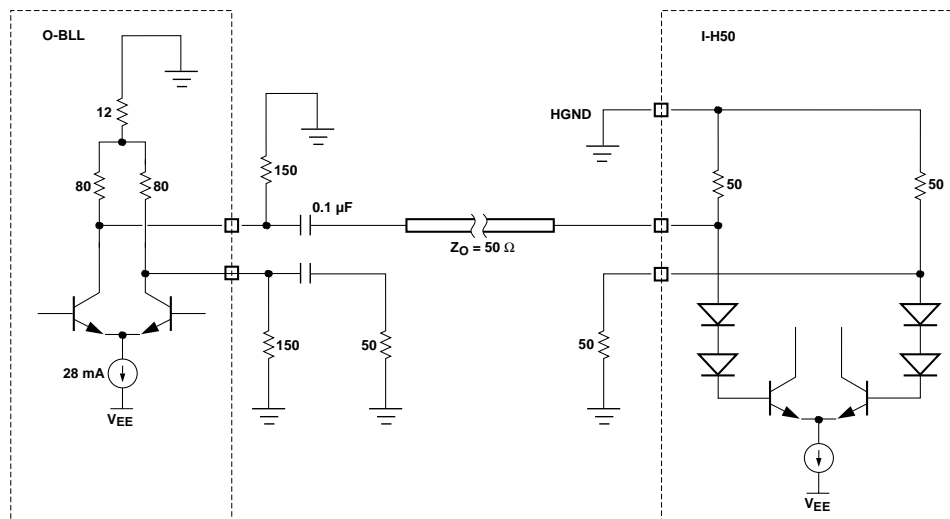

Figure 22. I-H50 and O-BLL Simplified Circuit Schematic.



Likewise, the V<sub>tt</sub> plane must also be bypassed equally well.

In the positive 5 V supply configuration, the logic outputs are in the PECL (positive ECL) states. Commercial translation chips are available which will translate PECL between TTL and CMOS.

### Mode Options

The GLink has several option pins which set the modes of operation. Common to both the Tx and the Rx are M20SEL, DIV0, and DIV1, FLAGSEL, and LOOPEN. Local to the Tx are MDFSEL, EHCLKSEL, and HCLKON. While local to the Rx are EQEN and TCLKSEL. These pins are all I-ECL, and can be set as described below.

M20SEL = 0/1 sets the width of the frame to 16/20 bits.

DIV1 / DIV0 = set the frequency bands of operation. Refer to the *Setting the Operating Data Rate Range* section for frequency band selection. It is recommended that applications near the ends of the bands have jumpers for DIV0 and DIV1 inputs, so that the board can accommodate possible lot-to-lot band variations over the life of the board design.

FLAGSEL = 0/1 selects either the flag bit is reserved for error detection by the link, or as an extra bit available for the user.

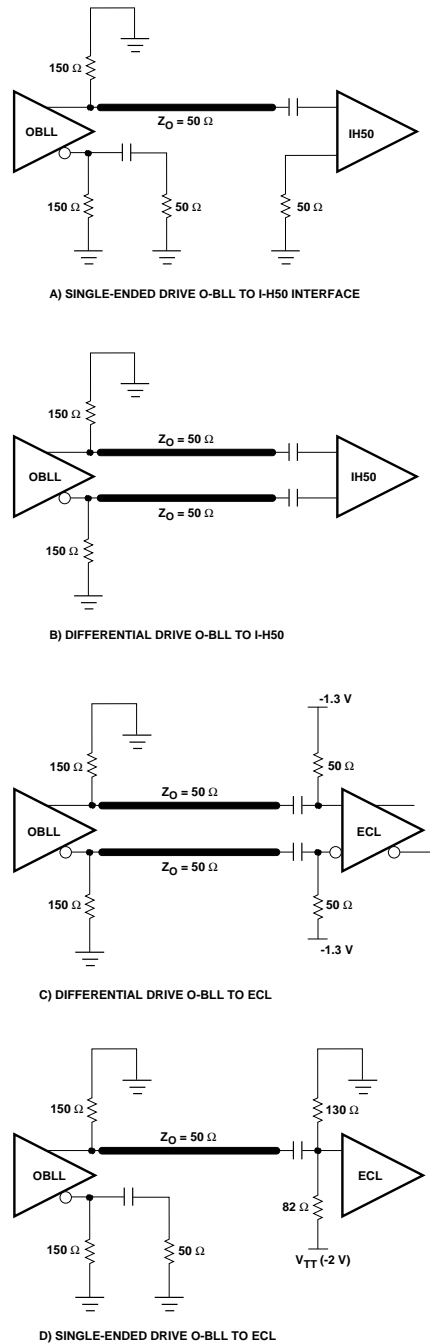

Figure 23: Methods of Interfacing O-BLL and I-H50.

LOOPEN = 0/1 selects either the normal data or the loop channels the I/O.

MDFSEL = 0/1 selects the Tx single or double frame modes.

ECHKSEL = 0/1 selects either to lock onto a frame-rate clock at STRBIN or to use this clock as the high speed clock and bypass the PLL in the Tx. This input is used mainly for testing, and should be normally set low.

HCLKON = 0/1 turns on the high speed serial clock outputs of the Tx. This option was added to conserve power.

EQEN = 0/1 disables or enables the data equalizer in the Rx for cable applications.

TCLKSEL = 0/1 selects the clock source from either be derived from the serial data stream or from the TCLK inputs for the Rx. This input is for testing only, and should normally be set low.