

# BGW200 Low-power WLAN SiP

Optimized for low-power mobile applications, this complete, single-package 802.11b solution combines a baseband/MAC, RF transceiver, and power amplifier into an ultra-small (150 mm<sup>2</sup>) package. It delivers the industry's lowest power consumption in standby mode and supports coexistence with Bluetooth® solutions.



## Key features

- Advanced, single-package WLAN SiP optimized for mobile handheld devices
  - No RF-critical design required
  - Low total cost of ownership
- Lowest power consumption in standby mode: < 2 mW (typ)
- Ultra-small form factor
  - Low-profile 68-pin HVQFN-like SiP package (10 x 15 x 1.3 mm)
  - Only three external components for entire solution
- “No Host Load” design delivers easy integration and longer battery life
  - Host processor sleeps while BGW200 processes beacons
  - BGW200 wakes the host processor only upon data packet arrival
- Co-exists with Bluetooth 1.1 and 1.2
- Complete software drivers, utility, and diagnostic tools

## Applications

- Smartphones, cellular phones, VoIP wireless phones
- PDAs, handheld computing devices, WLAN adapter cards (Secure Digital)
- Portable audio/video devices, MP3 players
- Other handhelds and electronic devices for wireless digital, audio, multi-media, and telephony

## Complete, single-package 802.11b solution for mobile handheld devices

### Semiconductors

The BGW200 is a complete, low-power 802.11b Wireless LAN (WLAN) System-in-a-Package (SiP) solution optimized for battery-powered handheld devices. It enables consumers to connect to the growing number of WLAN networks in offices, homes, and public places. It also allows service providers to increase their network reach and customer base, enabling complementary data and voice services across cellular/PCS and WLAN networks. Coexistence support for Bluetooth 1.1 and 1.2 enables seamless integration with Philips Bluetooth solutions.

The SiP format, with its complete system functionality, delivers quicker design cycles, lower risk, simplified manufacturing, and a reduced bill of materials. The single-package format also simplifies assembly and testing, and reduces yield losses. The SiP delivers a complete, fully tested implementation of 802.11b functionality, so development teams can focus their energy on innovative product design instead of solving complex issues related to RF layout.

### Ultra-small footprint, ultra-low power consumption

The BGW200 uses a single, 68-pin HVQFN-like package that measures only 10 x 15 x 1.3 mm. The entire 802.11b solution requires only three external components and uses less than 180 mm<sup>2</sup> of circuit board area.

The BGW200 incorporates several features that decrease power consumption. There is an integrated ARM7 processor, 1.25 Mbytes of SRAM, 256 Kbytes of ROM, optimized host interfaces (SDIO/SPI), and integrated power management hardware/software algorithms. The result is the lowest standby power consumption in the industry (less than 2 mW).

### Superior “No Host Load” Architecture

The BGW200 is designed to place no load on the host processor, so mobile devices can integrate WLAN functionality without compromising application performance or battery life. The BGW200 only interfaces

# PHILIPS

# BGW200

## Low-power 802.11b SiP with baseband/MAC and RF transceiver for mobile handhelds



with the host processor when a valid data packet is received. So the host processor is allowed to sleep while the BGW200 independently processes 802.11 beacons.

The MAC protocol runs on an embedded ARM7 processor, for zero overhead on the host processor. An instruction prefetch unit enhances the performance of the ARM7. To support new MAC protocol features, the BGW200 is also designed to support firmware upgrades.

### Bluetooth coexistence

The BGW200 is designed to support collaborative coexistence between 802.11 and Bluetooth 1.1 and 1.2. A dedicated software and hardware interface implements Packet Traffic Arbitration (PTA) with voice priority between the BGW200 and the Bluetooth system. An auto shutdown feature ensures that Bluetooth voice takes priority over other signals and there is special support for burst and fragmented frames. Bluetooth 1.2 enhances coexistence further, by adding independent Adaptive Frequency Hopping (AFH) capability. The Philips BGB20x family of Bluetooth SiPs is designed to interface and coexist seamlessly with the BGW200.

### Supports latest QoS and security standards

Advanced hardware and software algorithms, along with Wi-Fi Multimedia Extensions (WME), provide advanced Quality of Service (QoS) functions. This lets the BGW200 support real-time applications like VoIP and non-real-time applications like email and web surfing. The BGW200 is also designed to support the upcoming 802.11e standard.

The BGW200 has advanced security features, including 40- and 128-bit WEP, WPA, CCX (Cisco Security), TKIP, and AES. The SiP is also designed to support the upcoming 802.11i extension.

### Advanced RF subsystem

The integrated RF transceiver supports transmit output power control from +8 to +18 dBm at the antenna port – enabling optimal range, throughput, and power consumption. The integrated RF transceiver uses a direct conversion radio architecture that minimizes external components and eliminates the IF filter. For additional component reduction, the integrated PA is internally matched to the ZIF radio. In addition to the radio transceiver and power amplifier, the BGW200 also integrates an Rx/Tx diversity switch, bandpass filter, balun, power supply decoupling, and other passive components.

### Reference designs and eval kits

Reference design software drivers support PocketPC™ and Linux™ operating systems. Drivers for Palm™ and Symbian™ are in development. The BGW200 is backed by a complete set of software utility and diagnostic tools, and is available in evaluation kits.

Table 1

Frequency Bands	2.4 to 2.5 GHz
Modulations	DBPSK, DQPSK, CCK (DSSS)
Data Rates	1, 2, 5.5, 11 Mbps
SiP Power Consumption (typical)	Tx: 731 mW @ 15 dBm Rx: 415 mW Standby: < 2 mW Sleep Mode: 0.2 mW

Table 2

Description	Size	Part Number
Low-power 802.11b SiP	10 x 15 x 1.3 mm	BGW200

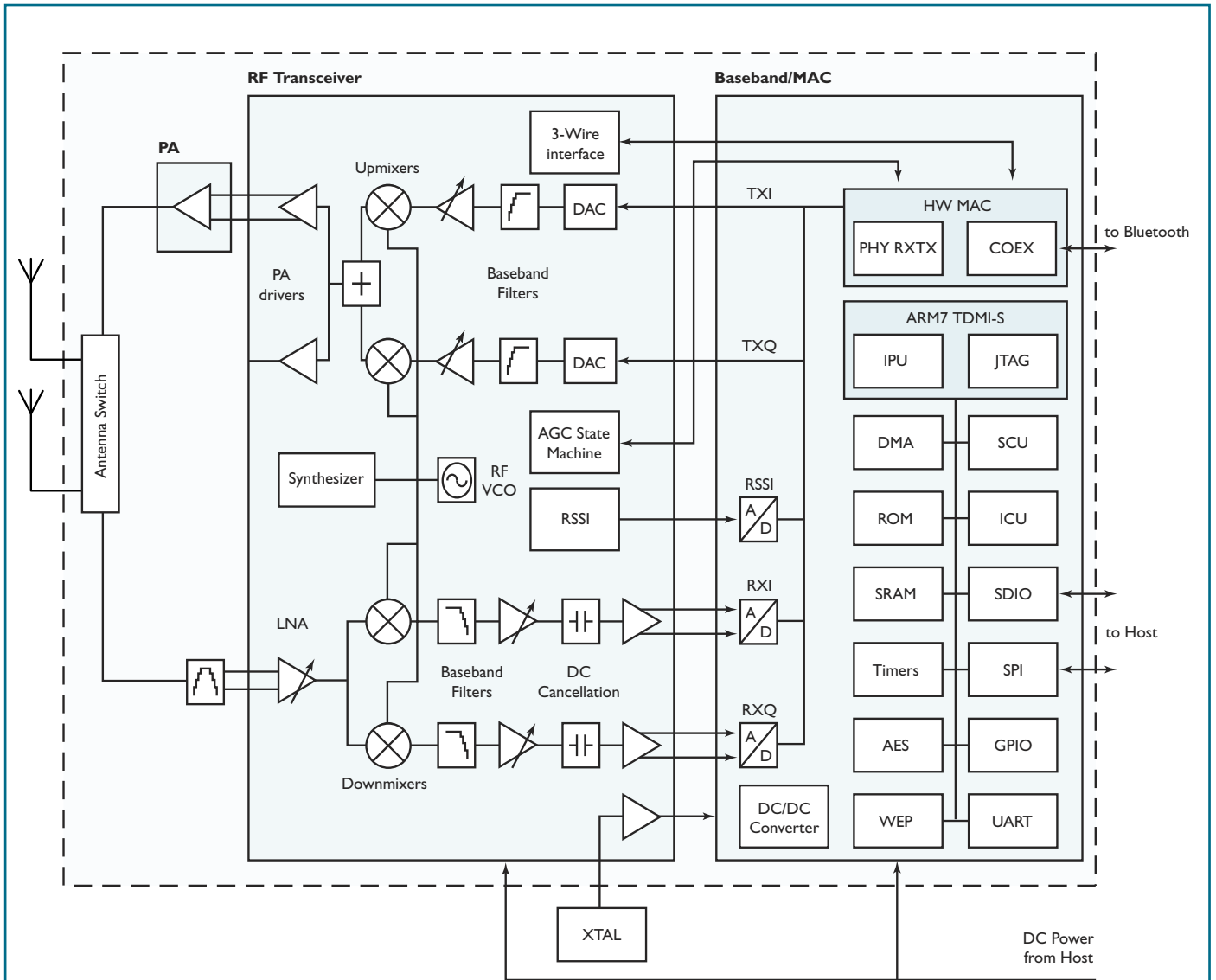

**List of abbreviations**

AES Advanced Encryption Standard  
 COEX Coexistence  
 ICU Interrupt Control Unit  
 IPU Instruction Pre-fetch Unit  
 JTAG Joint Test Action Group  
 MAC Medium Access Control

PHY Physical Layer  
 RSSI Receive Signal Strength Indicator  
 SCU System Control Unit  
 SDIO Secure Digital Input Output  
 SPI Serial Peripheral Interface  
 WEP Wired Equivalent Privacy

BGW200 functional block diagram

# BGW200

Low-power 802.11b SiP with baseband/MAC and RF transceiver for mobile handhelds



## Philips Semiconductors

Philips Semiconductors is a worldwide company with over 100 sales offices in more than 50 countries. For a complete up-to-date list of our sales offices please e-mail [sales.addresses@www.semiconductors.philips.com](mailto:sales.addresses@www.semiconductors.philips.com). A complete list will be sent to you automatically. You can also visit our website <http://www.semiconductors.philips.com/sales>.

© Koninklijke Philips Electronics N.V. 2004

SCL 76

All rights reserved. Reproduction in whole or in part is prohibited without the prior written consent of the copyright owner. The information presented in this document does not form part of any quotation or contract, is believed to be accurate and reliable and may be changed without notice. No liability will be accepted by the publisher for any consequence of its use. Publication thereof does not convey nor imply any license under patent or other industrial or intellectual property rights.



Date of release: May 2004  
document order number: 9397-750-13342

Published in USA