

## 1 M x 4-Bit Dynamic RAM Low Power 1 M x 4-Bit Dynamic RAM

HYB 514400BJ/BT-60/-70/-80  
HYB 514400BJL/BTL-60/-70/-80

### Advanced Information

- 1 048 576 words by 4-bit organization
- 0 to 70 °C operating temperature
- Fast access and cycle time
  - RAS access time:
    - 60 ns (-60 version)
    - 70 ns (-70 version)
    - 80 ns (-80 version)
  - CAS access time:
    - 20 ns
  - Cycle time:
    - 110 ns (-60 version)
    - 130 ns (-70 version)
    - 150 ns (-80 version)
- Fast page mode cycle time
  - 45 ns (-60 version)
  - 45 ns (-70 version)
  - 50 ns (-80 version)
- Single + 5 V ( $\pm 10\%$ ) supply with a built-in  $V_{bb}$  generator
- Low power dissipation
  - max. 605 mW active (-60 version)
  - max. 550 mW active (-70 version)
  - max. 468 mW active (-80 version)
- Standby power dissipation:
  - 11 mW standby standby (TTL)
  - 5.5 mW max.standby (CMOS)
  - 1.1 mW max.standby (CMOS) for Low Power Version
- Output unlatched at cycle end allows two-dimensional chip selection
- Read, write, read-modify write, CAS-before-RAS refresh, RAS-only refresh, hidden refresh, fast page mode capability and test mode capability
- All inputs and outputs TTL-compatible
- 1024 refresh cycles / 16 ms
- 1024 refresh cycles / 128 ms Low Power Version only
- Plastic Packages: P-SOJ-26/20-5 and P-TSOPII-26/20-1 with 300 mil width

The HYB 514400B is the new generation dynamic RAM organized as 1 048 576 words by 4-bit. The HYB 514400B utilizes CMOS silicon gate process as well as advances circuit techniques to provide wide operation margins, both internally and for the system user. Multiplexed address inputs permit the HYB 514400B to be packed in a standard plastic P-SOPJ-26/20 or P-TSOPII-26/20 package. This package size provides high system bit densities and is compatible with commonly used automatic testing and insertion equipment. System oriented feature include single + 5 V (± 10 %) power supply, direct interfacing with high performance logic device families such as Schottky TTL.

### Ordering Information

Type	Ordering Code	Package	Descriptions
HYB 514400BJ-60	Q67100-Q756	P-SOJ-26/20-5	DRAM (access time 60 ns)
HYB 514400BJ-70	Q67100-Q757	P-SOJ-26/20-5	DRAM (access time 70 ns)
HYB 514400BJ-80	Q67100-Q758	P-SOJ-26/20-5	DRAM (access time 80 ns)
HYB 514400BJL-60	on request	P-SOJ-26/20-5	DRAM (access time 60 ns)
HYB 514400BJL-70	Q67100-Q762	P-SOJ-26/20-5	DRAM (access time 70 ns)
HYB 514400BJL-80	Q67100-Q764	P-SOJ-26/20-5	DRAM (access time 80 ns)
HYB 514400BT-60	Q67100-Q749	P-TSOPII-26/20-1	DRAM (access time 60 ns)
HYB 514400BT-70	Q67100-Q750	P-TSOPII-26/20-1	DRAM (access time 70 ns)
HYB 514400BT-80	Q67100-Q751	P-TSOPII-26/20-1	DRAM (access time 80 ns)
HYB 514400BTL-60	on request	P-TSOPII-26/20-1	DRAM (access time 60 ns)
HYB 514400BTL-70	on request	P-TSOPII-26/20-1	DRAM (access time 70 ns)
HYB 514400BTL-80	on request	P-TSOPII-26/20-1	DRAM (access time 80 ns)

**P-SOJ-26/20-5**  
**P-TSOPII-26/20-1**

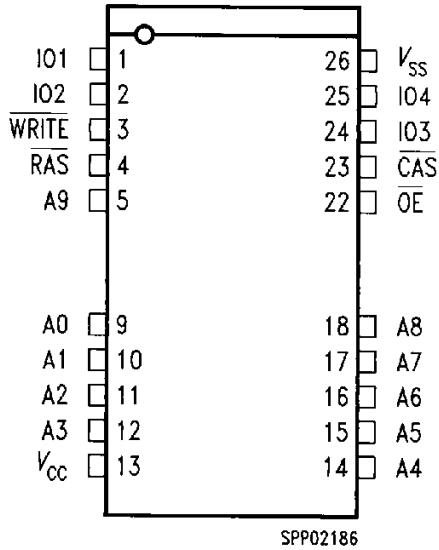

**Pin Configuration**

**Pin Names**

A0-A9	Address Input
$\overline{\text{RAS}}$	Row Address Strobe
$\overline{\text{CAS}}$	Column Address Strobe
$\overline{\text{WE}}$	Read/Write Input
$\overline{\text{OE}}$	Output Enable
IO1 - IO4	Data Input/Output
$V_{\text{CC}}$	Power Supply (+ 5 V)
$V_{\text{SS}}$	Ground (0 V)

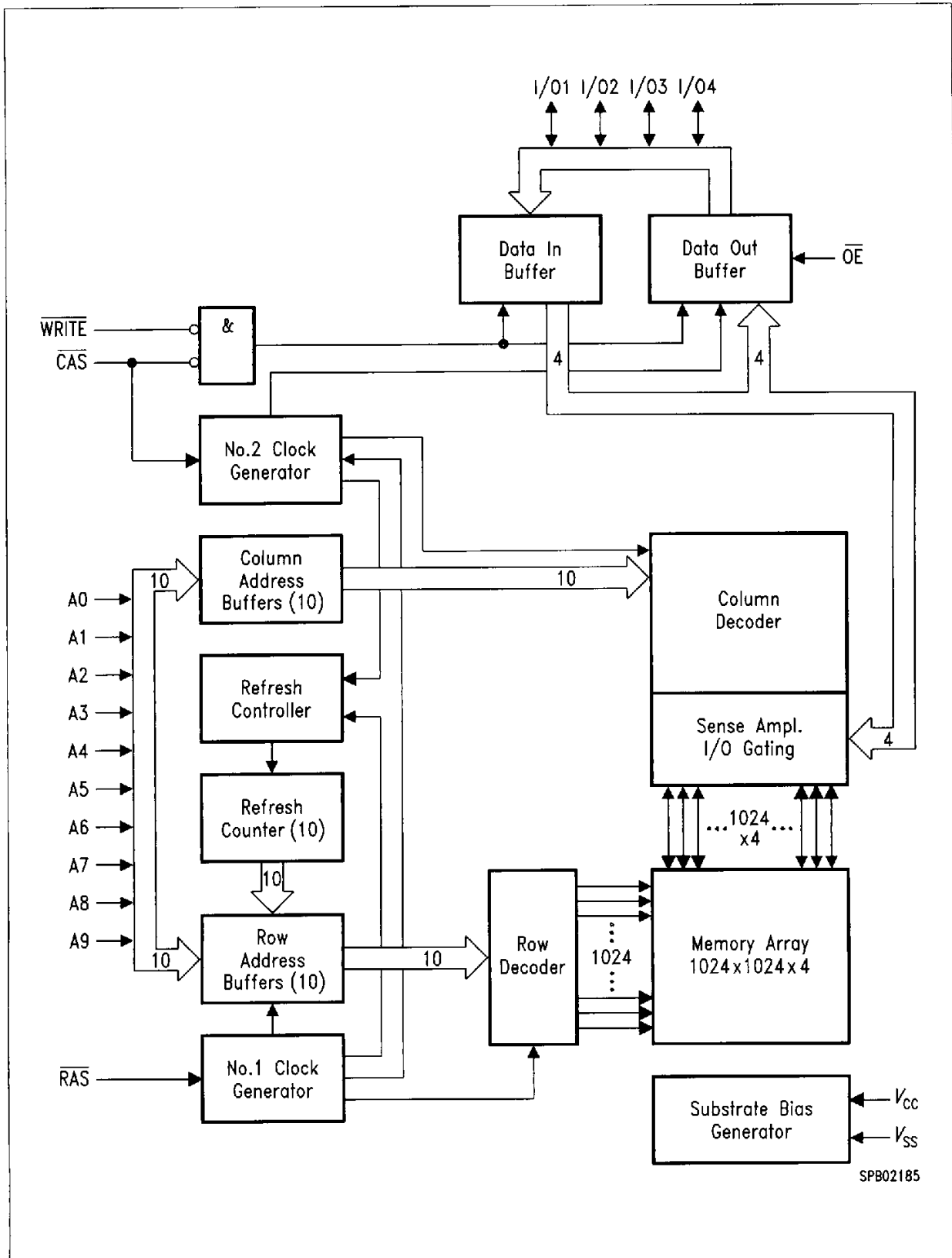

SPB02185

Block Diagram

### Absolute Maximum Ratings

Operating temperature range .....	0 to 70 °C
Storage temperature range.....	- 55 to + 150 °C
Soldering temperature .....	260 °C
Soldering time.....	10 s
Input/output voltage .....	- 1 to + 7 V
Power Supply voltage .....	- 1 to + 7 V
Data out current (short circuit) .....	50 mA

**Note:** Stresses above those listed under "Absolute Maximum Ratings" may cause permanent damage of the device. Exposure to absolute maximum rating conditions for extended periods may affect device reliability.

### DC Characteristics

$T_A = 0$  to  $70$  °C,  $V_{SS} = 0$  V,  $V_{CC} = 5$  V  $\pm$  10 %,  $t_T = 5$  ns

Parameter	Symbol	Limit Values		Unit	Test Condition
		min.	max.		
Input high voltage	$V_{ih}$	2.4	6.5	V	1)
Input low voltage	$V_{il}$	- 1.0	0.8	V	1)
Output high voltage ( $I_{OUT} = - 5$ mA)	$V_{oh}$	2.4	-	V	1)
Output low voltage ( $I_{OUT} = 4.2$ mA)	$V_{ol}$	-	0.4	V	1)
Input leakage current, any input ( $0$ V < $V_{in}$ < 7, all other input = 0 V)	$I_{I(L)}$	- 10	10	$\mu$ A	1)
Output leakage current (DO is disabled, $0 < V_{OUT} < V_{CC}$ )	$I_{o(L)}$	- 10	10	$\mu$ A	1)
Average $V_{CC}$ supply current -60 version -70 version -80 version	$I_{CC1}$	-	110 100 85	mA	2) 3)
Standby $V_{CC}$ supply current (RAS = CAS = $V_{ih}$ )	$I_{CC2}$	-	2	mA	-
Average $V_{CC}$ supply current during RAS-only refresh cycles -60 version -70 version -80 version	$I_{CC3}$	-	110 100 85	mA	2)
Average $V_{CC}$ supply current during fast page mode operation -60 version -70 version -80 version	$I_{CC4}$	-	70 70 60	mA	2) 3)

Notes see page 107.

**DC Characteristics (cont'd)**

$T_A = 0$  to  $70$  °C,  $V_{SS} = 0$  V,  $V_{CC} = 5$  V  $\pm$  10 %,  $t_T = 5$  ns

Parameter	Symbol	Limit Values		Unit	Test Condition
		min.	max.		
Standby $V_{CC}$ supply current (RAS = CAS = $V_{CC} - 0.2$ V)	$I_{CC5}$	–	1	mA	1)
Standby $V_{CC}$ supply current (RAS = CAS = $V_{CC} - 0.2$ V) for Low Power Version	$I_{CC5}$	–	200	$\mu$ A	–
Average $V_{CC}$ supply current during CAS before RAS refresh mode	$I_{CC6}$			mA	2)
-60 version		–	110		
-70 version		–	100		
-80 version		–	85		
For Low Power Version only: Battery backup current (average power supply current in battery backup mode): (CAS = CAS before RAS cycling or 0.2 V, WRITE = $V_{CC} - 0.2$ V or 0.2 V, A0 to A10 = $V_{CC} - 0.2$ V or 0.2 V; DI = $V_{CC} - 0.2$ V or 0.2 V or open, $t_{RC} = 125$ $\mu$ s, $t_{RAS} = t_{RAS\ min} = 1$ $\mu$ s)	$I_{CC7}$	–	300	$\mu$ A	–

Notes see page 107.

AC Characteristics <sup>4)</sup> $T_A = 0$  to  $70$  °C;  $V_{CC} = 5$  V  $\pm$  10 %;  $t_T = 5$  ns

Parameter	Symbol	Limit Values						Unit
		-60		-70		-80		
		min.	max.	min.	max.	min.	max.	
Random read or write time	$t_{RC}$	110	–	130	–	150	–	ns
Read-write cycle time	$t_{RCW}$	165	–	185	–	205	–	ns
Fast page mode cycle time	$t_{PC}$	45	–	45	–	50	–	ns
Fast page mode read/write cycle time	$t_{PRWC}$	100	–	100	–	105	–	ns
Access time from RAS <sup>6) 11)</sup>	$t_{RAC}$	–	60	–	70	–	80	ns
Access time from CAS <sup>6) 11)</sup>	$t_{CAC}$	–	20	–	20	–	20	ns
Access time from column address <sup>6) 12)</sup>	$t_{AA}$	–	30	–	35	–	40	ns
Access time from CAS precharge <sup>6)</sup>	$t_{CPA}$	–	40	–	40	–	45	ns
CAS to output in low-Z <sup>6)</sup>	$t_{CLZ}$	0	–	0	–	0	–	ns
Output buffer turn-off delay from CAS <sup>7)</sup>	$t_{OFF}$	0	20	0	20	0	20	ns
Transition time (rise and fall) <sup>5)</sup>	$t_T$	3	50	3	50	3	50	ns
RAS precharge time	$t_{RP}$	40	–	50	–	60	–	ns
RAS pulse width	$t_{RAS}$	60	10000	70	10000	80	10000	ns
RAS pulse width in fast page mode	$t_{RASP}$	60	200000	70	200000	80	200000	ns
RAS hold time	$t_{RSH}$	20	–	20	–	20	–	ns
CAS hold time	$t_{CSH}$	60	–	70	–	80	–	ns
CAS pulse width	$t_{CAS}$	20	10000	20	10000	20	10000	ns
RAS to CAS delay time <sup>11)</sup>	$t_{RCD}$	20	40	20	50	20	60	ns
RAS to column address delay time <sup>12)</sup>	$t_{RAD}$	15	30	15	35	15	40	ns

Notes see page 107.

AC Characteristics (cont'd)<sup>4)</sup> $T_A = 0$  to  $70$  °C;  $V_{CC} = 5$  V ± 10 %;  $t_f = 5$  ns

Parameter	Symbol	Limit Values						Unit
		-60		-70		-80		
		min.	max.	min.	max.	min.	max.	
CAS to RAS precharge time	$t_{CRP}$	5	–	5	–	10	–	ns
CAS precharge time	$t_{CPN}$	10	–	10	–	10	–	ns
CAS precharge time in fast page mode	$t_{CP}$	10	–	10	–	10	–	ns
Row address setup time	$t_{ASR}$	0	–	0	–	0	–	ns
Row address hold time	$t_{RAH}$	10	–	10	–	10	–	ns
Column address setup time	$t_{ASC}$	0	–	0	–	0	–	ns
Column address hold time	$t_{CAH}$	15	–	15	–	15	–	ns
Column address to RAS lead time	$t_{RAL}$	30	–	35	–	40	–	ns
Read command setup time	$t_{RCS}$	0	–	0	–	0	–	ns
Read command hold time <sup>8)</sup>	$t_{RCH}$	0	–	0	–	0	–	ns
Read command hold time ref. to RAS <sup>8)</sup>	$t_{RRH}$	0	–	0	–	0	–	ns
Write command hold time	$t_{WCH}$	10	–	15	–	15	–	ns
Write command hold time ref. to RAS	$t_{WCR}$	50	–	55	–	60	–	ns
Write command pulse width	$t_{WP}$	10	–	15	–	15	–	ns
Write command to RAS lead time	$t_{RWL}$	20	–	20	–	20	–	ns
Write command to CAS lead time	$t_{CWL}$	20	–	20	–	20	–	ns
Data setup time <sup>9)</sup>	$t_{DS}$	0	–	0	–	0	–	ns
Data hold time <sup>9)</sup>	$t_{DH}$	15	–	15	–	15	–	ns

Notes see page 107.



**AC Characteristics** (cont'd)<sup>4)</sup> $T_A = 0$  to  $70$  °C;  $V_{CC} = 5$  V  $\pm$  10 %;  $t_f = 5$  ns

Parameter	Symbol	Limit Values						Unit
		-60		-70		-80		
		min.	max.	min.	max.	min.	max.	
Refresh period	$t_{REF}$	–	16	–	16	–	16	ms
Refresh period Low Power Version	$t_{REF}$	–	128	–	128	–	128	ms
Write command setup time <sup>10)</sup>	$t_{WCS}$	0	–	0	–	0	–	ns
CAS to WRITE delay time <sup>10)</sup>	$t_{CWD}$	50	–	50	–	50	–	ns
RAS to WRITE delay time <sup>10)</sup>	$t_{RWD}$	90	–	100	–	110	–	ns
Column address to WRITE delay time <sup>10)</sup>	$t_{AWD}$	60	–	65	–	70	–	ns
CAS setup time (CBR cycle)	$t_{CSR}$	5	–	5	–	5	–	ns
CAS hold time (CBR cycle)	$t_{CHR}$	15	–	15	–	15	–	ns
RAS to CAS precharge time	$t_{RPC}$	0	–	0	–	0	–	ns
CAS precharge time (CAS before RAS counter test cycle)	$t_{CPT}$	30	–	40	–	40	–	ns
Write command setup time (test mode entry)	$t_{WTS}$	10	–	10	–	10	–	ns
Write command hold time (in test mode entry cycle)	$t_{WTH}$	10	–	10	–	10	–	ns
Write to RAS precharge time (CBS cycle)	$t_{WRP}$	10	–	10	–	10	–	ns
Write to RAS hold time (CBR cycle)	$t_{WRH}$	10	–	10	–	10	–	ns
OE command hold time	$t_{OEH}$	20	–	20	–	20	–	ns
OE acces time	$t_{OEA}$	–	20	–	20	–	20	ns

Notes see page 107.

### AC Characteristics (cont'd)<sup>4)</sup>

$T_A = 0$  to  $70$  °C;  $V_{CC} = 5\text{ V} \pm 10\%$ ;  $t_T = 5\text{ ns}$

Parameter	Symbol	Limit Values						Unit
		-60		-70		-80		
		min.	max.	min.	max.	min.	max.	
RAS hold time referenced to OE	$t_{ROH}$	10	–	10	–	10	–	ns
Output buffer turn-off delay from OE	$t_{OEZ}$	0	20	0	20	0	20	ns
Data to CAS low delay <sup>14)</sup>	$t_{DZC}$	0	–	0	–	0	–	ns
Data to OE low delay <sup>14)</sup>	$t_{DZO}$	0	–	0	–	0	–	ns
CAS high to data delay <sup>15)</sup>	$t_{CDD}$	20	–	20	–	20	–	ns
OE high to data delay <sup>15)</sup>	$t_{ODD}$	20	–	20	–	20	–	ns
CAS hold time after OE low	$t_{OECH}$	20	–	20	–	20	–	ns

Notes see page 107.

### Capacitance

$T_A = 0$  to  $70$  °C;  $V_{CC} = 5\text{ V} \pm 10\%$ ;  $f = 1\text{ MHz}$

Parameter	Symbol	Limit Values		Unit
		min.	max.	
Input capacitance (A0 to A9)	$C_{I1}$	–	5	pF
Input capacitance (RAS, CAS, WRITE)	$C_{I2}$	–	7	pF
Output capacitance (IO1 to IO4)	$C_{I0}$	–	7	pF

**Notes for pages 101 to 106:**

- 1) All voltages are referenced to  $V_{SS}$
- 2)  $I_{CC1}$ ,  $I_{CC3}$ ,  $I_{CC4}$  and  $I_{CC6}$  depend on cycle rate.
- 3)  $I_{CC1}$ ,  $I_{CC4}$  depend on output loading.
- 4) An initial pause of 200  $\mu$ s is required after power-up followed by 8 RAS cycles of which at least one cycle has to be a refresh cycle, before proper device operation is achieved. In case of using the internal refresh counter, a minimum of 8 CAS-before-RAS initialization cycles instead of 8 RAS cycles are required
- 5)  $V_{ih}$  (min.) and  $V_{il}$  (max.) are reference levels for measuring timing of input signals. Transition times are also measured between  $V_{ih}$  and  $V_{il}$ .
- 6) Measured with a load equivalent to 2 TTL loads and 100 pF.
- 7)  $T_{off}$  (max.),  $t_{OEZ}$  (max.) defines the time at which the output achieves the open-circuit conditions and are not referenced to output voltage levels.
- 8) Either  $t_{RCH}$  or  $t_{RRH}$  must be satisfied for a read cycle.
- 9) These parameters are references to the CAS leading edge in early write and to the WRITE leading edge in read-write cycles.
- 10)  $t_{WCS}$ ,  $t_{RWD}$ ,  $t_{CWD}$  and  $t_{AWD}$  are not restrictive operating parameters. They are included in the data sheet as electrical characteristics only.  
If  $t_{WCS} > t_{WCS}(\text{min.})$ , the cycle is an early write cycle and data out pin will remain open-circuit (high impedance) through the entire cycle; if  $t_{RWD} > t_{RWD}(\text{min.})$ ,  $t_{CWD} > t_{CWD}(\text{min.})$  and  $t_{AWD} > t_{AWD}(\text{min.})$ , the cycle is a read-write cycle and I/O will contain data read from the selected cell. If neither of the above sets of conditions is satisfied, the condition of I/O (at access time) is indeterminate.
- 11) Operation within the  $t_{RCD}(\text{max.})$  limit ensure that  $t_{RAC}(\text{max.})$  can be met.  $t_{RCD}(\text{max.})$  is specified as a reference point only. If  $t_{RAD}$  is greater than the specified  $t_{RCD}(\text{max.})$  limit, then access time is controlled by  $t_{CAC}$ .
- 12) Operation within the  $t_{RAD}(\text{max.})$  limit ensured that  $t_{RAC}(\text{max.})$  can be met.  $t_{RAD}(\text{max.})$  is specified as a reference point only. If  $t_{RAD}$  is greater than the specified  $t_{RAD}(\text{max.})$  limit, then access time is controlled by  $t_{AA}$ .
- 13) AC measurements assume  $t_T = 5$  ns
- 14) Either  $t_{DZC}$  or  $t_{DZO}$  must be satisfied.
- 15) Either  $t_{CDD}$  or  $t_{ODD}$  must be satisfied.

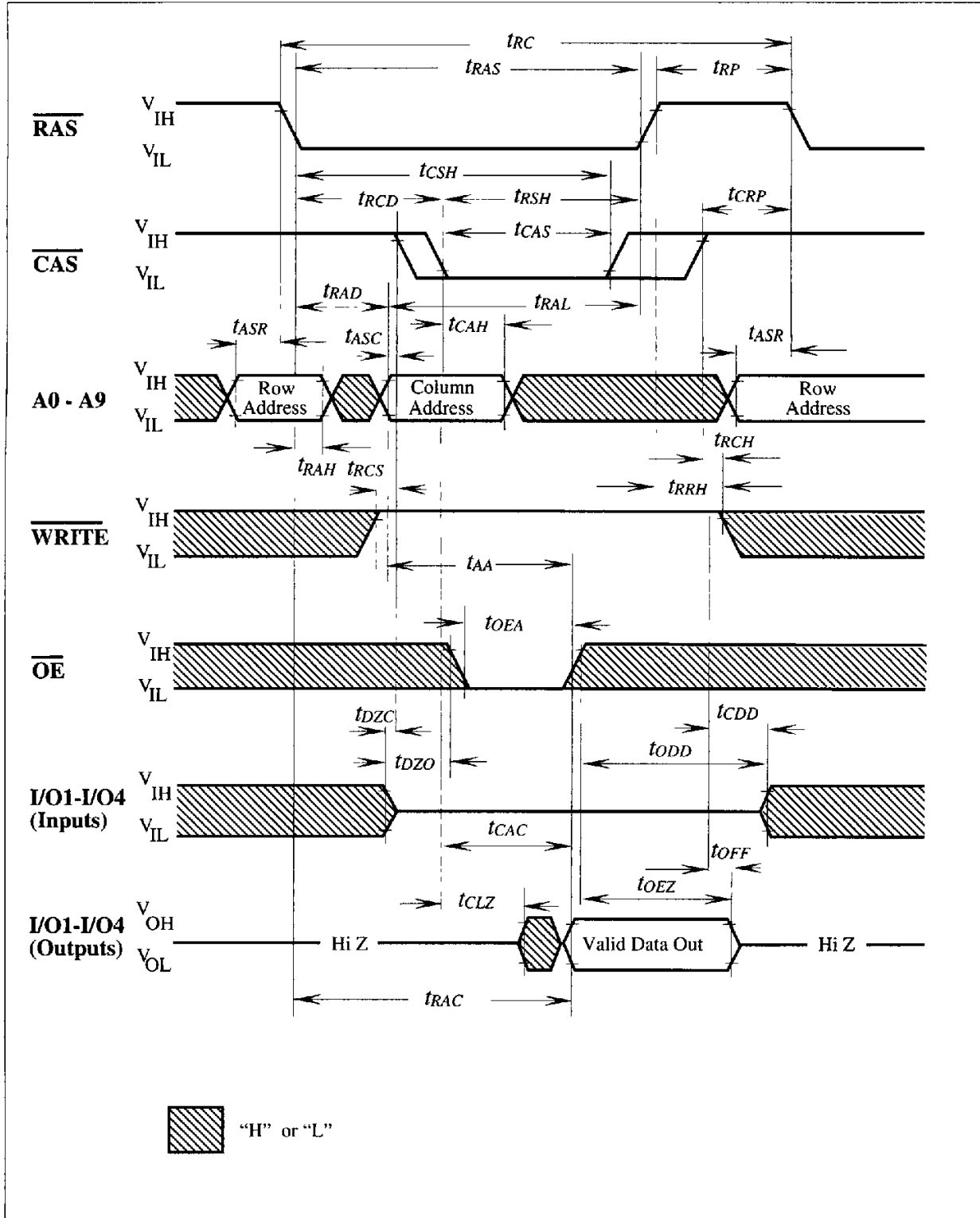

Read Cycle

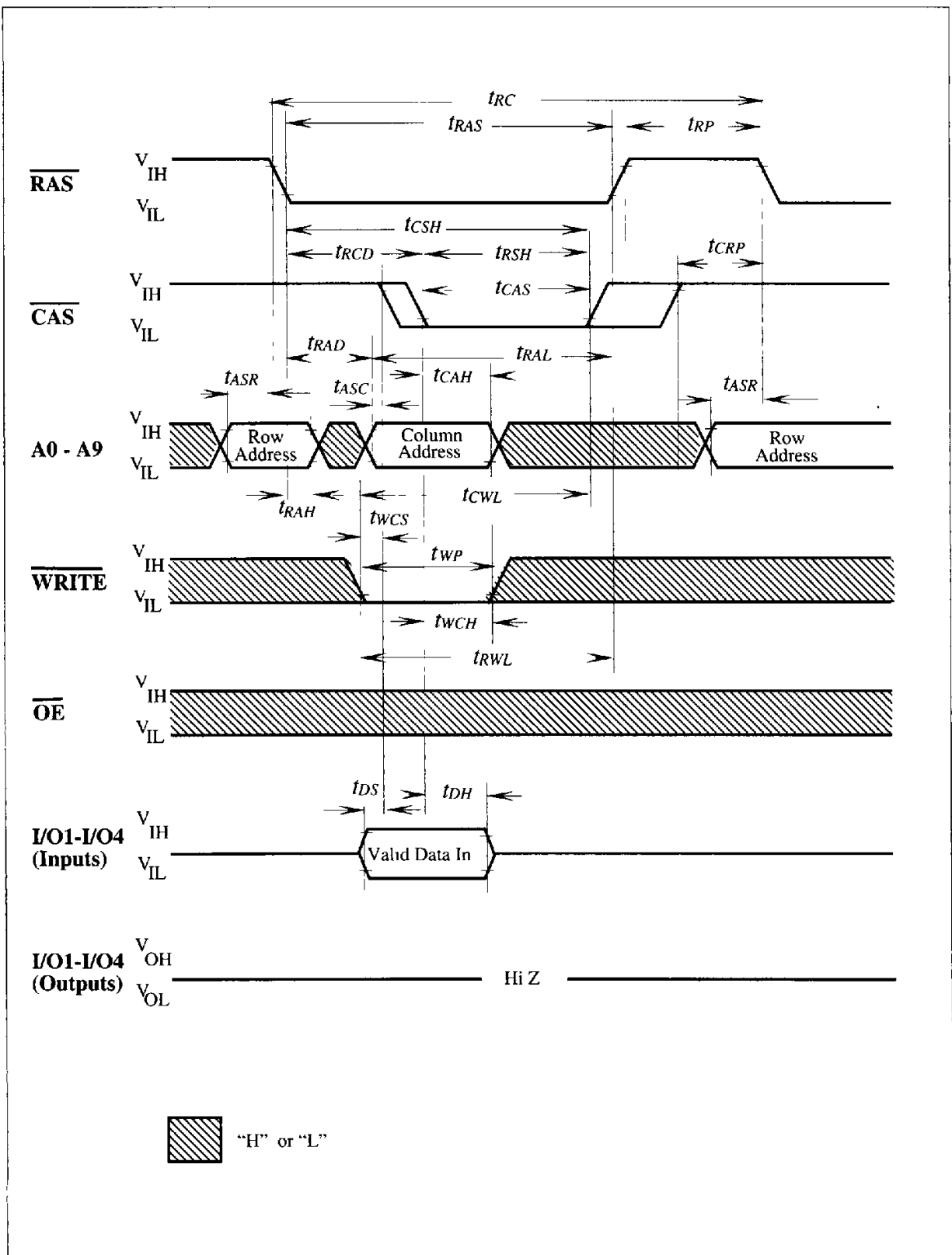

Write Cycle (Early Write)

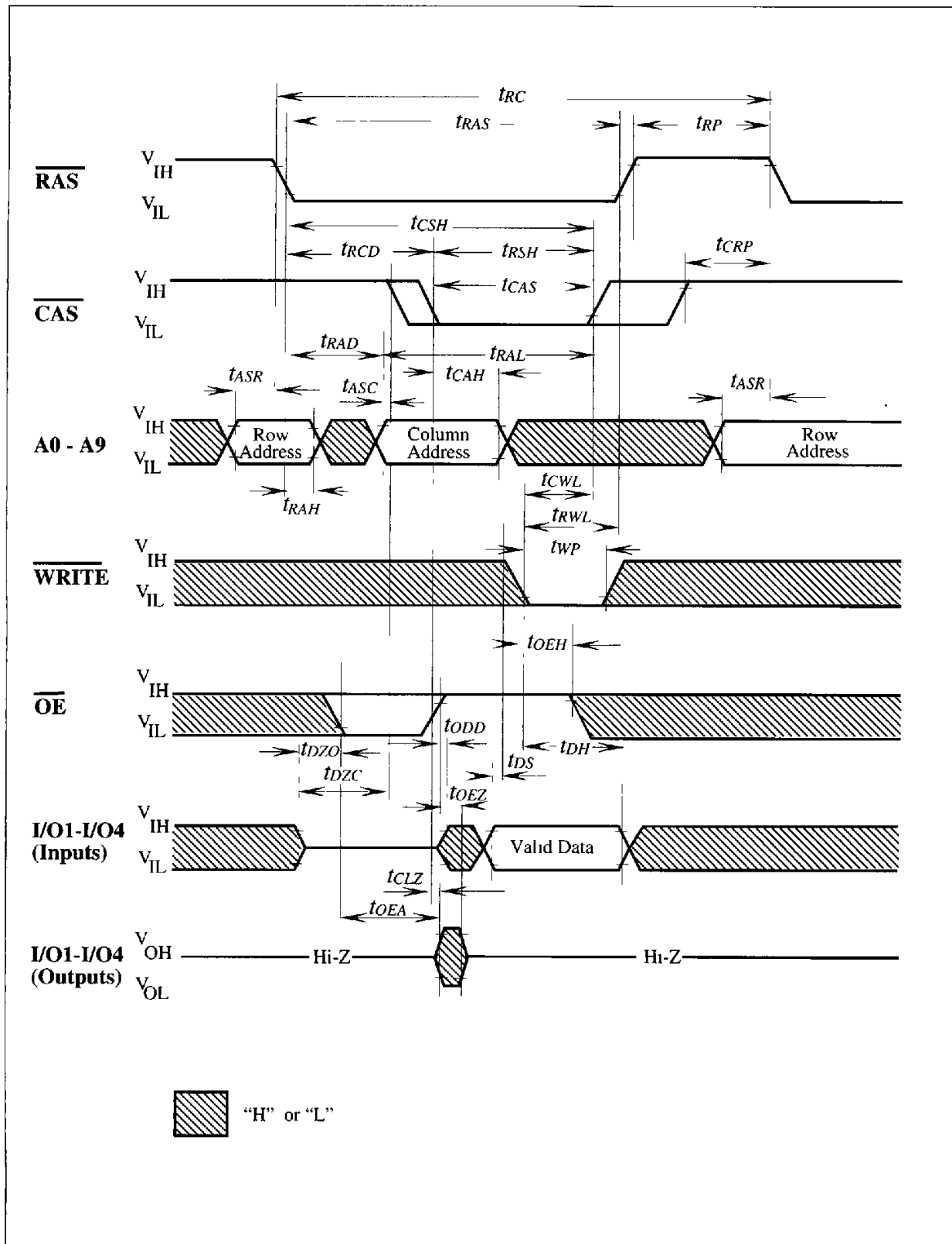

Write Cycle (OE Controlled Write)

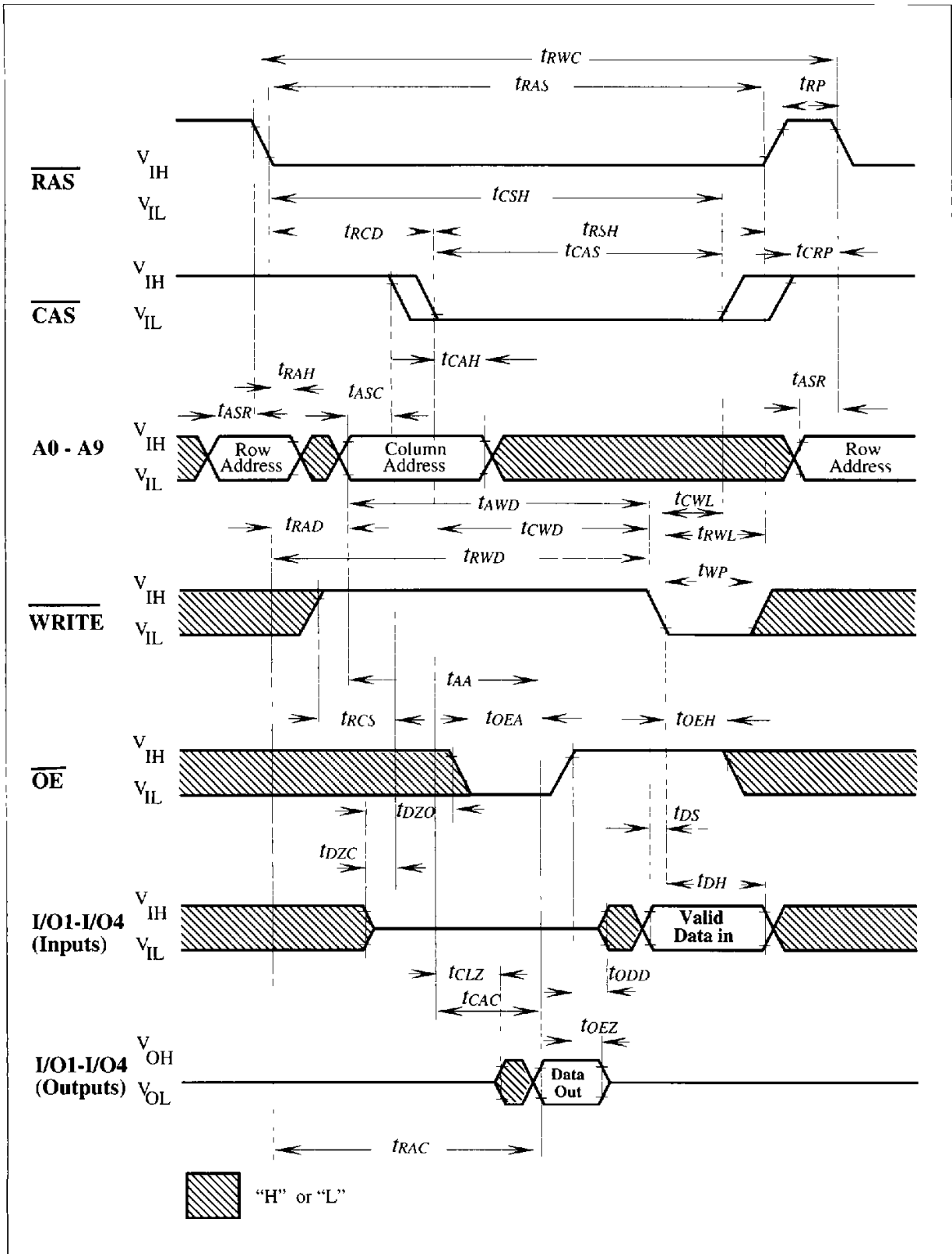

Read-Write (Read-Modify-Write) Cycle

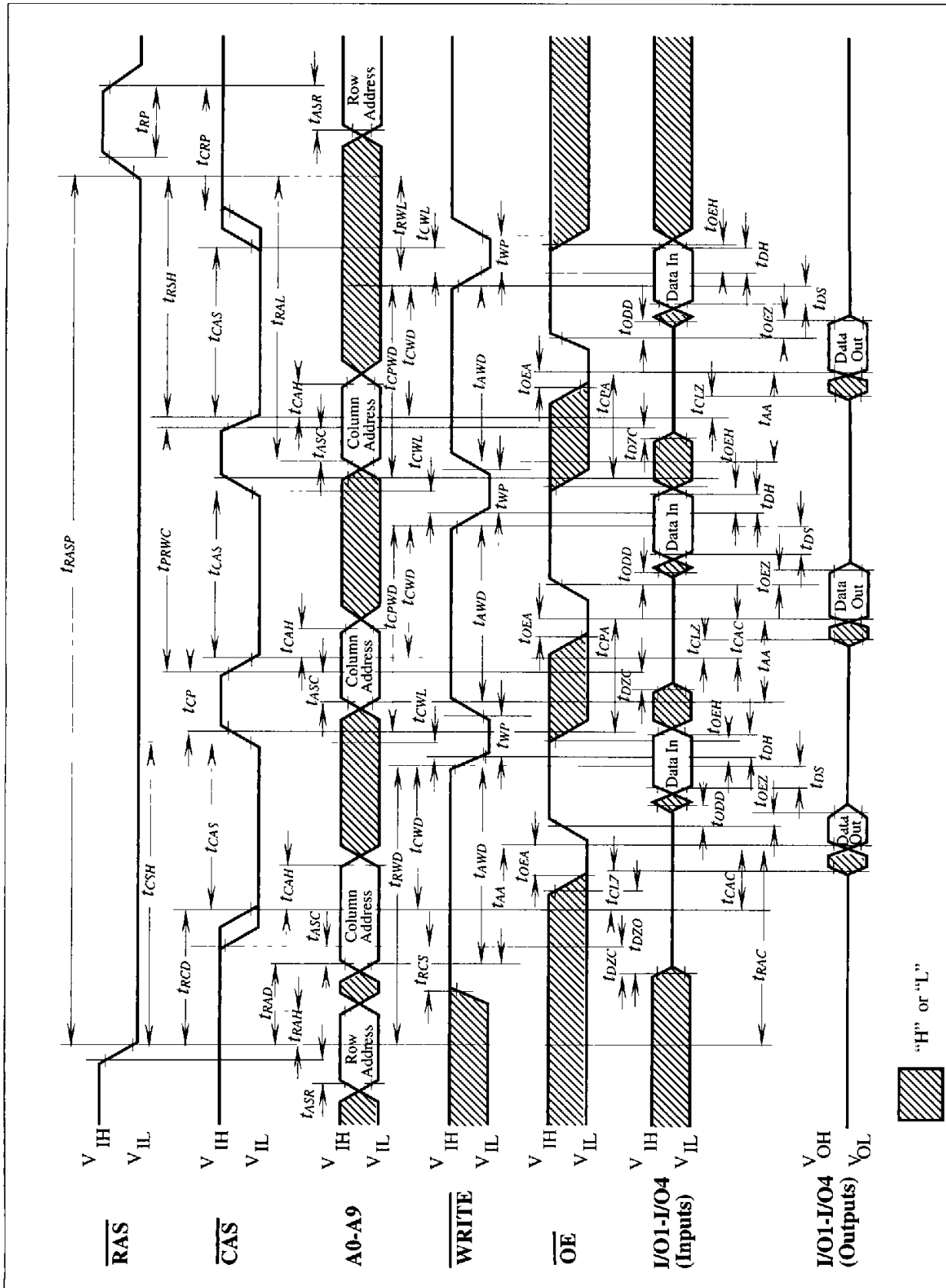

Fast Page Mode Read-Modify-Write Cycle



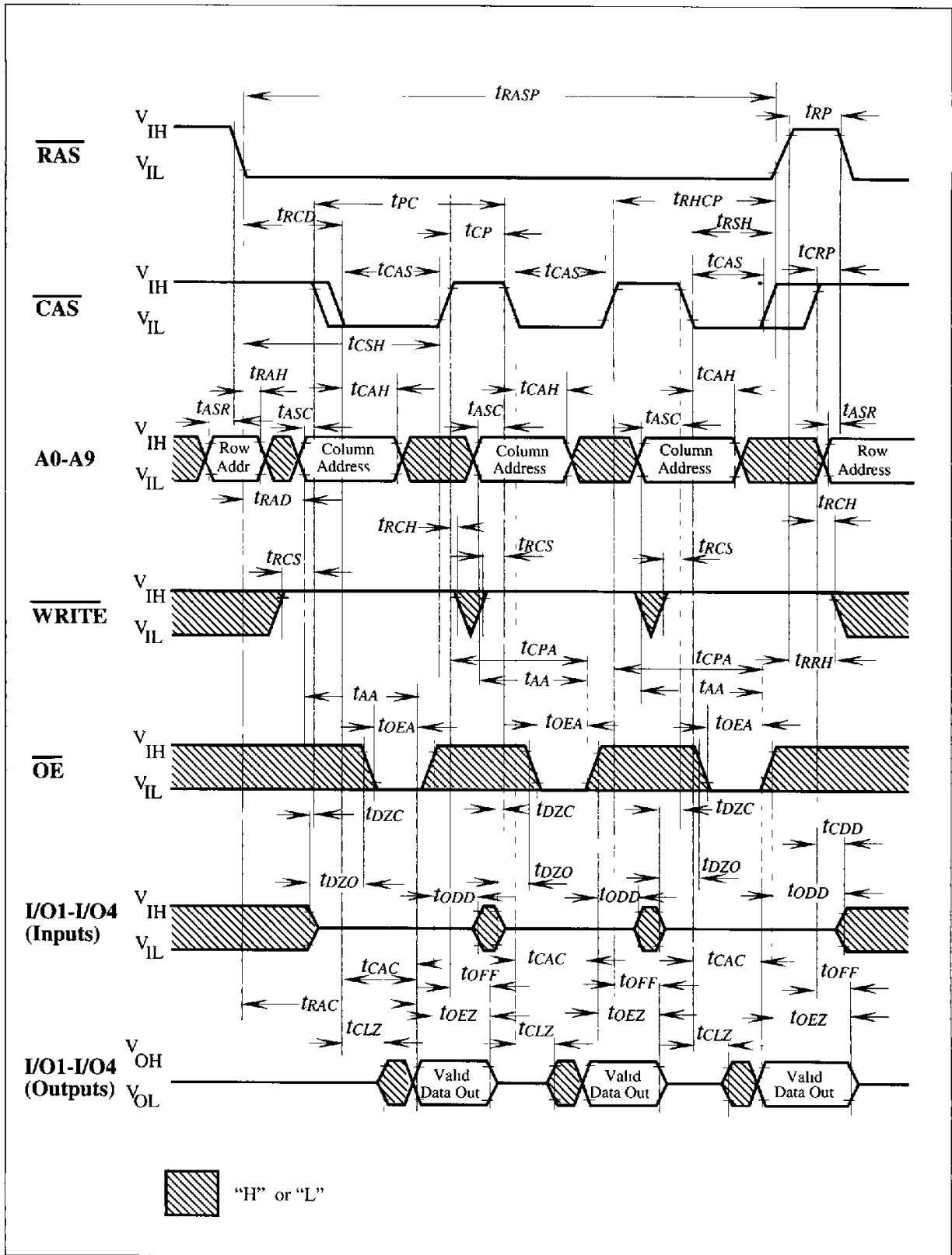

Fast Page Mode Read Cycle

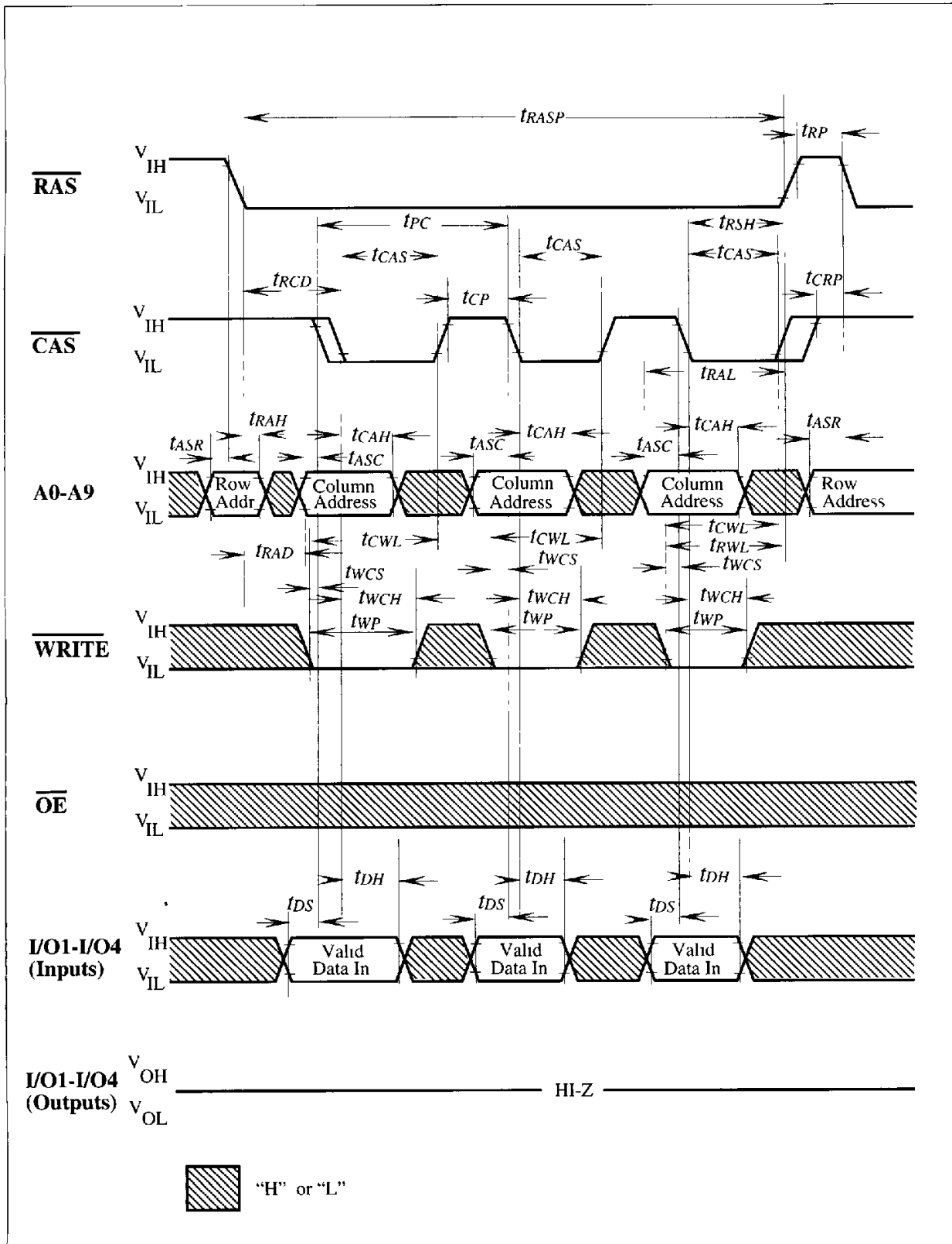

### Fast Page Mode Early Write Cycle

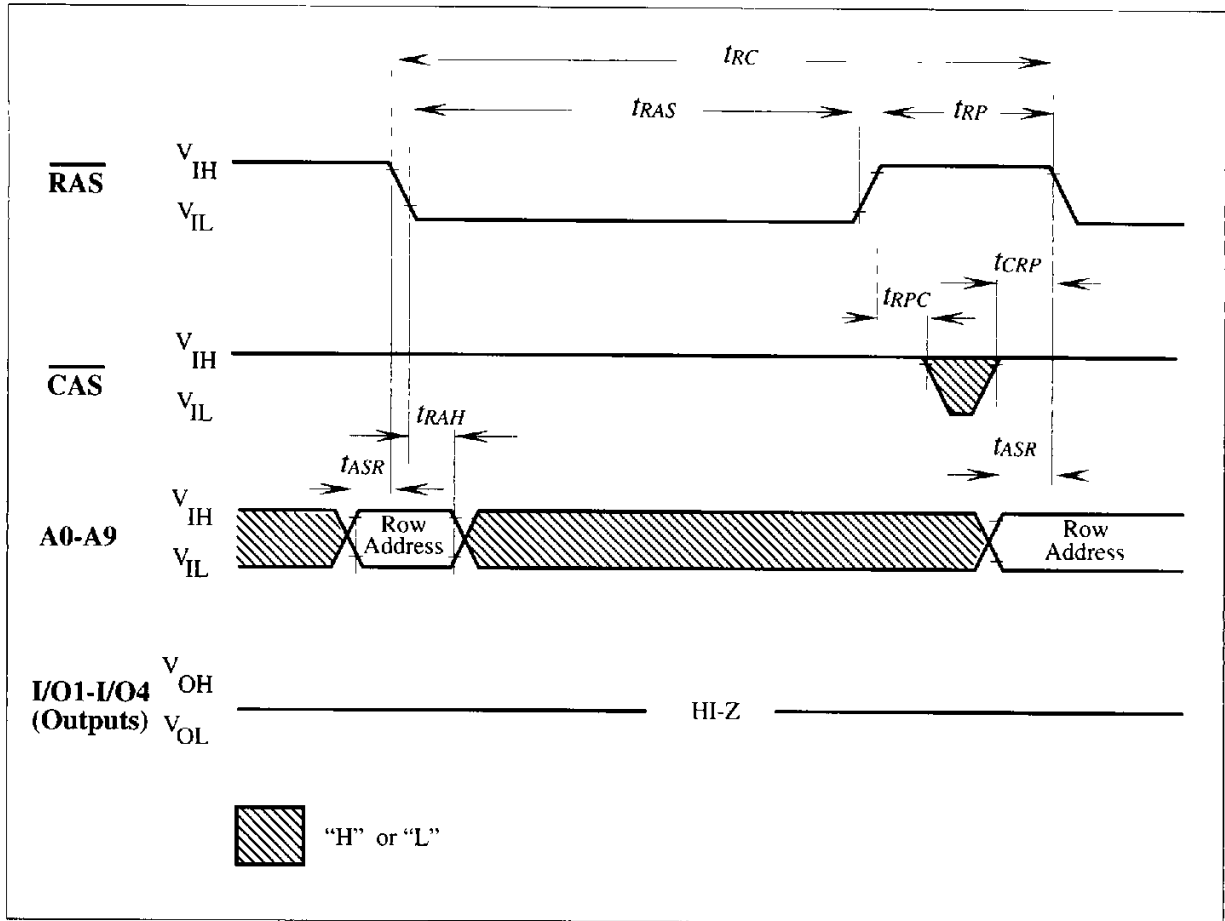

**RAS-Only Refresh Cycle**

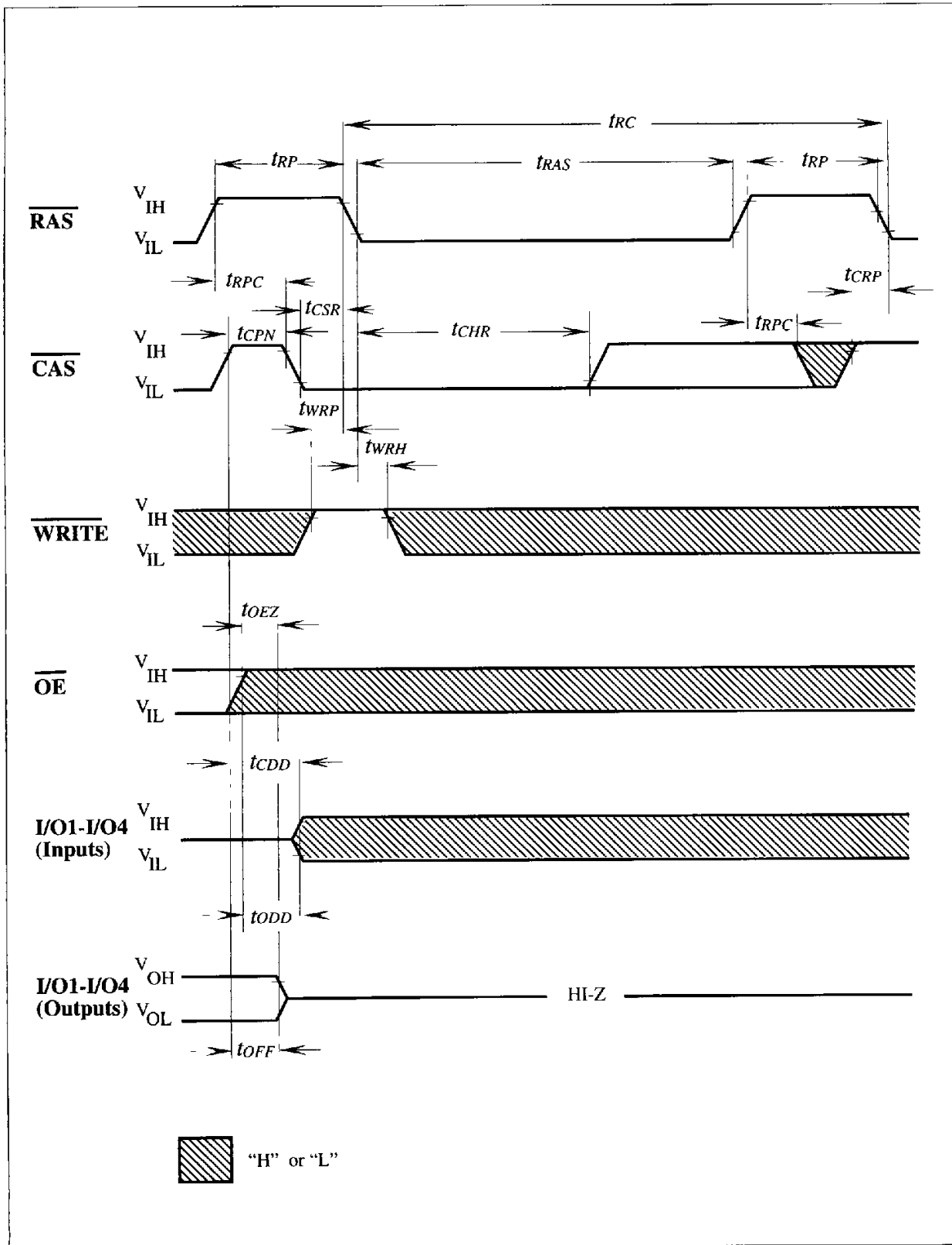

CAS-Before-RAS Refresh Cycle

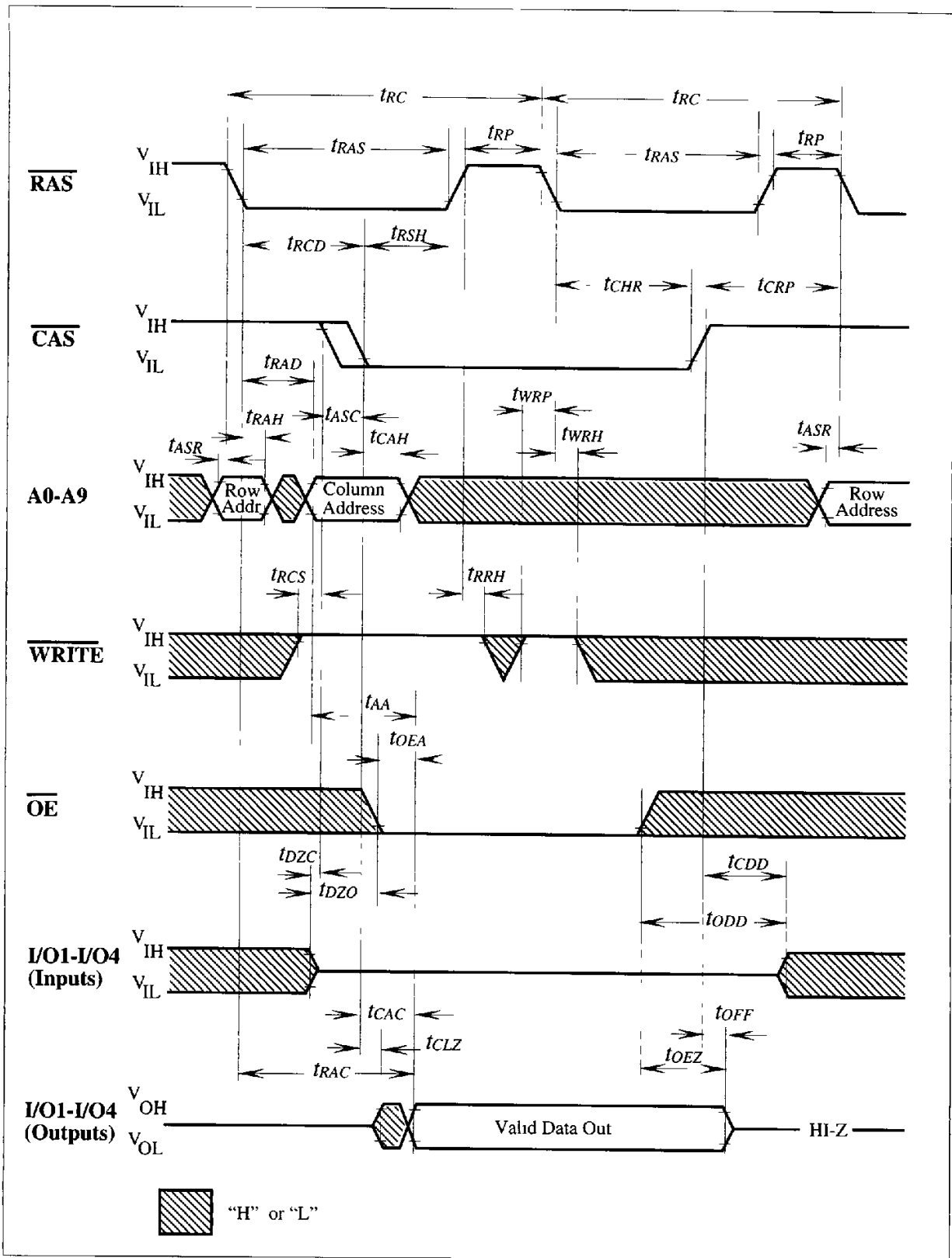

Hidden Refresh Cycle (Read)

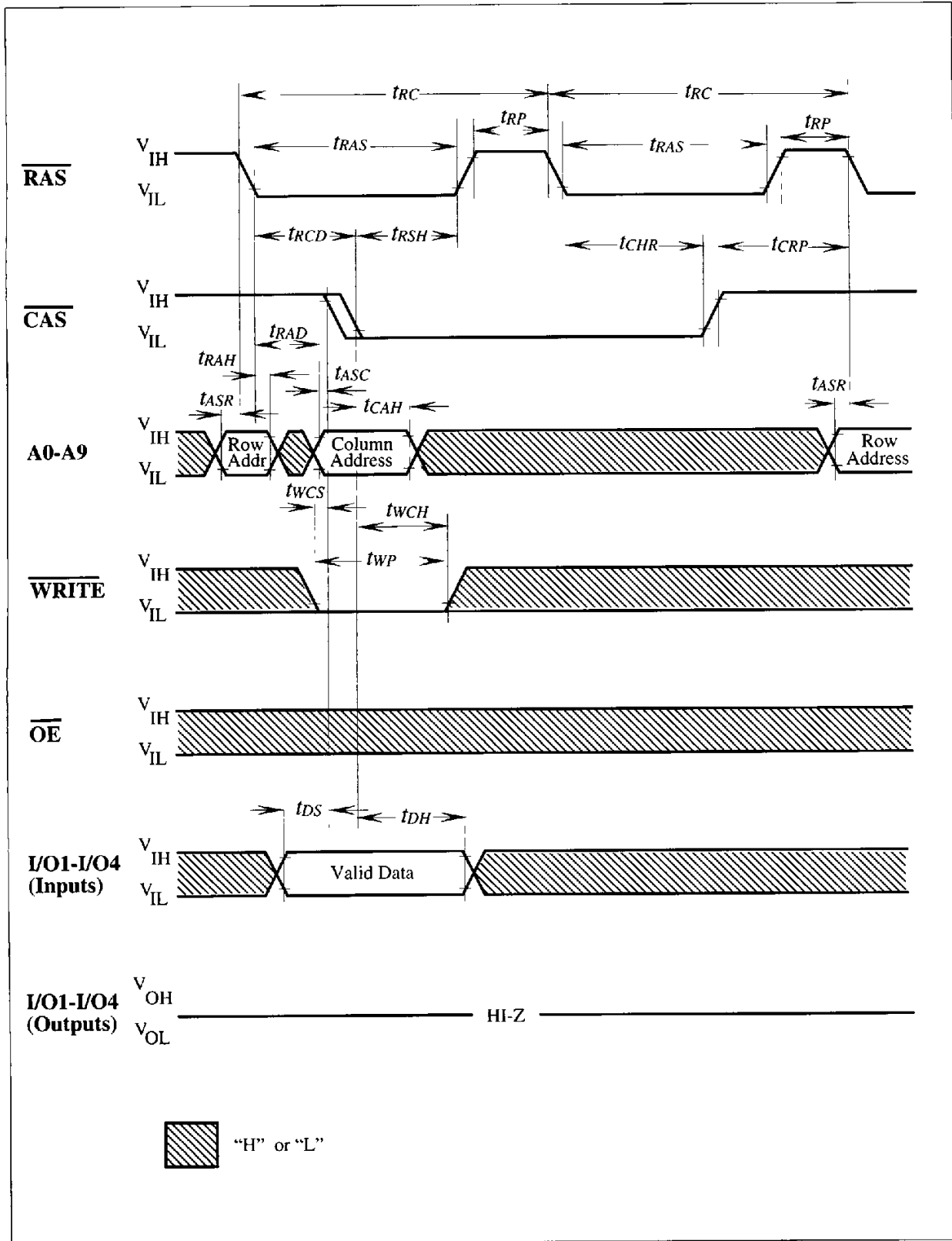

**Hidden Refresh Cycle (Early Write)**

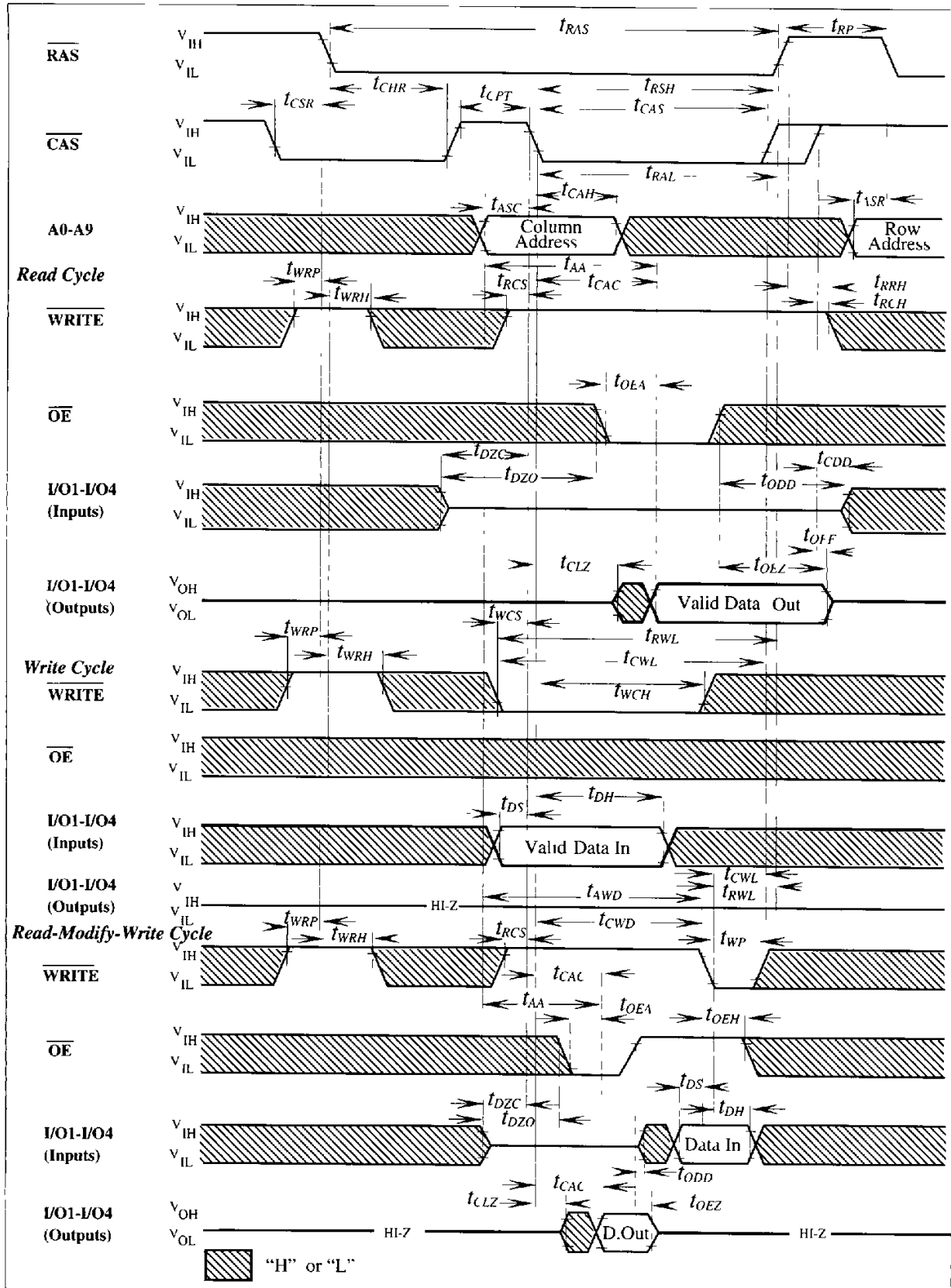

CAS-Before-RAS Refresh Counter Test Cycle

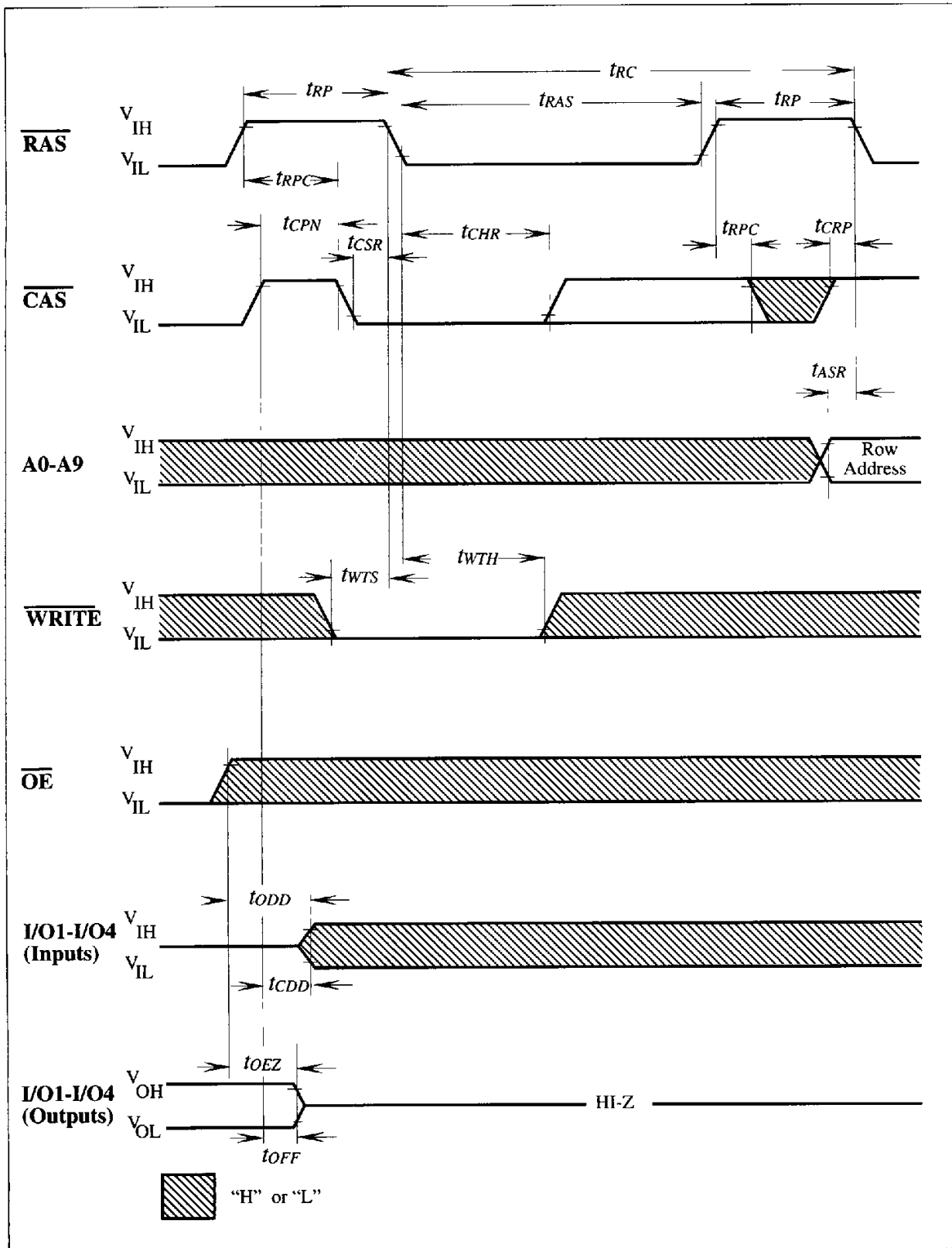

Test Mode Entry



**Test Mode**

As the HYB 514400BJ/BJL/BT/BTL is organized internally as 512K x 8-bits, a test mode cycle using 8:1 compression can be used to improve test time. Note that in the 1M x 4 version the test time is reduced by 1/4 for a linear test pattern.

In a test mode "write" the data from each I/O1 pin is written into eight bits simultaneously (all "1" s or all "0" s). The I/O2-I/O4 inputs are not used for writing in test mode. In test mode "read" each I/O output is used for indicating the test mode result. If the internal eight bits are equal, the I/O would indicate a "1". If they were not equal, the I/O would indicate a "0". Note that in test mode „read“ I/O1-I/O3 are always driven to „ones“ ,i.e. all outputs will be „1“s for a test mode „pass“. The WCBR cycle (WRITE, CAS before RAS) puts the device into test mode. To exit from test mode, a "CAS before RAS refresh", "RAS only refresh" or "Hidden refresh" can be used.

Addresses A10R, A10C and A0C are don't care during test mode.