

### 64 MBit Synchronous DRAM

- High Performance:

	-8	-8B	-10	Units
fCKmax.	125	100	100	MHz
tCK3	8	10	10	ns
tAC3	6	6	7	ns
tCK2	10	12	15	ns
tAC2	6	7	8	ns

- Fully Synchronous to Positive Clock Edge
- 0 to 70 °C operating temperature
- Four Banks controlled by BA0 & BA1
- Programmable  $\overline{\text{CAS}}$  Latency: 2 & 3
- Programmable Wrap Sequence: Sequential or Interleave
- Programmable Burst Length: 1, 2, 4, 8
- full page (optional) for sequential wrap around
- Multiple Burst Read with Single Write Operation
- Automatic and Controlled Precharge Command
- Data Mask for Read / Write control (x4, x8)
- Data Mask for byte control (x16)
- Auto Refresh (CBR) and Self Refresh
- Suspend Mode and Power Down Mode
- 4096 refresh cycles / 64 ms
- Random Column Address every CLK ( 1-N Rule)
- Single 3.3V +/- 0.3V Power Supply
- LVTTL Interface version
- Plastic Packages:  
P-TSOPII-54 400mil width (x4, x8, x16)
- -8 version for PC100 2-2-2 applications  
-8B version for PC100 3-2-3 applications

The HYB39S64400/800/160AT are four bank Synchronous DRAM's organized as 4 banks x 4MBit x4, 4 banks x 2MBit x8 and 4 banks x 1Mbit x16 respectively. These synchronous devices achieve high speed data transfer rates by employing a chip architecture that prefetches multiple bits and then synchronizes the output data to a system clock. The chip is fabricated with SIEMENS' advanced quarter micron 64MBit DRAM process technology.

The device is designed to comply with all JEDEC standards set for synchronous DRAM products, both electrically and mechanically. All of the control, address, data input and output circuits are synchronized with the positive edge of an externally supplied clock.

Operating the four memory banks in an interleave fashion allows random access operation to occur at higher rate than is possible with standard DRAMs. A sequential and gapless data rate is possible depending on burst length,  $\overline{\text{CAS}}$  latency and speed grade of the device.

Auto Refresh (CBR) and Self Refresh operation are supported. These devices operates with a single 3.3V +/- 0.3V power supply and are available in TSOPII packages.

The -8 version of this product is best suited for use on a 100 Mhz bus for both CAS latencies 2 & 3.

### Ordering Information

Type	Ordering Code	Package	Description
<i>LVTTTL-version:</i>			
HYB 39S64400AT-8		P-TSOP-54-2 (400mil)	4B x 4M x 4 SDRAM PC100-222
HYB 39S64400AT-8B		P-TSOP-54-2 (400mil)	4B x 4M x 4 SDRAM PC100-323
HYB 39S64400AT-10		P-TSOP-54-2 (400mil)	4B x 4M x 4 SDRAM PC66-222
HYB 39S64800AT-8		P-TSOP-54-2 (400mil)	4B x 2M x 8 SDRAM PC100-222
HYB 39S64800AT-8B		P-TSOP-54-2 (400mil)	4B x 2M x 8 SDRAM PC100-323
HYB 39S64800AT-10		P-TSOP-54-2 (400mil)	4B x 2M x 8 SDRAM PC66-222
HYB 39S64160AT-8		P-TSOP-54-2 (400mil)	4B x 1M x 16 SDRAM PC100-222
HYB 39S64160AT-8B		P-TSOP-54-2 (400mil)	4B x 1M x 16 SDRAM PC100-323
HYB 39S64160AT-10		P-TSOP-54-2 (400mil)	4B x 1M x 16 SDRAM PC66-222
HYB 39S64xxx0ATL-8/-10		P-TSOP-54-2 (400mil)	Low Power (L-versions)

### Pin Description and Pinouts:

<b>CLK</b>	Clock Input	<b>DQ</b>	Data Input /Output
<b>CKE</b>	Clock Enable	<b>DQM, LDQM, UDQM</b>	Data Mask
<b><math>\overline{CS}</math></b>	Chip Select	<b>Vdd</b>	Power (+3.3V)
<b><math>\overline{RAS}</math></b>	Row Address Strobe	<b>Vss</b>	Ground
<b><math>\overline{CAS}</math></b>	Column Address Strobe	<b>Vddq</b>	Power for DQ's (+ 3.3V)
<b><math>\overline{WE}</math></b>	Write Enable	<b>Vssq</b>	Ground for DQ's
<b>A0-A11</b>	Address Inputs	<b>NC</b>	not connected
<b>BA0, BA1</b>	Bank Select		

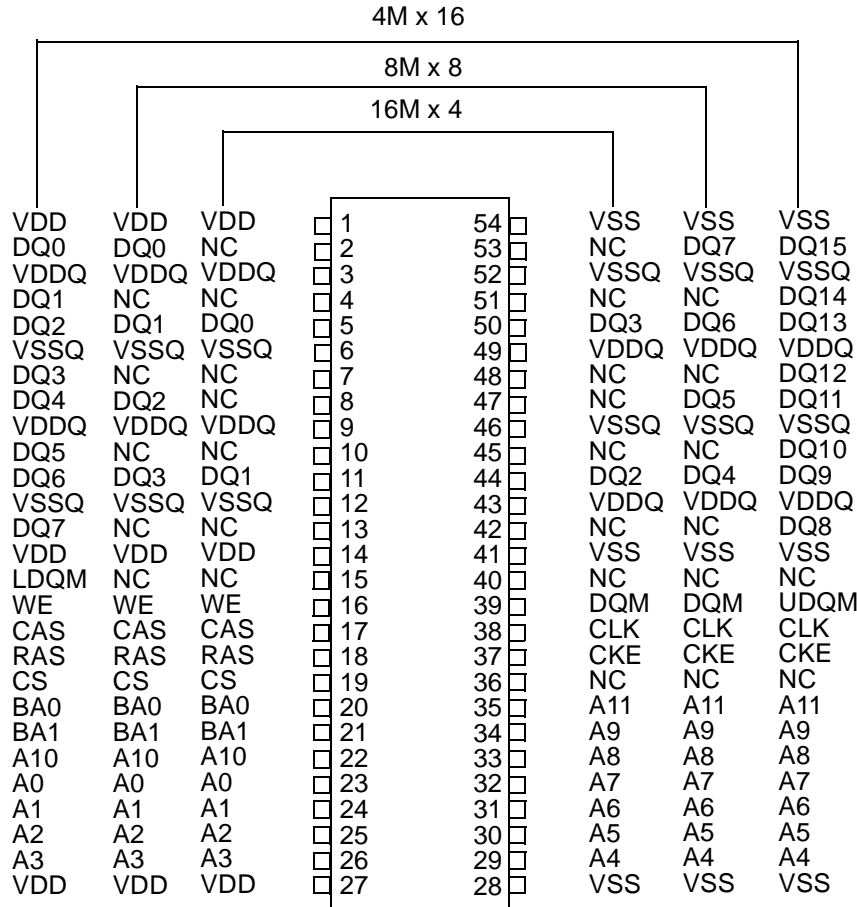

**TSOPII-54 (10.16 mm x 22.22 mm, 0.8 mm pitch)**

**Pinout for x4, x8 & x16 organised 64M-SDRAMs**

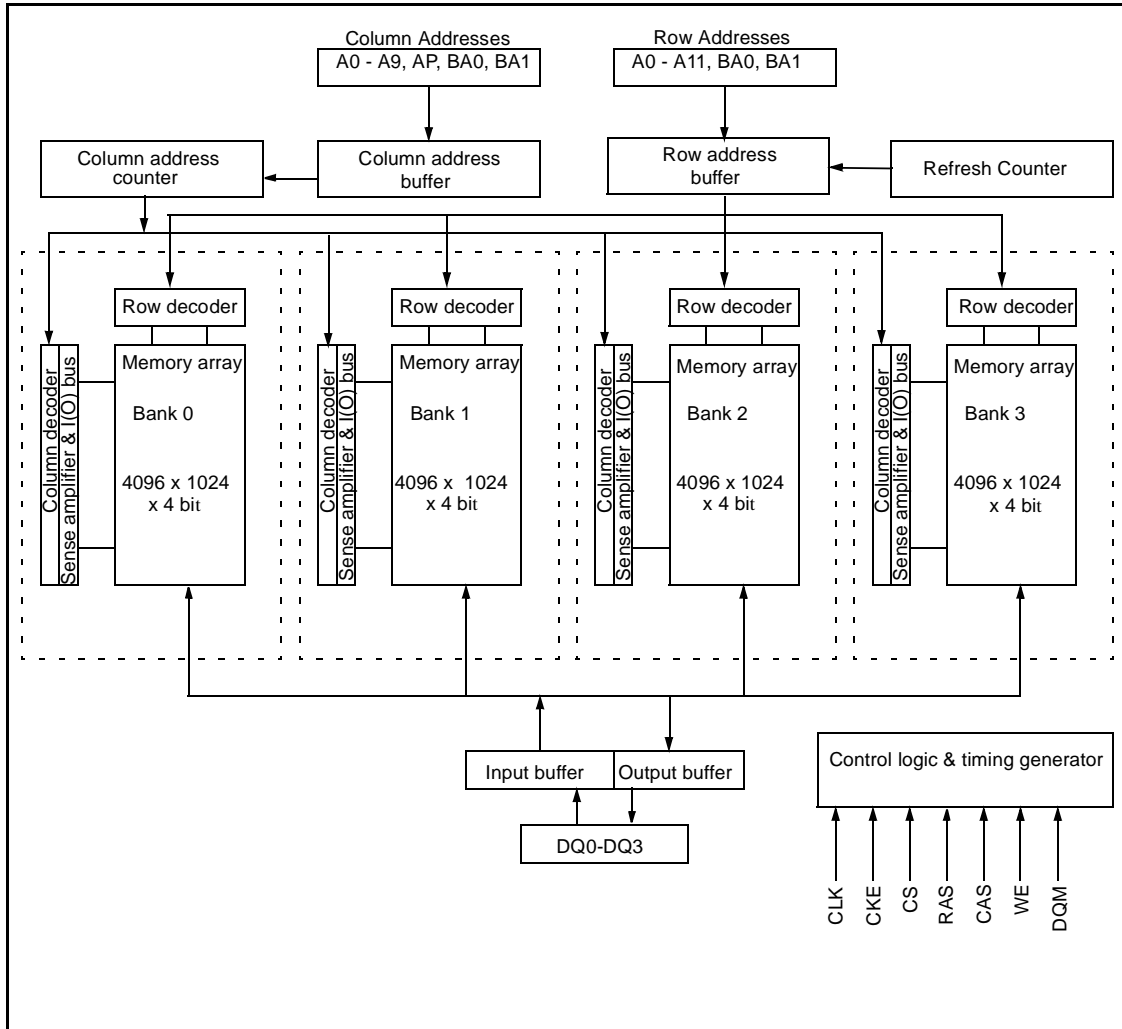

**Block Diagram for 4 bank x 4M x 4 SDRAM**

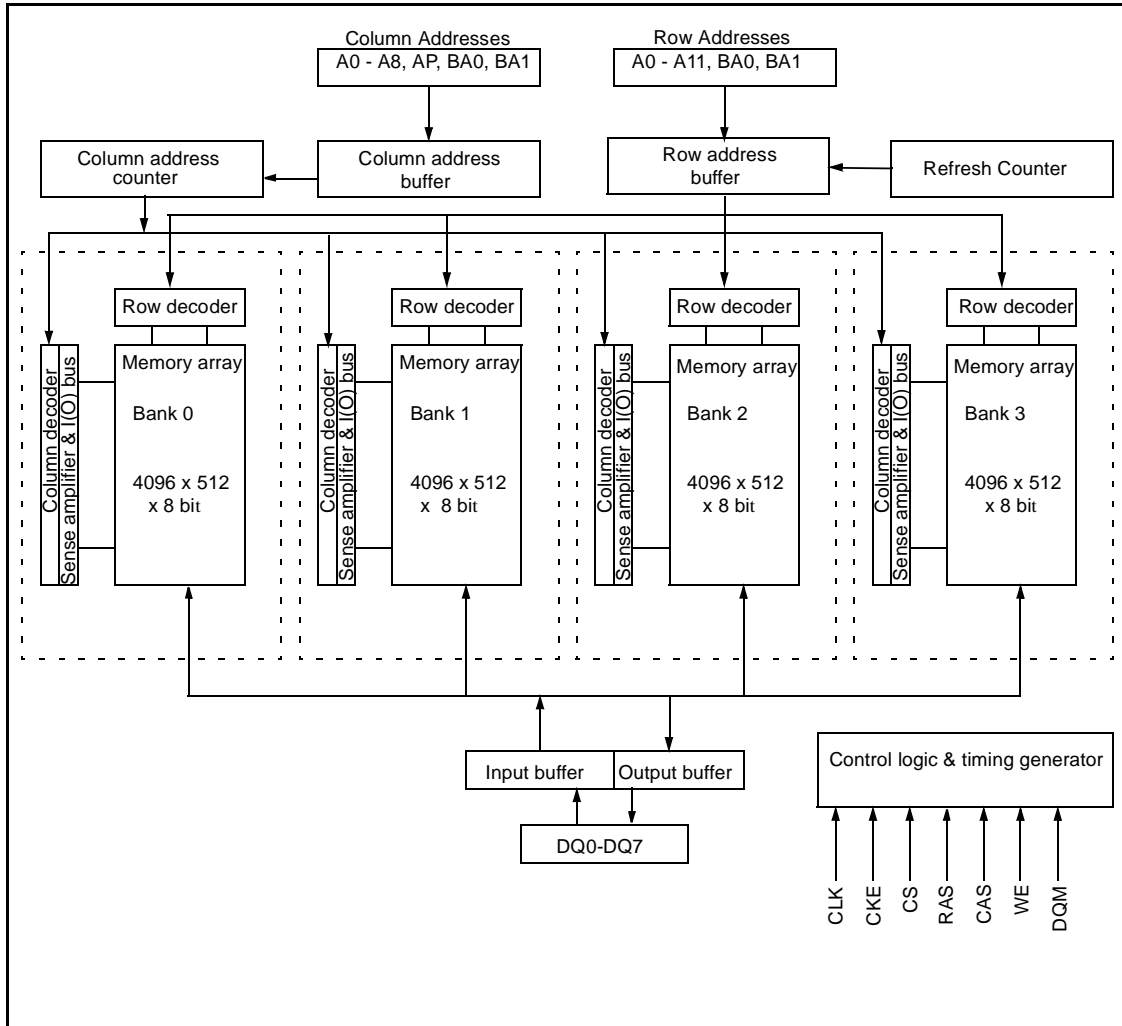

Block Diagram for 4 banks x 2M x 8 SDRAM

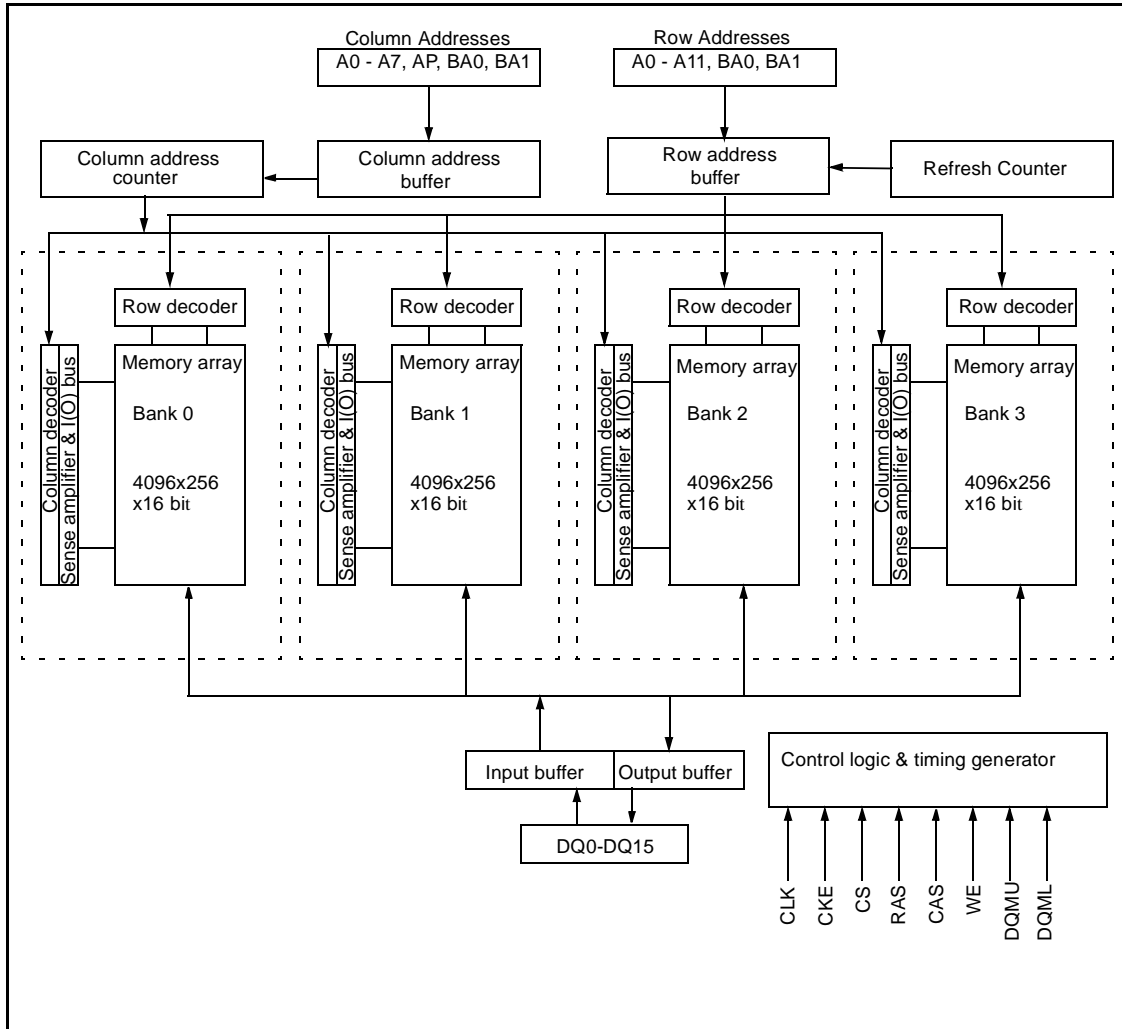

Block Diagram for 4 banks x 1M x16 SDRAM

### Signal Pin Description

Pin	Type	Signal	Polarity	Function
CLK	Input	Pulse	Positive Edge	The system clock input. All of the SDRAM inputs are sampled on the rising edge of the clock.
CKE	Input	Level	Active High	Activates the CLK signal when high and deactivates the CLK signal when low, thereby initiates either the Power Down mode, Suspend mode, or the Self Refresh mode.
$\overline{CS}$	Input	Pulse	Active Low	$\overline{CS}$ enables the command decoder when low and disables the command decoder when high. When the command decoder is disabled, new commands are ignored but previous operations continue.
$\overline{RAS}$ , $\overline{CAS}$ , $\overline{WE}$	Input	Pulse	Active Low	When sampled at the positive rising edge of the clock, $\overline{CAS}$ , $\overline{RAS}$ , and $\overline{WE}$ define the command to be executed by the SDRAM.
A0 - A11	Input	Level	—	<p>During a Bank Activate command cycle, A0-A11 defines the row address (RA0-RA11) when sampled at the rising clock edge.</p> <p>During a Read or Write command cycle, A0-An defines the column address (CA0-CAn) when sampled at the rising clock edge. CAn depends from the SDRAM organisation:</p> <p>16M x 4 SDRAM CAn = CA9 (Page Length = 1024 bits)              8M x 8 SDRAM CAn = CA8 (Page Length = 512 bits)              4M x 16 SDRAM CAn = CA7 (Page Length = 256 bits)</p> <p>In addition to the column address, A10(=AP) is used to invoke autoprecharge operation at the end of the burst read or write cycle. If A10 is high, autoprecharge is selected and BA0, BA1 defines the bank to be precharged. If A10 is low, autoprecharge is disabled.</p> <p>During a Precharge command cycle, A10 (=AP) is used in conjunction with BA0 and BA1 to control which bank(s) to precharge. If A10 is high, all four banks will be precharged regardless of the state of BA0 and BA1. If A10 is low, then BA0 and BA1 are used to define which bank to precharge.</p>
BA0,BA1	Input	Level	—	Bank Select (BS) Inputs. Selects which bank is to be active.
DQx	Input Output	Level	—	Data Input/Output pins operate in the same manner as on conventional DRAMs.
DQM LDQM UDQM	Input	Pulse	Active High	<p>The Data Input/Output mask places the DQ buffers in a high impedance state when sampled high. In Read mode, DQM has a latency of two clock cycles and controls the output buffers like an output enable. In Write mode, DQM has a latency of zero and operates as a word mask by allowing input data to be written if it is low but blocks the write operation if DQM is high.</p> <p>One DQM input is present in x4 and x8 SDRAMs, LDQM and UDQM controls the lower and upper bytes in x16 SDRAMs.</p>
VDD,VSS	Supply			Power and ground for the input buffers and the core logic.
VDDQ VSSQ	Supply	—	—	Isolated power supply and ground for the output buffers to provide improved noise immunity.

### Operation Definition

All of SDRAM operations are defined by states of control signals  $\overline{CS}$ ,  $\overline{RAS}$ ,  $\overline{CAS}$ ,  $\overline{WE}$ , and DQM at the positive edge of the clock. The following list shows the truth table for the operation commands.

Operation	Device State	CKE n-1	CKE n	$\overline{CS}$	$\overline{RAS}$	$\overline{CAS}$	$\overline{WE}$	DQM	A0-9, A11	A10	BS0 BS1
Row Activate (ACT)	Idle <sup>3</sup>	H	X	L	L	H	H	X	V	V	V
Read (READ)	Active <sup>3</sup>	H	X	L	H	L	H	X	V	L	V
Read w/ Autoprecharge (READA)	Active <sup>3</sup>	H	X	L	H	L	H	X	V	H	V
Write (WRITE)	Active <sup>3</sup>	H	X	L	H	L	L	X	V	L	V
Write w/ Autoprecharge (WRITEA)	Active <sup>3</sup>	H	X	L	H	L	L	X	V	H	V
Row Precharge (PRE)	Any	H	X	L	L	H	L	X	X	L	V
Precharge All (PREA)	Any	H	X	L	L	H	L	X	X	H	X
Mode Register Set (MRS)	Idle	H	X	L	L	L	L	X	V	V	V
No Operation (NOP)	Any	H	X	L	H	H	H	X	X	X	X
Device Deselect (INHBT)	Any	H	X	H	X	X	X	X	X	X	X
Auto Refresh (REFA)	Idle	H	H	L	L	L	H	X	X	X	X
Self Refresh Entry (REFS-EN)	Idle	H	L	L	L	L	H	X	X	X	X
Self Refresh Exit (REFS-EX)	Idle (Self Refr.)	L	H	H	X	X	X	X	X	X	X
				L	H	H	X				
Power Down Entry (PDN-EN)	Idle Active <sup>5</sup>	H	L	H	X	X	X	X	X	X	X
				L	H	H	X				
Power Down Exit (PDN-EX)	Any (Power Down)	L	H	H	X	X	X	X	X	X	X
				L	H	H	L				
Data Write/Output Enable	Active	H	X	X	X	X	X	L	X	X	X
Data Write/Output Disable	Active	H	X	X	X	X	X	H	X	X	X

### Note:

1. V = Valid, x = Don't Care, L = Low Level, H = High Level
2. CKE<sub>n</sub> signal is input level when commands are provided, CKE<sub>n-1</sub> signal is input level one clock before the commands are provided.
3. This is the state of the banks designated by BS0, BS1 signals.
4. Device state is Full Page Burst operation
5. Power Down Mode can not entry in the burst cycle. When this command assert in the burst mode cycle device is clock suspend mode.



### Address Input for Mode Set (Mode Register Operation)

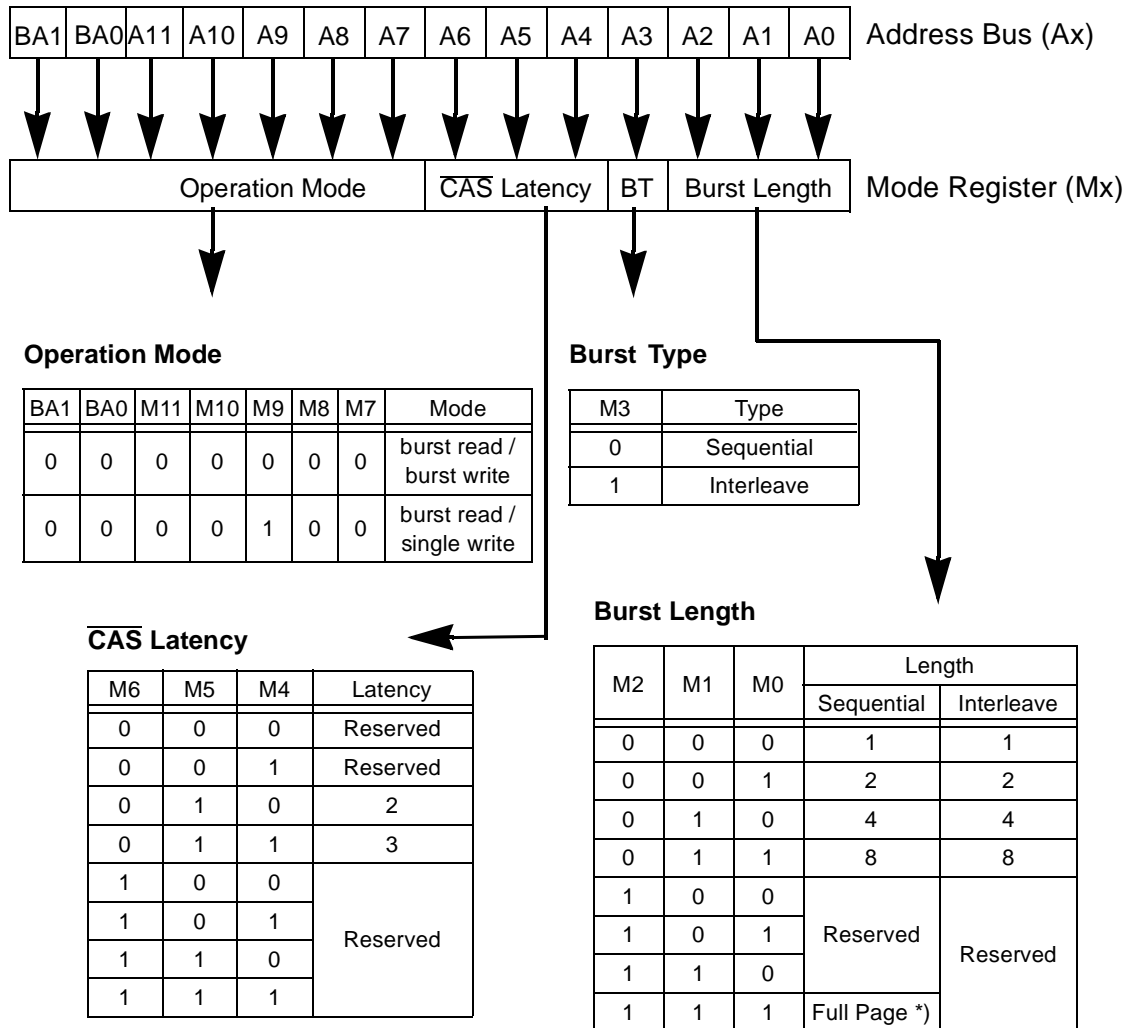

\*) optional

### Power On and Initialization

The default power on state of the mode register is supplier specific and may be undefined. The following power on and initialization sequence guarantees the device is preconditioned to each users specific needs. Like a conventional DRAM, the Synchronous DRAM must be powered up and initialized in a predefined manner. During power on, all VDD and VDDQ pins must be built up simultaneously to the specified voltage when the input signals are held in the "NOP" state. The power on voltage must not exceed VDD+0.3V on any of the input pins or VDD supplies. The CLK signal must be started at the same time. After power on, an initial pause of 200  $\mu$ s is required followed by a precharge of both banks using the precharge command. To prevent data contention on the DQ bus during power on, it is required that the DQM and CKE pins be held high during the initial pause period. Once all banks have been precharged, the Mode Register Set Command must be issued to initialize the Mode Register. A minimum of eight Auto Refresh cycles (CBR) are also required. These may be done before or after programming the Mode Register. Failure to follow these steps may lead to unpredictable start-up modes.

### Programming the Mode Register

The Mode register designates the operation mode at the read or write cycle. This register is divided into 4 fields. A Burst Length Field to set the length of the burst, an Addressing Selection bit to program the column access sequence in a burst cycle (interleaved or sequential), a CAS **Latency** Field to set the access time at clock cycle and a Operation mode field to differentiate between normal operation (Burst read and burst Write) and a special Burst Read and Single Write mode. The mode set operation must be done before any activate command after the initial power up. Any content of the mode register can be altered by re-executing the mode set command. All banks must be in precharged state and CKE must be high at least one clock before the mode set operation. After the mode register is set, a Standby or NOP command is required. Low signals of  $\overline{\text{RAS}}$ ,  $\overline{\text{CAS}}$ , and  $\overline{\text{WE}}$  at the positive edge of the clock activate the mode set operation. Address input data at this timing defines parameters to be set as shown in the previous table.

### Read and Write Operation

When  $\overline{\text{RAS}}$  is low and both  $\overline{\text{CAS}}$  and  $\overline{\text{WE}}$  are high at the positive edge of the clock, a RAS cycle starts. According to address data, a word line of the selected bank is activated and all of sense amplifiers associated to the wordline are set. A CAS cycle is triggered by setting  $\overline{\text{RAS}}$  high and  $\overline{\text{CAS}}$  low at a clock timing after a necessary delay,  $t_{\text{RCD}}$ , from the RAS timing.  $\overline{\text{WE}}$  is used to define either a read ( $\overline{\text{WE}} = \text{H}$ ) or a write ( $\overline{\text{WE}} = \text{L}$ ) at this stage.

SDRAM provides a wide variety of fast access modes. In a single CAS cycle, serial data read or write operations are allowed at up to a 143 MHz data rate. The numbers of serial data bits are the burst length programmed at the mode set operation, i.e., one of 1, 2, 4, 8 and full page, where full page is an optional feature in this device. Column addresses are segmented by the burst length and serial data accesses are done within this boundary. The first column address to be accessed is supplied at the CAS timing and the subsequent addresses are generated automatically by the programmed burst length and its sequence. For example, in a burst length of 8 with interleave sequence, if the first address is '2', then the rest of the burst sequence is 3, 0, 1, 6, 7, 4, and 5.

Full page burst operation is only possible using the sequential burst type and page length is a function of the I/O organisation and column addressing. Full page burst operation do not self terminate once the burst length has been reached. In other words, unlike burst length of 2, 3 or 8, full page burst continues until it is terminated using another command.

Similar to the page mode of conventional DRAM's, burst read or write accesses on any column address are possible once the RAS cycle latches the sense amplifiers. The maximum tRAS or the refresh interval time limits the number of random column accesses. A new burst access can be done even before the previous burst ends. The interrupt operation at every clock cycle is supported. When the previous burst is interrupted, the remaining addresses are overridden by the new address with the full burst length. An interrupt which accompanies an operation change from a read to a write is possible by exploiting DQM to avoid bus contention.

When two or more banks are activated sequentially, interleaved bank read or write operations are possible. With the programmed burst length, alternate access and precharge operations on two or more banks can realize fast serial data access modes among many different pages. Once two or more banks are activated, column to column interleave operation can be done between different pages.

### Burst Length and Sequence:

Burst Length	Starting Address (A2 A1 A0)	Sequential Burst Addressing (decimal)	Interleave Burst Addressing (decimal)
2	xx0	0, 1	0, 1
	xx1	1, 0	1, 0
4	x00	0, 1, 2, 3	0, 1, 2, 3
	x01	1, 2, 3, 0	1, 0, 3, 2
	x10	2, 3, 0, 1	2, 3, 0, 1
	x11	3, 0, 1, 2	3, 2, 1, 0
8	000	0 1 2 3 4 5 6 7	0 1 2 3 4 5 6 7
	001	1 2 3 4 5 6 7 0	1 0 3 2 5 4 7 6
	010	2 3 4 5 6 7 0 1	2 3 0 1 6 7 4 5
	011	3 4 5 6 7 0 1 2	3 2 1 0 7 6 5 4
	100	4 5 6 7 0 1 2 3	4 5 6 7 0 1 2 3
	101	5 6 7 0 1 2 3 4	5 4 7 6 1 0 3 2
	110	6 7 0 1 2 3 4 5	6 7 4 5 2 3 0 1
	111	7 0 1 2 3 4 5 6	7 6 5 4 3 2 1 0
Full Page (optional)	nnn	Cn, Cn+1, Cn+2,.....	not supported

### Refresh Mode

SDRAM has two refresh modes, Auto Refresh and Self Refresh. Auto Refresh is similar to the  $\overline{\text{CAS}}$ -before- $\overline{\text{RAS}}$  refresh of conventional DRAMs. All of banks must be precharged before applying any refresh mode. An on-chip address counter increments the word and the bank addresses and no bank information is required for both refresh modes.

The chip enters the Auto Refresh mode, when  $\overline{\text{RAS}}$  and  $\overline{\text{CAS}}$  are held low and CKE and  $\overline{\text{WE}}$  are held high at a clock timing. The mode restores word line after the refresh and no external precharge command is necessary. A minimum tRC time is required between two automatic refreshes in a burst refresh mode. The same rule applies to any access command after the automatic refresh operation.

The chip has an on-chip timer and the Self Refresh mode is available. It enters the mode when  $\overline{RAS}$ ,  $\overline{CAS}$ , and CKE are low and  $\overline{WE}$  is high at a clock timing. All of external control signals including the clock are disabled. Returning CKE to high enables the clock and initiates the refresh exit operation. After the exit command, at least one tRC delay is required prior to any access command.

#### DQM Function

DQM has two functions for data I/O read and write operations. During reads, when it turns to „high“ at a clock timing, data outputs are disabled and become high impedance after two clock delay (DQM Data Disable Latency  $t_{DQZ}$ ). It also provides a data mask function for writes. When DQM is activated, the write operation at the next clock is prohibited (DQM Write Mask Latency  $t_{DQW}$  = zero clocks).

#### Suspend Mode

During normal access mode, CKE is held high enabling the clock. When CKE is low, it freezes the internal clock and extends data read and write operations. One clock delay is required for mode entry and exit (Clock Suspend Latency  $t_{CSL}$ ).

#### Power Down

In order to reduce standby power consumption, a power down mode is available. All banks must be precharged and the necessary Precharge delay (trp) must occur before the SDRAM can enter the Power Down mode. Once the Power Down mode is initiated by holding CKE low, all of the receiver circuits except CLK and CKE are gated off. The Power Down mode does not perform any refresh operations, therefore the device can't remain in Power Down mode longer than the Refresh period (tref) of the device. Exit from this mode is performed by taking CKE „high“. One clock delay is required for mode entry and exit.

#### Auto Precharge

Two methods are available to precharge SDRAMs. In an automatic precharge mode, the CAS timing accepts one extra address, CA10, to determine whether the chip restores or not after the operation. If CA10 is high when a Read Command is issued, the **Read with Auto-Precharge** function is initiated. The SDRAM automatically enters the precharge operation one clock before the last data out for  $\overline{CAS}$  latencies 2 and two clocks for  $\overline{CAS}$  latencies 3. If CA10 is high when a Write Command is issued, the **Write with Auto-Precharge** function is initiated. The SDRAM automatically enters the precharge operation a time delay equal to  $t_{WR}$  (Write recovery time) after the last data in.

#### Precharge Command

There is also a separate precharge command available. When  $\overline{RAS}$  and  $\overline{WE}$  are low and  $\overline{CAS}$  is high at a clock timing, it triggers the precharge operation. Three address bits, BA0, BA1 and A10 are used to define banks as shown in the following list. The precharge command can be imposed one clock before the last data out for CAS latency = 2 and two clocks before the last data out for CAS latency = 3. Writes require a time delay  $t_{wr}$  from the last data out to apply the precharge command.

Bank Selection by Address Bits :

A10	BA0	BA1	
0	0	0	Bank 0
0	0	1	Bank 1
0	1	0	Bank 2
0	1	1	Bank 3
1	x	x	all Banks

**Burst Termination**

Once a burst read or write operation has been initiated, there are several methods in which to terminate the burst operation prematurely. These methods include using another Read or Write Command to interrupt an existing burst operation, use a Precharge Command to interrupt a burst cycle and close the active bank, or using the Burst Stop Command to terminate the existing burst operation but leave the bank open for future Read or Write Commands to the same page of the active bank. When interrupting a burst with another Read or Write Command care must be taken to avoid DQ contention. The Burst Stop Command, however, has the fewest restrictions making it the easiest method to use when terminating a burst operation before it has been completed. If a Burst Stop command is issued during a burst write operation, then any residual data from the burst write cycle will be ignored. Data that is presented on the DQ pins before the Burst Stop Command is registered will be written to the memory.

### Absolute Maximum Ratings

Operating temperature range .....0 to + 70 °C  
 Storage temperature range.....– 55 to + 150 °C  
 Input/output voltage .....– 0.3 to V<sub>dd</sub>+0.3 V  
 Power supply voltage V<sub>DD</sub> / V<sub>DDQ</sub>..... – 0.3 to + 4.6 V  
 Power Dissipation.....1 W  
 Data out current (short circuit) ..... 50 mA

**Note:** Stresses above those listed under “Absolute Maximum Ratings” may cause permanent damage of the device. Exposure to absolute maximum rating conditions for extended periods may affect device reliability.

### Recommended Operation and Characteristics for LV-TTL versions:

$T_A = 0$  to 70 °C;  $V_{SS} = 0$  V;  $V_{DD}, V_{DDQ} = 3.3$  V  $\pm$  0.3 V

Parameter	Symbol	Limit Values		Unit	Notes
		min.	max.		
Input high voltage	$V_{IH}$	2.0	V <sub>dd</sub> +0.3	V	1, 2
Input low voltage	$V_{IL}$	– 0.3	0.8	V	1, 2
Output high voltage ( $I_{OUT} = -4.0$ mA)	$V_{OH}$	2.4	–	V	
Output low voltage ( $I_{OUT} = 4.0$ mA)	$V_{OL}$	–	0.4	V	
Input leakage current, any input (0 V < $V_{IN}$ < V <sub>ddq</sub> , all other inputs = 0 V)	$I_{I(L)}$	– 5	5	μA	
Output leakage current (DQ is disabled, 0 V < $V_{OUT}$ < V <sub>dd</sub> )	$I_{O(L)}$	– 5	5	μA	

### Notes:

- All voltages are referenced to V<sub>SS</sub>.
- $V_{IH}$  may overshoot to V<sub>dd</sub> + 2.0 V for pulse width of < 4ns with 3.3V.  $V_{IL}$  may undershoot to –2.0 V for pulse width < 4.0 ns with 3.3V. Pulse width measured at 50% points with amplitude measured peak to DC reference.

### Capacitance

$T_A = 0$  to 70 °C;  $V_{DD} = 3.3$  V  $\pm$  0.3 V,  $f = 1$  MHz

Parameter	Symbol	Values		Unit
		min.	max.	
Input capacitance (CLK)	$C_{I1}$	2.5	4.0	pF
Input capacitance (A0-A12, BA0,BA1, $\overline{RAS}$ , $\overline{CAS}$ , $\overline{WE}$ , $\overline{CS}$ , CKE, DQM)	$C_{I2}$	2.5	5.0	pF
Input / Output capacitance (DQ)	$C_{IO}$	4.0	6.5	pF

### Operating Currents ( $T_A = 0$ to $70^\circ\text{C}$ , $V_{dd} = 3.3\text{V} \pm 0.3\text{V}$ )

(Recommended Operating Conditions unless otherwise noted)

Parameter & Test Condition		Symb.	-8/-8B	-10		Note	
			max.				
<b>OPERATING CURRENT</b>		ICC1					
trc=trcmin., tck=tckmin. Outputs open, Burst Length = 4, CL=3 All banks operated in random access, all banks operated in ping-pong manner to maximize gapless data access		x4	100	70	mA	3	
		x8	110	75	mA		
		x16	130	90	mA		
<b>PRECHARGE STANDBY CURRENT in Power Down Mode</b>							
	tck = min.	ICC2P	2	2	mA	3	
	$\overline{\text{CS}} = \text{VIH}(\text{min.}), \text{CKE} \leq \text{Vil}(\text{max})$	ICC2PS	1	1	mA	3	
<b>PRECHARGE STANDBY CURRENT in Non-Power Down Mode</b>							
	tck = min.	ICC2N	35	30	mA	3	
	$\overline{\text{CS}} = \text{VIH}(\text{min.}), \text{CKE} \geq \text{Vih}(\text{min})$	ICC2NS	5	5	mA	3	
<b>NO OPERATING CURRENT</b>							
	$\text{CKE} \geq \text{VIH}(\text{min.})$	ICC3N	45	40	mA	3	
	tck = min., $\overline{\text{CS}} = \text{VIH}(\text{min})$ , active state ( max. 4 banks)	$\text{CKE} \leq \text{VIL}(\text{max.})$	ICC3P	8	8	mA	3
<b>BURST OPERATING CURRENT</b>		ICC4					
tck = min., Read command cycling		x4	60	40	mA	3,4	
		x8	70	50	mA		
		x16	100	70	mA		
<b>AUTO REFRESH CURRENT</b>		ICC5	130	90	mA	3	
tck = min., Auto Refresh command cycling							
<b>SELF REFRESH CURRENT</b>							
Self Refresh Mode, $\text{CKE} = 0.2\text{V}$		standard version	1	1	mA	3	
		L-version	500	500	$\mu\text{A}$	3	

### Notes:

- These parameters depend on the cycle rate. These values are measured at 100 MHz for -8 and at 66 MHz for -10 parts. Input signals are changed once during tck, excepts for ICC6 and for standby currents when tck=infinity.
- These parameters are measured with continuous data stream during read access and all DQ toggling. CL=3 and BL=4 is assumed and the VDDQ current is excluded.

### AC Characteristics 1)2)

$T_A = 0$  to  $70$  °C;  $V_{SS} = 0$  V;  $V_{DD} = 3.3$  V  $\pm$  0.3 V,  $t_T = 1$  ns

Parameter	Symbol	Limit Values						Unit
		-8		-8B		-10		
		min.	max.	min.	max.	min.	max.	

### Clock and Clock Enable

Clock Cycle Time	$\overline{\text{CAS}}$ Latency = 3	$t_{CK}$	8	–	10	–	10	–	ns	
	$\overline{\text{CAS}}$ Latency = 2	$t_{CK}$	10	–	12	–	15	–	ns	
Clock Frequency	$\overline{\text{CAS}}$ Latency = 3	$t_{CK}$	–	125	–	100	–	100	MHz	
	$\overline{\text{CAS}}$ Latency = 2	$t_{CK}$	–	100	–	83	–	66	MHz	
Access Time from Clock	$\overline{\text{CAS}}$ Latency = 3	$t_{AC}$	–	6		6	–	7	ns	2, 3
	$\overline{\text{CAS}}$ Latency = 2	$t_{AC}$	–	6		7	–	8	ns	
Clock High Pulse Width		$t_{CH}$	3	–	3	–	3	–	ns	
Clock Low Pulse Width		$t_{CL}$	3	–	3	–	3	–	ns	
Transition time		$t_T$	0.5	10	0.5	10	0.5	10	ns	

### Setup and Hold Times

Input Setup Time	$t_{IS}$	2	–	2	–	2.5	–	ns	4
Input Hold Time	$t_{IH}$	1	–	1	–	1	–	ns	4
CKE Setup Time	$t_{CKS}$	2	–	2	–	2.5	–	ns	4
CKE Hold Time	$t_{CKH}$	1	–	1	–	1	–	ns	4
Mode Register Set-up time	$t_{RSC}$	16	–	20	–	20	–	ns	
Power Down Mode Entry Time	$t_{SB}$	0	8	0	10	0	10	ns	

### Common Parameters

Row to Column Delay Time	$t_{RCD}$	20	–	20	–	30	–	ns	5
Row Precharge Time	$t_{RP}$	20	–	30	–	30	–	ns	5
Row Active Time	$t_{RAS}$	50	100k	60	100k	60	100k	ns	5
Row Cycle Time	$t_{RC}$	70	–	80	–	90	–	ns	5
Activate(a) to Activate(b) Command period	$t_{RRD}$	16	–	20	–	20	–	ns	5
$\overline{\text{CAS}}$ (a) to $\overline{\text{CAS}}$ (b) Command period	$t_{CCD}$	1	–	1	–	1	–	CLK	



Parameter	Symbol	Limit Values						Unit
		-8		-8B		-10		
		min.	max.	min.	max.	min.	max.	

### Refresh Cycle

Refresh Period (4096 cycles)	$t_{REF}$	–	64	–	64	–	64	ms	
Self Refresh Exit Time	$t_{SREX}$	10	–	10	–	10	–	ns	

### Read Cycle

Data Out Hold Time	$t_{OH}$	3	–	3	–	3	–	ns	2
Data Out to Low Impedance Time	$t_{LZ}$	0	–	0	–	0	–	ns	
Data Out to High Impedance Time	$t_{HZ}$	3	8	3	10	3	10	ns	
DQM Data Out Disable Latency	$t_{DQZ}$	–	2	–	2	–	2	CLK	

### Write Cycle

Data Input to Precharge (write recovery)	$t_{WR}$	2	–	2	–	2	–	CLK	
DQM Write Mask Latency	$t_{DQW}$	0	–	0	–	0	–	CLK	

### Notes for AC Parameters:

1. For proper power-up see the operation section of this data sheet.
2. AC timing tests for LV-TTL versions have  $V_{il} = 0.4\text{ V}$  and  $V_{ih} = 2.4\text{ V}$  with the timing referenced to the 1.5 V crossover point. The transition time is measured between  $V_{ih}$  and  $V_{il}$ . All AC measurements assume  $t_T = 1\text{ ns}$  with the AC output load circuit shown in fig.1. Specified  $t_{ac}$  and  $t_{oh}$  parameters are measured with a 50 pF only, without any resistive termination and with a input signal of 1V / ns edge rate between 0.8V and 2.0 V..

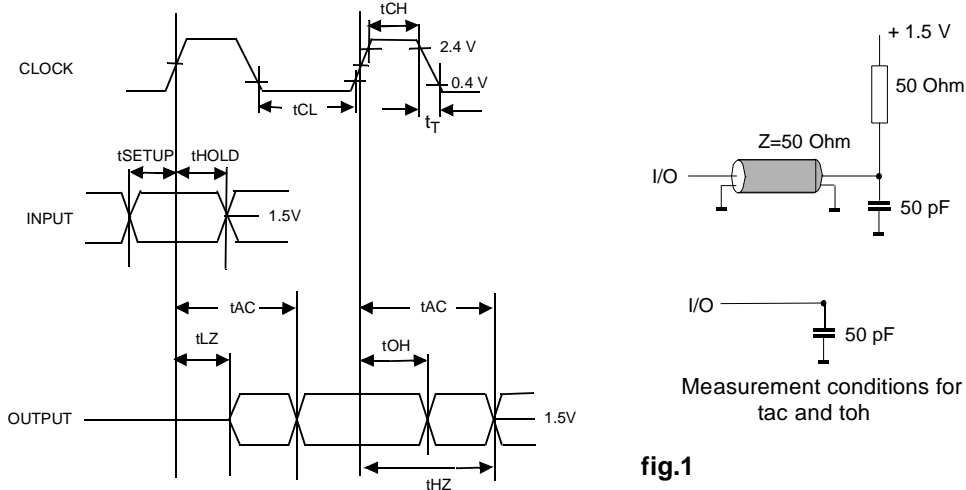

fig.1

3. If clock rising time is longer than 1 ns, a time  $(t_T/2 - 0.5)$  ns has to be added to this parameter.
4. If  $t_T$  is longer than 1 ns, a time  $(t_T - 1)$  ns has to be added to this parameter.
5. These parameter account for the number of clock cycle and depend on the operating frequency of the clock, as follows:

*the number of clock cycle = specified value of timing period (counted in fractions as a whole number)*

Self Refresh Exit is a synchronous operation and begins on the 2nd positive clock edge after CKE returns high. Self Refresh Exit is not complete until a time period equal to  $t_{RC}$  is satisfied once the Self Refresh Exit command is registered.

### Package Outlines

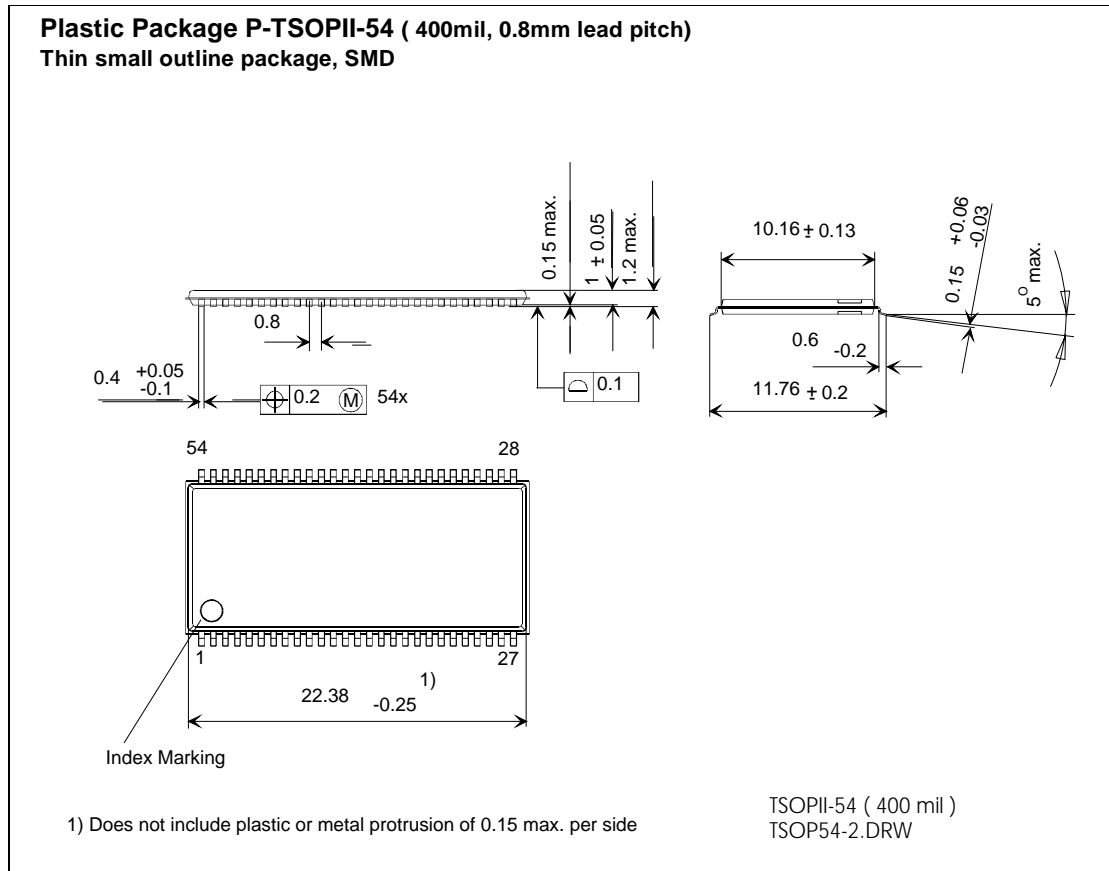

## Timing Diagrams

1. Bank Activate Command Cycle
2. Burst Read Operation
3. Read Interrupted by a Read
4. Read to Write Interval
  - 4.1 Read to Write Interval
  - 4.2 Minimum Read to Write Interval
  - 4.3 Non-Minimum Read to Write Interval
5. Burst Write Operation
6. Write and Read Interrupt
  - 6.1 Write Interrupted by a Write
  - 6.2 Write Interrupted by Read
7. Burst Write & Read with Auto-Precharge
  - 7.1 Burst Write with Auto-Precharge
  - 7.2 Burst Read with Auto-Precharge
8. Burst Termination
  - 8.1 Termination of a full Page Burst Write Operation
  - 8.2 Termination of a full Page Burst Write Operation
9. AC- Parameters
  - 9.1 AC Parameters for a Write Timing
  - 9.2 AC Parameters for a Read Timing
10. Mode Register Set
11. Power on Sequence and Auto Refresh (CBR)
12. Clock Suspension (using CKE)
  12. 1 Clock Suspension During Burst Read  $\overline{\text{CAS}}$  Latency = 2
  12. 2 Clock Suspension During Burst Read  $\overline{\text{CAS}}$  Latency = 3
  12. 3 Clock Suspension During Burst Write  $\overline{\text{CAS}}$  Latency = 2
  12. 4 Clock Suspension During Burst Write  $\overline{\text{CAS}}$  Latency = 3
13. Power Down Mode and Clock Suspend
14. Self Refresh ( Entry and Exit )
15. Auto Refresh ( CBR )
16. Random Column Read ( Page within same Bank)
  - 16.1  $\overline{\text{CAS}}$  Latency = 2
  - 16.2  $\overline{\text{CAS}}$  Latency = 3
17. Random Column Write ( Page within same Bank)
  - 17.1  $\overline{\text{CAS}}$  Latency = 2
  - 17.2  $\overline{\text{CAS}}$  Latency = 3

## Timing Diagrams (cont'd)

### 18. Random Row Read ( Interleaving Banks) with Precharge

18.1  $\overline{\text{CAS}}$  Latency = 2

18.2  $\overline{\text{CAS}}$  Latency = 3

### 19. Random Row Write ( Interleaving Banks) with Precharge

19.1  $\overline{\text{CAS}}$  Latency = 2

19.2  $\overline{\text{CAS}}$  Latency = 3

### 20. Full Page Read Cycle

20.1  $\overline{\text{CAS}}$  Latency = 2

20.2  $\overline{\text{CAS}}$  Latency = 3

### 21. Full Page Write Cycle

21.1  $\overline{\text{CAS}}$  Latency = 2

21.2  $\overline{\text{CAS}}$  Latency = 3

### 22. Precharge Termination of a Burst

22.1  $\overline{\text{CAS}}$  Latency = 2

22.2  $\overline{\text{CAS}}$  Latency = 3

## 1. Bank Activate Command Cycle

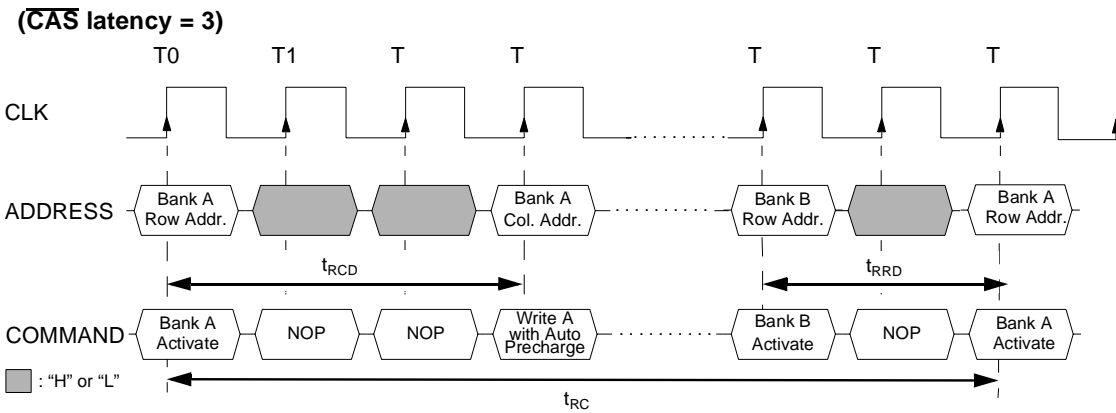

## 2. Burst Read Operation

(Burst Length = 4,  $\overline{\text{CAS}}$  latency = 2, 3)

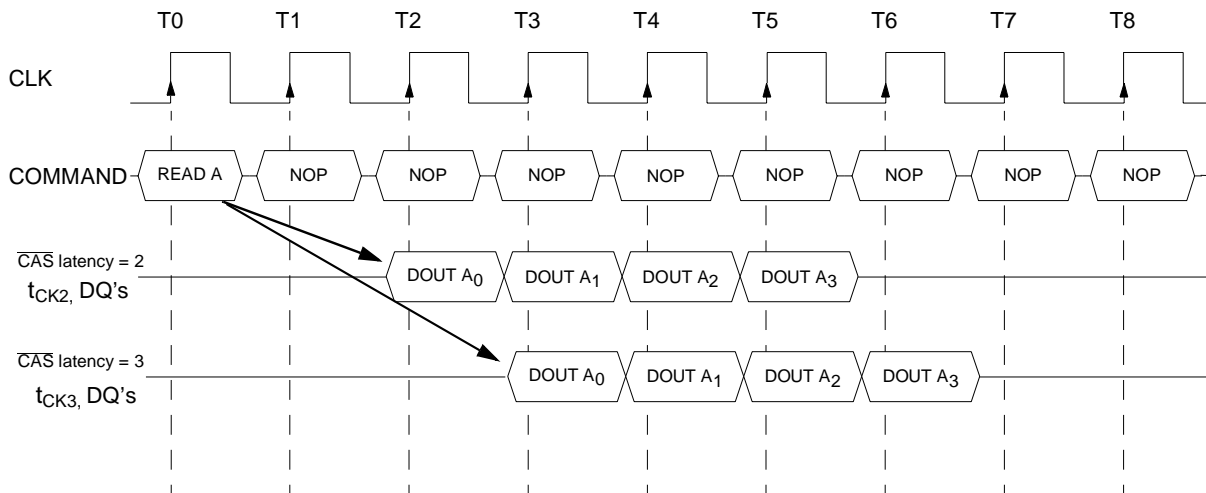

### 3. Read Interrupted by a Read

(Burst Length = 4,  $\overline{\text{CAS}}$  latency = 2, 3)

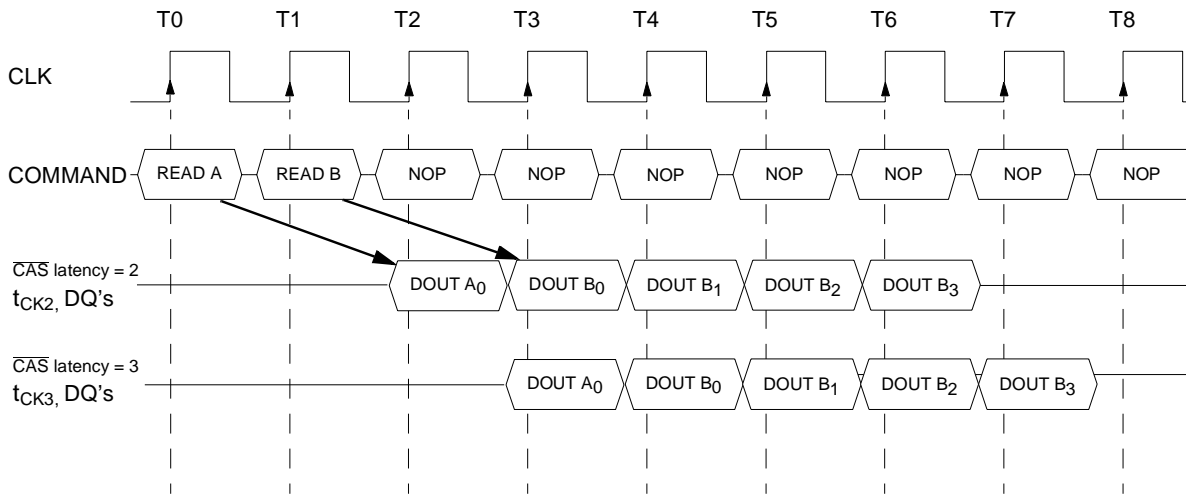

### 4.1 Read to Write Interval

(Burst Length = 4,  $\overline{\text{CAS}}$  latency = 3)

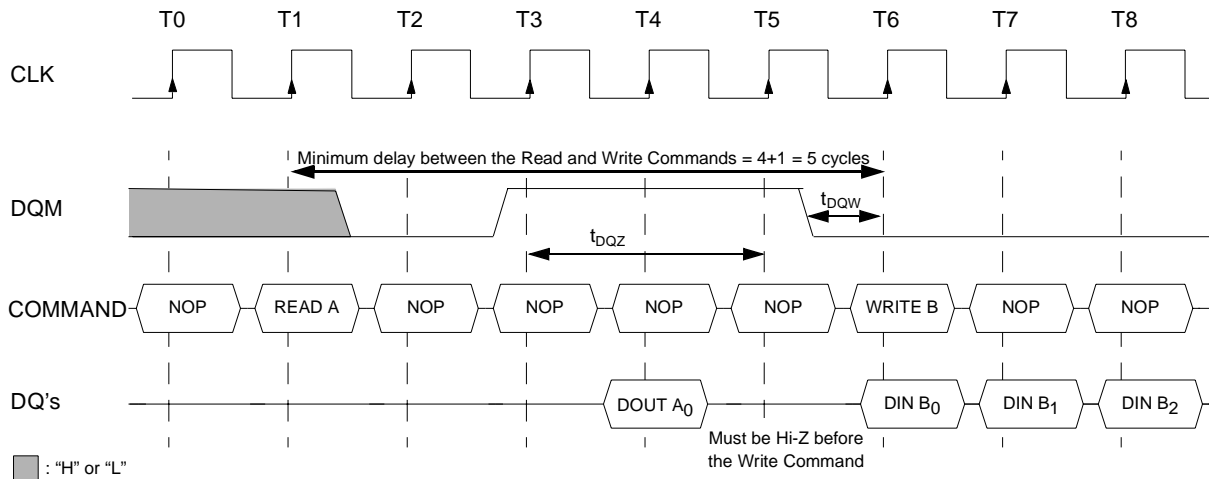

### 4.2. Minimum Read to Write Interval

(Burst Length = 4,  $\overline{\text{CAS}}$  latency = 2)

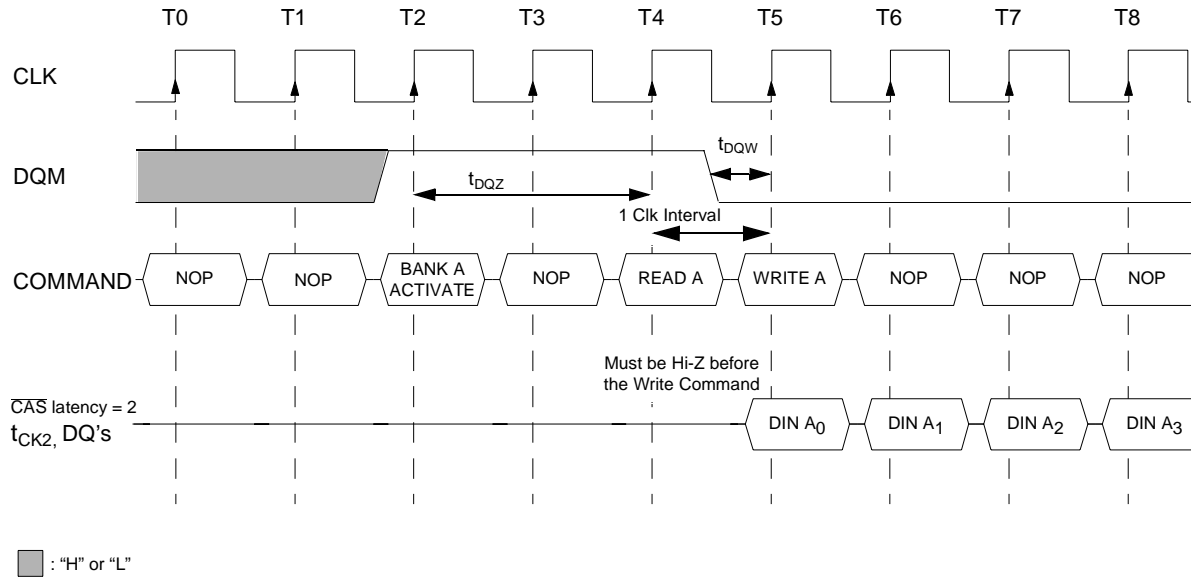

### 4.3. Non-Minimum Read to Write Interval

(Burst Length = 4,  $\overline{\text{CAS}}$  latency = 2, 3)

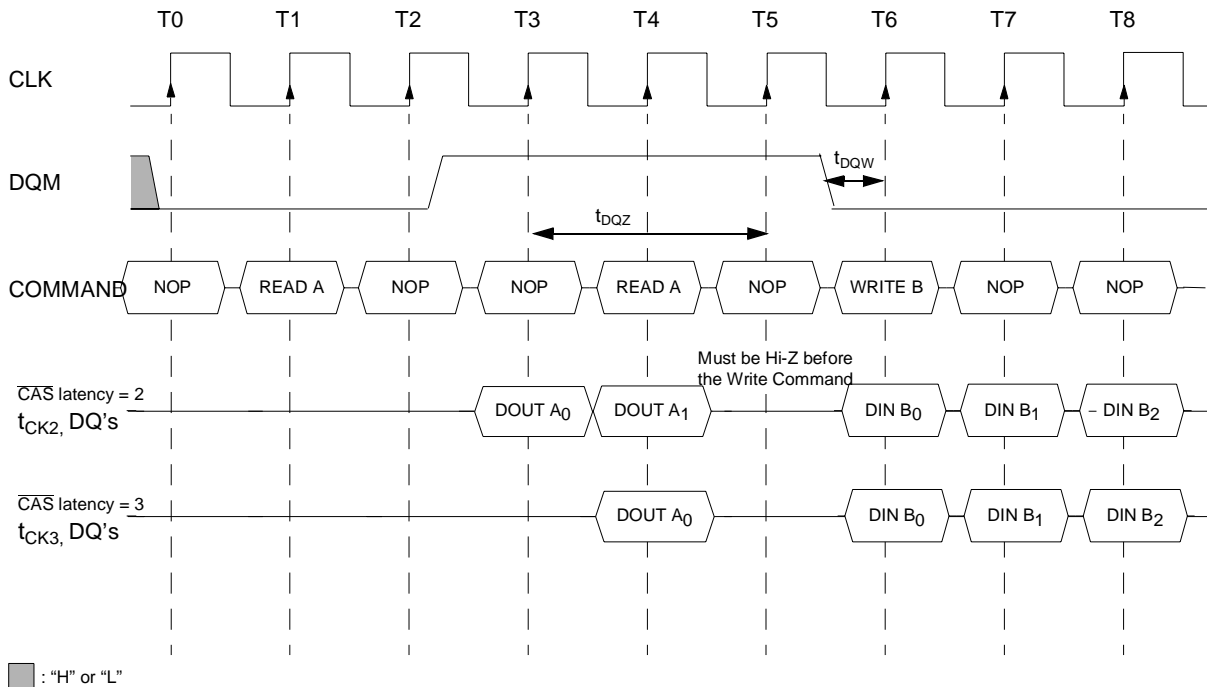



## 5. Burst Write Operation

(Burst Length = 4,  $\overline{\text{CAS}}$  latency = 2, 3)

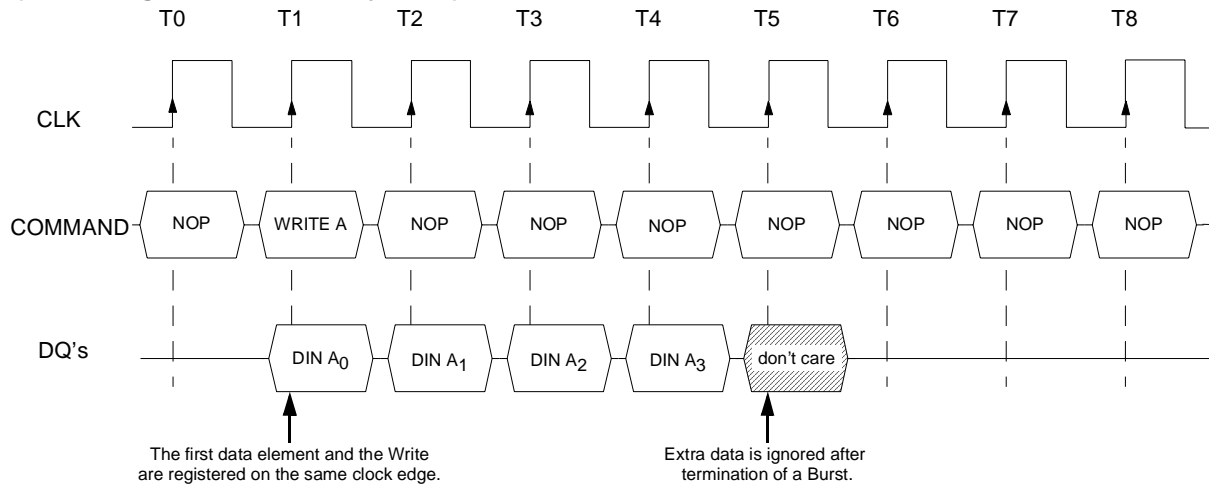

## 6.1 Write Interrupted by a Write

(Burst Length = 4,  $\overline{\text{CAS}}$  latency = 2, 3)

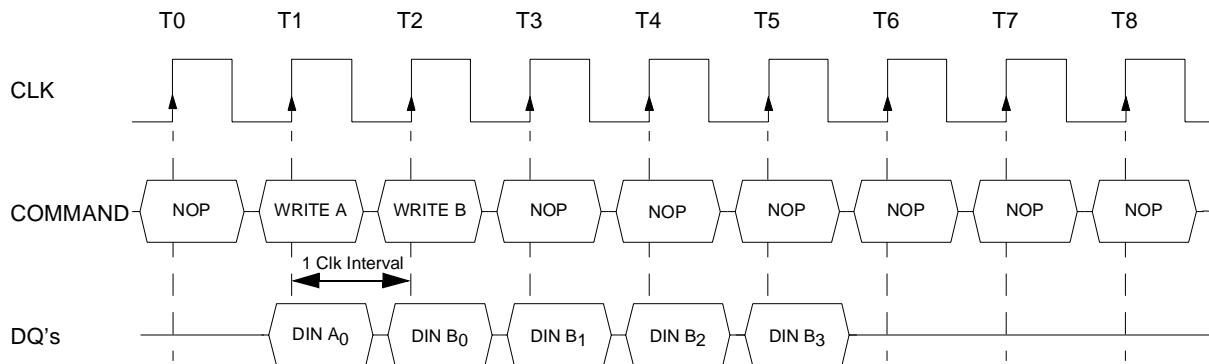

### 6.2 Write Interrupted by a Read

(Burst Length = 4,  $\overline{\text{CAS}}$  latency = 2, 3)

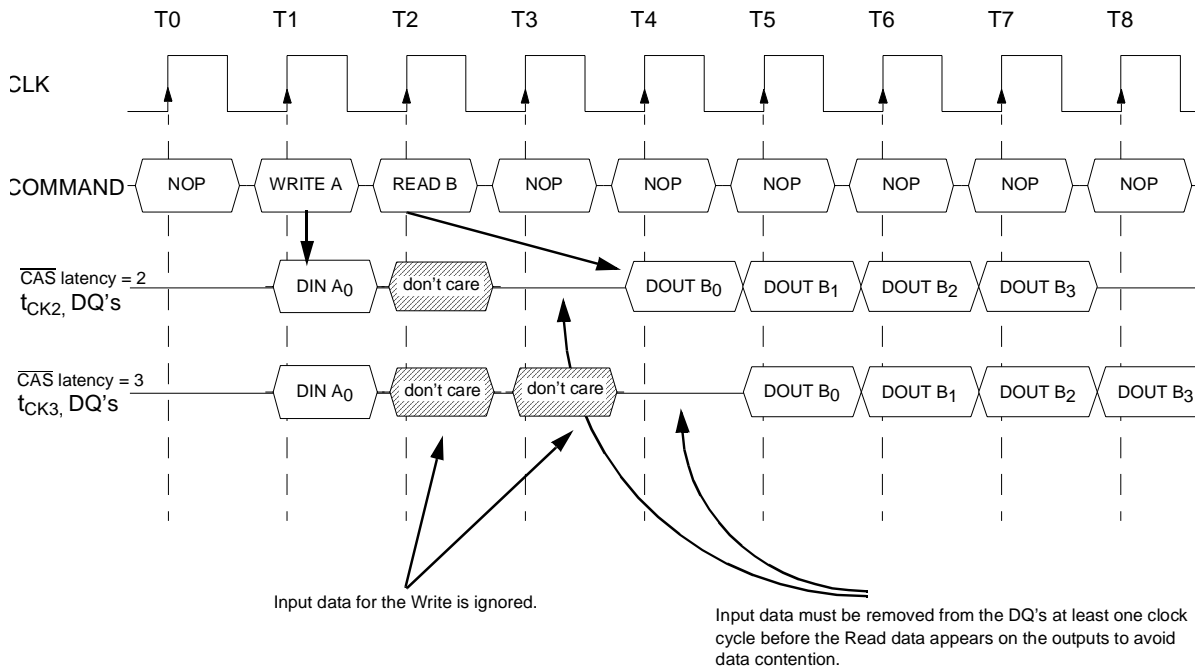

### 7.1 Burst Write with Auto-Precharge

Burst Length = 2,  $\overline{\text{CAS}}$  latency = 2, 3)

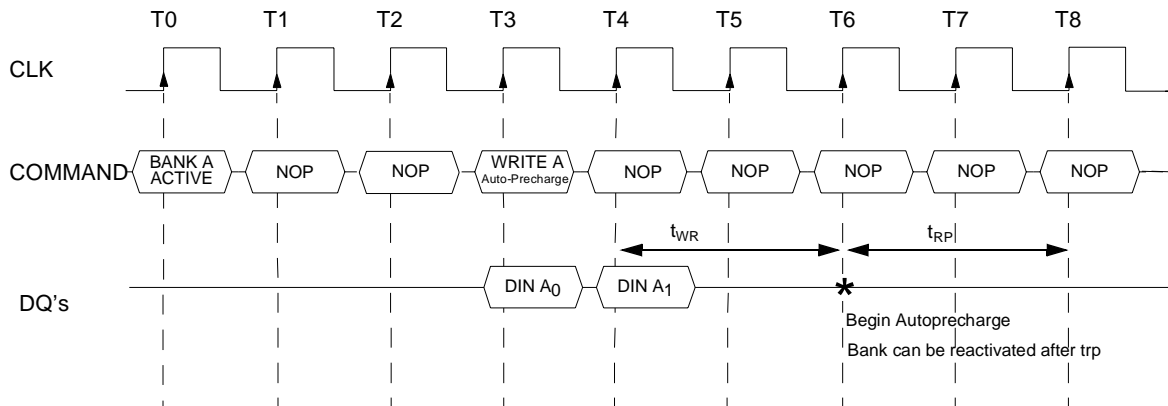

## 7.2 Burst Read with Auto-Precharge

(Burst Length = 4,  $\overline{\text{CAS}}$  latency = 2, 3)

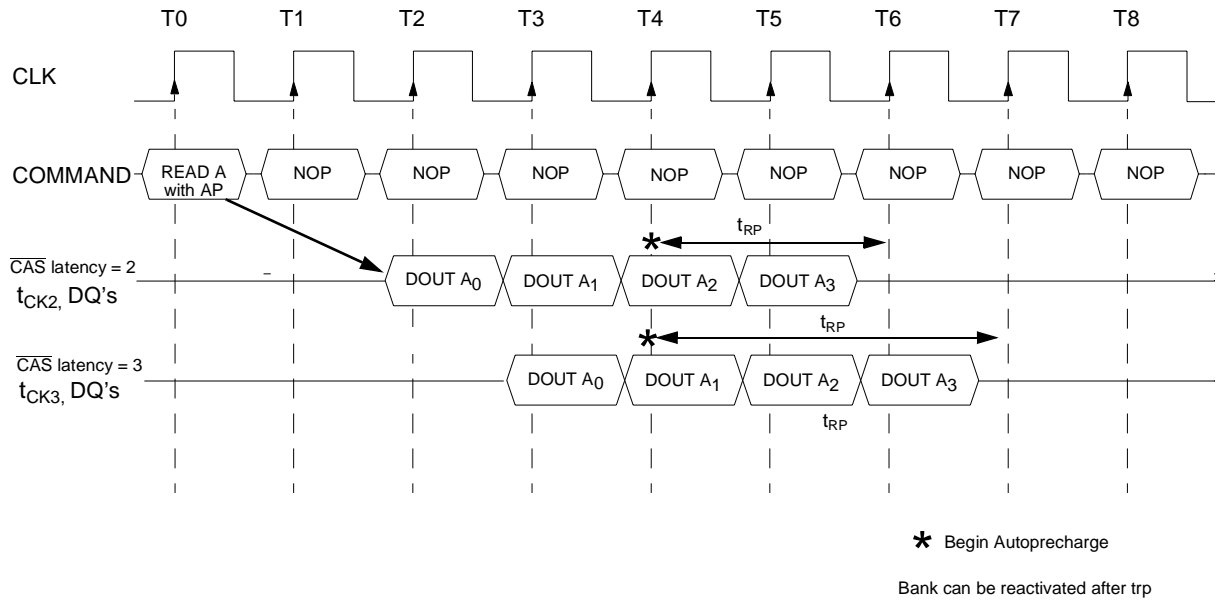

## 8.1 Termination of a Full Page Burst Read Operation

( $\overline{\text{CAS}}$  latency = 2, 3)

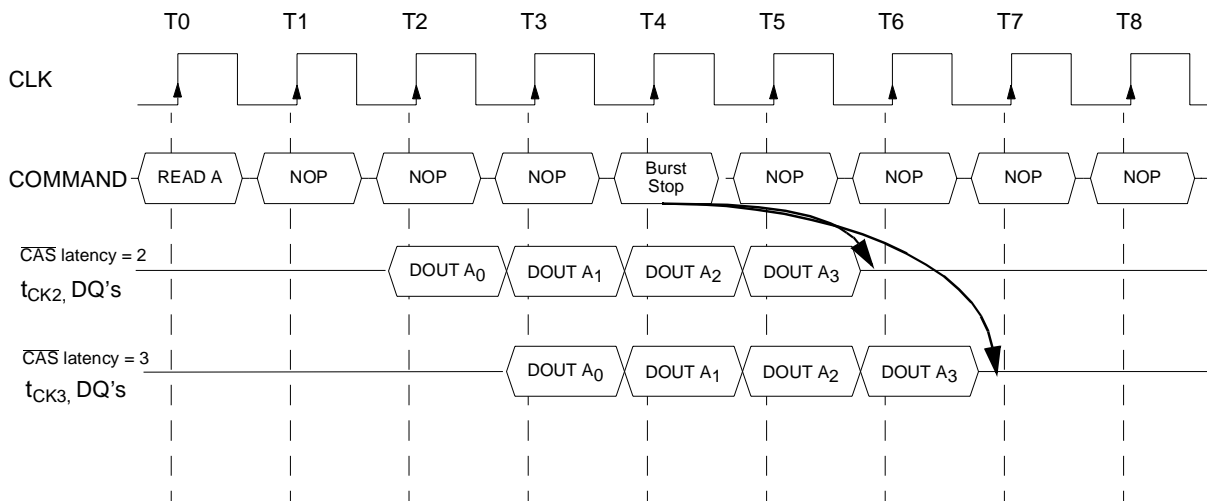

The burst ends after a delay equal to the  $\overline{\text{CAS}}$  latency.

## 8.2 Termination of a Full Page Burst Write Operation

(CAS Latency = 2, 3)

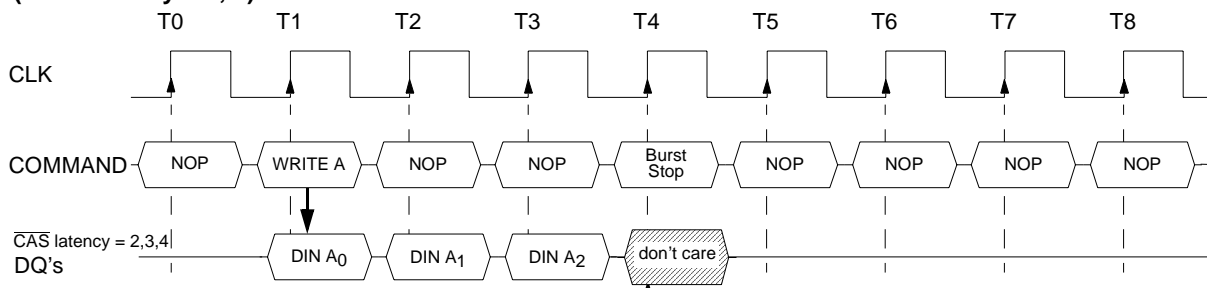

Input data for the Write is masked.

### 9.1 AC Parameters for Write Timing

Burst Length = 4,  $\overline{\text{CAS}}$  Latency = 2

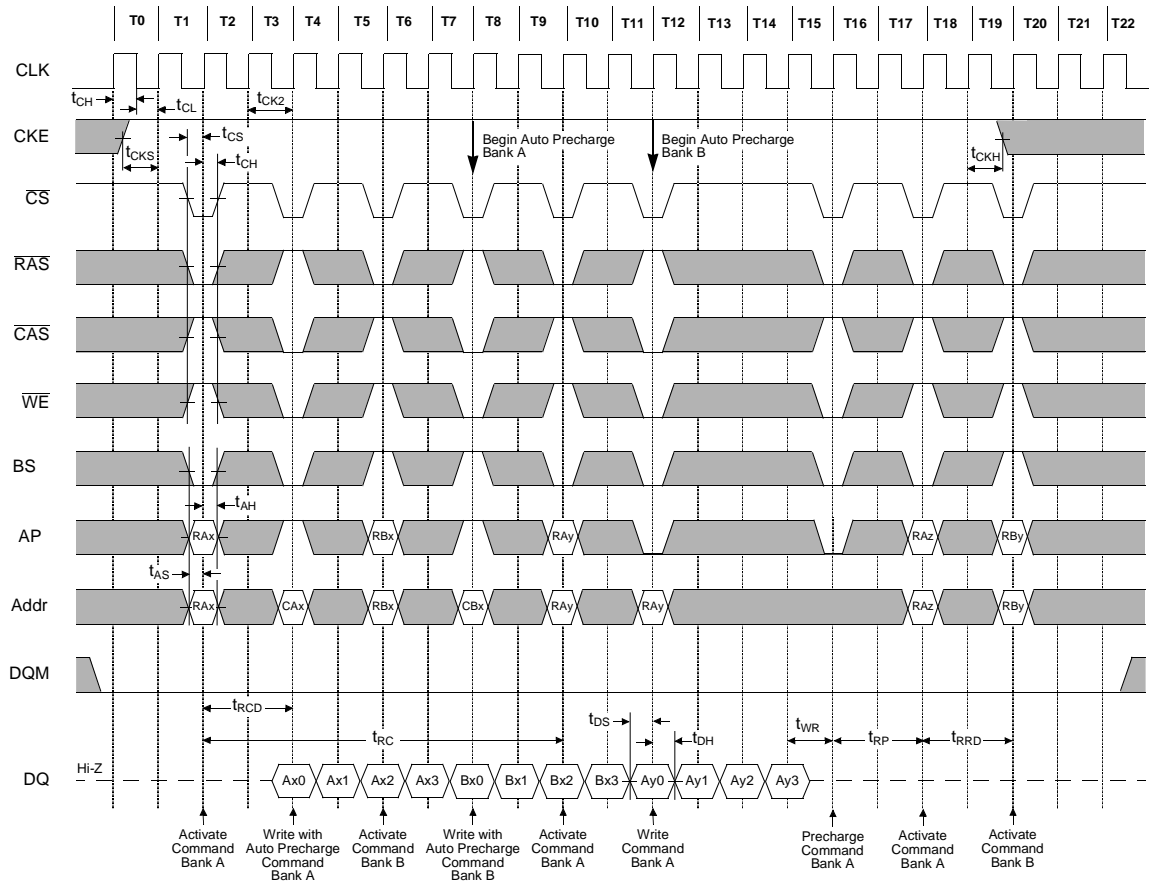

### 9.2 AC Parameters for Read Timing

Burst Length = 2,  $\overline{\text{CAS}}$  Latency = 2

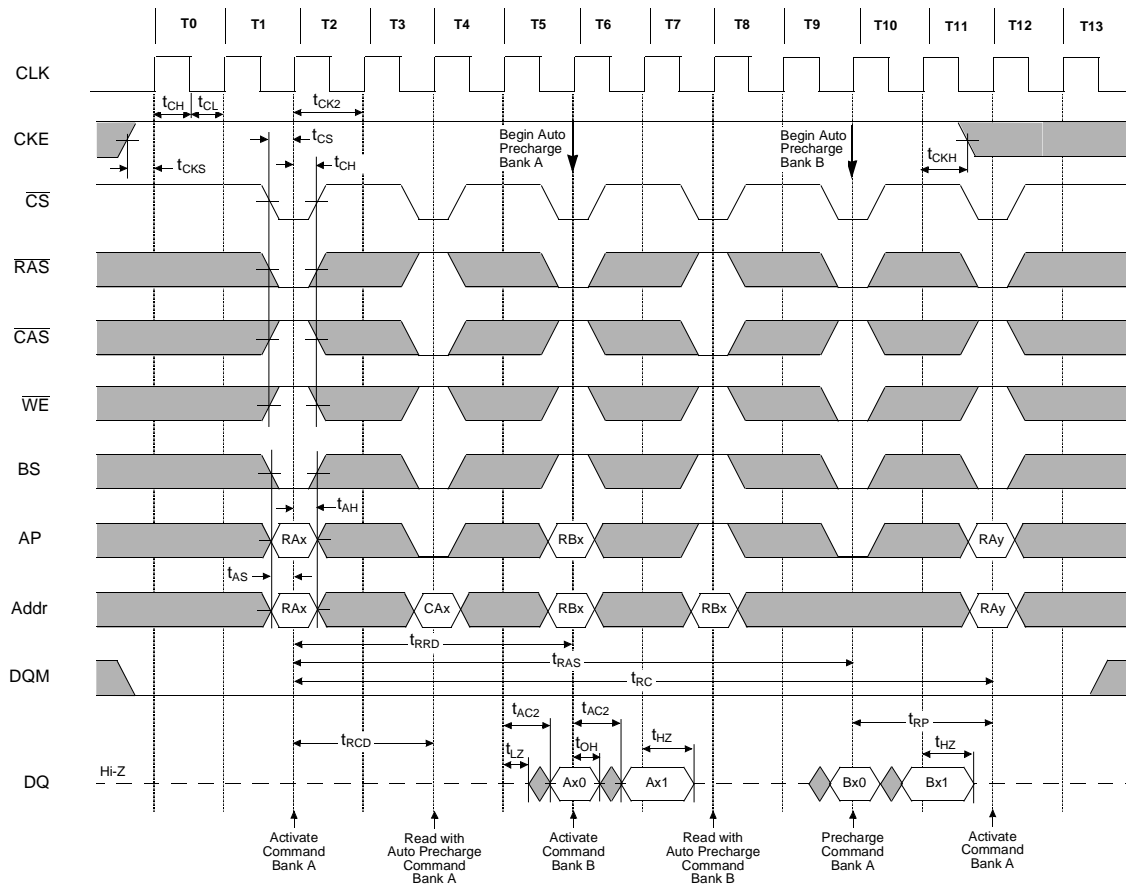

### 10. Mode Register Set

CAS Latency = 2

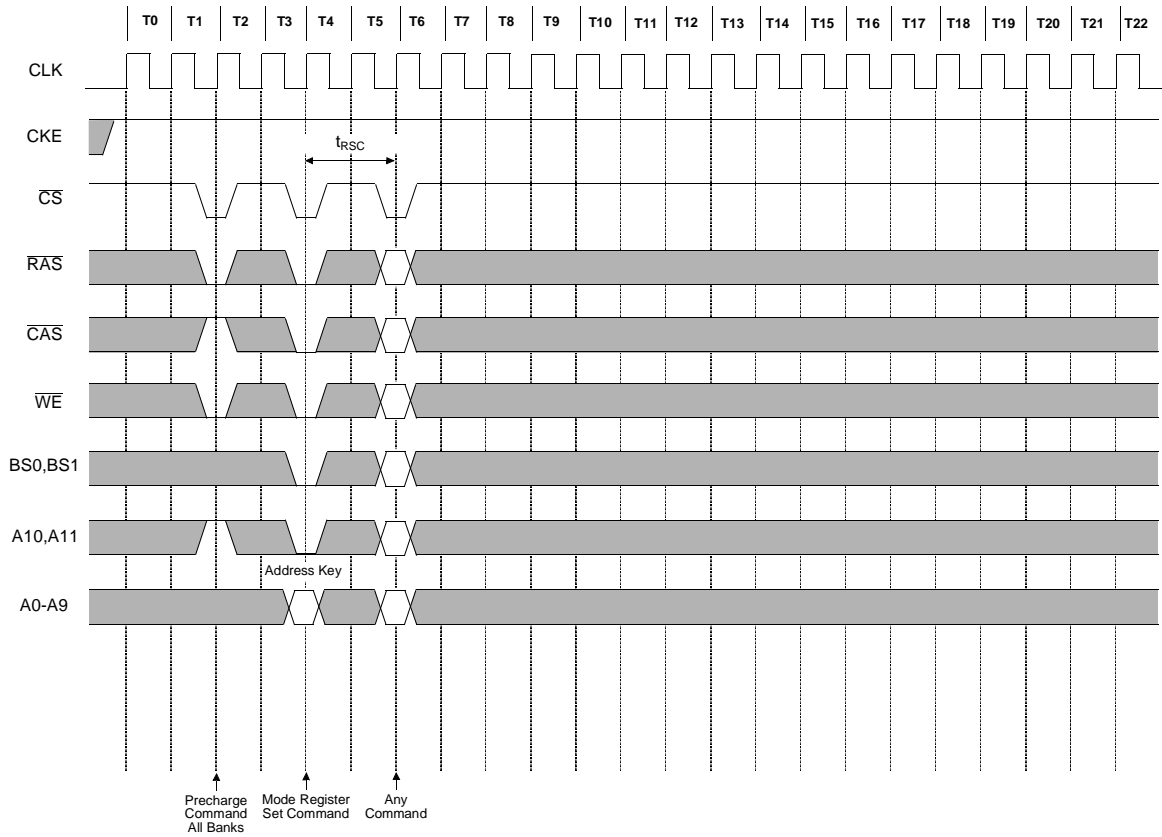

### 11. Power on Sequence and Auto Refresh (CBR)

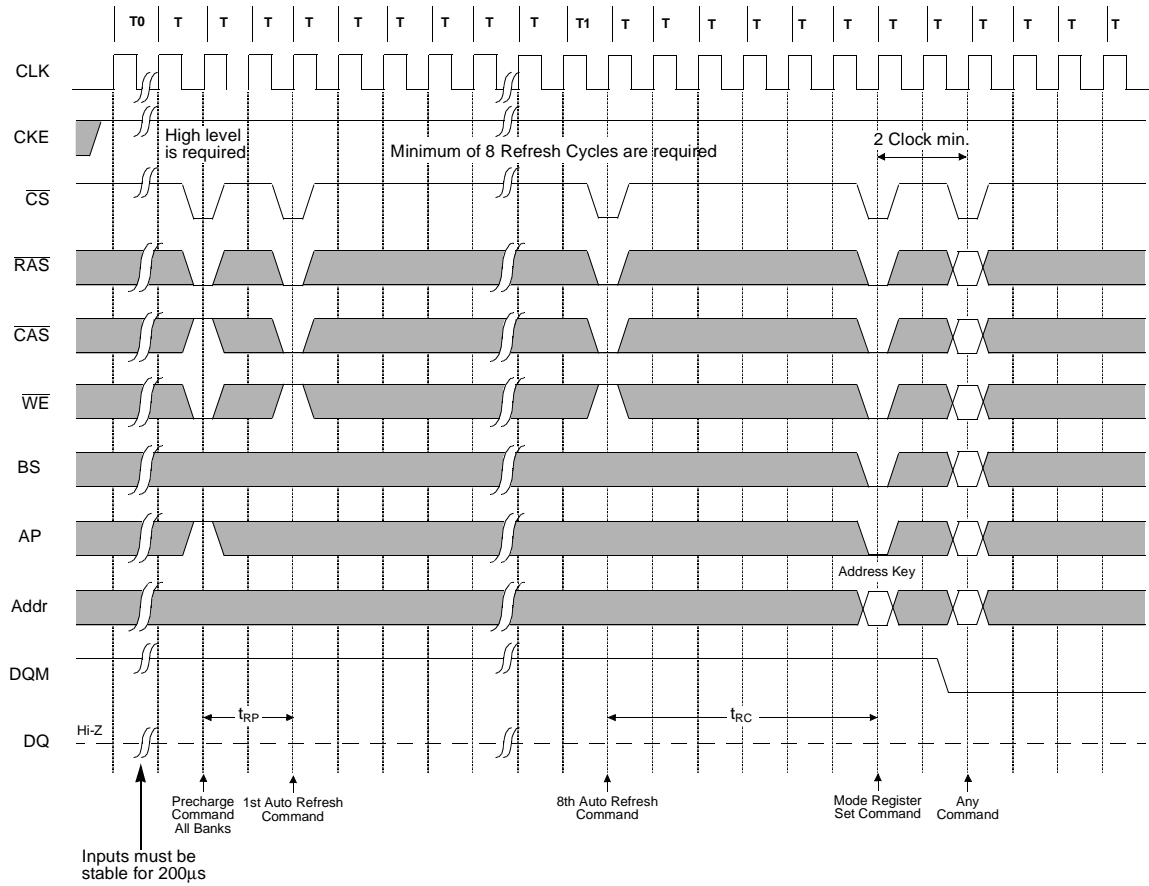



### 12.1 Clock Suspension During Burst Read (Using CKE)

Burst Length = 4,  $\overline{\text{CAS}}$  Latency = 2

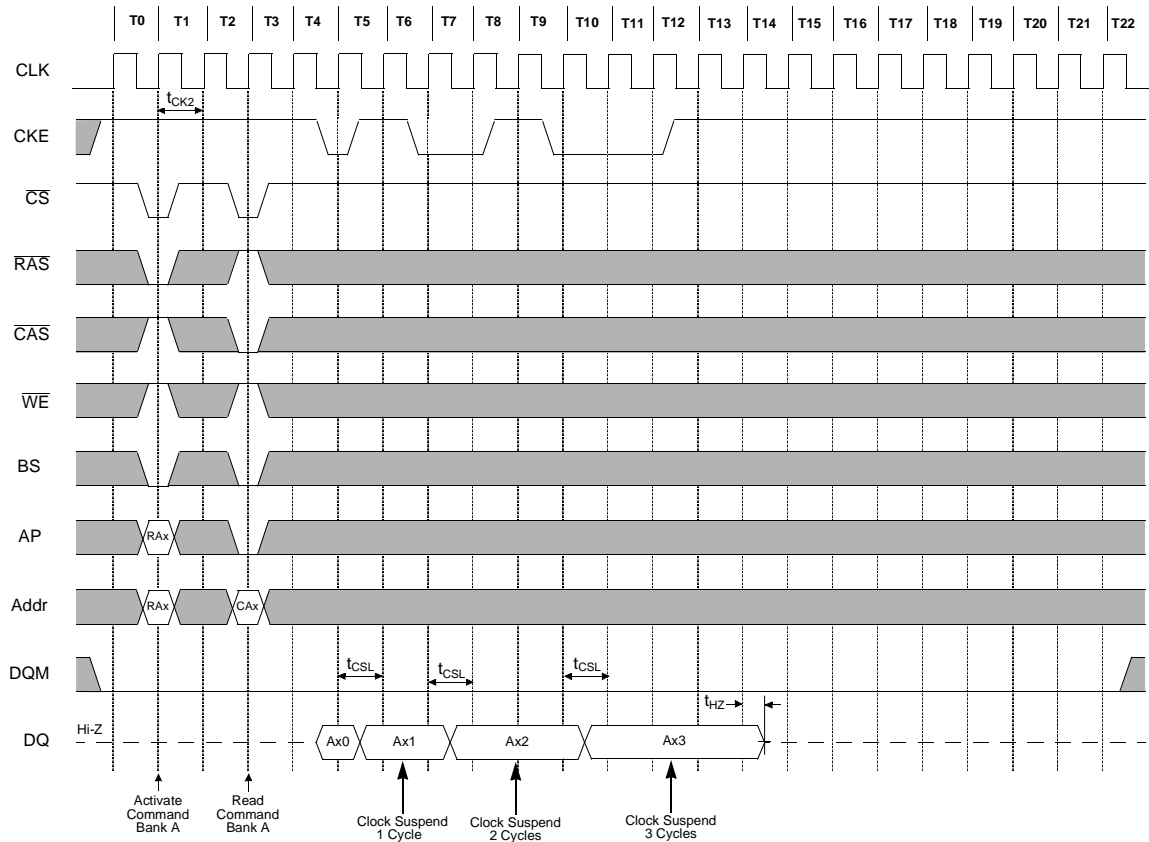

## 12.2 Clock Suspension During Burst Read (Using CKE)

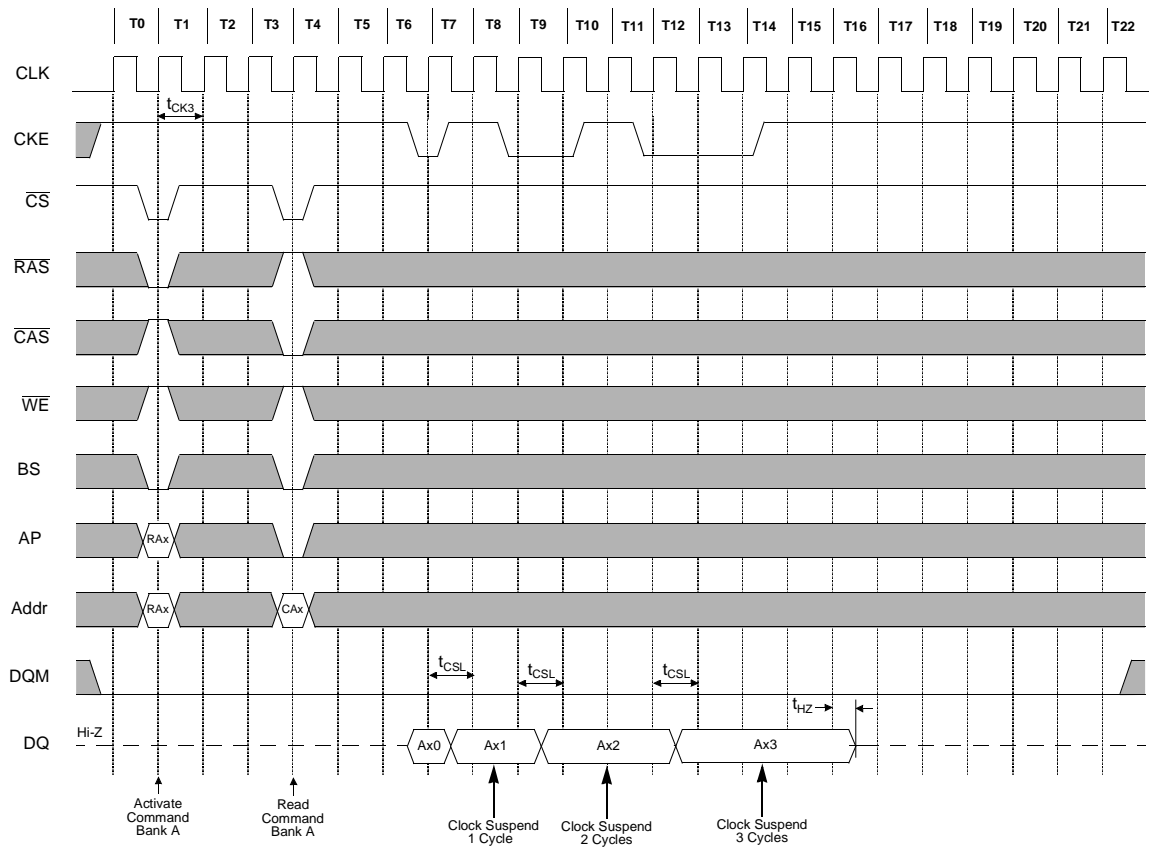
Burst Length = 4,  $\overline{\text{CAS}}$  Latency = 3

### 12.3 Clock Suspension During Burst Write (Using CKE)

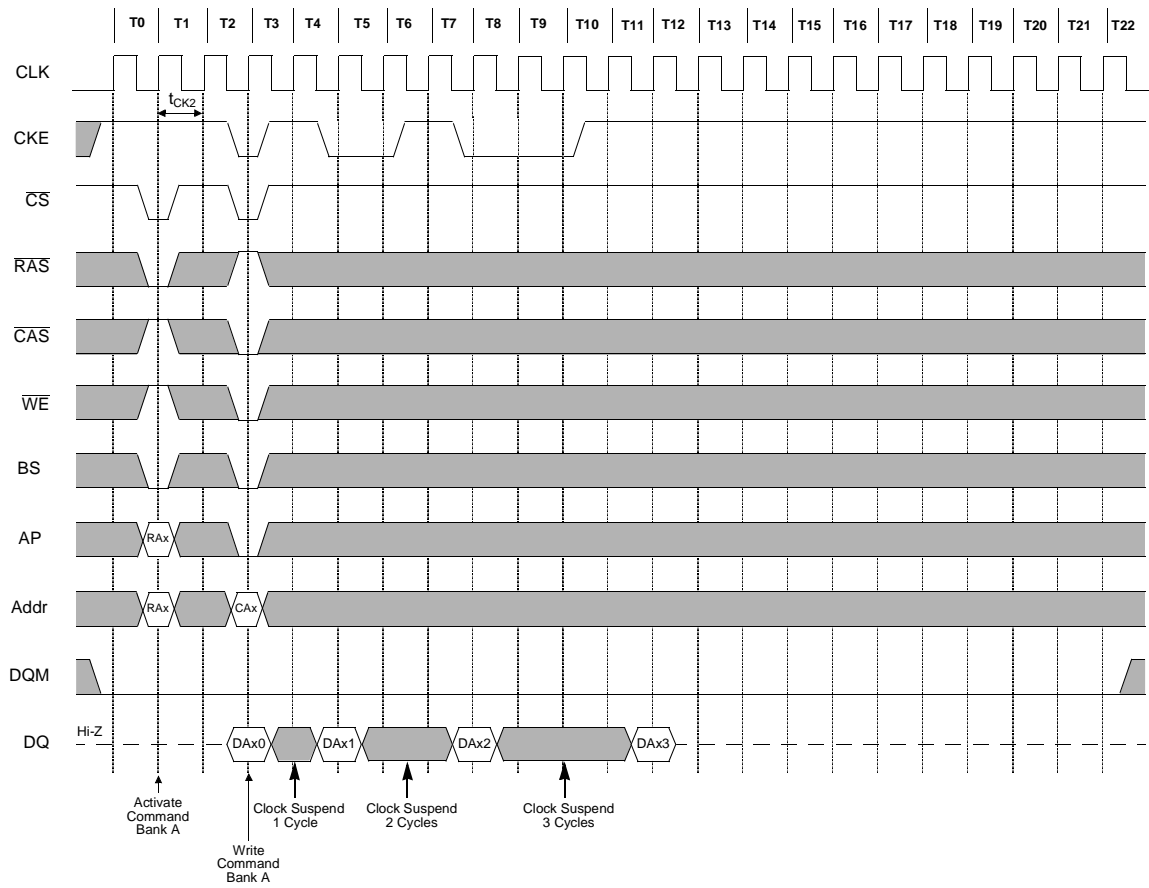
Burst Length = 4,  $\overline{\text{CAS}}$  Latency = 2

### 12.4 Clock Suspension During Burst Write (Using CKE)

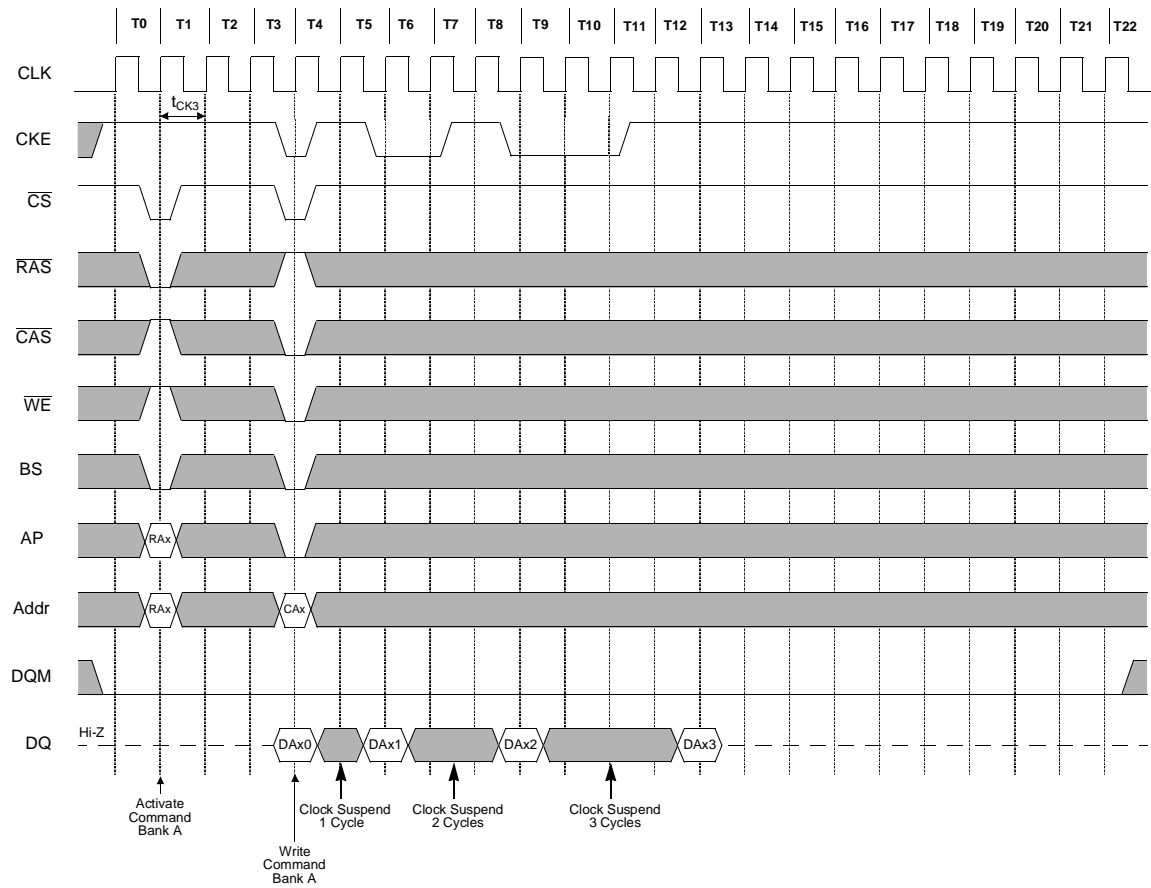
Burst Length = 4,  $\overline{\text{CAS}}$  Latency = 3

### 13. Power Down Mode and Clock Suspend

Burst Length = 4,  $\overline{\text{CAS}}$  Latency = 2

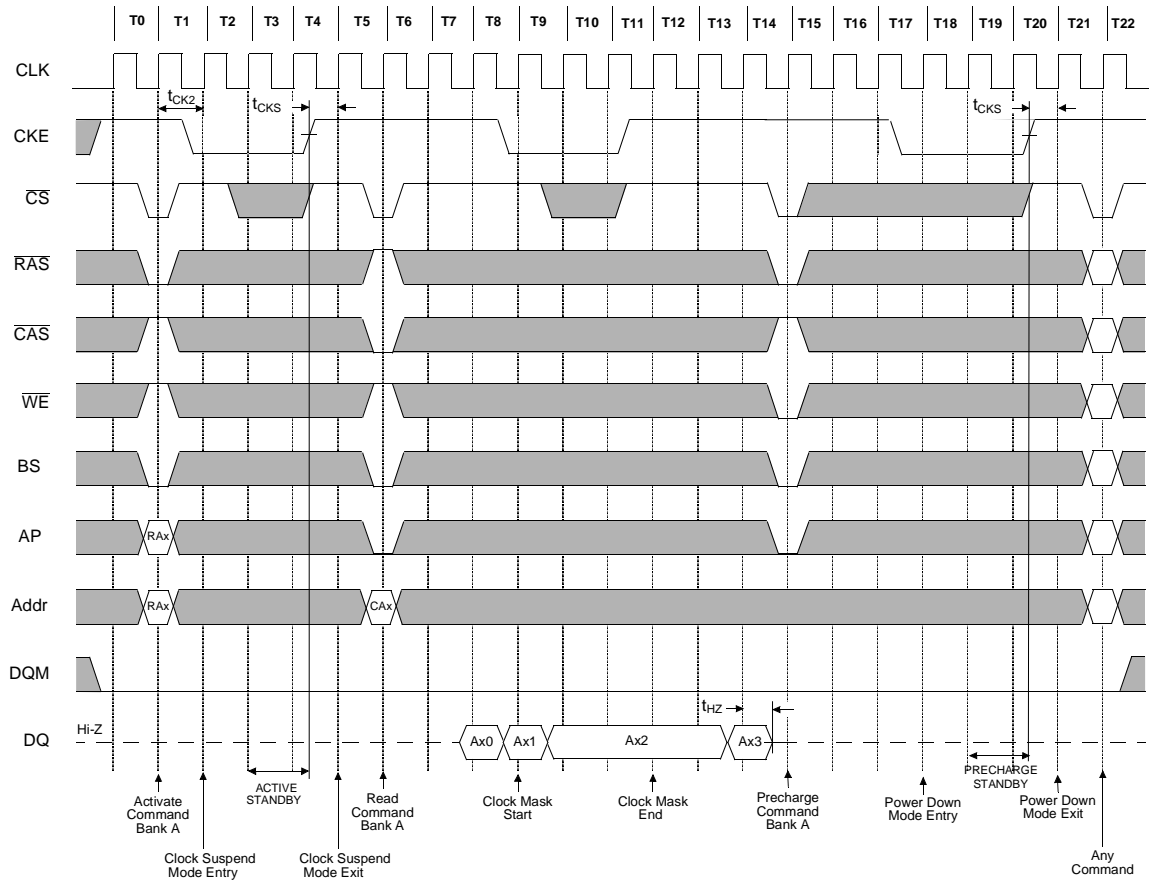

### 14. Self Refresh (Entry and Exit)

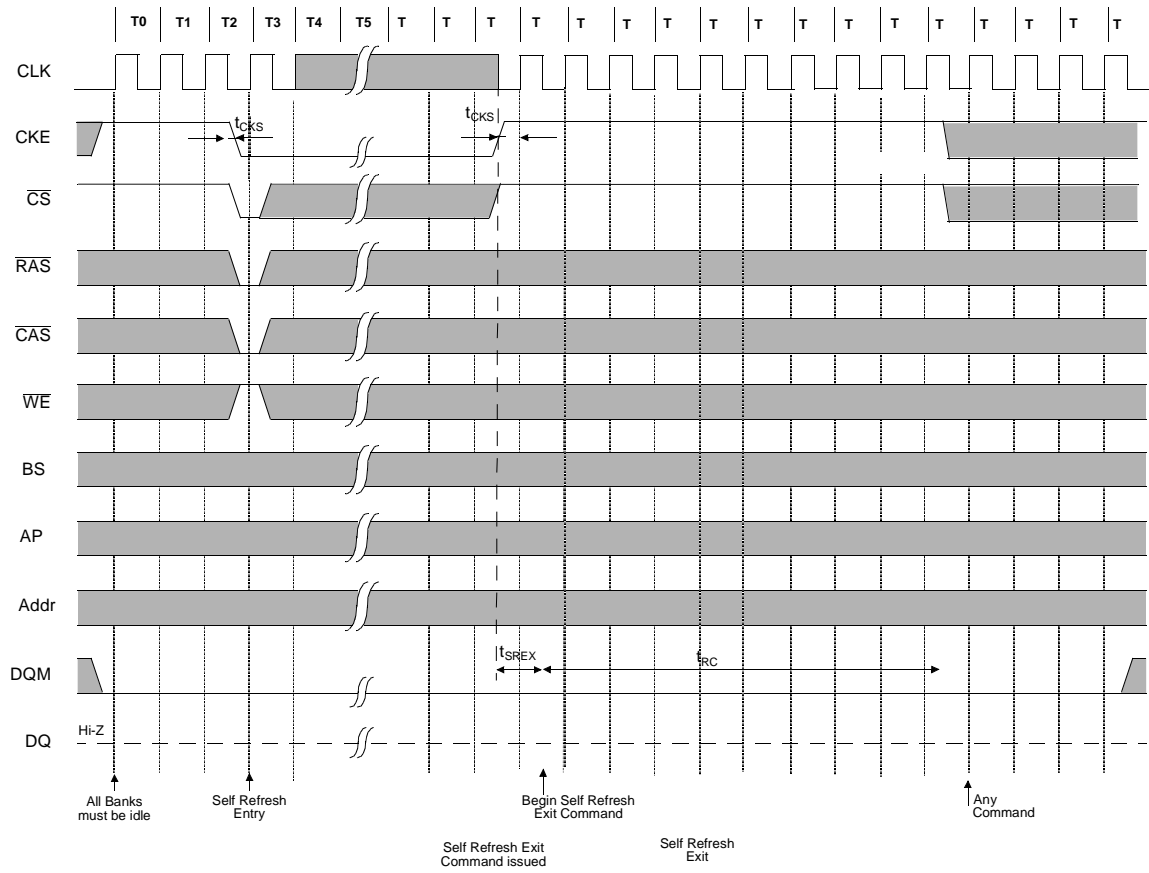

### 15. Auto Refresh (CBR)

Burst Length = 4,  $\overline{\text{CAS}}$  Latency = 2

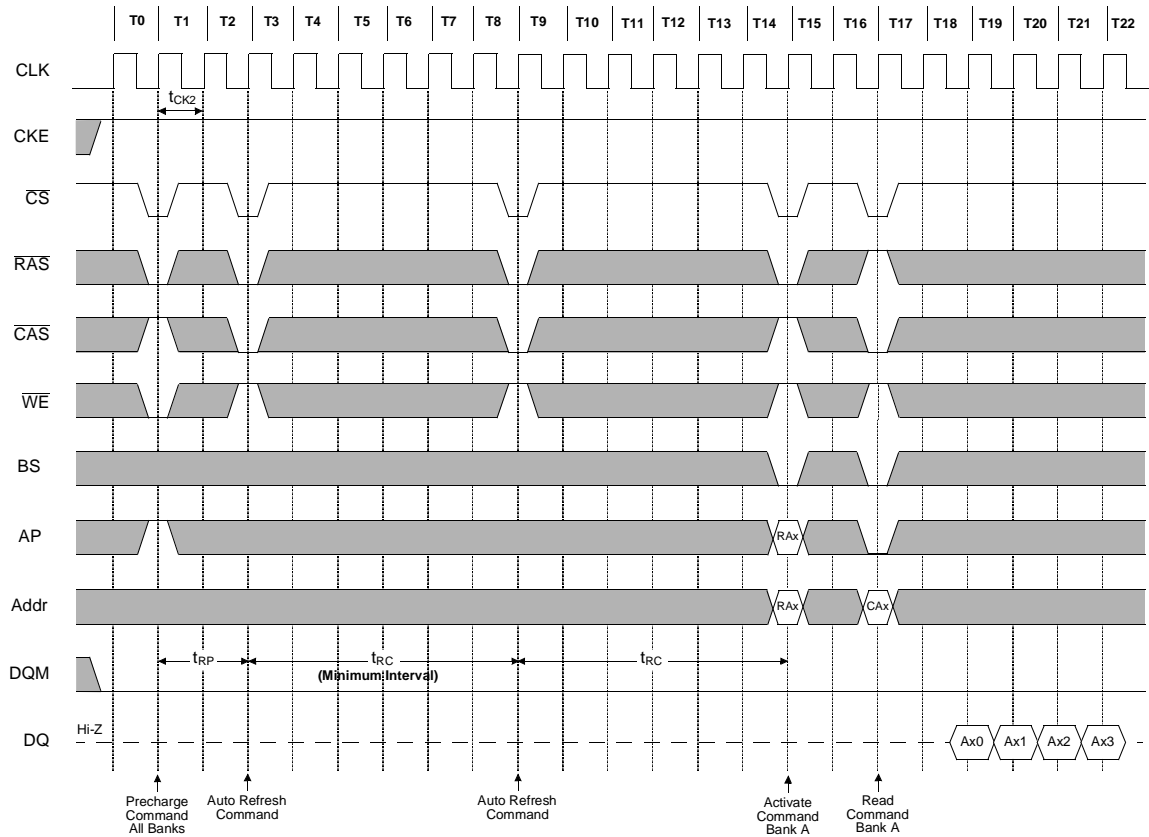

### 16.1 Random Column Read (Page within same Bank)

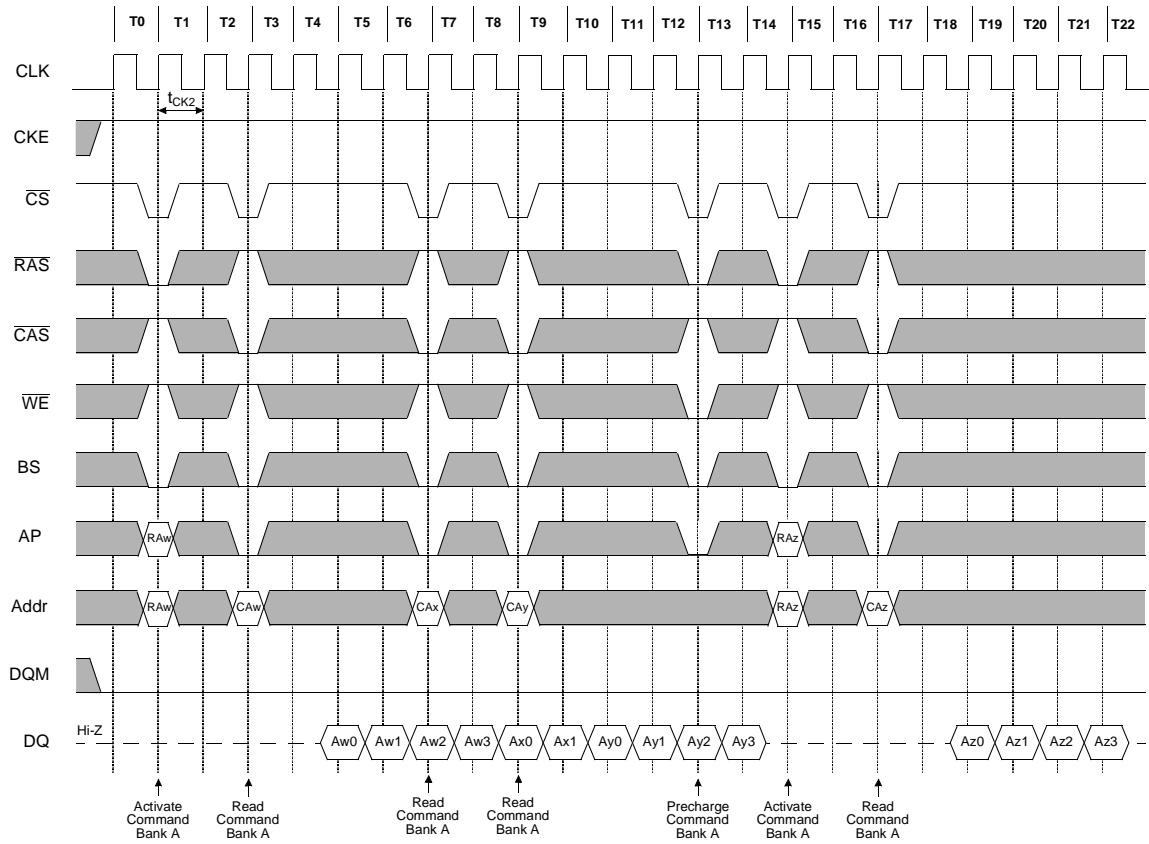
Burst Length = 4,  $\overline{\text{CAS}}$  Latency = 2



### 16.2 Random Column Read (Page within same Bank)

Burst Length = 4,  $\overline{\text{CAS}}$  Latency = 3

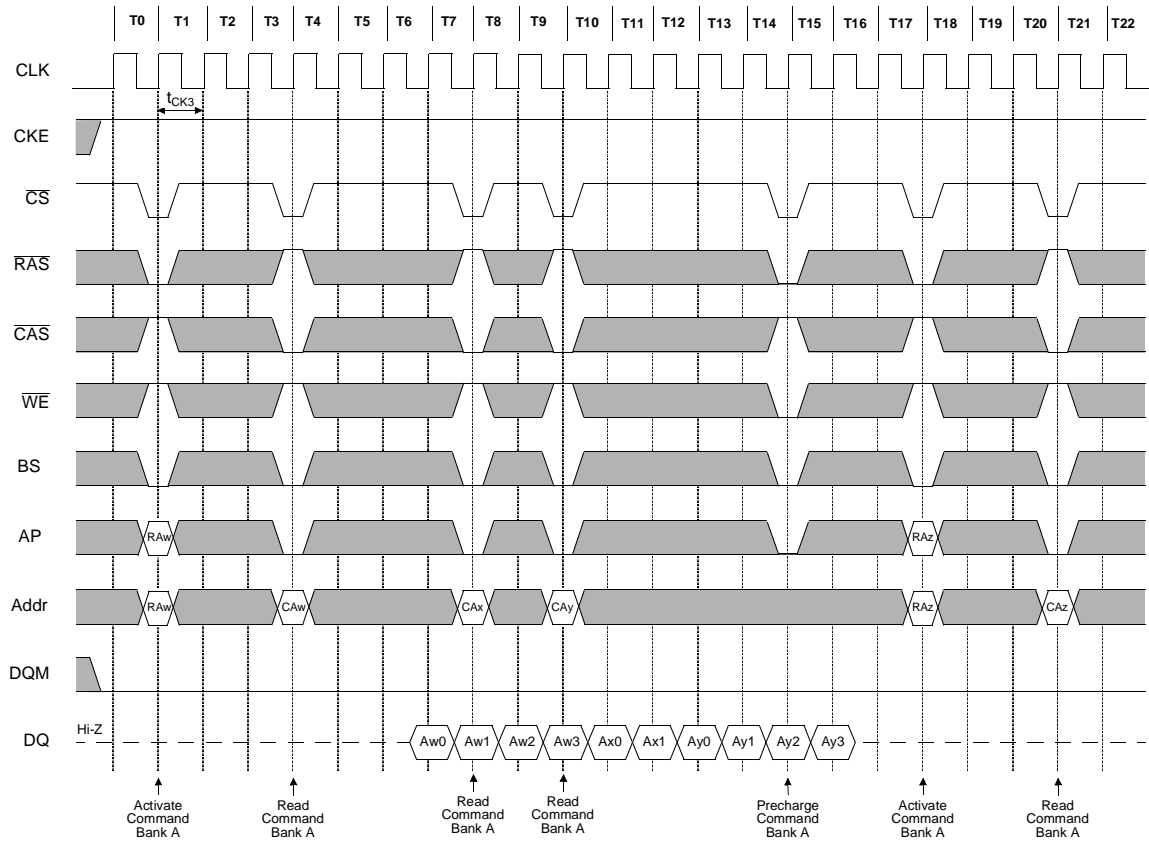

### 17.1 Random Column Write (Page within same Bank)

Burst Length = 4,  $\overline{\text{CAS}}$  Latency = 2

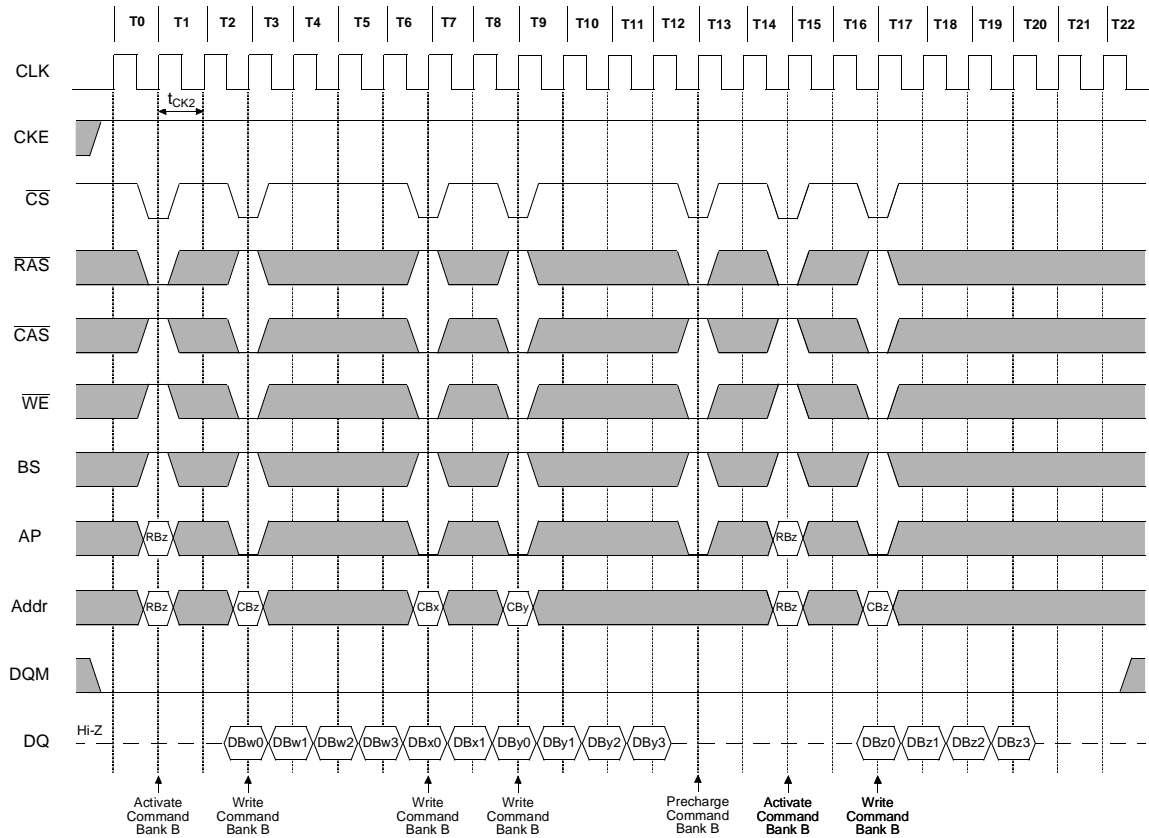

### 17.2 Random Column Write (Page within same Bank)

Burst Length = 4,  $\overline{\text{CAS}}$  Latency = 3

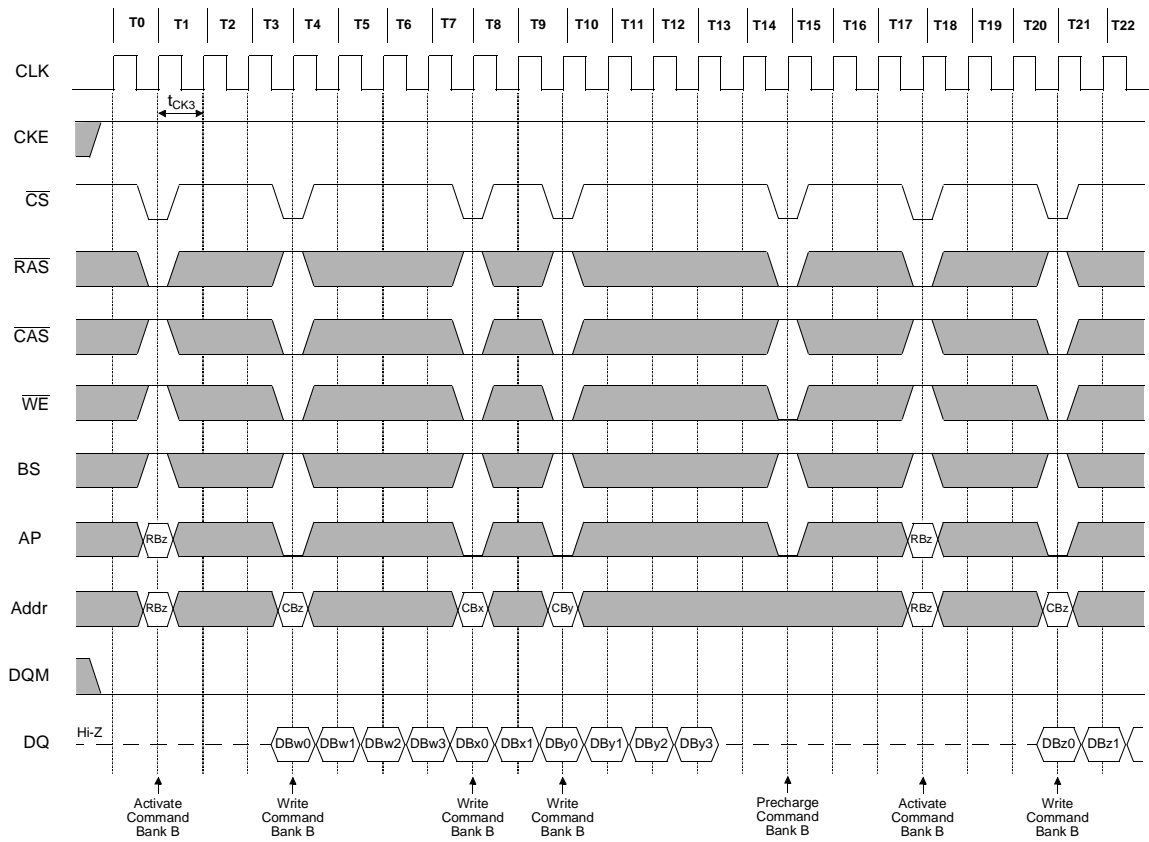

### 18.1 Random Row Read (Interleaving Banks) with Precharge

Burst Length = 8,  $\overline{\text{CAS}}$  Latency = 2

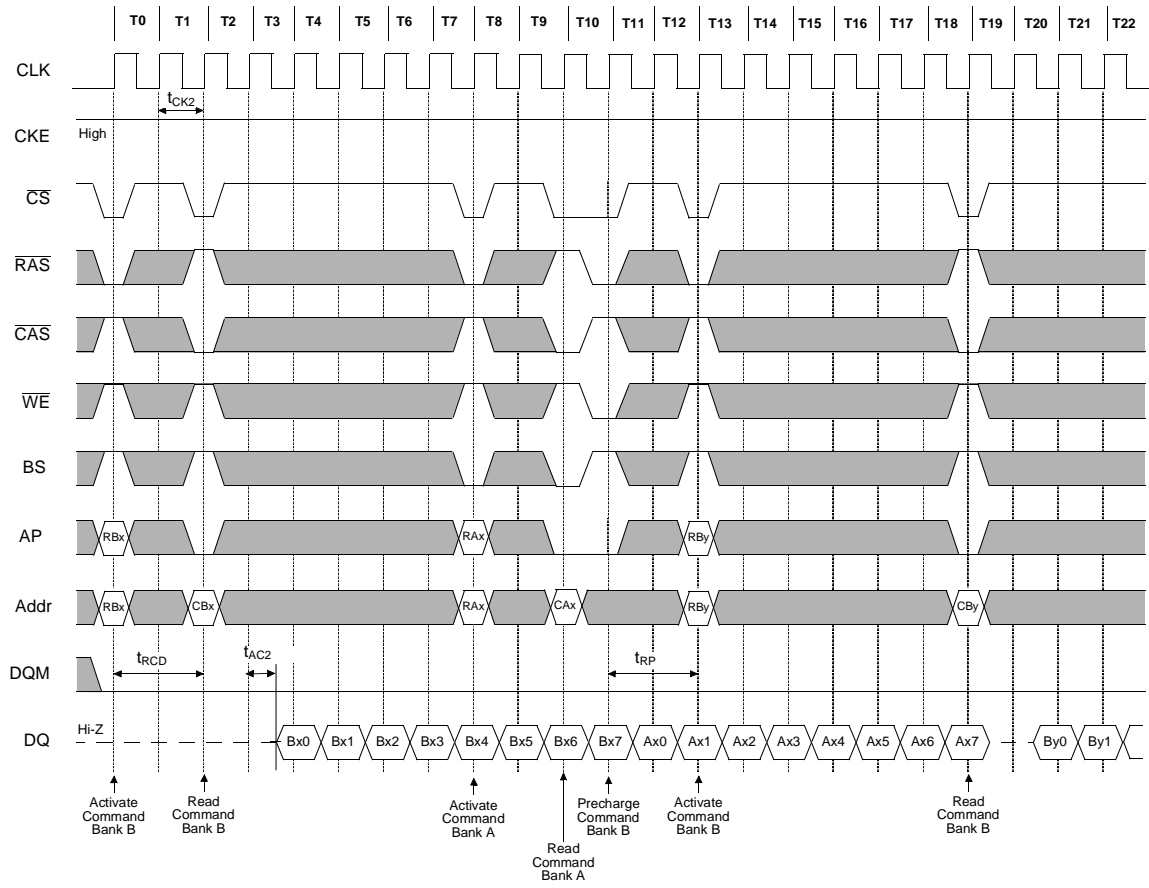

### 18.2 Random Row Read (Interleaving Banks) with Precharge

Burst Length = 8,  $\overline{\text{CAS}}$  Latency = 3

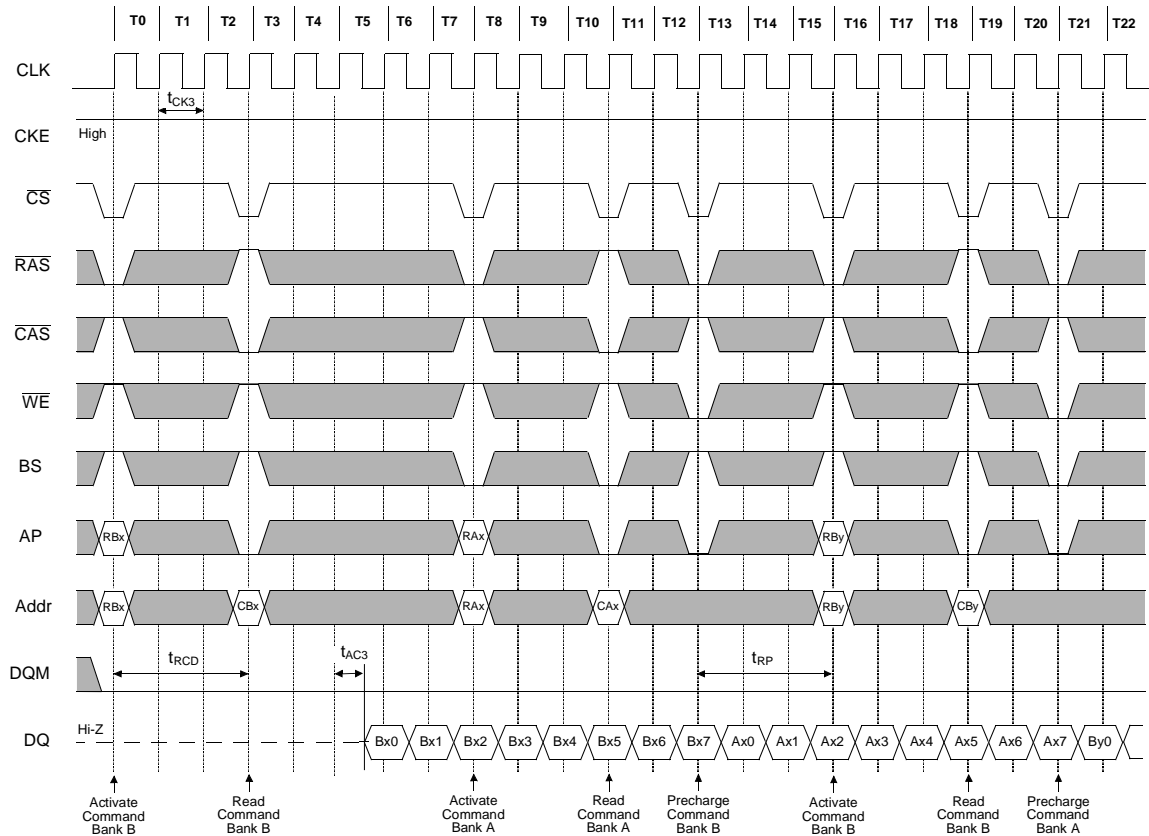

### 19.1 Random Row Write (Interleaving Banks) with Precharge

Burst Length = 8,  $\overline{\text{CAS}}$  Latency = 2

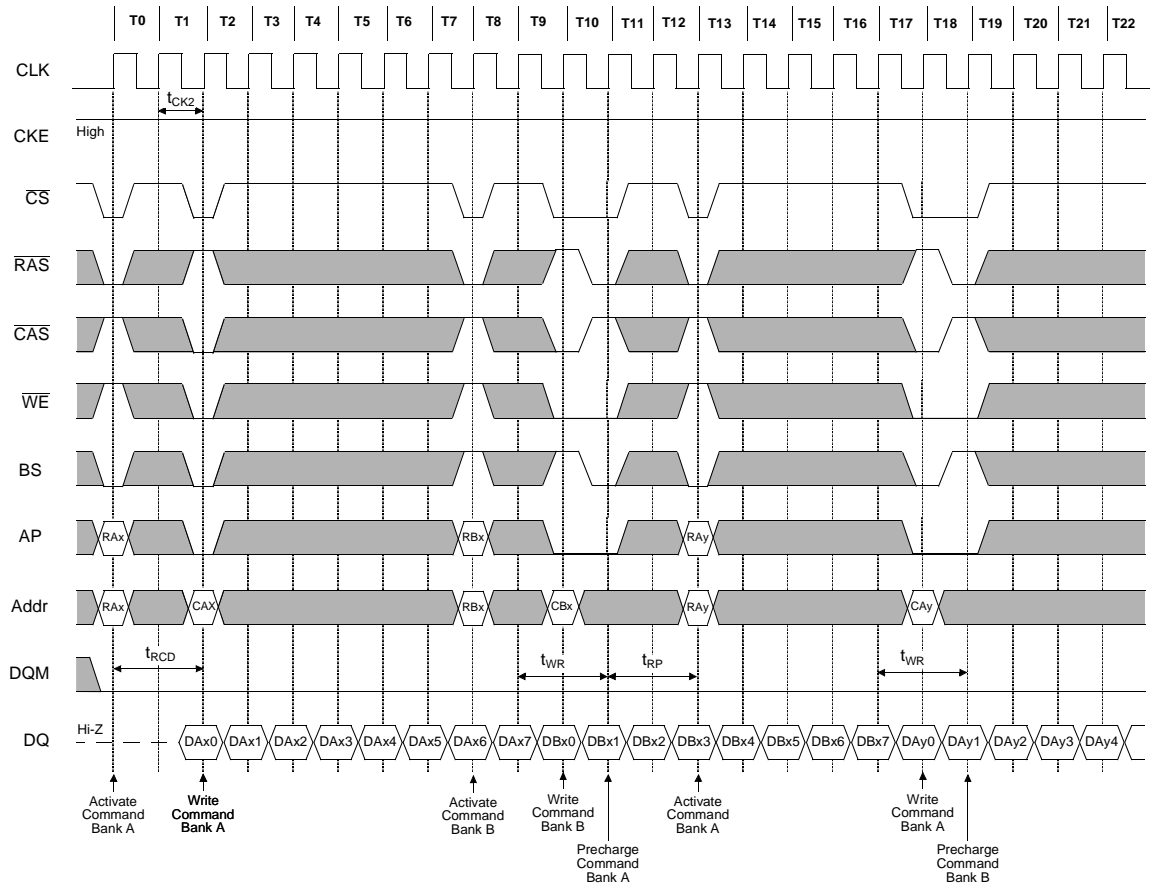

### 19.2 Random Row Write (Interleaving Banks) with Precharge

Burst Length = 8,  $\overline{\text{CAS}}$  Latency = 3

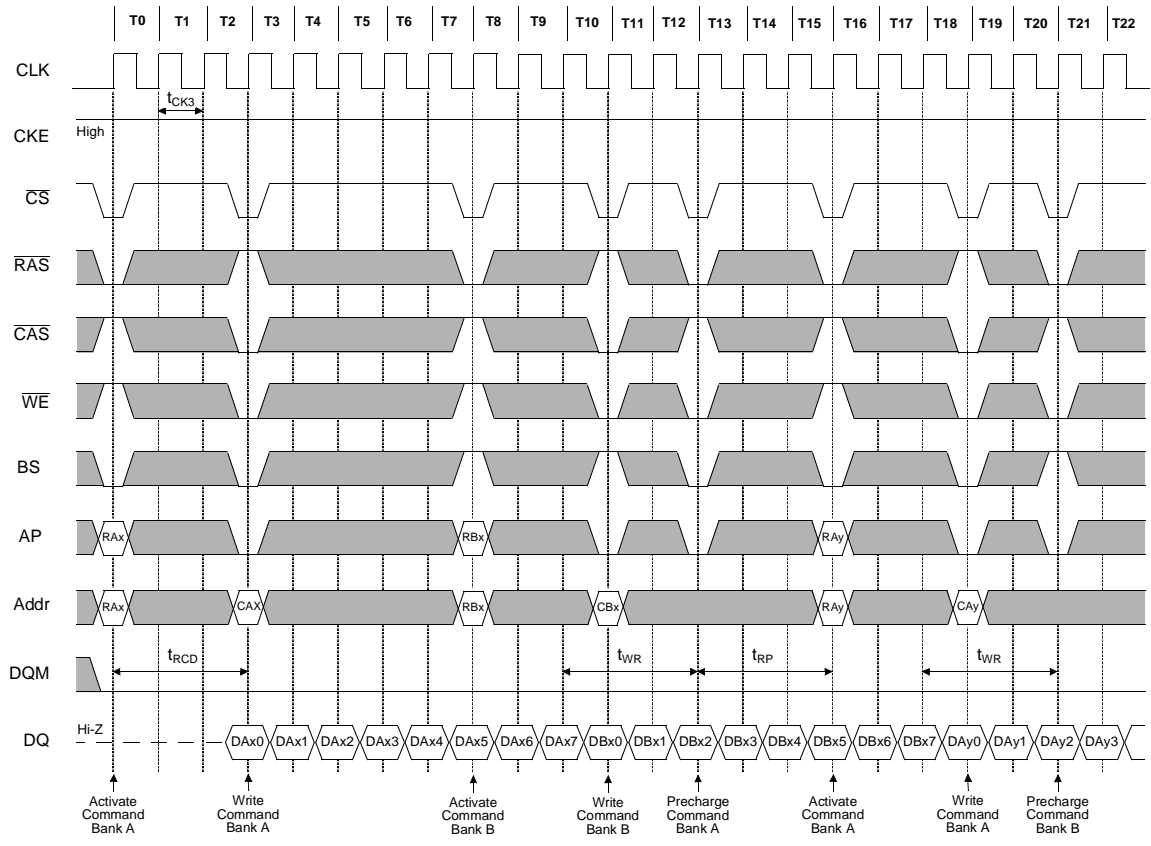

## 20.1 Full Page Read Cycle

Burst Length = Full Page,  $\overline{\text{CAS}}$  Latency = 2

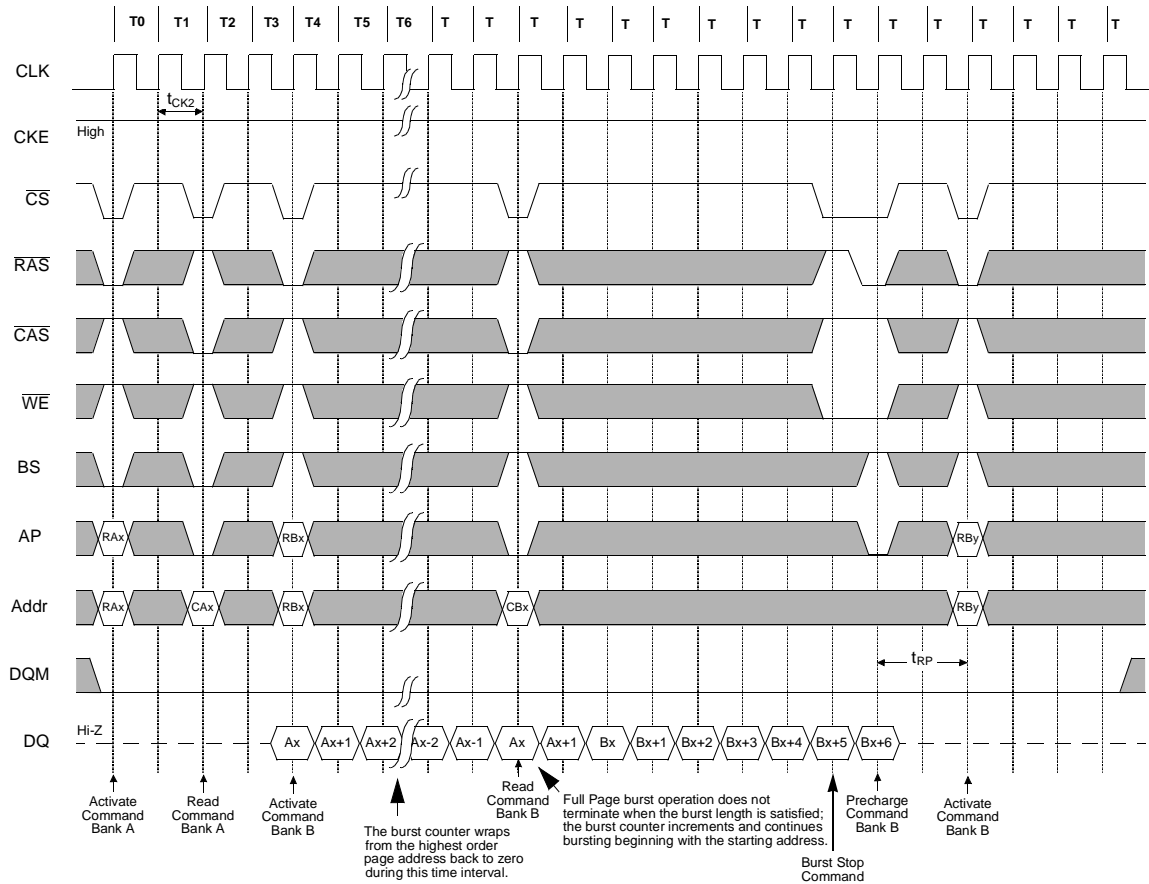





## 21.1 Full Page Write Cycle

Burst Length = Full Page,  $\overline{\text{CAS}}$  Latency = 2

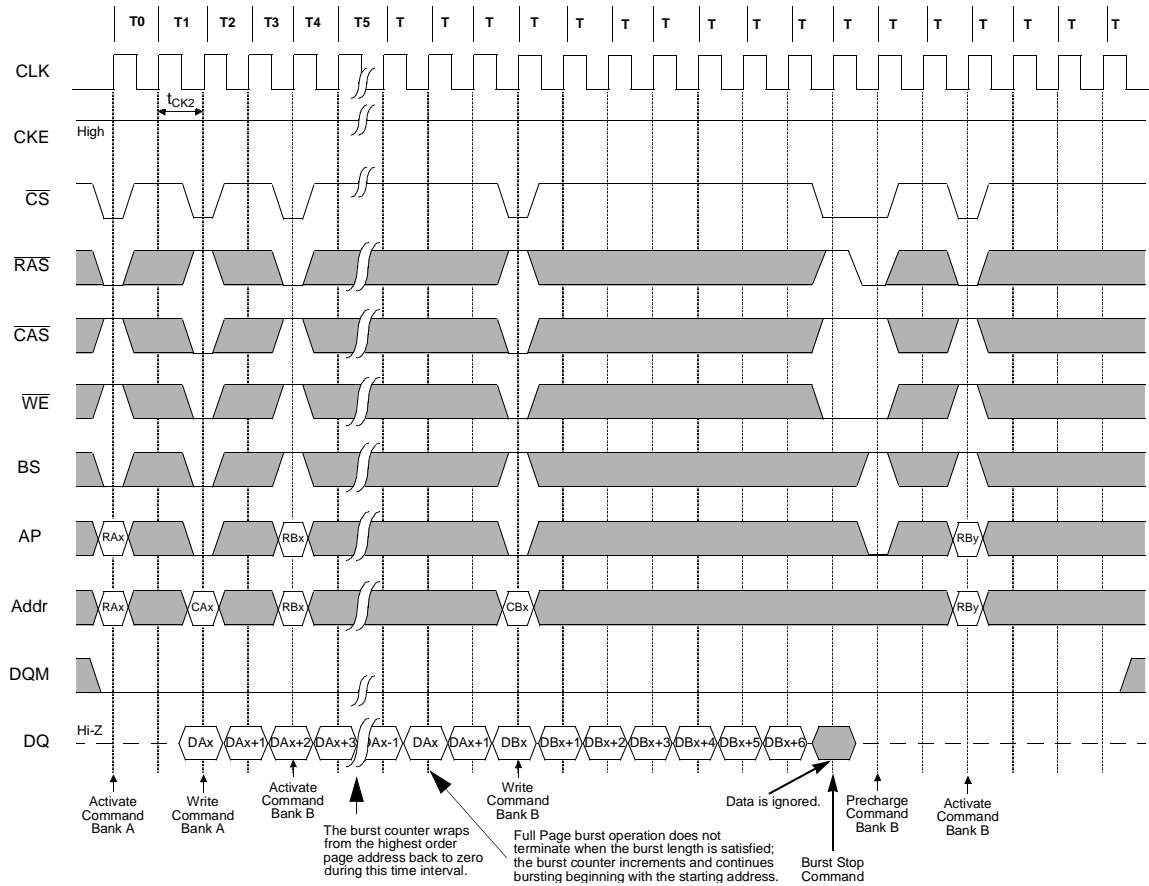

### 21.2 Full Page Write Cycle

Burst Length = Full Page,  $\overline{\text{CAS}}$  Latency = 3

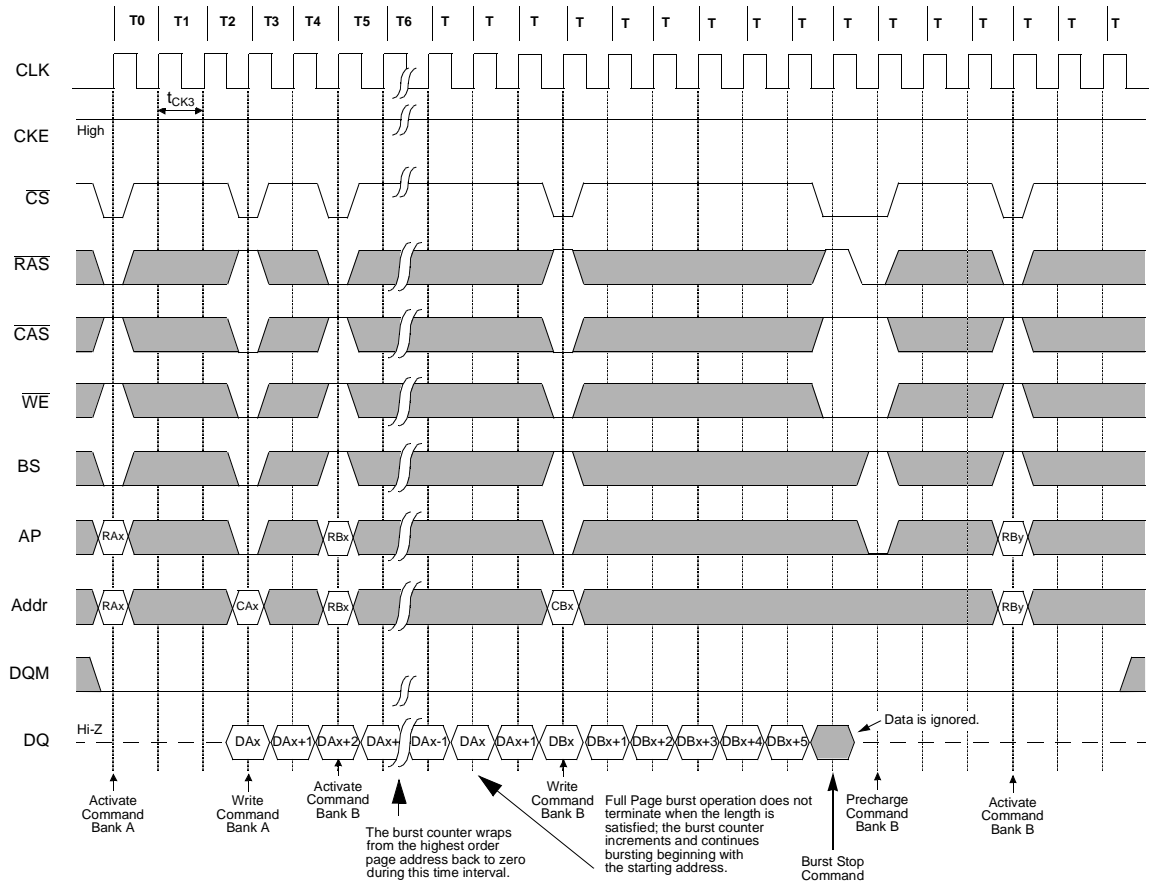

### 22.1 Precharge Termination of a Burst

Burst Length = 8 or Full Page, CAS Latency = 2

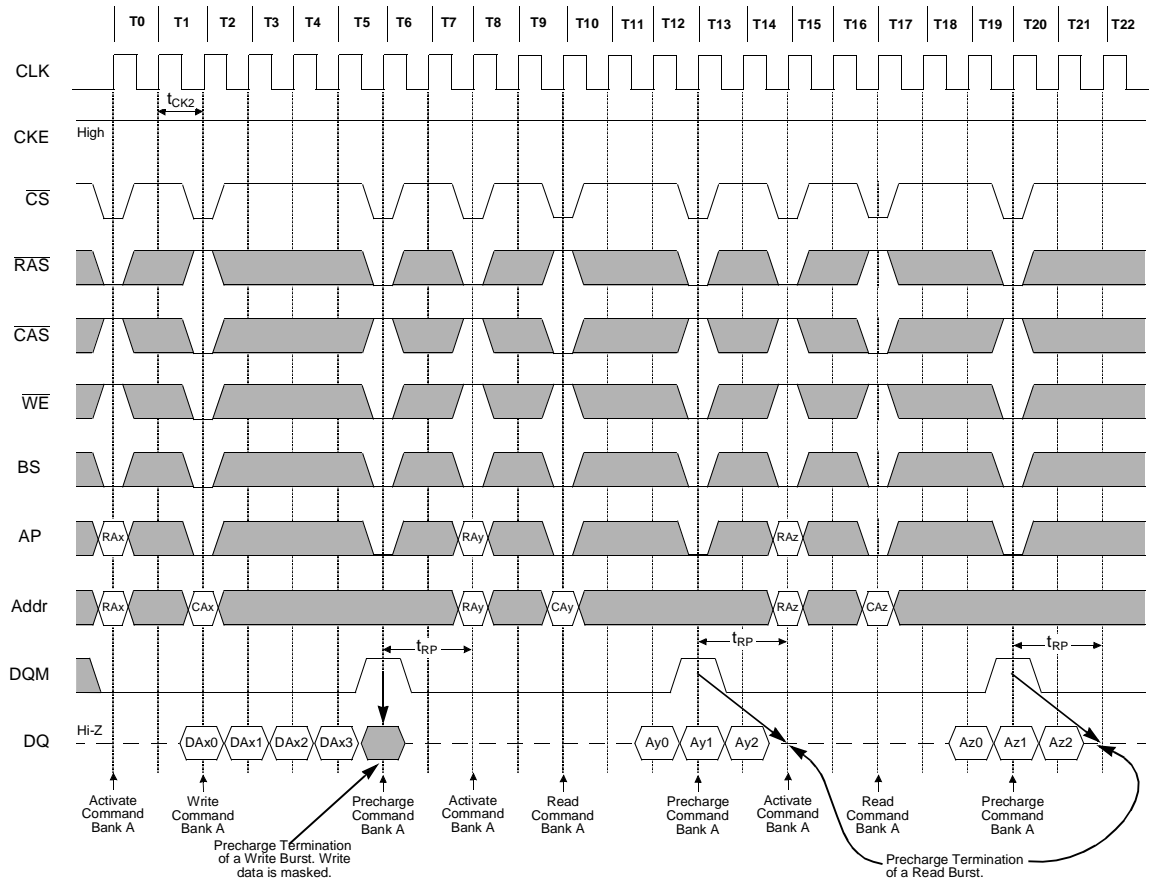

**Change List:**

Rev. 10.98	ICC6 for L-version changed from 400 $\mu$ A to 500 $\mu$ A