

SIEMENS

8M x 8-Bit Dynamic RAM (4k & 8k Refresh)

HYB 3164800J/T -50/-60
HYB 3165800J/T -50/-60

Preliminary Information

- 8 388 608 words by 8-bit organization
- 0 to 70 °C operating temperature
- Fast access and cycle time
 - $\overline{\text{RAS}}$ access time:
 - 50 ns (-50 version)
 - 60 ns (-60 version)
 - Cycle time:
 - 90 ns (-50 version)
 - 110 ns (-60 version)
 - $\overline{\text{CAS}}$ access time:
 - 13 ns (-50 version)
 - 15 ns (-60 version)
- Fast page mode cycle time
 - 35 ns (-50 version)
 - 40 ns (-60 version)
- Single + 3.3 V ($\pm 0.3\text{V}$) power supply
- Low power dissipation
 - max. 396 active mW (HYB 3164800J/T-50)
 - max. 360 active mW (HYB 3164800J/T-60)
 - max. 504 active mW (HYB 3165800J/T-50)
 - max. 432 active mW (HYB 3165800J/T-60)
 - 7.2 mW standby (TTL)
 - 720 W standby (MOS)
- Read, write, read-modify-write, $\overline{\text{CAS}}$ -before- $\overline{\text{RAS}}$ refresh (CBR), $\overline{\text{RAS}}$ -only refresh, hidden refresh and self refresh modes
- Fast page mode capability
- 8192 refresh cycles/128 ms , 13 R/ 10C addresses (HYB 3164800J/T)
- 4096 refresh cycles/ 64 ms , 12 R/ 11C addresses (HYB 3165800J/T)
- Plastic Package:

P-SOJ-34-1	500 mil	HYB 3164(5)800J
P-TSOPII-34-1	500 mil	HYB 3164(5)800T

This device is a 64 MBit dynamic RAM organized 8 388 608 by 8 bits. The device is fabricated in SIEMENS/IBM's most advanced first generation 64Mbit CMOS silicon gate process technology. The circuit and process design allow this device to achieve high performance and low power dissipation. This DRAM operates with a single 3.3 +/-0.3V power supply and interfaces with either LVTTTL or LVCMOS levels. Multiplexed address inputs permit the HYB 3164(5)800J/T to be packaged in a 500 mil wide SOJ-34 or TSOP-34 plastic package. These packages provide high system bit densities and are compatible with commonly used automatic testing and insertion equipment.

Ordering Information

Type	Ordering Code	Package		Descriptions
HYB 3164800J-50	on request	P-SOJ-34-1	500 mil	DRAM (access time 50 ns)
HYB 3164800J-60	on request	P-SOJ-34-1	500 mil	DRAM (access time 60 ns)
HYB 3164800T-50	on request	P-TSOPII-34-1	500 mil	DRAM (access time 50 ns)
HYB 3164800T-60	on request	P-TSOPII-34-1	500 mil	DRAM (access time 60 ns)
HYB 3165800J-50	on request	P-SOJ-34-1	500 mil	DRAM (access time 50 ns)
HYB 3165800J-60	on request	P-SOJ-34-1	500 mil	DRAM (access time 60 ns)
HYB 3165800T-50	on request	P-TSOPII-34-1	500 mil	DRAM (access time 50 ns)
HYB 3165800T-60	on request	P-TSOPII-34-1	500 mil	DRAM (access time 60 ns)

Pin Names

A0-A12	Address Inputs for HYB 3164800J/T
A0-A11	Address Inputs for HYB 3165800J/T
$\overline{\text{RAS}}$	Row Address Strobe
$\overline{\text{OE}}$	Output Enable
I/O1-I/O8	Data Input/Output
$\overline{\text{CAS}}$	Column Address Strobe
$\overline{\text{WRITE}}$	Read/Write Input
Vcc	Power Supply (+ 3.3V)
Vss	Ground

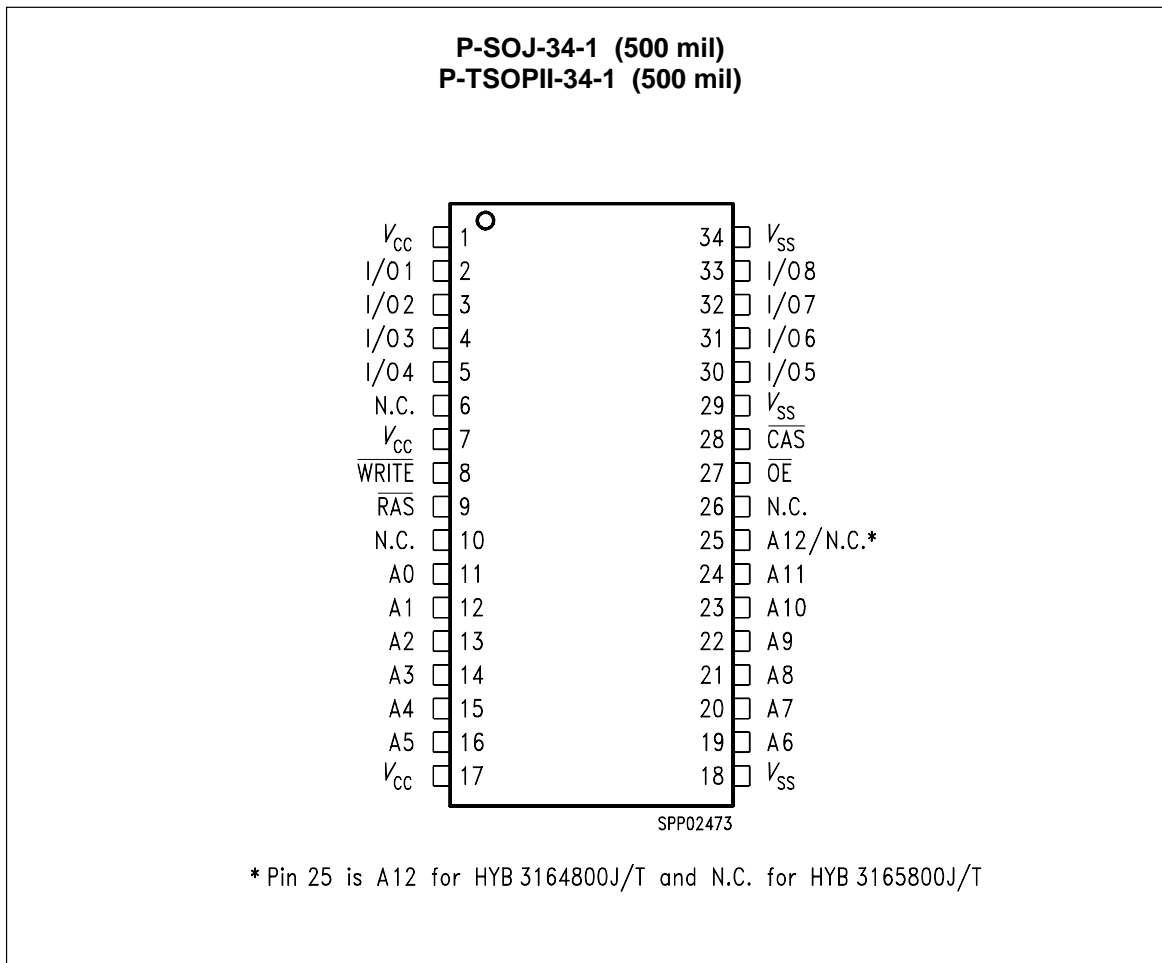

Pin Configuration

TRUTH TABLE

FUNCTION		$\overline{\text{RAS}}$	$\overline{\text{CAS}}$	$\overline{\text{WRITE}}$	$\overline{\text{OE}}$	ROW ADDR	COL ADDR	I/O1-I/O8
Standby		H	H - X	X	X	X	X	High Impedance
Read		L	L	H	L	ROW	COL	Data Out
Early-Write		L	L	L	X	ROW	COL	Data In
Delayed-Write		L	L	H - L	H	ROW	COL	Data In
Read-Modify-Write		L	L	H - L	L - H	ROW	COL	Data Out, Data In
Fast Page Mode Read	1st Cycle	L	H - L	H	L	ROW	COL	Data Out
	2nd Cycle	L	H - L	H	L	n/a	COL	Data Out
Fast Page Mode Early Write	1st Cycle	L	H - L	L	X	ROW	COL	Data In
	2nd Cycle	L	H - L	L	X	n/a	COL	Data In
Fast Page Mode RMW	1st Cycle	L	H - L	H - L	L - H	ROW	COL	Data Out, Data In
	2st Cycle	L	H - L	H - L	L - H	n/a	COL	Data Out, Data In
RAS only refresh		L	H	X	X	ROW	n/a	High Impedance
CAS-before-RAS refresh		H - L	L	H	X	X	n/a	High Impedance
Test Mode Entry		H - L	L	L	X	X	n/a	High Impedance
Hidden Refresh	READ	L-H-L	L	H	L	ROW	COL	Data Out
	WRITE	L-H-L	L	L	X	ROW	COL	Data In

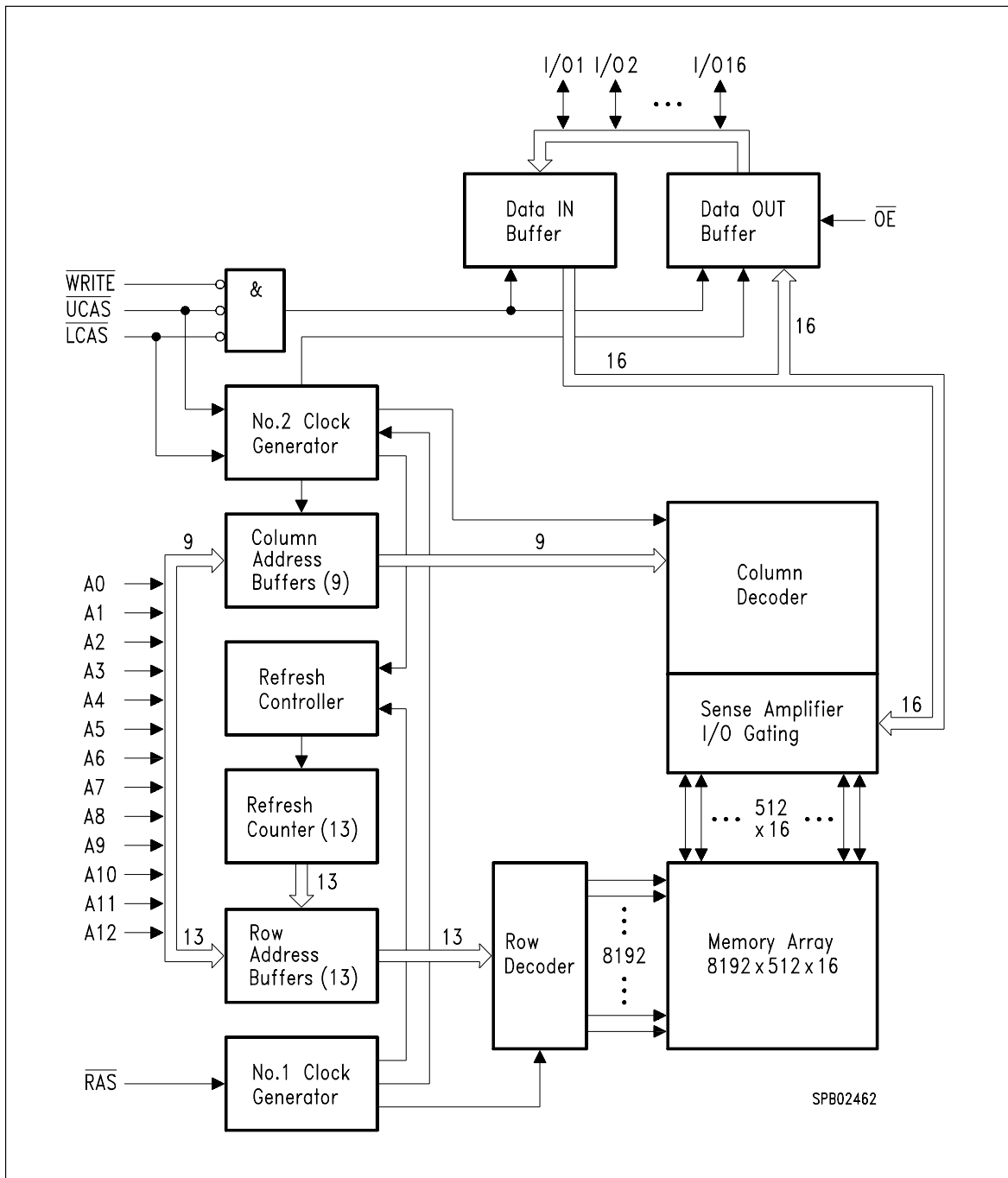

Block Diagram for HYB 3165800J/T

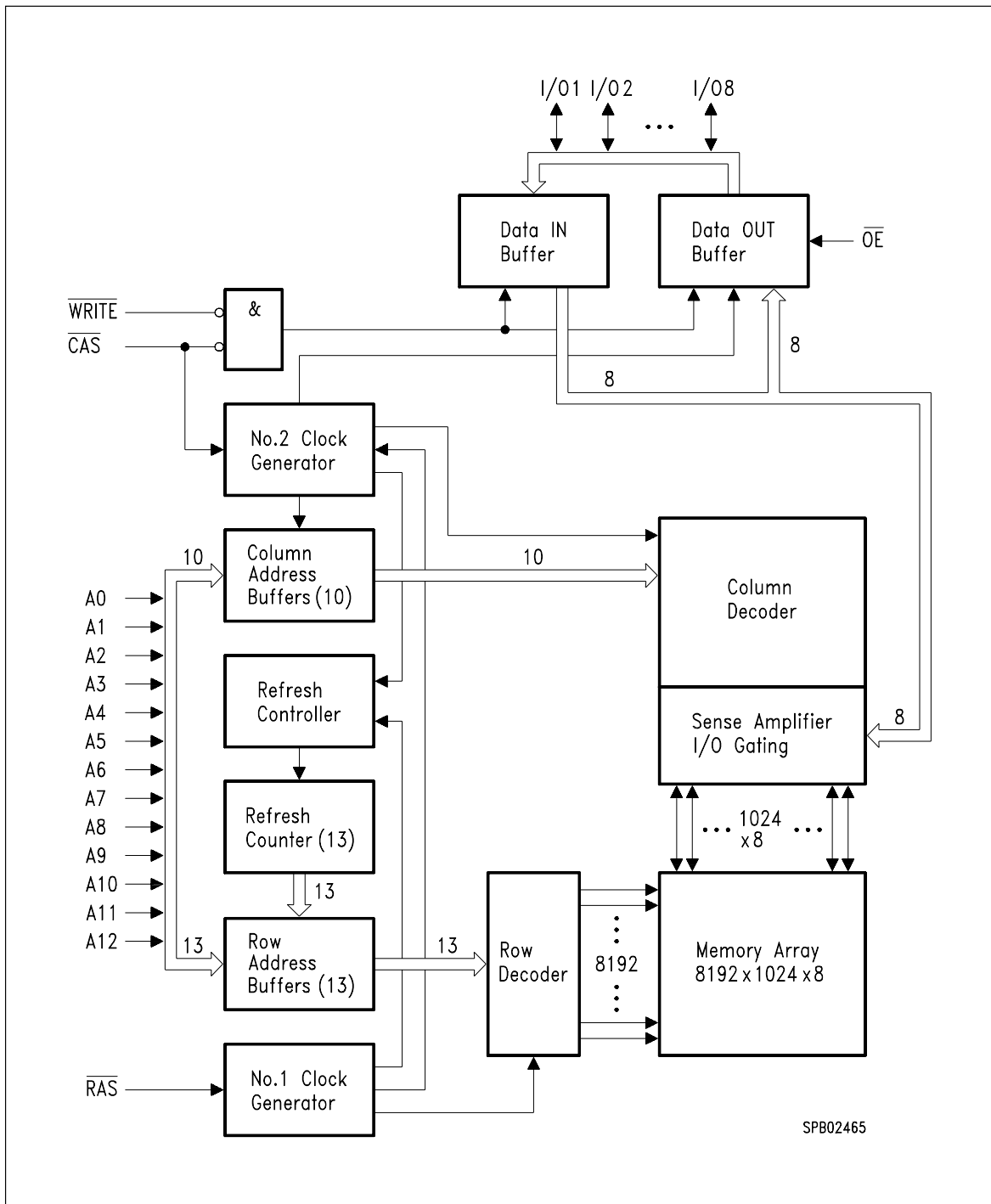

Block Diagram for HYB 3164800J/T

Absolute Maximum Ratings

Operating temperature range.....	0 to 70 °C
Storage temperature range.....	- 55 to 150 °C
Input/output voltage.....	-0.5 to min (V _{CC} +0.5,4.6) V
Power supply voltage.....	-0.5V to 4.6 V
Power dissipation.....	1.0 W
Data out current (short circuit).....	50 mA

Note

Stresses above those listed under „Absolute Maximum Ratings“ may cause permanent damage of the device. Exposure to absolute maximum rating conditions for extended periods may effect device reliability.

DC Characteristics

T_A = 0 to 70 °C, V_{SS} = 0 V, V_{CC} = 3.3 V ± 0.3 V, (values in brackets for HYB 3165800J/T)

Parameter	Symbol	Limit Values		Unit	Note
		min.	max.		
Input high voltage	V _{IH}	2.0	V _{CC} +0.3	V	1)
Input low voltage	V _{IL}	- 0.3	0.8	V	1)
Output high voltage (LVTTTL) Output „H“ level voltage (I _{out} = -2mA)	V _{OH}	2.4	-	V	
Output low voltage (LVTTTL) Output „L“ level voltage (I _{out} = +2mA)	V _{OL}	-	0.4	V	
Output high voltage (LVCMOS) Output „H“ level voltage (I _{out} = -100uA)	V _{OH}	V _{CC} -0.2	-	V	
Output low voltage (LVCMOS) Output „L“ level voltage (I _{out} = +100uA)	V _{OL}	-	0.2	V	
Input leakage current,any input (0 V < V _{in} < V _{CC} , all other pins = 0 V)	I _{I(L)}	- 2	2	μA	
Output leakage current (DO is disabled, 0 V < V _{out} < V _{CC})	I _{O(L)}	- 2	2	μA	
Average V _{CC} supply current: -50 ns version -60 ns version ($\overline{\text{RAS}}$, $\overline{\text{CAS}}$, address cycling: t _{RC} = t _{RC} min.)	I _{CC1}	-	110 (140) 100 (120)	mA mA	2) 3) 4)
Standby V _{CC} supply current (RAS=CAS= V _{Ih})	I _{CC2}	-	2	mA	-

DC Characteristics *(cont'd)*

$T_A = 0$ to 70 °C, $V_{SS} = 0$ V, $V_{CC} = 3.3$ V \pm 0.3 V, (values in brackets for HYB 3165800J/T)

Parameter	Symbol	Limit Values		Unit	Note
		min.	max.		
Average Vcc supply current, during RAS-only refresh cycles: -50 ns version -60 ns version (RAS cycling: CAS = VIH: tRC = tRC min.)	I_{CC3}	–	110 (140) 100 (120)	mA mA	2) 4)
Average Vcc supply current, during fast page mode: -50 ns version -60 ns version ($\overline{RAS} = V_{IL}$, \overline{CAS} , address cycling: tPC=tPC min.)	I_{CC4}	–	85 (85) 75 (75)	mA mA	2) 3) 4)
Standby Vcc supply current ($\overline{RAS}=\overline{CAS}= V_{CC}-0.2V$)	I_{CC5}	–	200	A	–
Average Vcc supply current, during \overline{CAS} -before- \overline{RAS} refresh mode: -50 ns version -60 ns version (\overline{RAS} , \overline{CAS} cycling: tRC = tRC min.)	I_{CC6}	–	110 (140) 100 (120)	mA mA	2) 4)
Self Refresh Current Average Power Supply Current during Self Refresh. (CBR cycle with tRAS>TRASSmin, \overline{CAS} held low, WE = Vcc-0.2V, Address and Din=Vcc-0.2V or 0.2V)	I_{CC7}	–	400	A	

Capacitance

$T_A = 0$ to 70 °C, $V_{CC} = 3.3$ V \pm 0.3 V, $f = 1$ MHz

Parameter	Symbol	Limit Values		Unit
		min.	max.	
Input capacitance (A0 to A11,A12)	C_{I1}	–	5	pF
Input capacitance (\overline{RAS} , \overline{CAS} , WRITE, OE)	C_{I2}	–	7	pF
I/O capacitance (I/O1-I/O8)	C_{I0}	–	7	pF

AC Characteristics (note: 6,7,8)

$T_A = 0$ to 70 °C, $V_{CC} = 3.3 \pm 0.3V$

Parameter	Symbol	HYB 3164(5)800 J/T-50		HYB 3164(5)800 J/T-60		Unit	Note
		min.	max.	min.	max.		
common parameters							
Random read or write cycle time	t_{RC}	90	–	110	–	ns	
\overline{RAS} precharge time	t_{RP}	30	–	40	–	ns	
\overline{RAS} pulse width	t_{RAS}	50	100k	60	100k	ns	
\overline{CAS} pulse width	t_{CAS}	13	100k	15	100k	ns	
Row address setup time	t_{ASR}	0	–	0	–	ns	
Row address hold time	t_{RAH}	8	–	10	–	ns	
Column address setup time	t_{ASC}	0	–	0	–	ns	
Column address hold time	t_{CAH}	10	–	10	–	ns	
\overline{RAS} to \overline{CAS} delay time	t_{RCD}	18	37	20	45		
\overline{RAS} to column address delay time	t_{RAD}	13	25	15	30	ns	
\overline{RAS} hold time	t_{RSH}	13	–	15	–	ns	
\overline{CAS} hold time	t_{CSH}	50	–	60	–	ns	
\overline{CAS} to \overline{RAS} precharge time	t_{CRP}	5	–	5	–	ns	
Transition time (rise and fall)	t_T	3	30	3	30	ns	7
Refresh period for HYB3164800	t_{REF}	–	128	–	128	ms	
Refresh period for HYB3165800	t_{REF}	–	64	–	64	ms	

Read Cycle

Access time from \overline{RAS}	t_{RAC}	–	50	–	60	ns	8, 9
Access time from \overline{CAS}	t_{CAC}	–	13	–	15	ns	8, 9
Access time from column address	t_{AA}	–	25	–	30	ns	8, 10
\overline{OE} access time	t_{OEA}	–	13	–	15	ns	8
Column address to \overline{RAS} lead time	t_{RAL}	25	–	30	–	ns	
Read command setup time	t_{RCS}	0	–	0	–	ns	
Read command hold time	t_{RCH}	0	–	0	–	ns	11
Read command hold time referenced to \overline{RAS}	t_{RRH}	0	–	0	–	ns	11

AC Characteristics (cont'd)(note: 6,7,8)

$T_A = 0$ to 70 °C, $V_{CC} = 3.3 \pm 0.3V$

Parameter	Symbol	HYB 3164(5)800 J/T-50		HYB 3164(5)800 J/T-60		Unit	Note
		min.	max.	min.	max.		
$\overline{\text{CAS}}$ to output in low-Z	t_{CLZ}	0	–	0	–	ns	8
Output buffer turn-off delay	t_{OFF}	–	13	–	15	ns	12
Output buffer turn-off delay from $\overline{\text{OE}}$	t_{OEZ}	–	13	–	15	ns	12
Data to $\overline{\text{OE}}$ low delay	t_{DZO}	0	–	0	–	ns	13
$\overline{\text{CAS}}$ high to data delay	t_{CDD}	13	–	15	–	ns	14
$\overline{\text{OE}}$ high to data delay	t_{ODD}	13	–	15	–	ns	14

Write Cycle

Write command hold time	t_{WCH}	8	–	10	–	ns	
Write command pulse width	t_{WP}	8	–	10	–	ns	
Write command setup time	t_{WCS}	0	–	0	–	ns	15
Write command to $\overline{\text{RAS}}$ lead time	t_{RWL}	13	–	15	–	ns	
Write command to $\overline{\text{CAS}}$ lead time	t_{CWL}	13	–	15	–	ns	
Data setup time	t_{DS}	0	–	0	–	ns	16
Data hold time	t_{DH}	10	–	10	–	ns	16
$\overline{\text{CAS}}$ delay time from Din	t_{DZC}	0	–	0	–	ns	13

Read-Modify-Write Cycle

Read-write cycle time	t_{RWC}	126	–	150	–	ns	
$\overline{\text{RAS}}$ to $\overline{\text{WE}}$ delay time	t_{RWD}	68	–	80	–	ns	15
$\overline{\text{CAS}}$ to $\overline{\text{WE}}$ delay time	t_{CWD}	31	–	35	–	ns	15
Column address to $\overline{\text{WE}}$ delay time	t_{AWD}	43	–	50	–	ns	15
$\overline{\text{OE}}$ command hold time	t_{OEH}	13	–	15	–	ns	

Fast Page Mode Cycle

Fast page mode cycle time	t_{PC}	35	–	40	–	ns	
$\overline{\text{CAS}}$ precharge time	t_{CP}	10	–	10	–	ns	
Access time from $\overline{\text{CAS}}$ precharge	t_{CPA}	–	30	–	35	ns	8
$\overline{\text{RAS}}$ pulse width	t_{RAS}	50	200k	60	200k	ns	

AC Characteristics (cont'd)(note: 6,7,8)

$T_A = 0$ to 70 °C, $V_{CC} = 3.3 \pm 0.3V$

Parameter	Symbol	HYB 3164(5)800 J/T-50		HYB 3164(5)800 J/T-60		Unit	Note
		min.	max.	min.	max.		
\overline{CAS} precharge to \overline{RAS} Delay	t_{RHCP}	30	–	35	–	ns	

Fast Page Mode Read-Modify-Write Cycle

Fast page mode read-write cycle time	t_{PRWC}	71	–	80	–	ns	
\overline{CAS} precharge to \overline{WE}	t_{CPWD}	48	–	55	–	ns	

\overline{CAS} -before- \overline{RAS} refresh cycle

\overline{CAS} setup time	t_{CSR}	5	–	5	–	ns	
\overline{CAS} hold time	t_{CHR}	10	–	10	–	ns	
\overline{RAS} to \overline{CAS} precharge time	t_{RPC}	5	–	5	–	ns	
Write to \overline{RAS} precharge time	t_{WRP}	10	–	10	–	ns	
Write hold time referenced to \overline{RAS}	t_{WRH}	10	–	10	–	ns	

\overline{CAS} -before- \overline{RAS} counter test cycle

\overline{CAS} precharge time	t_{CPT}	25	–	30	–	ns	
---------------------------------	-----------	----	---	----	---	----	--

Test mode cycle

Write command setup time	t_{WTS}	10	–	10	–	ns	
Write command hold time	t_{WTH}	10	–	10	–	ns	

Self Refresh Cycle

\overline{RAS} pulse width	t_{RASS}	100k	–	100k	–	ns	17
\overline{RAS} precharge time	t_{RPS}	90	–	110	–		17
\overline{CAS} hold time	t_{CHS}	-50	–	-50	–	ns	17

Notes:

- 1) All voltages are referenced to VSS.
- 2) ICC1, ICC3, ICC4 and ICC6 and ICC7 depend on cycle rate.
- 3) ICC1 and ICC4 depend on output loading. Specified values are measured with the output open.
- 4) Address can be changed once or less while $\overline{RAS} = V_{il}$. In the case of ICC4 it can be changed once or less during a fast page mode cycle (tpc).
- 5) An initial pause of 100 ns is required after power-up followed by 8 \overline{RAS} -only-refresh cycles, before proper device operation is achieved. In case of using internal refresh counter, a minimum of 8 \overline{CAS} -before- \overline{RAS} initialization cycles instead of 8 \overline{RAS} cycles are required.
- 6) AC measurements assume $t_T = 5$ ns.
- 7) V_{IH} (min.) and V_{IL} (max.) are reference levels for measuring timing of input signals. Also, transition times are measured between V_{IH} and V_{IL} .
- 8) Measured with the specified current load and 100 pF at $V_{oh} = 2.0$ V and $V_{ol} = 0.8$ V.
- 9) Operation within the t_{RCD} (max.) limit ensures that t_{RAC} (max.) can be met. t_{RCD} (max.) is specified as a reference point only: If t_{RCD} is greater than the specified t_{RCD} (max.) limit, then access time is controlled by t_{CAC} .
- 10) Operation within the t_{RAD} (max.) limit ensures that t_{RAC} (max.) can be met. t_{RAD} (max.) is specified as a reference point only: If t_{RAD} is greater than the specified t_{RAD} (max.) limit, then access time is controlled by t_{AA} .
- 11) Either t_{RCH} or t_{RRH} must be satisfied for a read cycle.
- 12) t_{OFF} (max.) and t_{OEZ} (max.) define the time at which the outputs achieve the open-circuit condition and are not referenced to output voltage levels.
- 13) Either t_{DZC} or t_{DZO} must be satisfied.
- 14) Either t_{CDD} or t_{ODD} must be satisfied.
- 15) t_{WCS} , t_{RWD} , t_{CWD} , t_{AWD} and t_{CPWD} are not restrictive operating parameters. They are included in the data sheet as electrical characteristics only. If $t_{WCS} > t_{WCS}(\text{min.})$, the cycle is an early write cycle and the I/O pin will remain open-circuit (high impedance) through the entire cycle; if $t_{RWD} > t_{RWD}(\text{min.})$, $t_{CWD} > t_{CWD}(\text{min.})$, $t_{AWD} > t_{AWD}(\text{min.})$ and $t_{CPWD} > t_{CPWD}(\text{min.})$, the cycle is a read-write cycle and I/O pins will contain data read from the selected cells. If neither of the above sets of conditions is satisfied, the condition of the I/O pins (at access time) is indeterminate.
- 16) These parameters are referenced to \overline{CAS} leading edge in early write cycles and to \overline{WRITE} leading edge in Read-Modify-Write cycles.
- 17) When using Self Refresh mode, the following refresh operations must be performed to ensure proper DRAM operation:
If row addresses are being refresh in an evenly distributed manner over the refresh interval using CBR refresh cycles, then only one CBR cycle must be performed immediately after exit from Self Refresh.
If row addresses are being refresh in any other manner (ROR - Distributed/Burst or CBR-Burst) over the refresh interval, then a full set of row refreshed must be performed immediately before entry to and immediately after exit from Self Refresh

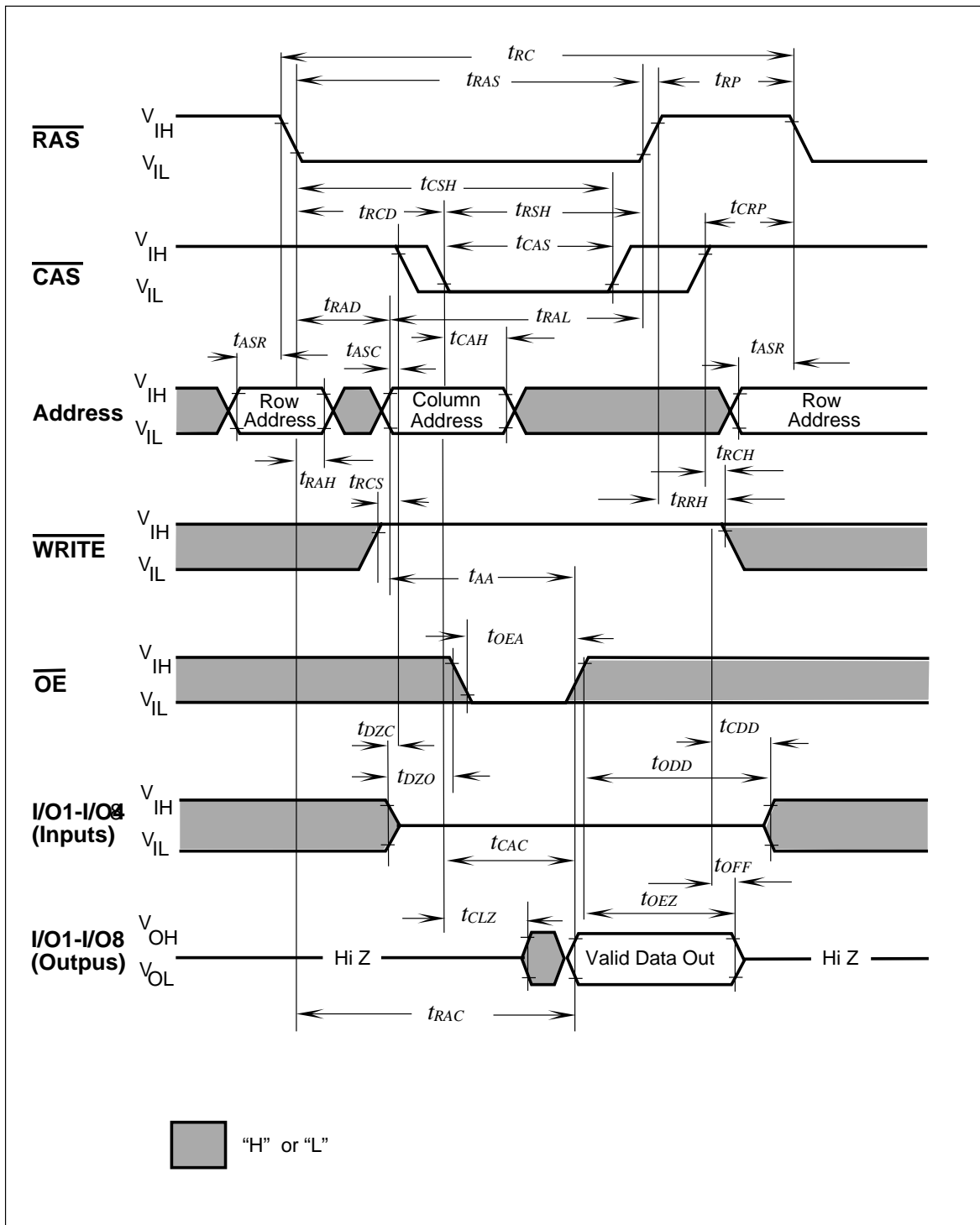

Read Cycle

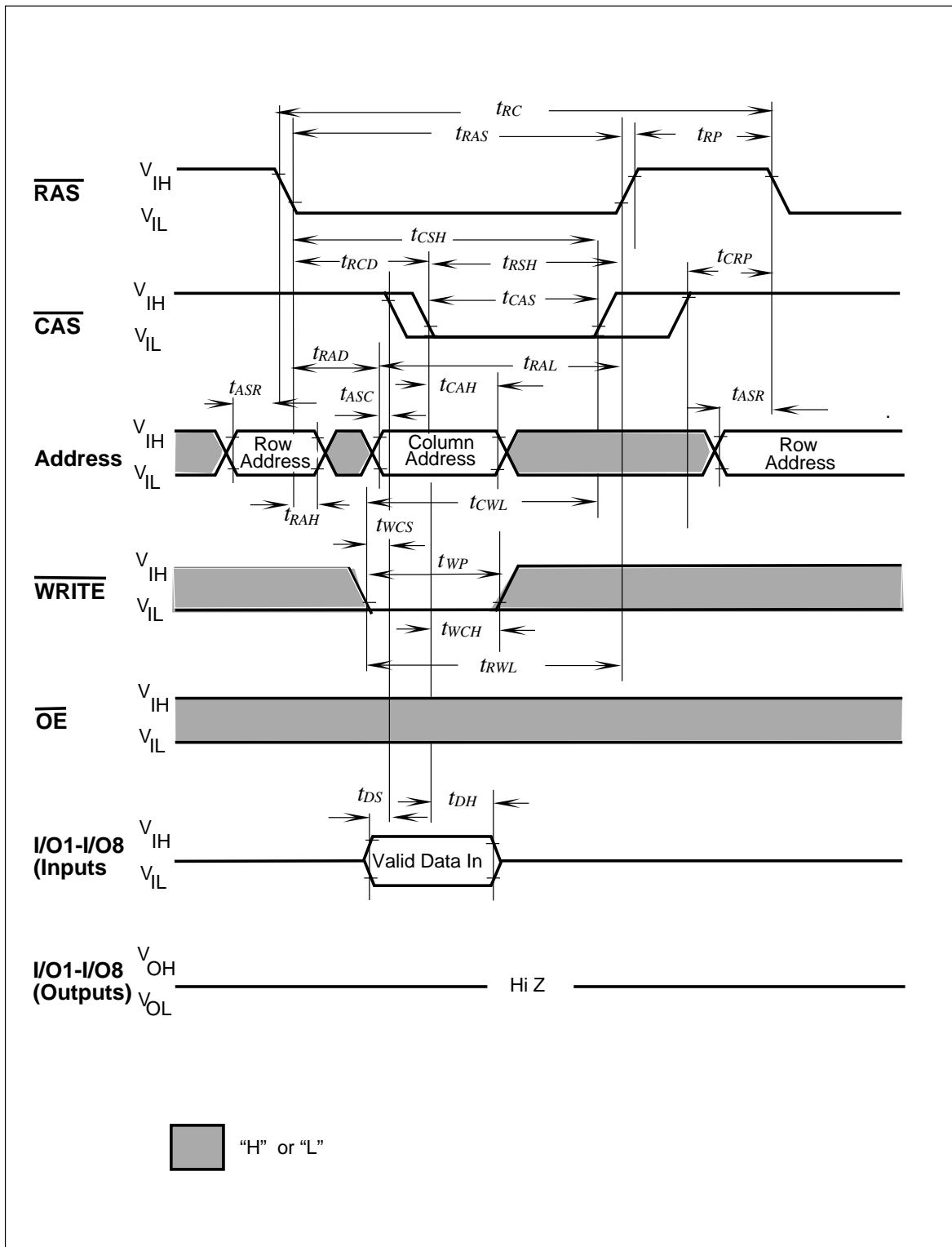

Write Cycle (Early Write)

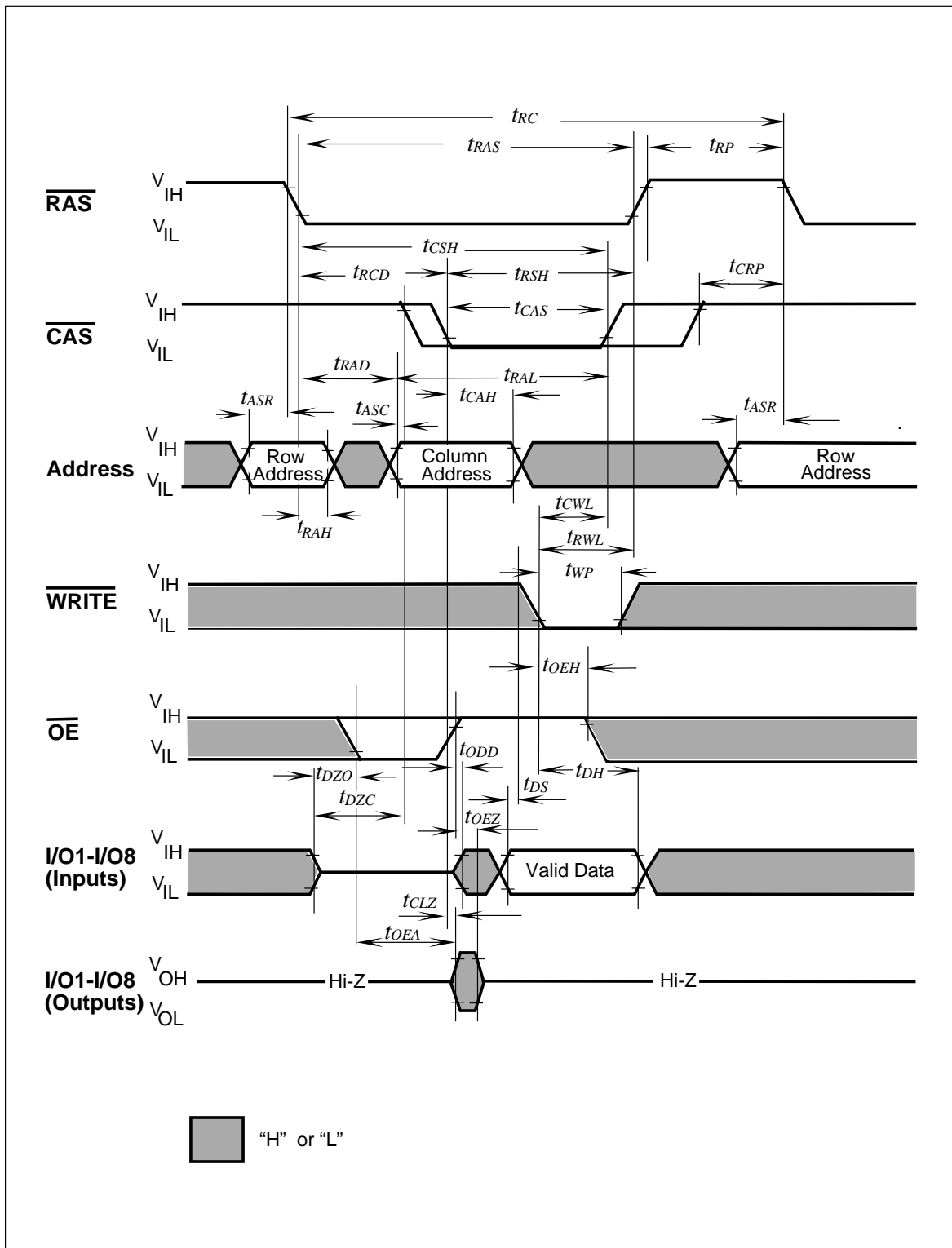

Write Cycle (\overline{OE} Controlled Write)

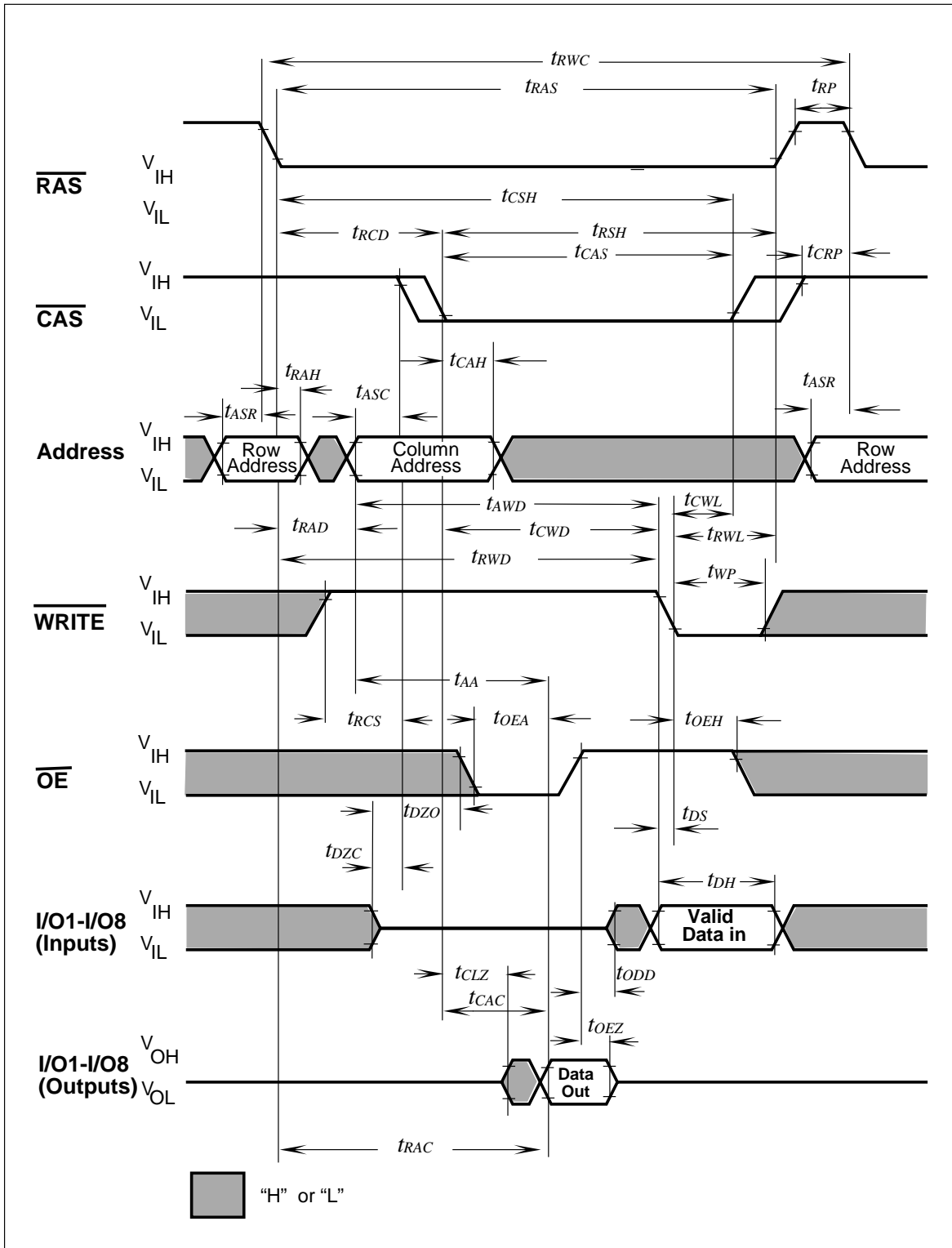

Read-Write (Read-Modify-Write) Cycle

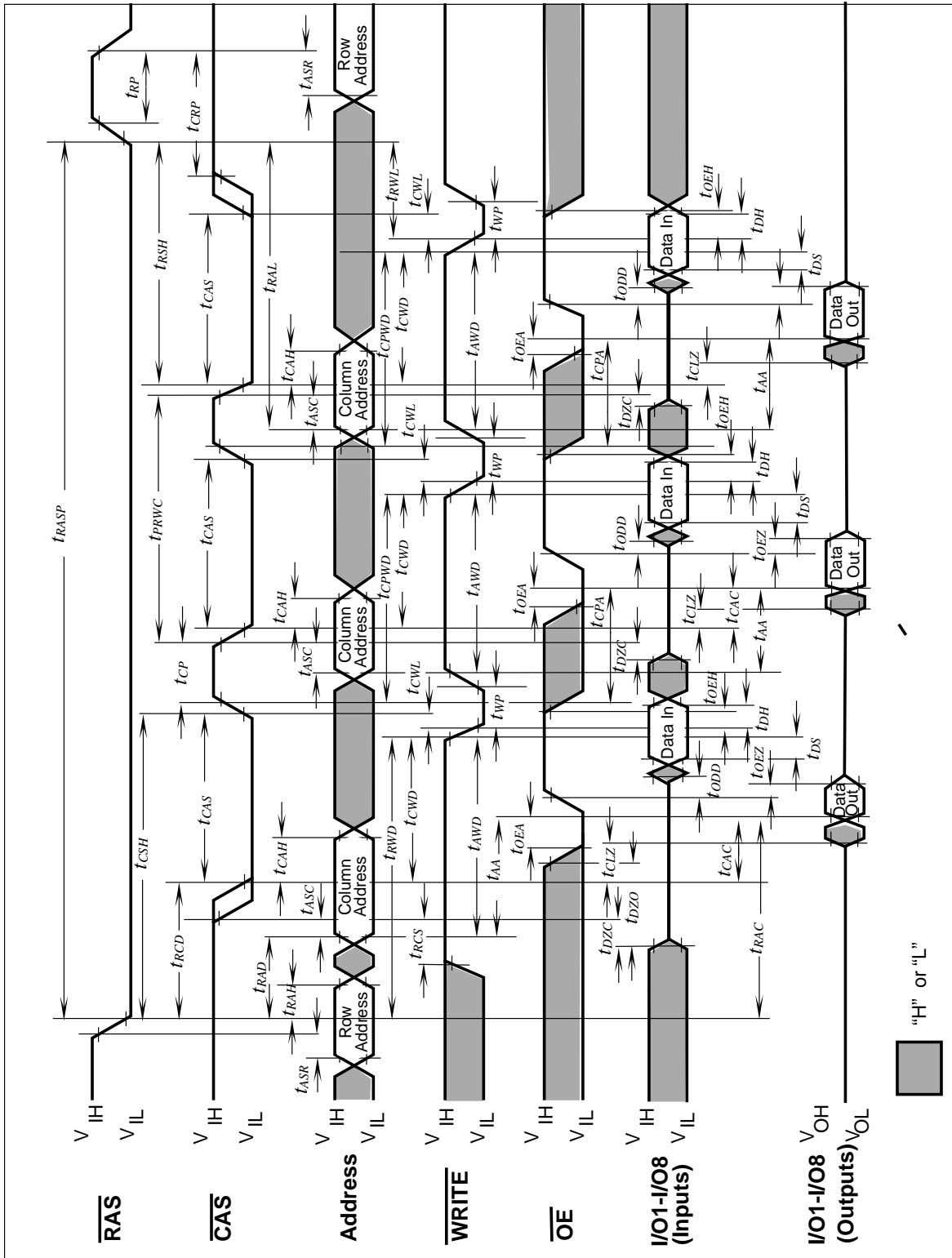

Fast Page Mode Read-Modify-Write Cycle

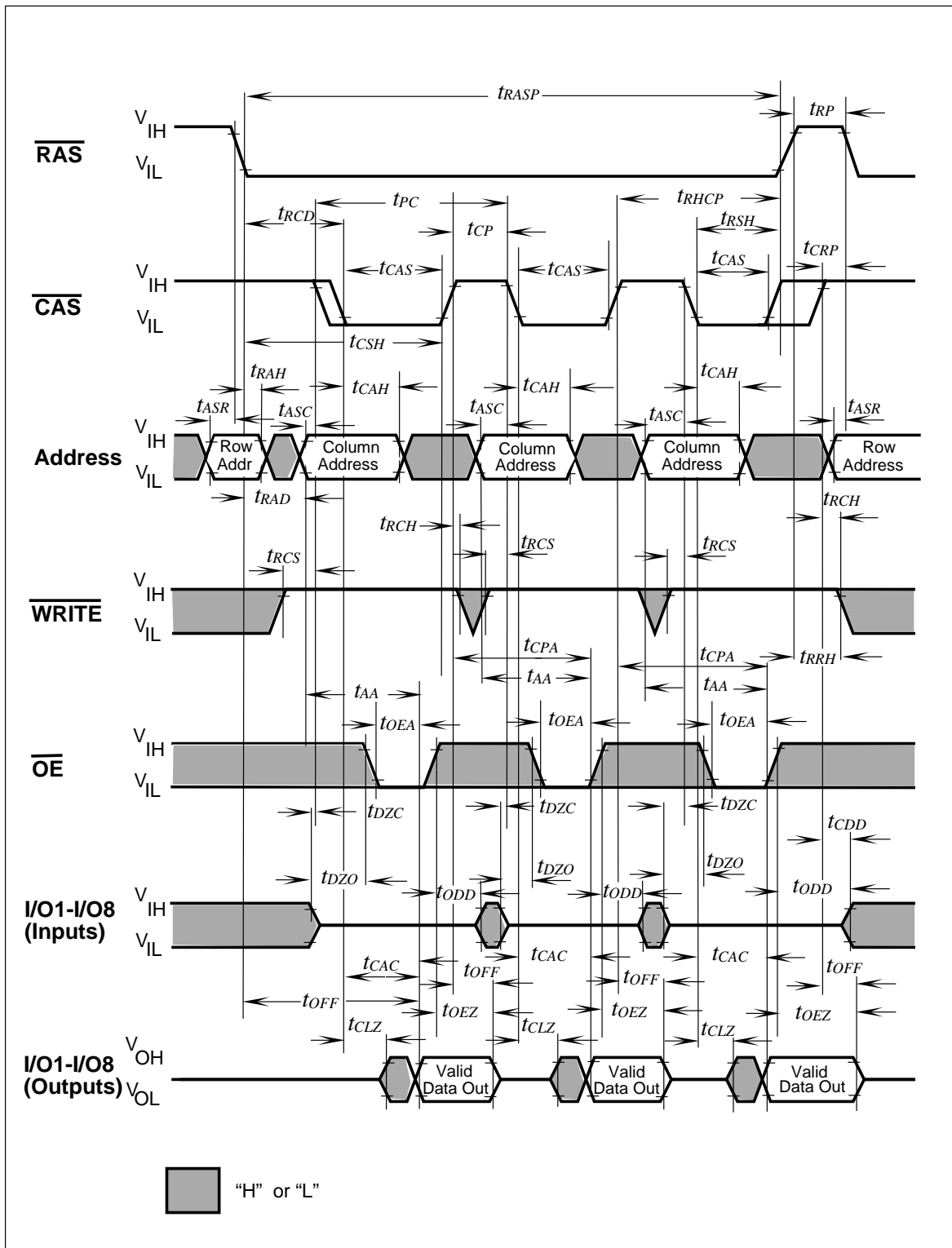

Fast Page Mode Read Cycle

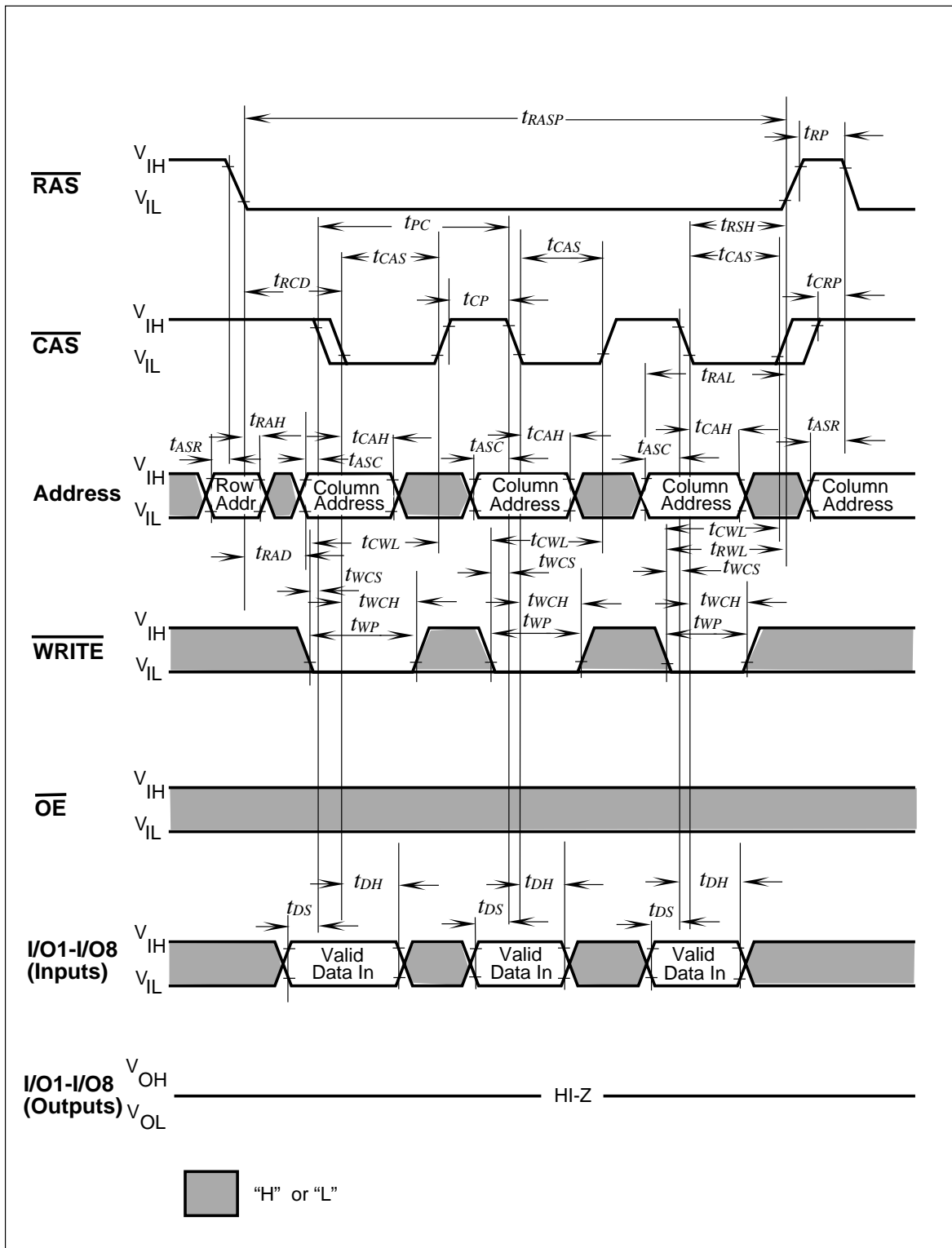

Fast Page Mode Early Write Cycle

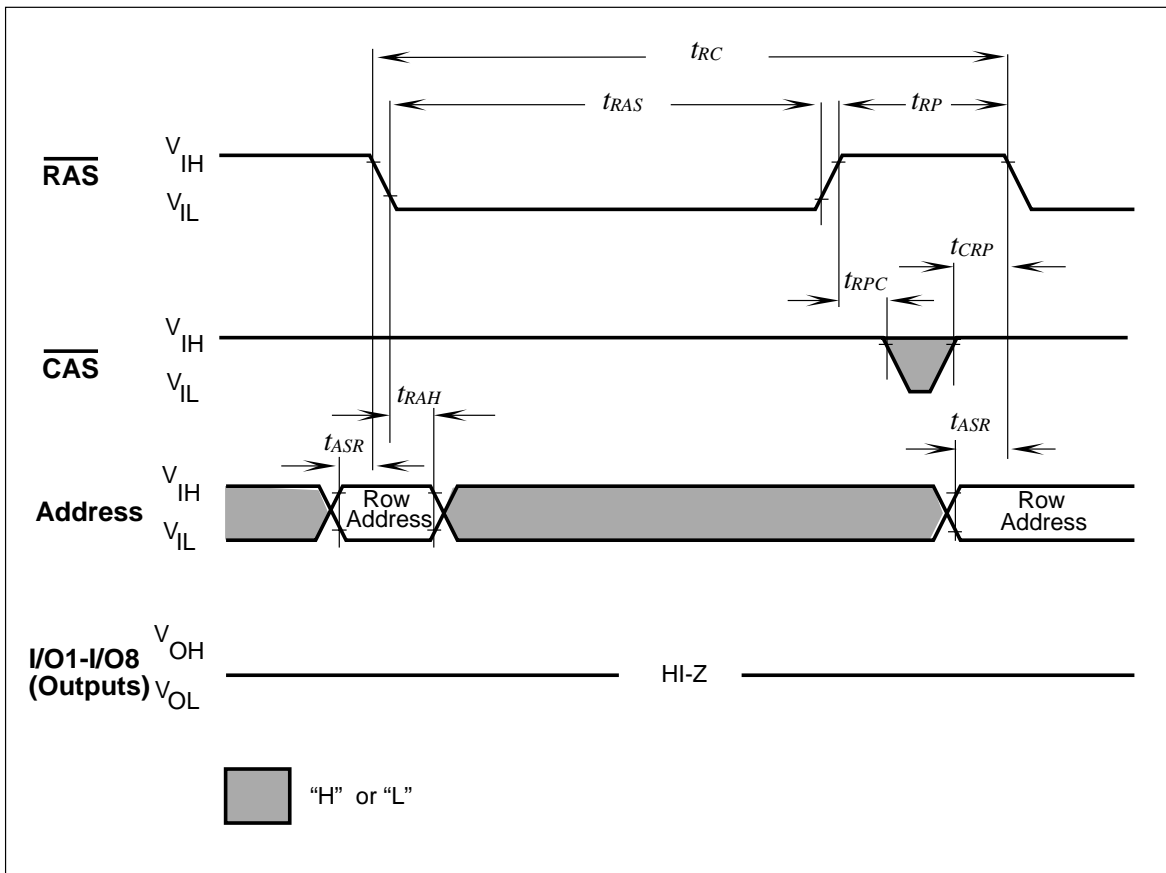

$\overline{\text{RAS}}$ -Only Refresh Cycle

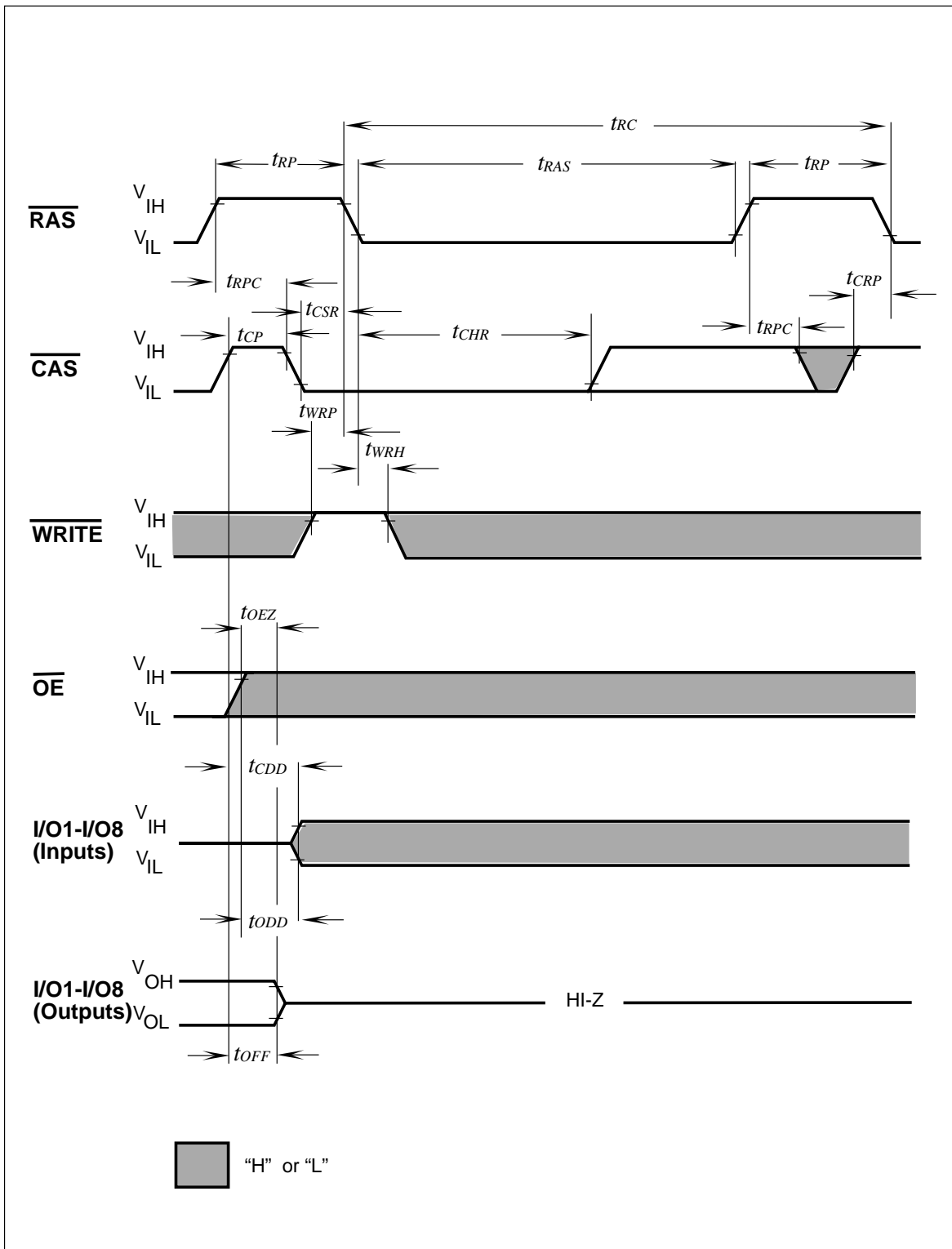

CAS-Before-RAS Refresh Cycle

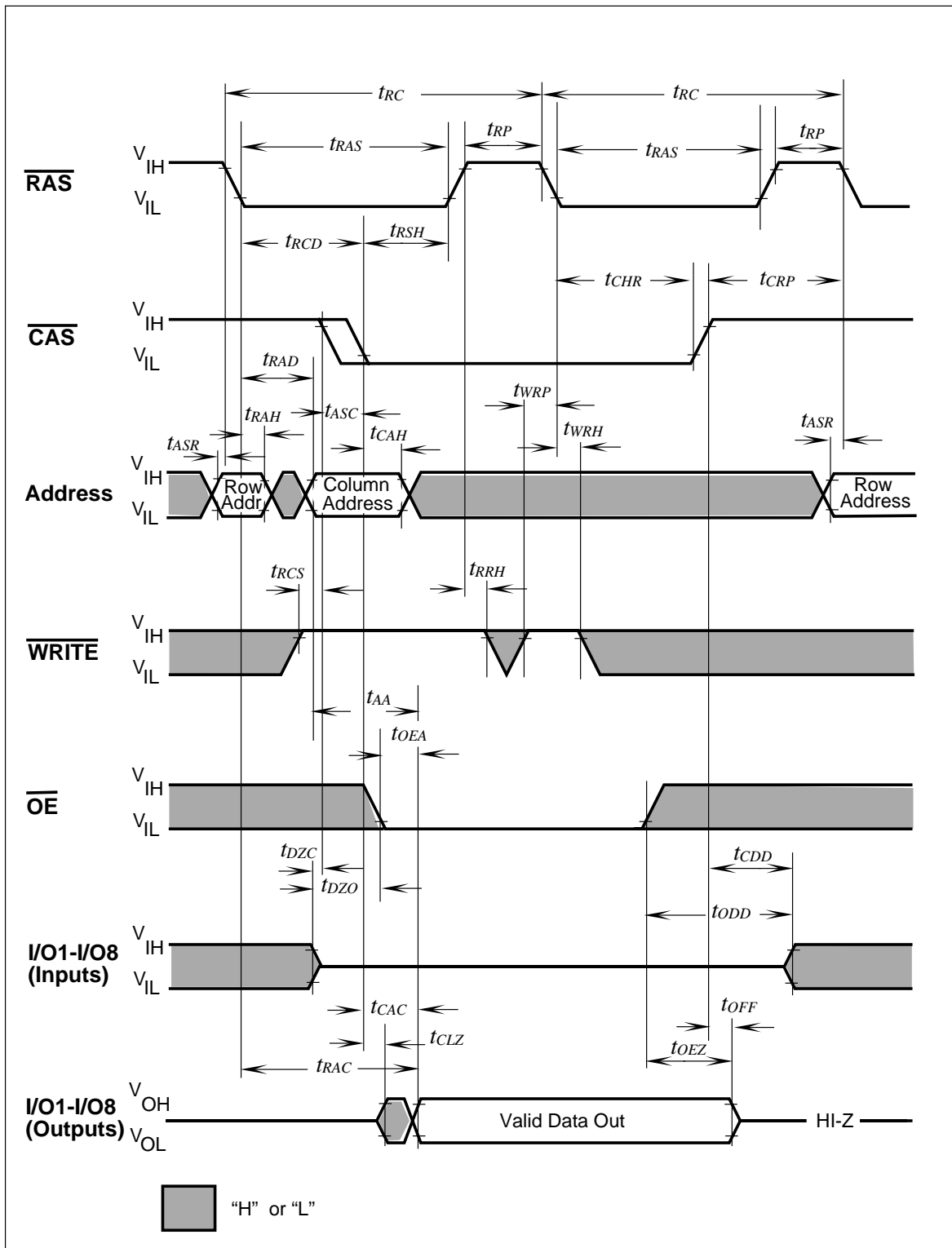

Hidden Refresh Cycle (Read)

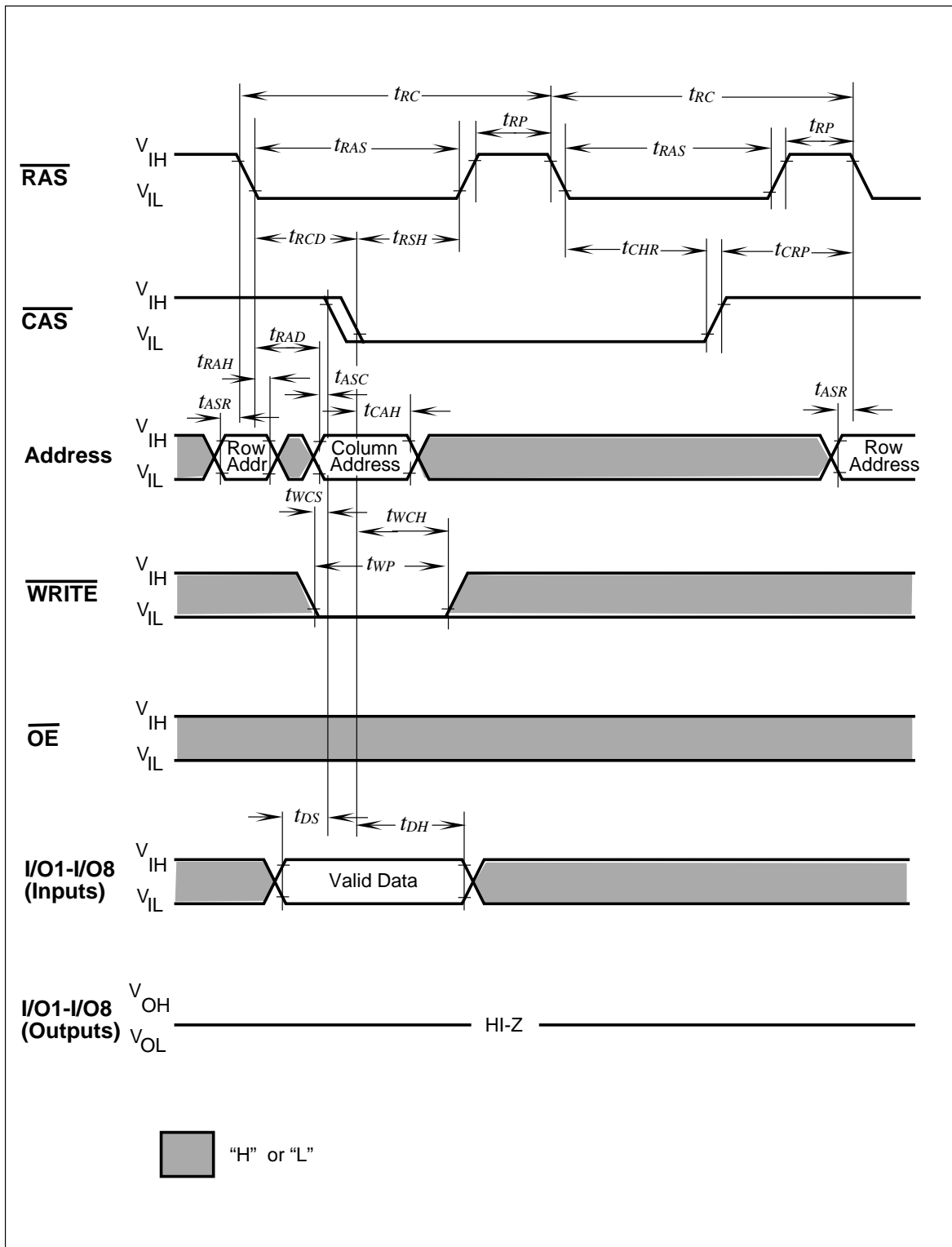

Hidden Refresh Cycle (Early Write)

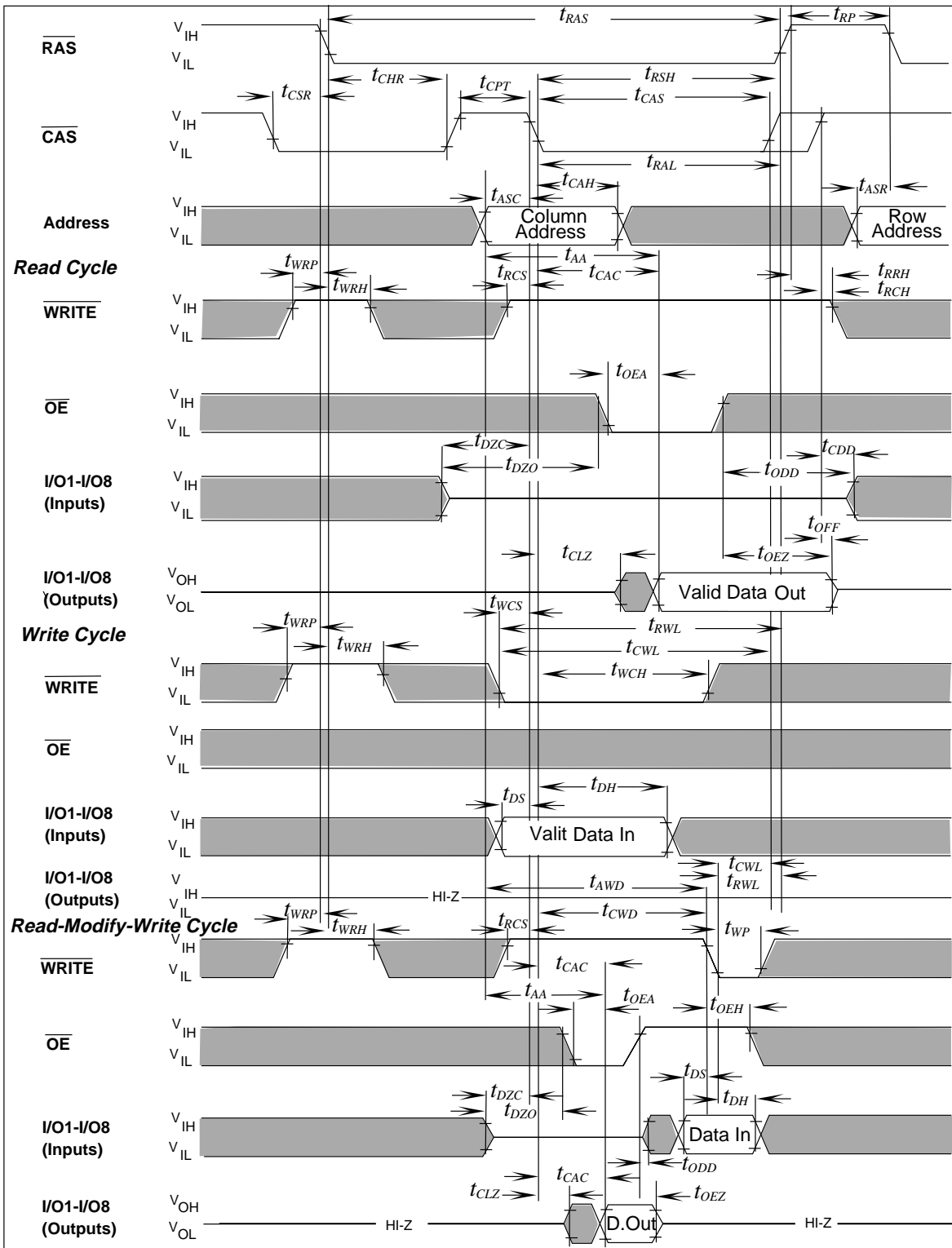

CAS-Before-RAS Refresh Counter Test Cycle

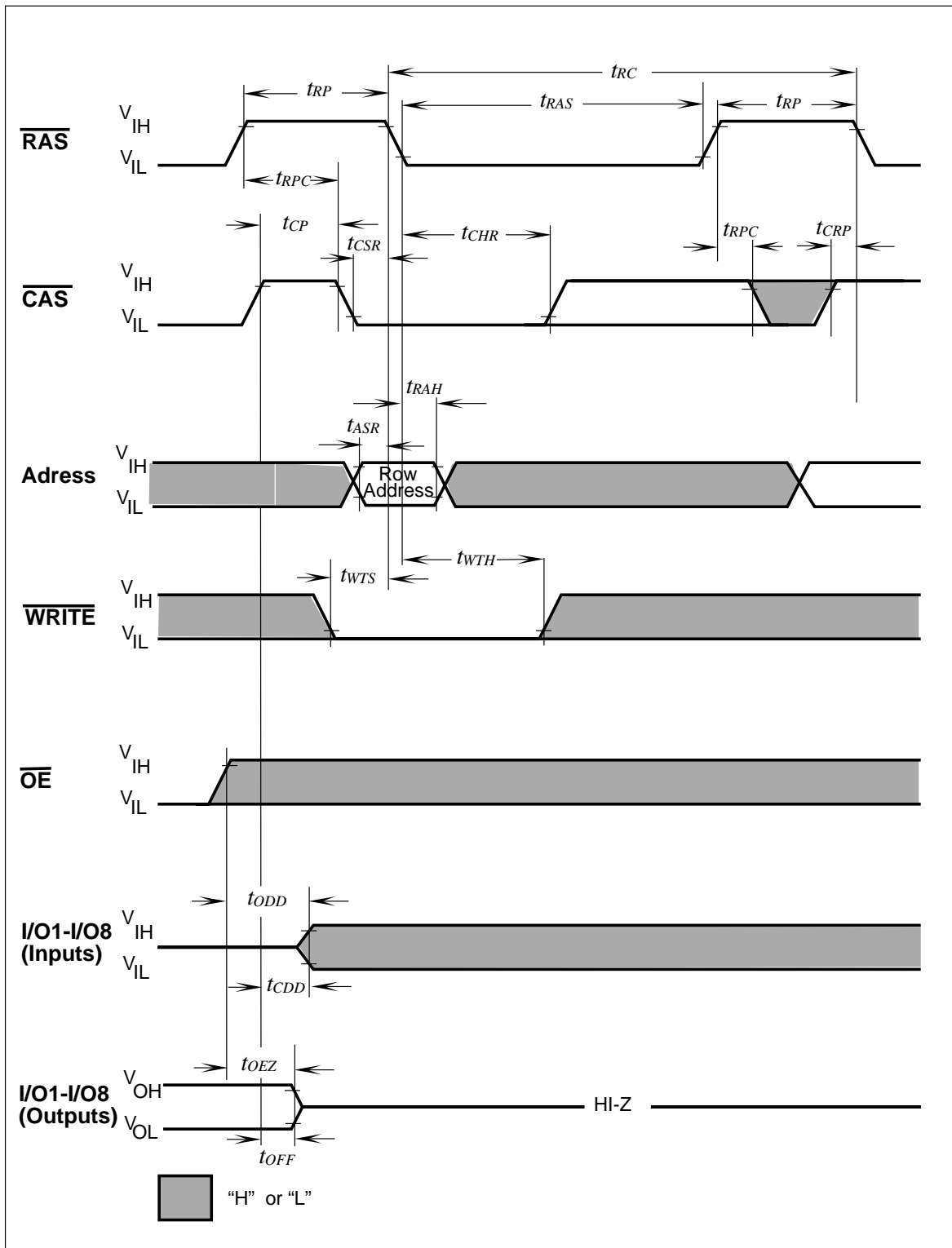

Test Mode Entry

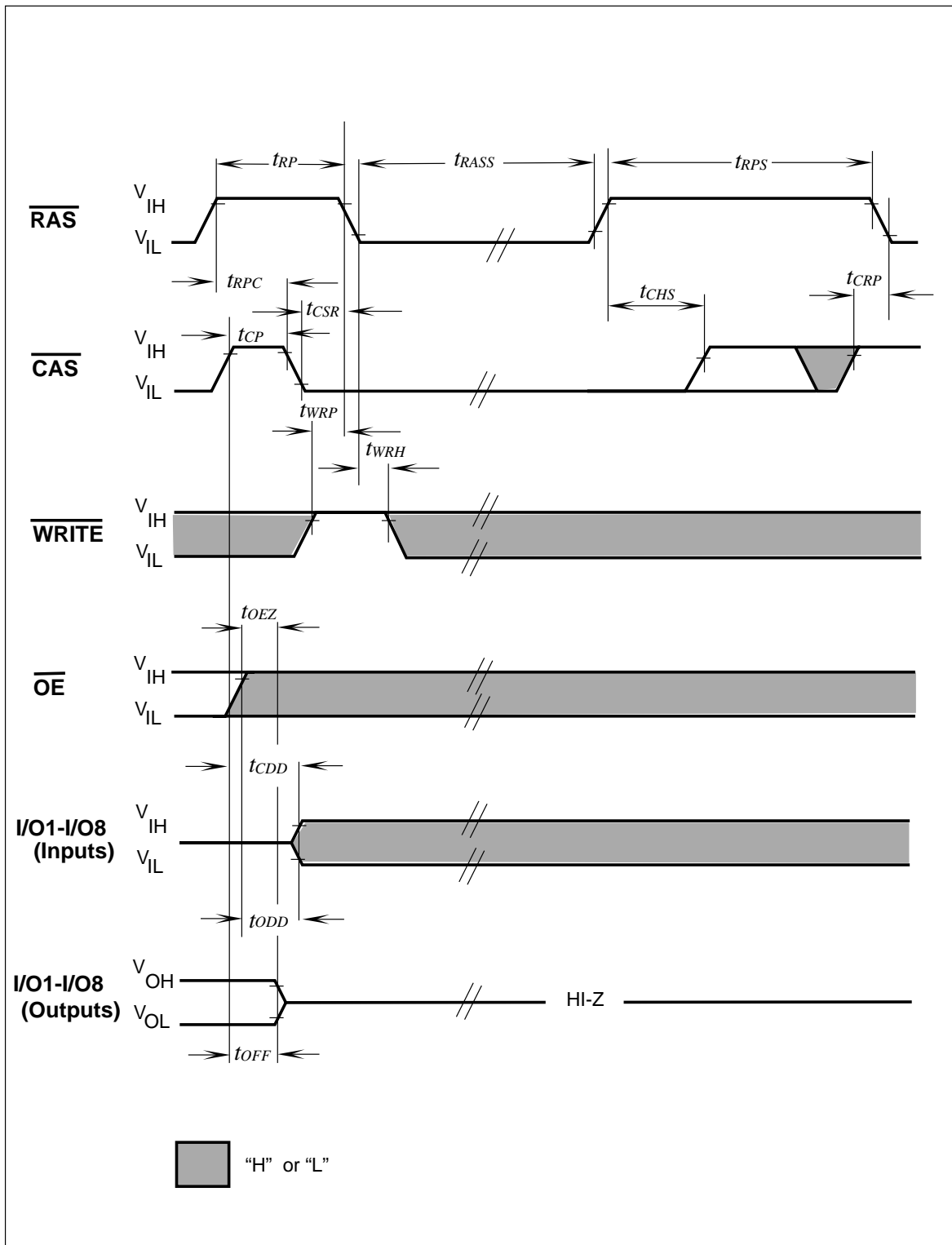

CAS-before-RAS Self Refresh

Package Outlines

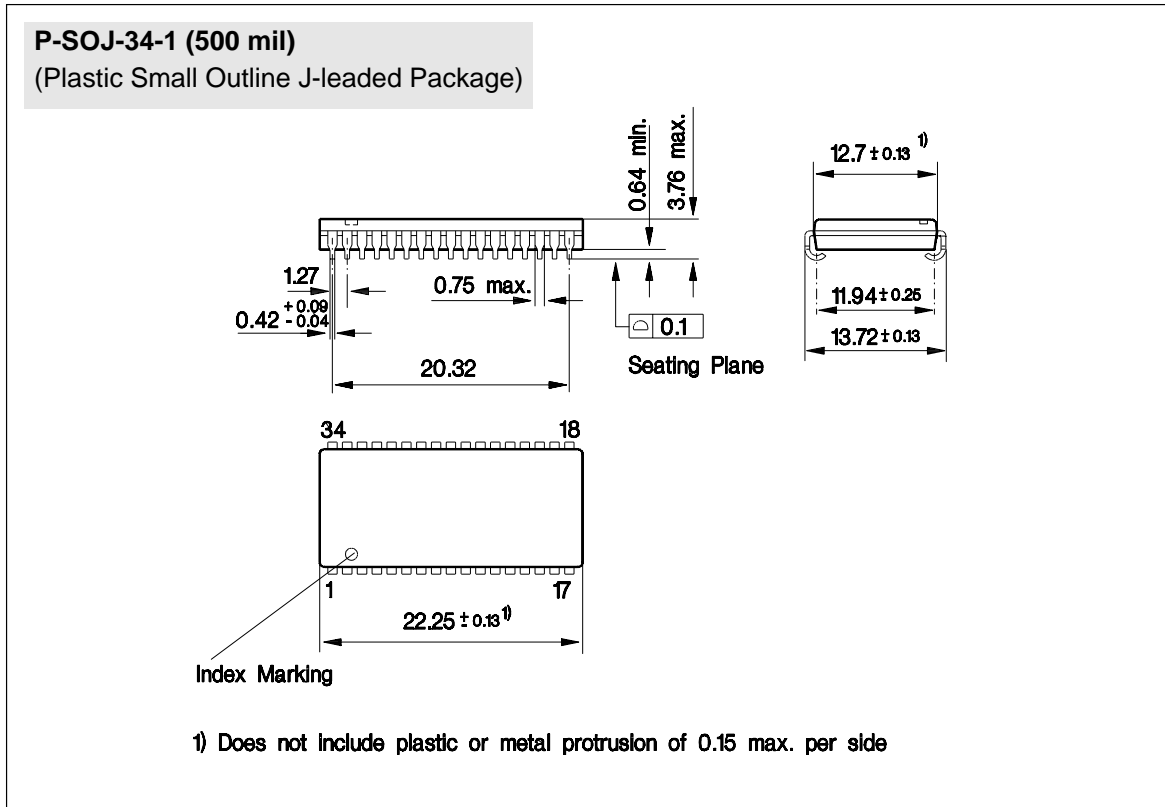

Sorts of Packing

Package outlines for tubes, trays etc. are contained in our Data Book "Package Information".

SMD = Surface Mounted Device

Dimensions in mm

P-TSOPII-34-1 (500 mil)
(Plastic Thin Small Outline Package Type)

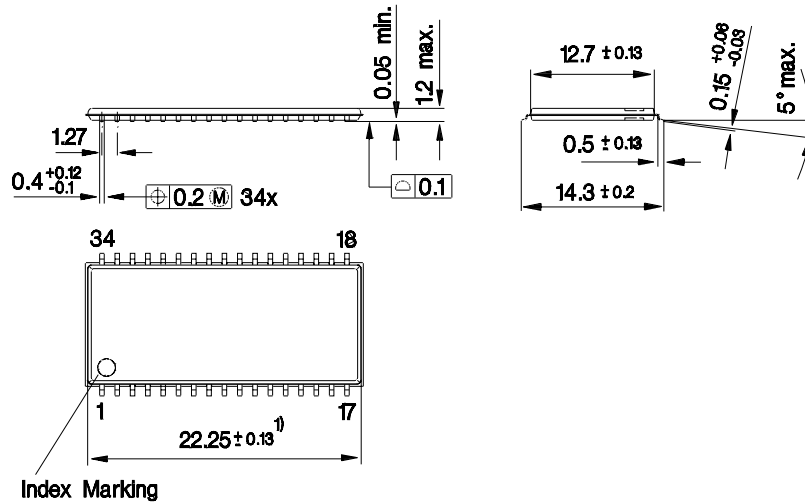

1) Does not include plastic or metal protrusion of 0.15 max. per side

Sorts of Packing

Package outlines for tubes, trays etc. are contained in our Data Book "Package Information".

SMD = Surface Mounted Device

Dimensions in mm