

Am79R79

Ringing Subscriber Line Interface Circuit

DISTINCTIVE CHARACTERISTICS

- Ideal for short-loop applications
- Ideal for ISDN terminal adaptor and fixed radio access applications
- On-chip ringing with on-chip ring-trip detector
- Low standby state power
- Battery operation:
 - V_{BAT1} : -40.5 V to -75 V
 - V_{BAT2} : -19 V to V_{BAT1}
- On-chip battery switching and feed selection
- On-hook transmission
- Two-wire impedance set by single external impedance
- Programmable constant-current feed
- Programmable Open Circuit voltage
- Programmable loop-detect threshold
- Current gain = 1000
- Ground-key detector
- Tip Open state for ground-start lines
- Polarity reversal option available
- Internal V_{EE} regulator (no external -5 V power supply required)
- Two on-chip relay drivers and snubber circuits (32 PLCC)

BLOCK DIAGRAM

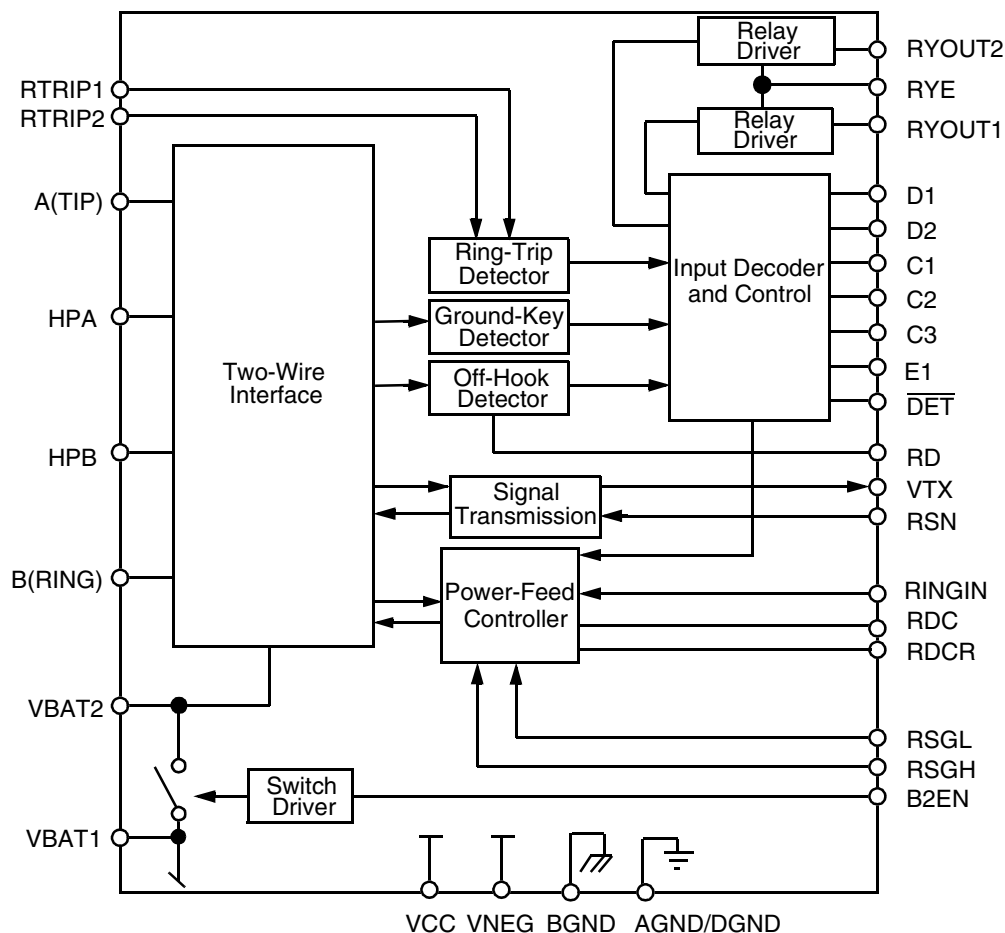

GENERAL DESCRIPTION

The AMD family of subscriber line interface circuit (SLIC) products provide the telephone interface functions required throughout the worldwide market. AMD SLIC devices address all major telephony markets including central office (CO), private branch exchange (PBX), digital loop carrier (DLC), fiber-in-the-loop (FITL), radio-in-the-loop (RITL), hybrid fiber coax (HFC), and video telephony applications.

The AMD SLIC devices offer support of BORSHT (battery feed, overvoltage protection, ringing, supervision, hybrid, and test) functions with features including current limiting, on-hook transmission, polarity reversal, Tip Open, and loop-current detection. These features allow reduction of linecard cost by minimizing component count, conserving board space, and supporting automated manufacturing.

The AMD SLIC devices provide the two- to four-wire hybrid function, DC-loop feed, and two-wire supervision. Two-wire termination is programmed by a scaled impedance network. Transhybrid balance can be achieved with an external balance circuit or simply programmed using a companion AMD codec device, the Am79C02/03/031 DSLAC™ device, the Am79Q02/021/03 Programmable Quad SLAC (QSLAC™) device, or the Am79Q5457/4457 Nonprogrammable QSLAC device.

The Am79R79 Ringing SLIC device is a bipolar monolithic SLIC that offers on-chip ringing. Now designers can achieve significant cost reductions at the system level for short-loop applications by integrating the ringing function on chip. Examples of such applications

would be ISDN terminal adaptors, fiber-in-the-loop, radio-in-the-loop, hybrid fiber/coax and video telephony (home-side) boxes. The Am79R79 Ringing SLIC can provide sufficient voltage to meet the stringent LSSGR five-ringer equivalent specification. Using a CMOS-compatible input waveform and wave shaping R-C network, the Am79R79 Ringing SLIC can provide trapezoidal wave ringing to meet various design requirements.

In order to further enhance the suitability of this device in short-loop, distributed switching applications, AMD has maximized power savings by incorporating battery switching on chip. The Am79R79 Ringing SLIC device switches between two battery supplies such that in the off-hook (active) state, a low battery is used to save power. In order to meet the Open Circuit voltage requirements of fax machines and maintenance termination units (MTU), the SLIC automatically switches to a higher voltage in the on-hook (standby) state.

Like all of the AMD SLIC devices, the Am79R79 Ringing SLIC device supports on-hook transmission, ring-trip detection, programmable loop-detect threshold, and is available with on-chip polarity reversal. The Am79R79 Ringing SLIC device is a programmable constant-current feed device with two on-chip relay drivers to operate external relays. Several performance grades are available to meet both CCITT and LSSGR requirements, including various longitudinal balance options. This unique device is available in the proven AMD 75 V bipolar process in the 32-pin PLCC package.

ORDERING INFORMATION

Standard Products

AMD standard products are available in several packages and operating ranges. The order number (Valid Combination) is formed by a combination of the elements below

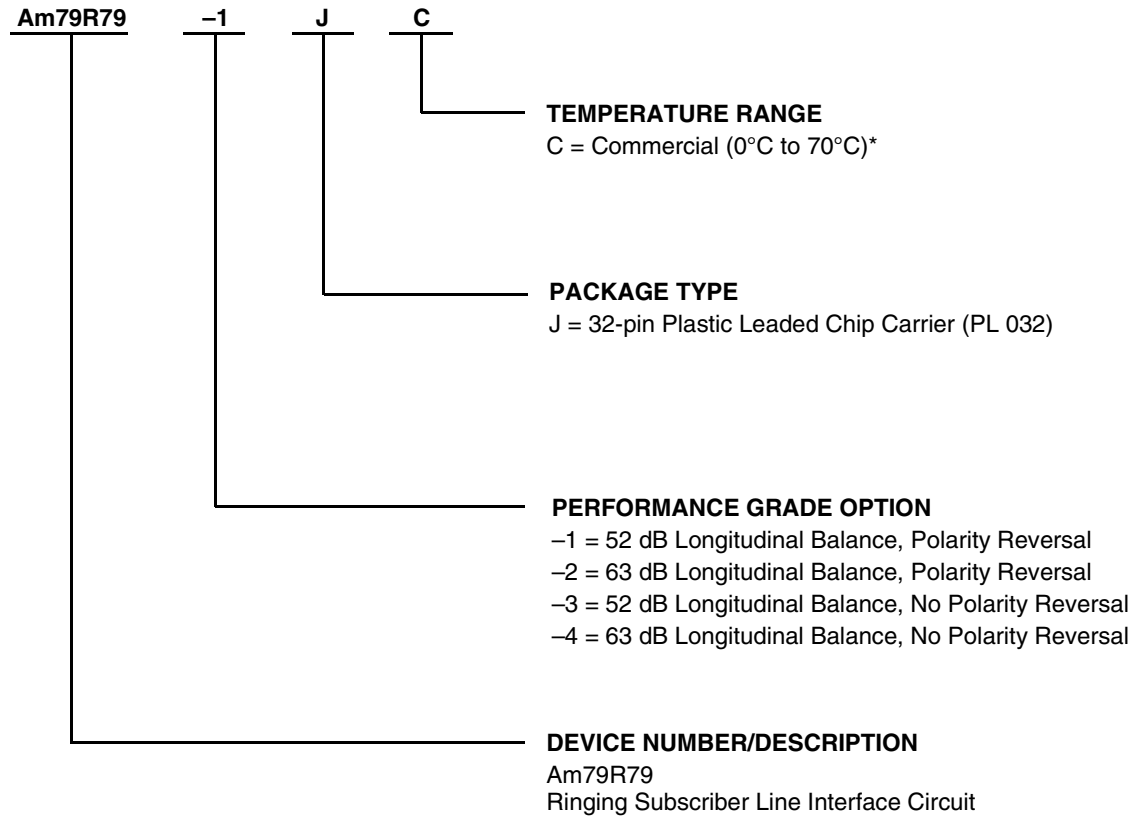

Valid Combinations		
Am79R79	-1	JC
	-2	
	-3	
	-4	

Valid Combinations

Valid Combinations list configurations planned to be supported in volume for this device. Consult the local AMD sales office to confirm availability of specific valid combinations, to check on newly released combinations, and to obtain additional data on AMD's standard military grade products.

Note:

* Functionality of the device from 0°C to +70°C is guaranteed by production testing. Performance from -40°C to +85°C is guaranteed by characterization and periodic sampling of production units.

CONNECTION DIAGRAM

Top View

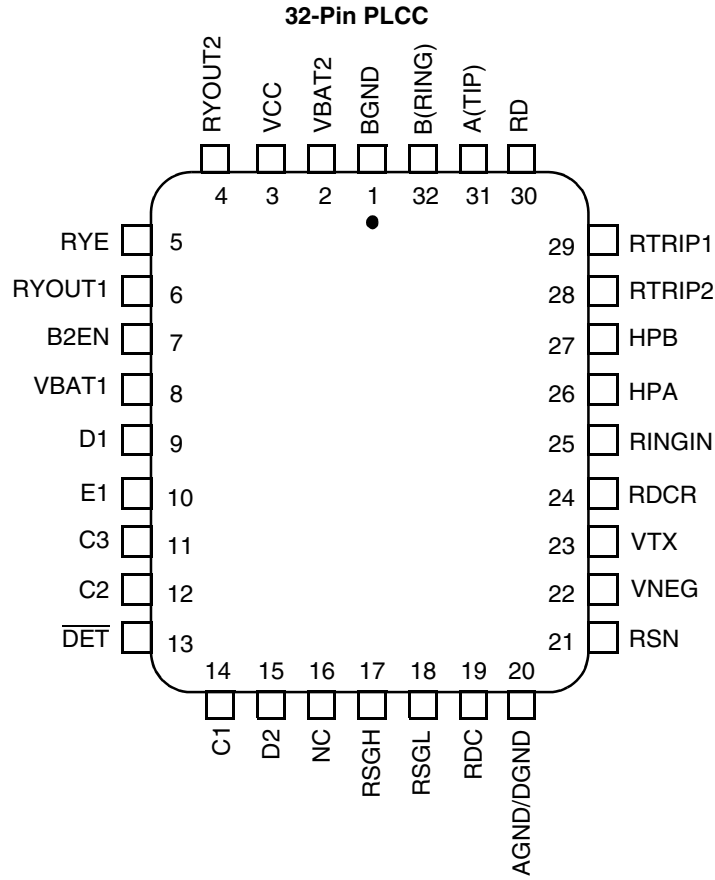

Notes:

- 1. Pin 1 is marked for orientation.
- 2. NC = No connect

PIN DESCRIPTIONS

Pin Names	Type	Description
AGND/DGND	Gnd	Analog and Digital ground
A(TIP)	Output	Output of A(TIP) power amplifier
B2EN	Input	VBAT2 Enable. Logic Low enables operation from V_{BAT2} . Logic High enables operation from V_{BAT1} . TTL compatible.
BGND	Gnd	Battery (power) ground
B(RING)	Output	Output of B(RING) power amplifier
C3–C1	Input	Decoder. TTL compatible. C3 is MSB and C1 is LSB.
D1	Input	Relay1 Control. TTL compatible. Logic Low activates the Relay1 relay driver.
D2	Input	(Option) Relay2 Control. TTL compatible. Logic Low activates the Relay2 relay driver.
\overline{DET}	Output	Switchhook Detector. Logic Low indicates that the selected detector is tripped. Logic inputs C3–C1 and E1 select the detector. Open-collector with a built-in 15 k Ω pull-up resistor.
E1	Input	(Option) Ground-Key Enable. A logic High selects the off-hook detector. A logic Low selects the ground-key detector. TTL compatible.
HPA	Capacitor	High-pass filter capacitor. A(TIP) side of high-pass filter capacitor.
HPB	Capacitor	High-pass filter capacitor. B(RING) side of high-pass filter capacitor.
RD	Resistor	Detector resistor. Detector threshold set and filter pin.
RDC	Resistor	DC feed resistor. Connection point for the DC feed current programming network, which also connects to the receiver summing node (RSN). V_{RDC} is negative for normal polarity and positive for reverse polarity.
RDCR	—	Connection point for feedback during ringing.
RINGIN	Input	Ring Signal Input. Pin for ring signal input. Square-wave shaped by external RC filter. Requires 50% duty cycle. CMOS-compatible input.
RSGH	Input	Saturation Guard High. Pin for resistor to adjust Open Circuit voltage when operating from V_{BAT1} .
RSGL	Input	Saturation Guard Low. Pin for resistor to adjust the anti-saturation cut-in voltage when operating from both V_{BAT1} and V_{BAT2} .
RSN	Input	Receive Summing Node. The metallic current (AC and DC) between A(TIP) and B(RING) is equal to 1000 x the current into this pin. The networks that program receive gain, two-wire impedance, and feed resistance all connect to this node.
RTRIP1	Input	Ring-trip detector. Ring-trip detector threshold set and filter pin.
RTRIP2	Input	Ring-trip detector. Ring-trip detector threshold offset (switch to V_{BAT1}). For power conservation in any nonringing state, this switch is open.
RYE	Output	Common Emitter of RYOUT1/RYOUT2. Emitter output of RYOUT1 and RYOUT2. Normally connected to relay ground.
RYOUT1	Output	Relay/switch driver. Open-collector driver with emitter internally connected to RYE.
RYOUT2	Output	(Option) Relay/switch driver. Open-collector driver emitter internally connected to RYE.
VBAT1	Battery	Battery supply and connection to substrate.
VBAT2	Battery	Power supply to output amplifiers. Connect to off-hook battery through a diode.
VCC	Power	Positive analog power supply.
VNEG	Power	Negative analog power supply. This pin is the return for the intern VEE regulator.
VTX	Output	Transmit Audio. This output is 0.5066 gain version of the A(TIP) and B(RING) metallic voltage. VTX also sources the two-wire input impedance programming network.

ABSOLUTE MAXIMUM RATINGS

Storage temperature	-55°C to +150°C
V _{CC} with respect to AGND/DGND	0.4 V to +7 V
V _{NEG} with respect to AGND/DGND	0.4 V to V _{BAT2}
V _{BAT2}	V _{BAT1} to GND
V _{BAT1} with respect to AGND/DGND:	
Continuous	+0.4 V to -80 V
10 ms	+0.4 V to -85 V
BGND with respect to AGND/DGND.....	+3 V to -3 V
A(TIP) or B(RING) to BGND:	
Continuous	V _{BAT1} -5 V to +1 V
10 ms (f = 0.1 Hz)	V _{BAT1} -10 V to +5 V
1 μs (f = 0.1 Hz)	V _{BAT1} -15 V to +8 V
250 ns (f = 0.1 Hz)	V _{BAT1} -20 V to +12 V
Current from A(TIP) or B(RING).....	±150 mA
RYOUT1, RYOUT2 current.....	75 mA
RYOUT1, RYOUT2 voltage	RYE to +7 V
RYOUT1, RYOUT2 transient	RYE to +10 V
RYE voltage	BGND to V _{BAT1}
C3-C1, D2-D1, E1, B2EN, and RINGIN	
Input voltage	-0.4 V to V _{CC} + 0.4 V
Maximum power dissipation, continuous,	
T _A = 85°C, No heat sink (See note):	
In 32-pin PLCC package.....	1.33 W
Thermal data:	θ _{JA}
In 32-pin PLCC package.....	45°C/W typ

Note: Thermal limiting circuitry on chip will shut down the circuit at a junction temperature of about 165°C. The device should never see this temperature and operation above 145°C junction temperature may degrade device reliability. See the SLIC Packaging Considerations for more information.

Stresses above those listed under Absolute Maximum Ratings may cause permanent device failure. Functionality at or above these limits is not implied. Exposure to Absolute Maximum Ratings for extended periods may affect device reliability.

OPERATING RANGES

Commercial (C) Devices

Ambient temperature	0°C to +70°C*
V _{CC}	4.75 V to 5.25 V
V _{NEG}	-4.75 V to V _{BAT2}
V _{BAT1}	-40.5 V to -75 V
V _{BAT2}	-19 V to V _{BAT1}
AGND/DGND.....	0 V
BGND with respect to	
AGND/DGND	-100 mV to +100 mV
Load resistance on VTX to ground.....	20 kΩ min

The Operating Ranges define those limits between which the functionality of the device is guaranteed.

** Functionality of the device from 0°C to +70°C is guaranteed by production testing. Performance from -40°C to +85°C is guaranteed by characterization and periodic sampling of production units.*

ELECTRICAL CHARACTERISTICS

Description	Test Conditions (See Note 1)	Min	Typ	Max	Unit	Note	
Transmission Performance							
2-wire return loss	200 Hz to 3.4 kHz (Test Circuit D)	26			dB	1, 4, 6	
Z_{VTX} , analog output impedance			3	20	Ω	4	
V_{VTX} , analog output offset voltage	0°C to +70°C	-35		+35	mV	4	
	-40°C to +85°C	-40		+40			
Z_{RSN} , analog input impedance			1	20	Ω		
Overload level, 2-wire and 4-wire, off hook	Active state	2.5			Vpk	2a	
Overload level, 2-wire	On hook, $R_{LAC} = 600 \Omega$	0.88			Vrms	2b	
THD (Total Harmonic Distortion)	+3 dBm, BAT2 = -24 V		-64	-50	dB	5	
THD, on hook, OHT state	0 dBm, $R_{LAC} = 600 \Omega$ BAT1 = -75 V			-40			
Longitudinal Performance (See Test Circuit C)							
Longitudinal to metallic L-T, L-4 balance	200 Hz to 1 kHz normal polarity	-1, -3*	52		dB	4	
	reverse polarity	-2	54				
	normal polarity, -40°C to +85°C	-2, -4	58				
	1 kHz to 3.4 kHz normal polarity	-1, -3*	52				
	reverse polarity	-2	54				
	normal polarity, -40°C to +85°C	-2, -4	54				
	Longitudinal signal generation 4-L	200 Hz to 800 Hz normal polarity	42				
	Longitudinal current per pin (A or B)	Active or OHT state	12	28			
Longitudinal impedance at A or B	0 to 100 Hz, $T_A = +25^\circ\text{C}$		25		Ω/pin		
Idle Channel Noise							
C-message weighted noise	0°C to +70°C		+7	+11	dBrnC	4	
	-40°C to +85°C			+12			
Psophometric weighted noise	0°C to +70°C		-83	-79	dBmp	4	
	-40°C to +85°C			-78			
Insertion Loss and Four- to Four-Wire Balance Return Signal (See Test Circuits A and B)							
Gain accuracy	4- to 2-wire	0 dBm, 1 kHz	-0.20	0	+0.20	3	
Gain accuracy	2- to 4-wire and 4- to 4-wire	0 dBm, 1 kHz	-6.22	-6.02	-5.82		
Gain accuracy	4- to 2-wire	OHT state, on hook	-0.35	0	+0.35		
Gain accuracy	2- to 4-wire and 4- to 4-wire	OHT state, on hook	-6.37	-6.02	-5.77		
Gain accuracy over frequency	300 to 3400 Hz relative to 1 kHz	0°C to +70°C	-0.10		+0.10	dB	
		-40°C to +85°C	-0.15		+0.15		
Gain tracking	+3 dBm to -55 dBm relative to 0 dBm	0°C to +70°C	-0.10		+0.10	3, 4	
		-40°C to +85°C	-0.15		+0.15		
Gain tracking OHT state, on hook	0 dBm to -37 dBm +3 dBm to 0 dBm	0°C to +70°C	-0.10		+0.10	3	
		-40°C to +85°C	-0.15		+0.15		
Group delay	0 dBm, 1 kHz		3		μs	1, 4, 6	

Note:

* Performance Grade

ELECTRICAL CHARACTERISTICS (continued)

Description	Test Conditions (See Note 1)	Min	Typ	Max	Unit	Note	
Line Characteristics							
I_L , Loop-current accuracy	I_L in constant-current region, B2EN = 0	$0.915I_L$	I_L	$1.085I_L$	mA		
I_L , Long loops, Active state	$R_{LDC} = 600 \Omega$, RSGL = open	20	21.7				
	$R_{LDC} = 750 \Omega$, RSGL = short	20					
I_L , Accuracy, Standby state	$I_L = \frac{ V_{BAT1} - 10V}{R_L + 400}$	$0.8I_L$	I_L	$1.2I_L$			
	I_L = constant-current region $T_A = 25^\circ\text{C}$	18	27	39			
	-40°C to $+85^\circ\text{C}$	18	27			4	
$I_{L\text{LIM}}$	Active, A and B to ground		55	110			
	OHT, A and B to ground		55				4
I_L , Loop current, Open Circuit state	$R_L = 0$			100		μA	
I_A , Pin A leakage, Tip Open state	$R_L = 0$			100			
I_B , Pin B current, Tip Open state V_A , Standby, ground-start signaling	B to ground		34		mA		
	A to $-48\text{ V} = 7\text{ k}\Omega$, B to ground = $100\ \Omega$	-7.5	-5		V	4	
V_{AB} , Open Circuit voltage		42.8				8	
Power Supply Rejection Ratio ($V_{\text{RIPPLE}} = 100\text{ mVrms}$), Active Normal State							
V_{CC}	50 Hz to 3400 Hz	33	50		dB	5	
V_{NEG}	50 Hz to 3400 Hz	30	40				
V_{BAT1}	50 Hz to 3400 Hz	30	50				
V_{BAT2}	50 Hz to 3400 Hz	30	50				
Power Dissipation							
On hook, Open Circuit state	V_{BAT1}		48	100	mW		
On hook, Standby state	V_{BAT2}		55	80		10	
On hook, OHT state	V_{BAT1}		200	300			
On hook, Active state	V_{BAT1}		220	350			
Off hook, Standby state	V_{BAT1} or V_{BAT2}	$R_L = 300\ \Omega$	2000	2800		10	
Off hook, OHT state	V_{BAT1}	$R_L = 300\ \Omega$	2000	2200			
Off hook, Active state	V_{BAT2}	$R_L = 300\ \Omega$	550	750			
Supply Currents							
I_{CC} , On-hook V_{CC} supply current	Open Circuit state		3.0	4.5	mA		
	Standby state		3.2	5.5			
	OHT state		6.2	8.0			
	Active state–normal		6.5	9.0			
I_{NEG} , On-hook V_{NEG} supply current	Open Circuit state		0.1	0.2			
	Standby state		0.1	0.2			
	OHT state		0.7	1.1			
	Active state–normal		0.7	1.1			
I_{BAT} , On-hook V_{BAT} supply current	Open Circuit state		0.45	1.0			
	Standby state		0.6	1.5			
	OHT state		2.0	4.0			
	Active state–normal		2.7	5.0			

ELECTRICAL CHARACTERISTICS (continued)

Description	Test Conditions (See Note 1)	Min	Typ	Max	Unit	Note
Logic Inputs (C3–C1, D2–D1, E1, and B2EN)						
V _{IH} , Input High voltage		2.0			V	
V _{IL} , Input Low voltage				0.8		
I _{IH} , Input High current		-75		40	μA	
I _{IL} , Input Low current		-400				
Logic Output DET						
V _{OL} , Output Low voltage	I _{OUT} = 0.8 mA, 15 kΩ to V _{CC}			0.40	V	
V _{OH} , Output High voltage	I _{OUT} = -0.1 mA, 15 kΩ to V _{CC}	2.4				
Ring-Trip Detector Input						
Ring detect accuracy	$IRTD = \left(\frac{ BAT1 - 1}{RRT1} + 24 \mu A \right) \cdot 335$	-10		+10	%	
Ring Signal						
V _{AB} , Ringing	Bat1 = -75 V, ringload = 1570 Ω	66	69		V _{pk}	7
V _{AB} Ringing offset	V _{RINGIN} = 2.5 V	-10	0	10	V	
ΔV _{AB} /ΔV _{RINGIN} (RINGIN gain)		150	180	210		
Ground-Key Detector Thresholds						
Ground-key resistive threshold	B to ground	2	5	10	kΩ	
Ground-key current threshold	B to ground		11		mA	
Loop Detector						
R _{LTH} , Loop-resistance detect threshold	Active, V _{BAT1}	-20		20	%	9
	Active, V _{BAT2}	-20		20		
	Standby	-12		12		
Relay Driver Output (RELAY1 and 2)						
V _{OL} , On voltage (each output)	I _{OL} = 30 mA		+0.25	+0.4	V	4
V _{OL} , On voltage (each output)	I _{OL} = 40 mA		+0.30	+0.8		
I _{OH} , Off leakage (each output)	V _{OH} = +5 V			100	μA	
Zener breakover (each output)	I _Z = 100 μA	6.6	7.9		V	
Zener on voltage (each output)	I _Z = 30 mA		11			

RELAY DRIVER SCHEMATIC

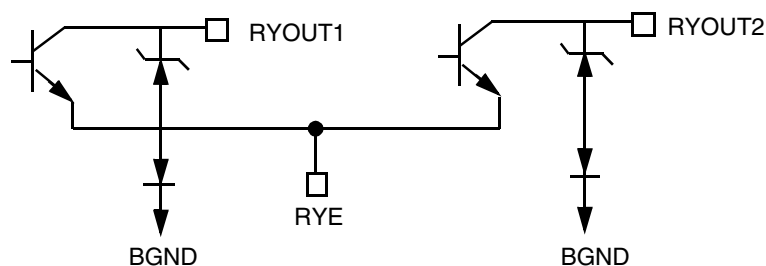

Notes:

- Unless otherwise noted, test conditions are $BAT1 = -75\text{ V}$, $BAT2 = -24\text{ V}$, $V_{CC} = +5\text{ V}$, $V_{NEG} = -5\text{ V}$, $R_L = 600\ \Omega$, $R_{DC1} = 80\text{ k}\Omega$, $R_{DC2} = 20\text{ k}\Omega$, $R_D = 75\text{ k}\Omega$, no fuse resistors, $C_{HP} = 0.018\ \mu\text{F}$, $C_{DC} = 1.2\ \mu\text{F}$, $D_1 = D_2 = 1N400x$, two-wire AC input impedance (ZSL) is a $600\ \Omega$ resistance synthesized by the programming network shown below. $R_{SGL} = \text{open}$, $R_{SGH} = \text{open}$, $R_{DCR} = 2\text{ k}\Omega$, $R_{RT1} = 430\text{ k}\Omega$, $R_{RT2} = 12\text{ k}\Omega$, $C_{RT} = 1.5\ \mu\text{F}$, $R_{SLEW} = 100\text{ k}\Omega$, $C_{SLEW} = 0.33\ \mu\text{F}$.

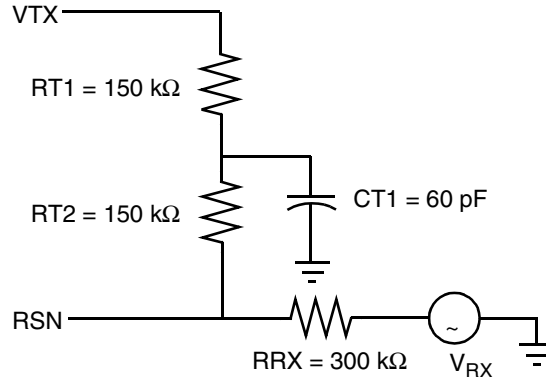

- Overload level is defined when $THD = 1\%$.
 - Overload level is defined when $THD = 1.5\%$.
- Balance return signal is the signal generated at V_{TX} by V_{RX} . This specification assumes that the two-wire AC load impedance matches the programmed impedance.
- Not tested in production. This parameter is guaranteed by characterization or correlation to other tests.
- This parameter is tested at 1 kHz in production. Performance at other frequencies is guaranteed by characterization.
- Group delay can be greatly reduced by using a Z_T network such as that shown in Note 1 above. The network reduces the group delay to less than $2\ \mu\text{s}$ and increases 2WRL. The effect of group delay on linecard performance may also be compensated for by synthesizing complex impedance with the QSLAC or DSLAC device.
- 70 Vpk provides 50 Vrms with a crest factor of 1.25 to a load of $1400\ \Omega$ with $2 \cdot R_f = 100$, and $R_{line} = 70\ \Omega$ ($1570\ \Omega$).
- Open Circuit V_{AB} can be modified using RSGH.
- R_D must be greater than $56\text{ k}\Omega$. Refer to Table 2 for typical value of R_{LTH} .
- Lower power is achieved by switching into low-battery state in standby. Standby loop current is returned to V_{BAT1} regardless of the battery selected.

Table 1. SLIC Decoding

State	C3 C2 C1	2-Wire Status	(DET) Output		Battery Selection
			E1 = 1	E1 = 0	
0	0 0 0	Open Circuit	Ring trip	Ring trip	B2EN
1	0 0 1	Ringing	Ring trip	Ring trip	
2	0 1 0	Active	Loop detector	Ground key	
3	0 1 1	On-hook TX (OHT)	Loop detector	Ground key	
4	1 0 0	Tip Open	Loop detector	Ground key	B2EN = 1**
5	1 0 1	Standby	Loop detector	Ground key	V_{BAT1}
6*	1 1 0	Active Polarity Reversal	Loop detector	Ground key	B2EN
7*	1 1 1	OHT Polarity Reversal	Loop detector	Ground key	

Notes:

- * Only -1 and -2 performance grade devices support polarity reversal.
- ** For correct ground-start operation using Tip Open, V_{BAT1} on-hook battery must be used.

Table 2. User-Programmable Components

$Z_T = 500(Z_{2WIN} - 2R_F)$	Z_T is connected between the VTX and RSN pins. The fuse resistors are R_F , and Z_{2WIN} is the desired 2-wire AC input impedance. When computing Z_T , the internal current amplifier pole and any external stray capacitance between VTX and RSN must be taken into account.
$Z_{RX} = \frac{Z_L}{G_{42L}} \cdot \frac{1000 \cdot Z_T}{Z_T + 500(Z_L + 2R_F)}$	Z_{RX} is connected from V_{RX} to R_{SN} . Z_T is defined above, and G_{42L} is the desired receive gain.
$R_{DC1} + R_{DC2} = \frac{2500}{I_{LOOP}}$ $R_{DCR1} + R_{DCR2} = \frac{3000}{I_{ringlim}}$ $C_{DC} = 19 \text{ ms} \cdot \frac{R_{DC1} + R_{DC2}}{R_{DC1}R_{DC2}}$ $C_{DCR} = \frac{R_{DCR1} + R_{DCR2}}{R_{DCR1}R_{DCR2}} \cdot 150 \text{ } \mu\text{s}$	<p>R_{DC1}, R_{DC2}, and C_{DC} form the network connected to the RDC pin. I_{LOOP} is the desired loop current in the constant-current region.</p> <p>R_{DCR1}, R_{DCR2}, and C_{DCR} form the network connected to the RDCR pin. See Applications Circuit for these components.</p> <p>C_{DCR} sets the ringing time constant, which can be between 15 μs and 150 μs.</p>
$R_D = R_{LTH} \cdot 12.67$ for high battery state	R_D is the resistor connected from the RD pin to GND and R_{LTH} is the loop-resistance threshold between on-hook and off-hook detection. R_D should be greater than 56 k Ω to guarantee detection occurs in the Standby state. Choose the value of R_D for high battery state; then use the equation for R_{LTH} to find where the threshold is for low battery.
Loop-Threshold Detect Equations	
$R_{LTH} = \frac{R_D}{12.67}$ for high battery	This is the same equation as for R_D above, except solved for R_{LTH} .
$R_{LTH} = \frac{R_D}{11.37}$ for low battery	For low battery, the detect threshold is slightly higher, which avoids oscillating between states.
$R_{LTH} = \frac{ V_{BAT1} - 10}{915} \cdot R_D - 400 - 2R_F$	$R_{LTH \text{ standby}} < R_{LTH \text{ active}} < V_{BAT1} < R_{LTH \text{ active}} < V_{BAT2}$, which guarantees no unstable states under all operating conditions. This equation shows at what resistance the standby threshold is; it is actually a current threshold rather than a resistance threshold, which is shown by the Vbat dependency.

DC FEED CHARACTERISTICS

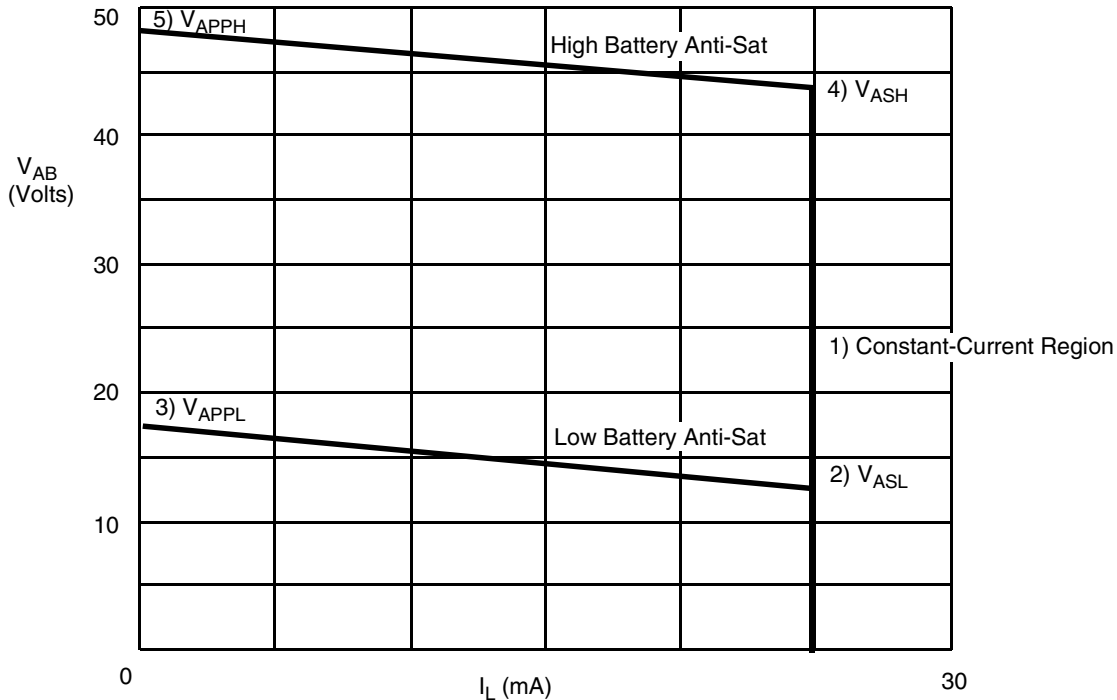

Figure 1. Typical V_{AB} vs. I_L DC Feed Characteristics

$$R_{DC} = R_{DC1} + R_{DC2} = 20 \text{ k}\Omega + 80 \text{ k}\Omega = 100 \text{ k}\Omega$$

$$(V_{BAT1} = -75 \text{ V}, V_{BAT2} = -24 \text{ V})$$

Notes:

1. Constant-current region: $V_{AB} = I_L R_L = \frac{2500}{RDC} R_L$; where $R_L = R_L + 2R_F$,

2. Low battery $V_{ASL} = \frac{1000 \cdot (104 \cdot 10^3 + R_{SGL})}{6720 \cdot 10^3 + (80 \cdot R_{SGL})}$; where R_{SGL} = resistor to GND, B2EN = logic Low.

Anti-sat region: $V_{ASL} = \frac{1000 \cdot (R_{SGL} - 56 \cdot 10^3)}{6720 \cdot 10^3 + (80 \cdot R_{SGL})}$; where R_{SGL} = resistor to V_{CC} , B2EN = logic Low. R_{SGL} to V_{CC} must be greater than 100 k Ω .

3. $V_{APPL} = 4.17 + V_{ASL}$
 $I_{LOOP} = \frac{V_{APPL}}{\frac{(R_{DC1} + R_{DC2})}{600} + 2R_F + R_{LOOP}}$

4. High battery $V_{ASH} = V_{ASHH} + V_{ASL}$
 Anti-sat region: $V_{ASHH} = \frac{1000 \cdot (70 \cdot 10^3 + R_{SGH})}{1934 \cdot 10^3 + (31.75 \cdot R_{SGH})}$; where R_{SGH} = resistor to GND, B2EN = logic High.

$$V_{ASHH} = \frac{1000 \cdot (R_{SGH} + 2.75 \cdot 10^3)}{1934 \cdot 10^3 + (31.75 \cdot R_{SGH})}$$
; where R_{SGH} = resistor to V_{CC} , B2EN = logic High. R_{SGH} to V_{CC} must be greater than 100 k Ω .

5. $V_{APPH} = 4.17 + V_{ASH}$
 $I_{LOOPH} = \frac{V_{APPH}}{\frac{(R_{DC1} + R_{DC2})}{600} + 2R_F + R_{LOOP}}$

RING-TRIP COMPONENTS

$$R_{RT2} = 12 \text{ k}\Omega$$

$$C_{RT} = 1.5 \text{ }\mu\text{F}$$

$$R_{RT1} = 320 \cdot CF \cdot \frac{V_{BAT1}}{V_{bat} - 5 - (24 \text{ }\mu\text{A} \cdot 320 \cdot CF \cdot (R_{LRT} + 150 + 2R_F))} \cdot (R_{LRT} + 150 + 2R_F)$$

where R_{LRT} = Loop-detection threshold resistance for ring trip and CF = Crest factor of ringing signal (≈ 1.25)

R_{SLEW} , C_{SLEW}

Ring waveform rise time $\approx 0.214 \cdot (R_{SLEW} \cdot C_{SLEW}) \approx tr$.

For a 1.25 crest factor @ 20 Hz, $tr \approx 10 \text{ mS}$.

$\therefore (R_{SLEW} = 150 \text{ k}\Omega, C_{SLEW} = 0.33 \text{ }\mu\text{F})$

C_{SLEW} should be changed if a different crest factor is desired.

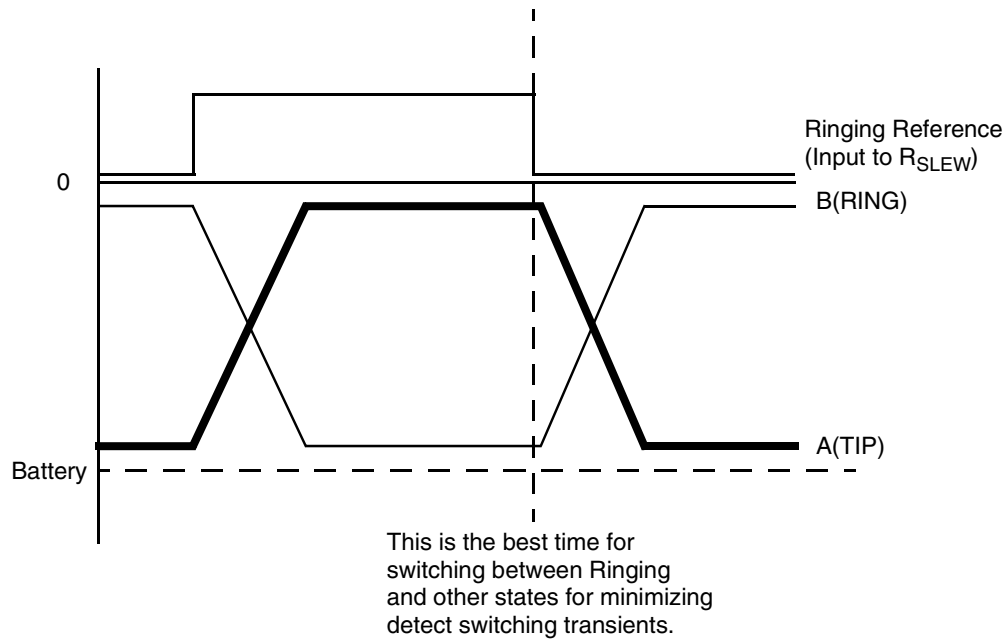
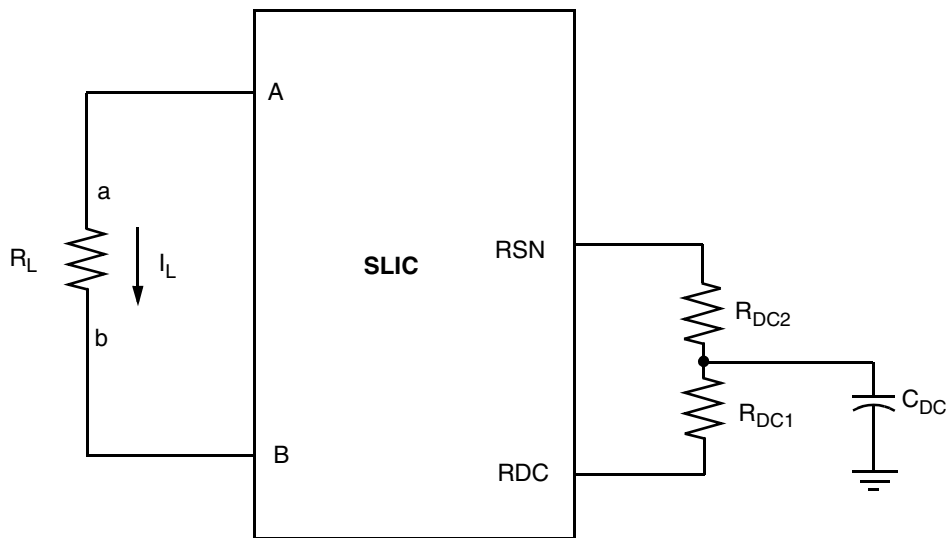

Figure 2. Ringing Waveforms



Feed current programmed by R_{DC1} and R_{DC2}

Figure 3. Feed Programming

TEST CIRCUITS

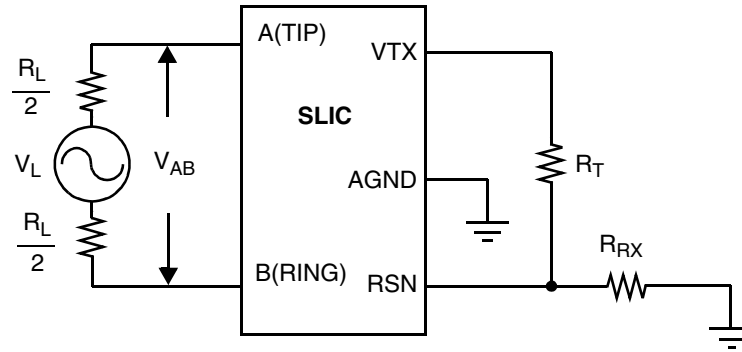

$$I_{L2-4} = 20 \log (V_{TX} / V_{AB})$$

A. Two- to Four-Wire Insertion Loss

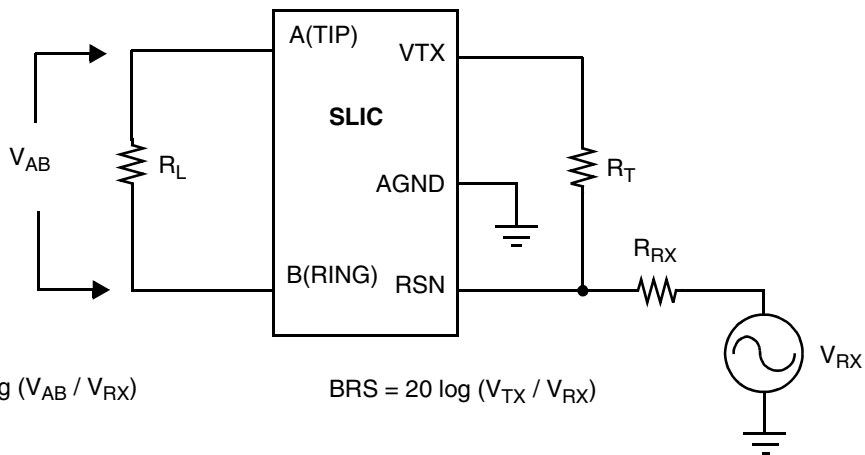

$$I_{L4-2} = 20 \log (V_{AB} / V_{RX})$$

$$BRS = 20 \log (V_{TX} / V_{RX})$$

B. Four- to Two-Wire Insertion Loss and Four- to Four-Wire Balance Return Signal

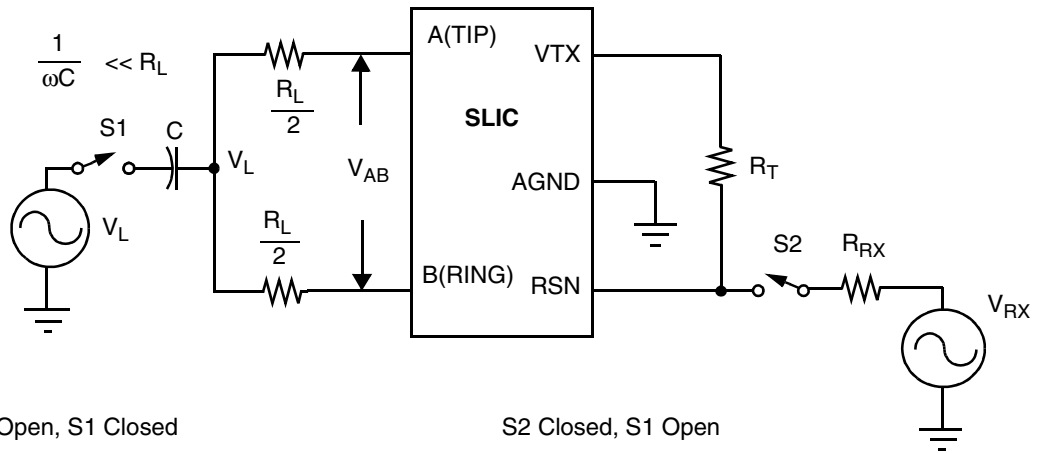

S2 Open, S1 Closed

$$L-T \text{ Long. Bal.} = -20 \log (V_{AB} / V_L)$$

$$L-4 \text{ Long. Bal.} = -20 \log (V_{TX} / V_L)$$

S2 Closed, S1 Open

$$4-L \text{ Long. Sig. Gen.} = 20 \log (V_L / V_{RX})$$

C. Longitudinal Balance

TEST CIRCUITS (continued)

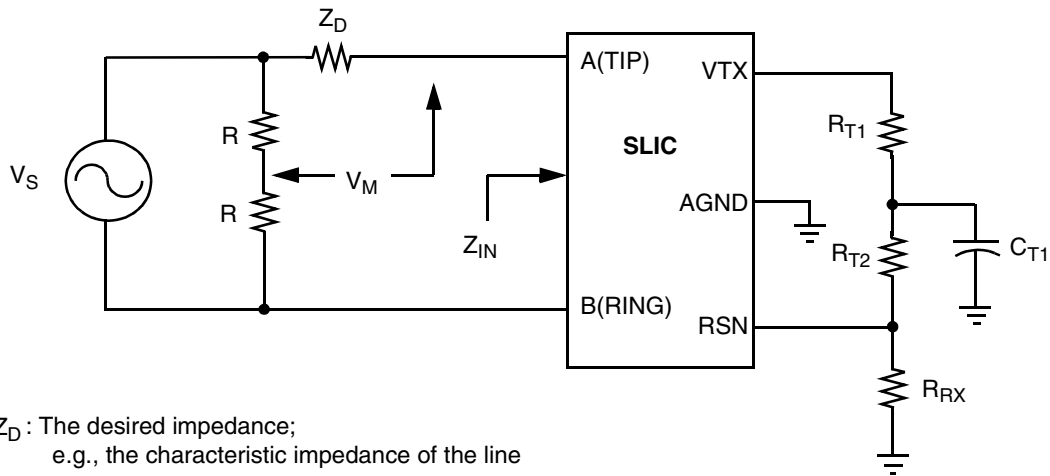

Z_D : The desired impedance;
e.g., the characteristic impedance of the line

$$\text{Return loss} = -20 \log (2 V_M / V_S)$$

D. Two-Wire Return Loss Test Circuit

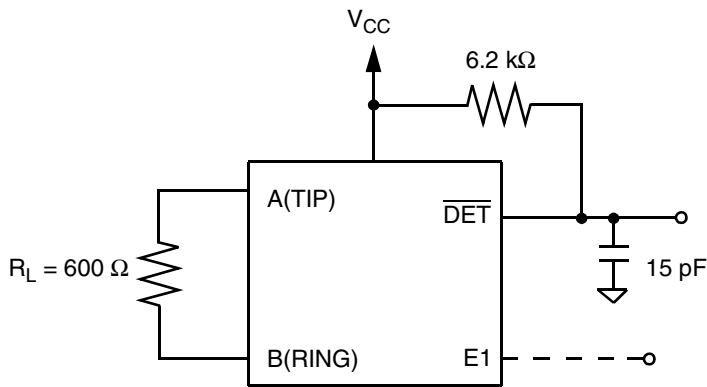

E. Loop-Detector Switching

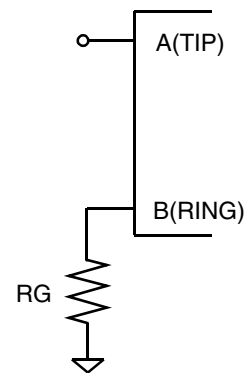

F. Ground-Key Switching

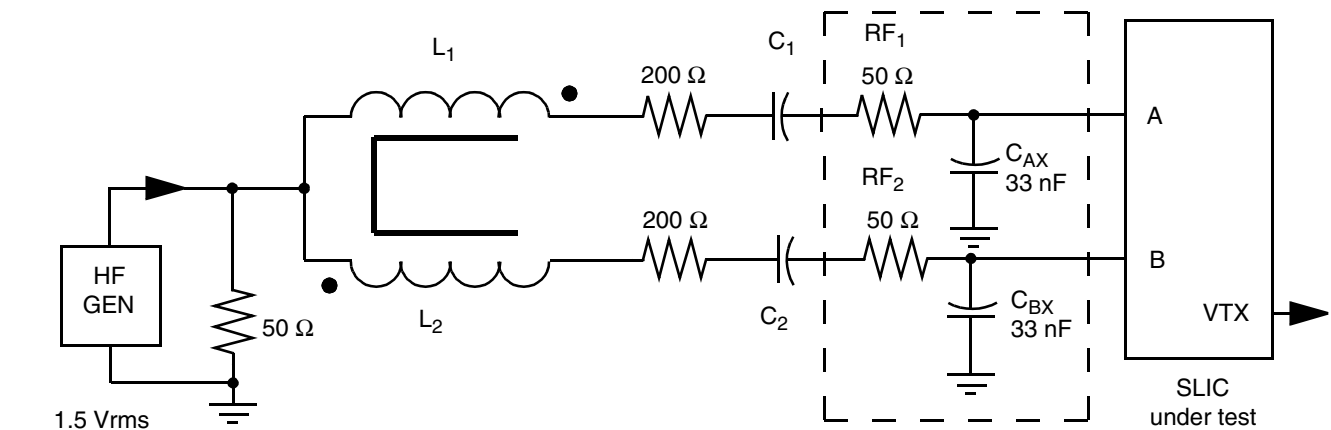

G. RFI Test Circuit

TEST CIRCUITS (continued)

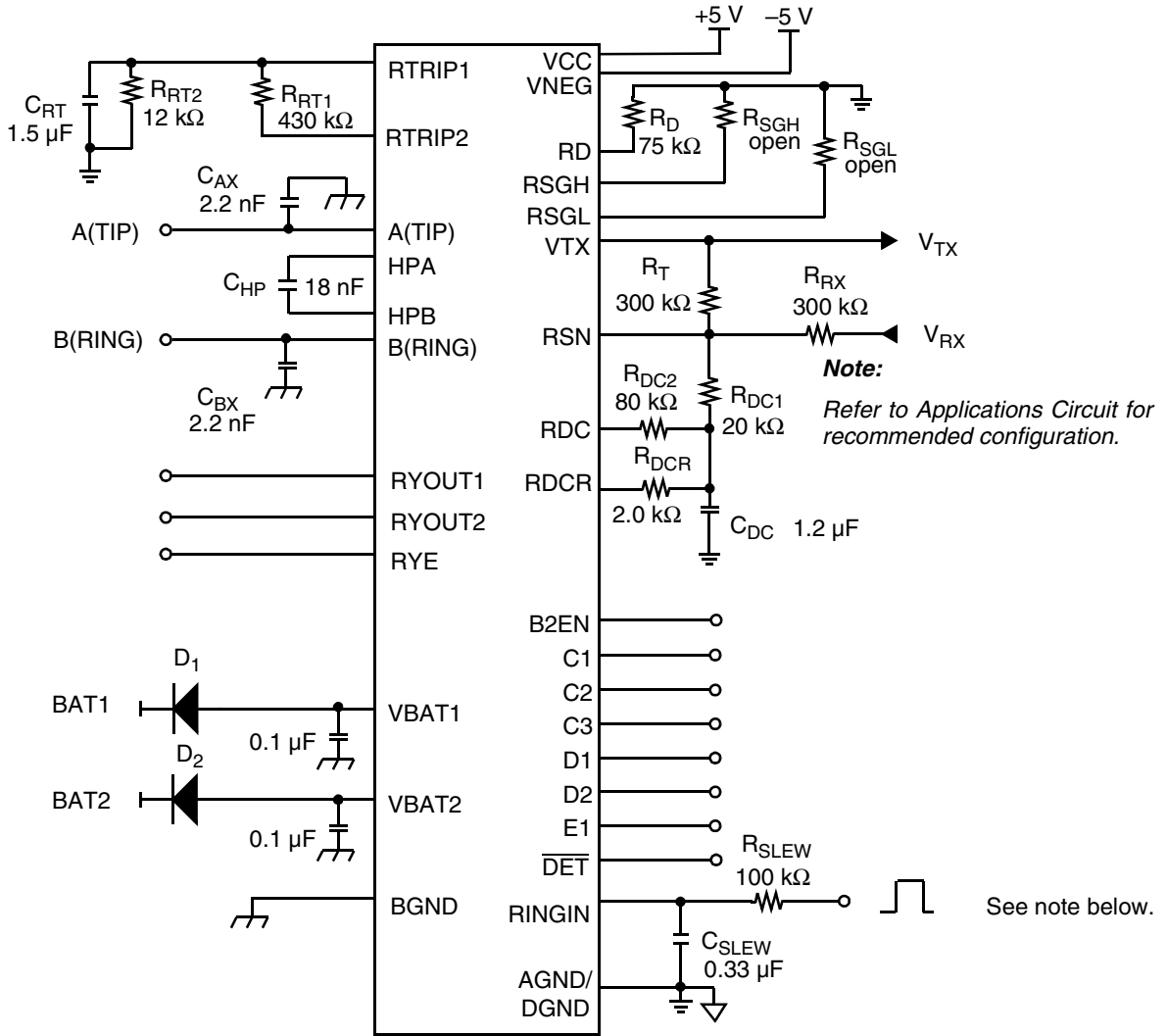

Note:

The input should be 50% duty cycle CMOS-compatible input.

BATTERY GROUND



ANALOG GROUND



DIGITAL GROUND



H. Am79R79 Test Circuit

APPLICATION CIRCUIT

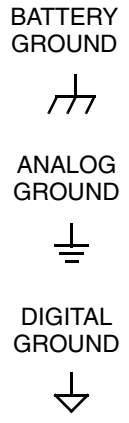
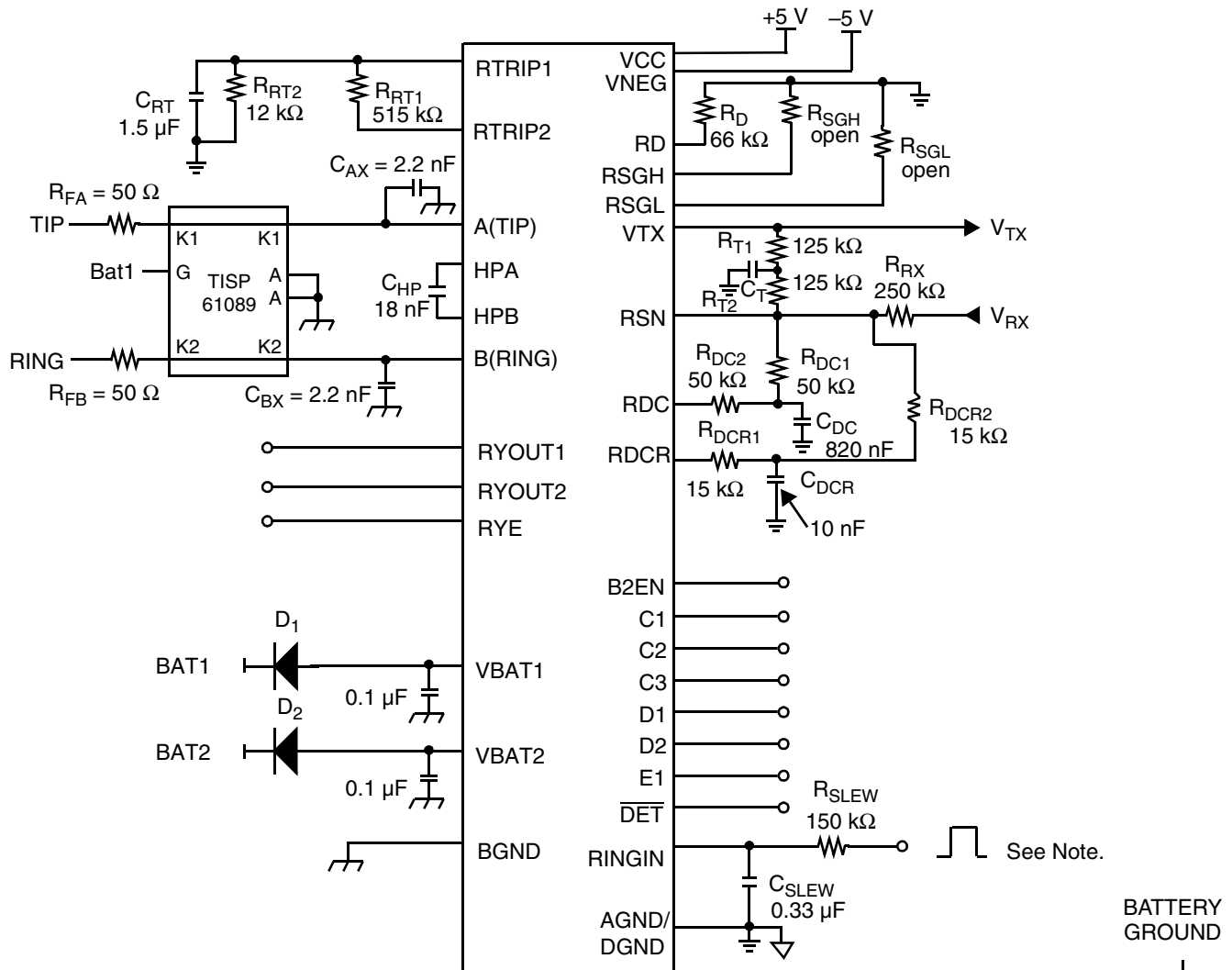

Assumptions:

- | | | |
|---------------------------------|--|-----------------------------|
| 1. 1.25 CF | 4. 5.2 kΩ High Battery Loop Threshold | 7. $G_{42L} = 1$ |
| 2. 25 mA I_{LOOP} | 5. 925 Ω Ringing Loop Threshold | 8. -70 V Vbat1, -24 V Vbat2 |
| 3. 100 mA Ringing Current Limit | 6. 600 Ω Two-wire Impedance, 600 Ω Z_L | |

Note:

The input should be 50% duty cycle CMOS-compatible input.

I. Application Circuit

PHYSICAL DIMENSION

PL032

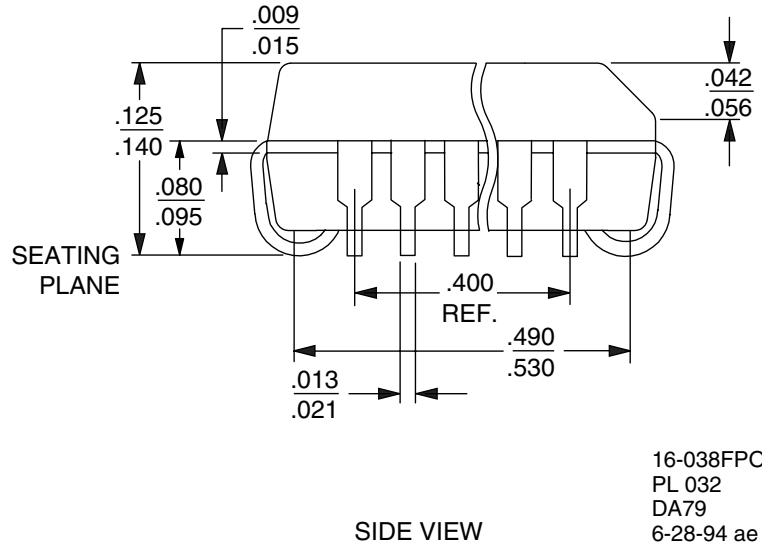
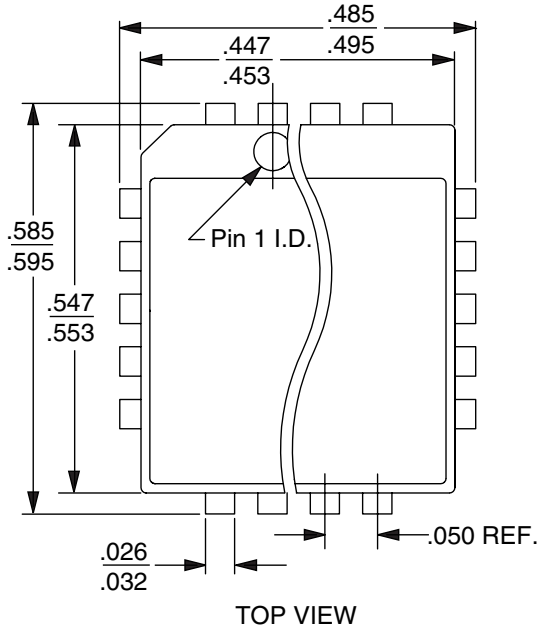

16-038FPO-5
 PL 032
 DA79
 6-28-94 ae

REVISION SUMMARY

Revision B to Revision C

- Minor changes were made to the data sheet style and format to conform to AMD standards.
- Electrical Characteristics; Last row under Ring Signal, min changed from 130 to 150, typ changed from 160 to 180, and max changed from 190 to 210.
- SLIC Decoding Table; Added B2EN reference to the Battery Selection column and its corresponding note to the notes section.
- Applications Circuit; Revised

Revision C to Revision D

- Minor changes were made to the data sheet style and format to conform to AMD standards.

Revision D to Revision E

- On pages 17 and 18, R_{DC1} and R_{DC2} were switched.

Revision E to Revision F

- The physical dimension (PL032) was added to the Physical Dimension section.
- Deleted the Ceramic DIP and Plastic DIP packages and references to them.
- Updated the Pin Description table to correct inconsistencies.

Revision F to Revision G

- The equation on page 13 was changed:

from:
$$R_{RT1} = 300 \cdot CF \cdot \frac{V_{BAT1}}{V_{bat} - 3.5 - (15 \mu A \cdot 300 \cdot CF \cdot (R_{LRT} + 150 + 2R_F))} \cdot (R_{LRT} + 150 + 2R_F)$$

to:
$$R_{RT1} = 320 \cdot CF \cdot \frac{V_{BAT1}}{V_{bat} - 5 - (24 \mu A \cdot 320 \cdot CF \cdot (R_{LRT} + 150 + 2R_F))} \cdot (R_{LRT} + 150 + 2R_F)$$

The contents of this document are provided in connection with Advanced Micro Devices, Inc. ("AMD") products. AMD makes no representations or warranties with respect to the accuracy or completeness of the contents of this publication and reserves the right to make changes to specifications and product descriptions at any time without notice. No license, whether express, implied, arising by estoppel or otherwise, to any intellectual property rights is granted by this publication. Except as set forth in AMD's Standard Terms and Conditions of Sale, AMD assumes no liability whatsoever, and disclaims any express or implied warranty, relating to its products including, but not limited to, the implied warranty of merchantability,

fitness for a particular purpose, or infringement of any intellectual property right.

AMD's products are not designed, intended, authorized or warranted for use as components in systems intended for surgical implant into the body, or in other applications intended to support or sustain life, or in any other application in which the failure of AMD's product could create a situation where personal injury, death, or severe property or environmental damage may occur. AMD reserves the right to discontinue or make changes to its products at any time without notice.

© 1999 Advanced Micro Devices, Inc.
All rights reserved.

Trademarks

AMD, the AMD logo, and combinations thereof, and DSLAC and QSLAC are trademarks of Advanced Micro Devices, Inc.

Other product names used in this publication are for identification purposes only and may be trademarks of their respective companies.