

### 4096 BIT BIPOLAR TTL

#### PROGRAMMABLE READ ONLY MEMORY

#### Description

The μPB406C, μPB406D, μPB426C and μPB426D are high speed electrically programmable fully decoded 4096 bit TTL read only memories. On-chip address decoding, two chip select inputs and open-collector / three-state outputs allow easy expansion of memory capacity. The μPB406C, μPB406D, μPB426C and μPB426D are fabricated with logic level zero (low); logic level one (high) can be electrically programmed into the selected bit locations. The same address inputs are used for both programming and reading.

#### Features

- 1024 WORDS x 4 BITS Organization (Fully Decoded)
- TTL Interface
- Fast Read Access Time : 35 ns MAX. (μPB406-3, μPB426-3)
- Medium Power Consumption : 500 mW TYP.
- Two Chip Select Inputs for Memory Expansion
- Open-Collector Output (μPB406C, μPB406D) / Three-State Outputs (μPB426C, μPB426D)
- Cerdip 18-Lead Dual In-Line Package (μPB406D, μPB426D)
- Plastic 18-Lead Dual In-Line Package (μPB406C, μPB426C)
- Fast Programming Time : 200 μs/bit TYP.
- Compatibility with : Signetics' 82S136 / 137, Harris' HPROM HM-7642 / 7643 and Equivalent Devices (as a ROM)

#### Connection Diagram (Top View)

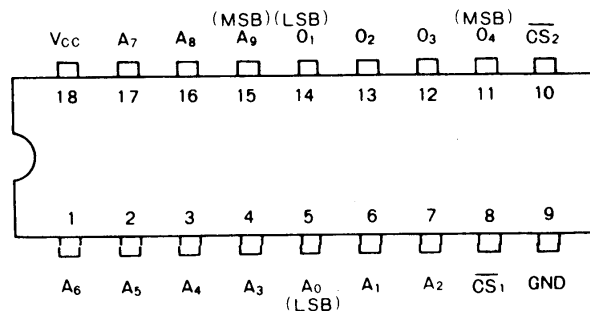

#### Pin names

- A0-A9 : Address Inputs
- O1-O4 : Data Outputs
- CS1, CS2 : Chip Select Inputs
- VCC : Power Supply (+5V)
- GND : Ground

Operation

1. Programming

A logic one can be permanently programmed into a selected bit location by using special equipment (programmer). First, the desired word is selected by the ten address inputs in TTL levels. Either or both of the two chip select inputs should be at a logic one (high). Secondly, a train of high current programming pulses is applied to the desired output. After the sensed voltage indicates that the selected bit is in the logic one state, an additional pulse train is applied, then is stopped.

2. Reading

To read the memory, both of the two chip select inputs should be held at logic zero (low). The outputs then correspond to the data programmed in the selected words. When either or both of the two chip select inputs are at logic one (high), all the outputs will be high (floating).

Logic Diagram

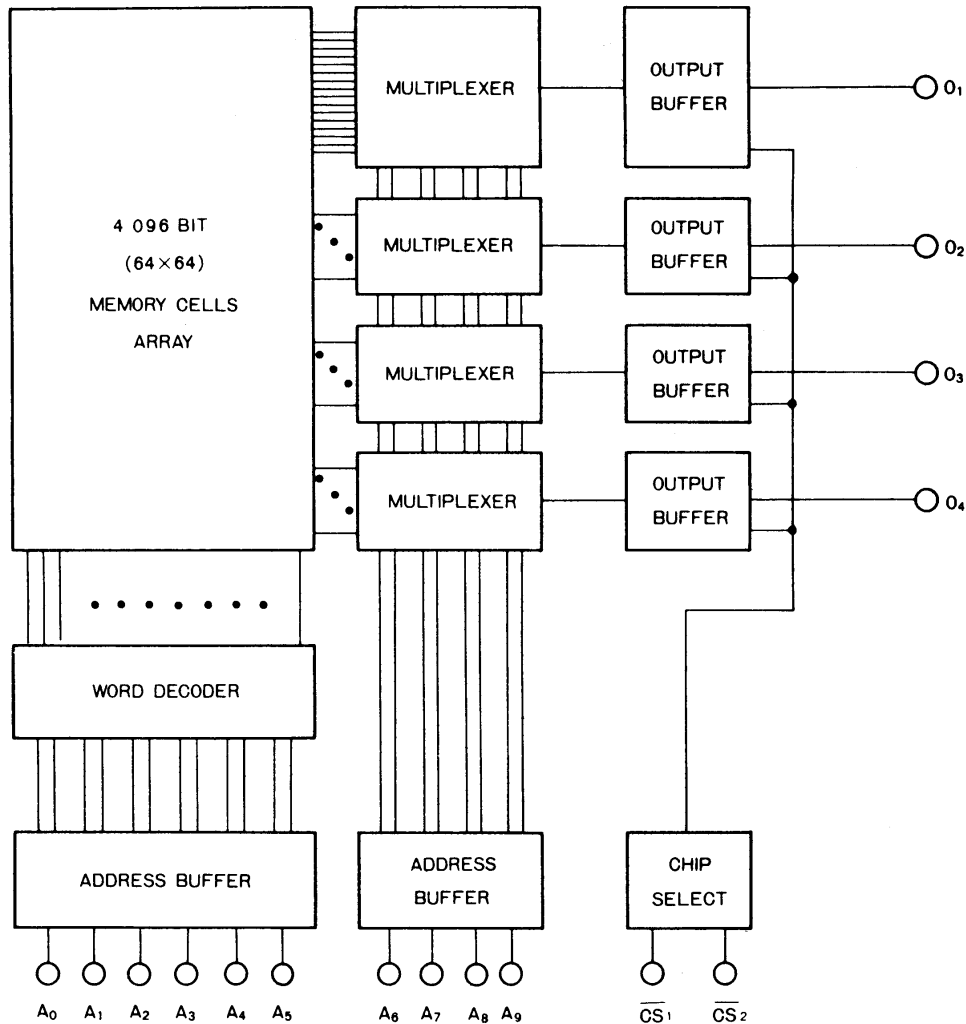

### ABSOLUTE MAXIMUM RATINGS

Supply Voltage	$V_{CC}$	-0.5 to +7.0	V
Input Voltage	$V_I$	-0.5 to +5.5	V
Output Voltage	$V_O$	-0.5 to +5.5	V
Output Current	$I_O$	50	mA
Operating Temperature	$T_{opt}$	-25 to +75	°C
Storage Temperature (Cerdip Package)	$T_{stg}$	-65 to +150	°C
Storage Temperature (Plastic Package)	$T_{stg}$	-55 to +125	°C

### D.C. CHARACTERISTICS ( $V_{CC}=4.5$ to $5.5$ V, $T_a=0$ to $75$ °C)

CHARACTERISTIC	SYMBOL	MIN.	TYP.	MAX.	UNIT	TEST CONDITIONS
Input High Voltage	$V_{IH}$	2.0			V	
Input Low Voltage	$V_{IL}$			0.8	V	
Input High Current	$I_{IH}$			40	μA	$V_I=5.5$ V $V_{CC}=5.5$ V
Input Low Current	$-I_{IL}$			0.5	mA	$V_I=0.4$ V $V_{CC}=5.5$ V
Output Low Voltage	$V_{OL}$			0.45	V	$I_O=16$ mA $V_{CC}=5.5$ V
Output Leakage Current	$I_{OFF1}$			40	μA	$V_O=5.5$ V $V_{CC}=5.5$ V
Output Leakage Current	$-I_{OFF2}$			40	μA	$V_O=0.4$ V $V_{CC}=5.5$ V
Input Clamp Voltage	$-V_{IC}$			1.2	V	$I_I=-18$ mA $V_{CC}=4.5$ V
Power Supply Current	$I_{CC}$		100	150	mA	All Inputs Grounded. $V_{CC}=5.5$ V
* Output High Voltage	$V_{OH}$	2.4			V	$I_O=-2.4$ mA $V_{CC}=4.5$ V
* Output Short Circuit Current	$-I_{SC}$	15		60	mA	$V_O=0$ V

\* Note : Applicable to μPB426C and μPB426D.

### CAPACITANCE ( $V_{CC}=5$ V, $f=1$ MHz, $T_a=25$ °C)

CHARACTERISTIC	SYMBOL	MIN.	MAX.	UNIT	TEST CONDITIONS
Input Capacitance	$C_{IN}$		8	pF	$V_{IN}=2.5$ V
Output Capacitance	$C_{OUT}$		10	pF	$V_{OUT}=2.5$ V

### A.C. CHARACTERISTICS ( $V_{CC}=4.5$ to $5.5$ V, $T_a=0$ to $75$ °C)

CHARACTERISTIC	SYMBOL	μPB406C-3, μPB406D-3 μPB426C-3, μPB426D-3		μPB406C-2, μPB406D-2 μPB426C-2, μPB426D-2		μPB406C-1, μPB406D-1 μPB426C-1, μPB426D-1		μPB406C, μPB406D μPB426C, μPB426D		UNIT
		MIN.	MAX.	MIN.	MAX.	MIN.	MAX.	MIN.	MAX.	
Address Access Time	$t_{AA}$	35		50		60		70		ns
Chip Select Access Time	$t_{ACS}$	25		30		40		45		ns
Chip Select Disable Time	$t_{DCS}$	25		30		40		45		ns

Note 1. Output Load: See Fig. 1.

Note 2. Input Waveform: 0.0 V for low level and 3.0 V for high level, less than 10 ns for both rise and fall times.

Note 3. Measurement References: 1.5 V for both inputs and outputs.

Note 4.  $C_L$  in Fig. 1 includes μg and probe stray capacitances.

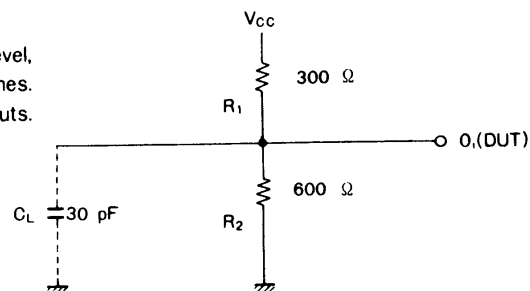

Fig. 1

**Programming Specification**

It is imperative that this specification be rigorously observed in order to correctly program the μPB406C, μPB406D, μPB426C and μPB426D. NEC will not accept responsibility for any device found to be defective if it were not programmed according to this specification.

CHARACTERISTIC	LIMIT	UNIT	NOTES
Ambient Temperature	25 ± 5	°C	
Programming Pulse			
Amplitude	200 ± 5 %	mA	
Clamp Voltage	28 +0 % -2 %	V	
Ramp Rate (Both in Rise and in Fall)	70 MAX.	V / μS	
Pulse Width	7.5 ± 5 %	μS	15 V point / 150 Ω load.
Duty Cycle	70 % MIN.		
Sense Current			
Amplitude	20 ± 0.5	mA	
Clamp Voltage	28 +0 % -2 %	V	
Ramp Rate	70 MAX.	V / μS	15 V point / 150 Ω load.
Sense Current Interruption before and after address change	10 MIN.	μS	
Programming Vcc	5.0 +5 % -0 %	V	
Maximum Sensed Voltage * for programmed "1"	7.0 ± 0.1	V	
Delay from trailing edge of programming pulse before sensing output voltage	0.7 MIN.	μS	

\* A bit is judged to be programmed when two successive sense readings 10 μs apart with no intervening programming pulse, pass the limit. When this condition has been met, four additional pulses are applied and the pulse train, then the sense current is terminated.

Fig. 2 Typical Output Voltage Waveform.

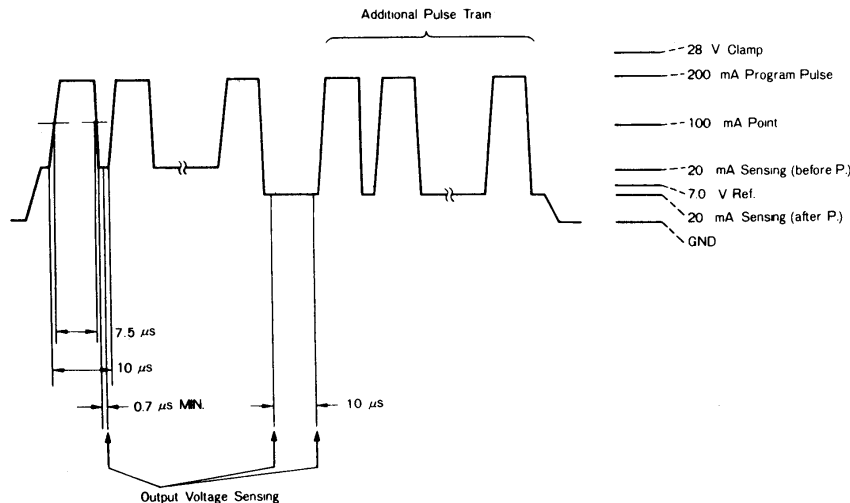

## Package Dimensions

### 18PIN Plastic DIP

Item	Millimeters
A	22.86 max
B	1.27 max
C	2.54 [TP]
D	.50 ± .10
E	20.32
F	1.2 min
G	3.5 ± .3
H	.51 min
I	4.31 max
J	5.08 max
K	7.62 [TP]
L	6.4
M	.25 <sup>+ .10</sup> <sub>-.05</sub>
N	1.0 min

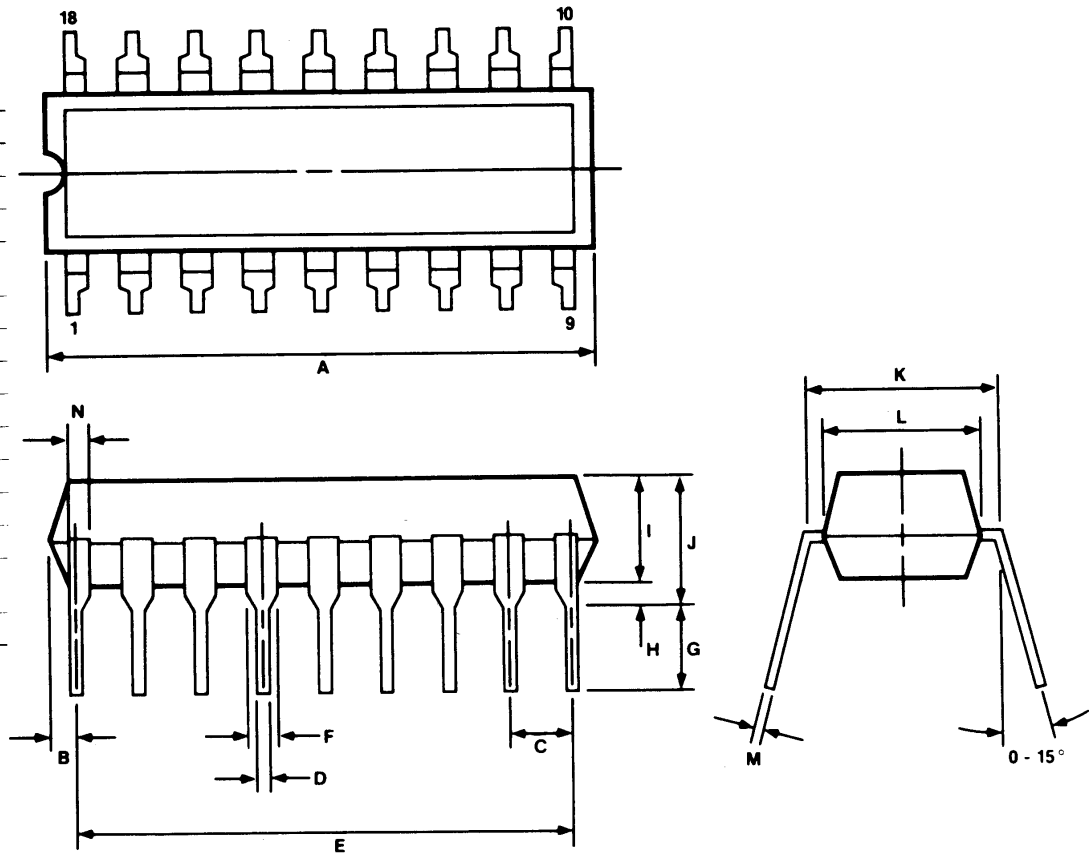

### 18PIN Cerdip

Item	Millimeters
A	22.86 max
B	1.27 max
C	2.54 [TP]
D	.46 ± .05
E	20.32
F	1.42 min
G	3.5 ± .3
H	.51 min
I	3.95
J	5.08 max
K	7.62 [TP]
L	6.60
M	.25 ± .05
N	.89 min

